

JVC

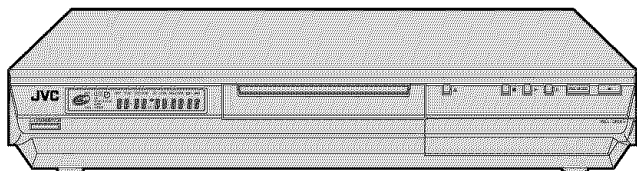

DVD VIDEO RECORDER

DR-M10

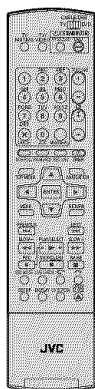

INSTRUCTIONS

For Customer Use:

Enter below the Model No. and Serial No. which are located on the rear of cabinet. Retain this information for future reference.

Model No. _____

Serial No. _____

Dear Customer,

Thank you for purchasing the JVC DVD video recorder. Before use, please read the safety information and precautions to ensure safe use of your new unit.

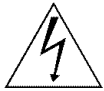
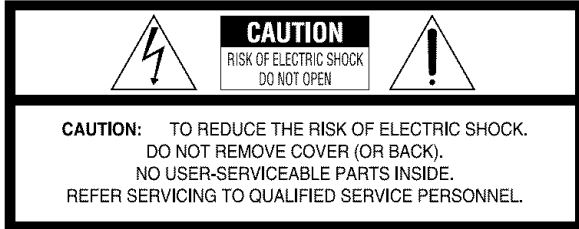
CAUTIONS

The lightning flash with arrowhead symbol, within an equilateral triangle, is intended to alert the user to the presence of uninsulated "dangerous voltage" within the product's enclosure that may be of sufficient magnitude to constitute a risk of electric shock to persons.



The exclamation point within an equilateral triangle is intended to alert the user to the presence of important operating and maintenance (servicing) instructions in the literature accompanying the appliance.

WARNING:

TO PREVENT FIRE OR SHOCK HAZARD, DO NOT EXPOSE THIS UNIT TO RAIN OR MOISTURE.

CAUTION:

This unit should be used with AC 120V~, 60Hz only. To prevent electric shocks and fire hazards, DO NOT use any other power source.

CAUTION:

TO PREVENT ELECTRIC SHOCK, MATCH WIDE BLADE OF PLUG TO WIDE SLOT, FULLY INSERT.

ATTENTION:

POUR ÉVITER LES CHOCS ÉLECTRIQUES, INTRODUIRE LA LAME LA PLUS LARGE DE LA FICHE DANS LA BORNE CORRESPONDANTE DE LA PRISE ET POUSSER JUSQU'AU FOND.

Note to CATV system installer:

This reminder is provided to call the CATV system installer's attention to Article 820-40 of the NEC that provides guidelines for proper grounding and, in particular, specifies that the cable ground shall be connected to the grounding system of the building, as close to the point of cable entry as practical.

CAUTION:

Changes or modifications not approved by JVC could void user's authority to operate the equipment.

CAUTION

A UNIT IS A CLASS 1 LASER PRODUCT. HOWEVER THIS UNIT USES A VISIBLE LASER BEAM WHICH COULD CAUSE HAZARDOUS RADIATION EXPOSURE IF DIRECTED. BE SURE TO OPERATE THE UNIT CORRECTLY AS INSTRUCTED.

WHEN THIS UNIT IS PLUGGED INTO THE WALL OUTLET, DO NOT PLACE YOUR EYES CLOSE TO THE OPENING OF THE DISC TRAY AND OTHER OPENINGS TO LOOK INTO THE INSIDE OF THIS UNIT.

USE OF CONTROLS OR ADJUSTMENTS OR PERFORMANCE OF PROCEDURES OTHER THAN THOSE SPECIFIED HEREIN MAY RESULT IN HAZARDOUS RADIATION EXPOSURE.

DO NOT OPEN COVERS AND DO NOT REPAIR YOURSELF. REFER SERVICING TO QUALIFIED PERSONNEL.

CLASS 1 LASER PRODUCT**REPRODUCTION OF LABELS****WARNING LABEL INSIDE OF THE UNIT**

CAUTION	VISIBLE AND INVISIBLE LASER RADIATION WHEN OPEN. AVOID EXPOSURE TO BEAM. DO NOT STARE INTO BEAM OR VIEW DIRECTLY WITH OPTICAL INSTRUMENTS.
ADVARSEL	SYNLIG OG USYNLIG LASERSTRÅLING VED ÅBNING. UNDGÅ UDSÆTTELSE FOR STRÅLING SE IKKE IND I STRÅLEN - HELLER IKKE MED OPTISKE INSTRUMENTER.
ADVARSEL	SYNLIG OG USYNLIG LASERSTRÅLING NÅR DEKSEL ÅPNES. UNDGÅ EKSPONERING FOR STRÅLEN STIRR IKKE INN I STRÅLEN ELLER SE DIREKTE MED OPTISKE INSTRUMENTER.
VARO!	AVATTAESSA OLET ALTTIINA NÄKYVÄÄ JA NÄKYMÄTÖN LASERSÄTEILYLLE. ÄLÄ TUJOTA SÄTEESEEN ÄLÄKÄ KATSO SITÄ OPTISEN LAITTEEN LÄPI.
WARNING	SYNLIG OCH OSYNLIG LASERSTRÅLNING NÅR DENNA DEL ÄR ÖPPNAD. STRÅLEN ÄR FARLIG STIRRA EJ IN I STRÅLEN OCH BETRAKTA EJ STRÅLEN MED OPTISKA INSTRUMENT.

OR

CAUTION: Visible and invisible laser radiation when open and interlock failed or defeated. AVOID DIRECT EXPOSURE TO BEAM.	ADVARSEL: Synlig og usynlig laserstråling når maskinen er åben eller interlocken fejler. Undgå direkte eksponering til stråling.	VARNING : Synlig och osynlig laserstråling när den öppnas och spärren är urkopplad. Betrakta ej strålen.	VARO: Avattaessa ja suojalukitus ohitettuna tai viallisena olet alttiina näkyvälle ja näkymättömälle lasersäteilylle. Vältä säteeseen suoraan iäseesi. (!)
--	---	---	---

IMPORTANT PRODUCT SAFETY INSTRUCTIONS

Electrical energy can perform many useful functions. But improper use can result in potential electrical shock or fire hazards. This product has been engineered and manufactured to assure your personal safety. In order not to defeat the built-in safeguards, observe the following basic rules for its installation, use and servicing.

ATTENTION

Follow and obey all warnings and instructions marked on your product and its operating instructions. For your safety, please read all the safety and operating instructions before you operate this product and keep this booklet for future reference.

INSTALLATION

1. Grounding or Polarization

(A) Your product may be equipped with a polarized alternating-current line plug (a plug having one blade wider than the other). This plug will fit into the power outlet only one way. This is a safety feature.

If you are unable to insert the plug fully into the outlet, try reversing the plug. If the plug should still fail to fit, contact your electrician to replace your obsolete outlet. Do not defeat the safety purpose of the polarized plug.

(B) Your product may be equipped with a 3-wire grounding-type plug, a plug having a third (grounding) pin. This plug will only fit into a grounding-type power outlet. This is a safety feature.

If you are unable to insert the plug into the outlet, contact your electrician to replace your obsolete outlet. Do not defeat the safety purpose of the grounding-type plug.

2. Power Sources

Operate your product only from the type of power source indicated on the marking label. If you are not sure of the type of power supply to your home, consult your product dealer or local power company. If your product is intended to operate from battery power, or other sources, refer to the operating instructions.

3. Overloading

Do not overload wall outlets, extension cords, or integral convenience receptacles as this can result in a risk of fire or electric shock.

4. Power Cord Protection

Power supply cords should be routed so that they are not likely to be walked on or pinched by items placed upon or against them, paying particular attention to cords at plugs, convenience receptacles, and the point where they exit from the product.

5. Ventilation

Slots and openings in the cabinet are provided for ventilation. To ensure reliable operation of the product and to protect it from overheating, these openings must not be blocked or covered.

- Do not block the openings by placing the product on a bed, sofa, rug or other similar surface.
- Do not place the product in a built-in installation such as a bookcase or rack unless proper ventilation is provided or the manufacturer's instructions have been adhered to.

6. Wall or Ceiling Mounting

The product should be mounted to a wall or ceiling only as recommended by the manufacturer.

ANTENNA INSTALLATION INSTRUCTIONS

1. Outdoor Antenna Grounding

If an outside antenna or cable system is connected to the product, be sure the antenna or cable system is grounded so as to provide some protection against voltage surges and built-up static charges. Article 810 of the National Electrical Code, ANSI/NFPA 70, provides information with regard to proper grounding of the mast and supporting structure, grounding of the lead-in wire to an antenna discharge unit, size of grounding connectors, location of antenna discharge unit, connection to grounding electrodes, and requirements for the grounding electrode.

2. Lightning

For added protection for this product during a lightning storm, or when it is left unattended and unused for long periods of time, unplug it from the wall outlet and disconnect the antenna or cable system. This will prevent damage to the product due to lightning and power-line surges.

3. Power Lines

An outside antenna system should not be located in the vicinity of overhead power lines or other electric light or power circuits, or where it can fall into such power lines or circuits. When installing an outside antenna system, extreme care should be taken to keep from touching such power lines or circuits as contact with them might be fatal.

EXAMPLE OF ANTENNA GROUNDING AS PER NATIONAL ELECTRICAL CODE, ANSI/NFPA 70

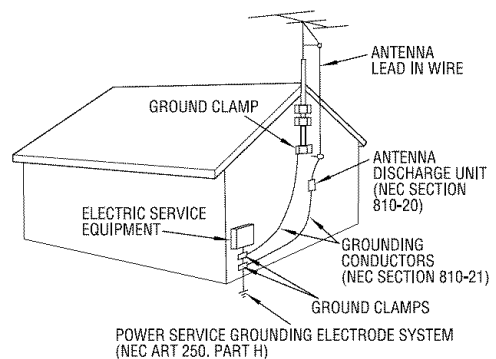

NEC – NATIONAL ELECTRICAL CODE

USE

1. Accessories

To avoid personal injury:

- Do not place this product on an unstable cart, stand, tripod, bracket, or table. It may fall, causing serious injury to a child or adult, and serious damage to the product.
- Use only with a cart, stand, tripod, bracket, or table recommended by the manufacturer or sold with the product.
- Use a mounting accessory recommended by the manufacturer and follow the manufacturer's instructions for any mounting of the product.
- Do not try to roll a cart with small casters across thresholds or deep-pile carpets.

2. Product and Cart Combination

A product and cart combination should be moved with care. Quick stops, excessive force, and uneven surfaces may cause the product and cart combination to overturn.

PORTABLE CART WARNING
(Symbol provided by RETAC)



3. Water and Moisture

Do not use this product near water—for example, near a bath tub, wash bowl, kitchen sink or laundry tub, in a wet basement, or near a swimming pool and the like.

4. Object and Liquid Entry

Never push objects of any kind into this product through openings as they may touch dangerous voltage points or short-out parts that could result in a fire or electric shock. Never spill liquid of any kind on the product.

5. Attachments

Do not use attachments not recommended by the manufacturer of this product as they may cause hazards.

6. Cleaning

Unplug this product from the wall outlet before cleaning. Do not use liquid cleaners or aerosol cleaners. Use a damp cloth for cleaning.

7. Heat

The product should be situated away from heat sources such as radiators, heat registers, stoves, or other products (including amplifiers) that produce heat.

SERVICING

1. Servicing

If your product is not operating correctly or exhibits a marked change in performance and you are unable to restore normal operation by following the detailed procedure in its operating instructions, do not attempt to service it yourself as opening or removing covers may expose you to dangerous voltage or other hazards. Refer all servicing to qualified service personnel.

2. Damage Requiring Service

Unplug this product from the wall outlet and refer servicing to qualified service personnel under the following conditions:

- When the power supply cord or plug is damaged.
- If liquid has been spilled, or objects have fallen into the product.
- If the product has been exposed to rain or water.
- If the product does not operate normally by following the operating instructions. Adjust only those controls that are covered by the operating instructions as an improper adjustment of other controls may result in damage and will often require extensive work by a qualified technician to restore the product to its normal operation.
- If the product has been dropped or damaged in any way.
- When the product exhibits a distinct change in performance—this indicates a need for service.

3. Replacement Parts

When replacement parts are required, be sure the service technician has used replacement parts specified by the manufacturer or which have the same characteristics as the original part. Unauthorized substitutions may result in fire, electric shock or other hazards.

4. Safety Check

Upon completion of any service or repairs to this product, ask the service technician to perform safety checks to determine that the product is in safe operating condition.

HOW TO USE THIS INSTRUCTION MANUAL

- All major sections and subsections are listed in the Table Of Contents on page 6. Use this when searching for information on a specific procedure or feature.
- The Index on pages 12 – 17 lists frequently-used terms, and the number of the page on which they are used or explained in the manual. This section also illustrates the controls and connections on the front and rear panel, the front display panel and the remote control.
- The  mark signals a reference to another page for instructions or related information.
- Operation buttons necessary for the various procedures are clearly indicated through the use of illustrations at the beginning of each major section.

BEFORE YOU INSTALL YOUR NEW UNIT . . .

. . . please read the sections/literature listed below.

- "CAUTIONS" on page 2
- "IMPORTANT PRODUCT SAFETY INSTRUCTIONS" on pages 3 – 4

This equipment has been tested and found to comply with the limits for a Class B digital device, pursuant to Part 15 of the FCC Rules. These limits are designed to provide reasonable protection against harmful interference in a residential installation. This equipment generates, uses, and can radiate radio frequency energy and, if not installed and used in accordance with the instructions, may cause harmful interference to radio communications. However, there is no guarantee that interference will not occur in a particular installation. If this equipment does cause harmful interference to radio or television reception, which can be determined by turning the equipment off and on, the user is encouraged to try to correct the interference by one or more of the following measures:

- Reorient or relocate the receiving antenna.
- Increase the separation between the equipment and receiver.
- Connect the equipment into an outlet on a circuit different from that to which the receiver is connected.
- Consult the dealer or an experienced radio/TV technician for help.

VCR Plus+, C³ and PlusCode are registered trademarks of Gemstar Development Corporation. The VCR Plus+ system is manufactured under license from Gemstar Development Corporation.

DSS™ is an official trademark of DIRECTV, Inc., a unit of GM Hughes Electronics. DISH Network™ is a trademark of EchoStar Communications Corporation.



- Manufactured under licence from Dolby Laboratories. “Dolby” and double-D symbol are trademarks of Dolby Laboratories.
- “DTS” and “DTS Digital Out” are trademarks of Digital Theater Systems, Inc.
- This product incorporates copyright protection technology that is protected by method claims of certain U.S. patents and other intellectual property rights owned by Macrovision Corporation and other rights owners. Use of this copyright protection technology must be authorized by Macrovision Corporation, and is intended for home and other limited viewing users only unless otherwise authorized by Macrovision Corporation. Reverse engineering or disassembly is prohibited.

When the equipment is installed in a cabinet or a shelf, make sure that it has sufficient space on all sides to allow for ventilation (10 cm or more on both sides, on top and at the rear).

When discarding batteries, environmental problems must be considered and the local rules or laws governing the disposal of these batteries must be followed strictly.

Failure to heed the following precautions may result in damage to the unit, Remote or disc.

1. **DO NOT place the unit** —
 - in an environment prone to extreme temperatures or humidity.
 - in direct sunlight.
 - in a dusty environment.
 - in an environment where strong magnetic fields are generated.
 - on a surface that is unstable or subject to vibration.

2. **DO NOT block the unit’s ventilation openings or holes.**
(If the ventilation openings or holes are blocked by a newspaper or cloth, etc., the heat may not be able to get out.)
3. **DO NOT place heavy objects on the unit or Remote.**
4. **DO NOT place anything which might spill on top of the unit or Remote.**
(If water or liquid is allowed to enter this equipment, fire or electric shock may be caused.)
5. **DO NOT expose the apparatus to dripping or splashing.**
6. **DO NOT use this equipment in a bathroom or places with water. Also DO NOT place any containers filled with water or liquids (such as cosmetics or medicines, flower vases, potted plants, cups, etc.) on top of this unit.**
7. **DO NOT place any naked flame sources, such as lighted candles, on the apparatus.**
8. **AVOID violent shocks to the unit during transport.**

MOISTURE CONDENSATION

Moisture in the air will condense on the unit when you move it from a cold place to a warm place, or under extremely humid conditions—just as water droplets form on the surface of a glass filled with cold liquid. In conditions where condensation may occur, disconnect the unit’s power plug from the wall and keep it disconnected for a few hours to let the moisture dry, then turn on the unit.

ATTENTION

To mobile phone users:

Using a mobile phone in the vicinity of the unit may cause picture vibration on the TV screen or change the screen to a blue back display.

On placing the unit:



Some TVs or other appliances generate strong magnetic fields. Do not place such appliances on top of the unit as it may cause picture disturbance.

DISC INFORMATION	7	EDITING	86
About Discs	7	DV Dubbing	86
INDEX	12	Edit From A Camcorder	88
INSTALLING YOUR NEW UNIT	18	Edit To Or From Another Recorder	89
Basic Connections	18	Digital Audio Dubbing	90
S-VIDEO Connection	19	REMOTE	91
Component Video Connection	20	Remote Control Functions	91
INITIAL SETTINGS	21	SYSTEM CONNECTIONS	95
Plug & Play Set	21	Connecting To A Dolby Digital Decoder or An Amplifier With Built-in DTS	95
Language	22	SUBSIDIARY SETTINGS	96
Clock Set	24	Mode Set	96
Tuner Set	26	Format a disc	101
Monitor Set	28	Finalize a disc	102
Cable Box Control Setting	29	Scan Mode Set	103
DBS Receiver Control Setting	32	Tray Lock	103
PLAYBACK OPERATIONS	35	TROUBLESHOOTING	104
Basic Playback	35	GLOSSARY	108
Playback Features	36	SPECIFICATIONS	109
Live Memory Playback	41	LIST OF TERMS	110
Using Play Set Up Menu	46	FOR SERVICING (Only in U.S.A.)	111
Parental Lock	53	WARRANTY (Only in U.S.A.)	112
RECORDING	57		
Basic Recording	57		
Recording Features	58		
TIMER RECORDING	60		
VCR Plus+® Timer Programing	60		
Changing VCR Plus+® Setting	62		
Manual Timer Programing	64		
On-Disc Timer Programing	66		
Satellite Auto Recording	71		
NAVIGATION	72		
Library Database DVD Navi	72		
Modify Original Information	75		
Modify Play List Information	78		
Modify Library Information	82		
Playback with MP3/JPEG Navigation	84		

About Discs

Recordable/playable discs

You can use discs with the following logos for recording and playback.

 <p>DVD-RAM RAM 4.7</p>	12 cm: 4.7 GB/9.4 GB 8 cm: 1.4 GB/2.8 GB (VR mode) Version 2.0 Version 2.1 Version 2.1/3x
 <p>DVD-R R 4.7</p>	12 cm: 4.7 GB 8 cm: 1.4 GB (Video mode) General Version 2.0 General Version 2.0/4x General Version 2.0/8x
 <p>DVD-RW RW</p>	12 cm: 4.7 GB (Video mode/VR mode) Version 1.1 Version 1.1/2x

- The above table is based on the information as of February 2004.
- Recording and playback may not be performed with some DVD-RAM, DVD-R/-RW, and CD-R/-RW discs depending on the characteristics and condition of the disc used, leading to unsatisfactory results. Using discs manufactured by JVC is recommended since they have been tested to be compatible with this unit.

DVD-RAM Discs

It is only possible to use discs which conform with DVD-RAM standard Version 2.0 or 2.1.

- It is impossible to record on DVD-RAM discs which do not conform to this standard. If you use a disc formatted under a different standard version, format it on this unit before use.
- It may not be possible to record, play back, edit or dub a DVD-RAM disc even if it conforms to the standard if it was recorded or edited on the devices from other manufacturers or on a PC, or if it has far too many titles, or if there is very little available capacity remaining on the disc.
- DVD-RAM discs recorded on this unit cannot be played back on an incompatible DVD player.
- It is possible to record copy-once programs of digital broadcasts only onto 4.7/9.4 GB DVD-RAM discs (2.8 GB DVD-RAM discs are not compatible).

DVD-R/RW Discs

It is only possible to use DVD-R discs which conform with DVD-R standard Version 2.0.

When a DVD-R/RW disc (Video mode) is finalized (☞ pg. 102), it can be played back on a standard DVD player as a DVD VIDEO disc.

When a DVD-RW disc (VR mode) is finalized (☞ pg. 102), it can be played back on a standard DVD player compatible with the VR mode of DVD-RW discs.

- Use discs labeled "1x SPEED".
- This unit is not in compliance with DVD-RW Version 1.2.
- This unit is not in compliance with DVD+RW discs.

Before finalizing (☞ pg. 102) —

— it is possible to record on unrecorded areas of the disc, edit the disc title and program titles, and delete programs.

- Before finalizing it is possible to play or record DVD-R/RW (Video mode) discs only on this unit.
- It is impossible to overwrite recorded areas of DVD-R discs.
- Available recording capacity does not increase even if a recorded program is deleted from a DVD-R disc.

After finalizing (☞ pg. 102) —

After a DVD-R/RW disc (Video mode) has been finalized, it is possible to play back the recorded programs (video and/or audio) on a standard DVD video player as a DVD VIDEO disc.

- Edited titles are displayed as the "DVD menu" in video mode.

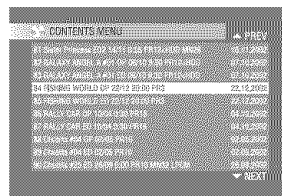

- It is impossible to record, edit or delete the data either in video mode or in VR mode.
- Either in video mode or in VR mode, although the disc can be played back on DVD players from other manufacturers, sometimes it may not be possible to play depending on the disc and recording conditions.
- It is impossible to record on CD-R/RW or DVD-R discs used for authoring.
- It is impossible to record onto DVD-R/RW (Video mode) discs broadcasts that allow you to copy once. The copy once programs can only be recorded onto DVD-RW discs formatted in VR mode.







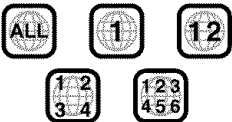

NOTES:

The following may result if you play back a DVD-R disc recorded on another unit.

- The disc does not play.
- A mosaic pattern (block noise) appears on the screen.
- Video or audio may be dropped out.
- The unit stops during playback.

Discs for Playback Only

You can use discs with the following logos for playback only.

<p>DVD VIDEO</p>  <p>(example of region code indications)</p> 	<p>Video CD/Super Video CD</p>    
<p>Audio CD</p>  <p>CD-DA files</p>	<p>CD-R</p>  <p>CD-DA/ JPEG/MP3 files</p>
<p>CD-RW</p>  <p>CD-DA/ JPEG/MP3 files</p>	<p>CD-ROM</p>  <p>JPEG/MP3 files</p>

- Playback may not be performed depending on the characteristics and condition of the disc used.
- DTS Audio CDs can also be played back (An optional DTS decoder is required).
- MP3 and JPEG discs can be played back on this unit only when they have been recorded in the ISO9660 or Joliet format and finalized.
- JPEG files that can be played back on this unit must conform to JFIF/Baseline process, and the maximum resolution of a JPEG file is 3,840 x 2,160 pixels.
- CD-R/RW discs recorded in music CD format need to be finalized to play on this unit.
- Operation and audio quality of this unit are not guaranteed for discs that do not conform to the Compact Disc specification (CD-DA).
Before you play back a CD, check for the CD logo and read the notes on the package to confirm that it conforms to the Compact Disc specification.
- Depending on the intentions of the author of the software, recording conditions of DVD discs and Video CD/SVCD discs may be restricted. Since this unit plays back discs according to the intentions of the author of the software as indicated on the disc, some functions may not operate as commanded.
- When switching from the first layer to the second layer of double-layered DVD VIDEO discs, the image and sound may be momentarily distorted. This is not a malfunction.
- DVD-AUDIO discs compatible with DVD video players can be played.
- Super Audio CDs (SACD) compatible with conventional CD players can be played.

Unplayable Discs

The following types of discs cannot be played using this unit. Do not attempt to play back any kind of disc that is damaged (cracked, warped, or repaired with adhesive tape) or discs in unusual shapes (heart-shaped, octagonal, or other forms). If such discs are accidentally played back, it may cause noise that can lead to speaker damage.

- CD-ROM discs (including PHOTO-CD and CD-G)
- Discs recorded in Packet Write (UDF) format.
- 1.3-GB double density CDs (DDCD)
- High density CDs (HDCD)

The following discs also cannot be played back.

- Discs of a region number other than "1"
- DVD-RAM (2.6 GB/5.2 GB)









Region Number

The world is divided into 6 regions for DVD VIDEO discs. DVD VIDEO discs are assigned a region number to indicate which region they may be played back in. A disc cannot be played back on this unit unless the region number of the disc matches that of the unit. The region number for this unit is "1". Only discs whose region number includes "1" or "ALL" can be played back such as shown below.

Examples of DVD VIDEO labels which can be played back using this unit.



Marks of discs in this instruction manual

	Allows operation with a DVD-RAM disc.		Allows operation with a Video CD/Super Video CD (SVCD) disc.
	Allows operation with a DVD-R disc.		Allows operation with an Audio CD disc.
	Allows operation with a DVD-RW disc.		Allows operation with a disc including MP3 files.
	Allows operation with a DVD VIDEO disc.		Allows operation with a disc including JPEG files.

Recording Medium and Format

DVD-RAM

- Recording and erasing can be performed as many times as possible on a disc.
- Editing can be performed after recording, such as deleting unwanted parts.
- While recording, it is possible not only to start playback of a program currently being recorded, but also to watch another program previously recorded.

DVD-RW (VR mode)

- Recording and erasing can be performed as many times as possible on a disc.
- Editing can be performed after recording, such as deleting unwanted parts.

DVD-RW (Video mode)

- Can be played back on other DVD players.
- New recording can be performed by erasing all the data on a disc once played back.

DVD-R

- Can be played back on other DVD players.
- Suitable when keeping a recorded disc for a long time.

File Structure of Discs

DVD VIDEO

Typically, DVD VIDEO discs are made up of larger units called "titles". Each title has a number (title number) that can be used to select desired titles. Titles are further divided into units called "chapters". Each chapter has a number (chapter number) that can also be used to select desired chapters. Note that some discs are not divided into titles and chapters.

When you record a program on a DVD-RAM/RW (VR mode) disc

A single recording session results in a single title (a single chapter). However, chapter marks are automatically inserted when recording is paused, or audio changes from monaural or bilingual to stereo due to commercial breaks, etc. It is also possible to insert chapter marks at desired locations during playback. (☞ pg. 38)

When you record a program on a DVD-R/RW (Video mode) disc

A single recording session results in a single title (a single chapter). However, chapter marks are automatically inserted when recording is paused, or audio changes due to commercial breaks, etc. It is also possible to insert chapter marks at desired locations during either recording or playback. Once the disc has been finalized, these chapter marks are deleted and new chapter marks are assigned automatically approximately every 5 minutes.

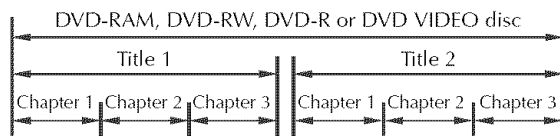

- In Video mode, even before finalizing, it is impossible to perform editing operations other than changing the disc name and/or title names and deleting programs and/or titles.
- After finalizing, it is impossible to perform editing operations.

Audio CD/Video CD/SVCD

Typically, Audio CD discs are divided into separate tracks each containing one song. Each track is assigned a number. For example, the third track is Track 3. The same is true for Video CD/SVCD discs.

However, some discs are not divided into tracks.

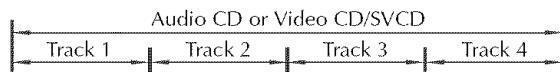

JPEG/MP3 Disc (CD-R/RW/ROM)

MP3/JPEG files put in directories nested in several levels on a disc will be organized as if they were put in single level directories (groups) by the MP3/JPEG Navigation of this unit. (pg. 84)

File structure of a disc before starting the MP3/JPEG Navigation

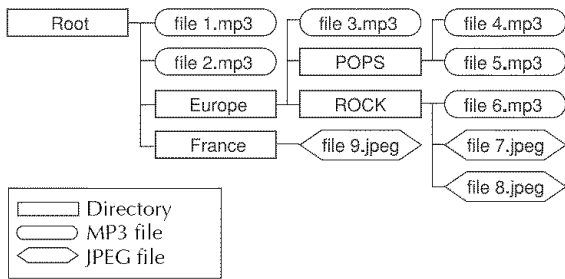

File structure of the disc after starting the MP3/JPEG Navigation

Files are automatically grouped as follows and displayed on the MP3/JPEG Navigation screen. Data is displayed in the alphabetical order of file name. Files are grouped based on roots.



- This unit can recognize up to 9 hierarchies including directories and files. Also, it can recognize up to 250 files in each group, and up to 99 groups on a disc.

NOTES:

- **Video CD/SVCD discs that support Playback Control (PBC)**
The contents of a disc are recorded into several hierarchies, and played back according to the instructions on the screen while navigating through the hierarchies. It is also possible to playback recorded tracks consecutively without activating the PBC function even when playing a PBC-compatible disc. (pg. 40)
- **Regarding the contents recorded on discs**
Some files may not be played back depending on the file types and other factors.

DVD VIDEO Marks

Sometimes marks are printed on a DVD disc and/or on its packaging to indicate information regarding the contents and functions of the disc. Check the marks indicating the contents and functions of the disc. Note, however, that in some cases a disc may not include a mark even for a function it supports.

Marks related to video

Mark	Description
	Number of subtitles
	Number of angles
	Recorded under the standard 4:3 aspect ratio
	Screen includes black bands at the top and the bottom of image which has a standard 4:3 aspect ratio (letter box)
	Video playback is in Wide video mode (16:9) on wide televisions, but in letter box on televisions with standard 4:3 aspect ratio.
	Video playback is in Wide video mode (16:9) on wide televisions, but pan and scan is used on televisions with standard 4:3 aspect ratio (either the left or right side of the image is cut-out).

Marks related to audio

Mark	Description
	Number of audio tracks
	Dolby Digital mark It has been developed by Dolby Laboratories as a digital surround system.
	DTS (Digital Theater Systems) You can enjoy DTS audio if you connect an amplifier with a built-in DTS decoder to the DIGITAL OUT connector of the unit.

Placing a Disc

Opening the disc tray

Press ▲ on the unit or Remote to open the disc tray.

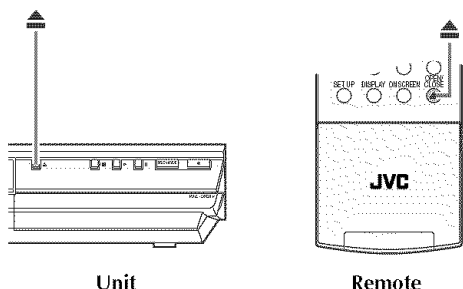

Unit

Remote

- Pressing the button on the unit or on the Remote again closes the disc tray.
- Use the buttons on the unit or on the Remote to open and close the disc tray.
- Do not block the disc tray with your hand while it is opening or closing as this may result in hardware failure.
- Do not place unplayable discs or any object other than a disc on the disc tray.
- Do not press down strongly on the disc tray or place any heavy objects on it.

Discs without cartridges

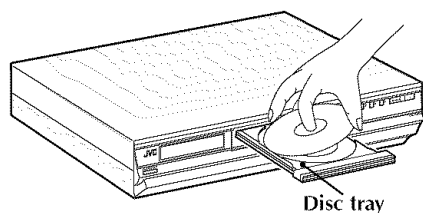

Disc tray

Place the disc on the disc tray with the label side facing up. Since disc size changes depending on the disc to be played back, be sure to correctly align the disc with the grooves for its size. If the disc is not in its groove, it may be scratched or otherwise damaged. To insert an 8 cm disc, place it according to the inner groove.

DVD-RAM discs contained in cartridges

Double-sided discs:

Remove the disc from the cartridge. Align the disc with the grooves on the disc tray as shown in the illustration and insert with the side you wish to play back or record facing down. If you insert the disc with "Side A" facing down, programmes are recorded on the side A.

Single-sided discs:

Remove the disc from the cartridge. Align the disc with the grooves on the disc tray as shown in the illustration and insert with the label side facing up.

NOTE:

To prevent accidental erasure of important recordings, slide the protect tab to the protect position using a ballpoint pen, etc. Release the protect tab to record, edit, or perform other operations.

Care and Handling of Discs

How to handle discs

When handling a disc, do not touch the surface of the disc. Since discs are made of plastic, they are easily damaged. If a disc gets dirty, dusty, scratched or warped, the images and sound will not be picked up correctly, and such a disc may cause the unit to malfunction.

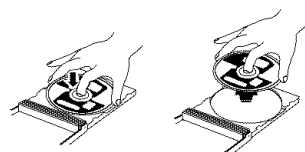

Label side

Do not damage the label side, stick paper to or use any adhesives on its surface.

Recording side

Make sure that discs are not scratched and dirty on the recording side before use. Scratches and dirt on the recording side of a disc may hinder proper playback and recording. Also be careful that a DVD-RAM disc may get scratched or dirt when removed from cartridge then put back in after use.

Storage

Make sure that discs are kept in their cases. If discs are piled on top of one another without their protective cases, they can be damaged. Do not put discs in a location where they may be exposed to direct sunlight, or in a place where the humidity or temperature is high. Avoid leaving discs in your car!

Maintenance of discs

If there are fingerprints or other dirt adhering to a disc, wipe with a soft dry cloth, moving from the centre outwards. If a disc is difficult to clean, wipe with a cloth moistened with water. Never use record cleaners, petrol, alcohol or any anti-static agents.

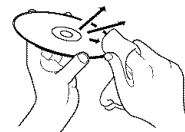

CAUTION

Sometimes during playback, noise may appear or images may be garbled. This is sometimes due to the disc. (It may not be up to industry standards.)

These symptoms are caused by the discs, not by the malfunction of the unit.

FRONT VIEW

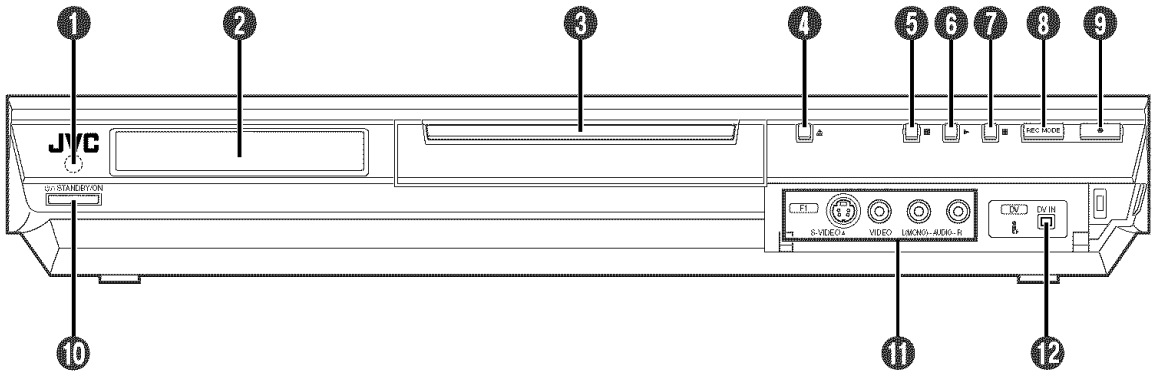

- ① Infrared Beam Receiving Window
- ② Front Display Panel ☞ pg. 14
- ③ Disc Tray
- ④ Open/Close Button (▲) ☞ pg. 11
- ⑤ Stop Button (■) ☞ pg. 35, 57
- ⑥ Play Button (▶) ☞ pg. 35
- ⑦ Pause Button (⏸) ☞ pg. 35
- ⑧ Recording Mode Button (REC MODE) ☞ pg. 57

- ⑨ Record Button (●) ☞ pg. 57
- ⑩ Standby/On Button (⏻/⏼ (STANDBY/ON))
- ⑪ S-video/Video/Audio Input Connectors (S-VIDEO/VIDEO/AUDIO (L/R)) ☞ pg. 88
- ⑫ DV Input connector (DV IN (i*)) ☞ pg. 86

* i.Link refers to the IEEE1394-1995 industry specification and extensions thereof. The i.Link logo is used for products compliant with the i.Link standard.

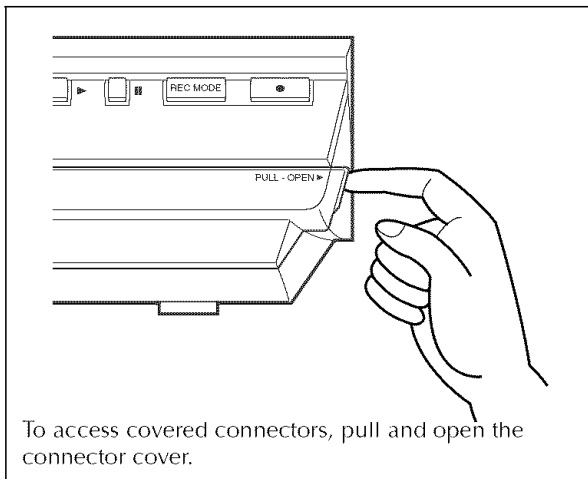

To access covered connectors, pull and open the connector cover.

REAR VIEW

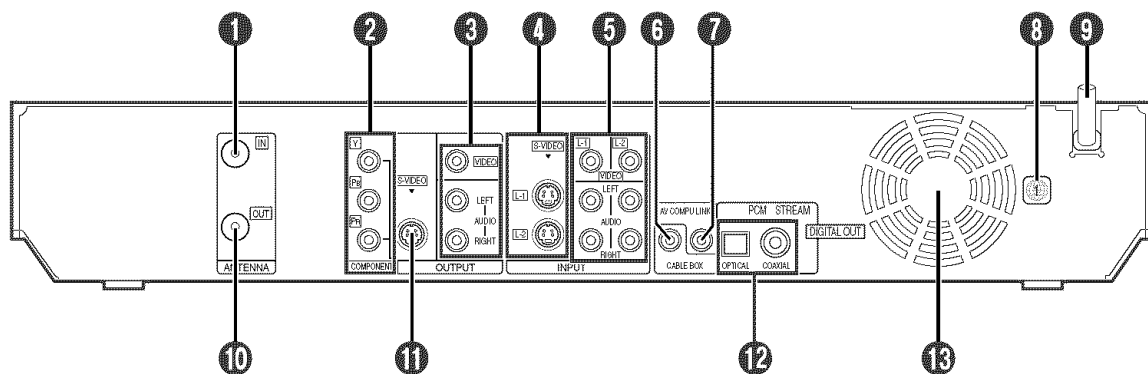

- 1** Antenna Input Connector (ANTENNA IN)
 ☞ pg. 18
- 2** Component Video Output Connectors (COMPONENT OUTPUT) ☞ pg. 20
- 3** Video/Audio Output Connectors (VIDEO/AUDIO OUTPUT) ☞ pg. 18, 19, 20, 89
- 4** S-video Input Connector (S-VIDEO INPUT)
 ☞ pg. 19
- 5** Video/Audio Input Connectors (VIDEO/AUDIO INPUT (L-1/L-2)) ☞ pg. 89
- 6** Cable Box Control Connector (CABLE BOX)
 ☞ pg. 29, 32
- 7** AV COMPU LINK Connector ☞ pg. 100
- 8** Region Number Label ☞ pg. 8
- 9** Mains Power Cord ☞ pg. 18
- 10** Antenna Output Connector (ANTENNA OUT)
 ☞ pg. 18
- 11** S-video Output Connector (S-VIDEO OUTPUT)
 ☞ pg. 19
- 12** Digital Audio Output Connectors (DIGITAL OUT (COAXIAL/OPTICAL))
 ☞ pg. 90, 95
- 13** Cooling Fan
 - This prevents the temperature from rising inside the unit. Do not remove it.
 - Install the unit so as not to block the area around the fan.
 - The cooling fan on the rear of the unit may be activated even if the unit is turned off in the following cases:
 - in the REC LINK standby mode (☞ pg. 71)
 - when “AUTO CLOCK” is set to “ON” (☞ pg. 24)

FRONT DISPLAY PANEL

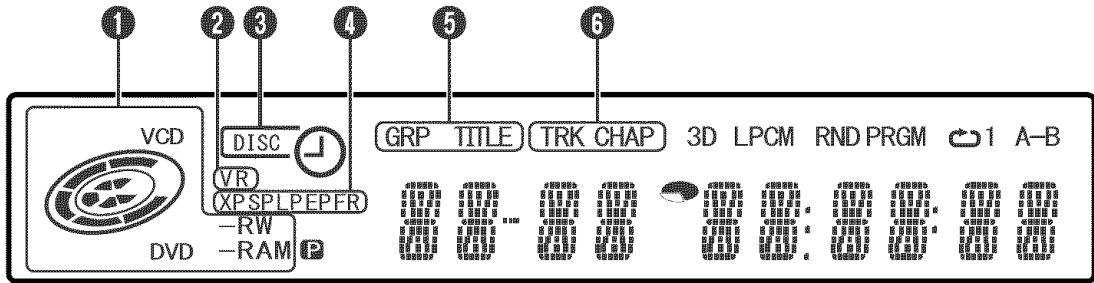
**1** Disc Type/Status Indicator

When a disc is loaded, the type of the disc is indicated.

When a disc is running, the disc marks rotate.

During High-Speed Search: Rotate faster than normal playback.

During Slow Motion: Rotate slower than normal playback.

While recording: Inner red ring lights in the same way as normal playback. During Instant Timer Recording (ITR), inner red ring slowly blinks.

While paused: Disc marks blink when either recording or playing back.

While stopped: Disc marks all light.

While resume stopped: Disc marks all blink.

While the disc tray opened: Disc marks all light out.

No disc on the disc tray: Disc marks all light out.



2 VR Mode Indicator  pg. 101



Lights when a DVD-RW disc is formatted in VR mode.

3 Timer Recording Indicator  pg. 60, 64, 66, 69

: Lights when a disc set up for On-Disc Timer Programming is loaded.

: Lights when timer recording other than On-Disc Timer Programming is on stand-by or being executed.

 : Lights when On-Disc Timer Programming is on stand-by or being executed.



: Blinks quickly if you press  (TIMER) in the following cases;

- Disc is not loaded.
- Clock has not been set.
- There is no program setting.

4 Recording Mode Indicator (XP/SP/LP/EP/FR)

 pg. 58

Blinks when recording mode is being set.

While "FR" is blinking, the left 3 digits of the Multi Display   indicate setting values ranging from "60" to "480".

After the value has been set, only "FR" lights.

5 Group/Title Indicator (GRP/TITLE)  pg. 9, 49

"GRP" or "TITLE" lights depending on a disc loaded while the left 2 digits of the Multi Display  indicate the numbers explained below.

"GRP": Total number of groups or group number being played back are displayed on the Multi Display.

"TITLE": Total number of titles or title number being played back are displayed on the Multi Display.

6 Track/Chapter Indicator (TRK/CHAP)  pg. 9, 49

"TRK" or "CHAP" lights depending on a disc loaded while the 3rd and 4th digits from the left of the Multi Display  indicate the numbers explained below.

"TRK": Total number of tracks or track number being played back are displayed on the Multi Display.

"CHAP": Chapter number being played back are displayed on the Multi Display.

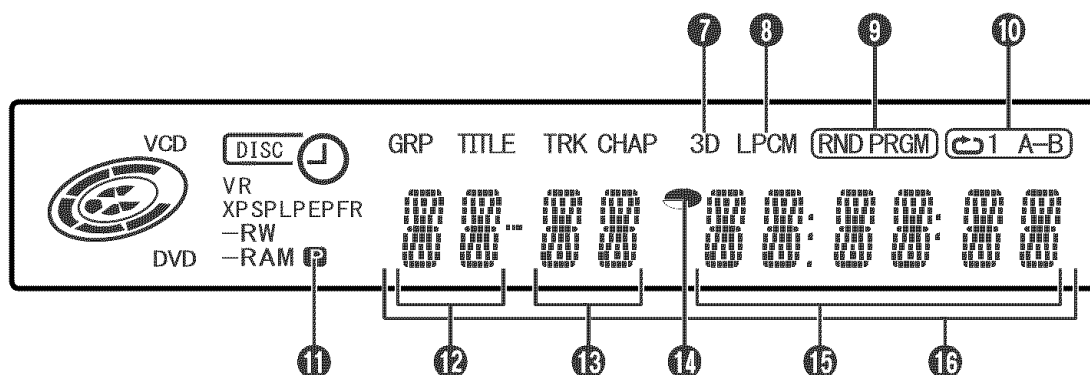

7 Simulated Surround Effect Indicator (3D)

☞ pg. 50

Lights when a simulated surround effect is set to "3D-ON" in Play Set Up menu.

8 Linear PCM Indicator (LPCM)

Lights when "XP MODE REC AUDIO" is set to "LINEAR PCM" (☞ pg. 98) for recording with DVD-RAM, DVD-R and DVD-RW discs, and when Linear PCM audio is played.

9 Random/Program Playback Mode Indicator (RND/PRGM)

"RND": Lights when Random Playback mode is set.

(☞ pg. 52)

"PRGM": Lights when Program Playback mode is set.

(☞ pg. 52)

10 Repeat Mode Indicator (A-B) ☞ pg. 48, 49

Select Repeat Playback mode in Play Set Up menu.

"A": Whole disc is played back repeatedly.

"1": A single title/chapter/track is played back repeatedly.

"A-B": The selected part (A-B) is played back repeatedly.

No display: Repeat Playback mode is off.

11 Video Output Indicator (P) ☞ pg. 103

No display: Indicates that interlace mode is engaged.

P: Indicates that progressive mode is engaged.

(Example) P lights when video output mode is in progressive mode.

12 Group/Title Number Display ☞ pg. 9, 49

13 Track/Chapter Number Display ☞ pg. 9, 49

14 Remaining Time/Elapsed Time Indicator

☞ pg. 38, 58

Lights when remaining time of DVD-RAM, DVD-R and DVD-RW discs is displayed, and lights out when elapsed time is displayed.

The right 6 digits of the Multi Display (16) indicate elapsed or remaining time of each track.

No display: Indicates elapsed time of the disc.

Displayed: Indicates remaining time of the disc.

15 Remaining Time/Elapsed Time Display

☞ pg. 38, 58

16 Multi Display

Displays clock, received channel, elapsed time, and remaining time.

Also displays status of the unit (NO DISC/OPEN/CLOSE/READING).

ON-SCREEN DISPLAY

When "SUPERIMPOSE" is set to "AUTO" and **ON SCREEN** on the Remote is pressed in Record mode, various operational indicators appear on the TV screen. To clear the operational indicators, press **ON SCREEN** again.

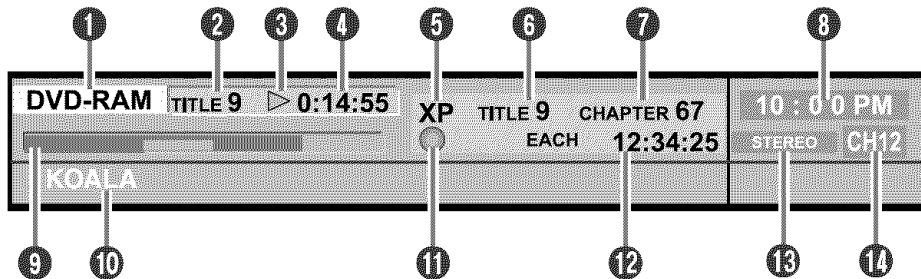

- 1** Disc Display
Displays the type of the disc loaded on the disc tray.
- 2** Title Number*
Displays number of the title currently being played back.
- 3** Playback Operation Status Indicator*
Indicates playback operation status by pictographs.
- 4** Playback Time*
Displays playback time of the title currently being played back.
- 5** Recording Mode
Displays recording mode as XP, SP, LP, EP, FR, FR60–FR360, FR420 and FR480. Current recording mode is displayed during recording, and recording mode in which the program was recorded is displayed during playback. The recording mode is not displayed during play list playback.
- 6** Title Number
Displays playback title number during playback, and recording title number during recording.
- 7** Chapter Number
Displays playback chapter number during playback, and recording chapter number during recording.
- 8** Clock Display
- 9** Bar Meter Display  pg. 43
Displays playback point and other information in bar meter.
- 10** Title Name Display
Displays title name newly registered to the title recorded on DVD-RAM/RW/R discs, or file name of JPEG and MP3 files.
- 11** Operation Status Indicator
Indicates operation status by pictographs. (Also indicates its speed for forward high-speed search, reverse high-speed search and slow motion.)
- 12** Time Display
Displays single title playback elapsed time, single track playback elapsed time, single track remaining time, total elapsed time, total remaining time, and other information in turn.
- 13** Audio Display
Displays audio that is being input.
- 14** Input Display
Displays currently selected input.

* During Live Memory playback, playback operation status is displayed. During normal playback, the multichannel encoding method is displayed.

REMOTE

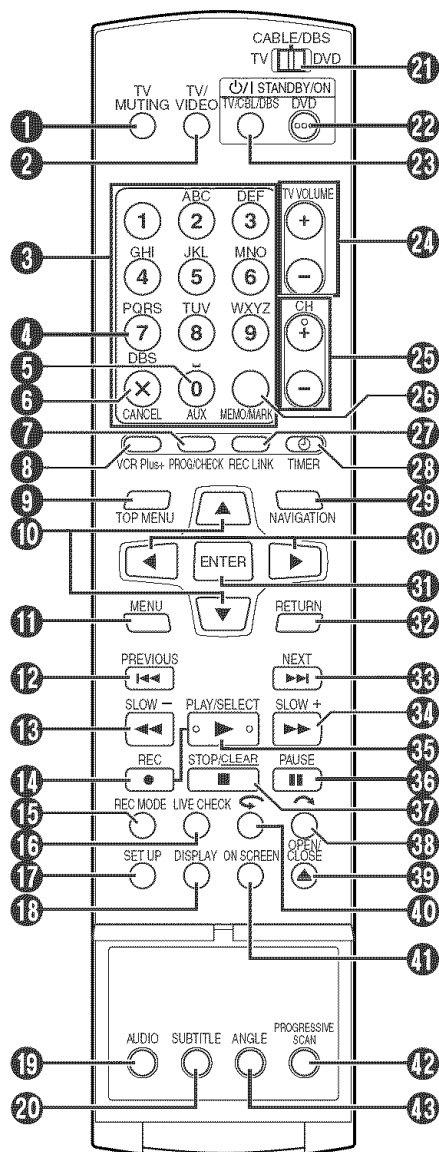

- 1 TV Muting Button (TV MUTING) ☞ pg. 92
- 2 TV/VIDEO Button ☞ pg. 58
- 3 Number Keys ☞ pg. 36, 53, 57, 60, 91
Character Keys ☞ pg. 76
- 4 DBS Button ☞ pg. 65
- 5 Auxiliary Button (AUX) ☞ pg. 65
- 6 Cancel Button (X (CANCEL))
☞ pg. 53, 60, 69, 85
- 7 Program Check Button (PROG/CHECK) ☞ pg. 69
- 8 VCR Plus+ Button ☞ pg. 60
- 9 Top Menu Button (TOP MENU) ☞ pg. 36
- 10 Δ / ∇ Button ☞ pg. 28
- 11 Menu Button (MENU) ☞ pg. 36
- 12 Reverse Skip Button (◀◀) ☞ pg. 36, 44
Previous Button (PREVIOUS) ☞ pg. 40
- 13 Reverse Search Button (◀◀) ☞ pg. 37, 44
Reverse Slow Button (SLOW -) ☞ pg. 37
- 14 Record Button (● (REC)) ☞ pg. 57

- 15 Recording Mode Button (REC MODE) ☞ pg. 57
- 16 Live Check Button (LIVE CHECK) ☞ pg. 44
- 17 Set Up Button (SET UP) ☞ pg. 28
- 18 Display Button (DISPLAY) ☞ pg. 16, 38, 43, 58
- 19 Audio Button (AUDIO) ☞ pg. 39
- 20 Subtitle Button (SUBTITLE) ☞ pg. 39
- 21 TV/CABLE/DBS/DVD switch ☞ pg. 28
- 22 DVD Standby/On Button (DVD ψ /I (STANDBY/ON))
- 23 TV/CABLE/DBS Standby/On Button (TV/CBL/DBS ψ /I (STANDBY/ON)) ☞ pg. 92
- 24 TV Volume Button (TV VOLUME +/-) ☞ pg. 92
- 25 Channel Button (CH +/-) ☞ pg. 94
- 26 Memo Button (MEMO) ☞ pg. 74, 81, 85
Mark Button (MARK) ☞ pg. 38
- 27 Satellite Auto Recording Button (REC LINK)
☞ pg. 71
- 28 Timer Button (⊖ (TIMER)) ☞ pg. 61, 65
- 29 Navigation Button (NAVIGATION) ☞ pg. 72
- 30 \triangleleft / \triangleright Button ☞ pg. 22, 44
- 31 Enter Button (ENTER) ☞ pg. 22
- 32 Return Button (RETURN) ☞ pg. 40, 60
- 33 Forward Skip Button (▶▶) ☞ pg. 36, 44
Next Button (NEXT) ☞ pg. 40
- 34 Forward Search Button (▶▶) ☞ pg. 37, 44
Forward Slow Button (SLOW +) ☞ pg. 37
- 35 Play Button (▶ (PLAY)) ☞ pg. 35
Select Button (SELECT)
- 36 Pause Button (|| (PAUSE)) ☞ pg. 35, 44
- 37 Stop Button (■) ☞ pg. 35, 44, 57, 86
Clear Button (CLEAR) ☞ pg. 37, 60
- 38 Skip Search Button (◁) ☞ pg. 37, 44
- 39 Open/Close Button (▲ (OPEN/CLOSE)) ☞ pg. 11
- 40 One Touch Replay Button (↺) ☞ pg. 44, 45
- 41 Play Set Up Button (ON SCREEN) ☞ pg. 46
- 42 Progressive Scan Button (PROGRESSIVE SCAN)
☞ pg. 103
- 43 Angle Button (ANGLE) ☞ pg. 39

How To Use

Before use, insert two AA size batteries into the Remote with the polarity (\oplus and \ominus) matched correctly as indicated on the battery compartment or on the lid.

The Remote can operate most of your unit's functions, as well as basic functions of TV sets of JVC and other brands. (☞ pg. 92)

- Point the Remote toward the remote sensor.
- The maximum operating distance of the remote control is about 8 m. (26.25ft)

NOTES:

- When inserting the batteries, be sure to insert in the correct directions as indicated under the battery cover.
- If the Remote doesn't work properly, remove its batteries, wait for approximately 5 minutes, replace the batteries and then try operating the unit again.

Basic Connections

It's essential that your unit be properly connected.

THESE STEPS MUST BE COMPLETED BEFORE ANY VIDEO OPERATION CAN BE PERFORMED.

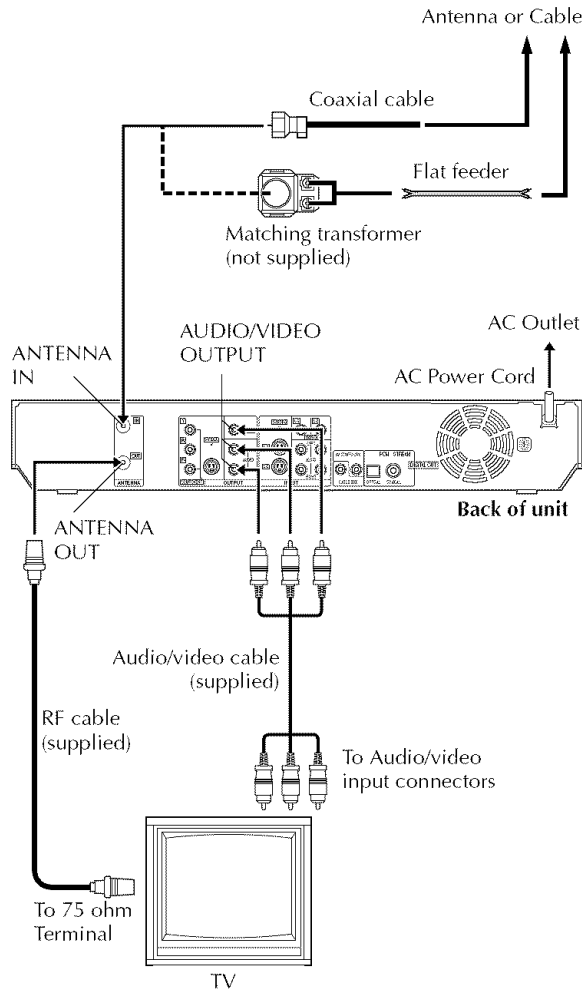

1 Check the contents.

Make sure the package contains all of the accessories listed in "SPECIFICATIONS" on page 109.

2 Install the unit.

Place the unit on a stable, horizontal surface.

3 Connect the unit to a TV.

- 1 Disconnect the TV antenna from the TV.
 - 2 Connect the TV antenna cable to the ANTENNA IN connector on the rear panel of the unit.
 - 3 Connect the supplied RF cable between the ANTENNA OUT connector on the rear panel of the unit and the TV's antenna connector.
 - 4 Connect the supplied audio/video cable between the AUDIO/VIDEO OUTPUT connectors on the rear panel of the unit and the TV's audio/video input connectors.
- Set your TV to AV mode.
 - For switching the TV's mode, refer to the instruction manual of your TV.

4 Connect the unit to power source.

Plug the end of the AC power cord into an AC outlet. This unit performs Plug & Play Set automatically. (pg. 21)

- The clock and tuner channels will automatically be set when the antenna is connected and when the AC power cord is first connected to an AC outlet. (If "AUTO" and the channel indicator are displayed on the front display panel before the unit is powered on, the clock and tuner channels are being set automatically. Wait for the time to be displayed on the front display panel before turning on the unit.)

NOTES:

- It requires the RF connection to enjoy TV programs.
- The playback image is not displayed without one of the following: A/V, S-Video, or Component Video connection.

S-VIDEO Connection

■ To connect to TV's S-VIDEO input and AUDIO input connectors

1 Connect the unit to a TV.

- 1 Connect the antenna, unit and TV as per "Basic Connections" (pg. 18).
- 2 Connect the unit's S-VIDEO OUTPUT connector to the TV's S-VIDEO input connector.
- 3 Connect the unit's AUDIO OUTPUT connectors to the TV's AUDIO input connectors.

2 Connect the unit to power source.

Plug the end of the AC power cord into an AC outlet. This unit performs Plug & Play Set automatically. (pg. 21)

- The clock and tuner channels will automatically be set when the antenna is connected and when the AC power cord is first connected to an AC outlet. (If "AUTO" and the channel indicator are displayed on the front display panel before the unit is powered on, the clock and tuner channels are being set automatically. Wait for the time to be displayed on the front display panel before turning on the unit.)

NOTES:

- You can obtain high-quality S-VHS pictures.
- If your TV is not stereo-capable, use the unit's AUDIO OUTPUT connectors to connect to an audio amplifier for Hi-Fi stereo sound reproduction.
- For switching the TV's video input mode, refer to the instruction manual of your television.

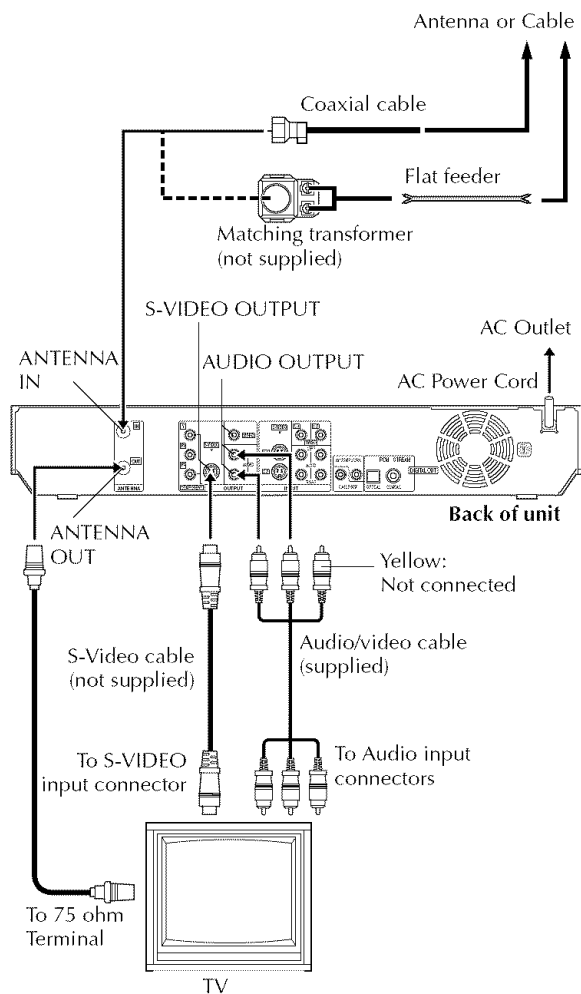

Component Video Connection

Component video connection enables you to obtain high-quality component video pictures.

■ To connect to TV's component video input connectors

1 Connect the unit to TV.

- 1 Perform 1 – 3 in step 2 in "Basic Connections" (pg. 18).
- 2 Connect the unit's COMPONENT OUTPUT connectors to the TV's component video input connectors.
- 3 Connect the unit's AUDIO OUTPUT connectors to the TV's AUDIO input connectors.

2 Connect the unit to power source.

Plug the end of the AC power cord into an AC outlet. This unit performs Plug & Play Set automatically. (pg. 21)

- The clock and tuner channels will automatically be set when the antenna is connected and when the AC power cord is first connected to an AC outlet. (If "AUTO" and the channel indicator are displayed on the front display panel before the unit is powered on, the clock and tuner channels are being set automatically. Wait for the time to be displayed on the front display panel before turning on the unit.)

NOTES:

- If your TV is not stereo-capable, use the unit's AUDIO OUTPUT connectors to connect to an audio amplifier for Hi-Fi stereo sound reproduction.
- For switching the TV's video input mode, refer to the instruction manual of your television.

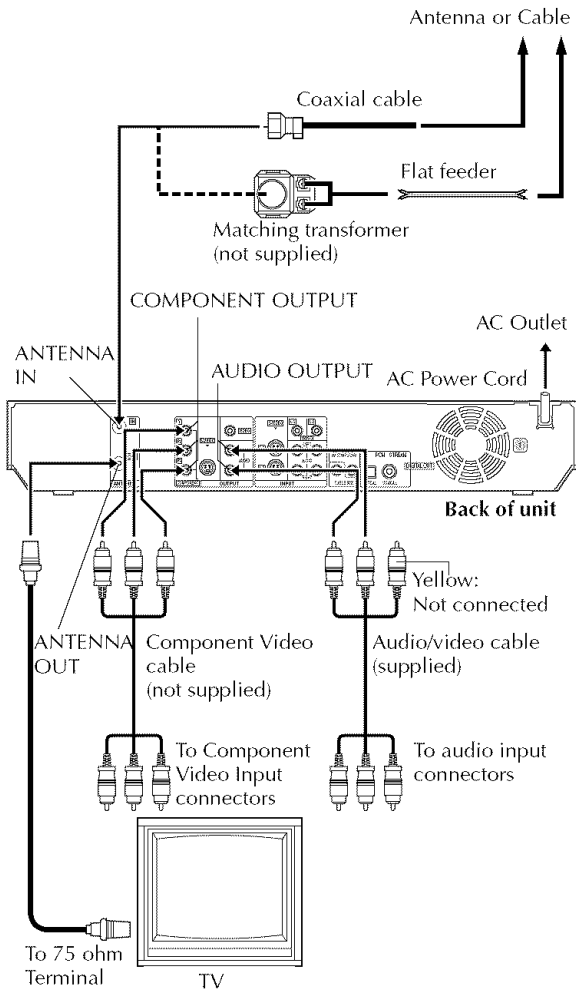

Plug & Play Set

Auto Clock Set/Auto Tuner Set

ATTENTION:

- If you use a cable box, Plug&Play will not function; set the clock and tuner channels separately. (☞ pg. 24 – 27)
- Depending on areas or reception conditions, the unit may not receive the Auto clock setting data from the PBS channel. If this function is taking a considerable amount of time, it may be necessary to perform the Semiauto or Manual Clock Set procedure.

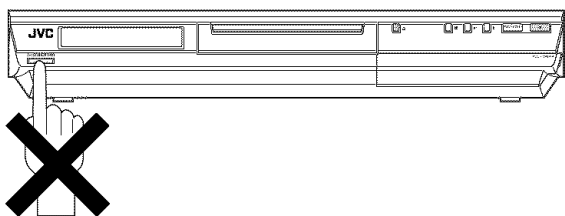

This unit sets the clock and tuner channels automatically when AC power cord is first connected to an AC outlet. The antenna cable must be connected for the Plug & Play setting.

The time and date can be set automatically by the clock setting data transmitted from one of the regular TV broadcast channels. We call this TV channel the “host channel” and it is a PBS channel in your area.

1 Perform Plug & Play setup.

Connect the antenna cable to the unit. (☞ pg. 18) Then connect the AC power cord to an AC outlet. Do not turn on the unit.

The clock and tuner channels will be set automatically.

NOTES:

- Auto Clock Set is performed first. “AUTO” blinks on the front display panel during Auto Clock Set.
- Auto Channel Set is performed next. Auto Channel Set scans all the channels that are receivable by your unit. During Auto Channel Set, the channel numbers are displayed as they are scanned and set.
- When Plug & Play setting has been complete successfully, the correct clock time is displayed. If you perform Plug & Play setting successfully, there is no need to perform “Clock Set” (☞ pg. 24) and “Tuner Set” (☞ pg. 26). If, however, you want to add or delete channels, refer to “Manual Channel Set” (☞ pg. 27).

During Auto Clock Set
“AUTO” blinks.

During Auto Channel Set
The channel numbers are displayed as they are scanned and set.

Plug&Play Completed
The current time is displayed.

* If an incorrect clock time or “-:-:-” appears on the front display panel, see “What to do if Plug & Play setting failed” below.

INFORMATION

- If “AUTO CLOCK” is set to “ON” (☞ pg. 24), the clock will be adjusted automatically by the host channel every hour (except 11:00 PM, midnight, 1:00 AM and 2:00 AM) using the incoming PBS channel clock setting data. (This automatic clock adjustment can only be performed when the unit is turned off. The clock will be adjusted just on these hours — on the time displayed on the front display panel, not on the actual real time.) The default setting of “AUTO CLOCK” is “ON”. (☞ pg. 24)
- If the memory backup fails, because a power outage occurs or because the AC power cord is unplugged, Plug & Play will be performed when power is restored to the unit.

What to do if Plug & Play setting failed

- If an incorrect time is displayed on the front display panel, you may be receiving the clock setting data of a PBS channel from an adjacent time zone, or an incorrect PBS channel from a cable TV system. In this case, perform “Semiauto Clock Set” (☞ pg. 24) or “Manual Clock Set” (☞ pg. 25).
- If “-:-:-” appears on the front display panel, your antenna cable may not be connected to the unit or there may not be a Host PBS signal available in your area. Ensure that the antenna cable is connected correctly. Then turn on and off the unit; the Plug & Play setting will be automatically reactivated. If Plug & Play setting is not performed though the antenna cable is connected correctly, perform “Manual Clock Set” (☞ pg. 25) and “Auto Channel Set” (☞ pg. 26) or “Manual Channel Set” (☞ pg. 27).

Language

- Turn on the unit.
- Turn on the TV and select the AV mode.
- Slide the TV/CABLE/DBS/DVD switch to DVD.

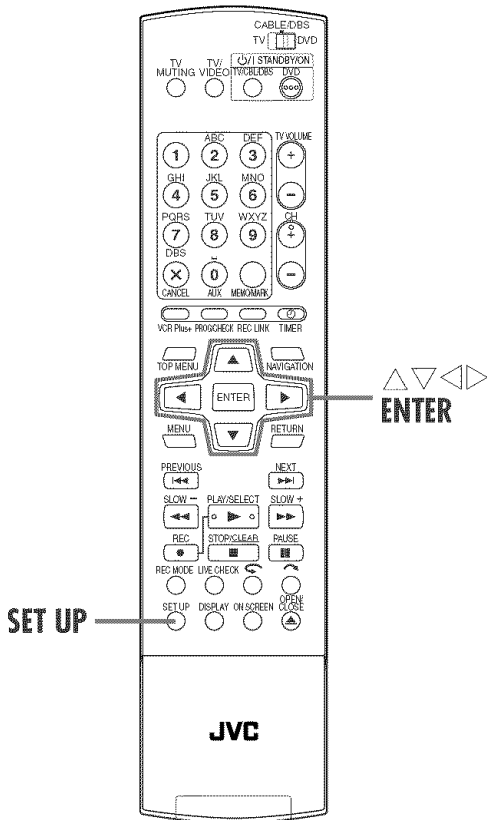

On-screen Language Set

This unit offers you the choice to view on-screen messages in 3 different languages.

1 Access the Main Menu screen.

Press **SET UP**.

2 Access the "DISPLAY SET" screen.

- 1 Press $\triangleleft \triangleright$ to move the arrow to "FUNCTION SET UP", then press **ENTER**.
- 2 Press $\triangleleft \triangleright$ to move the arrow to "DISPLAY SET", then press **ENTER**.

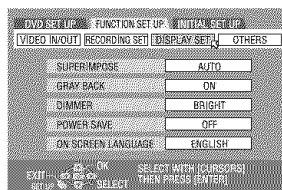

3 Select the desired language.

- 1 Press $\triangle \nabla$ to move the arrow to "ON SCREEN LANGUAGE", then press **ENTER**.
- 2 Press $\triangle \nabla$ to select your desired language, then press **ENTER**.

4 Complete the setting.

Press **SET UP**.

Menu/Audio/Subtitle Language Set

Some DVD discs contain the DVD menu display, audio and subtitles in multiple languages. With these discs, you can set the default language as you like.

- The procedure shows how to set "MENU LANGUAGE" as an example.

1 Access the Main Menu screen.

Press **SET UP**.

2 Access the "LANGUAGE SET" screen.

- 1 Press $\triangleleft \triangleright$ to move the arrow to "DVD SET UP", then press **ENTER**.
- 2 Press $\triangleleft \triangleright$ to move the arrow to "LANGUAGE SET", then press **ENTER**.

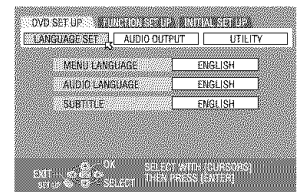

3 Select the desired language.

- 1 Press $\triangle \nabla$ to move the arrow to "MENU LANGUAGE", then press **ENTER**.
 - See "Language Code List" (pg. 23).
- 2 Press $\triangle \nabla$ to select your desired language, then press **ENTER**.

4 Complete the setting.

Press **SET UP**.

NOTE:

When the selected language is not available on the disc, the disc's default menu language is played back.

Language Code List

AA	Afar
AB	Abkhazian
AF	Afrikaans
AM	Ameharic
AR	Arabic
AS	Assamese
AY	Aymara
AZ	Azerbaijani
BA	Bashkir
BE	Byelorussian
BG	Bulgarian
BH	Bihari
BI	Bislama
BN	Bengali, Bangla
BO	Tibetan
BR	Breton
CA	Catalan
CO	Corsican
CS	Czech
CY	Welsh
DZ	Bhutani
EL	Greek
EO	Esperanto
ET	Estonian
EU	Basque
FA	Persian
FJ	Fiji
FO	Faroese
FY	Frisian
GA	Irish
GD	Scots Gaelic
GL	Galician
GN	Guarani
GU	Gujarati
HA	Hausa
HI	Hindi
HR	Croatian
HU	Hungarian
HY	Armenian
IA	Interlingua
IE	Interlingue

IK	Inupiak
IN	Indonesian
IS	Icelandic
IW	Hebrew
JJ	Yiddish
JW	Javanese
KA	Georgian
KK	Kazakh
KL	Greenlandic
KM	Cambodian
KN	Kannada
KO	Korean (KOR)
KS	Kashmiri
KU	Kurdish
KY	Kirghiz
LA	Latin
LN	Lingala
LO	Laothian
LT	Lithuanian
LV	Latvian, Lettish
MG	Malagasy
MI	Maori
MK	Macedonian
ML	Malayalam
MN	Mongolian
MO	Moldavian
MR	Marathi
MS	Malay (MAY)
MT	Maltese
MY	Burmese
NA	Nauru
NE	Nepali
OC	Occitan
OM	(Afan) Oromo
OR	Oriya
PA	Panjabi
PL	Polish
PS	Pashto, Pushto
PT	Portuguese
QU	Quechua
RM	Rhaeto-Romance

RN	Kirundi
RO	Rumanian
RU	Russian
RW	Kinyarwanda
SA	Sanskrit
SD	Sindhi
SG	Sangho
SH	Serbo-Croatian
SI	Singhalese
SK	Slovak
SL	Slovenian
SM	Samoan
SN	Shona
SO	Somali
SQ	Albanian
SR	Serbian
SS	Siswati
ST	Sesotho
SU	Sundanese
SW	Swahili
TA	Tamil
TE	Telugu
TG	Tajik
TH	Thai
TI	Tigrinya
TK	Turkmen
TL	Tagalog
TN	Setswana
TO	Tonga
TR	Turkish
TS	Tsonga
TT	Tatar
TW	Twi
UK	Ukrainian
UR	Urdu
UZ	Uzbek
VI	Vietnamese
VO	Volapuk
WO	Wolof
XH	Xhosa
YO	Yoruba
ZU	Zulu

Clock Set

- Turn on the unit.
- Turn on the TV and select the AV mode.
- Slide the TV/CABLE/DBS/DVD switch to DVD.

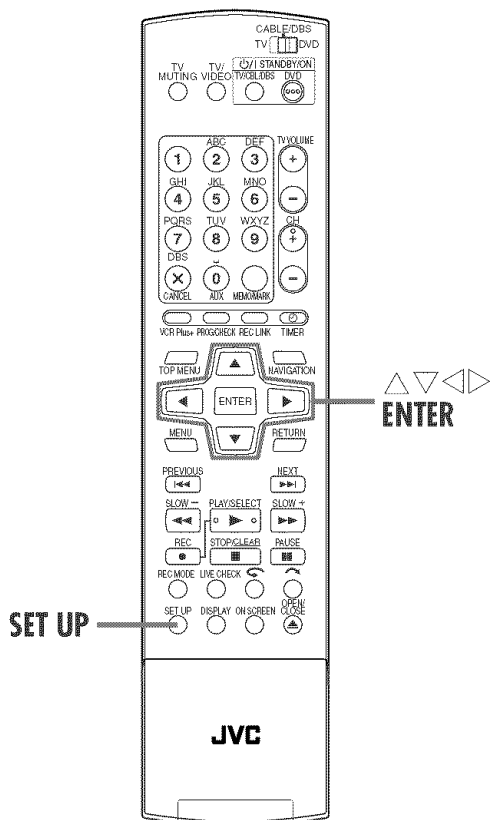

Perform clock setting only if the clock has not been set correctly by the Plug&Play setting.

Semiauto Clock Set

You can change the host channel/D.S.T. (Daylight Saving Time)/time zone setting manually.

NOTE:

The time set previously will be erased when "AUTO CLOCK", "HOST CH", "D.S.T." or "TIME ZONE" setting is changed.

1 Access the Main Menu screen.

Press SET UP.

2 Access the "CLOCK SET" screen.

- 1 Press \triangleleft \triangleright to select "INITIAL SET UP", then press ENTER.
- 2 Press \triangleleft \triangleright to select "CLOCK SET", then press ENTER.

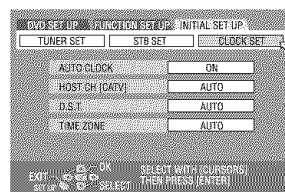

3 Set "AUTO CLOCK" to "ON".

- 1 Press \triangle ∇ to move the arrow to "AUTO CLOCK", then press ENTER.
- 2 Press \triangle ∇ until "ON" is selected, then press ENTER.

4 Select the host channel.

You can either select "AUTO" or enter a PBS channel number.

- 1 Press \triangle ∇ to move the arrow to "HOST CH", then press ENTER.
- 2 Press \triangle ∇ to select "AUTO" or the desired PBS channel number, then press ENTER.

NOTE:

Some PBS channels do not transmit clock setting data.

5 Select the D.S.T. mode.

- 1 Press \triangle ∇ to move the arrow to "D.S.T.", then press ENTER.
- 2 Press \triangle ∇ to select the desired setting, then press ENTER.

AUTO: Select if you want to adjust your unit's clock automatically by the incoming signal from the host channel. Be sure to select the correct time zone setting manually in step 3.

ON: Adjustment will be made by the built-in clock itself.

OFF: Select when Daylight Saving Time does not apply to you.

6 Select the time zone.

- Press Δ / ∇ to move the arrow to "TIME ZONE", then press **ENTER**.
- Press Δ / ∇ to select "AUTO" or the desired time zone, then press **ENTER**. Each time you press Δ / ∇ , the time zone changes as follows:
 \leftrightarrow AUTO \leftrightarrow ATLANTIC \leftrightarrow EASTERN \leftrightarrow CENTRAL \leftrightarrow
 MOUNTAIN \leftrightarrow PACIFIC \leftrightarrow ALASKA \leftrightarrow HAWAII \leftrightarrow
 (back to the beginning)

NOTE:

If an incorrect time is displayed by the Plug & Play function, you may be receiving the clock setting data of a PBS channel from an adjacent time zone or from an incorrect PBS channel from a cable TV system. If you selected "AUTO" for the host channel in step 4, be sure to select the correct time zone manually.

7 Complete the Semiauto Clock Set.

Press **SET UP** to return to normal screen.

IMPORTANT:

Turn off the unit after performing Semiauto Clock. "AUTO" will appear on the front display panel while the clock is being set. The current clock time will appear automatically when the clock setting is complete.

AUTO DAYLIGHT SAVING TIME

This function enables automatic adjustment of the unit's clock at the start and end of Daylight Saving Time.

With Auto DST activated, —

- on the first Sunday of April at 2:00 AM, the clock is adjusted to 3:00 AM.
- on the last Sunday of October at 2:00 AM, the clock is adjusted to 1:00 AM.

NOTE:

Timer recording may not function correctly at the time Daylight Saving Time is adjusted.

Manual Clock Set

1 Access the Main Menu screen.

Press **SET UP**.

2 Access the "CLOCK SET" screen.

- Press \triangleleft / \triangleright to select "INITIAL SET UP", then press **ENTER**.
- Press \triangleleft / \triangleright to select "CLOCK SET", then press **ENTER**.

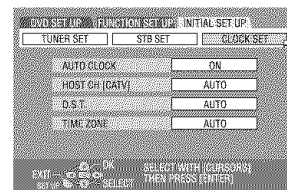

3 Set "AUTO CLOCK" to "OFF".

- Press Δ / ∇ to move the arrow to "AUTO CLOCK", then press **ENTER**.
- Press Δ / ∇ to select "OFF", then press **ENTER**.

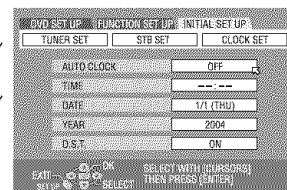

4 Set time, date and year.

- Press Δ / ∇ to move the arrow to "TIME", then press **ENTER**.
- Press Δ / ∇ until the desired time appears, then press **ENTER**. Set the date and year in the same way.
 - Holding Δ / ∇ changes the time in 30-minute intervals, or changes the date in 15-day intervals.

5 Select D.S.T. mode.

- Press Δ / ∇ to move the arrow to "D.S.T.", then press **ENTER**.
- Press Δ / ∇ to select the desired setting, then press **ENTER**.

ON: Adjustment will be made by the built-in clock itself.

OFF: Select when Daylight Saving Time does not apply to you.

6 Start clock.

Press **SET UP** and normal screen appears.

Tuner Set

- Turn on the unit.
- Turn on the TV and select the AV mode.
- Slide the TV/CABLE/DBS/DVD switch to DVD.

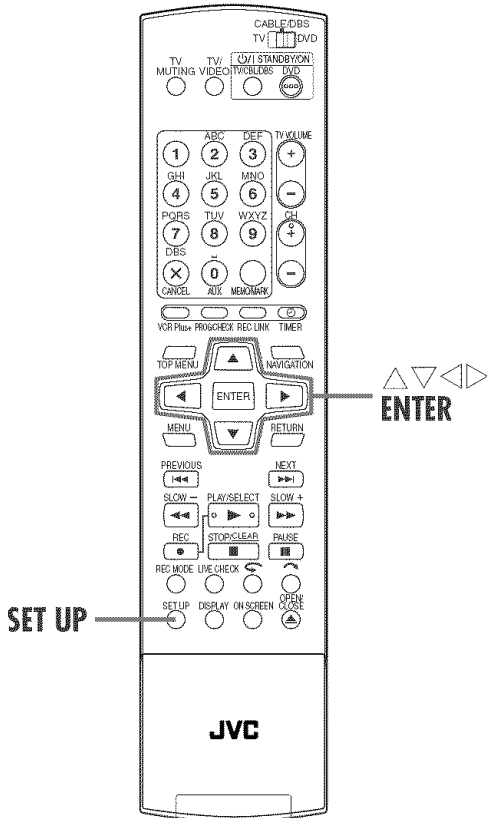

Auto Channel Set

Perform Auto Channel Set only if channels have not been set correctly by the Plug&Play setting.

1 Access the Main Menu screen.

Press **SET UP**.

2 Access the "TUNER SET" screen.

- 1 Press \triangle ∇ to select "INITIAL SET UP", then press **ENTER**.
- 2 Press \triangle ∇ to select "TUNER SET", then press **ENTER**.

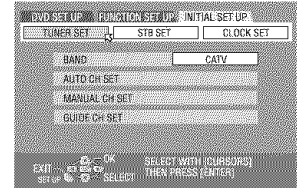

3 Perform Auto Channel Set.

Press \triangle ∇ to move the arrow to "AUTO CH SET", then press **ENTER**. You can automatically set the receivable channels in your area in the order of their frequencies.

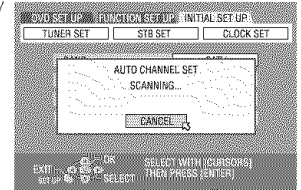

- When Auto Channel Set is complete, "SCAN COMPLETED" appears on the TV screen.
- If the scan was unsuccessful, "SCAN COMPLETED-NO SIGNAL-" appears on screen. Check the connections and start again.

4 Complete the setting.

Press **SET UP**.

INFORMATION

The unit selects the correct band (TV or CATV) automatically during Auto Channel Set. The selected band will be displayed on the right side of "BAND" on the Tuner Set screen.

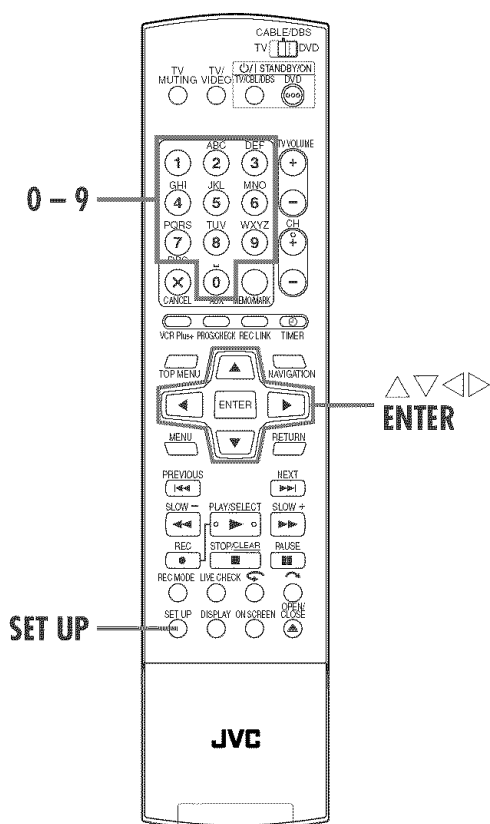

Manual Channel Set

You can add the channels you want or delete the channels you do not want manually.

1 Access the Main Menu screen.

Press **SET UP**.

2 Access the "TUNER SET" screen.

- 1 Press \triangle ∇ to select "INITIAL SET UP", then press **ENTER**.
- 2 Press \triangle ∇ to select "TUNER SET", then press **ENTER**.

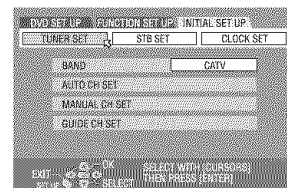

3 Access the Manual Channel Set screen.

Press \triangle ∇ to move the arrow to "MANUAL CH SET", then press **ENTER**.

4 Add or skip the desired channels.

To add channels

- 1 Press \triangle ∇ to move the arrow to "CH", then press **ENTER**.
- 2 Press the **number keys** to select a channel number you want to add, then press **ENTER**.
- 3 Press \triangle ∇ to move the arrow to "ADD/SKIP", then press **ENTER**.
- 4 Press \triangle ∇ to select "ADD", then press **ENTER**.
- 5 Repeat [2] - [4] to add other channels.

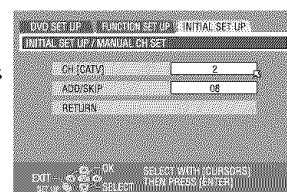

To skip channels

- 1 Press \triangle ∇ to move the arrow to "CH", then press **ENTER**.
- 2 Press the **number keys** to select a channel number you want to skip, then press **ENTER**.
- 3 Press \triangle ∇ to move the arrow to "ADD/SKIP", then press **ENTER**.
- 4 Press \triangle ∇ to select "SKIP", then press **ENTER**.
- 5 Repeat [2] - [4] to skip other channels.

5 Complete the setting.

Press **SET UP**.

Monitor Set

You can select the monitor type depending on the TV used when you play back DVD VIDEO discs recorded for wide-screen TVs.

- Turn on the unit.
- Turn on the TV and select the AV mode.
- Slide the **TV/CABLE/DBS/DVD** switch to **DVD**.

1 Access the Main Menu screen.

Press **SET UP**.

2 Access the "VIDEO IN/OUT" screen.

- 1 Press \triangle \triangleright to move the arrow to "FUNCTION SET UP", then press **ENTER**.
- 2 Press \triangle \triangleright to move the arrow to "VIDEO IN/OUT", then press **ENTER**.

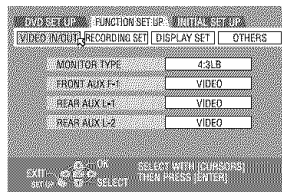

3 Select the desired option.

- 1 Press \triangle ∇ to select "MONITOR TYPE", then press **ENTER**.
- 2 Press \triangle ∇ to select the desired option, then press **ENTER**.

4 Complete the setting.

Press **SET UP**.

(The **boldface** settings in the table below indicate the settings at your purchase.)

MONITOR TYPE

4:3LB (Letter Box conversion):

Select this when the aspect ratio of your TV is 4:3 (conventional TV). While viewing a wide screen picture, the black bars appear on the top and the bottom of the screen.

4:3PS (Pan&Scan):

Select this when the aspect ratio of your TV is 4:3 (conventional TV). While viewing a wide screen picture, the black bars do not appear; however, the left and right edges of the pictures will not be shown on the screen.

16:9 AUTO (Wide television conversion):

Select this when the aspect ratio of your TV is 16:9 (wide TV).

16:9 FIX (Wide television conversion):

Select this when the aspect ratio of your TV is fixed to 16:9 (wide TV). The unit automatically adjusts the screen width of the output signal correctly when playing back a picture whose aspect ratio is 4:3.

Pan&Scan/Letter Box

In general, DVD VIDEO disc are produced for a wide-screen TV with 16:9 aspect ratio.

Material with this ratio will not fit to a TV with 4:3 aspect ratio. There are two styles to display the image, "Pan&Scan" (PS) and "Letter Box" (LB).

Pan&Scan

The right and left side of the image are cut off. The image fills the screen.

- The picture will be shown in the "4:3LB" mode depending on the disc even if the "4:3PS" mode is selected.

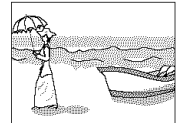

Letter Box

Black bands appear at the top and bottom of the image. The image itself appears in 16:9 aspect ratio.

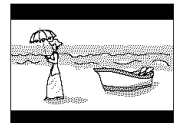

Cable Box Control Setting

Place the cable box on top of the unit. Attach the unit's Controller to the top of the unit with the Controller's transmitter pointed towards the cable box's remote sensor.

ATTENTION:

The Controller can also control a DBS receiver. If both a cable box and a DBS receiver are used, position the Controller so its signal reaches the remote sensors of both the cable box and DBS receiver.

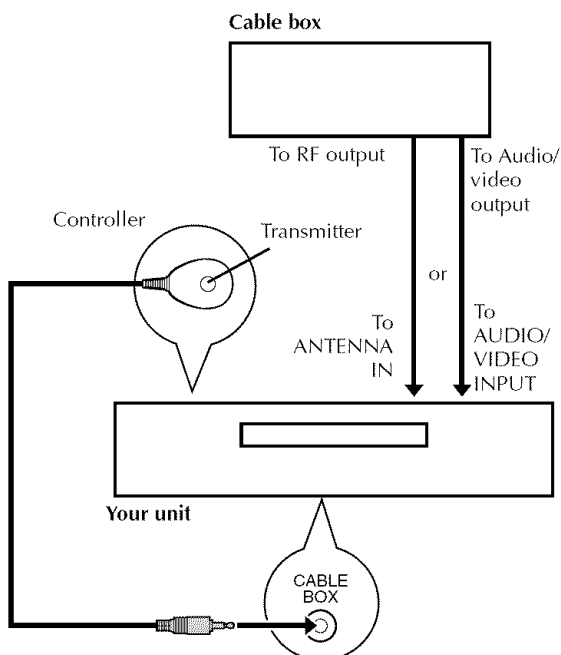
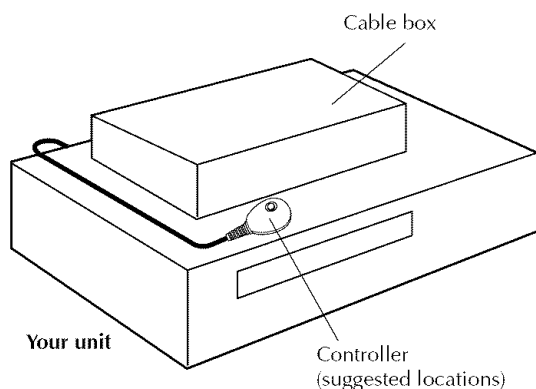

The following procedure is required if you receive your TV channels through a cable box (descrambler). The Controller allows the unit to automatically switch the cable box channel during timer recording. The Controller is effective for recording broadcasts that have been programmed using "VCR Plus+™ Timer Programming" (☞ pg. 60) or "Manual Timer Programming" (☞ pg. 64).

Installing Controller

1 Install a Controller.

Place a Controller so that the path between its transmitter and the cable box's remote sensor is unobstructed.

2 Attach the Controller.

Fix securely using the adhesive strip attached on the back of the Controller.

3 Make connections.

If your cable box does not have audio/video output connectors

Connect the RF output connector on the cable box to the ANTENNA IN connector on the rear of your unit.

If your cable box has audio/video output connectors

Connect an audio/video cable between the AUDIO/VIDEO INPUT connectors on the rear of the unit and the audio/video output connectors on the cable box.

NOTE:

When connecting your cable box, refer to its instruction manual.

4 Connect the Controller to unit.

Connect the Controller to the CABLE BOX connector on the rear panel.

How to control the cable box

This unit has two separate methods to control your cable box.

- The unit's wireless Remote can control your cable box. This eliminates the need for a separate cable box's Remote.
- The unit's Controller can also control your cable box. This allows the unit to change your cable box's channel number during timer recording.

Each method must be set up separately. To set up the unit's Remote, refer to page 93. To set up the Controller, go to page 30.

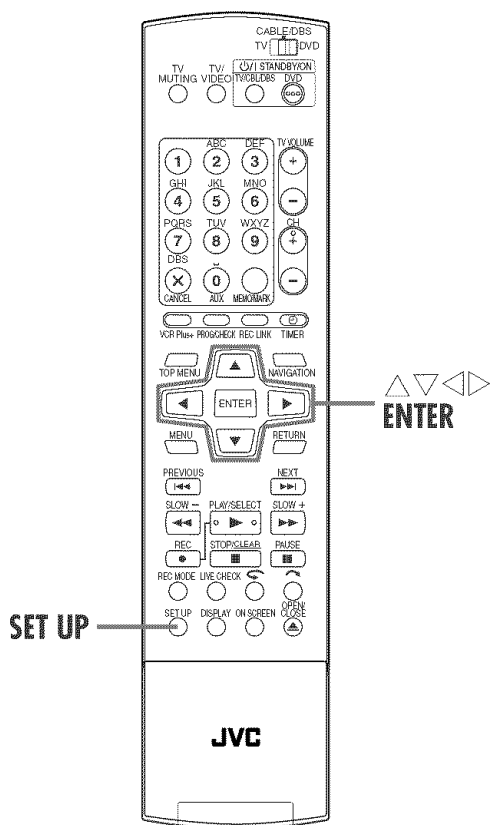

Setting cable box's brand and channel

After installation, set the cable box's brand and channel correctly; otherwise, the Controller cannot work correctly.

- Turn on the unit.
- Turn on the TV and select the AV mode.
- Slide the TV/CABLE/DBS/DVD switch to DVD.

1 Turn on the cable box.

Turn on the cable box's power.

2 Access the Main Menu screen.

Press **SET UP**.

3 Access the "CABLE BOX SET" screen.

- 1 Press $\triangleleft \triangleright$ to move the arrow to "INITIAL SET UP", then press **ENTER**.
- 2 Press $\triangleleft \triangleright$ to move the arrow to "STB SET", then press **ENTER**.
- 3 Press $\triangle \nabla$ to move the arrow to "CABLE BOX SET", then press **ENTER**.

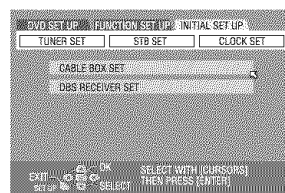

4 Select the cable box's channel.

Your selection depends on how the cable box is connected to your unit.

- 1 Press $\triangle \nabla$ to move the arrow to "CABLE BOX OUTPUT CH", then press **ENTER**.
- 2 If the cable box is connected to your unit's **ANTENNA IN** connector on the rear panel, press $\triangle \nabla$ to select the channel number representing the cable box's output (CH2 – CH9), then press **ENTER**.
If the cable box is connected to your unit's **AUDIO/VIDEO INPUT** connectors on the rear panel, press $\triangle \nabla$ to select "L-1" or "L-2", then press **ENTER**.
If you do not use a cable box, press $\triangle \nabla$ to select "OFF", then press **ENTER**.

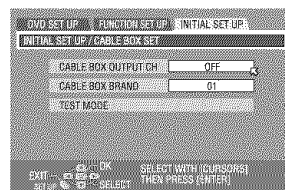

5 Enter the cable box's brand.

- 1 Press \triangle/∇ to move the arrow to "CABLE BOX BRAND", then press **ENTER**.
- 2 Press \triangle/∇ to select the brand code from the following list, then press **ENTER**.
- 3 Press \triangle/∇ to move the arrow to "TEST MODE", then press **ENTER**.

If the cable box's channel changes to 9, setting is complete.

Press **ENTER** and "CABLE BOX CONTROL IS ON" appears on the screen for about 5 seconds, then the screen in step 3 appears.

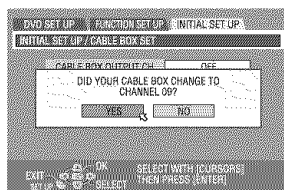

If the cable box's channel does not change to 9;

- 1 Press \triangle/∇ to move the arrow to "NO", then press **ENTER**.
- 2 Repeat step 5 until the cable box's channel changes to 9 by entering another code.
- 3 If the channel does not change after going through all the code numbers listed for your model of cable box, then try all the other numbers.

NOTES:

- The Controller may not work with all types of cable box.
- If your cable box does not respond to any code between 1 and 28, you cannot use the Controller to change cable box channels. In this case, make sure to leave the cable box turned on and tuned to the proper channel before the scheduled start time of timer recording. Contact your cable company about the possibility of exchanging your current cable box with the one compatible with your unit.
- The unit can only change the cable box channel through the Controller during timer recording.
- If your cable box cannot be operated with a Remote (because it has no remote sensor), you cannot use the Controller to change its channels. Make sure to leave the cable box turned on and tuned to the proper channel before the scheduled start time of timer recording.
- If the unit's memory backup expires because of a power failure, set the cable box output channel and brand again.
- **For customers in U.S.A.:** If you are unable to set the Controller, contact JVC toll free at 1-800-252-5722.

BRAND NAME	CODE
ARCHER	1, 5, 17
CABLETENNA	1, 17
CABLEVIEW	15, 16, 17, 21, 25
CITIZEN	15, 16, 17, 21, 25
CURTIS	2, 8
DIAMOND	1, 17
GC BRAND	15, 16, 17, 21, 25
GEMINI	15
GENERAL INSTRUMENTS	1, 4, 6, 11, 12, 15, 28
HAMLIN	10, 18, 23
JASCO	15
JERROLD	1, 4, 6, 11, 12, 15, 28
NOVAVISION	2, 8
OAK	7, 20
PANASONIC	13, 14
PULSER	15, 16, 17, 21, 25
RCA	13, 14
REGAL	10, 18, 23
REMBRANDT	1, 16, 17
SAMSUNG	5, 16, 24
SCIENTIFIC ATLANTA	2, 8
SIGMA	7, 20
SL MARX	5, 16, 17, 24, 25
SPRUCER	13, 14
STARGATE	5, 15, 16, 17, 21, 24, 25
TELEVIEW	5, 16, 24
TOCOM	1, 4, 16
UNIKA	1, 17
UNIVERSAL	16, 17, 25
VIDEOWAY	3, 9, 22
ZENITH	3, 9, 22

DBS Receiver Control Setting

Place the DBS (Direct Broadcast Satellite) receiver on top of the unit. Attach the unit's Controller to the top of the unit with the Controller's transmitter pointed towards the DBS receiver's remote sensor.

ATTENTION:

The Controller can also control a cable box. If both a DBS receiver and a cable box are used, position the Controller so its signal reaches the remote sensors of both the DBS receiver and cable box.

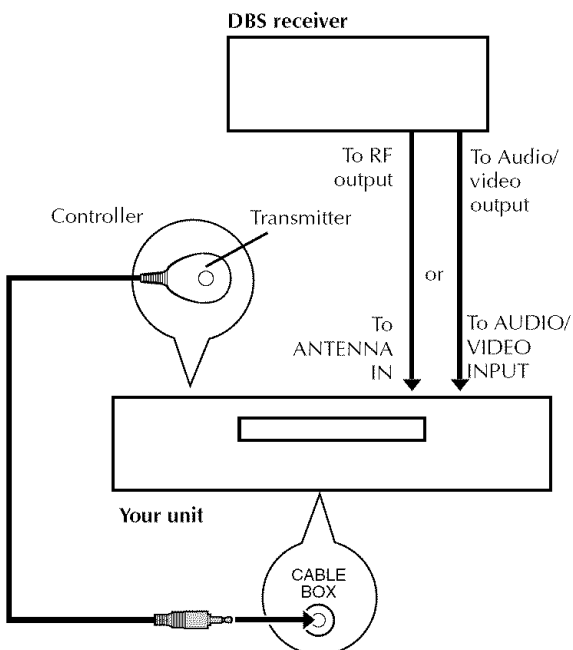
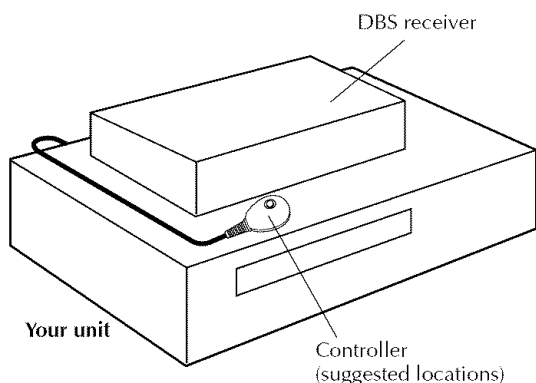

The following procedure is required if you receive satellite channels through a DBS (Direct Broadcast Satellite) receiver. The Controller allows the unit to automatically switch the DBS receiver's channel during timer recording.

NOTES:

- The unit can automatically change the DBS receiver channels using the Controller when the unit has been programmed using "Manual Timer Programming" (pg. 64). Because satellite programming does not use PlusCode, the Controller cannot change the DBS receiver channels during "VCR Plus+ Timer Programming" (pg. 60).
- If a cable box is also used, it is recommended that you connect the DBS receiver to your unit's audio/video input connectors and the cable box to your unit's antenna input connector.

Installing Controller

1 Install a Controller.

Place a Controller so that the path between its transmitter and the DBS receiver's remote sensor is unobstructed.

2 Attach the Controller.

Fix securely using the adhesive strip attached on the back of the Controller.

3 Make connections.

If your DBS receiver does not have audio/video output connectors

Connect the RF output connector on the DBS receiver to the ANTENNA IN connector on the rear of your unit.

If your DBS receiver has audio/video output connectors

Connect an audio/video cable between the AUDIO/VIDEO INPUT connectors on the rear of the unit and the audio/video output connectors on the DBS receiver.

NOTE:

When connecting your DBS receiver, refer to its instruction manual.

4 Connect the Controller to unit.

Connect the Controller to the CABLE BOX connector on the rear panel.

How to control the DBS receiver

This unit has two separate methods to control your DBS receiver.

- The unit's wireless Remote can control your DBS receiver. This eliminates the need for a separate DBS receiver's Remote.
- The unit's Controller can also control your DBS receiver. This allows the unit to change your DBS receiver's channel number during timer recording.

Each method must be set up separately. To set up the unit's Remote, refer to page 94. To set up the Controller, go to page 33.

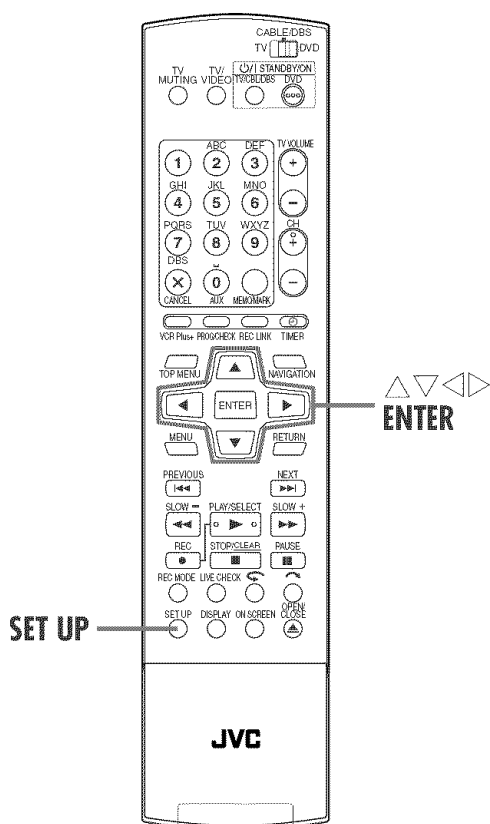

Setting DBS receiver's brand and channel

After installation, set the DBS receiver's brand and channel correctly; otherwise, the Controller cannot work correctly.

- Turn on the unit.
- Turn on the TV and select the AV mode.
- Slide the TV/CABLE/DBS/DVD switch to DVD.

1 Turn on the DBS receiver.

Turn on the DBS receiver's power.

2 Access the Main Menu screen.

Press SET UP.

3 Access the "DBS RECEIVER SET" screen.

- 1 Press $\triangleleft \triangleright$ to move the arrow to "INITIAL SET UP", then press ENTER.
- 2 Press $\triangleleft \triangleright$ to move the arrow to "STB SET", then press ENTER.
- 3 Press $\triangle \nabla$ to move the arrow to "DBS RECEIVER SET", then press ENTER.

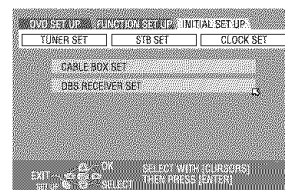

4 Select the DBS receiver's channel.

Your selection depends on how the DBS receiver is connected to your unit.

- 1 Press $\triangle \nabla$ to move the arrow to "DBS RECEIVER OUTPUT CH", then press ENTER.
- 2 If the DBS receiver is connected to your unit's **ANTENNA IN** connector on the rear panel, press $\triangle \nabla$ to select the channel number representing the DBS receiver's output (CH3 or CH4), then press ENTER.

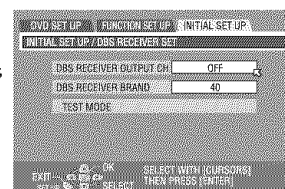

If the DBS receiver is connected to your unit's **AUDIO/VIDEO INPUT** connectors on the rear panel, press $\triangle \nabla$ to select "L-1" or "L-2", then press ENTER. If you do not use a DBS receiver, press $\triangle \nabla$ to select "OFF", then press ENTER.

5 Enter the DBS receiver's brand.

- 1 Press \triangle / ∇ to move the arrow to "DBS RECEIVER BRAND", then press **ENTER**.
- 2 Press \triangle / ∇ to select the brand code from the following list, then press **ENTER**.
- 3 Press \triangle / ∇ to move the arrow to "TEST MODE", then press **ENTER**. The program currently received through the DBS receiver appears.

BRAND NAME	CODE
JVC (DISH Network)	51
ECHOSTAR (DISH Network)	51
SONY (DSS)	41
RCA (DSS)	40

If the DBS receiver's channel changes to the channel listed below for your brand, setting is complete.

JVC → 100
 ECHOSTAR → 100
 SONY → 205
 RCA → 205

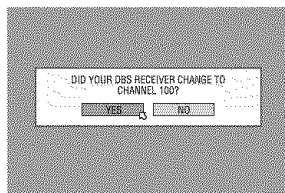

Press **ENTER** and "DBS RECEIVER CONTROL IS ON" appears on the screen for about 5 seconds, then press **ENTER**. The screen in step 3 appears.

If the DBS receiver's channel does not change as shown above;

- 1 Press \triangle / ∇ to move the arrow to "NO", then press **ENTER**.
- 2 Repeat step 5.

NOTES:

- The Controller may not work with all types of DBS receiver.
- If your DBS receiver does not respond to the code, you cannot use the Controller to change satellite channels. In this case, make sure to leave the DBS receiver turned on and tuned to the proper channel before the scheduled start time of timer recording.
- The unit can only change the satellite channel through the Controller during timer recording.
- If your DBS receiver cannot be operated with a Remote (because it has no remote sensor), you cannot use the Controller to change its channels. Make sure to leave the DBS receiver turned on and tuned to the proper channel before the scheduled start time of timer recording.
- If the unit's memory backup expires because of a power failure, set the cable box output channel and brand again.
- **For customers in U.S.A.:** If you are unable to set the Controller, contact JVC toll free at 1-800-252-5722.

Basic Playback



- Turn on the unit.
- Turn on the TV and select the AV mode.
- Slide the TV/CABLE/DBS/DVD switch to DVD.

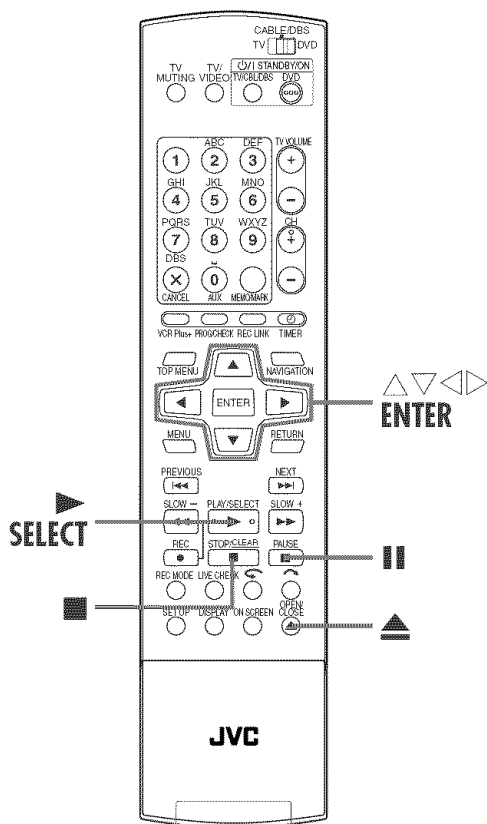
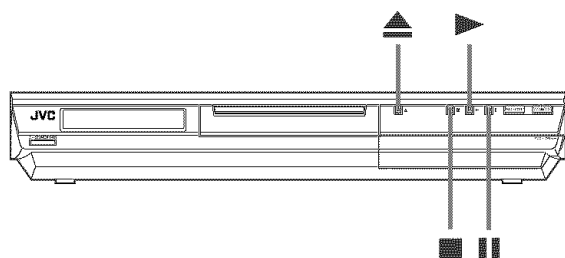

ATTENTION:

- It takes approximately 30 seconds to read a disc depending on the type and condition of the disc since this unit is multi-disc compatible (DVD-RAM, DVD-RW, DVD-R). It may even take several minutes when a disc is dirty, scratched or warped.
- It may take a few seconds to start playback. This is not a malfunction.
- Forward/reverse high-speed search and other operations cannot be performed while playback is stopped.

To play back an MP3/JPEG disc, see "Playback with MP3/JPEG Navigation" (pg. 84).

1 Load a disc.

- 1 Press **▲** to open the disc tray.
 - 2 Place the disc on the disc tray.
 - 3 Press **▲** to close the disc tray.
- For details, refer to "Placing a Disc" (pg. 11).
 - Pressing **▶** also closes the disc tray.
 - Playback begins automatically if an auto-playback DVD disc is loaded.

2 Start playback.

Press **▶**.

- If you load a DVD disc whose region code does not match the unit, "REGION CODE ERROR" appears on the TV screen. For details, refer to "Region Number" (pg. 8).
- With Video CD/SVCD discs with PBC control or some DVD discs, the menu display may appear on the TV screen after starting playback. In this case, select an item which you want to play back from the menu. Otherwise, the playback cannot go forward. Refer to "Locating a desired scene using the menu of a Video CD/SVCD with PBC" (pg. 40) or "Locating a desired scene using the DVD menu" (pg. 36).
- The Library Database DVD Navi also enables you to search and select the desired programs. (pg. 72)

3 Pause playback.

Press **||**.

- To resume normal playback, press **▶**.

4 Stop playback.

Press **■**.

- When a recordable disc is played, playback stops and a program received with the unit's tuner resumes on the TV screen.
- When a playback-only disc is played, playback stops and the still image at the time you press **■** remains on the TV screen. Pressing **■** again resumes a program received with the unit's tuner.
- If **▲** is pressed during playback, playback stops, then the disc tray opens.

NOTE:

When the Library Database DVD Navi screen appears, choose a thumbnail image of the desired program on the TV screen, then press **SELECT** or **ENTER**. (pg. 74)

Playback Features

- Turn on the unit.
- Turn on the TV and select the AV mode.
- Slide the TV/CABLE/DBS/DVD switch to DVD.

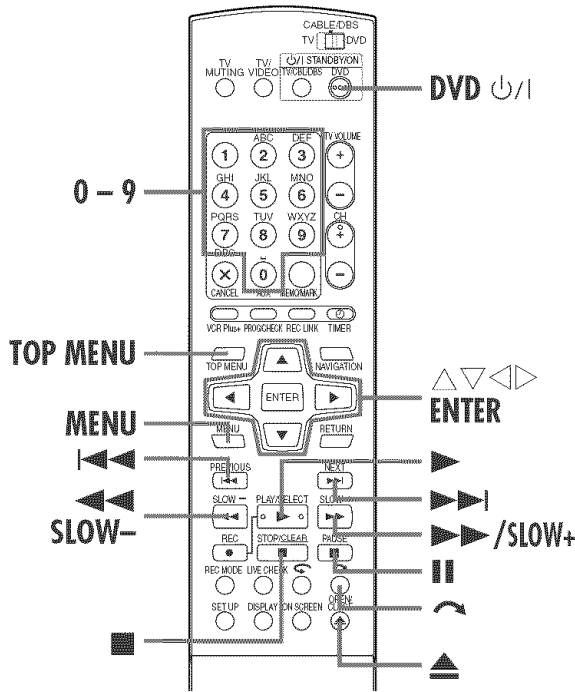

2 Start playback.

Press $\Delta \nabla \triangleleft \triangleright$ to select a desired title, then press **ENTER**.

- It may be possible to select the desired item using the **number keys** depending on the menu display.

NOTE:

When "Ⓞ" appears on the TV screen in step 1, the disc does not have a top menu or disc menu.

Locating the start point of the item or skip the item



Press $\triangleleft \triangleright$ or $\triangleright \triangleright$ during playback.

- Pressing $\triangleright \triangleright$ locates the start point of the item or skips the item for forward direction, then resumes playback.
- Pressing $\triangleleft \triangleleft$ locates the start point of the item or skips the item for reverse direction, then resumes playback.

When a DVD-RAM/RW/R disc is played

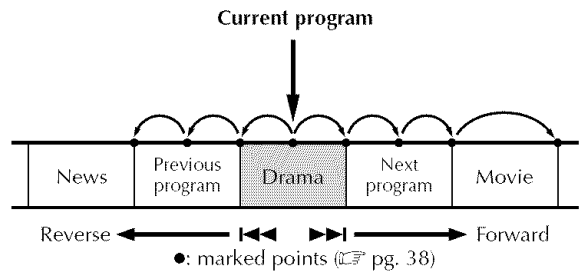

Example:

To locate the beginning of the next item, press $\triangleright \triangleright$ once.
 To locate the beginning of the current item, press $\triangleleft \triangleleft$ once.
 To locate the beginning of the previous item, press $\triangleleft \triangleleft$ three times.

When a DVD VIDEO, Audio CD or Video CD/SVCD disc is played

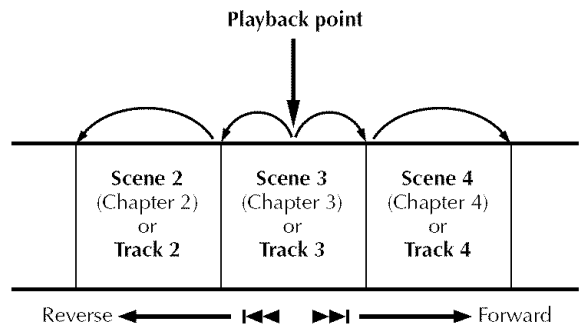

Example:

To locate the beginning of the next item, press $\triangleright \triangleright$ once.
 To locate the beginning of the current item, press $\triangleleft \triangleleft$ once.

Locating a desired scene using the DVD menu



DVD VIDEO discs may have top menu and disc menu.

Top menu

DVD discs generally have their own menus which show the disc contents. These menus contain various items such as titles of a movie, names of songs, or artist information. You can locate a desired scene by using the top menu displayed on the TV screen. Press **TOP MENU** to access the top menu.

Disc menu

Disc menus include playback data (angle menu, subtitle menu, etc.) specific to each title. Press **MENU** to access the disc menu.

1 Access the DVD menu.

Press **TOP MENU** or **MENU**. Example:

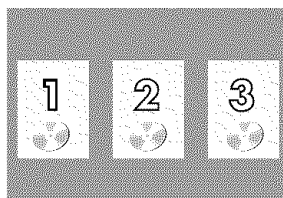

High-Speed Search



During playback, press **▶▶** for forward high-speed search, or **◀◀** for reverse high-speed search.

- Each press of the button increases the search speed for each direction.
- To resume normal playback, press **▶**.

OR

During playback, press and hold **▶▶** for 2 or more seconds for forward high-speed search, or press and hold **◀◀** for 2 or more seconds for reverse high-speed search.

- Releasing the button resumes normal playback.

Still Picture/Frame-By-Frame Playback



1 Pause during playback.

Press **⏸**.

2 Activate frame-by-frame playback.

Press **⏸**.

- Each press of **⏸** advances the still picture frame by frame.

OR

Press **◀▷**.

- Each press of **◀▷** advances/reverses the still picture frame by frame.
- Frame-by-frame playback for reverse direction cannot be performed with Video CD/SVCD discs.
- To resume normal playback, press **▶**.

Slow Motion



While paused, press **SLOW -** or **SLOW +**.

- Each press of **SLOW -** or **SLOW +** increases the slow motion speed for each direction (from 1/16 to 1/2 times the normal speed).
- Slow motion for reverse direction cannot be performed with Video CD/SVCD discs.

OR

Press **◀◀** or **▶▶** for 2 or more seconds.

Skip Search



During playback, press **⏮**.

- Each press initiates an approximately 30-second period of fast-motion playback. Normal playback resumes automatically.

Resume Function



It is possible to memorize the position where you stop playback and resume playback from that position.

- Be sure to set "RESUME" to "ON" or "DISC RESUME". (☞ pg. 100)

1 Memorize a resume point.

Press **■** during playback.

- The unit enters Resume Stop mode and memorizes the position where you have stopped playback as a resume point. (The inside of the disc status indicator on the front display panel blinks in the Resume Stop mode.)
- The unit retains a memory of the resume points of the last 30 discs played back, even though they have been ejected if "RESUME" is set to "DISC RESUME". (☞ pg. 100)
- To clear the resume points: (The inside of the disc status indicator stops blinking and lights.)

When "RESUME" is set to "ON":

- Press **⏻** on the unit or **DVD⏻** on the Remote to turn off the unit.
- Press **▲** to take out the disc.
- Press **■** in stop mode.
- Press **TOP MENU** to display the top menu, then start playback by selecting an item, etc.
- Press **MENU** to display the disc menu, then start playback by selecting an item, etc.

When "RESUME" is set to "DISC RESUME":

- Set "RESUME" to "OFF". (☞ pg. 100)
- Press **■** in stop mode.
- Press **TOP MENU** to display the top menu, then start playback by selecting an item, etc.
- Press **MENU** to display the disc menu, then start playback by selecting an item, etc.

2 Resume playback.

Press **▶** in stop mode. The unit starts playback from the resume point.

NOTES:

- "DISC RESUME" setting works on DVD VIDEO, VCD, SVCD and already finalised DVD-R/DVD-RW (video mode) discs. For other types of discs, the function under "ON" setting will be applied even if "RESUME" is set to "DISC RESUME".
- If you stop the playback of a disc for which a resume point has already been memorized, the memory will be updated with the new resume point.
- After the unit has memorized the resume point for 30 discs, remembering a new resume point will cause the unit to delete the oldest memorized point. Stopping playback of a disc for which a resume point is already stored may change the order in which the points are stored. This may potentially change the order in which points are deleted.
- When the unit memorizes a resume point for a disc, it also remembers audio language, subtitle and angle settings.
- This function may not work for some Video CD or SVCD.
- When "RESUME" is changed to "ON" or "OFF", resume points of the discs memorized with "RESUME" set to "DISC RESUME" will be cleared.
- Resume points are memorized for each side of a double-sided disc.

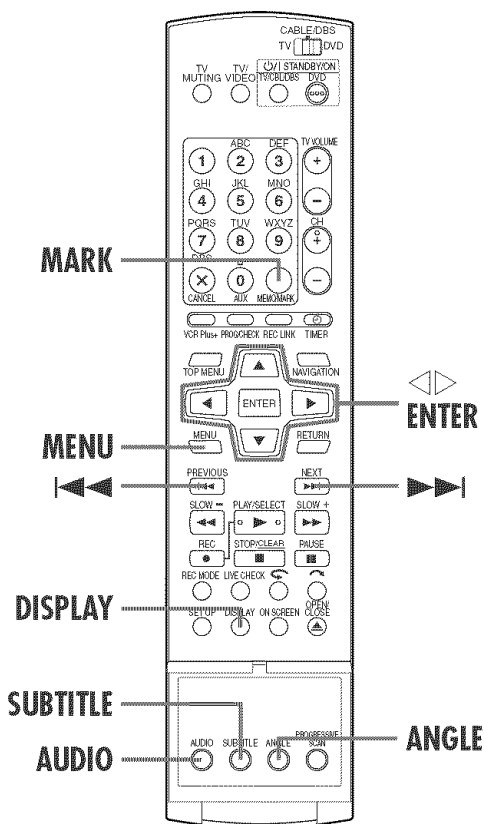

Marking positions to play again later



It is possible to mark positions (up to 999 points) where you want to play back once again later, and start playback from a marked position. Marking onto DVD-RAM/RW/R discs when recording is helpful to locate a start point when you play back the discs later.

1 Mark positions.

During playback, press **MARK** at positions you want to mark.

- "MARK" appears on the TV screen. You can easily locate the marked positions using **◀◀** or **▶▶** when you play back the disc.

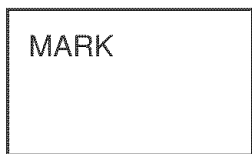

2 Delete the marked positions.

While paused, press **◀◀** or **▶▶** to locate a marked position you want to delete, then press **MARK**.

- Crossed "MARK" appears on the TV screen, and the marked position is deleted.



NOTES:

- When a monaural program or bilingual program changes to a stereo program while recording, a mark signal is automatically recorded.
- When a DVD-R/RW (Video mode) disc is finalized, marked points marked before finalizing will be deleted, and programs will be divided automatically into "chapters" approximately every 5 minutes. (☞ pg. 102, "Finalize a disc")

Checking the time information



You can change the counter display on the front display panel and TV screen to check disc remaining time (only discs before finalizing).

During playback

Each press of **DISPLAY** changes the display as follows:
 Clock time (front display panel only) → Current title elapsed time → Disc remaining time → (back to the beginning)

- Clock time is displayed only when a recordable disc is played.

In stop mode or during playback

- In FR mode, it is possible to set recording time in detail using **◀▶**. (☞ pg. 59, "Free Rate Function")
- It is not possible to switch the recording mode during playback or while recording.

Switching Time Indication



You can check time information of an audio CD and a Video CD/SVCD on the front display panel and the TV screen. Each press of **DISPLAY** changes the time indication as follows:

During playback

Current track elapsed time → Current track remaining time → Total elapsed time → Total remaining time → (back to the beginning)

In stop mode

0:00 → Playback time of track 1 → 0:00 → Total length of a disc → (back to the beginning)

NOTE:

When a PBC-compatible Video CD/SVCD disc is loaded, deactivate the PBC function. (☞ pg. 40)

Angle Selection



You can enjoy a variety of scene angles if a DVD VIDEO disc contains “multi-angle” parts, where the same scene was shot from different angles.

If the disc contains “multi-angle” parts, “” appears on the TV screen at the beginning of the “multi-angle” part.

1 Access Angle display.

Press **ANGLE** during playback.

- The angle selection display appears on the TV screen.

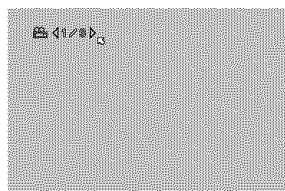

(When 3 scene angles are contained.)

2 Select the angle.

Press **ANGLE** or $\triangleleft \triangleright$ to select your desired angle.

- Each time you press **ANGLE** or $\triangleleft \triangleright$, the angle changes.
- When “” appears on the TV screen, the current scene is not recorded from multiple angles. In addition, some discs prohibit angle selection.
- To clear the angle selection display, press **ENTER**. In addition, the angle selection display disappears automatically if no operation is done for 10 seconds.

Subtitle Selection



Some DVD VIDEO discs contain more than one subtitle language, from among which you can choose the desired subtitle language. “” appears on the TV screen at the beginning of the part where more than one subtitle language are recorded.

1 Access Subtitle display.

Press **SUBTITLE** during playback.

- The subtitle selection display appears on the TV screen.
- Each time you press **SUBTITLE**, the subtitle display is switched on and off.

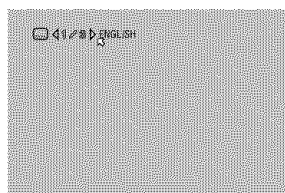

(When 3 subtitle languages are contained.)

2 Select the subtitle language.

Press $\triangleleft \triangleright$ to select your desired language.

- To clear the subtitle selection display, press **ENTER**.

NOTES:

- When “” appears on the TV screen, no subtitle language is recorded.
- When the subtitle language won't be changed with the procedure above, change the subtitle on a disc menu displayed by pressing **MENU**.
- It is not possible to play back SVCD discs with subtitles.

Audio Language/Sound Selection



Some DVD VIDEO discs contain the multiple audio language or sound. You can select the desired audio language or sound. For some Video CD/SVCD discs, you can switch the audio channel to choose Karaoke either with or without the vocal.

1 Access Audio Language/Sound selection display.

Press **AUDIO** during playback.

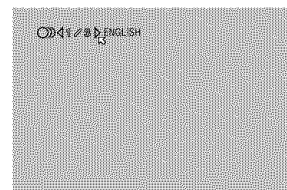

(When 3 audio languages are contained.)

2 Select the audio language/sound.

Each time you press **AUDIO** or $\triangleleft \triangleright$, the audio language/sound changes.

- To clear the Audio Language/Sound selection display, press **ENTER**.

NOTES:

- When “” appears on the TV screen, no audio language is recorded.
- When the audio language won't be changed with the procedure above, change the audio on a disc menu displayed by pressing **MENU**.

Playback Control (PBC) Function

— Locating a desired scene using the menu of a Video CD/SVCD with PBC



Some Video CD/SVCD discs support the PBC function. PBC is an abbreviation of "Play Back Control". A Video CD/SVCD disc recorded with PBC has its own menus, such as a list of the songs on the disc. You can locate a specific scene by using the menu.

1 Access the PBC menu.

In stop mode

Press **▶**.

2 Start playback.

Press the **number keys** to enter the number of the desired scene.

- The unit starts playback of the selected item. "PBC" appears on the front display panel.
- When "NEXT" or "PREVIOUS" appears on the TV screen: Pressing **NEXT** advances to the next page. Pressing **PREVIOUS** returns to the previous page.
- You can return to the menu by pressing **RETURN**.
- The method of the operation is different depending on the disc.

NOTES:

- If you want to playback a PBC-compatible Video CD/SVCD disc without activating the PBC function, start playback in stop mode by using the **number keys**, instead of the **▶** button, to choose the track, then press **ENTER**.
- To activate the PBC function when a PBC-compatible Video CD/SVCD disc is being played back without the PBC function, press **TOP MENU**, or press **■** then press **▶**.

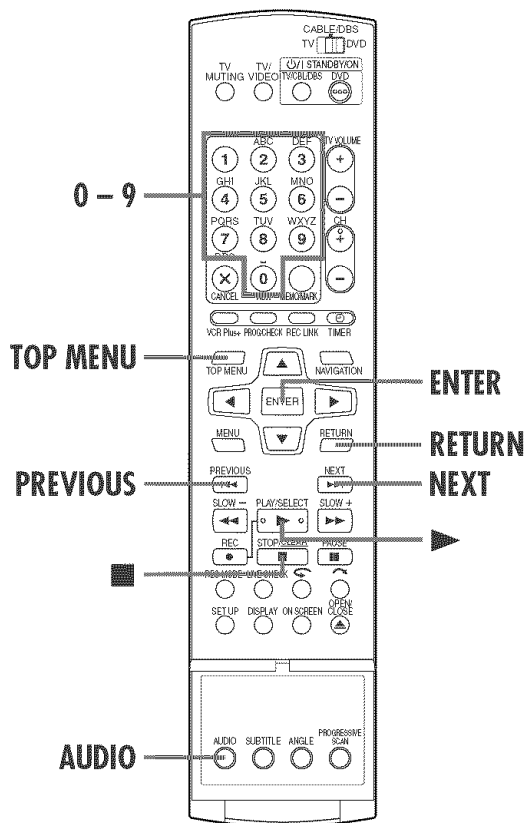

Audio Channel Selection



When playing discs on which you recorded stereo programmes, you can choose the desired audio channel.

- When "SUPERIMPOSE" is set to "AUTO", you can confirm on the TV screen the audio channel you have chosen. (pg. 99)
- Each time you press **AUDIO**, the audio channel changes.

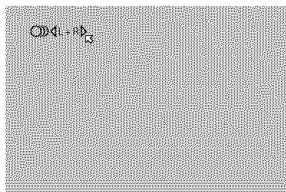

TRACK	USE
On-Screen Display	
	For stereo discs
	For audio of left channel
	For audio of right channel

Live Memory Playback



This unit records pictures onto DVD-RAM discs, instead of video tapes, then plays back the pictures recorded on the discs. This makes it possible to achieve high-speed writing and read-out that has not been possible with conventional VCRs, enabling recording and playback simultaneously.

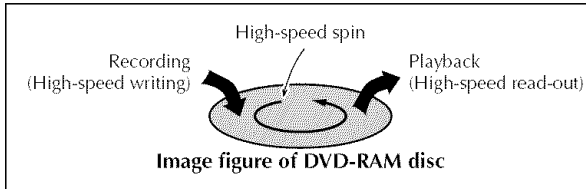

It is called "Live Memory Playback" to start playback of the program being recorded, with a time-lag between a recording point and a playback point, as shown in the figure below.

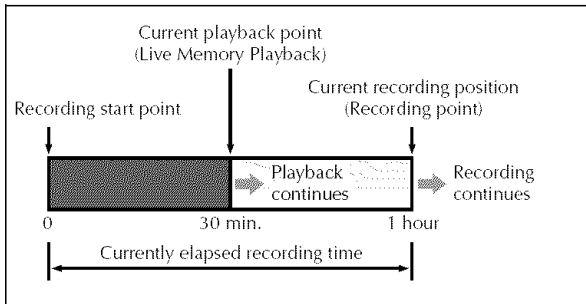

Not only can this unit play back a program previously recorded while recording or timer recording another program, but the unit also allows you to play back from the beginning of a program while continuing to record the same program.

Recording/playback status display

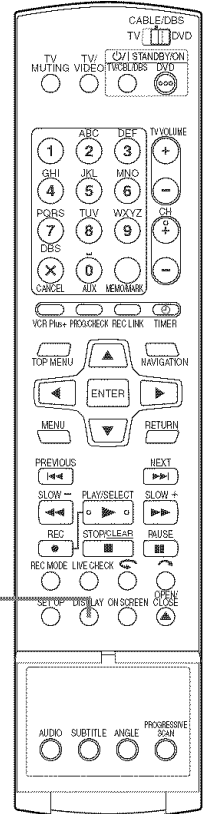

Live Memory Playback status can be checked by pressing **DISPLAY** to display the bar meter on the superimpose display.

Press **DISPLAY**. The current status is superimposed on the TV screen.

Bar meter display



Superimpose display

Overview of Live Memory Playback

You can play back a program you are recording from the beginning while continuing to record or timer record onto a DVD-RAM disc. This is called "Live Memory Playback".

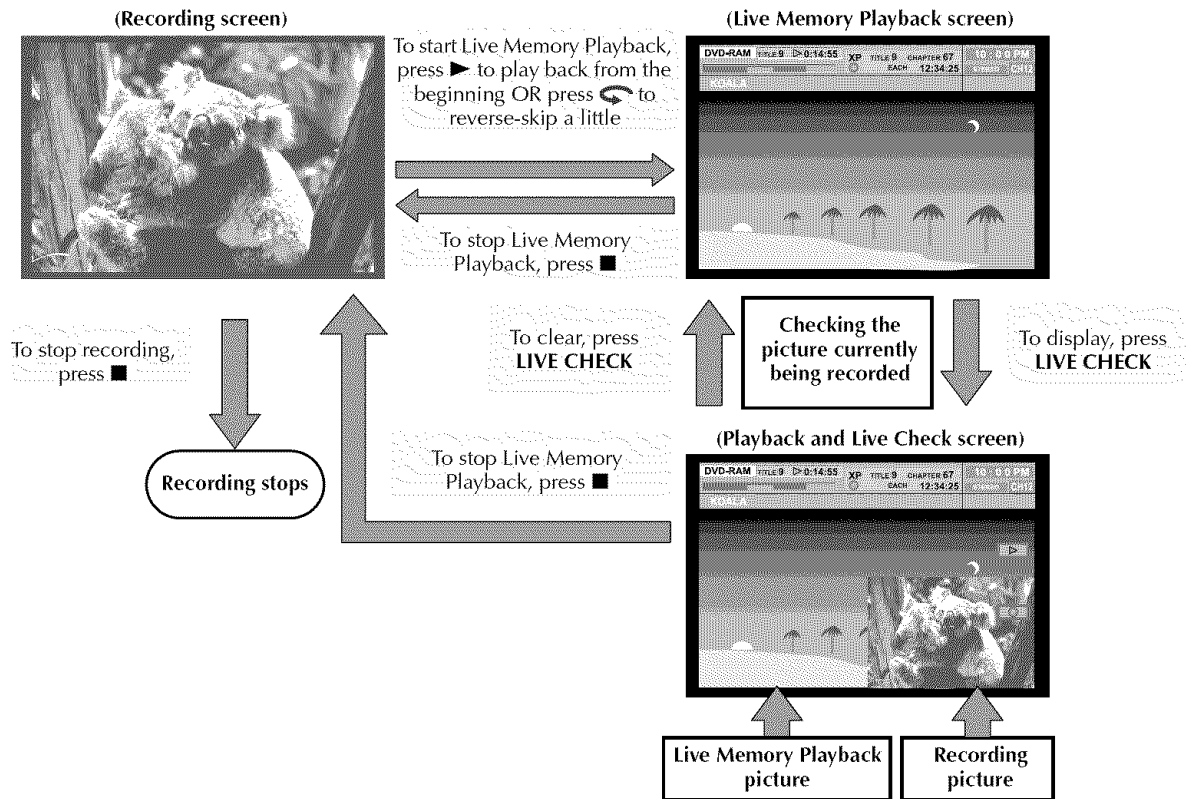

NOTES:

- Live Memory Playback cannot be performed for approximately 30 seconds after recording has started.
- Although high-speed search up to approximately 30 seconds before the current recording point is possible during Live Memory Playback, once the current recording point is reached, the unit resumes normal playback and maintains a delay of approximately 30 seconds so that recording and playback can continue.
- When using Live Memory Playback during timer recording, playback continues even after the end of the recording.
- When using Live Memory Playback during timer recording, playback is automatically stopped just before recording starts, and then recording starts when the time arrives for the next timer-program.
- It is impossible to perform ITR even if you press ● during Live Memory Playback. (☞ pg. 58, "Instant Timer Recording (ITR)") Press ■ to display the program being recorded, then perform ITR settings.
- Playback may be paused for a moment during Live Memory Playback, which does not interfere with recording.
- Live Memory Playback cannot be performed while recording the source from DV input.
- When **LIVE CHECK** is pressed to display the picture currently being recorded, the picture size may not be correct.

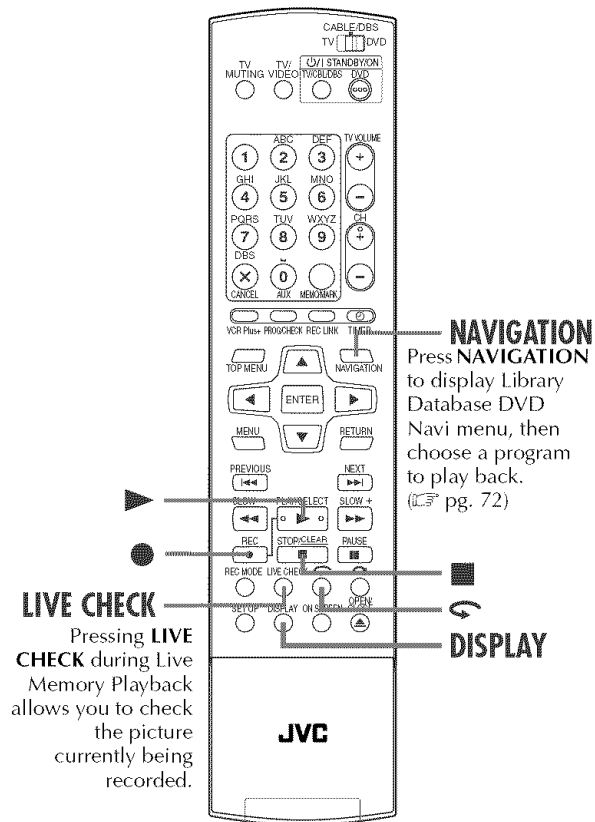

Display during Live Memory Playback

During recording, you can watch at your will what was previously recorded or is currently being recorded. It is possible to perform freely normal playback operations (forward/reverse high-speed search and variable-speed search) within the range of the red or blue bar on the TV screen.

When Live Memory Playback reaches the point of 30 seconds before the current recording point by forward high-speed search or other operations, the unit returns to normal playback.

The superimpose display appears by pressing **ON SCREEN**. (pg. 16)

The Live Check picture is displayed on the bottom right corner by pressing **LIVE CHECK**.

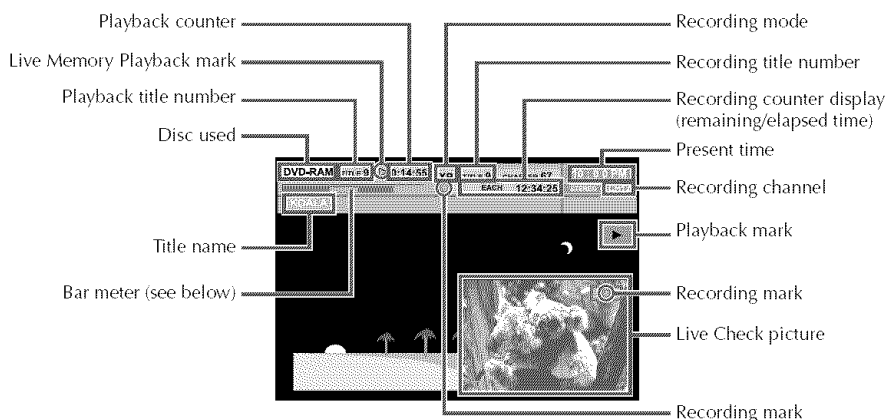





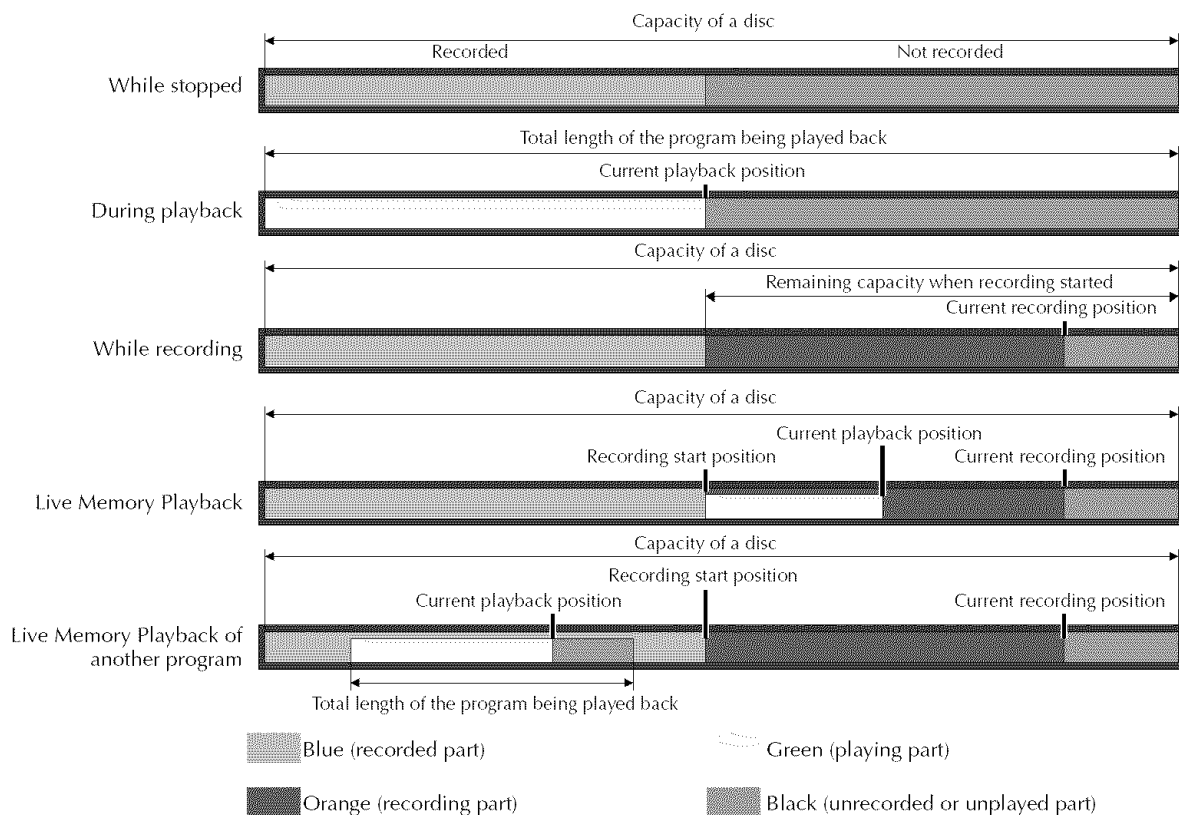



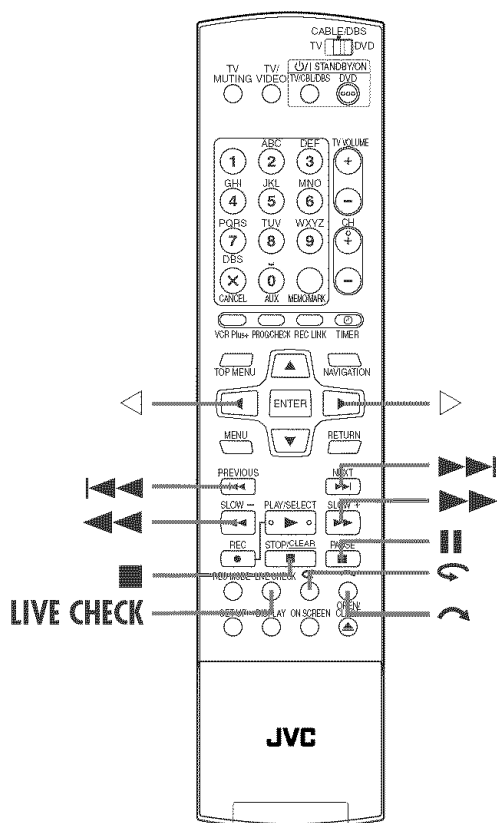

This unit displays the current recording/playback status by the bar meter.

(Example of bar meter display)



Buttons to be used during Live Memory Playback



Available buttons	Functions
	<ul style="list-style-type: none"> Pressing once skips forward to the beginning of the next chapter being played back. Pressing down for 2 or more seconds during playback advances playback at 5 times the normal speed while pressed. Releasing the button resumes normal playback. <p>Available only when paused</p> <ul style="list-style-type: none"> Pressing down for 2 or more seconds advances playback at 1/16 times the normal speed.
	<ul style="list-style-type: none"> Pressing once skips back to the beginning of the chapter being played back. Pressing down for 2 or more seconds during playback reverses playback at 5 times the normal speed while pressed. Releasing the button resumes normal playback. <p>Available only when paused</p> <ul style="list-style-type: none"> Pressing down for 2 or more seconds reverses playback at 1/16 times the normal speed.
	<ul style="list-style-type: none"> Each press of the button during playback advances the playback speed in 4 steps for forward direction. <p>Available only when paused</p> <ul style="list-style-type: none"> Pressing once advances playback by 1/16 times the normal speed. Each press of the button during forward 1/16 times slow-motion advances slow-motion by 1/16 times, 1/4 times and 1/2 times the normal speed.
	<ul style="list-style-type: none"> Each press of the button during playback advances the playback speed in 5 steps for reverse direction. <p>Available only when paused</p> <ul style="list-style-type: none"> Pressing once reverses playback by 1/16 times the normal speed. Each press of the button during reverse 1/16 times slow-motion reverses slow-motion by 1/16 times, 1/4 times and 1/2 times the normal speed.
	<p>Pressing once pauses playback (still picture playback). Pressing repeatedly advances the still picture frame by frame.</p>
	<p>Available only when paused</p> <ul style="list-style-type: none"> Advances/reverses the still picture frame by frame.
	<p>Stops Live Memory Playback to return to the screen being recorded. Then a resume point is stored. Pressing ■ again stops recording.</p>
	<p>Pressing once skips forward for approximately 30 seconds and resumes playback. Pressing repeatedly skips forward continuously as many times as pressed. It is useful when skipping over unwanted sections.</p>
	<p>Pressing once skips back for approximately 7 seconds and resumes playback. Pressing repeatedly skips back continuously as many times as pressed. It is useful when watching sports programs, etc.</p>
<p>LIVE CHECK</p>	<p>Pressing once displays the picture currently being recorded and the one being played back simultaneously. Pressing successively clears the Live Check window and displays only the picture currently being played back. You can check, for example, if the program you are recording has already finished.</p>

- Turn on the unit.
- Turn on the TV and select the AV mode.
- Slide the TV/CABLE/DBS/DVD switch to DVD.

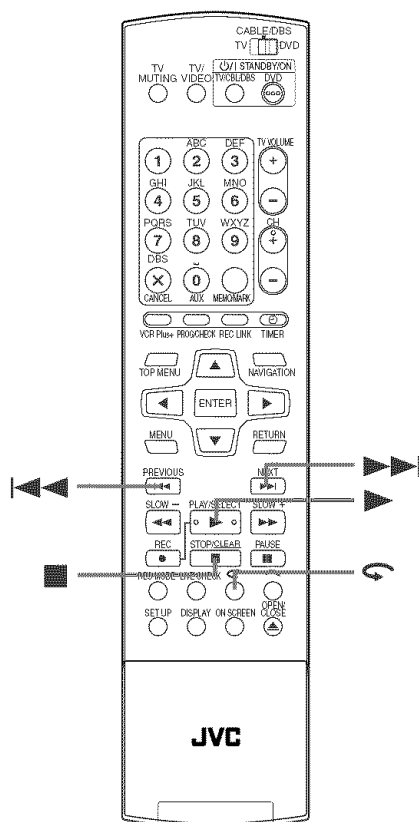

To play back from the beginning of the program while recording

You can play back a program you are recording from the beginning while continuing to record or timer record onto a DVD-RAM disc.

1 Start Live Memory Playback.

Press ►.

- Playback starts from the beginning of the program being recorded.
- Pressing ◀◀/▶▶ allows you to locate the desired scenes.

To move back the playback position slightly while recording (One Touch Replay function)

You can move back the playback position while continuing to record or timer record onto a DVD-RAM disc.

1 Start One Touch Replay function.

Press ↶.

- Each press skips back for approximately 7 seconds and resumes playback.
- Pressing while paused skips back for approximately 7 seconds and resumes pause.

To watch a program previously recorded while recording

You can play back a program you recorded previously while recording.

1 Start Live Memory Playback.

Press ► while recording to establish Live Memory Playback mode.

2 Locate the beginning of the desired program.

Press ◀◀ or ▶▶.

NOTE:

To stop playback, press ■. The program being recorded is displayed.

Using Play Set Up Menu



Play Set Up Menu allows you to control various playback functions. Some of the functions operated on Navigation Menu can be controlled on Set Up Menu.

Before using Play Set Up Menu

Be sure to clear Library Database DVD Navi screen by pressing **NAVIGATION**.

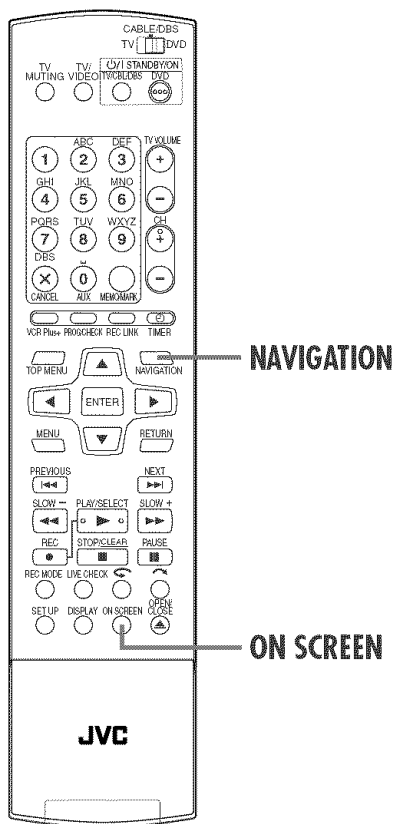

How to Access Play Set Up Menu

Press **ON SCREEN** twice whenever a disc is loaded.

Contents of Play Set Up Menu during playback

DVD VIDEO

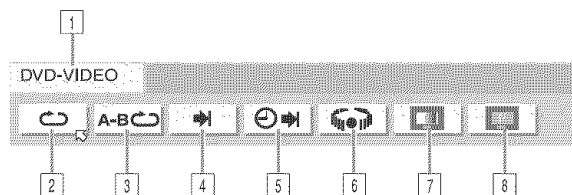

Video CD/SVCD

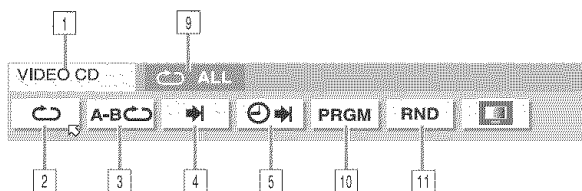

JPEG disc

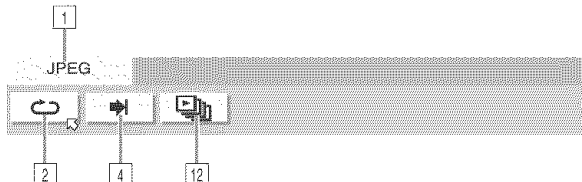

- 1 Disc type.
- 2 Select this for Repeat Playback. (☞ pg. 48)
- 3 Select this for A-B repeat Playback. (☞ pg. 49)
- 4 Select this for search function. (☞ pg. 49)
- 5 Select this for time search function. (☞ pg. 50)
- 6 Select this to switch Simulated Surround Effect function. (☞ pg. 50)
- 7 Select this for Picture Control function. (☞ pg. 51)
- 8 Select this to switch picture source type. (☞ pg. 51)
- 9 Current status area for the selected item.
- 10 Select this for Program Playback. (☞ pg. 52)
- 11 Select this for Random Playback. (☞ pg. 52)
- 12 Select this to control the switching interval of the slide show. (☞ pg. 52)

NOTE:

Although examples of Play Set Up Menu are provided here only for 3 types of discs, Play Set Up Menu will be displayed for whichever disc indicated in the left column.

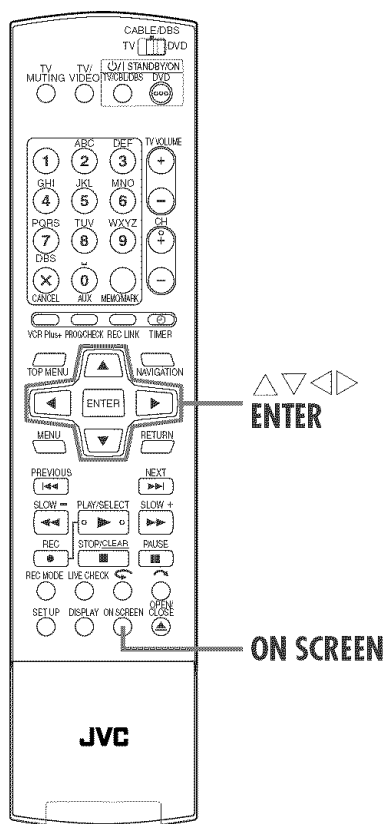

Basic operation on Play Set Up Menu

Example: When selecting Picture Control function of DVD

During playback or while stopped

1 Access Play Set Up Menu.

Press **ON SCREEN** twice.

- The item currently selected is highlighted and pointed by .

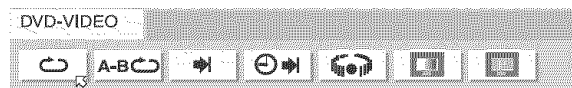

2 Select the menu item.

Press   to select "A-B", then press **ENTER**.

- The pop-up window appears under the selected item.

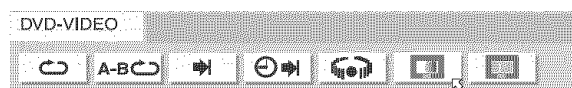

3 Select the option.

Press   to select the desired option, then press **ENTER**.

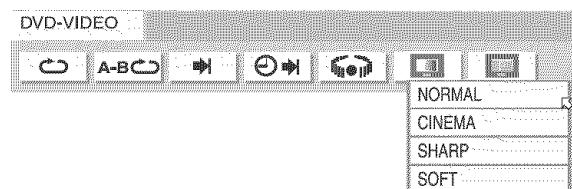

To clear Play Set Up Menu

Press **ON SCREEN**.

NOTE:

See the corresponding pages for details on each menu item.

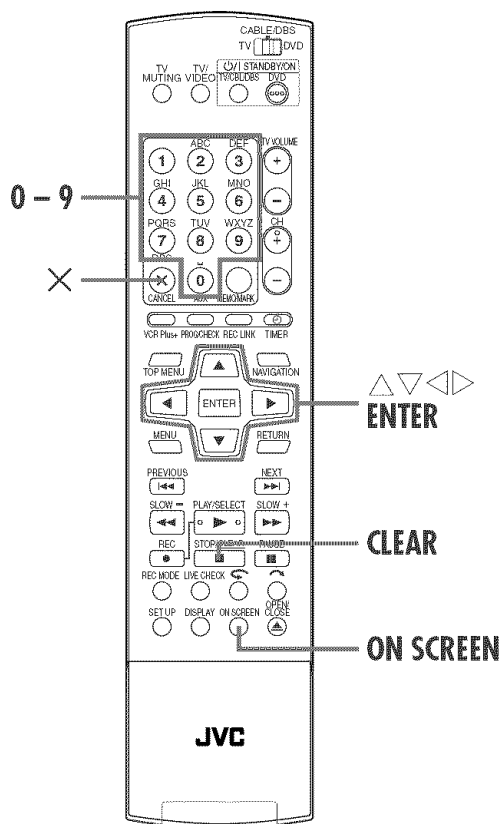

Repeat Playback



You can repeat playback as you like according to the type of disc.

1 Access Play Set Up Menu.

Press **ON SCREEN** twice.

2 Select the menu item.

Press \triangle ∇ to select "⏮", then press **ENTER**.

- The pop-up window appears under the selected item.



3 Select the repeat mode.

Press \triangle ∇ repeatedly to select the desired Repeat mode, then press **ENTER**.

DVD-RAM/RW/R

OFF:	Repeat playback is not performed.
ALL REPEAT:	The whole disc is played back repeatedly.
TITLE REPEAT:	The current title is played back repeatedly.

DVD VIDEO

OFF:	Repeat playback is not performed.
TITLE REPEAT:	The current title is played back repeatedly.
CHAPTER REPEAT:	The current chapter is played back repeatedly.

Audio CD/Video CD/SVCD/JPEG/MP3

OFF:	Repeat playback is not performed.
ALL REPEAT:	The whole disc is played back repeatedly.
TRACK REPEAT*:	The current track is played back repeatedly.

* "TRACK REPEAT" cannot be selected for JPEG discs.

To clear Play Set Up Menu

Press **ON SCREEN**.

To cancel Repeat Playback

Repeat the above procedure from step 1, select "OFF" in step 3, then press **ENTER**.

NOTES:

- Repeat Playback is not possible for a Video CD/SVCD with PBC function.
- Repeat Playback may not work properly depending on the type of the disc being used.

A-B Repeat Playback



You can repeat the desired part.

During playback

1 Access Play Set Up Menu.

Press **ON SCREEN** twice.

2 Select the menu item.

Press $\triangleleft \triangleright$ to select “A-B \curvearrowright ”.

3 Locate the start point.

Press **ENTER** at the beginning of the desired part you want to repeat (point A).

- The elapsed playing time of the point A appears

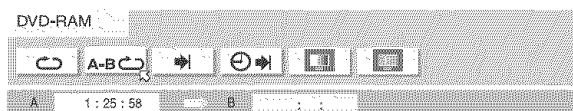

4 Locate the end point and start A-B Repeat Playback.

Press **ENTER** at the end of the desired part you want to repeat (point B).

- The elapsed playing time of the point B appears.
- The selected part of the disc (between point A and B) is played repeatedly.

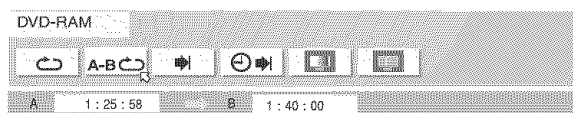

To clear Play Set Up Menu

Press **ON SCREEN**.

To cancel A-B Repeat Playback

Press $\triangleleft \triangleright$ to select “A-B \curvearrowright ”, then press **ENTER**.

NOTES:

- A-B Repeat Playback may not work properly depending on the type of disc being used.
- The subtitles recorded around the A-B point may not appear.
- When the end of the item is reached before the end point is set, Play Set Up Menu disappears from the TV screen. In such a case, repeat the procedure from step 1.
- The point B must be set at least 3 seconds after the point A.
- When playing back a DVD, A-B Repeat Playback is possible only within the same title.
- “A-B \curvearrowright ” cannot be selected during Program and Random Playback.
- “A-B \curvearrowright ” cannot be selected while stopped.

Locating the beginning of a desired selection



You can locate the beginning of a title, chapter, group or track.

During playback or while stopped

1 Access Play Set Up Menu.

Press **ON SCREEN** twice.

2 Select the menu item.

Press $\triangleleft \triangleright$ to select “ \blacktriangleright ”, then press **ENTER**.

3 Select the desired item.

For DVD-RAM/RW/R, DVD VIDEO

“TITLE SEARCH” or “CHAPTER SEARCH” is selectable. (“TITLE SEARCH” only is selectable while stopped.)

For JPEG, MP3

“GROUP SEARCH” or “TRACK SEARCH” is selectable.

For Video CD/SVCD, Audio CD

“TRACK” is selectable.

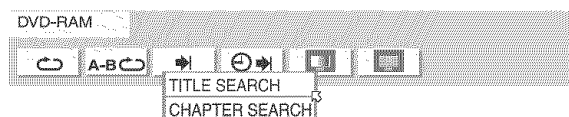

Press $\triangle \nabla$ to select the desired item, then press **ENTER**.

- Skip this step for Video CD/SVCD and Audio CD.

4 Specify the number of the selected item.

Press the **number keys** (1–9, 0) to enter the desired item number, then press **ENTER**.

- Playback starts from the selected section.

Examples:

To select track 5, press the **number key “5”**.

To select track 15, press the **number key “1”** and “5”.

To select track 25, press **number key “2”**, then “5”.

If you have specified a wrong selection

Press **X** or **CLEAR** to clear the wrong number, then enter the correct one before you press **ENTER** in this step.

To clear Play Set Up Menu

Press **ON SCREEN**.

NOTES:

- When “ \odot ” is displayed on the TV screen in step 4, the chapter you have selected is not contained in the disc, or chapter search does not work on the disc.
- Before you press **ENTER**, playback may start automatically when you enter the section’s number depending on the disc.
- This function is not possible for a Video CD/SVCD with PBC function.

Time Search



You can play back a disc from the desired point by specifying the elapsed playing time from the beginning of a title (DVD-RAM, DVD-R, DVD-RW and DVD VIDEO) or a disc (Video CD/SVCD and Audio CD).

1 Access Play Set Up Menu.

Press **ON SCREEN** twice.

2 Select the menu item.

Press $\triangleleft \triangleright$ to select “⏮⏪”, then press **ENTER**.

- The pop-up window appears under the selected item.



3 Enter the time.

Use **number keys** (1–9, 0) to enter the time, then press **ENTER**.

- Playback starts from the specified time.

Example:

To play back from a point 12 (minutes): 50 (seconds) elapsed.

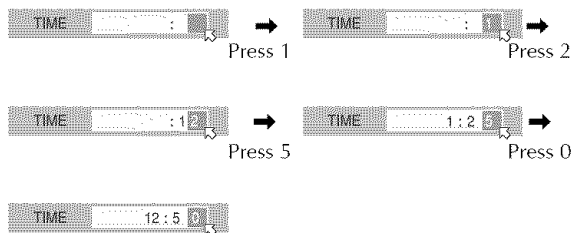

If you have specified a wrong selection,

Press **X** (for the last entered number) or **■** (for whole numbers) to clear the wrong number, then enter the correct one(s) before you press **ENTER** in this step.

To clear Play Set Up Menu

Press **ON SCREEN**.

NOTES:

- When “⊙” is displayed on the TV screen in step 3, you have selected a point that exceeds the recording time of the disc.
- Some DVD VIDEO discs do not contain time information, and it is not possible to use the Time Search function. In such cases, “⊙” is displayed on the TV screen as well.
- This function is not possible for a Video CD/SVCD with PBC function.

Simulated Surround Effect



It is possible to get a simulated surround effect from your stereo system. You can enjoy the virtual surround sound with your 2-channel stereo system.

1 Access Play Set Up Menu.

Press **ON SCREEN** twice.

2 Select the menu item.

Press $\triangleleft \triangleright$ to select “⦿”, then press **ENTER**.

- Above the selected item, “3D-ON” appears and Simulated Surround Effect is activated.
- Each time you press **ENTER**, “3D-ON” appears and disappears alternately.

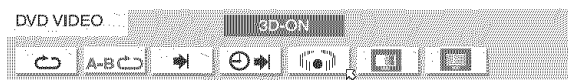

To cancel the simulated surround effect

Press **ENTER** to clear “3D-ON” from the screen.

NOTES:

- The simulated surround effect works correctly only when playing back a title recorded in multichannels.
- Simulated Surround Effect does not affect the DVD VIDEO bitstream signal from the DIGITAL OUT connector.
- When Simulated Surround Effect is activated, the settings of “ANALOG AUDIO OUT” and “D. RANGE CONTROL” are disabled. (pg. 97)

Adjusting the picture quality



You can obtain optimal picture quality by selecting an appropriate picture mode.

1 Access Play Set Up Menu.

Press **ON SCREEN** twice.

2 Select the menu item.

Press $\triangleleft \triangleright$ to select “”, then press **ENTER**.

- The pop-up window appears under the selected item.



3 Select the desired option.

Press $\triangle \nabla$ to select the desired option, then press **ENTER**.

NORMAL:	Normally select this option.
CINEMA:	Suitable for a movie disc, etc.
SHARP:	Clearer, sharper-edged picture when viewing images with lots of flat, same-coloured surfaces such as cartoons.
SOFT:	Select this option when too much noise appears.

Setting the progressive mode



You can obtain optimal picture quality by selecting whether the content on the disc is processed by field (video source) or by frame (film source).

1 Access Play Set Up Menu.

Press **ON SCREEN** twice.

2 Select the menu item.

Press $\triangleleft \triangleright$ to select “”, then press **ENTER**.

- The pop-up window appears under the selected item.



3 Select the desired option.

Press $\triangle \nabla$ to select the desired option, then press **ENTER**.

AUTO 1:	Used to play a disc containing both video and film source materials. This system recognizes the source type (video or film) of the current disc according to the disc information. Normally select this option.
AUTO 2:	Almost the same as the “AUTO 1”, but the processing of the scenes with movement is different. Select “AUTO 1” or “AUTO 2” to your preference.
FILM:	Suitable for playing back a progressive scanned film source disc.
VIDEO:	Suitable for playing back a video source disc. The outlines on the played back pictures will be soft.

Program Playback



You can play back up to 30 tracks in the desired order.

While stopped

1 Access Play Set Up Menu.

Press **ON SCREEN** twice.

2 Select the menu item.

Press \triangleleft \triangleright to select "PRGM", then press **ENTER**.

- The program table appears under Play Set Up Menu.



3 Select the tracks in the desired order.

Use **number keys** (1–9, 0) to enter the track numbers.

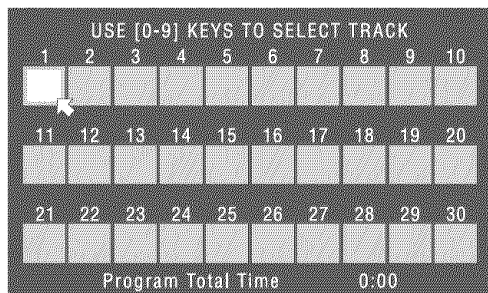

Examples:

- To select track 5, press the **number key "5"** and **ENTER**.
- To select track 15, press the **number key "1"** and **"5"**.
- To select track 25, press the **number key "2"** and **"5"**.

If you have specified a wrong selection

Press **X**. The last selection is erased.

Or press **■**. The whole selection is erased.

4 Start playback.

Press **▶**. Playback starts in the programmed order.

- When all of the programmed tracks have been played back, Program Playback stops, but the programmed information remains.
- To add tracks to the end of the program, perform steps 1 through 3.
- During Program Playback, pressing **▶▶** skips to the next selection of the program. Pressing **◀◀** returns to the beginning of the current selection.

To clear Play Set Up Menu and the contents of the program from the screen

Press **ON SCREEN**.

To cancel Program Playback

Press \triangleleft \triangleright to select "PRGM", then press **ENTER**.

NOTE:

Program Playback is not possible depending on the type of disc.

Random Playback



You can play back all the tracks on the disc in random order.

While stopped

1 Access Play Set Up Menu.

Press **ON SCREEN** twice.

2 Select the menu item.

Press \triangleleft \triangleright to select "RND", then press **ENTER**.

- Playback starts in random order.

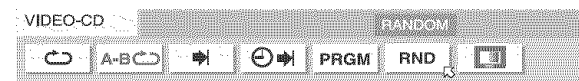

To clear Play Set Up Menu

Press **ON SCREEN**.

To cancel Random Playback

Perform steps 1 and 2.

NOTE:

The same track will not be played back more than once during Random Playback.

Select the switching interval of the slide show



You can control the switching interval of the slide show.

1 Access Play Set Up Menu.

Press **ON SCREEN** twice.

2 Select the menu item.

Press \triangleleft \triangleright to select "10 SEC.", then press **ENTER**.

- The pop-up window appears under the selected item.



3 Select the desired option.

Press \triangle ∇ to select the desired option, then press **ENTER**.

- Each time you press \triangle ∇ , the interval changes as follows:
5 SEC. \leftrightarrow 10 SEC. \leftrightarrow 15 SEC. \leftrightarrow 20 SEC. \leftrightarrow 25 SEC. \leftrightarrow 30 SEC. \leftrightarrow (Back to the beginning)

Parental Lock



This function restricts playback of DVD VIDEO discs which contain violent (and other) scenes according to the level set by the user. For example, if a movie which includes violent scenes supports the parental lock feature, such scenes which you do not want to let children view can be cut or replaced by other scenes.

- Turn on the unit.
- Turn on the TV and select the AV mode.
- Slide the TV/CABLE/DBS/DVD switch to DVD.

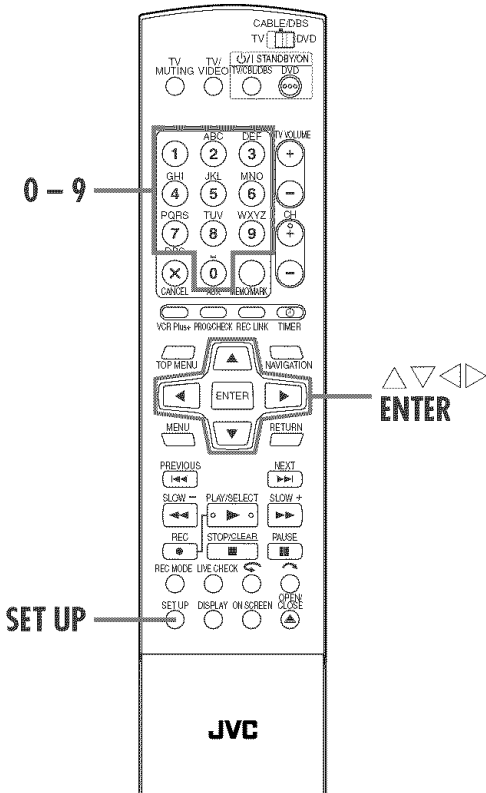

To set Parental Lock for the first time

While stopped

1 Access the "DVD SET UP" screen.

- 1 Press **SET UP**.
- 2 Press $\triangleleft \triangleright$ to select "DVD SET UP", then press **ENTER**.

2 Access the "PARENTAL LOCK" screen.

- 1 Press $\triangleleft \triangleright$ to select "UTILITY", then press **ENTER**.
- 2 Press $\triangle \nabla$ to select "PARENTAL LOCK", then press **ENTER**.

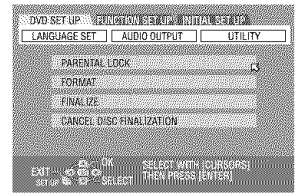

3 Select the desired level.

- 1 Press $\triangle \nabla$ repeatedly to select "PARENTAL LEVEL", then press **ENTER**.
 - 2 Press $\triangle \nabla$ repeatedly to select the desired level, then press **ENTER**.
- The smaller the value of level is, the more restrictive the Parental Lock level becomes.
 - Select "NONE" to cancel the restriction.

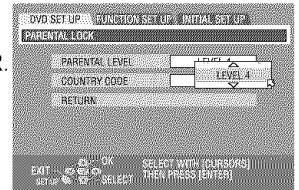

4 Enter your password.

- Press the **number keys** to enter your desired four-digit number, then press **ENTER**.
- If you made a mistake, enter a correct number again.

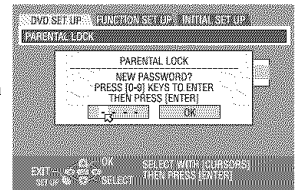

5 Select your country code.

- 1 Press $\triangle \nabla$ repeatedly to select "COUNTRY CODE", then press **ENTER**.
 - 2 Press $\triangle \nabla$ repeatedly to select your country code, then press **ENTER**.
- If you do not need to change your country code, jump to 7.
 - See "Country/Area Code List for Parental Lock" (pg. 55).

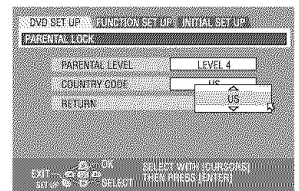

6 Enter your password.

Press the **number keys** to enter the same password as in step 4 above, then press **ENTER**.

7 Complete the setting.

- Press **SET UP** twice.
- The normal screen resumes.

NOTE:

Remember your password, or make a note of it.

To change the settings

You can change the Parental lock settings later.

Perform steps **1** to **2** of "To set Parental Lock for the first time" on page 53 to access the "PARENTAL LOCK" screen before continuing.

1 Change the level.

- 1 Press \triangle / ∇ repeatedly to select "PARENTAL LEVEL", then press **ENTER**.
- 2 Press \triangle / ∇ repeatedly to select the desired level, then press **ENTER**.

2 Change the country code.

- 1 Press \triangle / ∇ repeatedly to select "COUNTRY CODE", then press **ENTER**.
 - 2 Press \triangle / ∇ repeatedly to select your country code, then press **ENTER**.
- See "Country/Area Code List for Parental Lock" (📖 pg. 55).

3 Enter your password.

Press the **number keys** to enter the same password as in step **2** of "To set Parental Lock for the first time", then press **ENTER**.

4 Complete the setting.

Press **SET UP** twice.

- The normal screen resumes.

NOTE:

If you forget your password, enter "8888" in step **3**.

To temporarily release Parental Lock

When you set the parental lock level strictly, some discs may not be played back at all. When you insert such a disc and try to play it back, the confirmation screen appears on the TV screen, asking you whether you want Parental Lock to be temporarily released or not.

1 Access the password screen.

- 1 Place the disc on the disc tray.
 - If the disc is rated higher than the selected level, the confirmation screen appears.
- 2 Press \triangle / ∇ to select "YES", then press **ENTER**.
 - If you select "NO", you cannot play back that disc.

2 Enter your password.

Press the **number keys** to enter the same password as in step **2** of "To set Parental Lock for the first time", then press **ENTER**.

- When you enter the correct password, the Parental Lock is released and the unit starts playback.
- If you enter a wrong password, "ENTRY ERROR RETRY" appears on the TV screen. Enter the correct password.
- If you have successively entered wrong password three times, "ENTRY ERROR CAN NOT CHANGE PASSWORD" appears on the TV screen. In such a case, press **ENTER**. The disc will stop. Then play the disc again, and try the procedure again from step **1**.

NOTE:

If you forget your password, enter "8888" in step **2**.

Country/Area Code List for Parental Lock

AD	Andorra	ES	Spain
AE	United Arab Emirates	ET	Ethiopia
AF	Afghanistan	FI	Finland
AG	Antigua and Barbuda	FJ	Fiji
AI	Anguilla	FK	Falkland Islands (Malvinas)
AL	Albania	FM	Micronesia (Federated States of)
AM	Armenia	FO	Faroe Islands
AN	Netherlands Antilles	FR	France
AO	Angola	FX	France, Metropolitan
AQ	Antarctica	GA	Gabon
AR	Argentina	GB	United Kingdom
AS	American Samoa	GD	Grenada
AT	Austria	GE	Georgia
AU	Australia	GF	French Guiana
AW	Aruba	GH	Ghana
AZ	Azerbaijan	GI	Gibraltar
BA	Bosnia and Herzegovina	GL	Greenland
BB	Barbados	GM	Gambia
BD	Bangladesh	GN	Guinea
BE	Belgium	GP	Guadeloupe
BF	Burkina Faso	GQ	Equatorial Guinea
BG	Bulgaria	GR	Greece
BH	Bahrain	GS	South Georgia and the South Sandwich Islands
BI	Burundi	GT	Guatemala
BJ	Benin	GU	Guam
BM	Bermuda	GW	Guinea-Bissau
BN	Brunei Darussalam	GY	Guyana
BO	Bolivia	HK	Hong Kong
BR	Brazil	HM	Heard Island and McDonald Islands
BS	Bahamas	HN	Honduras
BT	Bhutan	HR	Croatia
BV	Bouvet Island	HT	Haiti
BW	Botswana	HU	Hungary
BY	Belarus	ID	Indonesia
BZ	Belize	IE	Ireland
CA	Canada	IL	Israel
CC	Cocos (Keeling) Islands	IN	India
CF	Central African Republic	IO	British Indian Ocean Territory
CG	Congo	IQ	Iraq
CH	Switzerland	IR	Iran (Islamic Republic of)
CI	Côte d'Ivoire	IS	Iceland
CK	Cook Islands	IT	Italy
CL	Chile	JM	Jamaica
CM	Cameroon	JO	Jordan
CN	China	JP	Japan
CO	Colombia	KE	Kenya
CR	Costa Rica	KG	Kyrgyzstan
CU	Cuba	KH	Cambodia
CV	Cape Verde	KI	Kiribati
CX	Christmas Island	KM	Comoros
CY	Cyprus	KN	Saint Kitts and Nevis
CZ	Czech Republic	KP	Korea, Democratic People's Republic of
DE	Germany	KR	Korea, Republic of
DJ	Djibouti	KW	Kuwait
DK	Denmark	KY	Cayman Islands
DM	Dominica	KZ	Kazakhstan
DO	Dominican Republic	LA	Lao People's Democratic Republic
DZ	Algeria	LB	Lebanon
EC	Ecuador		
EE	Estonia		
EG	Egypt		
EH	Western Sahara		
ER	Eritrea		

LC	Saint Lucia	SA	Saudi Arabia
LI	Liechtenstein	SB	Solomon Islands
LK	Sri Lanka	SC	Seychelles
LR	Liberia	SD	Sudan
LS	Lesotho	SE	Sweden
LT	Lithuania	SG	Singapore
LU	Luxembourg	SH	Saint Helena
LV	Latvia	SI	Slovenia
LY	Libyan Arab Jamahiriya	SJ	Svalbard and Jan Mayen
MA	Morocco	SK	Slovakia
MC	Monaco	SL	Sierra Leone
MD	Moldova, Republic of	SM	San Marino
MG	Madagascar	SN	Senegal
MH	Marshall Islands	SO	Somalia
ML	Mali	SR	Suriname
MM	Myanmar	ST	Sao Tome and Principe
MN	Mongolia	SV	El Salvador
MO	Macau	SY	Syrian Arab Republic
MP	Northern Mariana Islands	SZ	Swaziland
MQ	Martinique	TC	Turks and Caicos Islands
MR	Mauritania	TD	Chad
MS	Montserrat	TF	French Southern Territories
MT	Malta	TG	Togo
MU	Mauritius	TH	Thailand
MV	Maldives	TJ	Tajikistan
MW	Malawi	TK	Tokelau
MX	Mexico	TM	Turkmenistan
MY	Malaysia	TN	Tunisia
MZ	Mozambique	TO	Tonga
NA	Namibia	TP	East Timor
NC	New Caledonia	TR	Turkey
NE	Niger	TT	Trinidad and Tobago
NF	Norfolk Island	TV	Tuvalu
NG	Nigeria	TW	Taiwan, Province of China
NI	Nicaragua	TZ	Tanzania, United Republic of
NL	Netherlands	UA	Ukraine
NO	Norway	UG	Uganda
NP	Nepal	UM	United States Minor Outlying Islands
NR	Nauru	US	United States
NU	Niue	UY	Uruguay
NZ	New Zealand	UZ	Uzbekistan
OM	Oman	VA	Vatican City State (Holy See)
PA	Panama	VC	Saint Vincent and the Grenadines
PE	Peru	VE	Venezuela
PF	French Polynesia	VG	Virgin Islands (British)
PG	Papua New Guinea	VI	Virgin Islands (U.S.)
PH	Philippines	VN	Viet Nam
PK	Pakistan	VU	Vanuatu
PL	Poland	WF	Wallis and Futuna Islands
PM	Saint Pierre and Miquelon	WS	Samoa
PN	Pitcairn	YE	Yemen
PR	Puerto Rico	YT	Mayotte
PT	Portugal	YU	Yugoslavia
PW	Palau	ZA	South Africa
PY	Paraguay	ZM	Zambia
QA	Qatar	ZR	Zaire
RE	Réunion	ZW	Zimbabwe
RO	Romania		
RU	Russian Federation		
RW	Rwanda		

Basic Recording



- Turn on the unit.
- Turn on the TV and select the AV mode.
- Slide the TV/CABLE/DBS/DVD switch to DVD.

ATTENTION:
It is not possible to record programs on a DVD-R disc which has already been finalized.

2 Choose a program.

Press **CH +/-** or the **number keys** to select the channel you wish to record.

3 Set the recording speed.

Press **REC MODE** repeatedly until the desired recording speed appears.

- Each time you press **REC MODE**, the recording speed changes as follows:
XP → SP → LP → EP → FR60–FR360*, FR420, FR480 →
(Back to the beginning)

* The value is selectable from 1 to 6 hours in 5-min. increment by pressing **<D>** repeatedly after selecting "FR60–FR360". To change the value in 30-min. increments, press and hold **<D>**.

- For details on the recording speed, see page 58.

4 Start recording.

Press and hold **●**, then press **▶** on the Remote, or press **●** on the unit.

5 Pause recording.

Press **II**.
• To resume recording, press **▶**.

6 Stop recording.

Press **■**.
It takes about 10 seconds to end the writing session when you stop recording.

NOTES:

- It is recommended to format a DVD-RAM disc before use if you use the disc on this unit for the first time.
- When using a brand-new DVD-RW disc, format the disc either in VR mode or in Video mode. (pg. 101, "Format a DVD-RW disc")
- You can record up to 99 programs and 999 play lists on each disc.
- Some programs can only be recorded one time.
- When recording is started, an index of the first part of recording is automatically recorded (pg. 72, "Library Database DVD Navi"). To record a satellite programs, refer to page 71. To delete the index, refer to page 77.
- Recording sometimes may stop or cannot be performed even if there is enough available capacity remaining on the disc.

Recording Resume Function
If there is a power outage during recording, Instant Timer Recording (ITR) (pg. 58) or timer recording (pg. 60, 64), the recording will resume automatically when power is restored to the unit unless the unit's memory backup has expired.

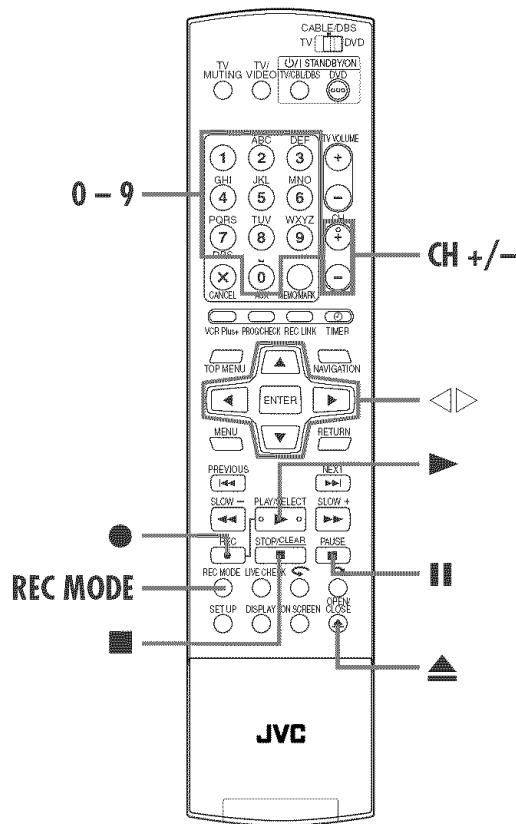
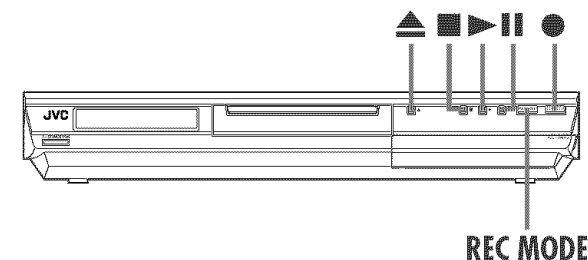

1 Load a disc.

- 1 Press **▲** to open the disc tray.
- 2 Place a recordable disc on the disc tray.
• For details, refer to "Placing a Disc" (pg. 11).
- 3 Press **▲** to close the disc tray.

Recording Features

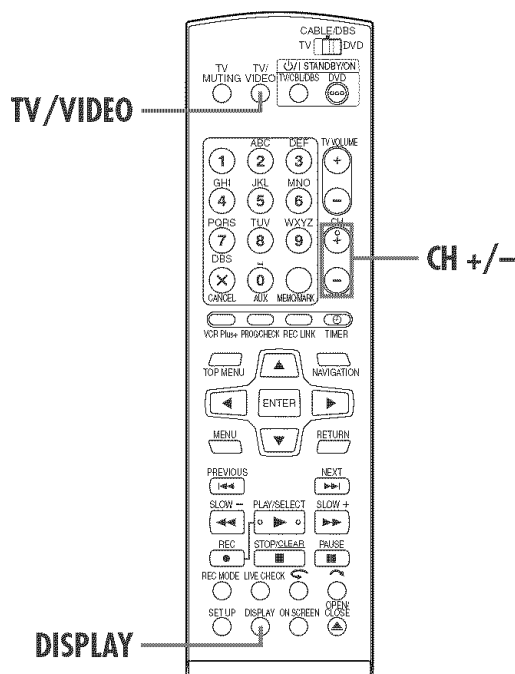
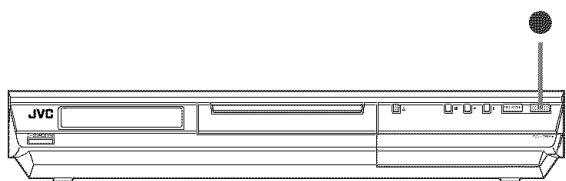

Recording Speed

MPEG2 format is used as recording format. As a guide for picture quality, the "bps" unit is used to represent how much data can be recorded per second. The larger this value is, the better the picture quality becomes but more capacity is required for the recording. Select XP or SP for programs where quick movement occurs, such as sports programs, and LP or EP for talk shows, etc. with relatively less movement.

The recording speeds for a 4.7 GB disc are set as follows:

Recording speed	Recording amount (approx.)	Maximum recording time (approx.)
XP	10 Mbps	1 hour
SP	5 Mbps	2 hours
LP	2 Mbps	4 hours
EP	1.6 Mbps	6 hours
FR60–FR360 (pg. 59)	The amount varies depending on the selected time.	1 – 6 hours
FR420		7 hour
FR480		8 hour

Instant Timer Recording (ITR)

This easy method lets you record for from 30 minutes to 6 hours (selectable in 30-min. increments), and shuts the unit off after recording is finished.

1 Start recording.

Press **●** on the unit.

2 Engage the ITR mode.

Press **●** again. On the front display panel, "0:30" appears.

3 Set the recording duration.

If you want to record for more than 30 minutes, press **●** to extend the time. Each press extends recording time by 30 minutes.

NOTES:

- You can only perform ITR using the **●** button on the unit's front panel.
- It is possible to set the recording duration up to 6 hours, but it is impossible to set exceeding the disc remaining time.

Watch Another Program While Recording on the Unit

While recording is going on, you can watch another program on the TV by using the TV's tuner. It is required that the Remote is set to be able to operate the TV in advance. (pg. 92, "TV Multi-Brand Remote Control")

1 Switch the TV to TV mode.

During recording, press **TV/VIDEO** to select TV mode.

- Video mode is disengaged and the video indicator on the unit is turned off.
- The program received on the TV's tuner is displayed on the TV screen.

2 Switch the Remote to TV control mode.

Slide the **TV/CABLE/DBS/DVD** switch to **TV**.

3 Select the desired channel.

Press **CH +/-** repeatedly.

Elapsed Recording Time and Disc Remaining Time Indication

During recording, press **DISPLAY** repeatedly until the desired indication appears on the front display panel.

- Each time you press **DISPLAY**, the time indication changes as follows:

Elapsed recording time → Disc remaining time → Clock → (Back to the beginning)

Free Rate Function

To record the entire program, the unit automatically set the appropriate recording speed depending on the combination of the total time of the program to be recorded and either the remaining disc space or the specified recording time (from 60 minutes to 480 minutes).

To record the entire program within the actual remaining disc space

Select "FR (JUST)" in a recording speed selection procedure.

( pg. 61, 65)

- Note that this function is available only for timer programming recording.

To record the entire program by specifying the desired recording time

Select "FR60–FR360", "FR420" or "FR480" in a recording speed selection procedure. ( pg. 57, 61, 65)

To record a 25-min. long daily program five times just on a same disc for example

Perform "VCR Plus+™ Timer Programming" ( pg. 60) procedure. Be sure to set the recording speed to "FR125" and set Weekly/Daily Rec Function to "MON–FRI" in step **5** to fit the total recording time to the whole disc space.

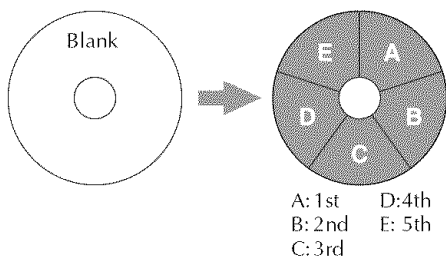

When the same program is recorded in SP mode instead of in "FR125", the 5th program cannot be recorded.

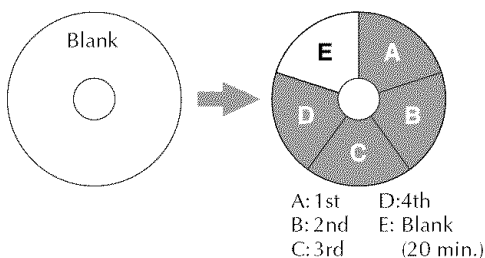

NOTES:

- You can program this unit to timer-record, regardless of the disc remaining time. When the disc remaining time is not enough, recording may stop in the middle of a program. To avoid this, make sure of the disc remaining time before setting timer-programming.
(**Example**) If you programmed to timer-record for 60 minutes in SP mode on a 120-minute disc, the disc remaining time would be 30 minutes in XP mode, 60 minutes in SP mode, 120 minutes in LP mode, 180 minutes in EP mode, and 240 minutes in FR480 mode. Timer-recording will not complete beyond these remaining times.
- The maximum recording time of FR (JUST) mode is the same as the recording time of FR480 mode. When timer-programming a long program in FR (JUST) mode on a disc whose remaining time is short, it is recommended checking the disc remaining time in FR480 mode to see if the remaining time is enough for the program.
- It may not be possible to play back some discs recorded in FR420 or FR480 mode on some other units.
- Even if more than one program are timer-programmed in FR (JUST) mode, only the first one is recorded.
- In order to ensure that the recording fits on the disc, this feature may leave a slight non-recorded section at the end of the disc.
- There may be some noise and sound disturbance at the point on the disc where the unit switches the mode.

Second Audio Recording

This unit's built-in MTS decoder enables reception of Multichannel TV Sound broadcast. To record a SAP program received, set "2ND AUDIO RECORD" to "ON". ( pg. 98)

NOTES:

When the channel is changed on the unit;

- The "MONO" indicator appears on the screen for about 5 seconds if the program is a monoral broadcast.
- The "STEREO" indicator appears on the screen for about 5 seconds if the program is a stereo broadcast.
- Both "STEREO" and "SAP" indicators appear when a stereo program is accompanied by SAP sound.
- Both "MONO" and "SAP" indicators appear when the main audio on the monoral broadcast is accompanied by SAP sound.

VCR Plus+® Timer Programming



You can program this unit to timer-record as many as 8 programs.

With the VCR Plus+ system, timer programming is greatly simplified because each TV program has a corresponding code number which your unit is able to recognize.

You can use the Remote to enter the PlusCode number.

Before performing the VCR Plus+ Timer Programming:

- Turn on the unit.
- Turn on the TV and select the AV mode.
- Slide the **TV/CABLE/DBS/DVD** switch to **DVD**.
- Make sure that the unit's built-in clock is set properly.

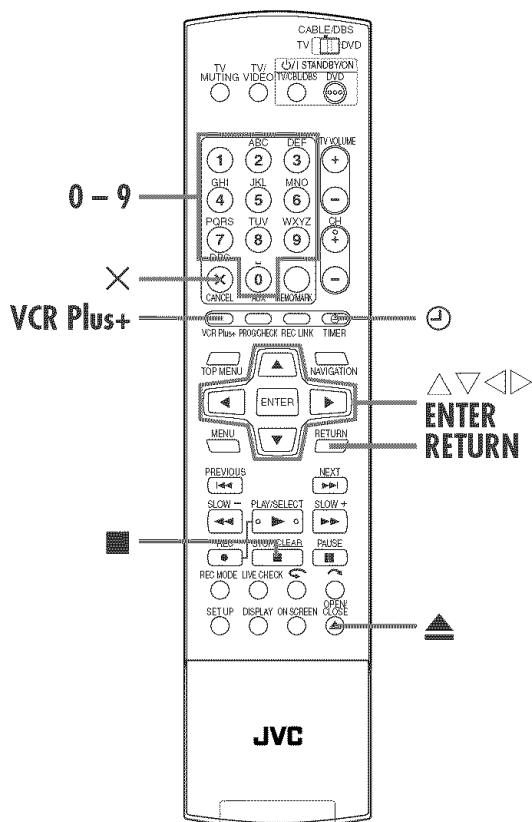

1 Load a disc.

- 1 Press to open the disc tray.
- 2 Place a recordable disc on the disc tray.
 - For details, refer to "Placing a Disc" (pg. 11).
- 3 Press to close the disc tray.

2 Access the VCR Plus+ screen.

Press **VCR Plus+**.

3 Enter the PlusCode number.

Press the **number keys** to enter the PlusCode number of a program you wish to record, then press **ENTER**.

- If you have made a mistake, press **X** and input the correct number before you press **ENTER**.
- To clear all entered numbers at a time, press **■**.
- If the number you entered is invalid, "PLUSCODE NO. ERROR CONFIRM PLUSCODE NO. THEN RETRY" appears on the TV screen. Input a valid PlusCode number.
- If "GUIDE PROGRAM IS NOT SET SELECT CHANNEL YOU WANT TO RECORD" appears on the TV screen, set Guide Channel Numbers (pg. 62) manually.
- When "PROGRAM FULL DELETE UNWANTED TIMER PROGRAM" appears on the TV screen, you need to cancel some of the reserved programs. (pg. 69)

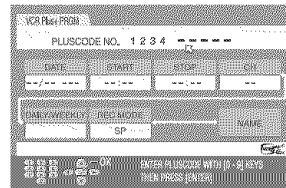

4 Check the program data.

The PlusCode number you entered and the matching timer-recording information are displayed on the TV screen. Check if they are correct.

- To cancel this setting, press **VCR Plus+** or **RETURN**.

IMPORTANT:

Make sure the channel position number you wish to record is displayed; if not, enter manually the channel position number you wish to record.

5 Set the following recording options as required.

- 1 Press ◀▶ to select the desired option.
- 2 Press ▲▼ to select the desired setting, then press ENTER.

“REC MODE” (☞ pg. 58, “Recording Speed”) (☞ pg. 59, “Free Rate Function”), “DAILY/WEEKLY” (☞ pg. 61, “Daily/Weekly Rec Function”), “NAME” (☞ pg. 76, “Modify Program Name”), and “STOP” (To advance/go back the stop time by 30 minutes, press and hold ▲▼).

6 Access the confirmation screen.

Press ENTER.

7 Complete timer programming.

Press ENTER.

- To program another timer, repeat steps 2 – 7.
- If “PROGRAM OVERLAPPED” appears on the TV screen, see “When programs overlap each other” (☞ pg. 70).

8 Engage the unit’s timer mode.

Press ⊕ (TIMER). The unit turns off automatically and “⊕” appears on the front display panel.

- To disengage the timer mode, press ⊕ (TIMER) again.

IMPORTANT

If you have moved to a different area or if a broadcasting station’s channel number has been changed, the wrong channel number will be displayed on the VCR Plus+ program screen in step 2. When this happens, set the correct Guide Channel number for that station. (☞ pg. 60, “VCR Plus+” Timer Programming)

NOTES:

- There may be cases that VCR Plus+ Timer Programming function prolongs the stop time of the programming.
- When two successive programs are recorded on a DVD-RW disc with VCR Plus+ Timer Programming function, the beginning of the second one may be left off the recording.
- VCR Plus+ Timer Programming is not possible on the discs used exclusively for On-Disc Timer Programming.
- If the copy limited program is received during timer-recording, the unit enters Record Pause mode. Recording starts again if it is switched to a recordable broadcast during the time you programmed.

Cable Box or DBS Receiver Users

To timer-record a satellite broadcast using the VCR Plus+ system:

- 1 Perform “Cable Box Control Setting” (☞ pg. 29) or “DBS Receiver Control Setting” (☞ pg. 32).
- 2 Perform “VCR Plus+” Timer Programming”.
- 3 Leave the Cable Box or DBS receiver’s power on.

Daily/Weekly Rec Function

You can record programs with one of the following weekly/daily timer settings.

WEEKLY	Select to record a weekly program.
MON-FRI	Select to record a daily program from Monday through Friday.
MON-SAT	Select to record a daily program from Monday through Saturday.
SUN-SAT	Select to record a daily program from Sunday through Saturday.

Changing VCR Plus+® Setting

- Turn on the unit.
- Turn on the TV and select the AV mode.
- Slide the TV/CABLE/DBS/DVD switch to DVD.

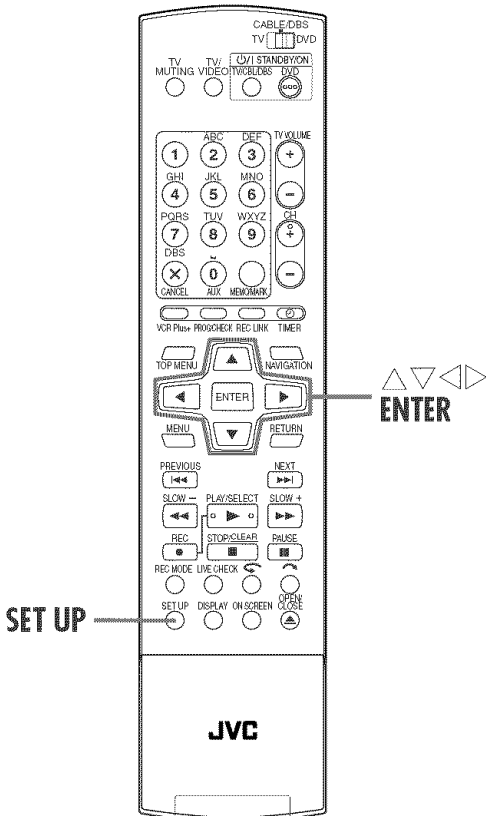

The VCR Plus+ programming system assigns a VCR Plus+ guide channel to the TV channels and the cable channels. These guide channel numbers are also called the VCR Plus+ channel codes. Most TV listings have a section, usually a chart, indicating the guide channel numbers assigned to each station.

To ensure that VCR Plus+ timer recording operates correctly, it is necessary to set the VCR Plus+ "Guide Channel Set" for each station.

If you have moved to a different area or if a broadcasting station's channel number has been changed, perform the following steps to set the correct guide channel number.

NOTES:

- In many instances, the VCR Plus+ guide channel numbers for cable and broadcast TV stations DO NOT match the channel number on which it is received by your unit or cable box. Check your TV listing, or contact your cable supplier for details.
- Many TV stations can be viewed on cable. Check your TV listing, or contact your cable supplier for details.

Guide Channel Number Set

1 Access the Main Menu screen.

Press **SET UP**.

2 Access the "TUNER SET" screen.

- 1 Press $\triangleleft \triangleright$ to select "INITIAL SET UP", then press **ENTER**.
- 2 Press $\triangleleft \triangleright$ to select "TUNER SET", then press **ENTER**.

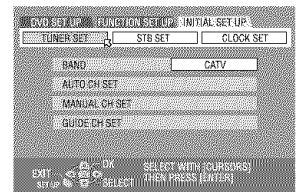

3 Enter the Guide Channel number.

- 1 Press $\triangle \nabla$ to select "GUIDE CH SET", then press **ENTER**.
- 2 Press $\triangle \nabla$ to select "GUIDE CH", then press **ENTER**.
- 3 Press $\triangle \nabla$ to select the Guide Channel number for the desired station as shown in the TV listings. Then press **ENTER**.

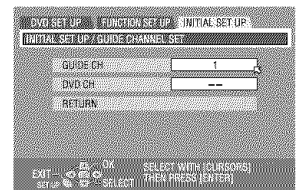

- To change the Guide Channel number in 10 increments, press and hold $\triangle \nabla$.
- If you receive your channels with a cable box and if you have properly set your Controller, "CATV CH" appears in place of "DVD CH". If not, perform "Changing VCR Plus+® Setting" (pg. 62).

4 Enter the receiving channel position number.

- 1 Press \triangle/∇ to select "DVD CH", then press **ENTER**.
 - 2 Press \triangle/∇ to select the number of the unit's channel position on which the Guide Channel number's broadcast is received by the unit or the DBS receiver. Then press **ENTER**.
- To timer-record a satellite program with the VCR Plus+ system, you need to install a supplied Controller and perform the procedure described in "Cable Box Control Setting" (☞ pg. 29) or "DBS Receiver Control Setting" (☞ pg. 32).
 - Repeat steps 3 and 4 as necessary.

5 Complete the setting.

Press **SET UP**.

Guide Channel Number

"Guide Channel (GUIDE CH) number" refers to the assigned TV station numbers, according to broadcast area, for the VCR Plus+ timer recording. The Guide Channel numbers can be found in most TV listings.

Manual Timer Programming



You can program this unit to timer-record as many as 8 programs.

If you do not know the PlusCode number for the program you wish to record, use the following procedure to set your unit to timer-record the program.

Before performing Manual Timer Programming:

- Turn on the unit.
- Turn on the TV and select the AV mode.
- Slide the TV/CABLE/DBS/DVD switch to DVD.
- Make sure that the unit's built-in clock is set properly.

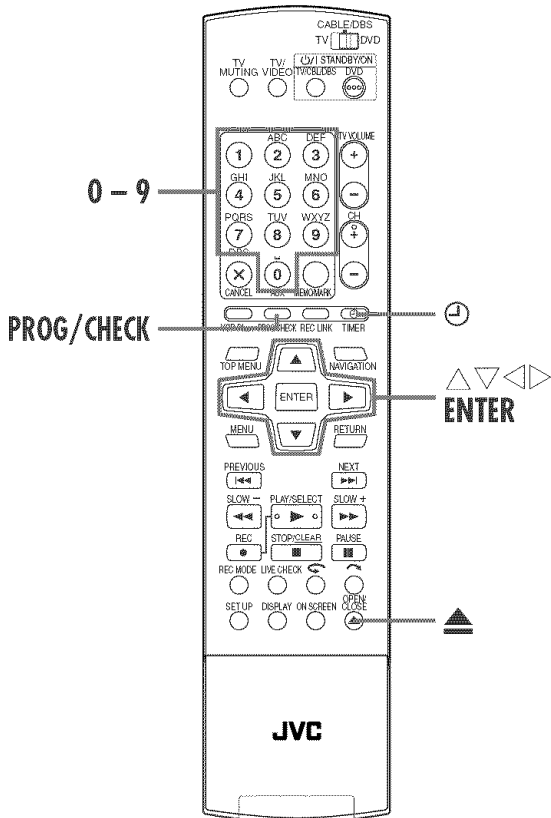

1 Load a disc.

- 1 Press \blacktriangle to open the disc tray.
- 2 Place a recordable disc on the disc tray.
- For details, refer to "Placing a Disc" (pg. 11).
- 3 Press \blacktriangle to close the disc tray.

2 Access Program Check screen.

Press **PROG/CHECK**.

- When "PROGRAM FULL DELETE UNWANTED TIMER PROGRAM" appears on the TV screen, you need to cancel some of the reserved programs. (pg. 69)

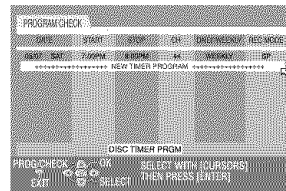

3 Access the program screen.

Press \triangle / ∇ repeatedly to select "NEW TIMER PROGRAM", then press **ENTER**.

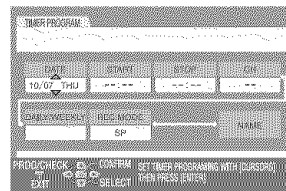

4 Enter the recording date.

Press \triangle / ∇ repeatedly to set the desired date.

- The current date appears on the TV screen. The date you enter appears in its place.

5 Enter the recording start time.

Press \triangle / ∇ to select "START", then press \triangle / ∇ repeatedly to set the desired start time.

- Each press of \triangle / ∇ advances/goes back the start time in 1-min. increments.
- To advance/go back the start time in 30-min. increments, press and hold \triangle / ∇ .

6 Enter the recording stop time.

Press ◀▶ to select "STOP", then press ▲▼ repeatedly to set the desired stop time.

- Each press of ▲▼ advances/goes back the stop time in 1-min. increments.
- To advance/go back the stop time in 30-min. increments, press and hold ▲▼.

7 Enter the channel position.

Press ◀▶ to select "CH", then press ▲▼ repeatedly to select the desired channel.

- If you are using a DBS receiver, see "ATTENTION FOR DBS RECEIVER USERS" in the right column.

8 Set the other recording options as required.

Refer to step 5 in "VCR Plus+® Timer Programming" (pg. 60).

9 Access the confirmation screen.

Press ENTER.

10 Complete timer programing.

Press ENTER.

- To program another timer, repeat steps 2 – 10.

11 Engage the unit's timer mode.

Press ⊕ (TIMER). The unit turns off automatically and "⊕" appears on the front display panel.

- To disengage the timer mode, press ⊕ (TIMER) again.

NOTES:

- When two successive programs are recorded on a DVD-RW disc with Manual timer programing recording function, the beginning of the second one may be left off the recording.
- If the copy limited program is received during timer-recording, the unit enters Record Pause mode. Recording starts again if it is switched to a recordable broadcast during the time you programed.

Cable Box or DBS Receiver Users

To timer-record a satellite broadcast using Manual Timer Programming:

- 1 Perform "Cable Box Control Setting" (pg. 29) or "DBS Receiver Control Setting" (pg. 32).
- 2 Perform "Manual Timer Programming".
- 3 Leave the Cable Box or DBS receiver's power on.

ATTENTION FOR DBS RECEIVER USERS

If you are using a DBS receiver (unless "DBS RECEIVER SET" is set to "OFF" (pg. 33), the band indication (TV, CATV or DBS) appears on the left of the channel number indication. No indication:

To timer-record a regular TV broadcast received on the unit.

CATV: To timer-record a cable TV broadcast received on the unit, or through a cable box (unless "CABLE BOX SET" is set to "OFF" (pg. 30).

DBS: To timer-record a satellite broadcast received through a DBS receiver.

NOTE:

If the channel number entered requires that the band be set, "7=DBS" is displayed on the screen.

If this happens, press the DBS (number key "7") to select "DBS".

On-Disc Timer Programming



On-Disc Timer Programming is a function used with discs that are especially intended for a specific program. The disc is then programmed for a program you always watch every day or every week. Since older programs are automatically overwritten, a single DVD-RAM/RW (VR mode) disc can be used without worrying about how much recording capacity remains. (☞ pg. 68, "How discs are overwritten")

You can program each disc to timer-record as many as 8 programs.

Before performing On-Disc Timer Programming:

- Turn on the unit.
- Turn on the TV and select the AV mode.
- Slide the TV/CABLE/DBS/DVD switch to DVD.
- Make sure that the unit's built-in clock is set properly.

ATTENTION:

- On-Disc Timer Programming is possible only with the disc for On-Disc Timer Programming.
- If data is recorded on a disc for On-Disc Timer Programming using a unit from another manufacturer, On-Disc Timer Programming may no longer function properly.

To make the disc for On-Disc Timer Programming

1 Load a disc.

- 1 Press ▲ to open the disc tray.
- 2 Place a recordable disc on the disc tray.
- 3 Press ▲ to close the disc tray.

2 Access Program Check screen.

Press **PROG/CHECK**.

3 Access the program screen.

When On-Disc Timer Programming is made for the first time on the disc

Press ▲▼ repeatedly to select "DISC TIMER PRGM", then press **ENTER**.

- When some programs are recorded on the disc, a caution message appears. In such a case, backup the programs as required, then format the disc before making On-Disc Timer Programming. (☞ pg. 101, "Format a disc")

When On-Disc Timer Programming has already been made on the disc

Press ▲▼ repeatedly to select "NEW TIMER PROGRAM", then press **ENTER**.

4 Enter the recording date.

Press ▲▼ repeatedly to set the desired date.

- The current date appears on the TV screen. The date you enter appears in its place.

5 Enter the recording start time.

Press ◀▶ to select "START", then press ▲▼ repeatedly to set the desired start time.

- Each press of ▲▼ advances/goes back the start time in 1-min. increments.
- To advance/go back the start time in 30-min. increments, press and hold ▲▼.

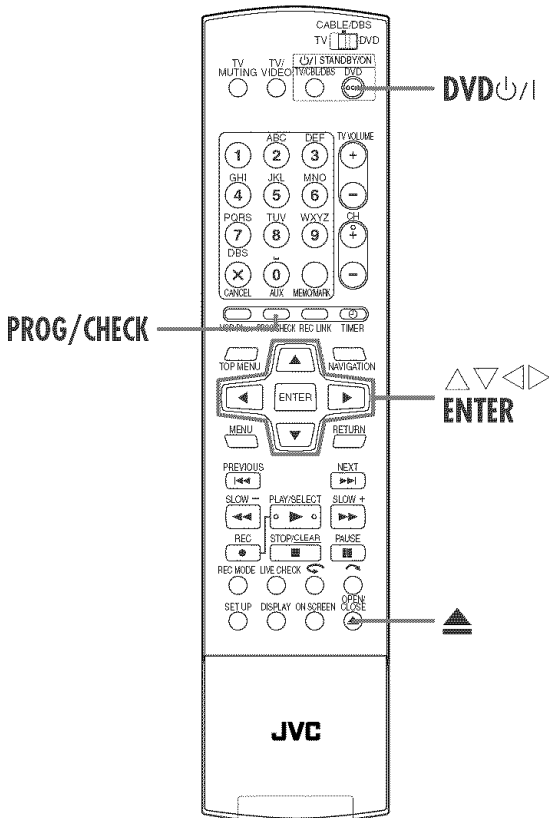

6 Enter the recording stop time.

Press ◀▶ to select "STOP", then press ▲▼ repeatedly to set the desired stop time.

- Each press of ▲▼ advances/goes back the stop time in 1-min. increments.
- To advance/go back the stop time in 30-min. increments, press and hold ▲▼.

7 Enter the channel position.

Press ◀▶ to select "CH", then press ▲▼ repeatedly to select the desired channel.

8 Set "DAILY/WEEKLY" option.

Refer to step 5 in "VCR Plus+® Timer Programming" (☞ pg. 60).

- It is necessary to set "DAILY/WEEKLY" option for On-Disc Timer Programming. (☞ pg. 61, "Daily/Weekly Rec Function")

9 Set the other recording options as required.

Refer to step 5 in "VCR Plus+® Timer Programming" (☞ pg. 60).

- You can select XP, SP, LP, EP or FR480 mode for "REC MODE". You cannot select FR (JUST), FR60–FR360 and FR420.

10 Access the confirmation screen.

Press ENTER.

11 Complete timer programming.

Press ENTER.

- To program another timer, repeat steps 2 – 11.

To timer-record the program with the programmed disc

1 Load the disc.

- 1 Press ▲ to open the disc tray.
- 2 Place the programmed disc on the disc tray.
 - For details, refer to "Placing a Disc" (☞ pg. 11).
- 3 Press ▲ to close the disc tray.

2 Engage the unit's timer mode.

Press DVD ⏪/I. The unit turns off and "DISC ⏪" appears on the front display panel.

- To disengage the timer mode, press DVD ⏪/I again.

NOTES:

- Even if On-Disc Timer Programming is overlapping with other timer programming, any caution message does not appear. In such a case, recording will be executed in the descending order of the recording start time of the program.
- On-Disc Timer Programming is not possible on a DVD-RW disc formatted in video mode. (☞ pg. 101, "Format a DVD-RW disc")
- The information of a program recorded with On-Disc Timer Programming is not stored in the library. (☞ pg. 82)
- The play list is not created for the programs recorded with On-Disc Timer Programming. (☞ pg. 78)
- VCR Plus+ Timer Programming is not possible on the discs used exclusively for On-Disc Timer Programming.
- Manual Timer Programming is not possible on the On-Disc Timer Programmed disc. (☞ pg. 64)
- Basic Recording is not possible on the On-Disc Timer Programmed disc. (☞ pg. 57)
- The On-Disc Timer Programming function does not work on the unit from other manufactures even if the On-Disc Timer Programmed disc is loaded.
- The beginning of a program may not be recorded. Also, if the 1st program's recording stop time and the 2nd program's recording start time is the same, the ending of the 1st program may not be recorded.
- If there is a power cut while recording, the recordings before the power cut are not guaranteed.

Cable Box or DBS Receiver Users

To timer-record a satellite broadcast using the On-Disc Timer Programming function:

- 1 Perform "Cable Box Control Setting" (☞ pg. 29) or "DBS Receiver Control Setting" (☞ pg. 32).
- 2 Perform "On-Disc Timer Programming".
- 3 Leave the Cable Box or DBS receiver's power on.

How discs are overwritten

(Example 1)

To record a 1-hour serial drama every Friday in SP mode

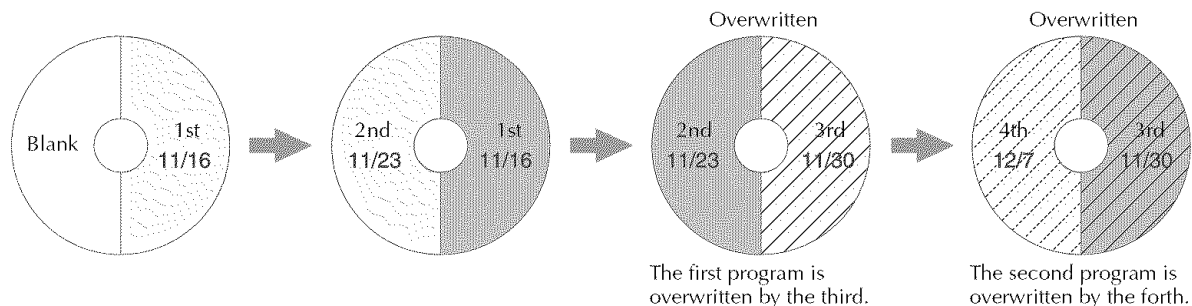

(Example 2)

To record a 15-minute serial drama every morning in XP mode

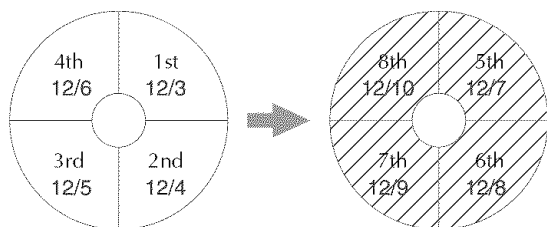

(Example 3)

To record a 90-minute serial drama every Sunday in SP mode

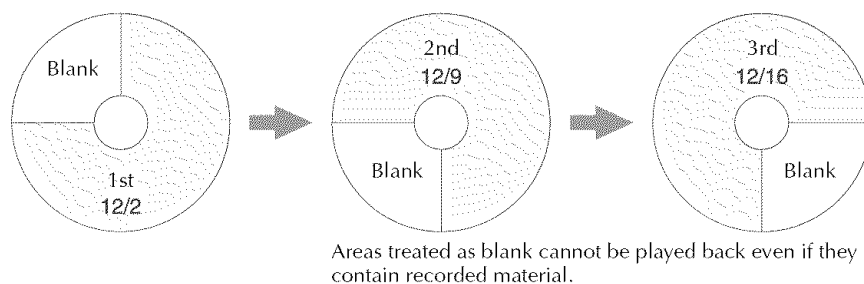

NOTE:

On-Disc Timer Programming may not always work as these examples.

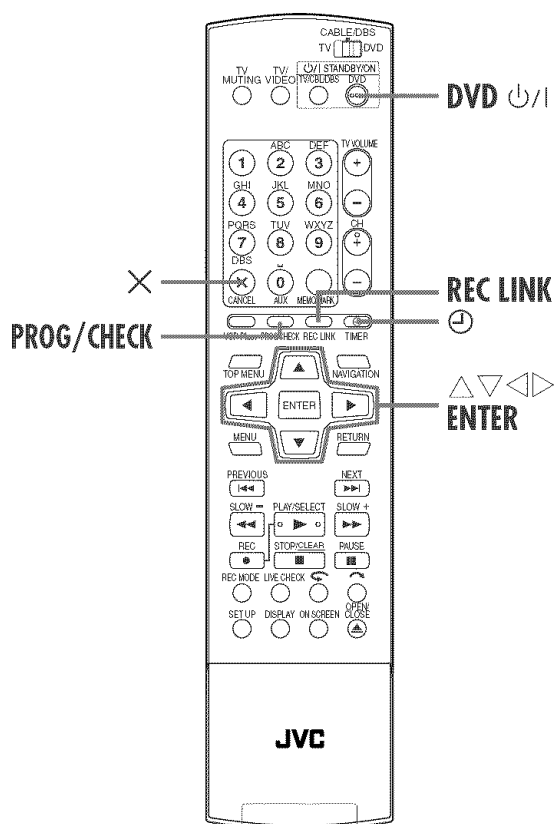

Check, cancel and change programs

1 Disengage the timer mode.

When "Ⓢ" lights on the front display panel
Press **TIMER**, then press **DVD** $\psi/!$.

When "DISC" lights on the front display panel
Press **DVD** $\psi/!$.

When "R-LK" lights on the front display panel
Press **REC LINK**, then press **DVD** $\psi/!$.

2 Access Program Check screen.

Press **PROG/CHECK**.

- To return to the previous screen after you check the program, press **PROG/CHECK** again.

To cancel the program
Press \triangle/∇ repeatedly to select a program to be cancelled, then press \times .

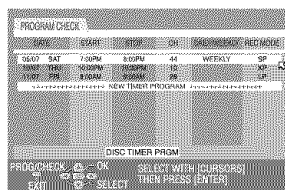

3 Access the program screen.

Press \triangle/∇ to select the program, then press **ENTER**.

4 Change a program.

Change the settings of the desired recording options as required.

- Refer to steps **1** – **9** in "Manual Timer Programming" (pg. 64).

5 Complete timer correction.

Press **PROG/CHECK**.

- The previous screen resumes.

6 Engage the unit's timer mode.

For VCR Plus+ or Manual Timer Programming
Press **TIMER**.

For On-Disc Timer Programming
Press **DVD** $\psi/!$.

For Satellite Auto Recording
Press **REC LINK** for 2 seconds or more.

Program's information on the front display panel

You can check the details of the programs even when the power is turned off. (It is necessary that the Power Save mode (pg. 99, "POWER SAVE") is disengaged or the unit is not in timer standby mode.) However, it is not possible to cancel or change the program's setting.

- Press **PROG/CHECK**.
 - "NEW PROG" or "P-1" (if 8 programs have already been set) appears.
- Press \triangle/∇ repeatedly until the desired program number ("P-1" to "P-8") appears, then press **ENTER**.
- Press \triangleright .
 - Each time you press \triangleright , the indication changes as follows (the settings in parentheses are examples):
Date ("DATE 03.08SU") → Start time ("ON 11:00") → Stop time ("OFF 11:30") → Channel ("CH 1") → Weekly/Daily ("MO-FR DAILY") → Program number ("P-1") and Recording speed (SP) → (Back to the beginning)
- Press **PROG/CHECK** to complete checking.
 - The normal display resumes.

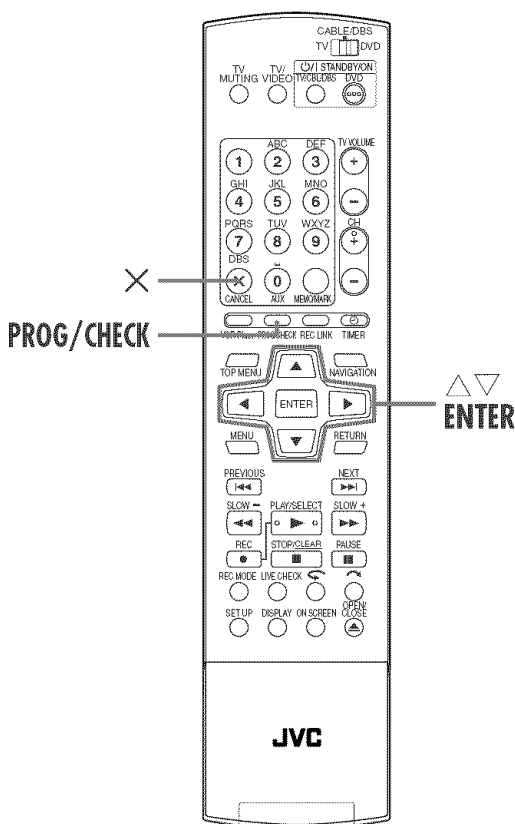

When programs overlap each other

If "PROGRAM OVERLAPPED" appears, you have another program overlapping the program you have just made. Confirm with the arrow on "OK", then press **PROG/CHECK**. Program Check appears and conflicting programs will be highlighted in pink.

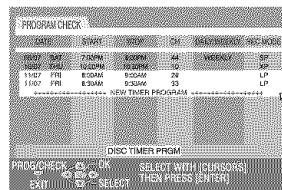

Example: Program 3 (you have just made) and Program 4 overlap each other.

1 Confirm the overlapping programs.

Overlapping programs appear on the TV screen.

NOTE:

If you do not mind this overlap, press **PROG/CHECK** to finish the timer program setting. The program with the lower program number will be recorded and the other one will not be recorded correctly. If no changes are made for approximately 1 minute, the unit will return to the normal screen.

2 Select the desired program to be cancelled or changed.

Press \triangle/∇ .

To cancel the program

Press **X**.

- "THE TIMER PROGRAMMING SETTING WAS CANCELLED" appears on the TV screen for about 5 seconds, then the normal screen resumes.

To change the program setting

Press **ENTER**.

3 Change the program setting.

- Refer to steps **4** – **10** in "Manual Timer Programming" (pg. 64).

4 Check if the conflict has been settled.

Press **PROG/CHECK**.

- Program check screen appears.

5 Engage the unit's timer mode.

- Refer to step **6** in "Check, cancel and change programs" (pg. 69).

NOTE:

When any overlaps remain after deletion and modification of programs, Program Check screen remains showing the conflicting programs. In such a case, repeat the procedure above until the conflict is solved.

Satellite Auto Recording



This function allows you to automatically record a satellite program which is timer-programed on your external DBS receiver. Connect a DBS receiver to the unit's AUDIO/VIDEO INPUT (L-1) connectors and program the timer on the DBS receiver. The unit starts or stops recording by the signals input from the DBS receiver. After recording, the unit's power shuts off automatically.

- You can also connect the cable box if it has a timer.

ATTENTION

- Be sure not to turn on the DBS receiver before the program is executed; otherwise, the unit will start recording when the DBS receiver's power is turned on.
- If you have connected another appliance other than a DBS receiver to the AUDIO/VIDEO INPUT (L-1) connectors, be sure not to engage the Satellite Auto Recording mode; otherwise, the unit will start recording when the connected appliance's power is turned on.
- Satellite Auto Recording and timer-recording cannot be done at the same time.

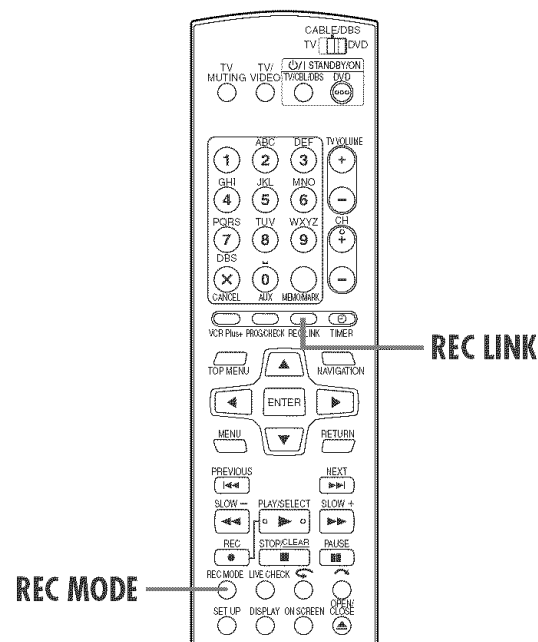
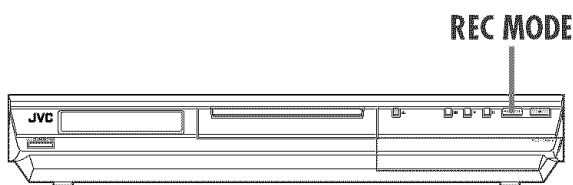

Before performing the following steps:

- Make sure the DBS receiver is connected to the unit's AUDIO/VIDEO INPUT (L-1) connectors.
- Program the timer on the DBS receiver.
- Slide the TV/CABLE/DBS/DVD switch to DVD.

1 Set the recording speed.

Press **REC MODE**.

2 Engage the Satellite Auto Recording mode.

Press and hold **REC LINK** for about 2 seconds. "R-LK" appears on the front display panel and the unit turns off automatically.

NOTES:

- To disengage the Satellite Auto Recording mode, press **REC LINK**.
- If the unit's power is off, it is not possible to engage the Satellite Auto Recording mode.
- In step **2**, if "R-LK" blinks quickly on the front display panel even though your DBS receiver's power is off, Satellite Auto Recording will not work properly with that DBS receiver*. If this is the case, perform "Manual Timer Programming" (pg. 64) to timer-record a satellite program.
* Some DBS receivers output signals even if the power is off. Satellite Auto Recording is not possible with those DBS receivers.
- "R-LK" blinks on the front display panel while Satellite Auto Recording is in progress.
- For timer programming of the DBS receiver, refer to the instruction manual of the DBS receiver.
- Satellite Auto Recording is not possible if your DBS receiver does not have a timer.
- Pressing the unit's **ON/OFF** button while Satellite Auto Recording is in progress turns off the unit's power and disengages the Satellite Auto Recording mode.
- If there are more than one satellite programs you wish to record with Satellite Auto Recording, it is not possible to set different recording speeds for each program.
- Depending on the type of DBS receiver, the unit may not record a slight portion of the beginning of the program or may record slightly longer than the actual length of the program.
- If you engage the Satellite Auto Recording mode when the DBS receiver's power is on, the unit will not start Satellite Auto Recording even though "R-LK" blinks on the front display panel. When the DBS receiver shuts off once and is turned back on again, the unit starts recording.
- You can also record a program from your cable system in the same way if the system has a timer.
- When the Satellite Auto Recording mode is engaged, or the unit's power is turned off after Satellite Auto Recording is finished, the unit will not enter the Timer mode even though "AUTO TIMER" is set to "ON" (pg. 100).

Library Database DVD Navi



The following screen appears as the Library Database DVD Navi screen when you press **NAVIGATION**. You can move the arrow to select the desired position on the screen by pressing $\triangle \nabla \triangleleft \triangleright$ on the Remote.

- 1 Index
(Small still picture of each program)
- 2 Names of functions
ORIGINAL (pg. 75)
PLAY LIST (pg. 78)
LIBRARY (pg. 82)
- 3 Remaining time
(Based on the recording speed currently selected)
- 4 Current/Total number of program(s)
(For example, there are 6 recorded programs and the program indicated by the arrow is the 3rd one.)
- 5 Icons
(Indicate the recording situation for each program.)
- 6 Recording information for the program indicated by the arrow
- 7 Guidance for operations
- 8 Operational commands

The Icons and their meanings

	This program is write-protected.
	This program has stereo sounds.
	This program was recorded with timer recording.

Using Library Database DVD Navi system, you can easily modify registered information, edit the program or play list, as well as search for the beginning of each program.

About registration of information

The following information is automatically registered for each program when ordinary recording or timer recording is performed, then stored in an area specified on the unit.

- index* (reduced still pictures to show program titles)
- program title*
- category*
- date and time
- channel
- recording speed
- length of recording time

The items marked with an asterisk (*) can be easily modified and registered again after recording by using Library Database DVD Navi system.

About editing of programs

Library Database DVD Navi system has the following functions for editing of programs.

- “Modify Original Information” (Ⓛ pg. 75)
- “Delete program” (Ⓛ pg. 77)

The limitations of registration

You can register information up to 99 programs.

When the amount of information is at the limits of registration, you cannot record new program any more. In this case, you need to delete old programs to register new one. (Ⓛ pg. 77, “Delete program”)

NOTE:

Once a DVD-R/RW (Video mode) disc has been finalized, the displays for original and play list do not appear. Only display for library appears.

The display for original recording

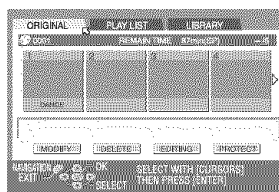

The display for play list

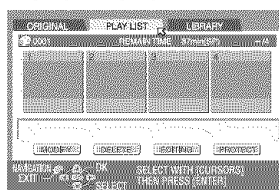

The display for library

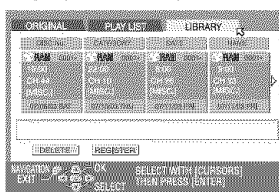

Scan for Beginning(s) of Program(s)

- Turn on the TV and select the AV mode.
- Slide the TV/CABLE/DBS/DVD switch to DVD.

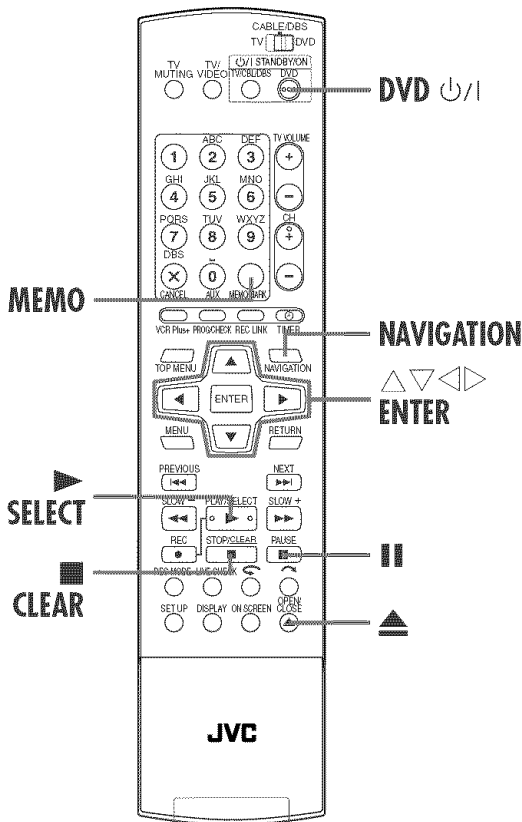

You can scan the beginning of the program easily with the Library Database DVD Navi.

1 Turn on the unit.

On the unit
Press **⏻**.

On the Remote
Press **DVD** **⏻**.

2 Load a disc.

- 1 Press **⏻** to open the disc tray.
- 2 Place a recorded disc on the disc tray.
 - For details, refer to "Placing a Disc" (pg. 11).
- 3 Press **⏻** to close the disc tray.

3 Access the Index screen.

- 1 Press **NAVIGATION**. The Library Database DVD Navi screen appears.
- 2 Press **⏻** to move the arrow to "ORIGINAL", then press **ENTER**.

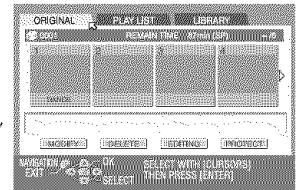

4 Select the program(s).

Press **⏻** to move the arrow on the index (small still pictures) of the desired program.

- When you want the plural programs to be played back continuously, press **MEMO** after selecting the desired program. The numbers of the playback order appear on the index. You can select up to 30 programs.
- When you want to correct the order, move the arrow on the desired index and press **MEMO**. The number disappears and the unit re-numbers the other programs automatically.
- When you want to cancel the order, press **CLEAR**.

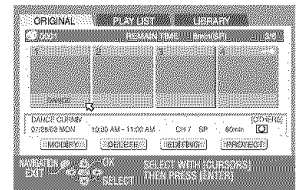

5 Start playback.

Press **ENTER**. Or simply press **SELECT**. The playback starts.

6 Pause playback.

Press **⏸**.

- To resume normal playback, press **▶**.

7 Stop playback.

Press **■**.

Modify Original Information



- Turn on the TV and select the AV mode.
- Slide the TV/CABLE/DBS/DVD switch to DVD.

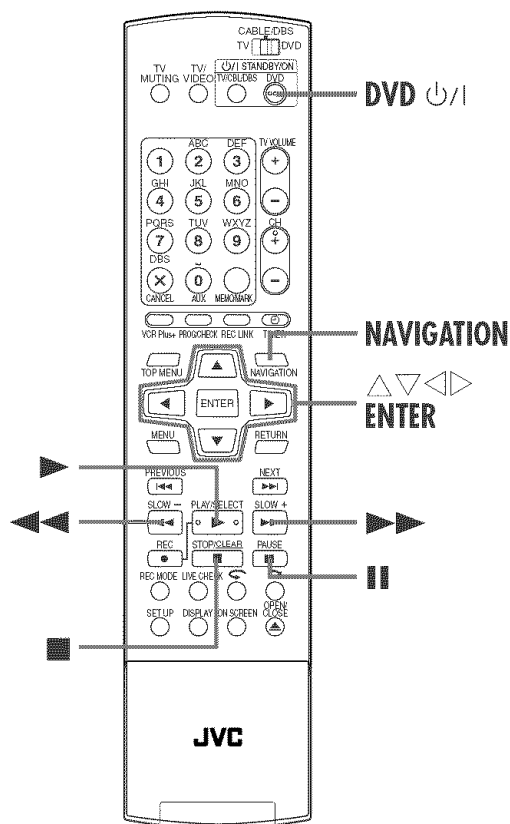

Modify Index

1 Turn on the unit.

On the unit
Press 0/I.

On the Remote
Press DVD 0/I.

2 Access the Index screen.

- 1 Press NAVIGATION. The Library Database DVD Navi screen appears.
- 2 Press $\Delta \nabla \triangleleft \triangleright$ to move the arrow to "ORIGINAL", then press ENTER.

3 Select a program.

Press $\Delta \nabla \triangleleft \triangleright$ to move the arrow to select one program you want to modify, then press ∇ .

4 Access the modify screen.

- 1 Press $\Delta \nabla \triangleleft \triangleright$ to move the arrow to "MODIFY", then press ENTER.
- 2 Press $\triangleleft \triangleright$ to move the arrow to "MODIFY INDEX". The "MODIFY INDEX" screen appears.

5 Register new index.

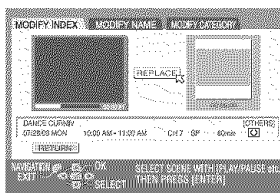
- 1 Search for the picture from the program by pressing the appropriate buttons ($\triangleleft \triangleright$, $\ll \gg$, or \parallel). The pictures of the program appear on the left window.
 
- 2 Confirm the arrow is on "REPLACE", then press ENTER to register new index. New index appears on the right window.
 - When you press ENTER with the arrow on "RETURN" you can return to the previous screen.

6 Return to the normal screen.

Press NAVIGATION.

- Press \blacksquare to cancel pause mode after pressing NAVIGATION.

Modify Program Name

Perform steps **1** to **3** of "Modify Index" (☞ pg. 75) before continuing.

1 Access the modify screen.

- Press $\Delta \nabla \triangleleft \triangleright$ to move the arrow to "MODIFY", then press **ENTER**.
- Press $\triangleleft \triangleright$ to move the arrow to "MODIFY NAME". The "MODIFY NAME" screen appears.

2 Enter new name.

Press $\Delta \nabla \triangleleft \triangleright$ to move the arrow to the desired letter or command, then press **ENTER**. Repeat this process to complete the name.

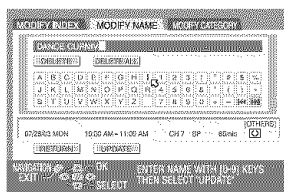

- To correct a letter, press $\Delta \nabla \triangleleft \triangleright$ to move the arrow to "DELETE" or "DELETE ALL", then press **ENTER**.
- You can enter the letters up to 64.
- You can also enter the new name with **number keys**. For example, when you press **2** repeatedly, "A", "B", "C", "a", "b", "c", "2", and then "A" appear by turns. You can use the following buttons.

Number keys: for entering letters, numbers and blank space
 $\triangleleft \triangleright$ **buttons:** for moving the entering or inserting point
 ■ **button:** for correcting a letter
 ◀▶ **buttons:** for changing character tables

3 Register new name.

Press $\Delta \nabla \triangleleft \triangleright$ to move the arrow to "UPDATE", then press **ENTER**.

4 Return to the Library Database DVD Navi screen.

Press $\Delta \nabla \triangleleft \triangleright$ to move the arrow to "RETURN", then press **ENTER**. The Library Database DVD Navi screen appears again.

5 Return to the normal screen.

Press **NAVIGATION**.

Modify Category

Perform steps **1** to **3** of "Modify Index" (☞ pg. 75) before continuing.

1 Access the modify screen.

- Press $\Delta \nabla \triangleleft \triangleright$ to move the arrow to "MODIFY", then press **ENTER**.
- Press $\triangleleft \triangleright$ to move the arrow to "MODIFY CATEGORY". The "MODIFY CATEGORY" screen appears.

2 Select new category.

Press $\Delta \nabla \triangleleft \triangleright$ to move the arrow to the desired category, then press **ENTER**.

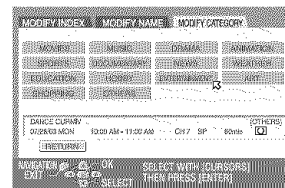

3 Register new category.

Press **ENTER**. The Library Database DVD Navi screen appears again.

4 Return to the normal screen.

Press **NAVIGATION**.

Protect title

You can protect the program to prevent accidental erasure of the important program.

Perform steps **1** to **2** of "Modify Index" (☞ pg. 75) before continuing.

1 Select a program.

Press $\Delta \nabla \triangleleft \triangleright$ to move the arrow to a program you want to protect, then press ∇ .

2 Protect the program.

Press $\triangleleft \triangleright$ to move the arrow to "PROTECT", then press **ENTER**.

- "" appears.
- To cancel the protection, repeat **1** - **2** again.

3 Return to the normal screen.

Press **NAVIGATION**.

NOTE:

All the programs on a disc will be deleted once the disc is formatted even if they are protected titles. (☞ pg. 101)

Delete program

You cannot record any more with Library Database DVD Navi once the registered programs on the disc reach 99 programs. Deleting unnecessary programs after dubbing (☞ pg. 89, "Edit To Or From Another Recorder") or other operations can increase remaining time and available recording capacity. (For DVD-R discs, although it is possible to delete recorded programs, available recording capacity does not increase.) The deleted program is never resumed. Play lists and program information in the unit's library are also deleted.

Perform steps **1** to **2** of "Modify Index" (☞ pg. 75) before continuing.

1 Select a program.

Press ◀▶ to move the arrow to select one program you want to delete, then press ▽.

2 Access the delete screen.

Press △▽◀▶ to move the arrow to "DELETE", then press ENTER. The message appears for your confirmation.

3 Confirm the deletion.

Press ◀▶ to select "YES", then press ENTER.

- When you cancel the deletion, select "NO", then press ENTER.

4 Return to the normal screen.

Press NAVIGATION.

Delete unwanted part of the program

You can delete unwanted part of the program.

Perform steps **1** to **2** of "Modify Index" (☞ pg. 75) before continuing.

1 Select a program.

Press ◀▶ to move the arrow to select one program whose unwanted part you want to delete, then press ▽.

2 Access the delete screen.

Press ◀▶ to move the arrow to "EDITING", then press ENTER.

3 Start playback.

Press ▶ to start playback. The playback pictures appear in the window on the screen. The elapsed playing time starts counting with the arrow on "IN".

4 Set edit-in and edit-out points.

- Find the point where you want the deletion to begin, then press ENTER with the arrow on "IN". The edit-in time is fixed and the elapsed playing time starts counting again.
- Find the point where you want the deletion to end, then press ENTER with the arrow on "OUT". The edit-out time is fixed.
 - Press ◀◀, ▶▶, ◀▶▶, ▶▶▶ or || to find the edit-in and edit-out points.

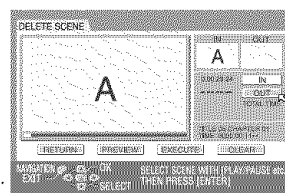

5 Confirm the deletion.

- Press △▽◀▶ to move the arrow to "PREVIEW", then press ENTER to preview the edited program.
- Press △▽◀▶ to select "EXECUTE", then press ENTER.
 - If you do not want to delete the scene, select "CLEAR" and press ENTER.
- Press ◀▶ to select "YES", then press ENTER.
 - The selected scene is deleted.
 - To cancel the deletion, press ◀▶ to select "NO", then press ENTER.

To modify the points

- Press ◀▶ to move the arrow to "CLEAR", then press ENTER.
- Repeat step **3** – **5**.

6 Return to the normal screen.

Press NAVIGATION.

NOTES:

- There may be a discrepancy of several seconds between the scene you intend to edit, and the scene which is actually edited.
- Available recording capacity may not match the deleted part after deletion.

Modify Play List Information



- Turn on the TV and select the AV mode.
- Slide the TV/CABLE/DBS/DVD switch to DVD.

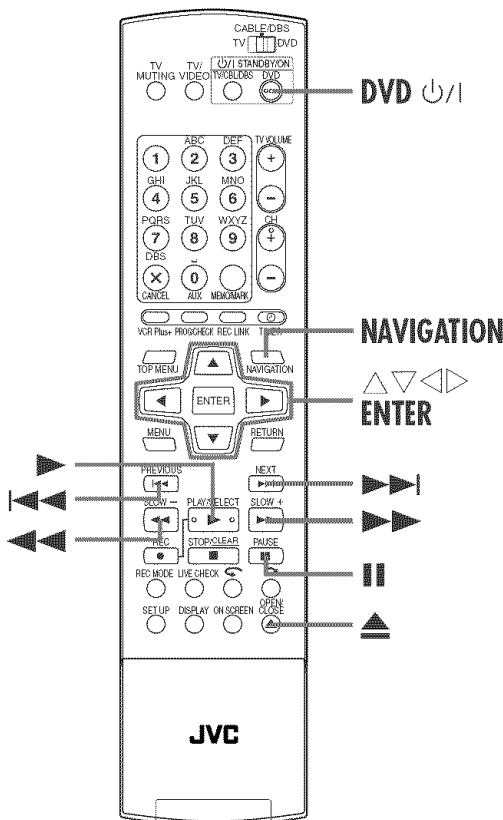

■ Play List

It is a collection of the scenes. A play list can be freely edited and played back without ever changing any original recording data.

Using the random access of a DVD disc (which allows video data to be instantly read no matter where it is on the disc), a play list includes information such as the timer counter for the playback start point and end point, indexes for checking the contents of recorded data, category information, and more. Playback according to a play list you have created allows you to enjoy various combinations of video images from a single program.

Create Play List

1 Turn on the unit.

On the unit
Press **⏻/I**.

On the Remote
Press **DVD ⏻/I**.

2 Load a disc.

- 1 Press **⏻** to open the disc tray.
 - 2 Place a DVD-RAM or DVD-RW (VR mode) disc that was recorded with this unit on the disc tray.
 - 3 Press **⏻** to close the disc tray.
- For details, refer to "Placing a Disc" (pg. 11).

3 Access the Play List screen.

- 1 Press **NAVIGATION**. The Library Database DVD Navigation screen appears.
- 2 Press **⏻** to move the arrow to "PLAY LIST", then press **▽** or **ENTER**.

4 Create a play list.

Press **⏻** to move the arrow to "CREATE", then press **ENTER**.

5 Start playback.

Press **▶** to start playback. The playback pictures appear in the window on the screen. The elapsed playing time starts counting with the arrow on "IN".

- To locate the beginning of other titles, press **⏮**.

6 Set edit-in and edit-out points.

- 1 Find the point where you want the created play list to begin, then press **ENTER** with the arrow on "IN". The edit-in time is fixed and the elapsed playing time starts counting again.
 - 2 Find the point where you want the created play list to end, then press **ENTER** with the arrow on "OUT". The edit-out time is fixed.
- Press **⏮**, **▶**, **⏭**, **⏮**, **▶** or **⏸** to find the edit-in and edit-out points.
 - The edit-out point must come after the edit-in point.

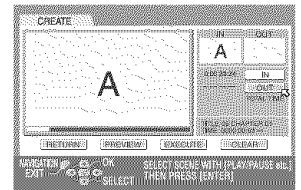

7 Confirm the play list.

- 1 Press **⏻** to move the arrow to "PREVIEW", then press **ENTER** to preview the play list.
 - 2 Press **⏻** to select "EXECUTE", then press **ENTER**.
- The play list is created.

To modify the points

- 1 Press ◀▶ to move the arrow to “CLEAR”, then press **ENTER**.
- 2 Repeat step **5** – **7**.

8 Return to the normal screen.

Press **NAVIGATION**.

NOTES:

- There may be a discrepancy of several seconds between the scene you intend to edit, and the scene which is actually edited.
- The title, index and category of the play list can be modified in the same way as “ORIGINAL”. (☞ pg. 75, “Modify Original Information”)
- You can modify the play list that has just been created here by adding, moving, or deleting unwanted parts to create a digest edition, etc.

Add scenes to a play list

Perform steps **1** to **3** of “Create Play List” (☞ pg. 78) before continuing.

1 Select a play list.

Press ◀▶ to move the arrow to the play list to which you wish to add a scene, then press ▽.

2 Access the Editing screen.

- 1 Press ◀▶ to move the arrow to “EDITING”, then press **ENTER**.
- 2 Press ◀▶ to move the arrow to “ADD SCENE”.

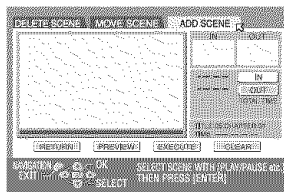
**3 Start playback.**

Press ▶ to start playback. The playback pictures appear in the window on the screen. The elapsed playing time starts counting with the arrow on “IN”.

- To locate the beginning of other titles, press ◀◀▶▶.

4 Set edit-in and edit-out points.

- 1 Find the point where you want the added scene to begin, then press **ENTER** with the arrow on “IN”. The edit-in time is fixed and the elapsed playing time starts counting again.
 - 2 Find the point where you want the added scene to end, then press **ENTER** with the arrow on “OUT”. The edit-out time is fixed.
- Press ◀◀, ▶▶, ▶▶▶, ◀◀◀, ▶▶▶▶ or || to find the edit-in and edit-out points.

5 Confirm the addition.

- 1 Press ◀▶ to move the arrow to “PREVIEW”, then press **ENTER** to preview approximately 5 seconds before and after the edited scene.
- 2 Press ◀▶ to select “EXECUTE”, then press **ENTER**.
 - The selected scene is added.

To modify the points

- 1 Press ◀▶ to move the arrow to “CLEAR”, then press **ENTER**.
- 2 Repeat step **3** – **5**.

6 Return to the normal screen.

Press **NAVIGATION**.

NOTE:

There may be a discrepancy of several seconds between the scene you intend to edit, and the scene which is actually edited.

Move scenes

Perform steps **1** to **3** of “Create Play List” (☞ pg. 78) before continuing.

1 Select a play list.

Press ◀▶ to move the arrow to a play list into which you wish to move a scene, then press ▽.

2 Access the Editing screen.

- 1 Press ◀▶ to move the arrow to “EDITING”, then press **ENTER**.
- 2 Press ◀▶ to move the arrow to “MOVE SCENE”.

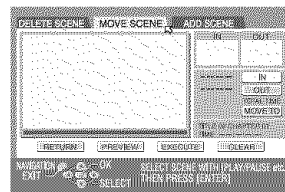
**3 Start playback.**

Press ▶ to start playback. The playback pictures appear in the window on the screen. The elapsed playing time starts counting with the arrow on “IN”.

- To locate the beginning of other titles, press ◀◀▶▶.

4 Set edit-in and edit-out points.

- 1 Find the point where you want the moved scene to begin, then press **ENTER** with the arrow on "IN". The edit-in time is fixed and the elapsed playing time starts counting again.
 - 2 Find the point where you want the moved scene to end, then press **ENTER** with the arrow on "OUT". The edit-out time is fixed.
 - 3 Press **▶** to start playback.
 - 4 Find the point where you want the moved scene to be moved, then press **ENTER** with the arrow on "MOVE TO".
- Press **◀◀, ▶, ▶▶, ◀◀, ▶▶** or **||** to find the edit-in, edit-out and move-to points.

5 Confirm the move.

- 1 Press **◀▷** to move the arrow to "PREVIEW", then press **ENTER** to preview the part approximately 5 seconds before and after the point to which the scene has been moved.
 - 2 Press **◀▷** to select "EXECUTE", then press **ENTER**.
- The selected scene is moved.

To modify the points

- 1 Press **◀▷** to move the arrow to "CLEAR", then press **ENTER**.
- 2 Repeat step **3** – **5**.

6 Return to the normal screen.

Press **NAVIGATION**.

NOTE:

There may be a discrepancy of several seconds between the scene you intend to edit, and the scene which is actually edited.

Delete unwanted part from play list

Perform steps **1** to **3** of "Create Play List" (pg. 78) before continuing.

1 Select a play list.

Press **◀▷** to move the arrow to a play list from which you wish to delete unwanted parts, then press **▽**.

2 Access the Editing screen.

- 1 Press **◀▷** to move the arrow to "EDITING", then press **ENTER**.
- 2 Press **◀▷** to move the arrow to "DELETE SCENE", then press **ENTER**.

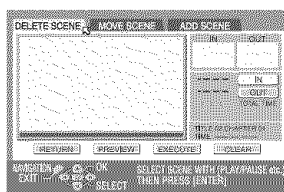

3 Start playback.

Press **▶** to start playback. The playback pictures appear in the window on the screen. The elapsed playing time starts counting with the arrow on "IN".

- To locate the beginning of other titles, press **◀◀/▶▶**.

4 Set edit-in and edit-out points.

- 1 Find the point where you want the deletion to begin, then press **ENTER** with the arrow on "IN". The edit-in time is fixed and the elapsed playing time starts counting again.
 - 2 Find the point where you want the deletion to end, then press **ENTER** with the arrow on "OUT". The edit-out time is fixed.
- Press **◀◀, ▶, ▶▶, ◀◀, ▶▶** or **||** to find the edit-in and edit-out points.

5 Confirm the deletion.

- 1 Press **◀▷** to move the arrow to "PREVIEW", then press **ENTER** to preview the scene approximately 5 seconds before and after the deleted part.
 - 2 Press **◀▷** to select "EXECUTE", then press **ENTER**.
- The selected scene is deleted.

To modify the points

- 1 Press **◀▷** to move the arrow to "CLEAR", then press **ENTER**.
- 2 Repeat steps **3** – **5**.

6 Return to the normal screen.

Press **NAVIGATION**.

NOTE:

There may be a discrepancy of several seconds between the scene you intend to edit, and the scene which is actually edited.

Play back play list

Perform steps **1** to **3** of “Create Play List” (☞ pg. 78) before continuing.

1 Select the play list(s).

Press ◀▶ to move the arrow on the index (small still pictures) of the desired play list.

- When you want the plural play lists to be played back continuously, press **MEMO** after selecting the desired play lists. The numbers of the playback order appear on the index. You can select up to 30 play lists.
- When you want to correct the order, move the arrow on the desired index and press **MEMO**. The number disappears and the unit re-numbers the other play lists automatically.
- When you want to cancel the order, press **■**.

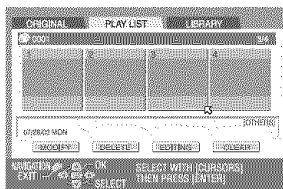

2 Start playback.

Press **ENTER**. Or simply press ▶. The playback starts.

3 Pause playback.

Press **II**.

- To resume normal playback, press ▶.

4 Stop playback.

Press **■**.

Delete play list

Perform steps **1** to **3** of “Create Play List” (☞ pg. 78) before continuing.

1 Select a play list.

- 1 Press ◀▶ to move the arrow to select one play list you want to delete, then press ▼.
- 2 Press ◀▶ to move the arrow to “DELETE”, then press **ENTER**.

2 Confirm the deletion.

Press ◀▶ to select “YES”, then press **ENTER**.

- When you cancel the deletion, select “NO”, then press **ENTER**.

3 Return to the normal screen.

Press **NAVIGATION**.

NOTE:

Even if a play list is deleted, the programs recorded on a DVD disc and the library information are not affected at all.

Modify Index

- 1 Perform steps **1** to **3** of “Create Play List” (☞ pg. 78).
- 2 Perform steps **3** to **6** of “Modify Index” (☞ pg. 75).

Modify Program Title

- 1 Perform steps **1** to **3** of “Create Play List” (☞ pg. 78).
- 2 Perform steps **1** to **5** of “Modify Program Name” (☞ pg. 76).

Modify Category

- 1 Perform steps **1** to **3** of “Create Play List” (☞ pg. 78).
- 2 Perform steps **1** to **4** of “Modify Category” (☞ pg. 76).

Modify Library Information



Program information can be registered in the unit's memory for up to 1,300 programs. It is helpful when finding out on which disc the desired program is recorded.

- Turn on the TV and select the AV mode.
- Slide the **TV/CABLE/DBS/DVD** switch to **DVD**.

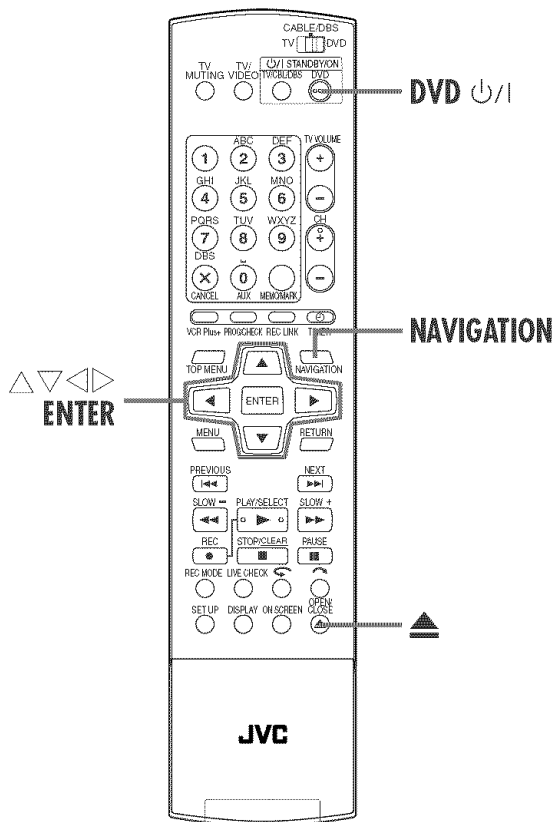

Scan for Program from library

1 Turn on the unit.

On the unit
Press **⏻**.

On the Remote
Press **DVD** **⏻**.

2 Access the library screen.

- 1 Press **NAVIGATION**. The Library Database DVD Navi screen appears.
- 2 Press **△▽◀▶** to move the arrow to "LIBRARY", then press **ENTER**.

3 Sort the information.

Press **◀▶** to move the arrow to the appropriate sort button to sort the information, then press **ENTER**.

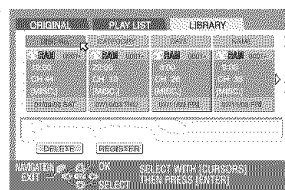

"DISC No.": Sort by disc number

"CATEGORY": Sort by category

"DATE": Sort by date

"NAME": Sort by name

- The sorting order can be switched between ascending order and descending order by pressing the sort buttons.

4 Select the program(s).

Press **◀▶** to move the arrow to select the desired program, then press **ENTER**.

- Playback begins automatically after the selected program is located.

When the disc that contains the selected program is not loaded

A screen prompting you to load the designated disc appears. Place the disc whose number is displayed on the screen after pressing **ENTER** to close the prompt screen. Then perform steps **2** to **4**.

5 Return to the normal screen.

Press **NAVIGATION**.

NOTE:

If a disc registered in the library is recorded or modified on DVD units from other manufacturers, it may become impossible to operate properly.

Register disc

1 Turn on the unit.

On the unit
Press O/I .

On the Remote
Press **DVD** O/I .

2 Load a disc.

- 1 Press \blacktriangle to open the disc tray.
- 2 Place a disc you want to register on the disc tray.
 - For details, refer to "Placing a Disc" (pg. 11).
- 3 Press \blacktriangle to close the disc tray.

3 Access the library screen.

- 1 Press **NAVIGATION**. The Library Database DVD Navi screen appears.
- 2 Press $\triangle \nabla \triangleleft \triangleright$ to move the arrow to "LIBRARY", then press **ENTER**.

4 Register the disc.

Press $\triangleleft \triangleright$ to move the arrow to "REGISTER", then press **ENTER**.

5 Confirm the registration.

Press $\triangleleft \triangleright$ to select "REGISTER", then press **ENTER**.

6 Return to the normal screen.

Press **NAVIGATION**.

NOTES:

- It is not possible to register discs used for On-Disc Timer Programming. (pg. 66)
- It is not possible to register discs formatted on devices other than JVC's DVD recorders.
- It is not possible to register discs recorded on devices other than JVC's DVD recorders.
- It is not possible to register discs when "SAVE AS LIBRARY" is set to "OFF" in FUNCTION SET UP menu. (pg. 98)

Delete information

1 Turn on the unit.

On the unit
Press O/I .

On the Remote
Press **DVD** O/I .

2 Access the library screen.

- 1 Press **NAVIGATION**. The Library Database DVD Navi screen appears.
- 2 Press $\triangle \nabla \triangleleft \triangleright$ to move the arrow to "LIBRARY", then press **ENTER**.

3 Select a program.

- 1 Press $\triangle \nabla \triangleleft \triangleright$ to move the arrow to the appropriate sort button to sort the information, then press **ENTER**.
- 2 Press $\triangleleft \triangleright$ to move the arrow to a program you want to delete, then press ∇ .

4 Delete the program.

Press $\triangle \nabla \triangleleft \triangleright$ to move the arrow to "DELETE", then press **ENTER**.

5 Confirm the deletion.

Press $\triangleleft \triangleright$ to select "DELETE", then press **ENTER**.

6 Return to the normal screen.

Press **NAVIGATION**.

Playback with MP3/JPEG Navigation



This unit can play back discs that MP3 sound files and JPEG image files taken with digital still cameras or other devices are recorded. The MP3/JPEG Navigation enables you to search and select the desired files recorded on CD-R/RW or CD-ROM discs very easily.

The following screen appears as the MP3/JPEG Navigation screen when you press **NAVIGATION**. You can move the arrow to select the desired position on the screen by pressing Δ ∇ \triangleleft \triangleright on the Remote.

1 Name of the inserted disc.
 2 Sort buttons ("MP3"/"JPEG")
 3 Selected group number/total number of groups on the disc
 4 Group name
 5 Return button ("RETURN")
 6 Group name/Created date
 7 File type indicator
 ♪: MP3
 📷: JPEG
 8 Selected file
 9 Selected file number/total number of files in the group that contains the selected file
 10 Program number/file name

Locating the desired group and tracks

1 Load a disc.

- 1 Press ▲ to open the disc tray.
- 2 Place a disc on the disc tray.
 - For details, refer to “Placing a Disc” (☞ pg. 11).
- 3 Press ▲ to close the disc tray.

2 Access the MP3/JPEG Navigation screen.

Press **NAVIGATION**. The MP3/JPEG Navigation screen appears.

3 Display the item.

For MP3 Playback

Press ◀▶ to move the arrow to “MP3”.

- Only groups which contain MP3 files appear.

For JPEG Playback

Press ◀▶ to move the arrow to “JPEG”.

- Only groups which contain JPEG files appear.

4 Select the group.

Press ◀▶ to move the arrow to the desired group, then press **ENTER**.

For MP3 Playback

- The tracks in the selected group appear.

For JPEG Playback

- The images in the selected group appear.

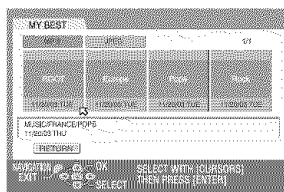

5 Select the item.

Press ▲▼◀▶ to move the arrow to the desired item, then press **ENTER**. The unit starts playback from the selected item.

- The unit stops when all items in the selected group are played back.

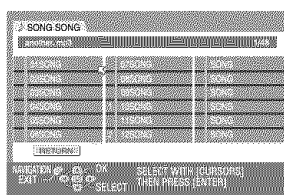

NOTES:

- If you press ► instead of **ENTER** in step 4, the unit starts playback from the first file of the group.
- JPEG files are played back as a slide show at the set intervals. (☞ pg. 52, “Select the switching interval of the slide show”)
- If a file name includes any 2-byte character, the unit may not show the file name correctly.
- Press ▲▼ to move the arrow to “RETURN”, then press **ENTER** to return to the screen that shows the group(s).
- The order of the groups and items shown in step 4 and 5 may differ from the order shown on your PC.

Program Playback

Perform steps 1 to 4 of “Locating the desired group and tracks” in the left column before continuing.

1 Select the items in the desired order.

Press ▲▼◀▶ to move the arrow to the desired item, then press **MEMO**.

- The order number appears on the left of the track name.
- Repeat this step as necessary.
- To cancel the track, press ▲▼◀▶ to move the arrow to the track, then press ✕.
- Pressing ■ clears all the order numbers.

2 Start playback.

Press ►.

- To quit the Program Playback, press ■.
- Repeat playback can be performed if it is set as such in Play Set Up menu. (☞ pg. 48, “Repeat Playback”)

NOTES:

- It is not possible to select tracks and images simultaneously.
- It is not possible to select tracks or images in other groups.

On completion of the playback of all the items

- 1 Perform steps 1 to 4 of “Locating the desired group and tracks” in the left column.
- 2 Press ■.
- The order numbers are reset and cleared.
- 3 Press **NAVIGATION** to complete the procedure.

DV Dubbing

You can dub programs from a camcorder or DV equipment connected to the unit with a DV cable. The unit's Remote allows you the limited control of the connected camcorder or DV equipment functions during dubbing.

NOTE:

When you connect a PC to the DV IN connector, we do not assure the normal operation of this unit.

Your unit

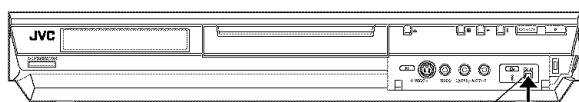

DV IN connector

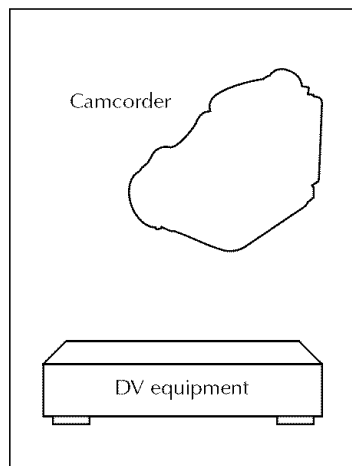

DV cable
(not supplied)
DV connector

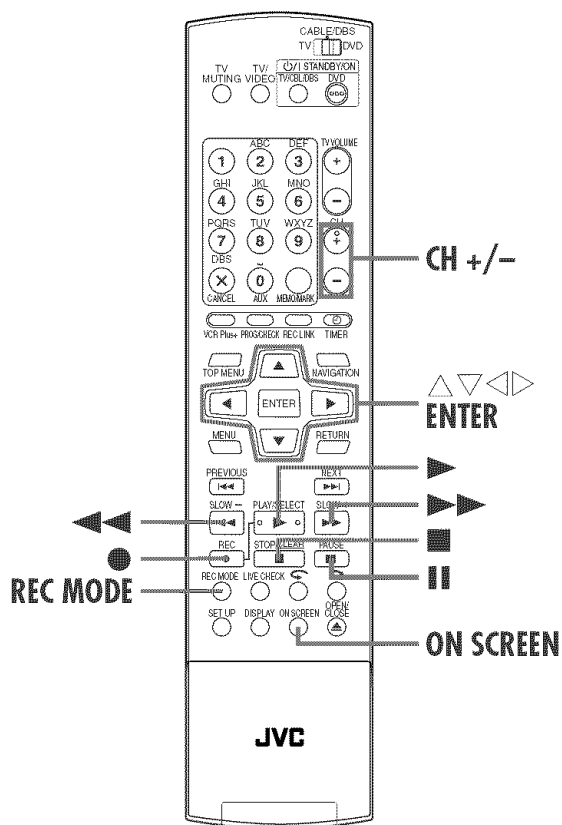

1 Make connections.

Connect a camcorder or DV equipment to the DV IN connector on the unit's front panel.

2 Prepare the unit for dubbing.

1 Load a DVD-RAM/RW/R disc on the unit.

2 Press **CH +/-** to set the channel to "DV DUBBING".

• The "DV DUBBING" controller appears on the TV screen.

• If "**⏮**" does not appear on the "DV DUBBING" controller, make sure the DV equipment is connected correctly.

3 Press **<>** to move **↔** to **⏮/⏭**, then press **ENTER**.

4 Press **△▽** repeatedly to select the desired sound track, then press **ENTER**.

5 Press **REC MODE** repeatedly until the desired recording speed appears. (☞ pg. 58, "Recording Speed")

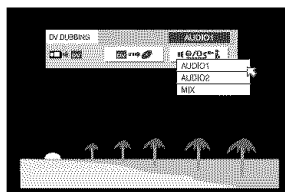

3 Prepare the DV equipment for dubbing.

Locate the point from where you want to start dubbing, then stop or pause playback by pressing the following buttons on the Remote:



• To play back in slow speed (1/10 of the normal speed), press **⏮** to pause playback, then press **⏮** or **⏭**.

• To play back frame-by-frame, press **⏮** to pause playback, then press **⏮** repeatedly. Each press of **⏮** advances a frame.

• To change the playback direction, press **⏮** or **⏭**.

4 Start dubbing.

Press **<>** to move the arrow to **⏮/⏭**, then press **ENTER**.

• Playback on the external DV equipment and recording on the unit should start simultaneously.

• When the playback from the beginning is not possible, the "DV DUBBING" controller cannot be used. Perform dubbing without using the "DV DUBBING" controller. (☞ right column)

• To pause dubbing, press **<>** to move **↔** to **⏮/⏭**, then press **ENTER**. Both the unit and the external DV equipment pause dubbing. Pressing **⏮** on the unit also works the same way.

• To clear the "DV DUBBING" controller from the TV screen, press **ON SCREEN**.

5 Stop dubbing.

Press **■** on the Remote.

• Both the unit and the external DV equipment stop dubbing.

NOTES:

- Dubbing copyright guarded programs is not possible.
- Original DV informations such as the recording date and time are not recorded.
- The superimposed indication during the operation or dubbing is not recorded.
- Only DV format image can be dubbed; MPEG2 format image cannot be dubbed.

Performing dubbing without using the "DV DUBBING" controller

- 1 Press **CH +/-** to set the channel to "DV DUBBING".
- 2 Press **REC MODE** repeatedly until the desired recording speed appears.
- 3 Start playback on the external DV equipment slightly before the actual point from where you wish to start dubbing.
- 4 Press and hold **●**, then press **▶** on the Remote, or press **●** on the unit.
 - Dubbing starts.
- 5 When the dubbing ends, press **■** on the unit, then stop playback on the external DV equipment.

Edit From A Camcorder

You can use a camcorder as the source player and your unit as the recording deck.

Slide the **TV/CABLE/DBS/DVD** switch to **DVD**.

1 Make connections.

- 1 If the camcorder has no S-VIDEO output connector:
 - connect the camcorder's AUDIO OUTPUT and VIDEO OUT connectors to the unit's AUDIO and VIDEO input connectors on the front panel.
 - 2 If the camcorder has an S-VIDEO output connector:
 - connect the camcorder's AUDIO OUTPUT and S-VIDEO OUT connectors to the unit's AUDIO and S-VIDEO input connectors on the front panel.
- When using a monaural camcorder, connect its AUDIO OUTPUT connector to the AUDIO L input connector on your unit.

2 Set the unit's input mode.

Press **CH +/-** to set the channel to "F-1".

- When using S-VIDEO connector, set "FRONT AUX F-1" to "S-VIDEO". (☞ pg. 98)
- When using VIDEO connector, set "FRONT AUX F-1" to "VIDEO". (☞ pg. 98)

3 Set the recording speed.

Press **REC MODE** repeatedly until the desired recording speed appears.

4 Prepare the camcorder for dubbing.

Start playback on the camcorder slightly before the actual point from where you wish to start dubbing.

5 Start dubbing.

Press and hold **●**, then press **▶** on the Remote, or press **●** on the unit.

6 Stop dubbing.

Press **■** on the unit, then stop playback on the camcorder.

NOTES:

- All necessary cables can be obtained from your dealer.
- Refer to the camcorder's instruction manual for operating procedure.
- The quality of dubbed picture becomes poorer than that of the original.

1 If the camcorder has no S-VIDEO output connector:

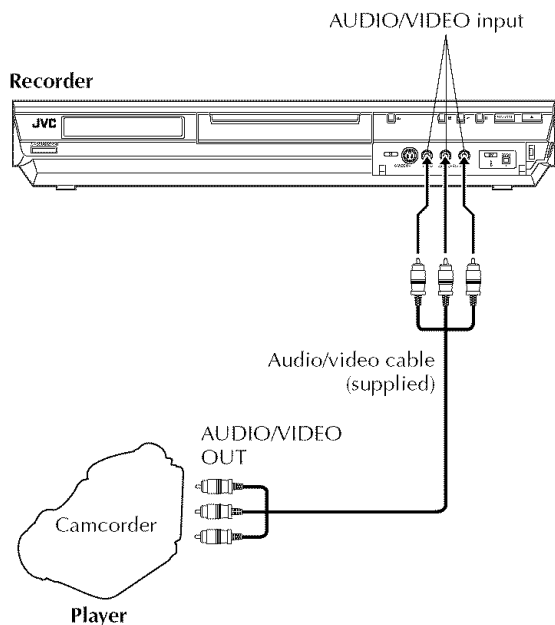

2 If the camcorder has an S-VIDEO output connector:

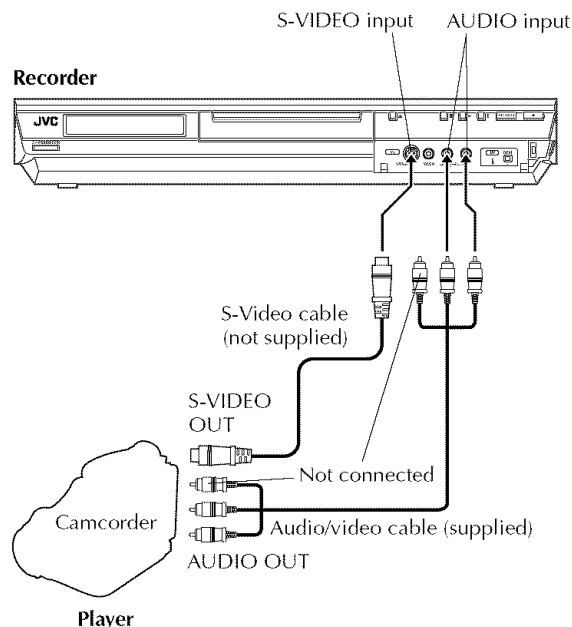

Edit To Or From Another Recorder

You can use your unit as the source player or as the recording deck.

Slide the **TV/CABLE/DBS/DVD** switch to **DVD**.

1 Make connections.

1 When using your unit as the source player ... connect its AUDIO/VIDEO or AUDIO/S-VIDEO OUTPUT connectors to the audio/video or audio/S-video input connectors on another recorder.

2 When using your unit as the recording deck ... connect its AUDIO/VIDEO or AUDIO/S-VIDEO INPUT connectors to the audio/video or audio/S-video output connectors on another recorder.

- If connecting a unit with an S-VIDEO input/output connector, it is recommended to use an optional S-Video cable to minimize picture degradation while editing.

2 Set the input mode of recording deck.

With this video unit, press **CH +/-** to select "L-1" or "L-2" depending on the connectors being used.

- When using S VIDEO connector, set "REAR AUX L-1" or "REAR AUX L-2" to "S-VIDEO". (☞ pg. 98)
- When using VIDEO connector, set "REAR AUX L-1" or "REAR AUX L-2" to "VIDEO". (☞ pg. 98)
- When using another recorder as the recording deck, refer to its instruction manual.

3 Set the recording speed.

Press **REC MODE** repeatedly until the desired recording speed appears.

4 Start the source player.

Engage the Play mode of the source player.

5 Start the recording deck.

Engage the Record mode of the recording deck.

6 Stop dubbing.

Stop recording on the recording deck, then stop playback on the source player.

NOTES:

- All necessary cables can be obtained from your dealer.
- When you use this unit as the source player for editing, be sure to set "SUPERIMPOSE" to "OFF" before starting. (☞ pg. 99)

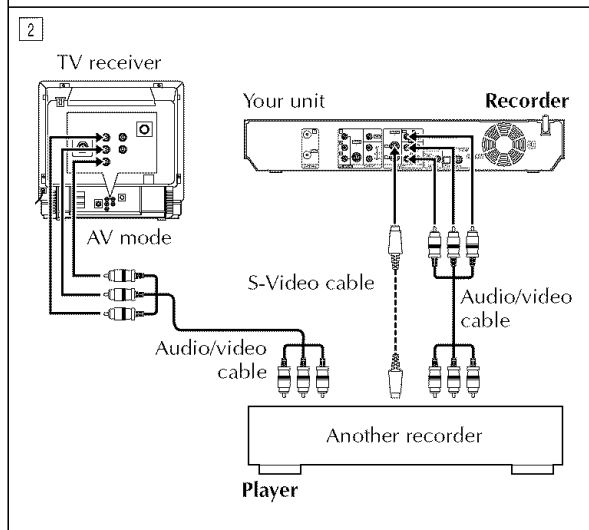
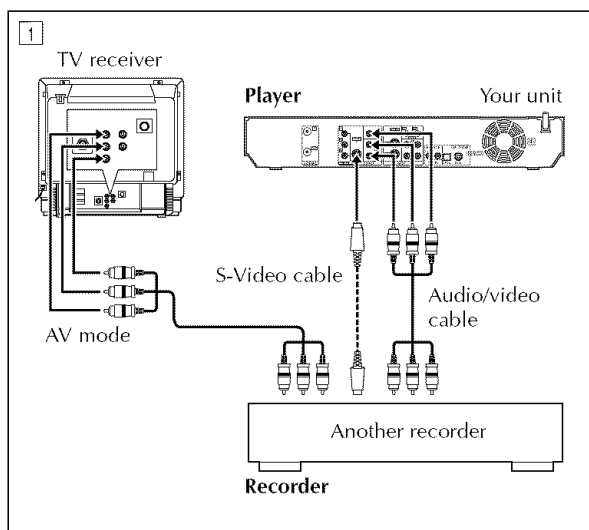

Digital Audio Dubbing

- Turn on the TV and select the AV mode.
- Slide the TV/CABLE/DBS/DVD switch to DVD.

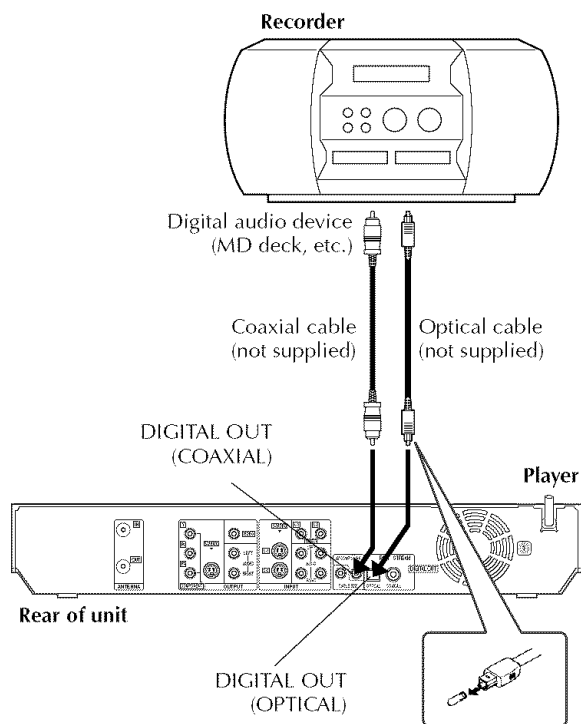

Note for connection:
Remove the protection cap from the cable.

You can dub selected audio from a DVD or Audio CD disc to a digital audio device. However, it is not possible to dub copy-protected discs.

Example: Dubbing to an MD

1 Make connections.

Connect the unit and a digital audio device using either an optional optical cable or an optional coaxial cable.

2 Place a disc and load an MD.

For the unit

- 1 Press to open the disc tray.
- 2 Place a disc on the disc tray.
- 3 Press to close the disc tray.

For the digital audio device

Load an MD.

3 Prepare the unit for dubbing.

- 1 Select the audio to be dubbed.
- 2 Start playback slightly before the actual point from where you wish to start dubbing.
- 3 Press to pause playback.

4 Prepare the digital audio device for dubbing.

Select the input mode.

5 Start dubbing.

- 1 Press to start playback on the unit.
- 2 Start recording on the digital audio device.

6 Stop dubbing.

Stop recording on the digital audio device. Then press to stop playback on the unit.

NOTE:

There may be a discrepancy of several seconds between where you intend editing to start, and where it actually starts.

Remote Control Functions

Remote 1/2/3/4 Code Switching

The Remote is capable of controlling four JVC video units independently. Each of the units can respond to one of four codes (1, 2, 3 or 4). The Remote is preset to send 3 code signals because your unit is initially set to respond to 3 code signals. You can easily modify your unit to respond to 1, 2 or 4 code signals.

Slide the TV/CABLE/DBS/DVD switch to DVD.

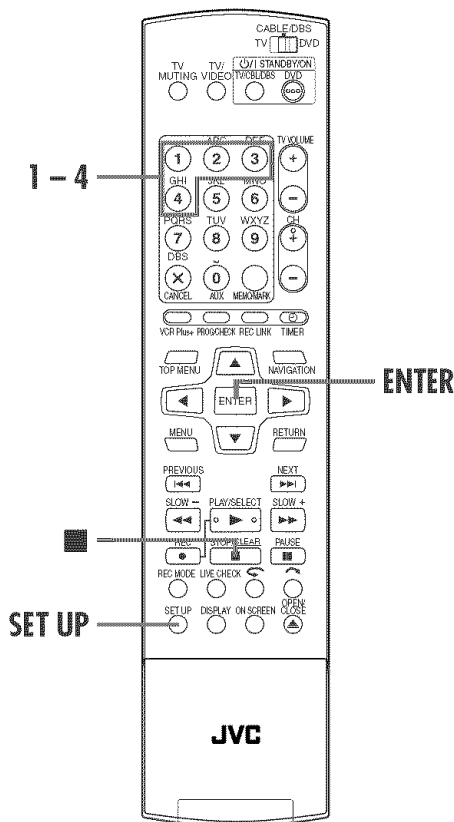
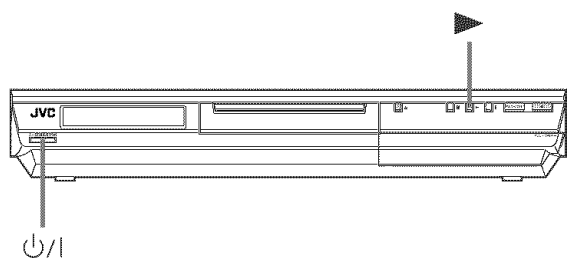

On the Remote

Keep pressing **SET UP** down during steps 1 – 2.

1 Change the remote control code.

Press the number key “1” for 1, “2” for 2, “3” for 3 or “4” for 4.

2 Set the remote control code.

Press **ENTER** to set the code.

On the unit

3 Turn off the unit.

Press **⏻** on the unit.

4 Display the code.

Press **▶** on the unit for over 5 seconds while the unit is turned off.

- The code currently set appears on the front display panel.

5 Change the unit’s code.

Press **■** on the Remote.

- The code currently set on the Remote blinks on the front display panel for approximately 5 seconds, and is applied to the unit.

NOTE:

When “POWER SAVE” is set to “ON” (pg. 99), it is not possible to change the remote code.

TV Multi-Brand Remote Control

Your Remote can operate the basic functions of your TV set. In addition to JVC TVs, other manufacturer's TVs can also be controlled.

Before performing the following steps:

- Turn off the TV using its Remote.
- Slide the TV/CABLE/DBS/DVD switch to TV.

1 Set the TV brand code.

Keep pressing **SET UP** down during step 1. Enter your TV's brand code using the **number keys**, then press **ENTER**.

Press **TV/CBL/DBS** $\phi/|$ on the unit's Remote to turn on the TV and try operations (step 2).

- Once you have set the Remote to operate the TV, you do not have to repeat this step until you replace your Remote's batteries.
- Some brands of TVs have more than one code. If the TV does not function with one code, try entering another.

2 Operate the TV.

Press the corresponding button: **TV/CBL/DBS** $\phi/|$, **TV/VIDEO**, **CH +/-**, **TV VOLUME +/-**, **TV MUTING**, **number keys**.

- For some brands of TVs, you must press **ENTER** after having pressed the **number keys**.

BRAND NAME	CODE
JVC	01, 03
HITACHI	10
MAGNAVOX	02
MITSUBISHI	03
PANASONIC	04, 11
RCA	05
SHARP	06
SONY	07
SAMSUNG	12
SANYO	13
SEARS	13
TOSHIBA	08
ZENITH	09

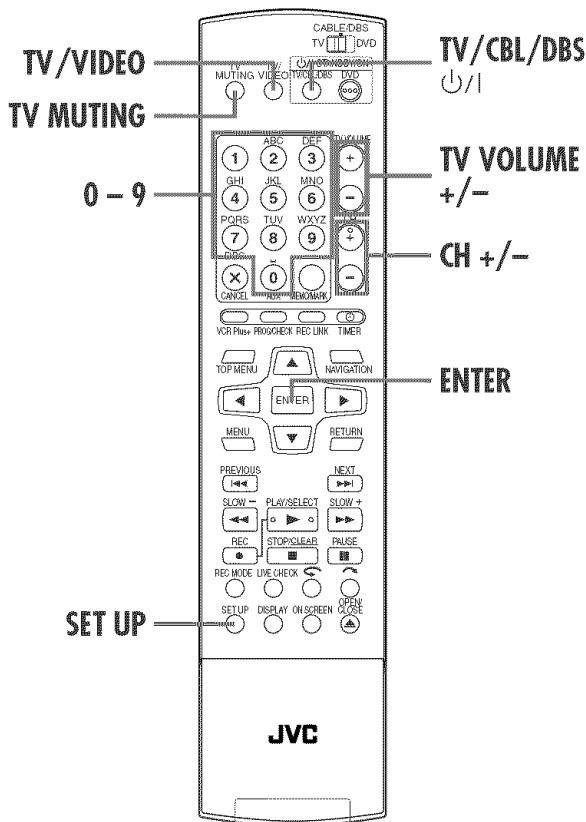

IMPORTANT:

Although the supplied Remote unit is compatible with JVC televisions, as well as many other models, it may not work with your TV, or in some instances, may have limited function capability.

Cable Box Multi-Brand Remote Control

Your Remote can operate the basic functions of your cable box set. In addition to JVC cable boxes, other manufacturer's cable boxes can also be controlled.

Slide the **TV/CABLE/DBS/DVD** switch to **CABLE/DBS**.

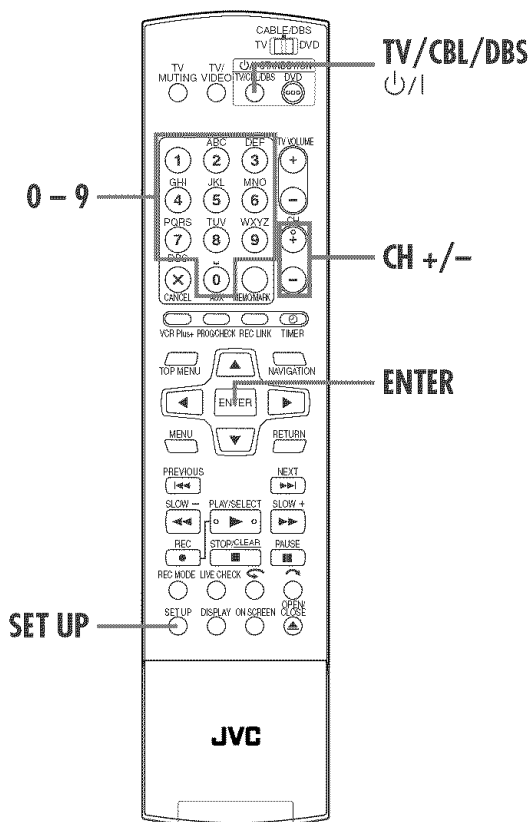

IMPORTANT:

It may not work with your cable box, or in some instances, may have limited function capability.

NOTES:

- You must set the cable box brand for your Remote and the cable box brand for your Controller (pg. 29) separately. The list of cable box brands that can be controlled by your Remote is different from the list of brands that can be controlled by your controller.
- It's not possible to set the Remote for both your cable box and a DBS receiver at the same time. You can only set the Remote to operate one of these units at a time.

1 Set the cable box brand code.

Keep pressing **SET UP** down during step 1. Enter your cable box's brand code using the **number keys**, then press **ENTER**.

Press **TV/CBL/DBS** on the unit's Remote to turn on the cable box and try operations (step 2).

- Once you have set the Remote to operate the cable box, you do not have to repeat this step until you replace your Remote's batteries.
- Some brands of cable box have more than one code. If the cable box does not function with one code, try entering another.

2 Operate the cable box.

Press the corresponding button: **TV/CBL/DBS**, **CH +/-**, **number keys**.

- For some brands of cable box, you must press **ENTER** after having pressed the **number keys**.
- The **number keys** may not function with some cable boxes.

BRAND NAME	CODE
ARCHER	01, 05, 17
CABLETENNA	01, 17
CABLEVIEW	15, 16, 17, 21, 25
CITIZEN	15, 16, 17, 21, 25
CURTIS	02
DIAMOND	01, 17
GC BRAND	15, 16, 17, 21, 25
GEMINI	15
GENERAL INSTRUMENTS	01, 04, 06, 11, 12, 15, 28
HAMLIN	10, 18, 23
JASCO	15
JERROLD	01, 04, 06, 11, 12, 15, 28
NOVAVISION	02
OAK	07
PANASONIC	13, 14
PULSER	15, 16, 17, 21, 25
RCA	13, 14
REGAL	10, 18, 23
REMBRANDT	01, 16, 17
SAMSUNG	05, 16, 24
SCIENTIFIC ATLANTA	02
SIGMA	07
SL MARX	05, 16, 17, 24, 25
SPRUCER	13, 14
STARGATE	05, 15, 16, 17, 21, 24, 25
TELEVIEW	05, 16, 24
TOCOM	01, 04, 16
UNIKA	01, 17
UNIVERSAL	16, 17, 25
VIDEOWAY	03, 09, 22
ZENITH	03, 09, 22

DBS Receiver Multi-Brand Remote Control

Your Remote can operate the basic functions of your DBS (Direct Broadcast Satellite) receiver set. In addition to JVC DBS receivers, other manufacturer's DBS receivers can also be controlled.

Slide the **TV/CABLE/DBS/DVD** switch to **CABLE/DBS**.

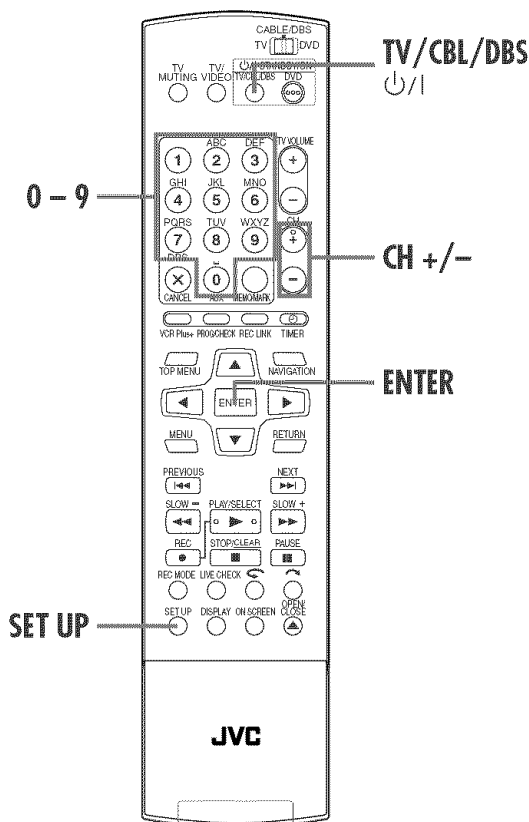

1 Set the DBS receiver brand code.

Keep pressing **SET UP** down during step **1**. Enter your DBS receiver's brand code using the **number keys**, then press **ENTER**.

Press **TV/CBL/DBS** \updownarrow on the unit's Remote to turn on the DBS receiver and try operations (see step **2**).

- Once you have set the Remote to operate the DBS receiver, you do not have to repeat this step until you replace your Remote's batteries.
- Some brands of DBS receiver have more than one code. If the DBS receiver does not function with one code, try entering another.

2 Operate the DBS receiver.

Press the corresponding button: **TV/CBL/DBS** \updownarrow , **CH +/-**, **number keys**.

- For some brands of DBS receiver, you must press **ENTER** after having pressed the **number keys**.
- The **number keys** may not function with some DBS receivers.

BRAND NAME	CODE
JVC (DISH Network)	51
ECHOSTAR (DISH Network)	51
SONY (DSS)	41
RCA (DSS)	40

NOTES:

- You must set the DBS receiver brand for your Remote and the DBS receiver brand for your Controller (see pg. 32) separately.
- It's not possible to operate a DBS receiver that is not equipped with a remote sensor.
- It's not possible to set the Remote for both your DBS receiver and a cable box at the same time. You can only set the Remote to operate one of these units at a time.

IMPORTANT:

Although the supplied Remote unit is compatible with JVC DBS receivers, as well as many other models, it may not work with your DBS receiver, or in some instances, may have limited function capability.

Connecting To A Dolby Digital Decoder or An Amplifier With Built-in DTS

These instructions enable you to connect your unit to a Dolby Digital decoder or an amplifier with built-in DTS.

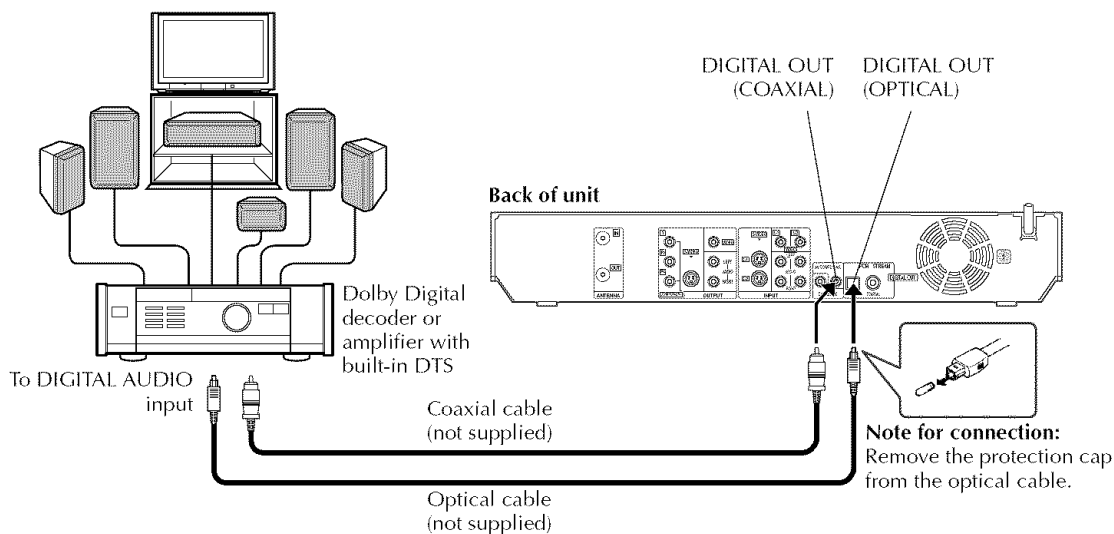

Make connections.

Connect the unit and a Dolby Digital decoder or an amplifier with built-in DTS using either an optional optical cable or an optional coaxial cable.

NOTES:

- For Dolby Digital sound, set "DIGITAL AUDIO OUT" to "DOLBY DIGITAL/PCM". (☞ pg. 97)
- For DTS sound, set "DIGITAL AUDIO OUT" to "STREAM/PCM". (☞ pg. 97)

CAUTIONS:

- This unit has a dynamic range of more than 110 dB with regards to its Hi-Fi audio capability. It is recommended that you check the maximum level if you are going to listen to the Hi-Fi audio signals through a stereo amplifier. A sudden surge in the input level to the speakers may damage them.
- Some speakers and televisions are specially shielded to prevent television interference. If both are of the non-shielded type, do not place the speakers adjacent to the TV set as this can adversely affect the playback picture.

Mode Set

- Turn on the unit.
- Turn on the TV and select the AV mode.
- Slide the TV/CABLE/DBS/DVD switch to DVD.

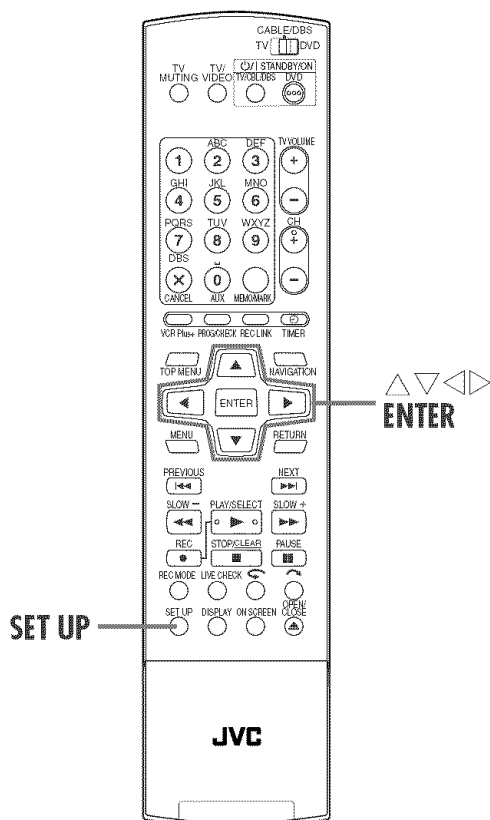

Various modes of this unit are categorized into menus nested in 2 levels shown in the following table. To change the settings of these modes, find the desired mode in the menu (for details on each menu, see pages 97 through 100), then follow the procedure below.

DVD SET UP	LANGUAGE SET (☞ pg. 22) AUDIO OUTPUT (☞ pg. 97) UTILITY (☞ pg. 53, 101, 102)
FUNCTION SET UP	VIDEO IN/OUT (☞ pg. 28, 98) RECORDING SET (☞ pg. 98) DISPLAY SET (☞ pg. 99) OTHERS (☞ pg. 100)
INITIAL SET UP	TUNER SET (☞ pg. 26) STB SET (☞ pg. 30, 33) CLOCK SET (☞ pg. 24)

- The procedure below shows how to set the desired option of the "2ND AUDIO REC." mode as an example.

1 Access the Main Menu screen.

Press SET UP.

2 Access the "RECORDING SET" screen.

- 1 Press $\triangleleft \triangleright$ to select "FUNCTION SET UP", then press ENTER.
- 2 Press $\triangleleft \triangleright$ to select "RECORDING SET", then press ENTER.

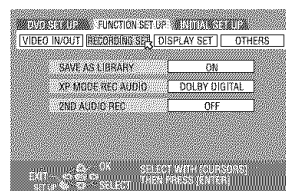

3 Select the desired option.

- 1 Press $\triangle \nabla$ to select "2ND AUDIO REC.", then press ENTER.
- 2 Press $\triangle \nabla$ to select the desired option, then press ENTER.

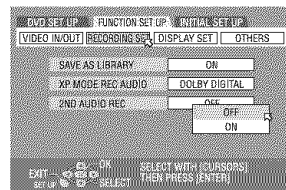

4 Complete the setting.

Press SET UP.

AUDIO OUTPUT

(The **boldface** settings in the table below indicate the settings at your purchase.)

<p>■ DIGITAL AUDIO OUT DOLBY DIGITAL/PCM STREAM/PCM PCM ONLY</p>	<p>Set to the appropriate mode according to the type of the device connected to DIGITAL OUT connector.</p> <p>DOLBY DIGITAL/PCM: Select this when you connect the digital input connector of a Dolby Digital decoder or an amplifier with a built-in Dolby Digital decoder.</p> <p>STREAM/PCM: Select this when you connect the digital input connector of an amplifier with a built-in DTS, Dolby Digital, or MPEG multichannel decoder.</p> <p>PCM ONLY: Select this when you connect the linear PCM digital input of other audio equipment (amplifier, MD or DAT deck, etc.).</p>
<p>■ ANALOG AUDIO OUT STEREO DOLBY SURROUND</p>	<p>Select the appropriate setting to accommodate the unit to the connected A/V equipment. This function takes effect when a DVD VIDEO disc is played back.</p> <p>STEREO: Select this when listening to conventional two-channel stereo audio with the unit's AUDIO OUTPUT connectors connected to a stereo amplifier/receiver or TV set, or in case you want to record the audio from a DVD VIDEO disc to a Mini Disc, etc.</p> <p>DOLBY SURROUND: Select this when listening to multichannel surround audio with the unit's AUDIO OUTPUT connectors connected to an amplifier/receiver with a built-in surround decoder or a surround decoder.</p>
<p>■ D. RANGE CONTROL NORMAL WIDE RANGE TV MODE</p>	<p>The dynamic range (the difference between the loudest sound and the quietest one) can be compressed during playback of a program encoded in Dolby Digital format.</p> <p>This function takes effect when a DVD VIDEO disc recorded in Dolby Digital format is played back at low or middle volume.</p> <p>NORMAL: Normally select this setting to activate this function.</p> <p>WIDE RANGE: Select this to deactivate this function when you enjoy wide dynamic range program.</p> <p>TV MODE: Select this when you hear the sound through the TV's speaker(s).</p> <p>NOTES:</p> <ul style="list-style-type: none"> ● This function takes no effect on programs other than that recorded in Dolby Digital format. ● This function dose not work when Simulated Surround Effect is activated. (☞ pg. 50) ● The effect of "NORMAL" and "WIDE RANGE" may not be different depending on discs.
<p>■ OUTPUT LEVEL STANDARD LOW</p>	<p>You can lower the output level of analog audio to accommodate the unit to the connected A/V equipment.</p> <p>STANDARD: Normally select this setting.</p> <p>LOW: The output level of analog audio is lowered.</p>

VIDEO IN/OUT

(The **boldface** settings in the table below indicate the settings at your purchase.)

<p>■ FRONT AUX F-1 VIDEO S-VIDEO</p>	<p>Select the appropriate mode depending on the connector (F-1) being used on the front panel.</p> <p>VIDEO: To use the VIDEO input connector on the front panel. S-VIDEO: To use the S-VIDEO input connector on the front panel.</p>
<p>■ REAR AUX L-1 VIDEO S-VIDEO</p>	<p>Select the appropriate mode depending on the connector (L-1) being used on the rear panel.</p> <p>VIDEO: To use the VIDEO input connector on the rear panel. S-VIDEO: To use the S-VIDEO input connector on the rear panel.</p>
<p>■ REAR AUX L-2 VIDEO S-VIDEO</p>	<p>Select the appropriate mode depending on the connector (L-2) being used on the rear panel.</p> <p>VIDEO: To use the VIDEO input connector on the rear panel. S-VIDEO: To use the S-VIDEO input connector on the rear panel.</p>

RECORDING SET

(The **boldface** settings in the table below indicate the settings at your purchase.)

<p>■ SAVE AS LIBRARY OFF ON</p>	<p>When this function is set to "ON", the recording information is automatically stored in the library. For details, refer to "Modify Library Information" (pg. 82).</p>
<p>■ XP MODE REC AUDIO DOLBY DIGITAL LINEAR PCM</p>	<p>You can select the audio format when you record a program in XP mode. When this function is set to "LINEAR PCM", you can obtain a high-quality audio sound.</p> <p>DOLBY DIGITAL: To record in Dolby Digital format. LINEAR PCM: To record in Linear PCM format.</p>
<p>■ 2ND AUDIO RECORD ON OFF</p>	<ul style="list-style-type: none"> ● When this function is set to "ON"; If a SAP program is received, the SAP audio is recorded on L/R tracks. The main audio is not recorded. If a non-SAP program is received, the main audio is recorded on L/R tracks. ● When this function is set to "OFF", the SAP audio cannot be recorded. <p>NOTES: When the channel is changed on the unit;</p> <ul style="list-style-type: none"> ● The "MONO" indicator appears on the screen for about 5 seconds if the program is a monoral broadcast. ● The "STEREO" indicator appears on the screen for about 5 seconds if the program is a stereo broadcast. ● Both "STEREO" and "SAP" indicators appear when a stereo program is accompanied by SAP sound. ● Both "MONO" and "SAP" indicators appear when the main audio on the monoral broadcast is accompanied by SAP sound.

DISPLAY SET

(The **boldface** settings in the table below indicate the settings at your purchase.)

<p>■ SUPERIMPOSE OFF AUTO</p>	<p>When "SUPERIMPOSE" is set to "AUTO" and ON SCREEN on the Remote is pressed, various operational indicators appear on the TV screen. To clear the operational indicators, press ON SCREEN again. You can select the modes of indications superimposed on the TV screen.</p> <p>OFF: To turn off superimposed indications.</p> <p>AUTO: To superimpose operational indications for approximately five seconds just after the corresponding operation.</p> <p>NOTES:</p> <ul style="list-style-type: none"> • When you use this unit as the source player for editing, be sure to set "SUPERIMPOSE" to "OFF" before starting. (☞ pg. 89, "Edit To Or From Another Recorder") • When you select "AUTO", during playback, the operation mode indicators may be disturbed depending on the type of disc being used.
<p>■ GRAY BACK OFF ON</p>	<p>When this function is set to "ON", the TV screen becomes all grey when receiving a channel not in use.</p> <p>NOTE: When you want to receive an unstable channel with poor signals, set this function to "OFF".</p>
<p>■ DIMMER BRIGHT DIMMED1 DIMMED2 OFF</p>	<p>You can change the brightness of the front display panel.</p> <p>BRIGHT: Normally select this.</p> <p>DIMMED1/DIMMED2: To change the brightness level. (Blue lamp on the front display panel become dimmer.)</p> <p>OFF: To dim the front display panel. (Blue lamp on the front display panel is turned off.)</p> <p>NOTE: It is impossible to turn off the light of the front display completely. When "BRIGHT" or "DIMMED1" is selected, the brightness level will be same as "DIMMED1" after the unit is turned off. When "DIMMED2" or "OFF" is selected, the brightness level will be same as "DIMMED2" after the unit is turned off.</p>
<p>■ POWER SAVE OFF ON</p>	<p>When this function is set to "ON", you can reduce the power consumption while the unit is turned off.</p> <p>NOTES:</p> <ul style="list-style-type: none"> • During Power Save mode — — the front display panel will be turned off. — the Just Clock function does not work. • Power Save does not work when — — the unit is in the Timer mode. — the unit's power is turned off after timer-recording or Instant Timer Recording. — the Satellite Auto Recording mode is engaged. (☞ pg. 71) • It takes some time for the unit to complete initialisation after you turn on unit power, with "WAKE UP" blinking on the front display panel.
<p>■ ON SCREEN LANGUAGE</p>	<p>This unit offers you the choice to view on-screen messages in 3 different languages. For details, refer to "On-screen Language Set" (☞ pg. 22).</p>

OTHERS

(The **boldface** settings in the table below indicate the settings at your purchase.)

<p>■ AUTO TIMER OFF ON</p>	<p>When this function is set to “ON”, the timer is automatically engaged when the unit power is turned off, and automatically disengaged when the unit is powered back on.</p> <p>NOTE: For safety, when “AUTO TIMER” is set to “OFF”, all other functions are disabled while the Timer mode is engaged. To disengage the timer, press ⊖ (TIMER).</p>
<p>■ RESUME ON OFF DISC RESUME</p>	<p>When this function is set to “ON” or “DISC RESUME”, you can use the resume function. (☞ pg. 37)</p> <p>ON: You can start playback from the resume point of the placed disc.</p> <p>OFF: You cannot use the resume function.</p> <p>DISC RESUME: The unit retains a memory of the resume points of the last 30 discs played back, even though they have been ejected.</p> <p>NOTE: “DISC RESUME” setting works on DVD VIDEO, VCD, SVCD and already finalised DVD-R/DVD-RW (video mode) discs. For other types of discs, the function under “ON” setting will be applied even if “RESUME” is set to “DISC RESUME”.</p>
<p>■ AV COMPULINK MODE DVD1 DVD2 DVD3</p>	<p>By connecting other JVC's AV COMPULINK components, one touch control of the audio and video components linked via their AV COMPULINK connectors become possible. Select the appropriate mode depending on the used connector of the connected AV COMPULINK components.</p> <p>DVD1: Select this when connecting to the TV's VIDEO Input 3 or AV amplifier's DVD Input connector.</p> <p>DVD2: Select this when connecting to the TV's VIDEO Input 1 connector.</p> <p>DVD3: Select this when connecting to the TV's VIDEO Input 2 connector.</p> <p>NOTE: Refer to the other components' instruction manuals for connection and its operation.</p>

Format a disc



Some DVD-RAM/RW discs are unformatted. Format the disc when you use an unformatted disc or you want to delete all recordings and data on the disc.

ATTENTION:

- When a disc is formatted, all recordings and data are erased. It is impossible to restore them.
- Never turn off the unit or disconnect the mains power cord while "NOW FORMATTING..." is displayed on the TV screen.

- Turn on the unit.
- Turn on the TV and select the AV mode.
- Slide the TV/CABLE/DBS/DVD switch to DVD.
- Load a DVD-RAM/RW disc to format.

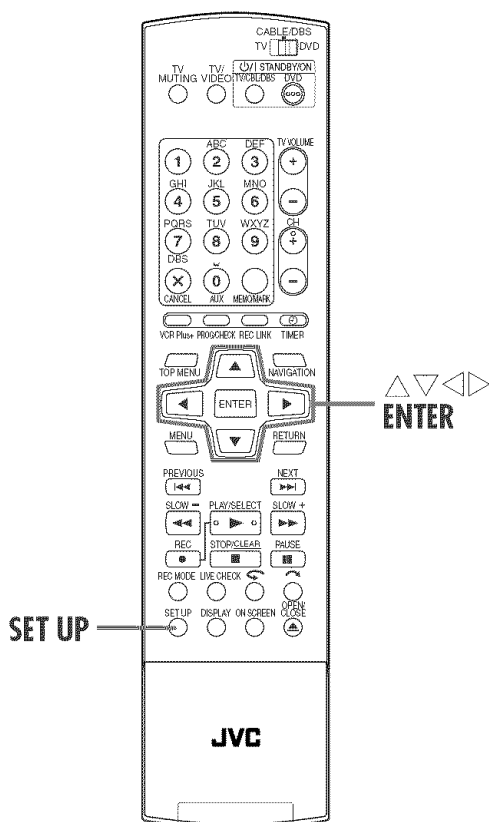

Format a DVD-RAM disc

1 Access the Main Menu screen.

Press **SET UP**.

2 Access the "UTILITY" screen.

- 1 Press $\Delta \nabla \triangleleft \triangleright$ to select "DVD SET UP", then press **ENTER**.
- 2 Press $\triangleleft \triangleright$ to select "UTILITY", then press **ENTER**.

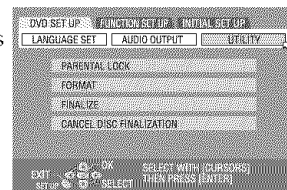

3 Format the disc.

- 1 Press $\Delta \nabla$ to select "FORMAT", then press **ENTER**. Press $\triangleleft \triangleright$ to select "YES", then press **ENTER** when "DISC WILL BE FORMATTED" appears on the TV screen.
- 2 Press $\triangleleft \triangleright$ to select "OK", then press **ENTER** when "DISC FORMATTING WAS SELECTED" appears on the TV screen.

Format a DVD-RW disc

Perform steps **1** to **2** of "Format a DVD-RAM disc" on the above before continuing.

1 Format the disc.

- 1 Press $\Delta \nabla$ to select "FORMAT", then press **ENTER**. Press $\triangleleft \triangleright$ to choose "VR MODE" or "VIDEO MODE", then press **ENTER** when "DISC WILL BE FORMATTED" appears on the TV screen.
 - "VR MODE": To be chosen when you want to record, erase, or edit data on the disc repeatedly.
 - "VIDEO MODE": To be chosen when you want to erase all the data on the disc once played back to record new data, or play the disc on other DVD players.
- 2 Press $\triangleleft \triangleright$ to select "YES", then press **ENTER** when "DISC WILL BE FORMATTED IN VR MODE/VIDEO MODE" appears on the TV screen.

NOTES:

- It is impossible to format Version 1.0 DVD-RW discs in Video mode.
- It is impossible to format DVD-R discs.
- All the programs on a disc will be deleted once the disc is formatted even if they are protected titles. (pg. 76, "Protect title")

Finalize a disc



Finalizing DVD-R/RW discs recorded on this unit makes it possible for the discs to be played back on other DVD players. DVD-RW discs are finalized in the mode that the discs were formatted, enabling playback on compatible DVD players. Titles input in the Library Database DVD Navi are registered as titles in the DVD menu. (☞ pg. 36, 76)

- Turn on the unit.
- Turn on the TV and select the AV mode.
- Slide the **TV/CABLE/DBS/DVD** switch to **DVD**.
- Load a DVD-R/RW disc to finalize.

Before finalizing

- It is possible to record on a blank space.
- It is possible to enter a program title. (☞ pg. 76, "Modify Program Name")
- It is possible to delete programs. (☞ pg. 77, "Delete program")
- It is impossible to overwrite recorded areas of DVD-R discs.
- Available recording capacity does not increase even if a recorded program is deleted from a DVD-R disc.
- It is impossible to record or edit DVD-R/RW discs recorded on other devices even if they have not been finalized.

After finalizing (For DVD-R/RW (Video mode) discs)

- Video and audio that have been recorded by then are recorded in conformity to the DVD Video standard, enabling you to play back the discs as DVD VIDEO discs. (☞ pg. 8, "Discs for Playback Only")
- Although DVD-R/RW discs finalized on this unit become playable on DVD players compatible with DVD-R/RW discs, some discs still may not play, for which JVC cannot take responsibility.
- Marked points marked before finalizing will be deleted, and programs will be divided automatically into "chapters" approximately every 5 minutes. (☞ pg. 38, "Marking positions to play again later")
- Depending on the DVD players and DVD-R/RW discs used, and on the conditions of recording, it may not be possible to play back the discs. In this case, play back the discs on this unit.
- Additional recordings become impossible.

Finalize a DVD-R/RW disc

Perform steps **1** to **2** of "Format a DVD-RAM disc" (☞ pg. 101) before continuing.

1 Finalize the disc.

- 1** Press \triangle/∇ to select "FINALIZE", then press **ENTER**. Press \triangle/∇ to select "YES", then press **ENTER** when "DISC WILL BE FINALIZED" appears on the TV screen.
- 2** Press \triangle/∇ to select "OK", then press **ENTER** when "FINALIZING WILL MAKE DISC READ-ONLY" appears on the TV screen.

2 Return to the normal screen.

Press **SET UP**.

- Menu screen is cleared.
- Once a DVD-R/RW (Video mode) disc has been finalized, the displays for original and play list do not appear. Only display for library appears.
- Once a DVD-RW (VR mode) disc has been finalized, it can be played on DVD players compatible with VR mode.

Cancel the finalization of a DVD-RW disc

Load a DVD-RW disc to cancel the disc finalization, and perform steps **1** to **2** of "Format a DVD-RAM disc" (☞ pg. 101) before continuing.

1 Cancel the disc finalization.

- 1** Press \triangle/∇ to select "CANCEL DISC FINALIZATION", then press **ENTER**.
- 2** Press \triangle/∇ to select "OK", then press **ENTER** when "CANCEL DISC FINALIZATION" appears on the TV screen.

2 Return to the normal screen.

Press **SET UP**.

- When the disc finalization is cancelled, the mode in which the disc was formatted is restored, making the disc recordable. (☞ pg. 9, 101)

Scan Mode Set

You can select the scan mode from two modes: Interlaced scan mode which is used in the conventional TV system, and Progressive scan mode which enables reproduction of higher-quality images. For details, refer to "GLOSSARY" (☞ pg. 108).

- Turn on the unit.
- Turn on the TV and select the AV mode.
- Slide the **TV/CABLE/DBS/DVD** switch to **DVD**.

ATTENTION:

Your TV needs to be compatible with Progressive.

1 Set the scan mode.

Press **PROGRESSIVE SCAN** for 3 or more seconds.

- Video output indicator (P) lights on the front display panel if Progressive scan mode has been established. (☞ pg. 15)
- Each press of **PROGRESSIVE SCAN** for 3 or more seconds switches the scan mode.

NOTES:

- Interlaced scan mode is the setting at your purchase.
- Interlaced scan mode might be suitable depending on video material.
- Scan mode cannot be set while menu screen is displayed.

Tray Lock

You can lock the disc tray to prohibit the unwanted disc ejection by children.

- Turn off the unit.

1 Lock the disc tray.

While the unit is turned off, press and hold ■, then press ▲ on the unit. "LOCK" appears on the front display panel.

- If you try to eject the discs, "LOCK" appears and indicates that tray is locked.

To unlock tray

While the unit is turned off, press and hold ■, then press ▲ on the unit. "UNLOCK" appears on the display panel.

Before requesting service for a problem, use this chart and see if you can solve the trouble yourself. Small problems are often easily solved, and this can save you the trouble of sending your unit off for repair.

GENERAL

SYMPTOM	POSSIBLE CAUSE	CORRECTIVE ACTION
1. No power is supplied to the unit.	<ul style="list-style-type: none"> The AC power plug is disconnected from the mains. 	Connect the AC power plug to the mains securely. (☞ pg. 18)
2. The channel cannot be changed.	<ul style="list-style-type: none"> Recording or Live Memory recording is in progress. 	Press II to pause recording, change the channel, then press ▶ to resume recording.
3. The Remote does not operate the unit.	<ul style="list-style-type: none"> The setting of the remote control code is inappropriate. The batteries are discharged. 	Set the same remote control code (1, 2, 3, or 4) on both the unit and the Remote. (☞ pg. 91) Replace the dead batteries with new ones.
4. Dubbing from the external equipment is not possible.	<ul style="list-style-type: none"> The setting of the input channel position is inappropriate. 	Select the input channel position ("F-1", "L-1", or "L-2") that corresponds to the input terminal connected to the external equipment. (☞ pg. 89)
5. The on-screen display superimposed on the program played back/received on this unit is recorded when you dub the program to an external recording equipment.	—	Set "SUPERIMPOSE" to "OFF". (☞ pg. 99)
6. The Remote does not work properly.	<ul style="list-style-type: none"> The batteries are discharged. 	Remove the batteries, wait for 5 minutes or more, then load the batteries again. Replace the dead batteries with new ones.
7. The unit does not operate.	<ul style="list-style-type: none"> There are cases when the operation is prohibited on the disc. Lightning or static electricity may cause malfunction of the unit. 	— Press ⏻ on the unit or DVD⏻ on the Remote to turn the power off, then press the button again to turn the power on.

PLAYBACK

SYMPTOM	POSSIBLE CAUSE	CORRECTIVE ACTION
1. Images do not appear on the TV screen.	<ul style="list-style-type: none"> The TV is not set to the AV mode. When interlace scanned program is played back, progressive scan mode is selected. 	Set the TV to the AV mode. Press and hold PROGRESSIVE SCAN until P disappears from the front display panel.
2. Playback does not start or stop immediately after playback is started by pressing ▶ . On the front display panel, "NO DISC" appears.	<ul style="list-style-type: none"> The disc is loaded upside down. A disc not being compatible with the unit is loaded. A dirty disc is loaded. Defective disc is loaded. 	Place the disc on the disc tray with the playback surface facing downward. (☞ pg. 11) Load a playable disc on the unit. (☞ pg. 7, 8) Clean the disc. (☞ pg. 11) Replace the warped or scratched disc with a normal one.
3. Images are blurred or distorted when you start High-Speed Search.	—	Images are blurred or distorted at the point where the playback speed changes and this is not a malfunction of the unit.
4. Playback does not start.	—	Playback does not start for approximately 30 seconds after recording is stopped and this is not a malfunction of the unit.
5. Playback does not start when you select a title or a chapter.	<ul style="list-style-type: none"> The Parental Lock is engaged and the disc is rated higher than the set level. 	Release the Parental Lock temporarily or change the set level. (☞ pg. 53)

RECORDING

SYMPTOM	POSSIBLE CAUSE	CORRECTIVE ACTION
1. The desired program cannot be recorded.	<ul style="list-style-type: none"> The channel position does not correspond to that in the receiving area. 	Set the correct channel position for the receiving broadcast. (☞ pg. 26)
2. Recording and editing cannot be made.	<ul style="list-style-type: none"> No disc or a disc not being compatible with the unit is loaded. The disc loaded is not formatted. A finalized DVD-R disc is loaded. The disc is full or does not have enough space for the program to be recorded. The protect tab on the DVD-RAM cartridge is set to the protect position. 	<p>Load a recordable disc on the unit. (☞ pg. 7)</p> <p>Format the disc. (☞ pg. 101)</p> <p>Recording and editing cannot be made on finalized discs. (☞ pg. 102) Load a recordable disc on the unit.</p> <p>Clear unnecessary programs on the disc or load a blank disc. (☞ pg. 77)</p> <p>Release the protect tab. (☞ pg. 11)</p>
3. Timer programing cannot be made.	<ul style="list-style-type: none"> Date and time is not correct. 	Set date and time correctly. (☞ pg. 24)
4. Timer programing recording does not start.	<ul style="list-style-type: none"> Power failure occurred before the timer programed recording starts. 	Check the timer programing. (☞ pg. 69)
5. VCR Plus+ Timer Programing cannot be made.	<ul style="list-style-type: none"> Date and time set on the unit is not correct. The channel position does not correspond to that in the receiving area. 	<p>Set date and time correctly. (☞ pg. 24)</p> <p>Set the correct channel position for the receiving broadcast. (☞ pg. 26)</p>
6. Satellite Auto Recording recording does not start.	<ul style="list-style-type: none"> The DBS receiver is not connected properly to this unit. 	Connect the DBS receiver to the AUDIO/VIDEO INPUT (L-1) connector properly. (☞ pg. 32)
7. On the front display panel, “- - -” appears.	<ul style="list-style-type: none"> Power failure occurred. 	Set date and time correctly. (☞ pg. 24)
8. “PROGRAM FULL” appears on the TV screen during timer programing.	<ul style="list-style-type: none"> Eight programs have already been timer programed. 	Clear unnecessary programs on the unit, then try timer programing again. (☞ pg. 69)
9. The disc space does not increase when recorded programs are cleared.	<ul style="list-style-type: none"> The PC's data recorded on a DVD-RAM drive cannot be cleared on this unit. 	Format the disc. (When the disc is soiled, wipe the disc with a soft dry cloth before formatting.) (☞ pg. 11, 101)

INITIALIZING

SYMPTOM	POSSIBLE CAUSE	CORRECTIVE ACTION
1. Malfunction occurs on the unit.	—	Press $\phi/1$ to turn off the unit, press and hold $\phi/1$, then press \blacksquare for two seconds or more.
2. The Disc Tray doesn't open.	—	<p>Take out the disc in following ways.</p> <ul style="list-style-type: none"> Connect and the disconnect the power cord from the main outlet. Press and hold the open/close button (\blacktriangle) on the unit until the disc tray opens. (it will take about 30sec.) Close the disc tray by pressing the open/close button after taking out the disc. (the main power shuts down.)

ATTENTION:

This unit contains microcomputers. External electronic noise or interference could cause malfunctioning. In such cases, switch the unit off and unplug the mains power cord. Then plug it in again and turn the unit on. Take out the disc. After checking the disc, operate the unit as usual.

ON-SCREEN MESSAGES

MESSAGE	DESCRIPTION
MEMORY IS FULL NOTHING MORE CAN BE REGISTERED IN THE LIBRARY IF YOU DELETE UNNECESSARY TITLE INFORMATION, YOU CAN THEN REGISTER ADDITIONAL INFORMATION	The memory is full for registration for the Navigation system. The recording cannot be started even though the capacity for the recording is enough. (☞ pg. 77)
AVAILABLE MEMORY IS LOW SOON YOU WILL NO LONGER BE ABLE TO REGISTER INFORMATION IN THE LIBRARY IF YOU DELETE UNNECESSARY TITLE INFORMATION, YOU CAN THEN REGISTER ADDITIONAL INFORMATION	The remaining capacity of the memory is not enough for registration for the Navigation system. The recording cannot be started even though the capacity for the recording is enough. (☞ pg. 77)
DISC NOT REGISTERED IN THE LIBRARY REGISTER DISC?	A disc that is not registered in the library has been inserted. Register the disc as necessary. (☞ pg. 83)
INSERT DISC #XXXX	Appears when a title that has been selected in the library is not contained in the loaded disc. (☞ pg. 82)
CAN NOT RECORD OR MAKE PLAY LIST DELETE UNWANTED TITLES	<ul style="list-style-type: none"> ● Recording and/or editing cannot be performed with a loaded DVD-RAM disc. ● The number of titles exceeds 99. ● The number of play lists exceeds 999.
SET CLOCK BEFORE TIMER PROGRAMING	To set the timer program, the clock must be set in advance. (☞ pg. 24)
PROGRAM FULL DELETE UNWANTED TIMER PROGRAM	You can program this unit to timer-record as many as 8 programs. To program more, you need to cancel a timer program already set. (☞ pg. 69)
CAN NOT SET DISC TIMER PROGRAMING WITH THIS DISC PREPARE A FORMATTED DISC AS DESCRIBED BELOW DVD-RAM DVD-RW (VR MODE)	On-Disc Timer Programing has been attempted when a disc that is not compatible with the function is loaded. (☞ pg. 66)
NO DISC INSERTED	On-Disc Timer Programing has been attempted when a disc is not loaded, or loaded upside down. (☞ pg. 11, 66)
DISC NOT RECORDABLE INSERT RECORDABLE DISC	When a playback-only disc or a finalized disc is loaded, ● has been pressed. (☞ pg. 8, 102)
PLUSCODE NO. ERROR CONFIRM PLUSCODE NO. THEN RETRY	An invalid PlusCode number has been input. (☞ pg. 60)
GUIDE PROGRAM IS NOT SET SELECT CHANNEL YOU WANT TO RECORD	To set the timer program using the VCR Plus+ system, the Guide Channel number must be set in advance. (☞ pg. 62)
CAN NOT SET VCR PLUS+ TIMER PROGRAMING DURING TIMER RECORDING OR INSTANT TIMER RECORDING CANCEL TIMER RECORDING OR INSTANT TIMER RECORDING, THEN ENTER THE PLUSCODE AGAIN	Appears when you tried to input a PlusCode number during timer recording or instant timer recording.
REGION CODE ERROR CHECK DISC	A disc loaded cannot be played back on this unit since the region number of the disc does not match that of the unit. (☞ pg. 8)
UNREADABLE DISC CHECK DISC	When an incompatible disc is loaded, ► has been pressed. (☞ pg. 8)
COULD NOT FORMAT THE DISC CHECK THE DISC	Formatting is not complete since the disc may be dirty or damaged. Take out the disc, clean it and retry. (☞ pg. 11, 101)
COULD NOT FINALIZE THE DISC CHECK THE DISC	Finalizing is not complete since the disc may be dirty or damaged. Take out the disc, clean it and retry. (☞ pg. 11, 102)
COULD NOT CANCEL DISC FINALIZATION CHECK THE DISC	Cancelling disc finalization is not complete since the disc may be dirty or damaged. Take out the disc, clean it and retry. (☞ pg. 11, 102)

MESSAGE	DESCRIPTION
PRESS [STOP] AGAIN TO STOP RECORDING	During Live Memory playback, ■ has been pressed. (pg. 44)
TIMER RECORDING COMPLETED	Timer recording has finished during Live Memory playback.
PLAYBACK WILL STOP THEN TIMER RECORDING WILL START	Timer recording finished during Live Memory playback, then the next timer recording is about to begin while playback continues.
COPY PROHIBITED CAN NOT RECORD	<ul style="list-style-type: none"> ● An attempt has been made to record copy-protected contents. ● An attempt has been made to record copy-once contents on a disc that is not CPRM compatible, such as DVD-R.
COPY PROHIBITED CAN NOT PLAY	The unit has detected invalid contents at the start or in the middle of playback.
THE i.LINK DEVICE THAT YOU HAVE CONNECTED IS NOT RECOGNIZED MAKE SURE THAT THE DEVICE IS CONNECTED PROPERLY AND POWERED ON	An attempt has been made to start DV dubbing when a digital video camera is not properly connected to the unit. Check the connection. (pg. 86)

■ Aspect ratio

The ratio of vertical and horizontal sizes of a displayed image. The horizontal vs. vertical ratio of conventional TVs is 4:3, and that of wide-screens is 16:9.

■ Chapter

Refers to individual chapters included in a title.

■ Composite video signal

Refers to video signal comprised of three kinds of signals combined: an image signal made up of luminance and chrominance signals using the frequency multiplication technique; burst signal providing the basis for colour reproduction; and synchronization signal.

■ Component video signal

A video signal system where parts of information necessary for reproducing image signal comprised of the three primary colours of light are transmitted via separate signal lines. Types of signal, such as R/G/B, Y/P_b/P_r, etc., are available.

■ Disc menu

A screen display prepared for allowing selection of images, sounds, subtitles, multiangles, etc. recorded on a DVD disc.

■ Dolby Digital (AC-3)

A six-channel system consisting of left, centre, right, left rear, right rear and LFE (Low-Frequency Effect channel, for use with a sub-woofer) channels. All processing is done in the digital domain.

Not all Dolby Digital discs contain six (5.1) channels of information.

■ Down-mix

Internal stereo mix of multichannel surround audio by a DVD player. The down-mix signals are output from stereo output connectors.

■ DTS

A Digital Surround audio encoding format configured with six (5.1) channels, similar to Dolby Digital. It requires a decoder, either in the player or in an external receiver. DTS stands for Digital Theater Systems.

Not all DTS discs contain six (5.1) channels of information.

■ Interlaced scan

In the conventional video system, a picture is shown on the display monitor in two halves. The Interlaced scan system places lines of the second half of the picture in-between lines of the first half of the picture.

■ JPEG

A still-picture data compression system proposed by the Joint Photographic Expert Group, which features small decrease in image quality in spite of its high compression ratio.

■ Letter box

A method of displaying wide images like movies in the centre of a 4:3 TV screen with no part of the image deleted, by placing black bands on the top and bottom of the screen. This name has resulted from the screen form looking literally like a letter box.

■ Linear PCM (PCM: Pulse Code Modulation)

A system for converting analog sound signal to digital signal for later processing, with no data compression used in conversion.

■ MP3

A file format with a sound data compression system. "MP3" is the abbreviation of Motion Picture Experts Group 1 (or MPEG-1) Audio Layer 3. By using MP3 format, one CD-R/RW can contain about 10 times as much data volume as a regular CD can.

■ MPEG

A family of Standards for compressing audio-visual information. "MPEG" standards include MPEG-1, MPEG-2 and MPEG-4. Video CD/SVCD and MP3 are based on MPEG-1, while DVD is based on MPEG-2. MPEG stands for Moving Picture coding Experts Group.

■ Multiangle

By recording multiple scenes progressing at the same time in a single title, the user can select view angles. This feature is called the multiangle function.

■ Multichannel

DVD is specified to have each sound track constitute one sound field. Multichannel refers to a structure of sound tracks having three or more channels.

■ Multilanguage

When a title is created to cope with multiple languages, it is generally called a multilanguage title.

■ NTSC (National television system committee)

A black and white and colour television system format used in the U.S.A., Canada, Mexico and Japan.

■ PAL (Phase Alternation by Line)

A colour television system format used extensively in Western Europe.

■ Parental Lock

A feature of this system to automatically determine whether or not to reproduce particular DVD software by comparing its parental lock level (a measure of undesirability of scenes, etc. from educational viewpoint) set for the software beforehand with that set on this system by the user; if the software's level is less restrictive than the user-set level, it will be reproduced.

■ Playback control (PBC)

Refers to the signal recorded on Video CDs/SVCD for controlling reproduction. By using menu screens recorded on a Video CD/SVCD that supports PBC, you can enjoy interactive-type software as well as software having a search function.

■ Progressive scan

Progressive scan displays all the horizontal lines of a picture at one time, as a single frame. This system can convert the interlaced video from DVD into progressive format for connection to a progressive display. It dramatically increases the vertical resolution.

■ Region Code

A system for allowing discs to be played back only in the regions designated beforehand. All the countries in the world are grouped into six regions, each region being identified by a specified Region Code (or region number). If the Region Code given to a disc includes a numeral which matches one in the Region Code of a player, the player can play back the disc.

■ Sampling frequency

Frequency of sampling data when analog data is converted to digital data. Sampling frequency numerically represents how many times the original analog signal is sampled per second.

■ Surround

A system for creating three-dimensional sound fields full of realism by arranging multiple speakers around the listener.

■ Transfer rate

The rate of transferring digital data. Usually the measure is in baud per second. The DVD system applies a variable transfer rate system for high efficiency.

GENERAL

Power requirement : AC 120 V~, 60 Hz
 Power consumption
 Power on : 34 W
 Power off : 16.2 W
 Temperature
 Operating : 5°C to 40°C (41°F to 104°F)
 Storage : -20°C to 60°C (-4°F to 140°F)
 Operating position : Horizontal only
 Dimensions (WxHxD)
 : 435 mm x 70 mm x 346 mm
 Weight : 4.5 kg

VIDEO/AUDIO

Recordable disc : DVD-RAM 12 cm (4.7 GB/9.4 GB)
 DVD-RAM 8 cm (1.4 GB/2.8 GB)
 DVD-R (12 cm: 4.7 GB,
 8 cm: 1.4 GB for General Ver. 2.0)
 DVD-RW (4.7 GB for Ver. 1.0/1.1)
 Recording format
 DVD-RAM : DVD Video Recording format
 DVD-R : DVD-Video format
 DVD-RW : DVD-Video format, DVD Video
 Recording format
 Recording time
 Maximum 8 hours (with 4.7 GB disc)
 (XP) : Approx. 1 hour
 (SP) : Approx. 2 hours
 (LP) : Approx. 4 hours
 (EP) : Approx. 6 hours
 (FR) : Approx. 1 hour – 8 hours
 Playable disc : DVD-RAM 12 cm (4.7 GB/9.4 GB)
 DVD-RAM 8 cm (1.4 GB/2.8 GB)
 DVD-R (12 cm: 4.7 GB,
 8 cm: 1.4 GB for General Ver. 2.0)
 DVD VIDEO, DVD-RW (4.7 GB)
 Music CD (CD-DA)
 Video CD
 Super Video CD (SVCD)
 CD-R/RW (CD-DA, Video CD/
 SVCD formatted discs)
 Audio recording system
 : Dolby Digital (2 ch)
 Linear PCM (XP mode only)
 Video recording compression system
 : MPEG2 (CBR/VBR)

Input/Output

S-video input
 Y : 0.8 – 1.2 Vp-p, 75 ohms
 C : 0.2 – 0.4 Vp-p, 75 ohms
 S-video output
 Y : 1.0 Vp-p, 75 ohms
 C : 0.3 Vp-p, 75 ohms
 Video input : 0.5 – 2.0 Vp-p, 75 ohms (pin jack)
 Video output : 1.0 Vp-p, 75 ohms (pin jack)
 Audio input : -8 dB, 50 kilohms (pin jack)
 Corresponding to mono (left)
 Audio output : -8 dB, 1 kilohms (pin jack)
 i.Link : 4-pin for DV input
 Component video output
 Y : 1.0 Vp-p, 75 ohms
 PB/PR : 0.7 Vp-p, 75 ohms
 Corresponding to copy protection
 Digital audio output
 Optical : -18 dBm, 660 nm
 Coaxial : 0.7 Vp-p, 75 ohms
 Corresponding to Dolby Digital and
 DTS Digital Surround
 Bit stream
 Selectable in digital audio output
 setting menu

TUNER

Tuning system : Frequency synthesized tuner
 Channel coverage
 VHF : Channels 2 – 13
 UHF : Channels 14 – 69
 CATV : 113 Channels

TIMER

Clock reference : Quartz
 Program capacity : 1-year programmable timer/
 8 programs
 Memory backup time : Approx. 60 min.

ACCESSORIES

Provided accessories
 : RF cable,
 Audio/video cable,
 Controller,
 Infrared remote control unit,
 "AA" battery x 2

Specifications shown are for SP mode unless otherwise specified.
 E.& O.E. Design and specifications subject to change without notice.

A		R	
A-B Repeat Playback	49	Random Playback	52
Adjusting the picture quality	51	Recordable/playable discs	7
Angle Selection	39	Recording Medium and Format	9
Audio Channel Selection	40	Recording Resume Function	57
Audio Language/Sound Selection	39	RECORDING SET	98
AUDIO OUTPUT	97	Recording Speed	58
Auto Channel Set	26	Region Number	8
C		Register disc	83
Check, cancel and change programs	69	Repeat Playback	48
Clock Set	24	Resume Function	37
Controller	32	S	
D		Scan Mode Set	103
DBS receiver	32	Select the switching interval of the slide show	52
Delete program	77	Semiauto Clock Set	24
Disc menu	36	Setting the progressive mode	51
Discs for Playback Only	8	Simulated Surround Effect	50
DISPLAY SET	99	Skip Search	37
DVD menu	36	Slow Motion	37
F		Still Picture/Frame-By-Frame Playback	37
File Structure of Discs	9	Subtitle Selection	39
Free Rate Function	59	T	
G		Time Search	50
Guide Channel Number	63	Top menu	36
H		Tuner Set	26
High-Speed Search	37	U	
I		Unplayable Discs	8
Instant Timer Recording (ITR)	58		
L			
Letter Box	28		
Library Database DVD Navi	72		
Live Memory	41		
M			
Manual Channel Set	27		
Manual Clock Set	25		
Marking positions to play again later	38		
Menu/Audio/Subtitle Language Set	22		
O			
On-Disc Timer Programming	66		
One Touch Replay	45		
On-screen Language Set	22		
P			
Pan&Scan	28		
Parental Lock	53		
Play List	78		
Play Set Up Menu	46		
Playback Control (PBC)	40		
Plug&Play Set	21		
Program Playback	52		



LIMITED WARRANTY USA ONLY ONLY FOR PRODUCT PURCHASED IN U.S.A. CONSUMER VIDEO 1-90

JVC COMPANY OF AMERICA warrants this product and all parts thereof, except as set forth below ONLY TO THE ORIGINAL PURCHASER AT RETAIL to be FREE FROM DEFECTIVE MATERIALS AND WORKMANSHIP from the date of original retail purchase for the period as shown below. ("The Warranty Period")

THIS LIMITED WARRANTY IS VALID ONLY IN THE FIFTY (50) UNITED STATES, THE DISTRICT OF COLUMBIA AND IN COMMONWEALTH OF PUERTO RICO.

WHAT WE WILL DO:

If this product is found to be defective, JVC will repair or replace defective parts at no charge to the original owner. Such repair and replacement services shall be rendered by JVC during normal business hours at JVC authorized service centers. Parts used for replacement are warranted only for the remainder of the Warranty Period. All products and parts thereof may be brought to a JVC authorized service center on a carry-in basis except for Television sets having a screen size 25 inches and above which are covered on an in-home basis.

WHAT YOU MUST DO FOR WARRANTY SERVICE:

Return your product to a JVC authorized service center with a copy of your bill of sale. For your nearest JVC authorized service center, please call toll free: (800) 252-5722.

If service is not available locally, box the product carefully, preferably in the original carton, and ship, insured, with a copy of your bill of sale plus a letter of explanation of the problem to the nearest JVC Factory Service Center, the name and location of which will be given to you by the toll-free number.

If you have any questions concerning your JVC Product, please contact our Customer Relations Department.

WHAT IS NOT COVERED:

- This limited warranty provided by JVC does not cover: 1. Products which have been subject to abuse, accident, alteration, modification, tampering, negligence, misuse, faulty installation, lack of reasonable care, or if repaired or serviced by anyone other than a service facility authorized by JVC to render such service, or if affixed to any attachment not provided with the products, or if the model number or serial number has been altered, tampered with, defaced or removed; 2. Initial installation and installation and removal for repair; 3. Operational adjustments covered in the Owner's Manual, normal maintenance, video and audio head cleaning; 4. Damage that occurs in shipment, due to act of God, and cosmetic damage; 5. Signal reception problems and failures due to line power surge; 6. Video Pick-up Tubes/CCD Image Sensor, Cartridge, Stylus (Needle) are covered for 90 days from the date of purchase; 7. Accessories; 8. Batteries (except that Rechargeable Batteries are covered for 90 days from the date of purchase);

There are no express warranties except as listed above.

THE DURATION OF ANY IMPLIED WARRANTIES, INCLUDING THE IMPLIED WARRANTY OF MERCHANTABILITY, IS LIMITED TO THE DURATION OF THE EXPRESS WARRANTY HEREIN.

JVC SHALL NOT BE LIABLE FOR ANY LOSS OF USE OF THE PRODUCT, INCONVENIENCE, LOSS OR ANY OTHER DAMAGES, WHETHER DIRECT, INCIDENTAL OR CONSEQUENTIAL (INCLUDING, WITHOUT LIMITATION, DAMAGE TO TAPES, RECORDS OR DISCS) RESULTING FROM THE USE OF THIS PRODUCT, OR ARISING OUT OF ANY BREACH OF THIS WARRANTY. ALL EXPRESS AND IMPLIED WARRANTIES, INCLUDING THE WARRANTIES OF MERCHANTABILITY AND FITNESS FOR PARTICULAR PURPOSE, ARE LIMITED TO THE WARRANTY PERIOD SET FORTH ABOVE.

Some states do not allow the exclusion of incidental or consequential damages or limitations on how long an implied warranty lasts, so these limitations or exclusions may not apply to you. This warranty gives you specific legal rights and you may also have other rights which vary from state to state.

JVC COMPANY OF AMERICA DIVISION OF JVC AMERICAS CORP.

1700 Valley Road Wayne, NJ 07470

REFURBISHED PRODUCTS CARRY A SEPARATE WARRANTY, THIS WARRANTY DOES NOT APPLY. FOR DETAILS OF REFURBISHED PRODUCT WARRANTY, PLEASE REFER TO THE REFURBISHED PRODUCT WARRANTY INFORMATION PACKAGED WITH EACH REFURBISHED PRODUCT.

For customer use:

Enter below the Model No. which is located either on the rear, bottom or side of the cabinet. Retain this information for future reference.

Model No. :

Serial No. :

Purchase date :

Name of dealer :

FOR SERVICING (Only in U.S.A.)

Authorized Service Centers _____

QUALITY **JVC**[®] SERVICE
HOW TO LOCATE YOUR JVC SERVICE CENTER
TOLL FREE: 1 (800) 252-5722
<http://www.jvc.com>

Dear Customer,

In order to receive the most satisfaction from your purchase, please read the instruction booklet before operating the unit. In the event that repairs are necessary, please call 1 (800) 252-5722 for your nearest authorized service location or visit our website at www.JVC.com

Remember to retain your Bill of Sale for Warranty Service.

_____ **Do not attempt to service the product yourself** _____

Caution

To prevent electrical shock, do not open the cabinet. There are no user serviceable parts inside. Please refer to qualified service personnel for repairs.

Accessories

To purchase accessories for your JVC product, please call toll free: 1 (800) 252-5722 or visit us on the web at www.JVC.com

JVC
VICTOR COMPANY OF JAPAN, LIMITED