

JVC



MICRO COMPONENT SYSTEM

UX-G49—Consists of CA-UXG49 and SP-UXG49

UX-G48—Consists of CA-UXG48 and SP-UXG48

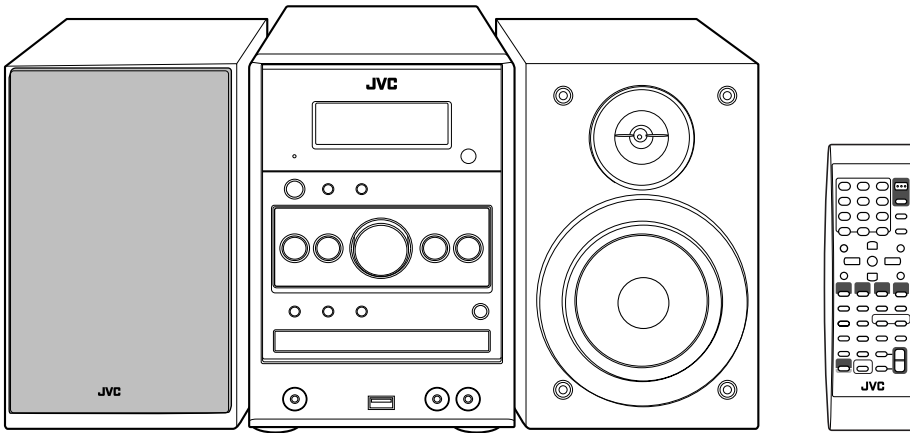

Radio Data System

MP3/WMA/WAV

Digital Direct Progressive Scan

INSTRUCTIONS

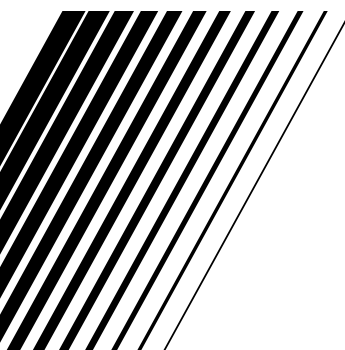

Warnings, Cautions and Others

IMPORTANT for the U.K.

DO NOT cut off the mains plug from this equipment. If the plug fitted is not suitable for the power points in your home or the cable is too short to reach a power point, then obtain an appropriate safety approved extension lead or consult your dealer.

BE SURE to replace the fuse only with an identical approved type, as originally fitted.

If nonetheless the mains plug is cut off ensure to remove the fuse and dispose of the plug immediately, to avoid a possible shock hazard by inadvertent connection to the mains supply.

If this product is not supplied fitted with a mains plug then follow the instructions given below:

IMPORTANT:

DO NOT make any connection to the terminal which is marked with the letter E or by the safety earth symbol or coloured green or green-and-yellow.

The wires in the mains lead on this product are coloured in accordance with the following code:

Blue: Neutral
Brown: Live

As these colours may not correspond with the coloured markings identifying the terminals in your plug proceed as follows:

The wire which is coloured blue must be connected to the terminal which is marked with the letter N or coloured black.

The wire which is coloured brown must be connected to the terminal which is marked with the letter L or coloured red.

IF IN DOUBT - CONSULT A COMPETENT ELECTRICIAN.

CAUTION— ϕ /I (Standby/on) button!

Disconnect the mains plug to shut the power off completely (the STANDBY lamp goes off). When installing the apparatus, ensure that the plug is easily accessible. The ϕ /I (Standby/on) button in any position does not disconnect the mains line.

- When the System is on standby, the STANDBY lamp lights red.
- When the System is turned on, the STANDBY lamp goes off. The power can be remote controlled.

CAUTION

To reduce the risk of electrical shocks, fire, etc.:

1. Do not remove screws, covers or cabinet.
2. Do not expose this appliance to rain or moisture.

IMPORTANT FOR LASER PRODUCTS

1. CLASS 1 LASER PRODUCT
2. **CAUTION:** Do not open the top cover or cabinet. There are no user serviceable parts inside the unit; leave all servicing to qualified service personnel.
3. **CAUTION:** Visible and/or invisible class 1M laser radiation when open. Do not view directly with optical instruments.
4. REPRODUCTION OF LABEL: CAUTION LABEL, PLACED INSIDE THE UNIT.

CAUTION VISIBLE AND/OR INVISIBLE CLASS 1M LASER RADIATION WHEN OPEN. DO NOT VIEW DIRECTLY WITH OPTICAL INSTRUMENTS. IEC00025-1:2009	ATTENTION RAYONNEMENT LASER VISIBLE ET/OU INVISIBLE DE CLASSE 1M. NE PAS REGARDER DIRECTEMENT AVEC DES INSTRUMENTS OPTIQUES. (ENG)	AVISO RADIACION LASER DE CLASE 1M VISIBLE Y/O INVISIBLE CUANDO ESTA ABIERTO. NO MIRAR DIRECTAMENTE CON INSTRUMENTAL OPTICO. (SPA)	VARNING SYNLIG OCH/ELLER OBSYNLIG LASERSTRÅLNING. KLASS 1M, NÄR DENNA DEL ÄR ÖPPNAD. BETRÄKTA EJ STRÅLEN MED OPTISKA INSTRUMENT. (SWE)	注意 この装置から発する レーザー光は有害な レーザー放射線が 発生する。 光学機器で直接 見ないでください。 (JPN)	CAUTION VISIBLE AND/OR INVISIBLE CLASS II LASER RADIATION WHEN OPEN. DO NOT STARE INTO BEAM. FOM 21 CTR (ENG) LV44903-003A
---	--	--	---	---	---

CAUTION

- Do not block the ventilation openings or holes. (If the ventilation openings or holes are blocked by a newspaper or cloth, etc., the heat may not be able to get out.)
- Do not place any naked flame sources, such as lighted candles, on the apparatus.
- When discarding batteries, environmental problems must be considered and local rules or laws governing the disposal of these batteries must be followed strictly.
- Do not expose this apparatus to rain, moisture, dripping or splashing and that no objects filled with liquids, such as vases, shall be placed on the apparatus.

CAUTION:

Excessive sound pressure from earphones or headphones can cause hearing loss.

Dear Customer,

This apparatus is in conformance with the valid European directives and standards regarding electromagnetic compatibility and electrical safety.

European representative of Victor Company of Japan, Limited is:

JVC Technology Centre Europe GmbH
Postfach 10 05 52
61145 Friedberg
Germany

Information for Users on Disposal of Old equipment

[European Union]



This symbol indicates that the electrical and electronic equipment should not be disposed as general household waste at its end-of-life. Instead, the product should be handed over to the applicable collection point for the recycling of electrical and electronic equipment for proper treatment, recovery and recycling in accordance with your national legislation.

By disposing of this product correctly, you will help to conserve natural resources and will help prevent potential negative effects on the environment and human health which could otherwise be caused by inappropriate waste handling of this product, please contact your local municipal office, your household waste disposal service or the shop where you purchased the product.

Penalties may be applicable for incorrect disposal of this waste, in accordance with national legislation.

Attention:

This symbol is only valid in the European Union.

(Business users)

If you wish to dispose of this product, please visit our web page www.jvc-europe.com to obtain information about the take-back of the product.

[Other Countries outside the European Union]

If you wish to dispose of this product, please do so in accordance with applicable national legislation or other rules in your country for the treatment of old electrical and electronic equipment.

Caution: Proper Ventilation

To avoid risk of electric shock and fire, and to prevent damage, locate the apparatus as follows:

1. Front: No obstructions and open spacing.
2. Sides/Top/ Back: No obstructions should be placed in the areas shown by the dimensions below.
3. Bottom: Place on the level surface. Maintain an adequate air path for ventilation by placing on a stand with a height of 10 cm or more.

Front view

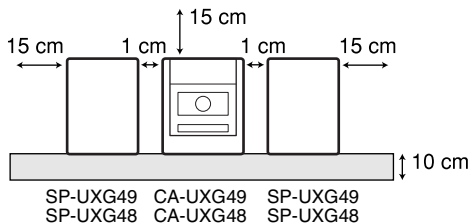

Side view

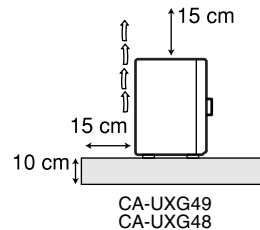

Introduction

Thank you for purchasing a JVC product. Please read all instructions carefully before operation, to ensure your complete understanding and to obtain the best possible performance from the System.

Precautions

Installation

- Install the System in a location with adequate ventilation to prevent internal heat build-up in the System.



DO NOT install the System in a location near heat sources, or in a place subject to direct sunlight, excessive dust or vibration.

- Install in a place which is level, dry and neither too hot nor too cold—between 5°C and 35°C.
- Leave sufficient distance between the System and the TV.
- Keep the speakers away from the TV to avoid interference with the TV.

Power sources

- When unplugging the System from the wall outlet, always pull on the plug, not the power cord.



DO NOT handle the power cord with wet hands.

Moisture condensation

Moisture may condense on the lenses inside the System in the following cases:

- After starting to heat the room
- In a damp room
- If the System is brought directly from a cold to a warm place.

Should this occur, the System may malfunction. In this case, leave the System turned on for a few hours until the moisture evaporates, unplug the power cord, then plug it in again.

Internal heat

- Make sure there is good ventilation around the System. Poor ventilation could overheat and damage the System.



DO NOT block the ventilation openings or holes. If they are blocked by a newspaper or cloth, etc., the heat may not be able to get out.

Others









- Should any metallic object or liquid fall into the System, unplug the power cord and consult your dealer before operating any further.



DO NOT disassemble the System since there are no user serviceable parts inside.

- If you are not going to operate the System for an extended period of time, unplug the power cord from the wall outlet. If anything goes wrong, unplug the power cord and consult your dealer.

Playable Disc/File Types

   
MP3/WMA/WAV
    
<ul style="list-style-type: none">• CD-R/-RW: Recorded in the Audio CD, Video CD, and SVCD formats. MP3, WMA, WAV, JPEG, MPEG-1, MPEG-2 and DivX files written in accordance with the “ISO 9660” format can also be played.
<ul style="list-style-type: none">• DVD-R/-RW, +R/+RW: Recorded in the DVD Video format. MP3, WMA, WAV, JPEG, MPEG-1, MPEG-2 and DivX files written in the UDF-Bridge format can also be played.
<ul style="list-style-type: none">• DVD-R/-RW: Recorded in the DVD Video Recording (VR) format.
<ul style="list-style-type: none">• DVD-ROM: Recorded in the MP3, WMA, WAV, JPEG, MPEG-1, MPEG-2 and DivX format.
<ul style="list-style-type: none">• USB mass storage class device: MP3, WMA, WAV, JPEG, MPEG-1, MPEG-2 and DivX files.

In addition to the above discs/files, this System can play back audio data recorded on CD-Extra.

- The following discs cannot be played back: DVD-RAM, CD-I (CD-I Ready), CD-ROM, Photo CD, CD-G (CD-Graphics) and DVD/CD Text. Playing back these discs will generate noise and damage the speakers.
- In this manual, “file” and “track” are used interchangeably for MP3/WMA/WAV/JPEG/MPEG-1/MPEG-2/DivX operations.
- It is possible to play back finalized +R/+RW (DVD Video format only) discs. “DVD” lights on the front display panel when a +R/+RW disc is loaded.
- “DVD Logo” is a trademark of DVD Format/Logo Licensing Corporation.

About color system

This System is compatible with PAL video format. You cannot play back NTSC discs properly.

Note on Region Code

DVD players and DVDs have their own Region Code numbers. This System can play back only DVDs with Region Code numbers including “2.”

EX.:



Caution for DualDisc playback

The Non-DVD side of a “DualDisc” does not comply with the “Compact Disc Digital Audio” standard. Therefore, the use of the Non-DVD side of a DualDisc in this product may not be recommended.

IMPORTANT: Before playing a disc/file, make sure of the following...







- Turn on the TV and select an appropriate input mode on the TV to view the pictures or on-screen displays.
- For disc/file playback, you can change the initial setting to your preference. See “Setup Menu Operations” on page 31.

If “” appears on the TV screen when you press a button, the disc/file cannot perform the operation you have tried to do.

- When playing a multi-channel encoded software, the System properly converts the multi-channel signals into 2 channels, and emits the downmixed sound from the speakers. To enjoy the powerful sound of these multi-channel encoded software, connect a proper decoder or an amplifier with a proper built-in decoder to the OPTICAL DIGITAL OUT terminal on the rear.

How to Read This Manual

- Button and control operations are explained in the table below.
- Some related tips and notes are explained later in the sections “Learning More about This System” and “Troubleshooting,” but not in the same section explaining the operations ( indicates that the content has some information).

	Indicates that you press the button briefly .
	Indicates that you press the button briefly and repeatedly until the option you want is selected.
	Indicates that you press one of the buttons.
	Indicates that you press and hold the button for a specified period.
	Indicates that you turn the control in the specified direction(s).
	Indicates that this operation is only possible using the remote control.
	Indicates that this operation is only possible using the main unit.

Contents

Connections	3
Display Indicators	6
Daily Operations—Playback	7
Listening to the Radio	8
Listening to the TV Sound	9
Playing Back a Disc/USB mass storage class device	9
Playing Back a Digital Audio Player	11
Daily Operations—Sound & Other Adjustments	12
Adjusting the Volume	12
Adjusting the Sound	12
Creating 3-Dimensional Sound Field—3D Phonic	13
Using Headphone Surround	13
Making Dialogues Clear—Clear Voice	13
Presetting Automatic DVD Sound Increase Level	13
Changing the Display Brightness	13
Changing the Scanning Mode	14
Changing the Picture Tone	14
Setting the Clock	15
Turning Off the Power Automatically	15
Advanced Radio Operations	16
Receiving FM Stations with Radio Data System	16
Searching for a Program by PTY Codes	16
Switching Temporarily to a Program of Your Choice Automatically	17
Unique Video Disc/File Operations	18
Selecting the Audio Track	18
Selecting the Subtitle Language	19
Selecting the View Angle	19
Special Effect Playback	20
Advanced Playback Operations	21
Programming the Playing Order—Program Play	21
Playing at Random—Random Play	22
Playing Repeatedly	22
Prohibiting Disc Ejection—Child Lock	23
On-Screen Operations	24
On-screen Bar Operations	24
Operations on the Control Screen	27
Daily Timer Operations	29
Setup Menu Operations	31
Additional Information	33
Learning More about This System	33
Maintenance	35
Troubleshooting	36
Language Code List	37
OPTICAL DIGITAL OUT Signals	38
Operating JVC’s TVs Using the Remote Control	38
Specifications	39
Parts Index	40

Connections INFO

Do not connect the power cord until all other connections have been made.

- Connect AV (SCART) directly to the video input of your TV. Connecting AV (SCART) to a TV via a VCR may interfere with your viewing when playing back copy-protected discs/files. Connecting AV (SCART) to an integrated TV/VCR system may also interfere with your viewing.

Supplied accessories

Check to be sure that you have all the following items.

- FM antenna (x1)
- AM loop antenna (x1)
- Remote control (x1)
- Batteries (x2)

If any items are missing, consult your dealer immediately.

Rear panel

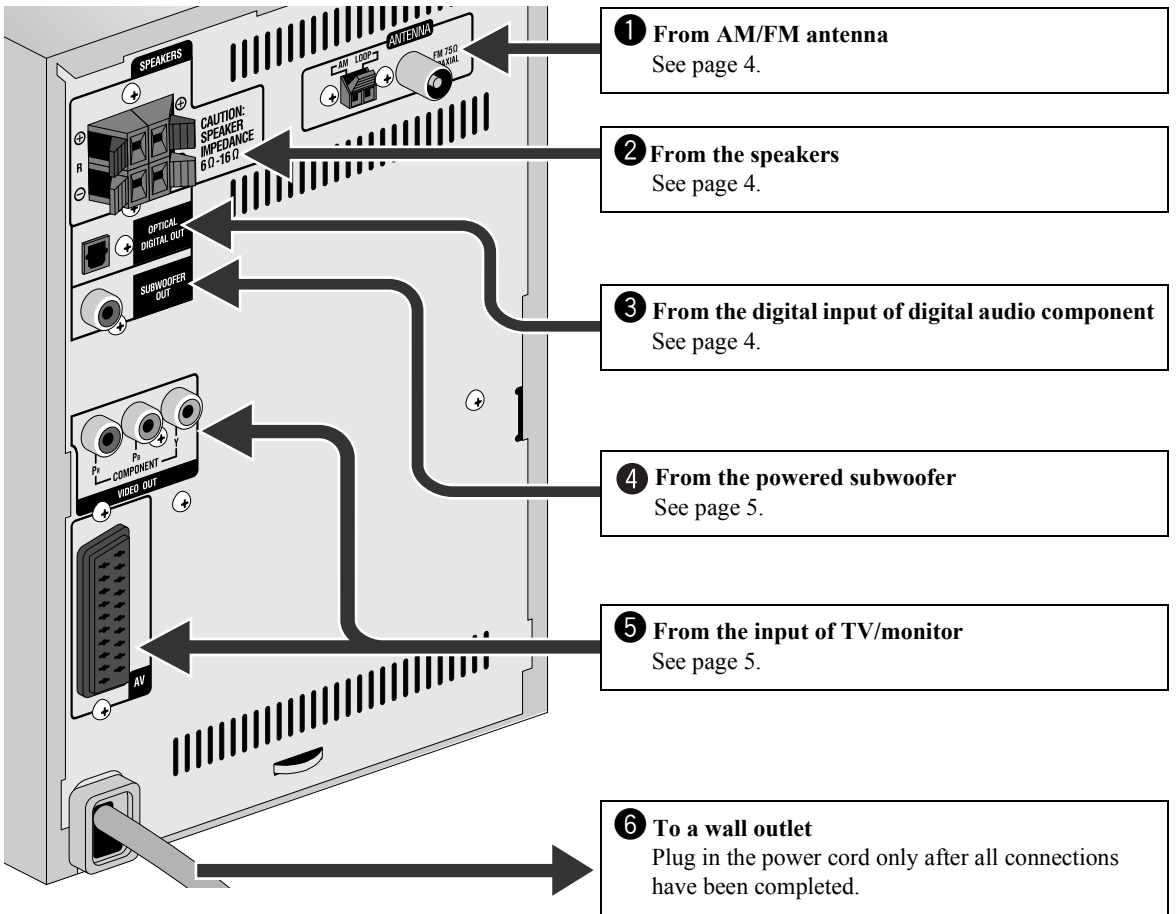

Front panel

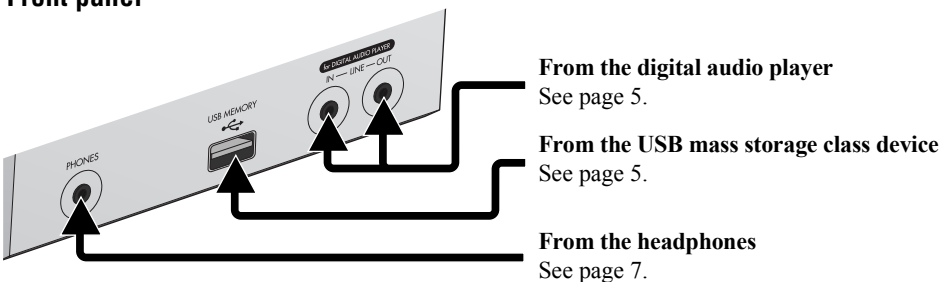

1 AM/FM antenna

To assemble the AM loop antenna

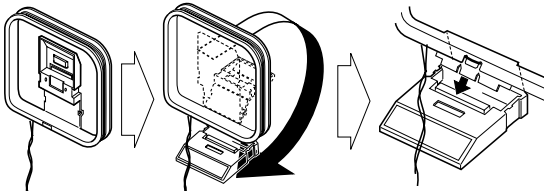

To connect AM/FM antenna

AM loop antenna (supplied)

Turn it until the best reception is obtained.

If the cords are covered with vinyl, remove the vinyl to expose the tip of the cord by twisting the vinyl.

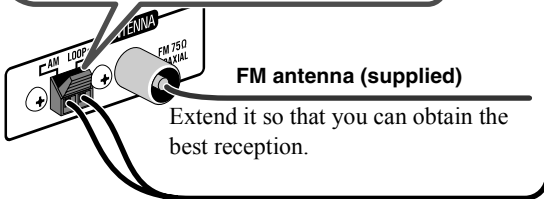
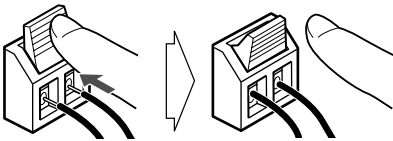

FM antenna (supplied)

Extend it so that you can obtain the best reception.

For better FM reception

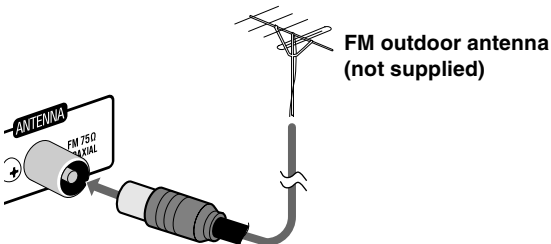

FM outdoor antenna (not supplied)

- Disconnect the supplied FM antenna, and connect to an outdoor FM antenna using a 75 Ω wire with coaxial type connector (IEC or DIN45325).

2 Speakers

- When connecting the speaker cords, match the polarity of the speaker terminals: red to (+) and black to (-).

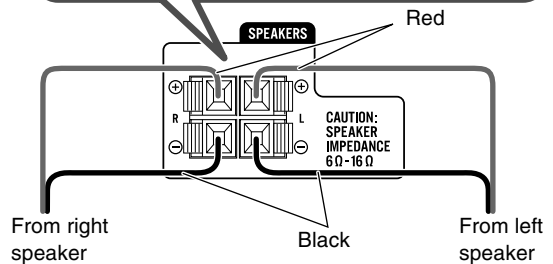
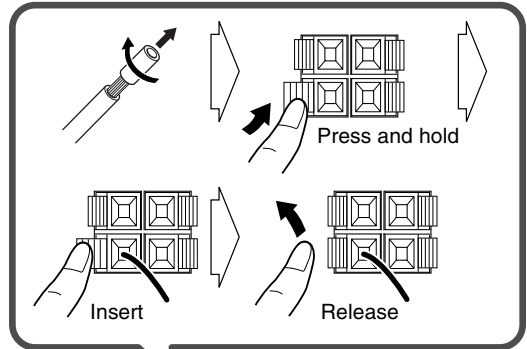

- DO NOT connect more than one speaker to each terminal.
- DO NOT push or pull the speakers as this will damage the foot spacers at the bottom of the speakers.



3 Digital audio component

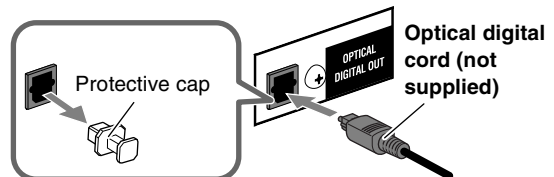

- Set "DIGITAL AUDIO OUTPUT" in the "AUDIO" menu correctly according to the connected digital audio equipment (see page 32).
- The digital signal through the OPTICAL DIGITAL OUT terminal is transmitted only when "DVD/CD" is selected as the source.

4 To connect the powered subwoofer

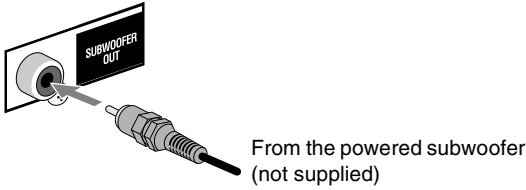

The connected subwoofer can reproduce the bass sounds recorded in front left and right channels, but cannot reproduce the LFE signals encoded in multi-channel software.

- Before plugging the System to the power supply, make sure that the powered subwoofer is turned off.

5 TV/monitor

Connect either component cord or SCART cord.

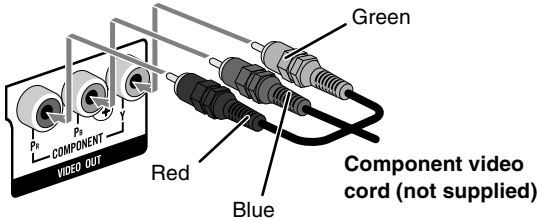

- This connection allows you to use the progressive scanning mode. To select progressive (PROGRESS) scanning mode (see page 14), use COMPONENT VIDEO OUT jacks.

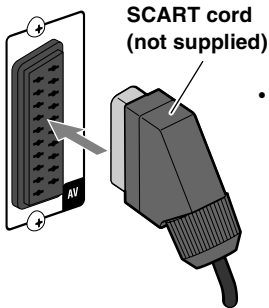

- This connection sends the video signal (Composite, Y/C, or RGB) and receives audio signal from TV. To listen to the TV sound, see page 9.

- After connecting a TV, select the appropriate video signal output according to the connection method. See “Changing the Scanning Mode” on page 14.

When connecting a USB mass storage class device

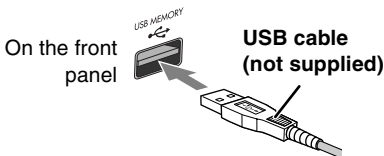

- When connecting with a USB cable, use the USB 2.0 cable whose length is less than 1 m.

- You can connect a USB mass storage class device such as a USB flash memory device, hard disk drive, multimedia card reader, etc. to this System.
- You cannot connect a computer to the USB MEMORY terminal of the System.

When connecting a digital audio player

- For listening to a digital audio player

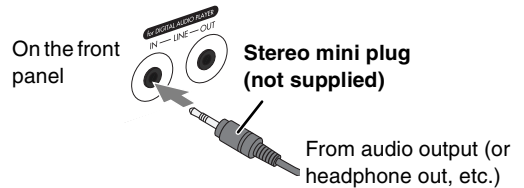

- For recording on a digital audio player

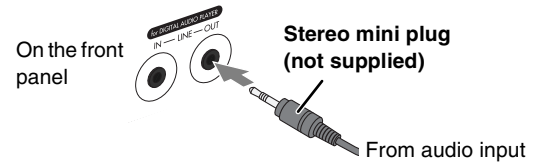

- Do not connect the same digital audio player to both the LINE IN and LINE OUT jacks at the same time; otherwise, the sound will be distorted.
- If an external device is not equipped with a stereo mini plug audio output, use a plug adapter to convert the stereo mini plug to the corresponding plug of the audio output.
- By using QP Link (Quick Portable Link), you can easily start playing back a digital audio player on this System. See page 11 for details.

Preparing the remote control

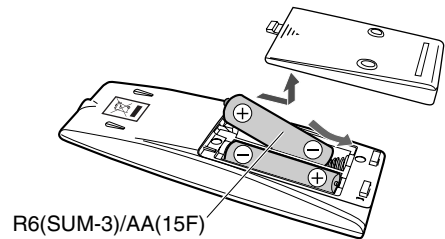

If the range or effectiveness of the remote control decreases, replace both batteries.

Caution

Do not expose batteries to heat or flame.

When using the remote control

Point the top of the remote control towards the remote sensor as directly as possible. If you operate it from a diagonal position, the operating range (approx. 5 m) may be shorter.

Display Indicators

The indications on the display tell you a lot of things while you are operating the System. Before operating the System, be familiar with when and how the indicators illuminate on the display.

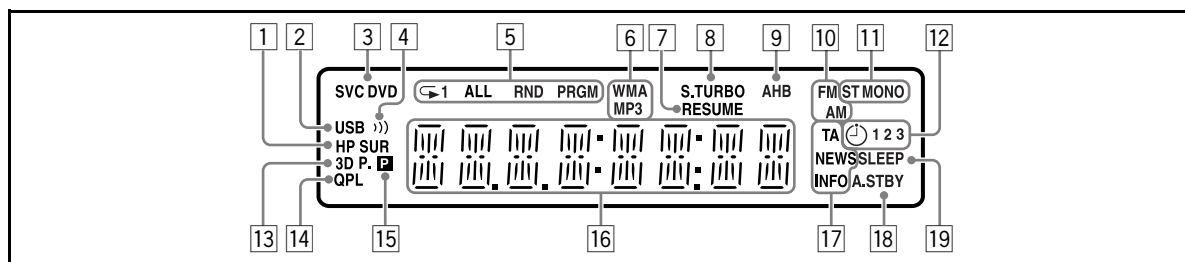

- 1 HP SUR (Headphone Surround) indicator
 - Lights when Headphone Surround is activated.
- 2 USB indicator
 - Lights when “USB MEM” is selected as the source.
- 3 Disc format indicators
 - SVCD: lights when playing back an SVCD.
 - VCD: lights when playing back a VCD.
 - CD: lights when playing back a CD.
 - DVD: lights when playing back a DVD.
- 4)) (Clear Voice) indicator
 - Lights when Clear Voice is activated.
- 5 Playback mode indicators
 - Repeat Mode indicators:
 - 1 : lights when One Track/File/Chapter/Step Repeat is activated.
 - : lights when One Group/Title/Program/Play List Repeat is activated.
 - ALL : lights when All Track/File/Title/Program Repeat is activated.
 - RND: lights when Random Play is activated.
 - PRGM: lights when Program Play is activated.
- 6 Audio format indicators
 - MP3: lights when an MP3 file is detected.
 - WMA: lights when a WMA file is detected.
- 7 RESUME indicator
 - Lights when the System memorizes the position where the playback is interrupted.
- 8 S.TURBO (Sound Turbo) indicator
 - Lights when Sound Turbo II is activated.
- 9 AHB indicator
 - Lights when AHB Pro (Active Hyper Bass Pro) is activated.
- 10 Radio band indicators
 - AM: lights when tuning in to an AM station.
 - FM: lights when tuning in to an FM station.
- 11 FM reception indicators
 - ST (stereo): lights while an FM stereo station with sufficient signal strength is tuned in.
 - MONO: lights while receiving an FM stereo station in monaural.
- 12 Daily Timer indicators
 - ☺ : lights when Daily Timer is on standby or is being set; flashes while it is working.
 - 1/2/3: lights when a Daily Timer (1, 2, or 3) is on standby or is working; flashes while being set.
- 13 3D P. indicator
 - Lights when 3D Phonic is activated.
- 14 QPL (Quick Portable Link) indicator
 - Lights when QP Link is activated.
- 15 P (Progressive) indicator
 - Lights when the progressive scanning mode is selected.
- 16 Main display
 - While listening to the radio: band (or preset number) and station frequency appear.
 - While “LINE” is selected: “LINE” appears.
 - While “TV SOUND” is selected: “TV SOUND” appears.
 - While playing a disc or file: current status appears.
- 17 Enhanced Other Networks indicators
 - TA/NEWS/INFO:
 - Lights to indicate the currently selected program type for PTY Standby Reception.
 - Flashes when a program is automatically tuned in with PTY Standby Reception.
- 18 A.STBY (Auto Standby) indicator
 - Lights when Auto Standby is activated.
 - Flashes when playback stops with Auto Standby activated.
- 19 SLEEP indicator
 - Lights when the Sleep Timer is activated.

Daily Operations—Playback

In this manual, operations using the remote control are mainly explained; however, you can use the buttons and controls on the main unit if they have the same (or similar) name and marks.

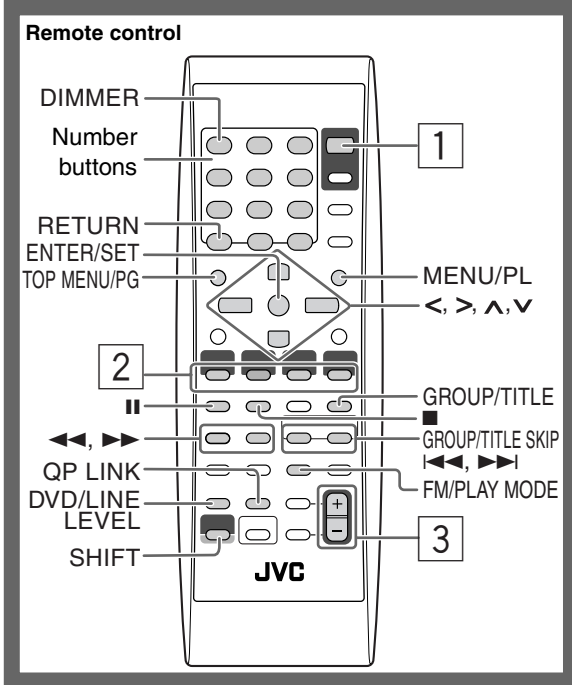

1 Turn on the power.

The STANDBY lamp on the main unit turns off.

- Instead of pressing AUDIO, the System is turned on by pressing one of the source buttons.
- When QP Link is activated, the System turns on and automatically changes the source to “LINE” as the source by starting playback on an external device. (See page 11 for details.)

2 Select the source.

- Playback automatically starts if the selected source is ready.
- You can change the display information by pressing DISPLAY. For details, see page 15.

3 Adjust the volume.

To turn off (standby) the System



The STANDBY lamp on the main unit lights in red.

- A small amount of power is always consumed even while on standby.

You can reduce power consumption by turning off the display. To turn off the display, select “DISP OFF” by pressing DIMMER (while holding SHIFT) when on standby.

- To restore the display indication, select “DISP ON” by pressing DIMMER (while holding SHIFT) again.

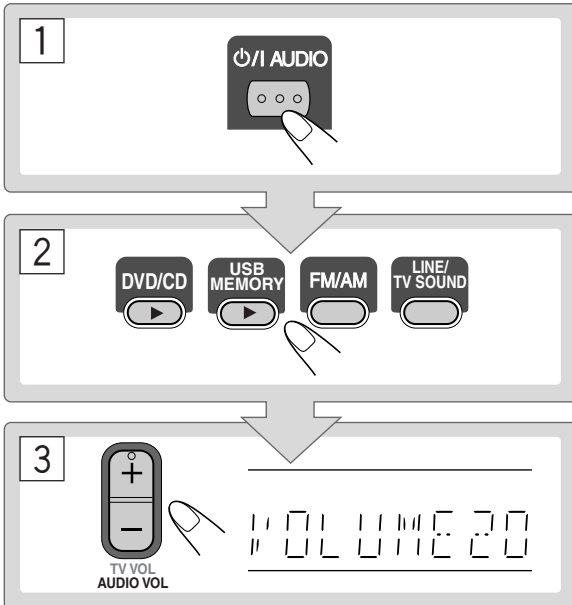

For private listening

Connect a pair of headphones to the PHONES jack on the main unit. The sound will no longer come out of the speakers. **Be sure to turn down the volume before connecting or putting on the headphones.**

- Disconnecting the headphones will activate the speakers again.



DO NOT turn off (standby) the System with the volume set at an extremely high level; otherwise, the sudden blast of sound may damage your hearing, speakers and/or headphones when you turn on the System or start playback.

How to select a number



Examples:

To select number 5, press 5.

To select number 10, press 10.

To select number 15, press ≥ 10 , 1, 5.

To select number 30, press ≥ 10 , 3, then 0.

To select number 125, press ≥ 10 , ≥ 10 , 1, 2, then 5.

Listening to the Radio INFO

To select the band (FM or AM)

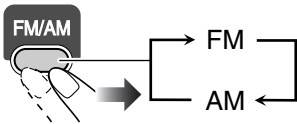

To tune in to a station

While FM or AM is selected...

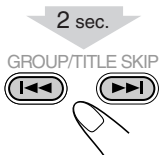

Frequency starts changing on the display.

When a station (frequency) with sufficient signal strength is tuned in, the frequency stops changing.

- When you repeatedly press the button, the frequency changes step by step.

To manually stop the search, press either button.

If the FM reception is poor

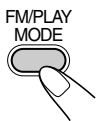

The MONO indicator lights on the display. Reception will improve though stereo effect is lost—Monaural reception.

To restore the stereo effect, press the button again (the MONO indicator disappears).

If the beats are heard while listening to AM station

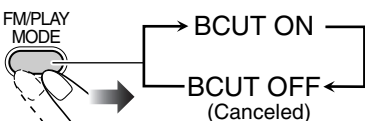

- If you change to another station, this setting is automatically canceled.

To preset the stations



You can preset 30 FM and 15 AM stations.

1 Tune in to a station you want to preset.

- You can also store the monaural reception mode for FM preset stations if it is selected.

2 Activate the preset number entry mode.

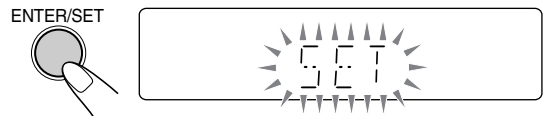

- Finish the following process while the indication on the display is flashing.

3 Select a preset number for the station you store.



- To select a number, see “How to select a number” on the left column.

- You can also use the $\blacktriangleright\blacktriangleright$ or $\blacktriangleleft\blacktriangleleft$ button.

4 Store the station.

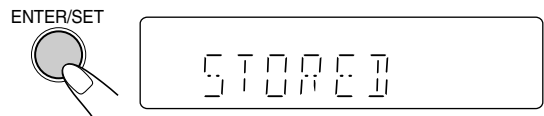

To tune in to a preset station



1 Select the band (FM or AM).

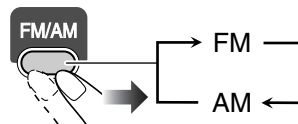

2 Select the preset number for the station you stored.

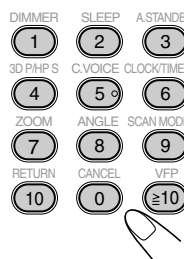

- To select a number, see “How to select a number” on the left column.

- You can also use the $\blacktriangleright\blacktriangleright$ or $\blacktriangleleft\blacktriangleleft$ button.

Listening to the TV Sound

You can listen to the TV sound through this System when the TV is connected using the SCART cable (see page 5).

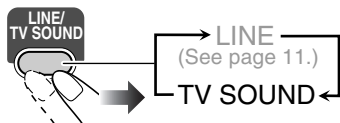

Playing Back a Disc/USB mass storage class device

To insert a disc

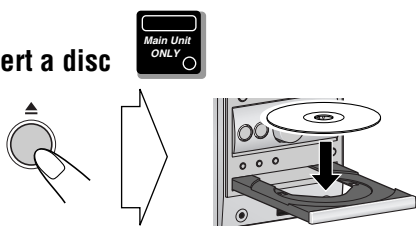

- When using an 8 cm disc, place it on the inner circle of the disc tray.

To close the disc tray, press ▲ again.

- If you press DVD/CD ►, disc tray closes automatically and playback starts (depending on how the disc is programmed internally).

To connect a USB mass storage class device

- For connecting a USB mass storage class device, see page 5.
- Always set volume level to the minimum level when connecting or disconnecting a USB mass storage class device.
- To disconnect a USB mass storage class device safely, turn off the System before disconnecting it.

To play back a disc/USB mass storage class device

To start:	
Disc 	USB mass storage class device
To pause: 	To stop:
To release, press DVD/CD ► or USB MEMORY ►.	

- For MP3/WMA/WAV/JPEG/MPEG-1/MPEG-2/DivX files:
 - If different types of playable files (audio/still picture/moving picture) are recorded on a disc or USB mass storage class device, select a file type to play (see “FILE TYPE” in “PICTURE” menu on page 31).
 - When the System detects MP3/WMA/WAV/JPEG/MPEG-1/MPEG-2/DivX files, the control screen appears on the TV. (For still/moving picture files, it appears while playback is stopped.) For details, see page 28.
- The System can store the stop point, and when you start playback again by pressing DVD/CD ► or USB MEMORY ► (even while on standby), it starts from the position where you have stopped—Resume Play. (RESUME indicator lights on the display when you stop playback.)
 - To stop completely while Resume is activated**, press ■ twice. (To cancel Resume, see “RESUME” in “OTHERS” menu on page 32.)

On-screen guide icons

- During playback, the following icons may appear on the TV:

	At the beginning of a scene containing multi-angle views.
	At the beginning of a scene containing multi-audio sounds.
	At the beginning of a scene containing multi-subtitles.

- The following icons will also be shown on the TV to indicate your current operation.



- To deactivate the on-screen guide icon, see “ON SCREEN GUIDE” in “OTHERS” menu on page 32.

To select a title/group



While playing...

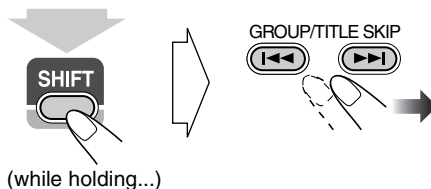

- You can select a title/group directly by pressing the number buttons after pressing GROUP/TITLE (not applicable for DVD-VR). To select a number, see “How to select a number” on page 8.

To select a chapter/track/file

- For VCD/SVCD, cancel PBC (see the right column).

While playing...



- When you press **◀◀** for the first time, you will go back to the beginning of the current chapter/track/file.

To locate a particular portion

- This does not function for JPEG files.

While playing...



- For MP3/WMA/WAV/DivX files, the search speed and indications on the TV are different from those above.
- No sound comes out if searching is carried out while showing the moving picture.

To return to normal playback, press DVD/CD **▶** or USB MEMORY **▶** (depending on the current source).

- For DivX/MPEG-1/MPEG2 files, each time you press the **>** or **<** button, you can skip to a scene by 30 seconds or 5 minutes depending on the files.

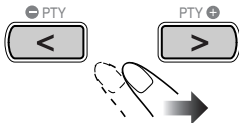

To locate an item directly

You can select a title/chapter/track/file directly and start playback.

- For DVD Video, you can select a **title before starting playback**, while you can select a **chapter after starting playback**.



- To select a number, see “How to select a number” on page 8.

To play back using the disc menu



- For DVD Video:**

1 Show the disc menu.



2 Select an item on the disc menu.

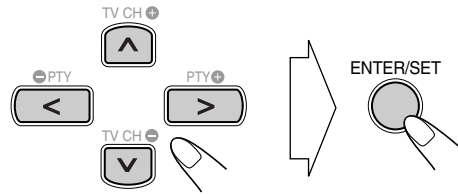

- For some discs, you can also select items by entering the number using the number buttons.

- For SVCD/VCD with PBC:**

While playing a disc with PBC, “PBC” appears on the display.

When disc menu appears on the TV, select an item on the menu. Playback of the selected item starts.



- To select a number, see “How to select a number” on page 8.

To move to the next or previous page of the current menu:

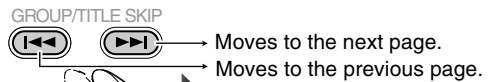

To return to the previous menu:

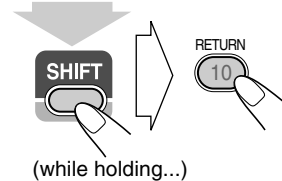

To cancel PBC, press **■**, then select a track by using the number buttons (see page 8). Playback starts with the selected track.

To reactivate PBC, press **■** (twice if Resume is turned “ON”), then press DVD/CD **▶**.

Playing Back a Digital Audio Player INFO

- For connecting a digital audio player, see page 5.

To listen to digital audio player

You can listen to the digital audio player connected to the LINE IN jack.

- Make sure to turn down the volume on the System to minimum level before starting playback.

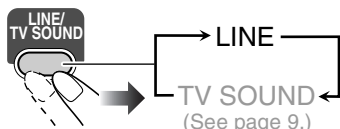

To adjust the audio input level Remote ONLY

If the sound from the device connected to the LINE IN jack is too loud or too quiet, you can change the audio input level through the LINE IN jack (without changing the volume level).

While “LINE” is selected as a source...

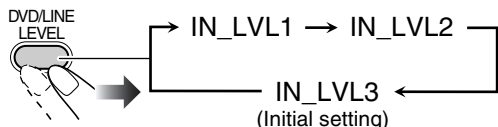

- As the number of the level increases, the input level is increased.

To activate QP Link Remote ONLY

By using QP Link (Quick Portable Link), you can easily start playing back a digital audio player connected to the LINE IN jack.

- Make sure to set the volume of your digital audio player loud enough so that the System can detect the sound signal.

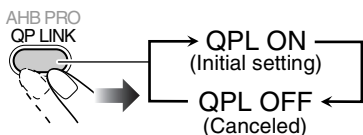

When QP Link is activated, connecting a digital audio player to the LINE IN jack and starting playback performs the following:

- While the System is turned on...
Changes the source to “LINE” automatically. (If you change from “LINE” to another source, QP Link will be canceled.)
- While the System is on standby...
Turns on the System and automatically changes the source to “LINE,” except when the display is turned off (see page 7).

While QP Link is playing the device...

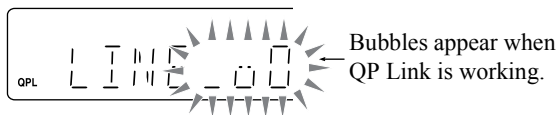

Bubbles appear when QP Link is working.

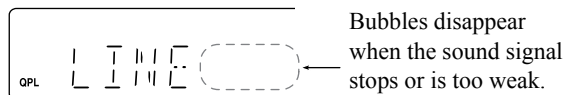

Bubbles disappear when the sound signal stops or is too weak.

To record on a digital audio player

You can record the sound from the System to the digital audio player connected to the LINE OUT jack.

IMPORTANT:

It should be noted that it may be unlawful to re-record pre-recorded tapes, records, or discs without the consent of the owner of copyright in the sound or video recording, broadcast or cable program and in any literary, dramatic, musical, or artistic work embodied therein.

- 1 Start recording on the digital audio player.
- 2 Start playing the disc, USB mass storage class device, or tune in to the station you want to record.

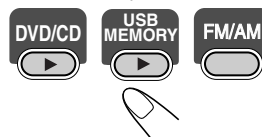

- Before recording on a digital audio player, deactivate QP Link or do not connect the digital audio player to the LINE IN jack; otherwise, “LINE” will be selected as the source and the recording will stop.
- Sound adjustments (see pages 12 and 13) do not affect recording on the digital audio player.

To adjust the audio output level Remote ONLY

If the recorded sound on the digital audio player connected to the LINE OUT jack is too loud or too quiet, you can change the audio output level through the LINE OUT jack (without changing the volume level).

While “LINE” is selected as a source...

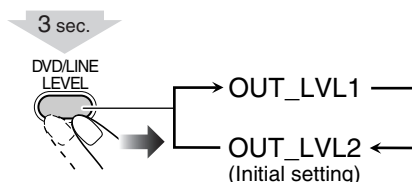

- As the number of the level increases, the output level is increased.

Daily Operations—Sound & Other Adjustments

Remote control

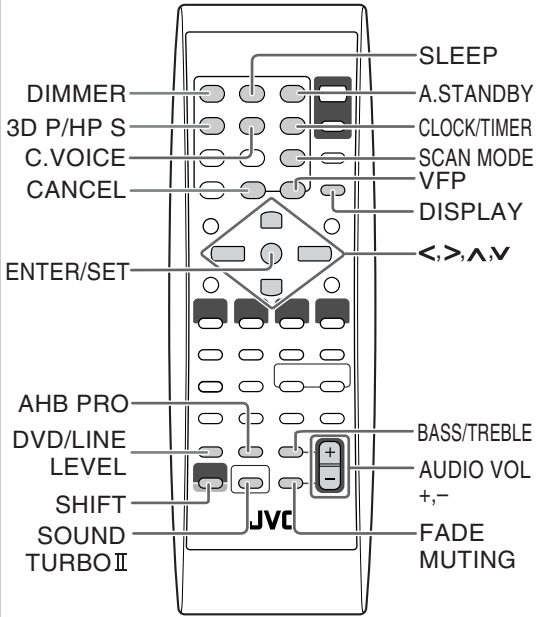

Main unit

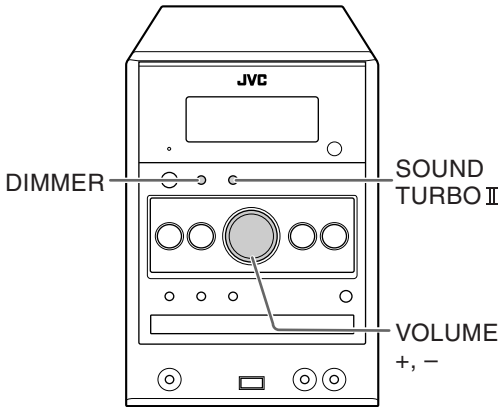

Adjusting the Volume

You can adjust the volume level from VOL MIN to level 40 (VOL MAX).

Remote control:	Main unit:

To drop the volume in a moment



To restore the volume, press again, or adjust the volume level.

Adjusting the Sound



To reinforce the heavy sound

This boosts the low and high frequency sound—Sound Turbo II.

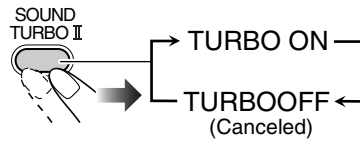

- When Sound Turbo II is turned on:
 - AHB Pro (see below) is automatically turned on, and cannot be turned off. (The AHB indicator does not light even though the function is turned on.)
 - The bass and treble level (see below) is set to “+2.”

To reinforce the bass sound



While Sound Turbo II is off, the richness and fullness of the bass sound is clearly maintained regardless of how you set the volume—AHB Pro (Active Hyper Bass Pro).

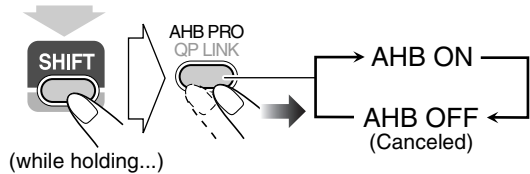

To adjust the tone



You can adjust the bass and treble level from -3 to +3.

To adjust the bass

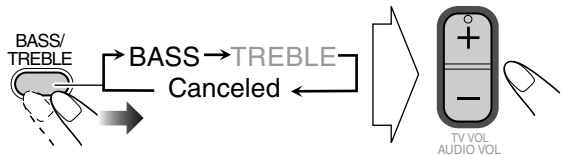

To adjust the treble

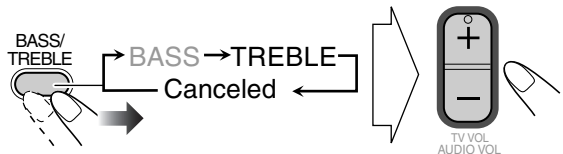

Creating 3-Dimensional Sound Field

3D Phonic

- This only functions while listening to disc/USB mass storage class device.
- This does not function for MPEG-1/MPEG-2/DivX files.

While playing...

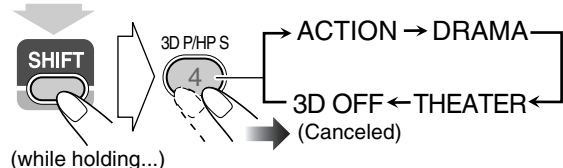

ACTION	Suitable for action movies and sports programs.
DRAMA	Creates natural and warm sound. Enjoy movies in a relaxed mood.
THEATER	Enjoy sound effects like in a major theater.

Using Headphone Surround

You can enjoy a surround effect while listening through headphones.

- This only functions while listening to disc/USB mass storage class device playback.
- This does not function for MPEG-1/MPEG-2/DivX files.

While playing...

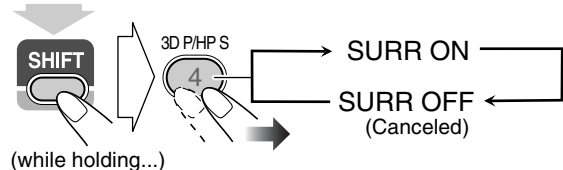

- If you plug in the headphones while 3D Phonic is in use, Headphone Surround is turned on automatically.
- When 3D Phonic is not in use and Headphone Surround is turned on, unplugging the headphones turns 3D Phonic to "ACTION."

Making Dialogues Clear—Clear Voice

When you play back a disc or USB mass storage class device, you can make the singer's voices or dialogues of the movie clear—Clear Voice. When Clear Voice is in use, the  (Clear Voice) indicator lights on the display.

- This function works for multi-channel software which contains a center channel signal and for 2-channel software with 3D Phonic activated.

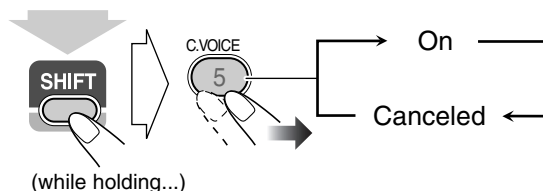

Presetting Automatic DVD Sound

Increase Level

DVD sound is sometimes recorded at a lower level than other discs and sources. You can set the increase level for the currently loaded DVD, so you do not have to adjust the volume when you change the source.

- This only functions for DVD Video and DVD-VR.

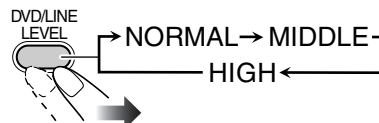

NORMAL	Original recording level.
MIDDLE	Output level is increased (less than "HIGH").
HIGH	Output level is increased (more than "MIDDLE"). (initial setting)

Changing the Display Brightness

You can dim the display window.

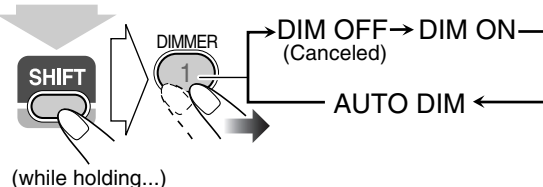

DIM ON	Dims the display.
AUTO DIM	Dims the display during playback of still/moving pictures.

- Dimmer is canceled when playback stops.

Changing the Scanning Mode Remote ONLY **INFO**

This System supports progressive scanning. Select the video signal output according to the type of your TV. If you connect a progressive TV through the COMPONENT VIDEO OUT jacks, you can enjoy a high quality picture playback by selecting "PROGRESS."

Before playback...

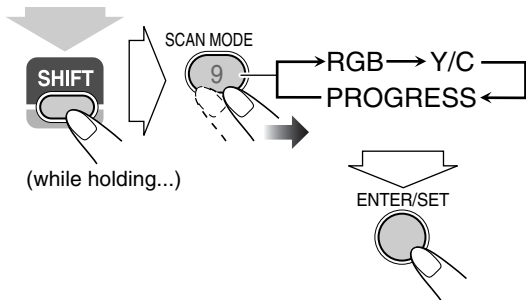

RGB	For a conventional TV. Select to send the composite video signals or RGB signals through the AV (SCART) terminal.
Y/C	For a conventional TV. Select to send S-Video signals through the AV (SCART) terminal.
PROGRESS	For a progressive TV. Select to enjoy a progressive scanned picture through the COMPONENT VIDEO OUT jacks. • The P (Progressive) indicator lights on the display.

Changing the Picture Tone Remote ONLY

While showing a playback picture on the TV, you can select a preset picture tone, or adjust it and store your own preference.

To select a preset picture tone

1 While playing, display VFP setting screen.

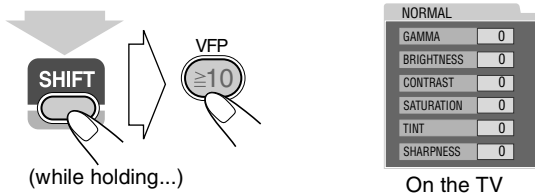

2 Select a preset picture tone.

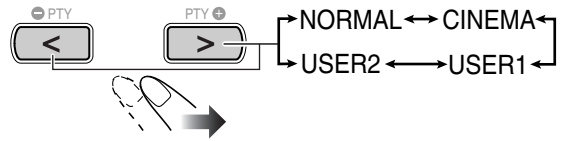

NORMAL	Normally select this.
CINEMA	Suitable for a movie source.
USER1/USER2	You can adjust parameters and can store the settings.

To clear the screen, press VFP again while holding SHIFT.

To adjust the picture tone

1 Select "USER1" or "USER2."

• Follow steps **1** and **2** explained in "To select a preset picture tone."

2 Select a parameter you want to adjust.

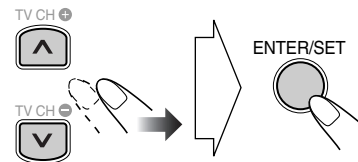

GAMMA	Adjust if the neutral color is bright or dark (-3 to +3).
BRIGHTNESS	Adjust if the entire picture is bright or dark (-8 to +8).
CONTRAST	Adjust if the brightness ratio is unnatural (-7 to +7).
SATURATION	Adjust if the picture is whitish or blackish (-7 to +7).
TINT	Adjust if the human skin color is unnatural (-7 to +7).
SHARPNESS	Adjust if the picture is indistinct (-8 to +8).

3 Adjust the parameter.

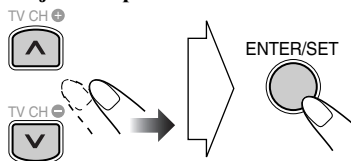

4 Repeat steps **2** and **3** to adjust other parameters.

To clear the screen, press VFP again while holding SHIFT.

Setting the Clock

Without setting the built-in clock, you cannot use Daily Timers (see page 29).

- To exit the clock settings, press CLOCK/TIMER (while holding SHIFT) as required.
- To correct a mis-entry during the process, press CANCEL (while holding SHIFT). You can return to the previous step.

1 Activate the clock setting mode.

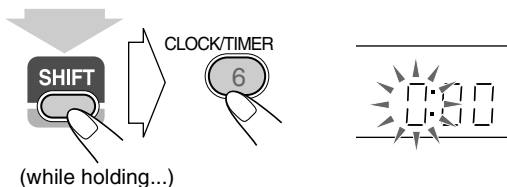

- If you have already adjusted the clock before, press the button repeatedly until the clock setting mode is selected.

2 Adjust the hour, then the minute.

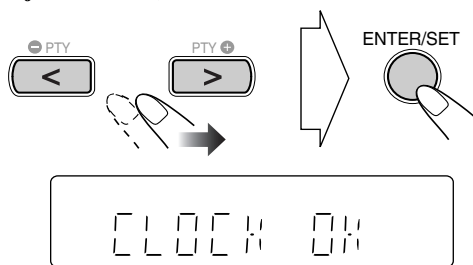

Now the built-in clock starts working.

To check the current clock time during playback

Ex.: While playing a disc...

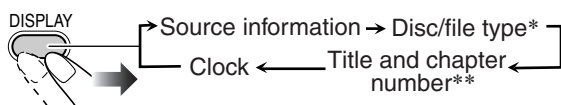

- * Only while playing back a disc or USB mass storage class device.
- ** Only while playing back the following discs/files:
 DVD-VR: Program number/Play List number and chapter number.
 MP3/WMA/WAV/JPEG/MPEG-1/MPEG-2/DivX files: Group and file number.
 DVD Video: Title and chapter number.

Turning Off the Power Automatically

Auto Standby

- This only functions while playing a disc/USB mass storage class device/digital audio player (with QP Link activated).

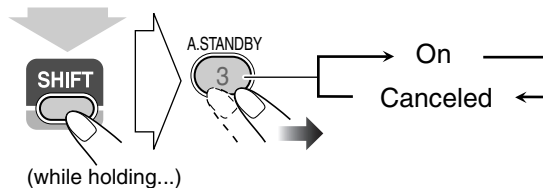

When Auto Standby is in use, the A.STBY indicator lights on the display.

When the playback stops, the A.STBY indicator starts flashing. If no operation is done for about 3 minutes while the indicator is flashing, the System turns off (standby) automatically.

- Auto Standby works for “DVD/CD,” “USB MEM” and “LINE.”
- Changing the source to “FM,” “AM” or “TV SOUND” temporarily deactivates Auto Standby.

Sleep Timer

You can set the shut-off time so that you can go to bed without turning off the System yourself.

1 Specify the time (in minutes).

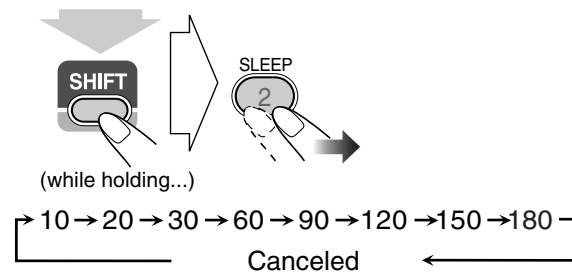

2 Wait until the set time disappears.

To check the time remaining until the shut-off time, press SLEEP while holding SHIFT.

- If you press the button repeatedly, you can change the shut-off time.

Advanced Radio Operations INFO

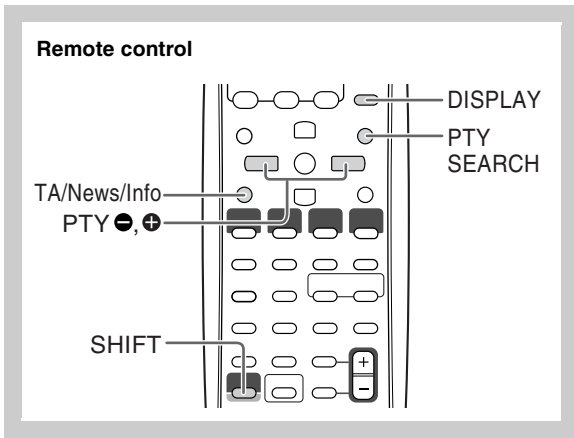

Receiving FM Stations with Radio Data System

System

Radio Data System allows FM stations to send an additional signal along with their regular program signals.

This System can receive the following types of Radio Data System signals.

PS (Program Service)	Shows commonly known station names.
PTY (Program Type)	Shows types of broadcast programs.
RT (Radio Text)	Shows text messages the station sends.
Enhanced Other Networks	Provides information about the types of the programs broadcast by the Radio Data System stations of the different networks.

To show the Radio Data System information

While listening to an FM station...

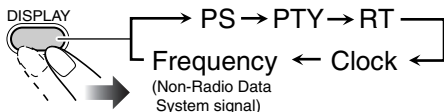

PS	Station names are displayed. "NO PS" will appear if no signal is sent.
PTY	The broadcast program type is displayed. "NO PTY" will appear if no signal is sent.
RT	Text messages the station sends are displayed. "NO RT" will appear if no signal is sent.

Searching for a Program by

PTY Codes

You can locate a particular kind of program from the preset channels (see page 8) by specifying the PTY codes.

To search for a program using the PTY codes

1 While listening to an FM station...

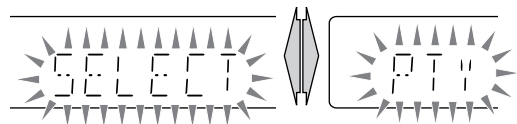
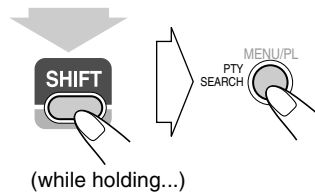

2 Select a PTY code (see page 17).

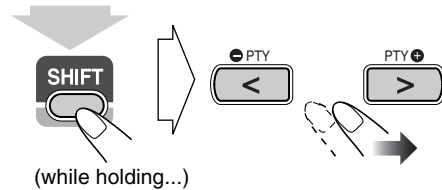

3 Start searching.

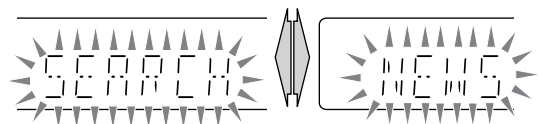
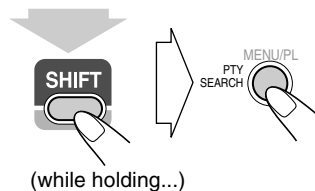

Ex. When "NEWS" is selected

The System searches for 30 preset FM stations, stops when it finds the one you have selected, and tunes in to that station.

- If no program is found, "NOTFOUND" appears on the display.
- To stop searching any time during search, press PTY SEARCH (while holding SHIFT).

To continue searching after it stops on an unwanted station

While the indications on the display are flashing, press PTY SEARCH again (while holding SHIFT).

Switching Temporarily to a Program of Your Choice Automatically



The Enhanced Other Networks function allows the System to switch temporarily to a preset FM station broadcasting a program of your choice (TA, NEWS, or INFO).

- This function works while listening to an FM station providing the required signals.

While listening to an FM station, select the program type.

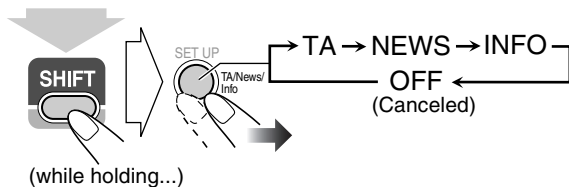

TA	Traffic announcement in your area
NEWS	News
INFO	Program the purpose of which is to impart advice in the widest sense

How the Enhanced Other Networks function works:

CASE 1

If a station is not broadcasting the program of your choice

The System continues tuning in to the current station.

When a station starts broadcasting the program of your choice, the System automatically switches to that station. The Enhanced Other Networks indicator starts flashing.

When the program is over, the System goes back to the previously tuned station, but the function still remains active (the indicator stops flashing and remains lit).

CASE 2

If a station is broadcasting the program of your choice

The System automatically switches to the station. The Enhanced Other Networks indicator starts flashing.

When the program is over, the System goes back to the previously tuned station, but the function still remains active (the indicator stops flashing and remains lit).

CASE 3

If the station currently tuned in is broadcasting the program of your choice

The Enhanced Other Networks indicator starts flashing.

When the program is over, the indicator stops flashing (the function still remains active).

Description of the PTY codes

NEWS:	News.
AFFAIRS:	Topical program expanding or enlarging upon the news—debate, or analysis.
INFO:	Programs the purpose of which is to impart advice in the widest sense.
SPORT:	Programs concerned with any aspect of sports.
EDUCATE:	Educational programs.
DRAMA:	All radio plays and serials.
CULTURE:	Programs concerning any aspect of national or regional culture, including language, theater, etc.
SCIENCE:	Programs about natural sciences and technology.
VARIED:	Used for mainly speech-based programs such as quizzes, panel games and personality interviews.
POP M:	Commercial music of current popular appeal.
ROCK M:	Rock music.
EASY M:	Current contemporary music considered to be “easy-listening”.
LIGHT M:	Instrumental music, and vocal or choral works.
CLASSICS:	Performances of major orchestral works, symphonies, chamber music, etc.
OTHER M:	Music not fitting into any of the other categories.
WEATHER:	Weather reports and forecasts.
FINANCE:	Stock Market reports, commerce, trading etc.
CHILDREN:	Programs targeted at a young audience.
SOCIAL:	Programs about sociology, history, geography, psychology and society.
RELIGION:	Religious programs.
PHONE IN:	Involving members of the public expressing their views either by phone or at a public forum.
TRAVEL:	Travel information.
LEISURE:	Programs about recreational activities.
JAZZ:	Jazz music.
COUNTRY:	Songs which originate from, or continue the musical tradition of the American Southern States.
NATION M:	Current popular music of the nation or region in that country’s language.
OLDIES:	Music from the so-called “golden age” of popular music.
FOLK M:	Music which has its roots in the musical culture of a particular nation.
DOCUMENT:	Programs concerning factual matters, presented in an investigative style.
TEST:	Broadcasts for testing emergency broadcast equipment or unit.
ALARM:	Emergency announcement.
NONE:	No program type, undefined program, or difficult to categorize into particular types.

- Classification of the PTY codes for some FM stations may be different from the above list.

Unique Video Disc/File Operations

Remote control

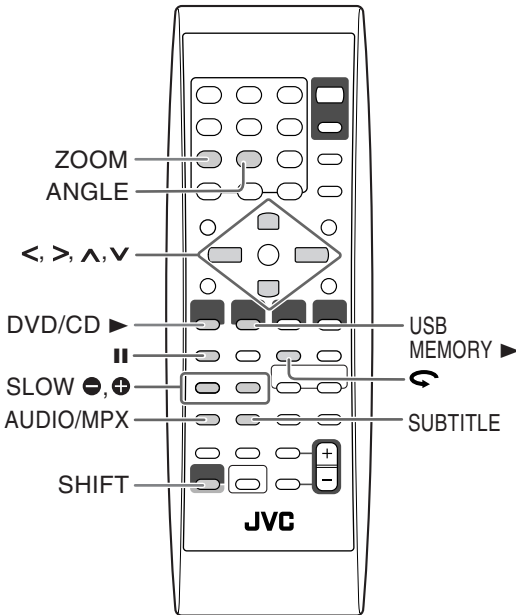

Selecting the Audio Track



For DivX files/DVD Video: While playing back a chapter/file containing several audio languages, you can select the language to listen to.

For DVD-VR/SVCD/VCD: While playing back a track, you can select the audio channel to listen to.

- For DVD Video/DVD-VR/SVCD/VCD: You can also select the audio track using the on-screen bar (see page 24).



While playing a DVD Video...

Ex.:

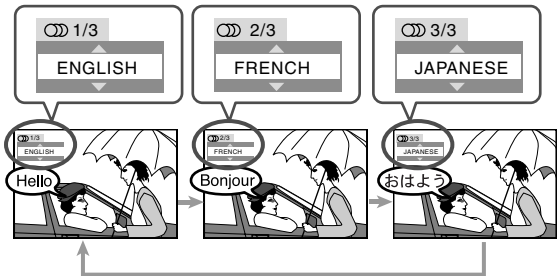

While playing a DivX file...

Ex.:

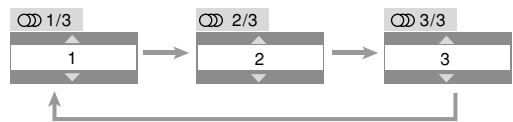

While playing a DVD-VR or SVCD/VCD...

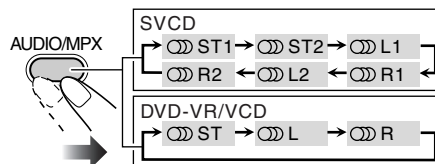

ST1/ST2/ To listen to normal stereo
ST (2-channel) playback.

L1/L2/L To listen to the left audio channel.

R1/R2/R To listen to the right audio channel.

- SVCD can have 4 audio channels. SVCD usually uses these 4 channels to record two 2-channel recordings (ST1/ST2).

Selecting the Subtitle Language

For DivX files/DVD Video: While playing back a chapter/file containing subtitles in different languages, you can select the subtitle language to display on the TV.

For DVD-VR: While playing, you can turn the subtitles on or off.

For SVCD: While playing, you can select the subtitles even if no subtitles are recorded on the disc.

- For DVD Video/DVD-VR/SVCD: You can also select the subtitle language using the on-screen bar (see page 24).

While playing a DivX file/DVD Video...

1

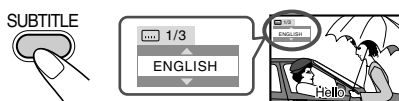

2

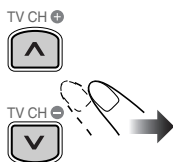

Ex.:

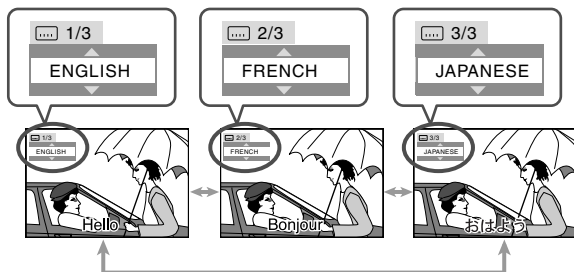

While playing a DVD-VR...

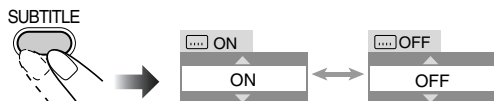

While playing an SVCD...

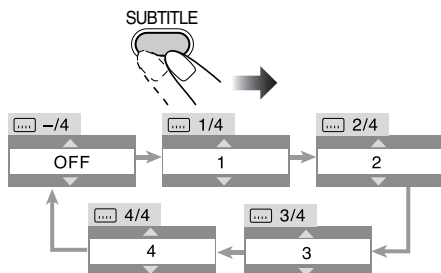

Selecting the View Angle

For DVD Video only: While playing back a chapter containing multi-view angles, you can view the same scene from different angles.

- You can also select the multi-view angles using the on-screen bar (see page 24).

While playing...

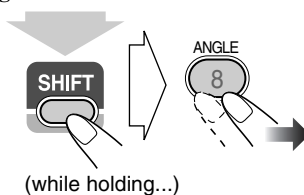

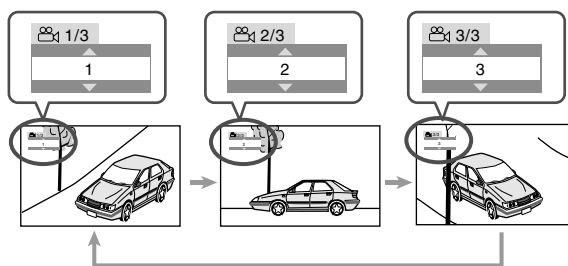

Ex.:



Special Effect Playback INFO

Still picture playback

To display the still picture:	To resume normal playback:
While playing... 	Disc  

Frame-by-frame playback Remote ONLY



1 While playing...



Still picture playback starts.

2 Advance the still picture frame by frame.



To resume normal playback, press DVD/CD  or USB MEMORY  (depending on the current source).

Slow-motion playback Remote ONLY

This function is used only while playing DVD Video/DVD-VR/SVCD/VCD.

1 While playing...



Still picture playback starts.

2 Select slow motion speed.

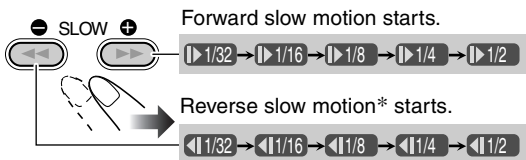

* Only available for DVD Video.

To resume normal playback, press DVD/CD .

To replay the previous scenes (One-Touch Replay) Remote ONLY

This function is only used while playing DVD Video/DVD-VR.

While playing....



The playback position moves back about 10 seconds before the current position (only within the same title).

Zoom Remote ONLY

1 While playing...

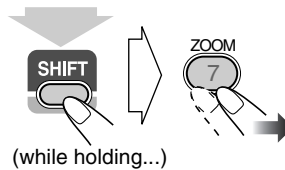

While playing a DVD Video/DVD-VR/SVCD/VCD and MPEG-1/MPEG-2/DivX file:

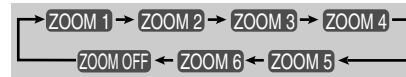

While playing a JPEG file (not available during slide-show):

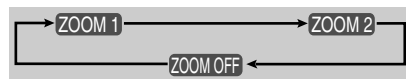

2 Move the zoomed-in position.

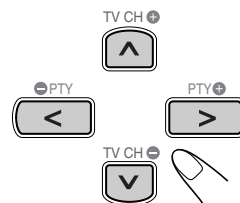

To cancel Zoom, press ZOOM (while holding SHIFT) repeatedly until "ZOOM OFF" appears on the TV.

Advanced Playback Operations

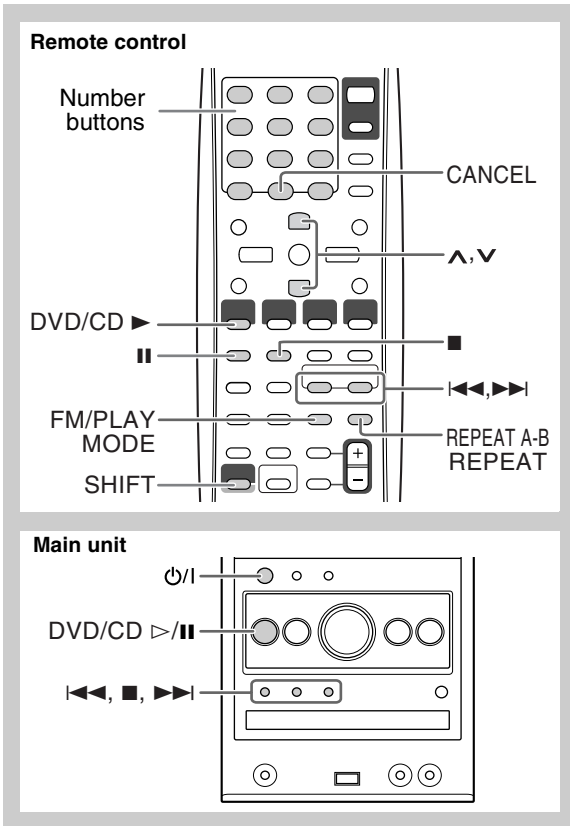

2 Select chapters/tracks/files you want for Program Play.

- ① For DVD Video and MP3/WMA/WAV files: Select a title or group number.
- ② Select a chapter or track/file number.
 - To select a number, see “How to select a number” on page 8.

3 Repeat step 2 until you complete your program.

4 Start playback.



Playback starts in the order you have programmed.



To check the programmed contents

Before or after playback...

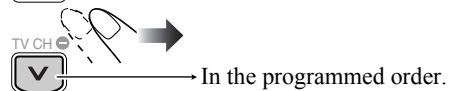
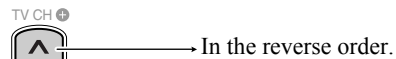

- You can also use ◀◀ or ▶▶ to check the programmed contents.

Programming the Playing Order



You can arrange the playing order of the chapters/tracks/files (up to 99) before you start playback.

- Program play cannot be used for the USB mass storage class device, DVD-VR and JPEG/MPEG-1/MPEG-2/DivX files on a disc.
- Resume does not work for Program Play.

1 Before starting playback, activate Program Play.

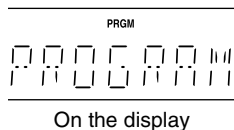
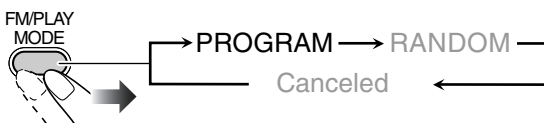

PROGRAM		
No	Group/Title	Track/Chapter
1		
2		
3		
4		
5		
6		
7		
8		
9		
10		

On the TV

To modify the program

Before or after playback...

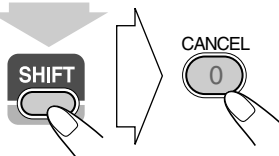
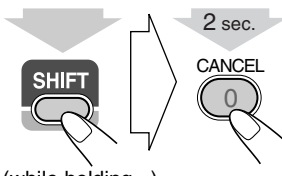
To erase the last step:  (while holding...)	
To erase the entire program:  (while holding...)	To add another step in the program: Repeat step 2 on page 21.

To exit Program Play

Before or after playback...

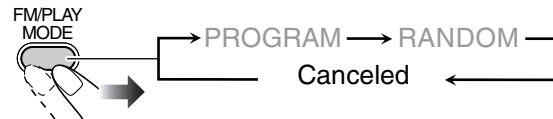

Playing at Random—Random Play

You can play all chapters or tracks at random.

- Random Play cannot be used for the USB mass storage class device, DVD-VR and JPEG/MPEG-1/MPEG-2/DivX files on a disc.

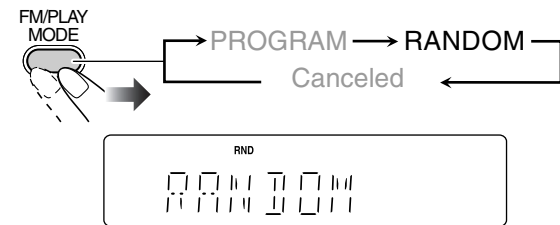

1 Before starting playback, activate Random Play.



2 Start playback.

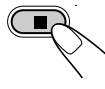

Playback starts in random order.
Random Play ends when the entire disc has been played.

To skip a chapter/track: 	To pause:  To release, press DVD/CD ►.	To stop: 
--	---	--

To exit Random Play

Before or after playback...

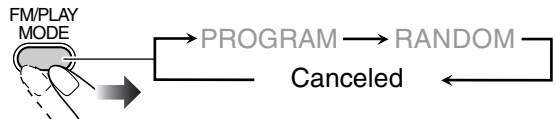

Playing Repeatedly

- For DVD Video/DVD-VR/SVCD/VCD/CD: You can also select the repeat mode using the on-screen bar (see pages 25 and 26).

Repeat Play

You can repeat playback.

- **For DVD Video:**

While playing...

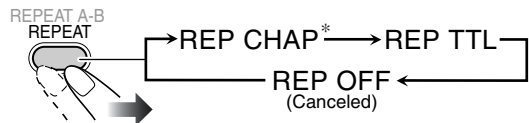

- **For CD/SVCD/VCD:**

While playing (without PBC for SVCD/VCD) or before playback...

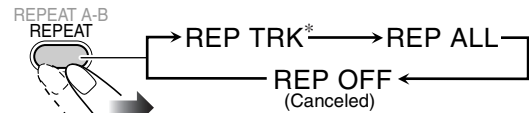

* See the next page.

Continued on the next page

• **For DVD-VR:**

While playing an Original Program...

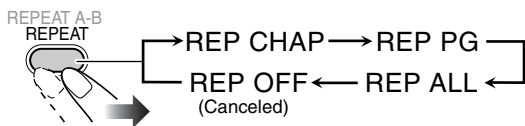

While playing a Play List...

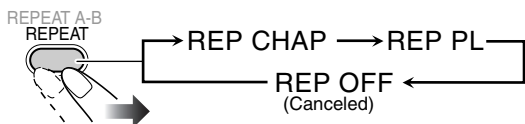

• **For MPEG-1/MPEG-2/DivX/MP3/WMA/WAV files:**

While playing or before playback...

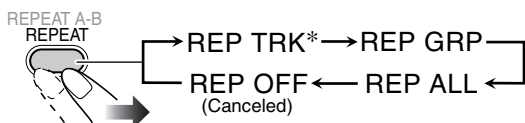

• **For JPEG files during slide-show:**

While playing or before playback...

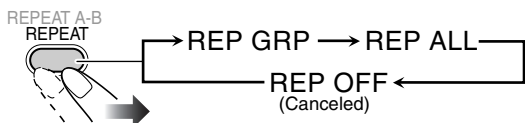

REP CHAP*	Repeats the current chapter.
REP TTL	Repeats the current title.
REP TRK*	Repeats the current track/file.
REP GRP	Repeats the current group.
REP PG	Repeats the current program.
REP PL	Repeats the current Play List.
REP ALL	Repeats all the contents or programmed tracks/files.

* During Program Play and Random Play, “REP STEP” appears instead of these indications, and the repeat mode changes as follows for all discs.

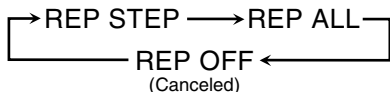

A-B Repeat

You can repeat playback of a desired portion by specifying the beginning (point A) and the ending (point B).

- A-B Repeat cannot be used for MP3/WMA/WAV/JPEG/MPEG-1/MPEG-2/DivX files and some DVDs.

1 While playing (without PBC for SVCD/VCD), select the start point (A).

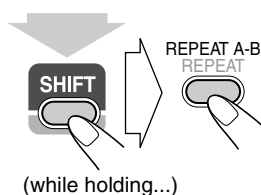

- starts flashing on the display.
- appears on the TV if the TV is turned on.

2 Select the end point (B).

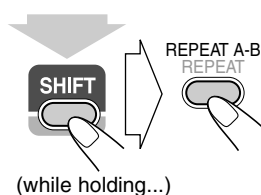

- stops flashing.
- appears on the TV.
- You can search for the end point using the ►► button.

To cancel A-B Repeat, press REPEAT A-B again while holding SHIFT.

- A-B Repeat will also be canceled when you stop play or skip the chapter or track.

Prohibiting Disc Ejection—Child Lock



You can lock the disc tray so that no one can eject the loaded disc.

- This function is available only while the System is on standby.

While the disc tray is closed...

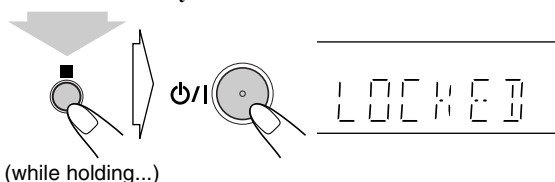

To cancel the prohibition, repeat the same procedure. “UNLOCKED” appears on the display.

On-Screen Operations

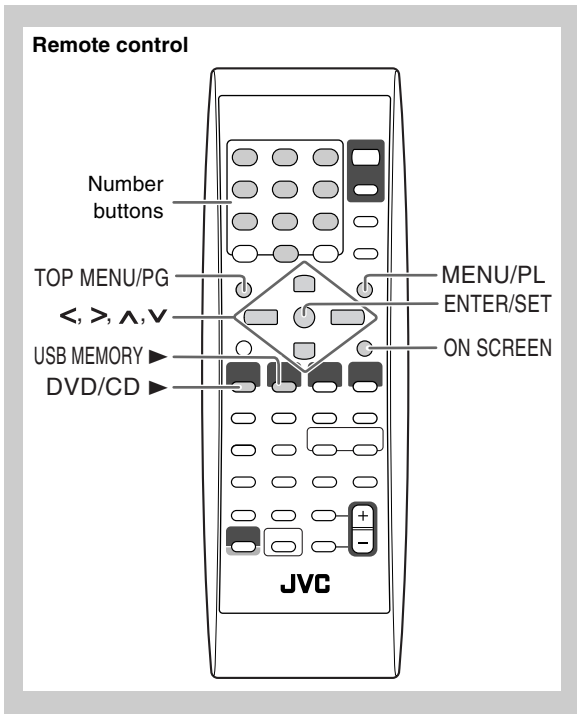

On-screen Bar Operations Remote ONLY INFO

You can check the source information (disc/USB mass storage class device) and playback status by using the on-screen bar (not applicable for MP3/WMA/WAV/JPEG files). You can also use some functions when playing back DVD Video/DVD-VR/SVCD/VCD/CD.

On-screen Bar Information

DVD Video

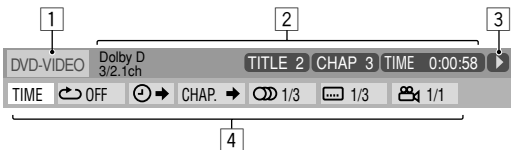

DVD-VR

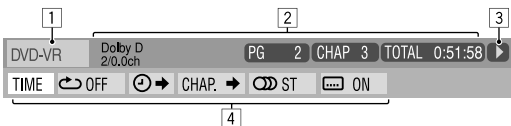

SVCD

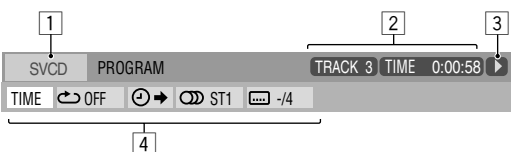

VCD

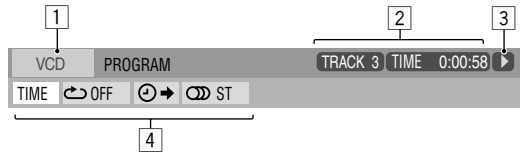

CD

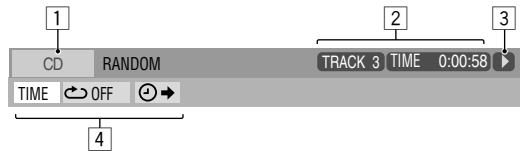

MPEG-1/MPEG-2/DivX files on a disc



MPEG-1/MPEG-2/DivX files in a USB mass storage class device



1 Disc/source type

2 Playback information

Dolby D	Audio format
3/2.1ch, 2/0.0 ch	Channel number
PROGRAM, RANDOM	Current play mode
TITLE 2	Current title
CHAP 3	Current chapter
TRACK 14	Current track
PG 2	Current program
PL 2	Current Play List
TIME 0:00:58	Time indications

3 Operation modes

	Playback
	Forward/Reverse search
	Forward/Reverse slow-motion
	Pause
	Stop

4 Function icons (on the pull-down menu)

	Select to change the time indication.
	Select to repeat playback.
	Select for time search.
	Select for chapter search.
	Select to change the audio language or channel (see also page 18).
	Select to change subtitle language (see also page 19).
	Select to change the view angle (see also page 19).

To operate using the On-screen Bar

Ex.: Selecting a subtitle (French) for DVD Video

While “DVD/CD” is selected as the source...

1 Display the entire on-screen bar.

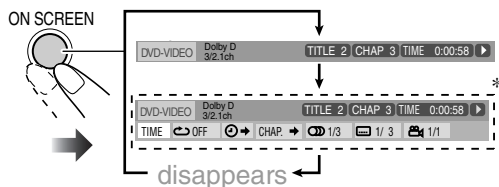

* This does not appear for MPEG-1/MPEG-2/DivX files.

2 Select (highlight) the item you want.

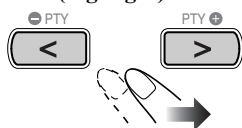

3 Display the pop-up window.



4 Select the desired option in the pop-up window.

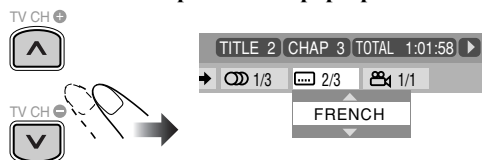

5 Finish the setting.

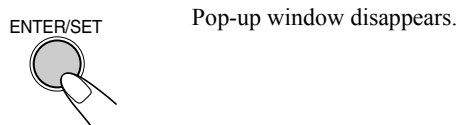

To remove the on-screen bar



To change the time information

You can change the time information on the on-screen bar and the display window on the main unit.

1 While playing, display the entire on-screen bar.



2 Make sure [TIME] is selected (highlighted).

3 Change the time indication.

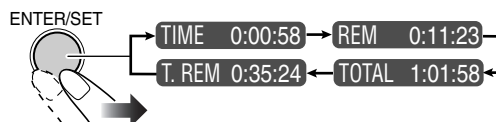

TIME	Elapsed playing time of the current chapter/track (not applicable for DVD-VR).
REM	Remaining time of the current chapter/track (not applicable for DVD-VR).
TOTAL	Elapsed disc time.
T. REM	Remaining time of title (DVD Video)/program (DVD VR)/disc (SVCD/VCD).

To remove the on-screen bar

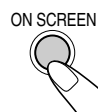

Repeat Play

• See also page 22.

1 While playing (without PBC for SVCD/VCD), display the entire on-screen bar.

• Repeat mode can also be selected before starting playback (not applicable for DVD Video/DVD-VR).

2 Select [OFF].

3 Display the pop-up window.

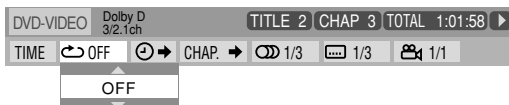

4 Select the repeat mode you want.

A-B	Repeats a desired portion (see below).
TITLE*	Repeats the current title.
ALL	Repeats the disc (not applicable for DVD) or programmed track.
CHAPTER**	Repeats the current chapter.
TRACK**	Repeats the current track.
OFF	Cancels Repeat Play.

* While playing a DVD-VR, “PG” appears, and while playing a Play List, “PL” appears.

** During Program Play and Random Play, “STEP” appears.

5 Finish the setting.

ENTER/SET



A-B Repeat

• See also page 23.

1 While playing, display the entire on-screen bar.

2 Select OFF.

3 Display the pop-up window.



4 Select “A-B.”

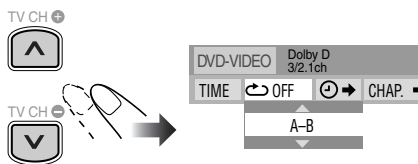

5 Select the start point (A).

ENTER/SET



6 Select the end point (B).

ENTER/SET



A-B Repeat starts. The selected portion plays repeatedly.

• Before pressing ENTER/SET, you can search for the end point using the button.

To cancel A-B Repeat, repeat steps 1 to 3, and select “OFF” in step 4.

Time Search

You can move to a particular point by specifying the elapsed playing time from the beginning.

• This function is not available during Program Play and Random Play.

1 While playing (without PBC for SVCD/VCD), display the entire on-screen bar.

• Time Search can also be used before starting playback (not applicable for DVD Video/DVD-VR).

2 Select .

3 Display the pop-up window.



4 Enter the time.

You can specify the time in hours/minutes/seconds.

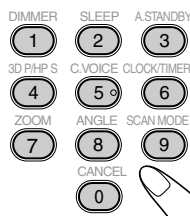

Examples:

To move to a point of 1 (hours): 02 (minutes): 00 (seconds), press 1, 0, 2, 0, then 0.

To move to a point of 54 (minutes): 00 (seconds), press 0, 5, 4, 0, then 0.

• It is always required to enter the hour digit (even “0” hours), but it is not required to enter the final zeros (the last two digits in the examples above).

• To correct a mis-entry, press < to erase the last entry.

5 Confirm your entry.

ENTER/SET



The System starts playing the disc from the selected playing time.

Chapter Search

For DVD Video/DVD-VR: You can search for the chapter number to play.

- This function is not available during Program Play and Random Play.

1 While playing, display the entire on-screen bar.

2 Select **[CHAP. →]**.

3 Display the pop-up window.



4 Enter the desired chapter number.

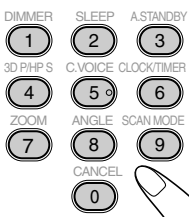

Examples:

- To select chapter 5, press 5.
- To select chapter 10, press 1, then 0.
- To select chapter 15, press 1, then 5.
- To select chapter 30, press 3, then 0.

- To correct a mis-entry, press the number buttons until the desired number is shown in the pop-up window.

5 Confirm your entry.

ENTER/SET



The System starts playing the selected chapter.



Operations on the Control Screen

You can search for and play the desired items through the control screen for DVD-VR and MP3/WMA/WAV/JPEG/MPEG-1/MPEG-2/DivX files.

Control screen for DVD-VR

The control screen is superimposed onto the TV screen when you call up Original Program (PG) or Play List (PL).

To select playback type

To display the Original Program:	To display the Play List:
<p>TOP MENU/PG</p> 	<p>MENU/PL</p> 
<p>To remove the list, press the same button again.</p>	

Ex.: When Original Program is selected.

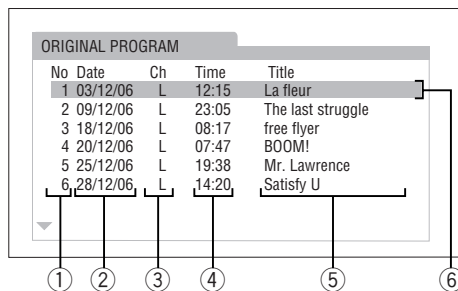

Ex.: When Play List is selected.

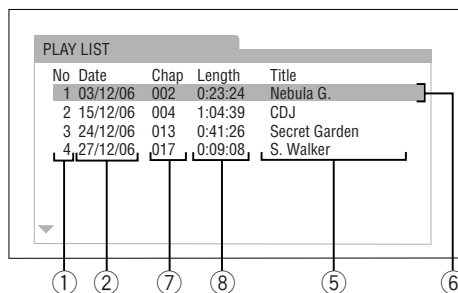

- 1 Listed number
- 2 Recording/creating date
- 3 Recording channels
- 4 Recording time
- 5 Title
- 6 Highlight bar (current selection)
- 7 Chapters included
- 8 Playback time

To select an item in the list and start playback

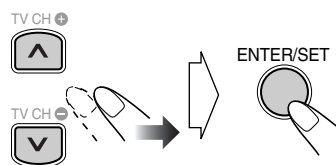

- If you move the highlight bar while playing back, the selected item starts playback automatically.

Control screen for MP3/WMA/WAV/JPEG/MPEG-1/MPEG-2/DivX files

The control screen automatically appears on the TV screen when the System detects MP3/WMA/WAV/JPEG/MPEG-1/MPEG-2/DivX files on the loaded disc or connected USB mass storage class device.

- For still/moving picture, it appears when playback is stopped.

Ex.: While playing an MP3 file on a disc.

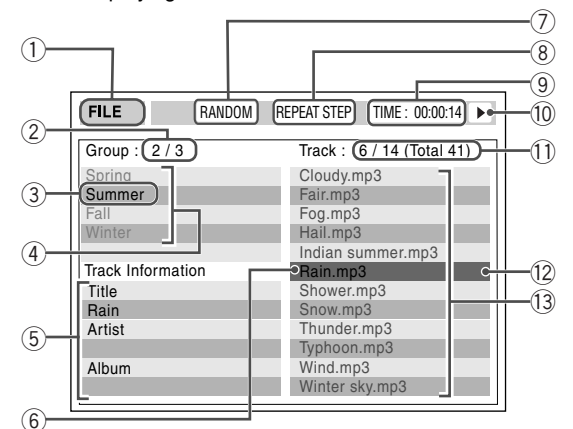

- ① Current source
FILE: Current source is "DVD/CD."
USB: Current source is "USB MEM."
- ② Current group number/total group number
- ③ Current group
- ④ Group list
- ⑤ File information (only for MP3/WMA/WAV files)
- ⑥ Current file
- ⑦ Random Play/Program Play setting (not applicable for the files in the USB mass storage class device)
- ⑧ Repeat Play setting
- ⑨ Elapsed playing time of the current file (not applicable for JPEG files)
- ⑩ Operation mode icon
- ⑪ Current file number/total number of files in the current group (total number of files on the loaded disc/USB mass storage class device)
- ⑫ Highlight bar (current selection)
- ⑬ File list

- If different types of playable files (audio/still picture/moving picture) are recorded on a disc or USB mass storage class device, select a file type to play (see "FILE TYPE" in "PICTURE" menu on page 31).

To move the highlight bar between group list and file list

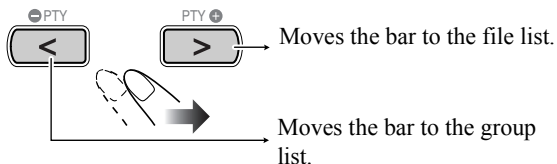

To select an item in the list

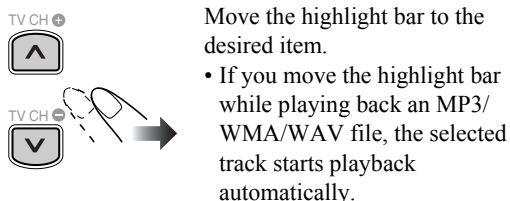

Move the highlight bar to the desired item.

- If you move the highlight bar while playing back an MP3/WMA/WAV file, the selected track starts playback automatically.

To start playback

For JPEG:	
	The selected file (still picture) is displayed until you change it.
<p>Disc</p> <p>USB mass storage class device</p>	<p>Press one of the buttons depending on the current source.</p> <p>Slide-show playback starts. Each file (still picture) is shown on the screen for about 3 seconds, then changes one after another.</p> <ul style="list-style-type: none"> • To cancel slide-show and display the current still picture, press II.
For the other files:	
	<p>Playback starts with the selected track.</p> <ul style="list-style-type: none"> • Pressing DVD/CD ▶ or USB MEMORY ▶ also starts playback.

- Once you start to play back a picture, the control screen disappears. To show the control screen, press TOP MENU/PG or MENU/PL.

Daily Timer Operations

Remote control

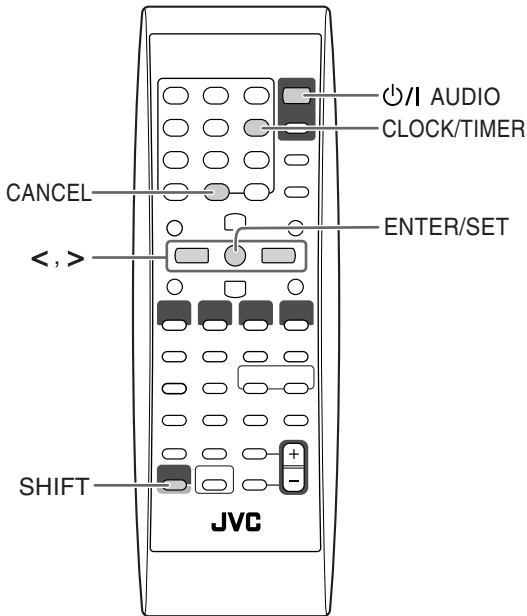

Setting the Daily Timer



Using Daily Timer, you can wake up with your favorite music.

You can store three Daily Timer settings; however, you can activate only one of the timers at any one time.

- To exit the timer settings, press CLOCK/TIMER (while holding SHIFT) as required.
- To correct a mis-entry during process, press CANCEL (while holding SHIFT). You can go back to the previous step.

Initial Daily Timer settings when shipped from the factory:

- DAILY 1: ON Time (6:00)/OFF Time (8:00)/Source (TUNER FM 1)/Volume level (--)
- DAILY 2: ON Time (7:00)/OFF Time (9:00)/Source (TUNER FM 1)/Volume level (--)
- DAILY 3: ON Time (10:00)/OFF Time (12:00)/Source (TUNER FM 1)/Volume level (--)

- 1** Select one of the timer setting modes you want to set—DAILY 1 ON time, DAILY 2 ON time, or DAILY 3 ON time.

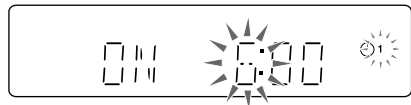
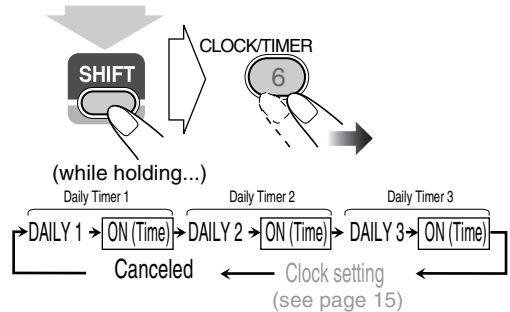

Ex. When Daily Timer 1 setting mode is selected

- When the clock has not been set, pressing CLOCK/TIMER (while holding SHIFT) makes the System enter the clock setting mode (see page 15).

- 2** Set the timer as you like.

Repeat the procedure for the following settings until finished.

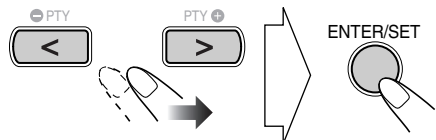

- ① Set the hour then the minute for on-time.
- ② Set the hour then the minute for off-time.
- ③ Select the playback source—"TUNER FM," "TUNER AM," "DISC," "LINE," "USB MEM," or "TV SOUND."



- ④ For "TUNER FM" and "TUNER AM": Select a preset channel.
For "DISC": Select the title/group number, then the chapter/track/file number.
For "USB MEM": Select the group number, then the track/file number.
- ⑤ Select the volume level.
 - You can adjust the volume level ("1" to "40" and "VOL --").
 - If you select "VOL --," the volume is set to the same level as when the System was last turned off.

Once settings are completed, the timer setting information appears in sequence.

- 3 Turn off the System (on standby), if you have set the timer with the System turned on.



How Daily Timer works

Once the Daily Timer has been set, the timer indicator (☉) and timer number indicator (1/2/3) are lit on the display. Daily Timer is activated at the same time everyday until the timer is turned off manually (see the next column) or another timer is activated.

When the on-time comes

The System turns on, tunes in to the specified station or starts playing from the specified source, and gradually increases the volume level to the preset level after for 30 seconds.

- While Daily Timer is working, the timer indicator (☉) flashes on the display.

When the off-time comes

The System stops playback, and turns off (on standby) automatically.

- The timer setting remains in memory until you change it.

To turn on or off the Daily Timer

Since Daily Timer is activated at the same time everyday, you may need to cancel it on some particular days.

To cancel the Daily Timer

- 1 Select the Timer (DAILY 1, DAILY 2, or DAILY 3) you want to cancel.

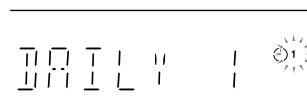
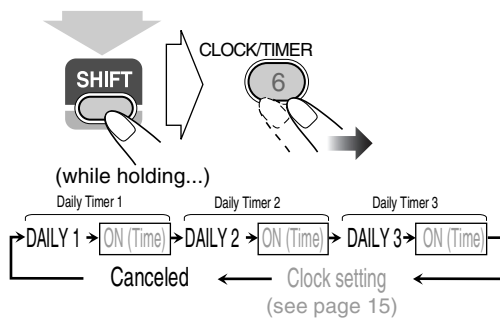

Ex. To cancel Daily Timer 1

- 2 Turn off the selected Timer.

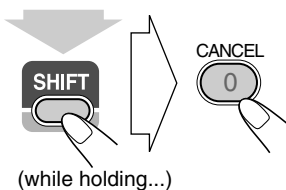

To turn on the Daily Timer

- 1 Select the Timer (DAILY 1, DAILY 2, or DAILY 3) you want to activate.

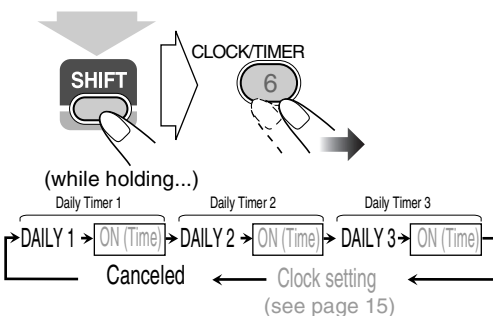

- 2 Activate the selected Timer.



Ex. When Daily Timer 1 (DAILY 1) is activated

- 3 Wait until the indication disappears.

Setup Menu Operations INFO

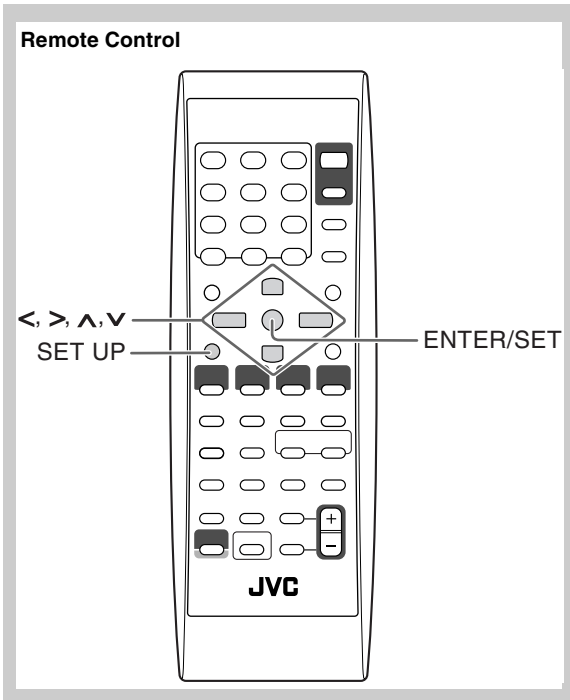

Initial settings Remote ONLY

You can change the settings of the System.

- The Setup Menu can be used only when “DVD/CD” or “USB MEM” is selected as the source.

1 Press SET UP while playback is stopped.

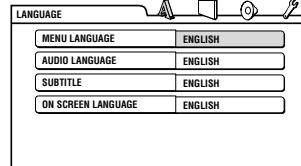

2 Press > (or <) to select the menu.

3 Press v (or ^) to move to select the item.

4 Press ENTER/SET.

5 Press v (or ^) to select the options, then press ENTER/SET.

To remove a preference display
Press SET UP.

LANGUAGE menu

Item	Contents
MENU LANGUAGE	You can select the initial menu language for DivX files/DVD Video. (See page 37.)
AUDIO LANGUAGE	You can select the initial audio language for DivX files/DVD Video. (See page 37.)
SUBTITLE	You can select the initial subtitle language for DivX files/DVD Video. (See page 37.)
ON SCREEN LANGUAGE	You can select “ENGLISH,” “FRENCH,” “GERMAN,” “CZECH,” “SLOVAK,” “POLISH” or “HUNGARIAN” as the on-screen language.

PICTURE menu

Item	Contents
MONITOR TYPE 	You can select the monitor type to match your TV when you play back picture recorded for wide-screen televisions. 16:9 NORMAL (Wide-screen television): Select this when the aspect ratio of your wide-screen TV is fixed to 16:9. 16:9 AUTO (Wide-screen television): Select this when your TV is an ordinary wide-screen TV. 4:3 LB (Letter Box conversion): For a conventional (4:3) TV. Displays a wide-screen picture to fit the width of the TV screen keeping the aspect ratio. 4:3 PS (Pan Scan conversion): For a conventional (4:3) TV. The picture is zoomed in to fill the screen vertically and the left and right sides of the picture are cut off.
PICTURE SOURCE	You can obtain optimal picture quality by selecting the source type of the video source. AUTO: Normally, select this option. The System recognizes the picture type (film or video source) of the current picture according to its information. FILM: For a film source picture. VIDEO: For a video source picture.
SCREEN SAVER	You can set the screen saver function (ON or OFF). If no operation is done for about 5 minutes, the TV screen dims.
FILE TYPE	You can select the file type to play. AUDIO: To play MP3/WMA/WAV files. STILL PICTURE: To play JPEG files. VIDEO: To play MPEG-1/MPEG-2/DivX files.



AUDIO menu

Item	Contents
DIGITAL AUDIO OUTPUT	Set this item correctly when using the OPTICAL DIGITAL OUT terminal on the rear. PCM ONLY: When connecting to audio equipment which is compatible with only linear PCM signals. DOLBY DIGITAL/PCM: When connecting to a Dolby Digital decoder or an amplifier with a built-in Dolby Digital decoder. STREAM/PCM: When connecting to a DTS decoder or an amplifier with a built-in DTS decoder.
DOWN MIX	This setting is effective for digital audio output if “DIGITAL AUDIO OUTPUT” is set to “PCM ONLY.” DOLBY SURROUND: Select this when connecting to a surround decoder. STEREO: Select this when connecting to a stereo receiver, MD player, etc.
D. RANGE COMPRESSION	You can enjoy powerful audio even at a low volume level while playing Dolby Digital software. AUTO: You can enjoy powerful playback sound with full dynamic range. ON: Select this when you want to fully apply the compression effect to make the sound at lower volume clear (useful at midnight).



OTHERS menu

Item	Contents
RESUME	You can select Resume. ON: The System resumes playback from the position where playback has been stopped. OFF: Resume is deactivated.
ON SCREEN GUIDE	Activate (ON) or deactivate (OFF) the on-screen guide.
DivX REGISTRATION	The System has its own Registration Code. If necessary, you can confirm it. Once you have played back a DivX file in which the Registration Code is recorded, the System's Registration Code is overwritten for copyright protection.

Additional Information

Learning More about This System ● ● ●

Connections (see pages 3 to 5)

- Make sure the antenna conductors do not touch any other terminals, connecting cords or the power cord. Also, keep the antennas away from metallic parts of the System, connecting cords, and the power cord. These could cause poor reception.
- Use only speakers with the same speaker impedance as indicated by the speaker terminals on the rear of the System.
- The speakers are magnetically shielded to avoid color distortions on TVs. However, if not installed properly, it may cause color distortions. So, pay attention to the following when installing the speakers.
 - When placing the speakers near a TV set, turn off the TV's main power switch or unplug it before installing the speakers.
Then wait at least 30 minutes before turning on the TV's main power switch again.
 - Some TVs may still be affected even though you have followed the above instructions. If this happens, move the speakers away from the TV.

Daily Operations—Playback (see pages 7 to 11)

Listening to the Radio:

- If you store a new station into an occupied preset number, the previously stored station in that number will be erased.
- When you unplug the power cord or if a power failure occurs, the preset stations will be erased in a few days. If this happens, preset the stations again.

Playing Back a Disc/USB mass storage class device:

- When you change the source to “DVD/CD” or “USB MEM,” it may take a while to activate the source.
- While the System is reading a disc, the source may not change to “USB MEM” properly. In this case, press ■, then reselect “USB MEM” as the source.
- On some discs, the actual operations may be different from what is explained in this manual due to the programming and disc structure; such differences are not a malfunction of this System.
- The System recognizes up to 150 tracks (files) per group, and 99 groups per disc/USB mass storage class device. The total number of tracks (files) that the System can detect is 4000.
 - If there are any unplayable files in a folder, those files are also counted in the total file number.
 - Playable files which do not belong to any groups are handled as GROUP 1.

- For playback of files in the USB mass storage class device...
 - When connecting a USB mass storage class device, refer also to its manual.
 - Connect one USB mass storage class device to the System at a time. Do not use a USB hub.
 - You cannot charge any USB mass storage class device through the USB MEMORY  terminal.
 - While playing back a file in a USB mass storage class device, do not disconnect the device. It may cause malfunction on both the System and the device.
 - JVC bears no responsibility for any loss of data in the USB mass storage class device while using this System.
 - This System is compatible with USB 2.0 Full Speed.
 - You can play back the following types of files in a USB mass storage class device (maximum data transfer rate: 2 Mbps):
 - Music: MP3, WMA, WAV
 - Picture: JPEG
 - Movie: MPEG-1, MPEG-2, DivX (maximum frame rate of 30 fps for progressive)
 - This System may not play back some files even though their formats are listed above.
 - You cannot play back a file larger than 2 Gigabytes.
 - When playing a file of a large transfer rate, frames or sounds may be dropped during playback.
 - This System cannot recognize a USB mass storage class device whose rating is other than 5 V and does not exceed 500 mA.
 - This System may not play back some USB mass storage class devices and does not support DRM (Digital Rights Management).
 - It will take some time to start up a digital audio player whose contents are larger than 1 Gigabyte.
- For DVD-VR playback...
 - This System can play only a disc of UDF-Bridge format.
 - For details about DVD-VR format and Play List, refer to the manual of the recording equipment.
- For MP3/WMA/WAV playback...
 - MP3/WMA/WAV discs require a longer readout time than regular CDs. (It depends on the complexity of the group/file configuration.)
 - Some MP3/WMA/WAV files cannot be played back and will be skipped. This results from their recording processes and conditions.
 - This System can play only a disc of ISO 9660 Level 1 or Level 2.
 - This System can play back MP3/WMA/WAV files with the extension code <mp3>, <.wma>, or <.wav> (regardless of the letter case—upper/lower).
 - It is recommended that you make each MP3/WMA/WAV files as following conditions:
 - For MP3/WMA files: At a sample rate of 44.1 kHz and at a data transfer rate of 128 kbps. This System cannot play back files made at a bit rate of less than 64 kbps.
 - For WAV files: At a sample rate of 44.1 kHz and at a quantization rate of 16 bit Linear PCM.

- For JPEG files playback...
 - It is recommended that you record a file at 640 x 480 resolution. (If a file has been recorded at a resolution of more than 640 x 480, it will take a long time to be shown.)
 - This System can play only baseline JPEG files*. Progressive JPEG files* or lossless JPEG files* cannot be played.
 - * Baseline JPEG format: Used for digital cameras, web, etc.
 - Progressive JPEG format: Used for web.
 - Lossless JPEG format: An old type and rarely used now.
 - This System can play back JPEG files with the extension code <.jpg> or <.jpeg> (regardless of the letter case—upper/lower).
 - This System may not play back JPEG files properly if they are recorded from a device other than a digital camera.
- For MPEG-1/MPEG-2 playback...
 - This System can play back MPEG-1/MPEG-2 files with the extension code <.mpg> or <.mpeg> (regardless of the letter case—upper/lower).
 - The stream format should conform to MPEG system/program stream.
 - 720 x 576 pixels (25 fps)/720 x 480 pixels (30 fps) is recommended for the highest resolution.
 - This System also supports the resolutions of 352 x 576/480 x 576/352 x 288 pixels (25 fps) and 352 x 480/480 x 480/352 x 240 pixels (30 fps).
 - The file format should be MP@ML (Main Profile at Main Level)/SP@ML (Simple profile at Main Level)/MP@LL (Main Profile at Low Level).
 - Audio streams should conform to MPEG1 Audio Layer-2 or MPEG2 Audio Layer-2.
- For DivX playback...
 - This System can play only a disc of UDF-Bridge format. “Multi-border” is not supported.
 - The System supports all versions of DivX® video (including DivX® 6).
 - The System supports DivX files whose resolution is 720 x 480 pixels or less (30 fps), and 720 x 576 pixels or less (25 fps).
 - Audio stream should conform to Dolby Digital, MPEG1 Audio Layer-2 or MPEG Audio Layer-3 (MP3).
 - This System can play back DivX files with the extension code <.divx> <.div> <.avi> (regardless of the letter case—upper/lower).
 - The System does not support GMC (Global Motion Compression).
 - The file encoded in the interlaced scanning mode may not be played back correctly.

Playing Back a Digital Audio Player:

- When QP Link fails due to a weak sound signal from the LINE IN jack, Auto Standby may turn the System off even if you can hear the sound from the speakers. In such cases, adjust the volume level of the component louder so that the System can detect the sound signal properly.

- Changing from “LINE” to another source while QP Link works will deactivate QP Link temporarily. In this case, the following reactivates QP Link:
 - Pressing QP LINK on the remote control twice.
 - Unplugging the component from the LINE IN jack, then plugging back it in again.
- If you press **⏻/I** (Standby/on) to turn the System off or if preset Timer turns the System off while QP Link works, the System will deactivate QP Link temporarily. In such cases, the following reactivates QP Link:
 - When the sound signal from the LINE IN jack stops or is too weak for about 30 seconds after the System is turned off.
 - When you turn on the power again.
- QP Link may start working when you just connect the component to the LINE IN jack or disconnect it. This is not a malfunction.
- QP Link does not work when the display is turned off (see page 7).

Daily Operations—Sound & Other Adjustments (see pages 12 to 15)

Adjusting the Sound:

- This function also affects the sound through the headphones.

Changing the Scanning Mode:

- You cannot change the scanning mode to progressive in the following cases:
 - When your TV does not support the progressive video input.
 - When you have not connected your TV to the system using a component video cord.

Setting the Clock:

- “0:00” will flash on the display until you set the clock.
- The clock may gain or lose 1 to 2 minutes per month. If this happens, reset the clock.

Advanced Radio Operations (see pages 16 and 17)

- If you want to know more about Radio Data System, visit <<http://www.rds.org.uk>>.
- If the System takes time to display the Radio Data System information—PS, PTY, RT signals, “WAIT PS,” “WAIT PTY,” or “WAIT RT” will appear while searching.

Unique Video Disc/File Operations (see pages 18 to 20)

Selecting the Audio Track:

- On some discs/files, you cannot change audio language during playback.

Special Effect Playback:

- During slow-motion playback, no sound will be emitted.
- While zoomed in, the picture may look coarse.

Advanced Playback Operations (see pages 21 to 23)

Programming the Playing Order—Program Play:

- While programming steps...
Your entry will be ignored if you have tried to program an item number that does not exist (for example, selecting track 14 on a disc that only has 12 tracks).

Playing Repeatedly:

- A-B Repeat is available only within the same title/program/track.

On-Screen Operations (see pages 24 to 28)

On-screen Bar Operations:

- For DVD-VR, “PG” or “PL” appears instead of “TITLE” on the on-screen bar.

Daily Timer Operations (see pages 29 and 30)

Setting the Daily Timer:

- If you do not specify the preset station or track number correctly while setting a timer, the currently selected station or the first track will be played when the timer is activated.
- When you unplug the power cord or if a power failure occurs, the timer will be canceled. You need to set the clock first, then the timer again.
- If you set DVD Video as the source, Daily Timer will not work correctly.
- If you set the Sleep Timer after Daily Timer starts playing the selected source, Daily Timer is canceled.

Setup Menu Operations (see pages 31 and 32)

General:

- If the upper and lower parts of the menu are cut off, adjust the picture size control of the TV.

LANGUAGE menu:

- When the language you have selected for “MENU LANGUAGE,” “AUDIO LANGUAGE,” or “SUBTITLE” is not recorded, the original language is used as the initial language.

PICTURE menu—MONITOR TYPE:

- Even if “4:3 PS” is selected, the screen size may become 4:3 letter box while playing a disc/file. This depends on how the discs are recorded.
- When you select “16:9” for a picture whose aspect ratio is 4:3, the picture changes slightly due to the process of converting the picture width.

OTHERS menu—ON SCREEN GUIDE:

- The setup menu and on-screen bar will be displayed (and recorded) even if this function is set to “OFF.”
Subtitles and the information for zoom-in always appear on the display regardless of this setting.

Maintenance

To get the best performance of the System, keep your discs and mechanism clean.

Handling discs

- Remove the disc from its case by holding it at the edge while pressing the center hole lightly.
- Do not touch the shiny surface of the disc, or bend the disc.
- Put the disc back in its case after use to prevent warping.
- Be careful not to scratch the surface of the disc when placing it back in its case.
- Avoid exposure to direct sunlight, extreme temperature, and moisture.

To clean the disc:

Wipe the disc with a soft cloth in a straight line from center to edge.

Cleaning the System

- Stains should be wiped off with a soft cloth. If the System is heavily stained, wipe it with a cloth soaked in water-diluted neutral detergent and wrung well, then wipe clean with a dry cloth.
- Since the System may deteriorate in quality, become damaged or get its paint peeled off, be careful about the following:
 - DO NOT wipe it with a hard cloth.
 - DO NOT wipe it forcefully.
 - DO NOT wipe it with thinner or benzene.
 - DO NOT apply any volatile substance such as insecticides to it.
 - DO NOT allow any rubber or plastic to remain in contact for a long time.

To remove the speaker grilles:

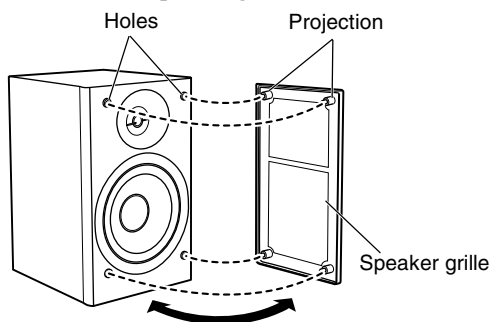

Troubleshooting

General:

Adjustments or settings are suddenly canceled before you finish.

⇒ There is a time limit. Repeat procedure again.

Operations are disabled.

⇒ The built-in microprocessor may malfunction due to external electrical interference. Unplug the power cord and then plug it back in.

Unable to operate the System from the remote control.

⇒ The path between the remote control and the remote sensor on the System is blocked.

⇒ The batteries are exhausted.

No sound is heard.

⇒ Speaker connections are incorrect or loose.

⇒ Headphones are connected.

No picture appears on the TV screen.

⇒ The video cord connections are incorrect or loose.

No picture is displayed on the TV screen, the picture is blurred, or the picture is divided into two parts.

⇒ The System is connected to a TV which does not support progressive video input.

⇒ Incorrect scanning mode is selected (see page 14).

⇒ When you unplug the power cord and plug it back again, the scanning mode may change back to the initial setting (“RGB”) (see page 14).

The left and right edges of the picture are missing on the screen.

⇒ Select “4:3 LB” for “MONITOR TYPE” (see page 31).

Radio Operations:

Hard to hear broadcasts because of noise.

⇒ Antenna connections are incorrect or loose.

⇒ The AM loop antenna is too close to the System.

⇒ The FM antenna is not properly extended and positioned.

Disc/USB mass storage class device Playback Operations:

The disc does not play.

⇒ You have inserted a disc whose Region Code is not “2.” (“RG ERROR” appears on the display.)

⇒ The disc is placed upside down. Place the disc with the label side facing up.

ID3 Tag on an MP3 file cannot be shown.

⇒ There are two types of ID3 Tag—Version 1 and Version 2. This System can only show ID3 Tag Version 1.

Groups and tracks are not played back as you expect.

⇒ The playing order is determined when the groups and tracks were recorded. It depends on the writing application.

MP3, WMA, WAV, JPEG, MPEG-1, MPEG-2 or DivX files are not played back.

⇒ The disc or the USB mass storage class device may contain different types of files (ex. MP3/WMA/WAV/JPEG). In this case, you can only play back the files selected by the “FILE TYPE” setting (see page 31).

⇒ You have changed the “FILE TYPE” setting after the System read the disc or the USB mass storage class device. In this case, reload the disc or disconnect the USB mass storage class device and connect it again.

The disc sound is discontinuous.

⇒ The disc is scratched or dirty.

No subtitle appears on the display though you have selected the initial subtitle language.

⇒ Some DVDs/DivX files are programmed not to display any subtitle initially. If this happens, press SUBTITLE after starting play back (see page 19).

Audio language is different from the one you have selected as the initial audio language.

⇒ Some DVDs/DivX files are programmed to always use the original language initially. If this happens, press AUDIO/MPX after starting playback (see page 18).

The disc tray does not open or close.

⇒ The power cord is not plugged in.

⇒ Child Lock is in use. “LOCKED” appears in the display window (see page 23).

QP Link Operations:

The System automatically turns on even if the Timer turns the System to standby or if you turn the System to standby while playback is going on the digital audio player.

⇒ In this case, deactivate QP Link or stop playback on the digital audio player connected to the LINE IN jack.

Timer Operations:

Daily Timer does not work.

⇒ The System has been turned on when the on-time came. Timer starts working only when the System is turned off.

Daily Timer does not start playback.

⇒ The loaded disc is a DVD Video. Change the disc.

Language Code List

AA	Afar
AB	Abkhazian
AF	Afrikaans
AM	Ameharic
AR	Arabic
AS	Assamese
AY	Aymara
AZ	Azerbaijani
BA	Bashkir
BE	Byelorussian
BG	Bulgarian
BH	Bihari
BI	Bislama
BN	Bengali, Bangla
BO	Tibetan
BR	Breton
CA	Catalan
CO	Corsican
CY	Welsh
DA	Danish
DZ	Bhutani
EL	Greek
EO	Esperanto
ET	Estonian
EU	Basque
FA	Persian
FI	Finnish
FJ	Fiji
FO	Faroese
FY	Frisian
GA	Irish
GD	Scots Gaelic
GL	Galician
GN	Guarani
GU	Gujarati
HA	Hausa
HI	Hindi
HR	Croatian
HY	Armenian
IA	Interlingua
IE	Interlingue
IK	Inupiak
IN	Indonesian
IS	Icelandic
IW	Hebrew
JI	Yiddish
JW	Javanese
KA	Georgian

KK	Kazakh
KL	Greenlandic
KM	Cambodian
KN	Kannada
KO	Korean (KOR)
KS	Kashmiri
KU	Kurdish
KY	Kirghiz
LA	Latin
LN	Lingala
LO	Laothian
LT	Lithuanian
LV	Latvian, Lettish
MG	Malagasy
MI	Maori
MK	Macedonian
ML	Malayalam
MN	Mongolian
MO	Moldavian
MR	Marathi
MS	Malay (MAY)
MT	Maltese
MY	Burmese
NA	Nauru
NE	Nepali
NL	Dutch
NO	Norwegian
OC	Occitan
OM	(Afan) Oromo
OR	Oriya
PA	Panjabi
PS	Pashto, Pushto
PT	Portuguese
QU	Quechua
RM	Rhaeto-Romance
RN	Kirundi
RO	Rumanian
RW	Kinyarwanda
SA	Sanskrit
SD	Sindhi
SG	Sangho
SH	Serbo-Croatian
SI	Singhalese
SL	Slovenian
SM	Samoan
SN	Shona
SO	Somali
SQ	Albanian

SR	Serbian
SS	Siswati
ST	Sesotho
SU	Sundanese
SV	Swedish
SW	Swahili
TA	Tamil
TE	Telugu
TG	Tajik
TH	Thai
TI	Tigrinya
TK	Turkmen
TL	Tagalog
TN	Setswana
TO	Tonga
TR	Turkish
TS	Tsonga
TT	Tatar
TW	Twi
UK	Ukrainian
UR	Urdu
UZ	Uzbek
VI	Vietnamese
VO	Volapuk
WO	Wolof
XH	Xhosa
YO	Yoruba
ZU	Zulu

OPTICAL DIGITAL OUT Signals

DIGITAL AUDIO OUTPUT Playback disc/file	Output Signals		
	STREAM/PCM	DOLBY DIGITAL/PCM	PCM ONLY
DVD Video			
with 48 kHz, 16/20/24 bit Linear PCM	48 kHz, 16 bit Linear PCM*		
with 96 kHz, Linear PCM	48 kHz, 16 bit Linear PCM		
with Dolby Digital	Dolby Digital bitstream	48 kHz, 16 bit Linear PCM	
with DTS	DTS bitstream	48 kHz, 16 bit Linear PCM	
DVD-R/-RW in DVD-VR format			
with 48 kHz, 16/20/24 bit Linear PCM	48 kHz, 16 bit Linear PCM*		
with Dolby Digital	Dolby Digital bitstream	48 kHz, 16 bit Linear PCM	
SVCD/VCD/CD	44.1 kHz, 16 bit Linear PCM/48 kHz, 16 bit Linear PCM		
CD with DTS	DTS bitstream	44.1 kHz, 16 bit Linear PCM	
MP3/WMA/WAV/MPEG-1/MPEG-2	32/44.1/48 kHz, 16 bit Linear PCM		
DivX disc/file			
with MP2, MP3	32/44.1/48 kHz, 16 bit Linear PCM		
with Dolby Digital	Dolby Digital bitstream	32/44.1/48 kHz, 16 bit Linear PCM	

* While playing some DVDs, digital signals may be emitted at 20 bits or 24 bits (at their original bit rate) through the OPTICAL DIGITAL OUT terminal if the discs are not copy-protected.

Operating JVC's TVs Using the Remote Control

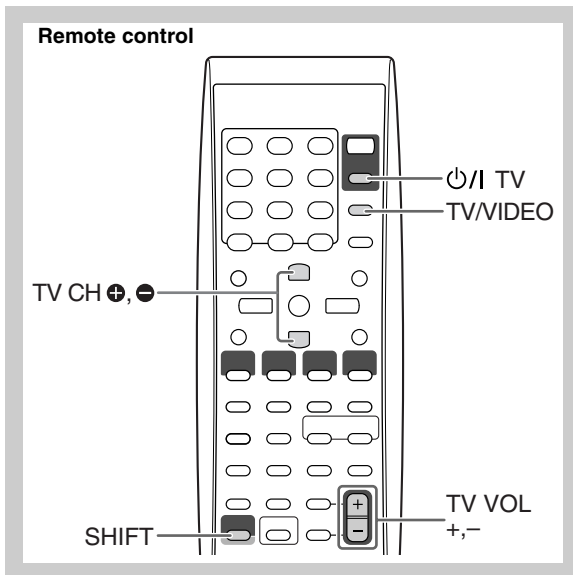

You can use the remote control to operate JVC's TVs.

⏻/TV	Turn on/off TV.
TV/VIDEO	Change the input mode.

While holding SHIFT, press...

TV VOL +, -	Adjust the volume.
TV CH +, -	Change the channel.

Specifications

Amplifier section—CA-UXG49/CA-UXG48

Output Power:	40 W (20 W + 20 W) at 6 Ω (10% THD)
Audio Input	LINE IN: 500 mV/50 kΩ (at “IN_LVL1”) 250 mV/50 kΩ (at “IN_LVL2”) 125 mV/50 kΩ (at “IN_LVL3”)
Audio output	LINE OUT: 1.0 Vrms (47 kΩ) (at “OUT_LVL1”) 2.0 Vrms (47 kΩ) (at “OUT_LVL2”)
Digital output	OPTICAL DIGITAL OUT: –21 dBm to –15 dBm (660 nm ±30 nm)
Digital input:	USB MEMORY
Video Out:	
Color system:	PAL (interlaced/progressive)
Composite video:	1 V(p-p)/75 Ω
S-VIDEO: Y (luminance)	1 V(p-p)/75 Ω
C (chrominance, burst)	0.3 V(p-p)/75 Ω
RGB:	0.7 V(p-p)/75 Ω
COMPONENT: (Y)	1 V(p-p)/75 Ω
(P _B /P _R)	0.7 V(p-p)/75 Ω
Speaker impedance:	6 Ω – 16 Ω

Tuner section

FM tuning range:	87.50 MHz – 108.00 MHz
AM (MW) tuning range:	522 kHz – 1 629 kHz

Disc player section

Playable disc:	DVD Video/CD/VCD/SVCD/ CD-R/CD-RW (CD/SVCD/VCD/MP3/ WMA/WAV/JPEG/MPEG-1/MPEG-2/ DivX format) DVD-R/-RW (DVD-VR/DVD Video/MP3/ WMA/WAV/JPEG/MPEG-1/MPEG-2/ DivX format) +R/+RW (DVD Video/MP3/WMA/WAV/ JPEG/MPEG-1/MPEG-2/DivX format) DVD-ROM (MP3/WMA/WAV/JPEG/ MPEG-1/MPEG-2/DivX format)
Dynamic range:	80 dB
Horizontal resolution:	500 lines
Wow and flutter:	Immeasurable

USB section

Playable files:	MP3/WMA/WAV/JPEG/MPEG-1/ MPEG-2/DivX format
USB specification:	Compatible with USB 2.0 Full Speed
Compatible device:	Mass storage class
Compatible system:	FAT16, FAT32
Bus power supply:	500 mA/5 V

General

Power requirements:	AC 230 V ~ , 50 Hz
Power consumption:	26 W (at operation) 7 W (at standby) 1 W (at display-off mode)
Dimensions (approx.):	175 mm x 251 mm x 247 mm (W/H/D)
Mass (approx.):	2.6 kg

Speakers—SP-UXG49/SP-UXG48

Speaker units:	Tweeter: 1.5 cm dome x 1 Woofers: 10 cm cone x 1
Impedance:	6 Ω
Dimensions (approx.):	145 mm x 251 mm x 175 mm (W/H/D)
Mass (approx.):	1.7 kg each

Supplied Accessories

See page 3.

Design and specifications are subject to change without notice.

- Manufactured under license from Dolby Laboratories. “Dolby”, “Pro Logic”, and the double-D symbol are trademarks of Dolby Laboratories.
- “DTS” is a registered trademark of DTS, Inc. and “DTS2.0+Digital Out” is a trademark of DTS, Inc.
- “Official DivX[®] Ultra Certified product” “Plays all versions of DivX[®] video (including DivX[®] 6) with enhanced playback of DivX[®] media files and the DivX[®] Media Format” “DivX, DivX Ultra Certified, and associated logos are trademarks of DivX, Inc. and are used under licence.”
- Microsoft and Windows Media are either registered trademarks or trademarks of Microsoft Corporation in the United States and/or other countries.
- This product incorporates copyright protection technology that is protected by U.S. patents and other intellectual property rights. Use of this copyright protection technology must be authorized by Macrovision, and is intended for home and other limited viewing uses only unless otherwise authorized by Macrovision. Reverse engineering or disassembly is prohibited.
- “CONSUMERS SHOULD NOTE THAT NOT ALL HIGH DEFINITION TELEVISION SETS ARE FULLY COMPATIBLE WITH THIS PRODUCT AND MAY CAUSE ARTIFACTS TO BE DISPLAYED IN THE PICTURE. IN CASE OF 525 OR 625 PROGRESSIVE SCAN PICTURE PROBLEMS, IT IS RECOMMENDED THAT THE USER SWITCH THE CONNECTION TO THE ‘STANDARD DEFINITION’ OUTPUT. IF THERE ARE QUESTIONS REGARDING OUR TV SET COMPATIBILITY WITH THIS MODEL 525p AND 625p DVD PLAYER, PLEASE CONTACT OUR CUSTOMER SERVICE CENTER.”

Parts Index

Remote control

Button	Page
⓪/I AUDIO	25 7, 30
⓪/I TV	26 38
■	15 9, 10, 21, 22
▶▶, ◀◀	17 8, 10
▶▶, ◀◀	38 8, 10, 21, 22
II	16 9, 20 – 22, 28
△, ∇, >, <, ENTER/SET	11 8, 10, 14 – 16, 19 – 21, 25 – 31
⤵ (One-Touch Replay)	36 20
3D P/HPS	5 13
A.STANDBY	24 15
AHB PRO	20 12
ANGLE	17 19
AUDIO/MPX	19 18
AUDIO VOL +, -	41 7, 12
BASS/TREBLE	43 12
C.VOICE	4 13
CANCEL	9 15, 22, 29, 30
CLOCK/TIMER	27 15, 29, 30
DIMMER	3 7, 13
DISPLAY	30 15, 16
DVD/CD ▶	14 7, 9 – 11, 20 – 22, 28
DVD/LINE LEVEL	21 11, 13
FADE MUTING	42 12
FM/AM	34 7, 8, 11
FM/PLAY MODE	39 8, 21, 22
GROUP/TITLE	37 9
GROUP/TITLE SKIP	38 9
LINE/TV SOUND	35 7, 9, 11
MENU/PL	32 10, 27, 28
Number buttons	1 8, 10, 26, 27
ON SCREEN	33 25
PTY	11 16
PTY SEARCH	32 16
QP LINK	20 11
REPEAT	40 22
REPEAT A-B	40 23
RETURN	8 10
SCAN MODE	29 14
SET UP	12 31
SHIFT	22 7, 9, 10, 12 – 17, 19, 20, 22, 23, 29, 30, 38
SLEEP	2 15
SLOW	17 20
SOUND TURBO II	23 12
SUBTITLE	18 19
TA/News/Info	12 17
TOP MENU/PG	10 10, 27, 28
TV CH	11 38
TV/VIDEO	28 38
TV VOL +, -	41 38
USB MEMORY ▶	13 7, 9 – 11, 20, 28
VFP	31 14
ZOOM	6 20

Main unit

Button	Page
⓪/I & STANDBY lamp	(3) 7, 23
■	(6) 9, 23
▲	(16) 9
▶▶/UP, DOWN ◀◀	(7/15) 8, 10, 21
DIMMER	(2) 7, 13
Display	(1) 6
DVD/CD ▶/II	(5) 7, 9, 11, 20, 28
FM/AM	(3) 7, 8, 11
LINE IN/OUT	(17) 5
LINE/TV SOUND	(14) 7, 9, 11
PHONES	(9) 7
Remote sensor	(10) 5
SOUND TURBO II	(11) 12
USB MEMORY jack	(8) 5
USB MEMORY ▶/II	(4) 7, 9, 11, 20, 28
VOLUME +, -	(12) 12

Remote control

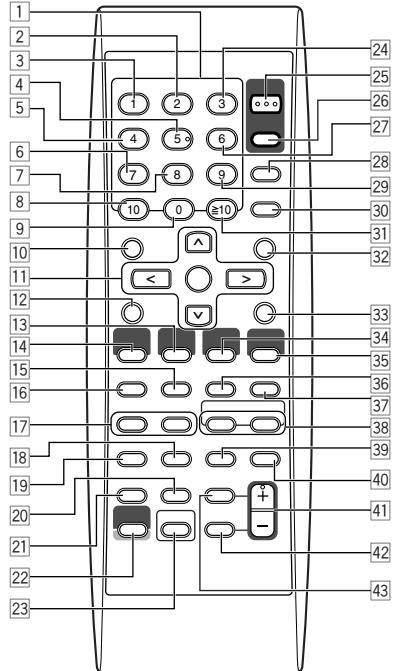

This remote control can also operate JVC's TVs (see page 38).

Main unit

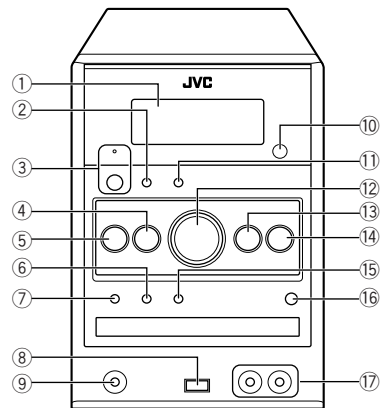

SAFETY INSTRUCTIONS

“SOME DOS AND DON'TS ON THE SAFE USE OF EQUIPMENT”

This equipment has been designed and manufactured to meet international safety standards but, like any electrical equipment, care must be taken if you are to obtain the best results and safety is to be assured.

Do read the operating instructions before you attempt to use the equipment.

Do ensure that all electrical connections (including the mains plug, extension leads and interconnections between pieces of equipment) are properly made and in accordance with the manufacturer's instructions. Switch off and withdraw the mains plug when making or changing connections.

Do consult your dealer if you are ever in doubt about the installation, operation or safety of your equipment.

Do be careful with glass panels or doors on equipment.

DON'T continue to operate the equipment if you are in any doubt about it working normally, or if it is damaged in any way—switch off, withdraw the mains plug and consult your dealer.

DON'T remove any fixed cover as this may expose dangerous voltages.

DON'T leave equipment switched on when it is unattended unless it is specifically stated that it is designed for unattended operation or has a standby mode.

Switch off using the switch on the equipment and make sure that your family know how to do this.

Special arrangements may need to be made for infirm or handicapped people.

DON'T use equipment such as personal stereos or radios so that you are distracted from the requirements of traffic safety. It is illegal to watch television whilst driving.

DON'T listen to headphones at high volume as such use can permanently damage your hearing.

DON'T obstruct the ventilation of the equipment, for example with curtains or soft furnishings. Overheating will cause damage and shorten the life of the equipment.

DON'T use makeshift stands and NEVER fix legs with wood screws—to ensure complete safety always fit the manufacturer's approved stand or legs with the fixings provided according to the instructions.

DON'T allow electrical equipment to be exposed to rain or moisture.

ABOVE ALL

- NEVER let anyone, especially children, push anything into holes, slots or any other opening in the case—this could result in a fatal electrical shock.
- NEVER guess or take chances with electrical equipment of any kind—it is better to be safe than sorry!

JVC