

JVC



MICRO COMPONENT SYSTEM

UX-QX3W

Consists of CA-UXQX3W and SP-UXQX1W

UX-QX3A

Consists of CA-UXQX3A and SP-UXQX1A

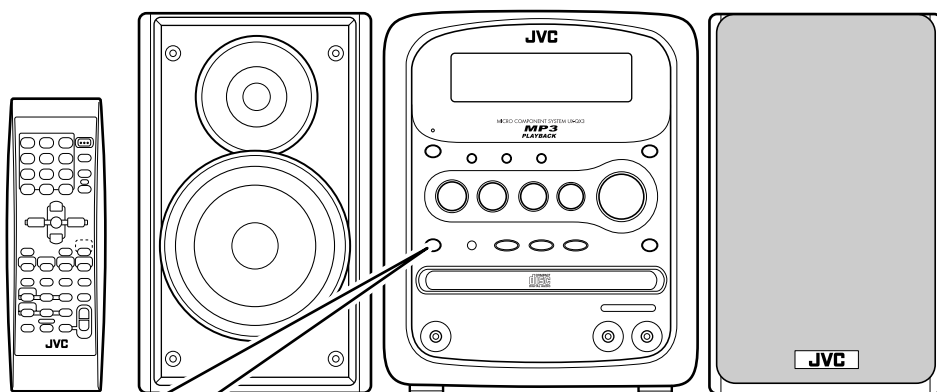

To disable the demonstration display, refer to page 7.

MP3
PLAYBACK

COMPACT
disc
DIGITAL AUDIO

INSTRUCTIONS

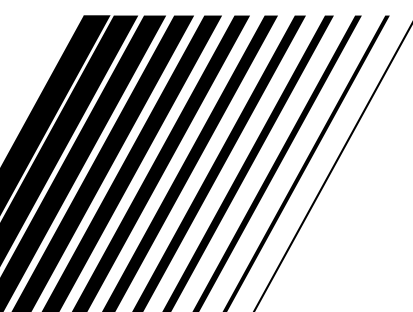

Warnings, cautions and others

CAUTION

To reduce the risk of electrical shocks, fire, etc.:

1. Do not remove screws, covers or cabinet.
2. Do not expose this appliance to rain or moisture.

CAUTION — **ON/OFF (STANDBY/ON) button!**

Disconnect the mains plug to shut the power off completely (the STANDBY lamp goes off). When installing the apparatus, ensure that the plug is easily accessible.

The **ON/OFF (STANDBY/ON) button** in any position does not disconnect the mains line.

- When the System is on STANDBY, the STANDBY lamp lights red.
- When the System is turned ON, the STANDBY lamp goes off.

The power can be remote controlled.

CAUTION

- Do not block the ventilation openings or holes. (If the ventilation openings or holes are blocked by a newspaper or cloth, etc., the heat may not be able to get out.)
- Do not place any naked flame sources, such as lighted candles, on the apparatus.
- When discarding batteries, environmental problems must be considered and local rules or laws governing the disposal of these batteries must be followed strictly.
- Do not expose this apparatus to rain, moisture, dripping or splashing and that no objects filled with liquids, such as vases, shall be placed on the apparatus.

IMPORTANT FOR LASER PRODUCTS

1. CLASS 1 LASER PRODUCT
2. **CAUTION:** Do not open the top cover. There are no user serviceable parts inside the unit; leave all servicing to qualified service personnel.
3. **CAUTION:** Visible and/or invisible class 1M laser radiation when open. Do not view directly with optical instruments.
4. REPRODUCTION OF LABEL: CAUTION LABEL, PLACED INSIDE THE UNIT.

CAUTION VISIBLE AND/OR INVISIBLE CLASS 1M LASER RADIATION WHEN OPEN. DO NOT VIEW DIRECTLY WITH OPTICAL INSTRUMENTS. IEC60825-1:2001 (ENG)	ATTENTION RAYONNEMENT LASER VISIBLE ET/OU INVISIBLE DE CLASSE 1M UNE FOIS OUVERT NE PAS REGARDER DIRECTEMENT AVEC DES INSTRUMENTS OPTIQUES. (FRA)	AVISO RADIACION LASER DE CLASE 1M VISIBLE Y/O INVISIBLE CUANDO ESTA ABIERTO, NO MIRAR DIRECTAMENTE CON INSTRUMENTAL OPTICO. (ESP)	VARNING SYNLIG OCH/ELLER OSYNLIG LASERSTRÅLNING, KLASS 1M, NÄR DENNA ÄR ÖPPNAD. RETRAKTA EJ STRÅLEN MED OPTISKA INSTRUMENT. (SWE)	注意 ここを開くと可視 及び/または不可視 のクラス1M レーザー放射が 出ます。 光学装置で直視 しないでください。 (JPN)	CAUTION VISIBLE AND/OR INVISIBLE CLASS 1 LASER RADIATION WHEN OPEN. DO NOT STARE INTO BEAM. FDA 21 CFR (ENG) LV44608-008A
--	---	---	---	--	--

Caution — Proper Ventilation

To avoid risk of electric shock and fire and to protect from damage, locate the apparatus as follows:

Top/Front/Back/Sides: No obstructions should be placed in the areas shown by the dimensions below.

Bottom: Place on a level surface. Maintain adequate air path for ventilation by placing on a stand with a height of 10 cm or more.

In addition, maintain the best possible air circulation.

Front view

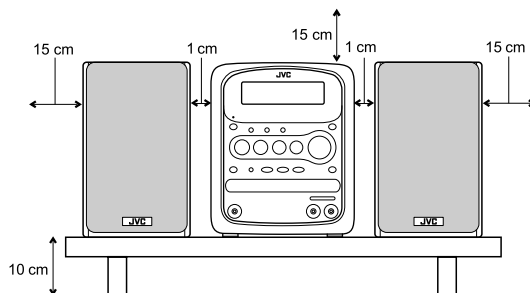

Side view

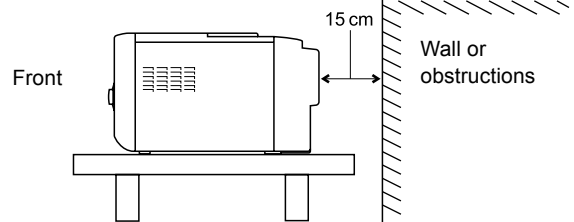

[European Union only]

Table of Contents

Introduction

Notes on Operations.....	2
Installation	2
Notes on Handling.....	2
Moisture Condensation	2
Listener's Etiquette.....	2
About CDs/CD-Rs/CD-RWs.....	2
Supplied Accessories.....	2

Preparation

Part Identification.....	3
Remote Control	4
Inserting Batteries into the Remote Control.....	4
Connections.....	5
Connecting the Antennas.....	5
Connecting the Speakers.....	6
Connecting a Digital Audio Player.....	7
Connecting the Power Cord.....	7
Disabling the Demonstration Display	7

Basic Operations and Settings

Basic Operations and Settings	8
Setting the Clock.....	8
Turning On/Off the System	9
Adjusting the Volume	9
Temporarily Turning Off the Sound (FADE MUTING).....	9
Emphasizing Bass Sound (AHB PRO).....	9
Sound Mode.....	9
Adjusting the Tone	10
α Sound	10
Changing the Illumination Color.....	11
Touch Illumination.....	11
Changing the Display Brightness (DIMMER).....	12
Auto Standby.....	12

Listening to the Radio

Listening to the Radio.....	13
Setting the AM Tuner Spacing	13
Tuning in to a Radio Station	14
Storing (presetting) Radio Stations	14
Tuning in to a Preset Radio Station.....	14

Listening to Discs

Listening to Discs	15
Specifying the Track (Direct Track Selection)	16
Repeat Playback	16
Program Playback.....	16
Random Playback	17

Listening to a Digital Audio Player

Listening to a Digital Audio Player.....	18
Listening to a Digital Audio Player readily (QP Link).....	18
Adjusting the Sound Input Level.....	18

Convenient Functions

Using the Timer	19
Sleep Timer	19
Playback Timer.....	20
Using the Snooze Function	22
Disc Lock.....	23

Reference

Maintenance.....	23
Warning Message	24
Troubleshooting.....	24
Specifications	25

Notes on Operations

Installation

- Install the System in a location with adequate ventilation to prevent internal heat buildup in the System.
- DO NOT install the System in a location near heat sources, or in a place subjected to direct sunlight, excessive dust or vibration.
- Install the System in a place which is level, dry and neither too hot nor too cold—between 5°C and 35°C.
- Leave sufficient distance between the System and the TV.
- Keep the speakers away from the TV to avoid interference with the TV.

Notes on Handling

■ Important cautions

Power cord

- Do not handle the power cord with wet hands.
- A small amount of power is always consumed while the power cord is connected to the wall outlet.
- When unplugging the power cord from the wall outlet, always grasp the plug, not the power cord.

To prevent malfunctions of the System

- There are no user-serviceable parts inside. If anything goes wrong, unplug the power cord and consult your dealer.
- Do not insert any metallic object into the System.
- Do not use any non-standard shape disc (like a heart, flower or credit card, etc.). It may damage the System.
- Do not use a disc with tape, stickers, or paste on it. It may damage the System.

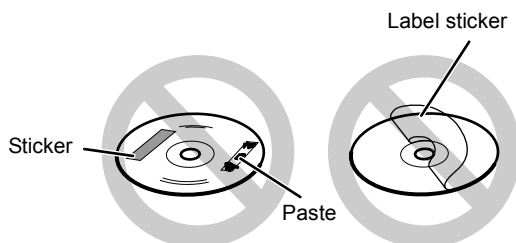

Note about copyright laws

Check the copyright laws for your country before recording from discs. Recording of copyrighted material may infringe copyright laws.

■ Safety precautions

When you are away

When away on travel or for other reasons for an extended period of time, disconnect the power cord from the wall outlet.

If water gets inside the System

- Turn the System off and disconnect the power cord from the wall outlet, then call the store where you made your purchase. Using the System in this condition may cause fire or electrical shock.

Moisture Condensation

Moisture may condense inside the lens on the System in the following cases:

- After starting to heat the room
- In a damp room
- If the System is brought directly from a cold place to warm place.



Should this occur, the System may malfunction. In this case, leave the System turned on for a few hours before use.

Listener's Etiquette

- When using the headphones, keep the volume at a moderate level to prevent over-stimulating your ears.
- When enjoying sound from the speakers, adjust the volume to a suitable level to avoid disturbing your neighbors. Especially at night, close the windows or use the headphones even though you listen to sound at a low volume.

About CDs/CD-Rs/CD-RWs

Confirm the marks on CDs/CD-Rs/CD-RWs

Use a CD/CD-R/CD-RW with the  or  logo. The System does not play back DVDs or Video CDs.

About CD-Rs/CD-RWs

- Use only "finalized" discs.
- You can play back a CD-R/CD-RW which has been recorded in the audio CD or MP3 format.
 - Do not play back any CD-R/CD-RW recorded in a format other than audio CD or MP3 format; otherwise, the speakers or other parts may be damaged by sudden loud volume.
- The System may not play back some discs or files due to their characteristics or recording conditions.
- Before using a CD-R/CD-RW, carefully read the cautions regarding the disc.

Supplied Accessories

Check to be sure you have all of the supplied accessories.

The number in parentheses indicates the number of the pieces supplied. If anything is missing, contact your dealer immediately.

- Remote control (1)
- Batteries (2)
- FM antenna (1)
- AM loop antenna (1)

Part Identification

The numbers in the figure indicate the pages where the details of the parts are.

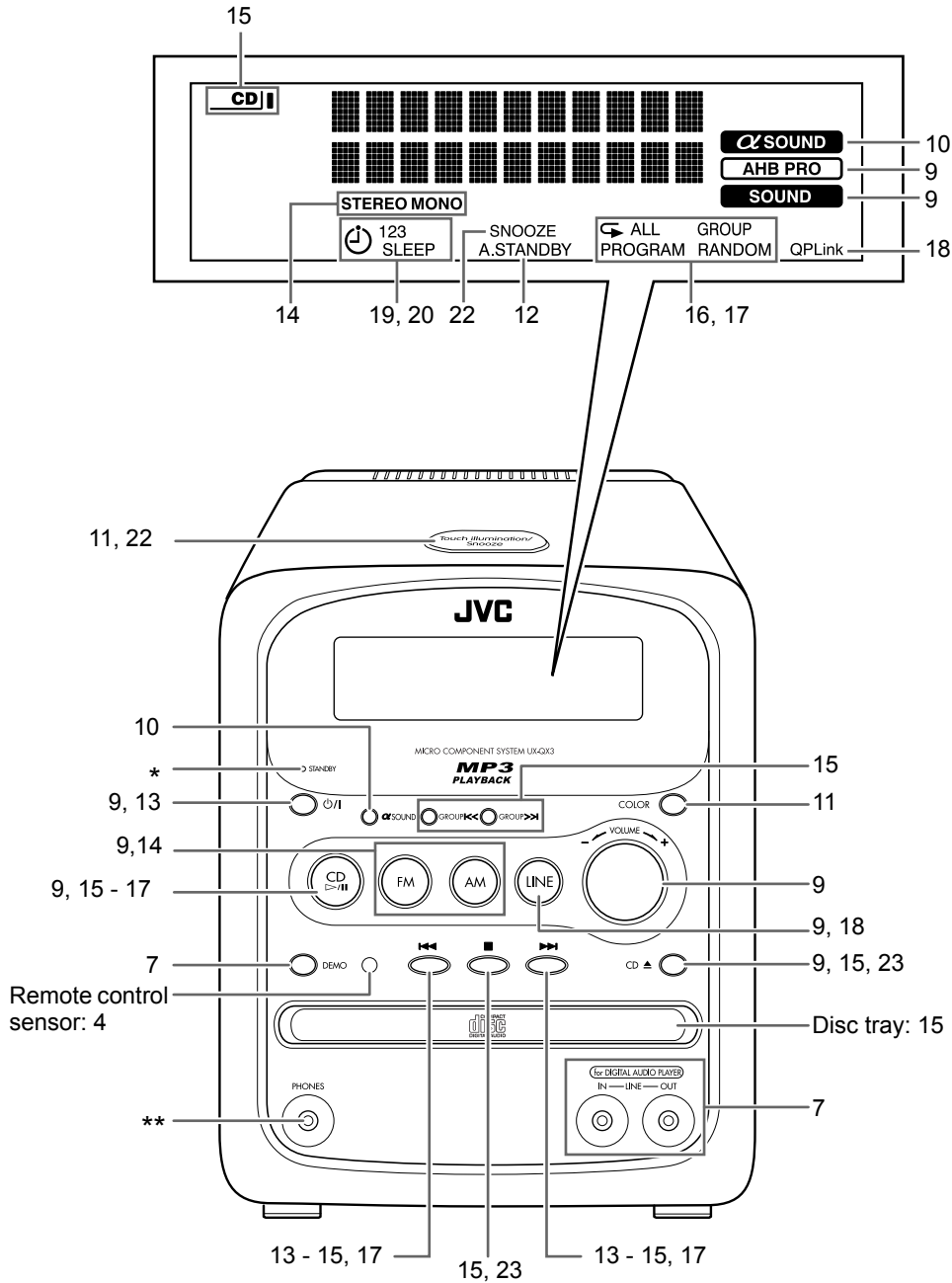

- * When the power is turned off, the STANDBY lamp lights red. When the power is turned on, the STANDBY lamp goes off.
- ** This terminal is for connecting a pair of headphones equipped with a stereo mini plug (not supplied). While the headphones are connected, the speakers do not produce any sound.

Remote Control

The numbers in the figure indicate the pages where the details of the parts are.

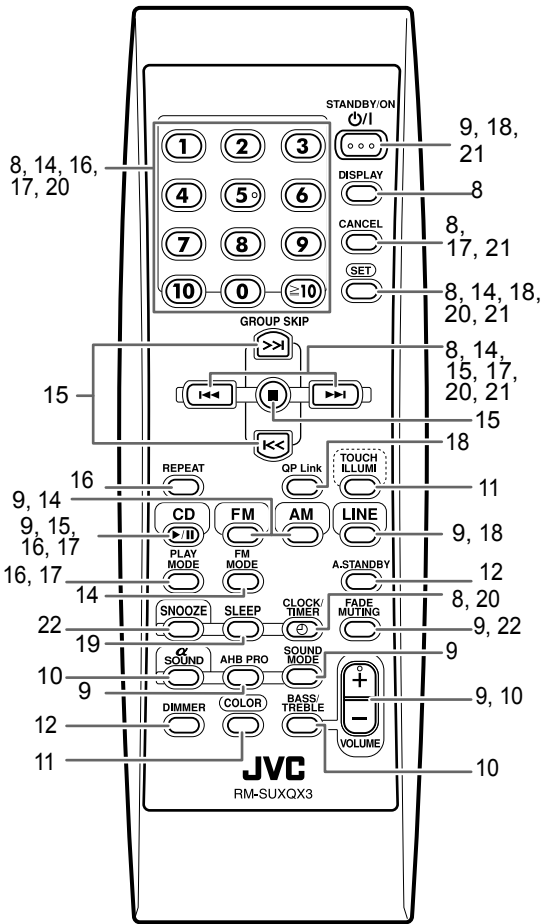

Inserting Batteries into the Remote Control

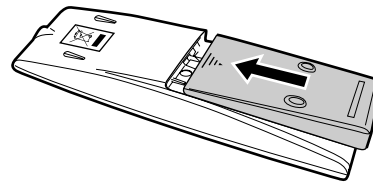
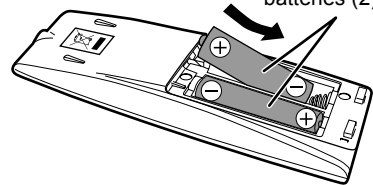
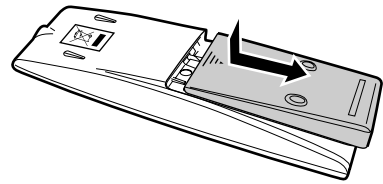

CAUTION

- Do not use a used battery and a new battery together.
- Do not use different types of batteries at the same time.
- Take out the batteries if the remote control is not to be used for a long time. Otherwise it may cause leakage.
- Dispose of batteries in the proper manner, according to federal, state, and local regulations.

Remote control operation

- When operating the remote control, point it toward the remote control sensor on the front panel.
- The effective distance between the remote control and the remote control sensor on the main unit is approximately 5 m.

Connections

Do not connect the AC power cord until all other connections have been made.

Connecting the Antennas

Connecting the AM antenna

1 Set up the AM loop antenna (supplied).

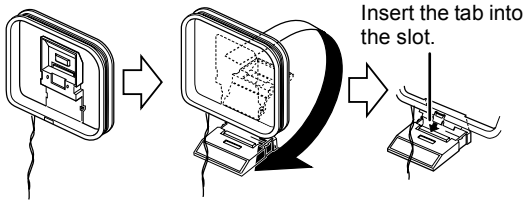

2 Connect the antenna cord.

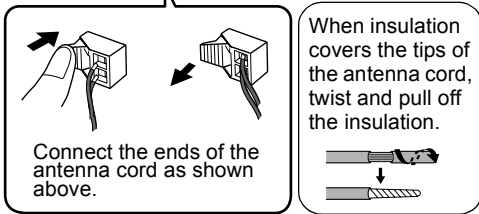
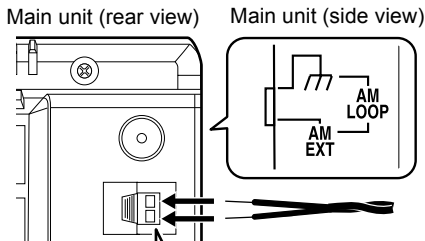

3 Turn the AM loop antenna to find the best position for radio reception.

- Place the AM loop antenna as far from the main unit as possible.
- Do not place the AM loop antenna on a metallic table or close to TV, personal computer, etc. It may result in bad radio reception.

When radio reception with the AM loop antenna is poor

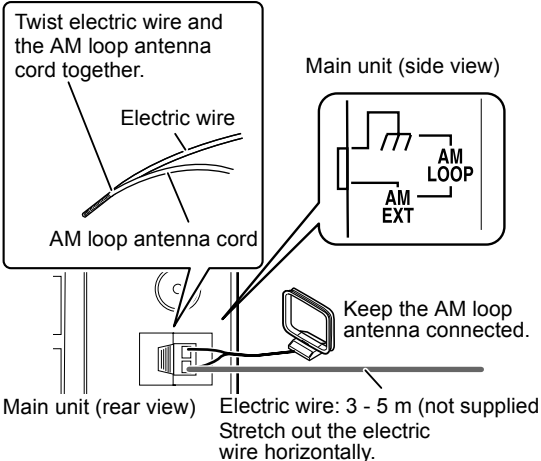

Connecting the FM antenna

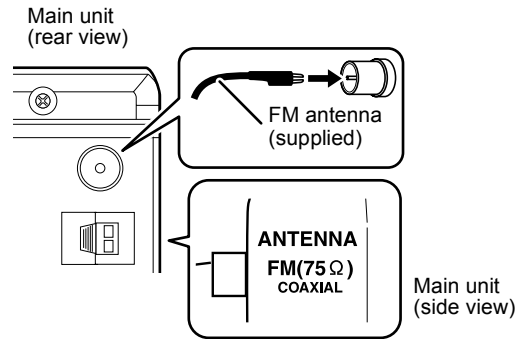

Stretch out the FM antenna to the best position for radio reception, then fix it with adhesive tape.

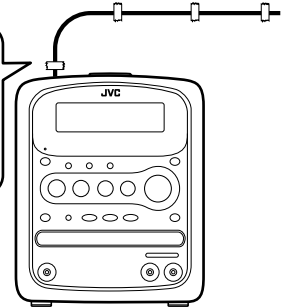

When radio reception is poor with the supplied FM antenna, or when using a communal antenna

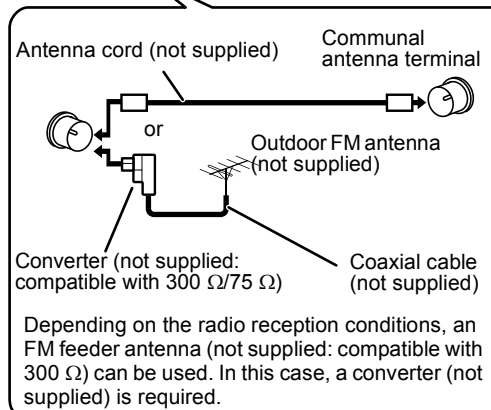
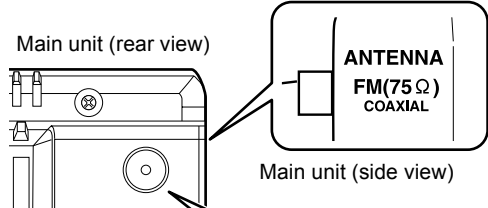

For details of connecting a separately sold antenna, refer to the instruction manual for the antenna or converter.

When positioning the antennas, find the best position for reception while listening to an actual radio program (refer to "Listening to the Radio" (page 13)).

Connecting the Speakers

There is no difference between the left and right speakers.

After connecting the speakers, gently pull the speaker cords to make sure that they are firmly connected.

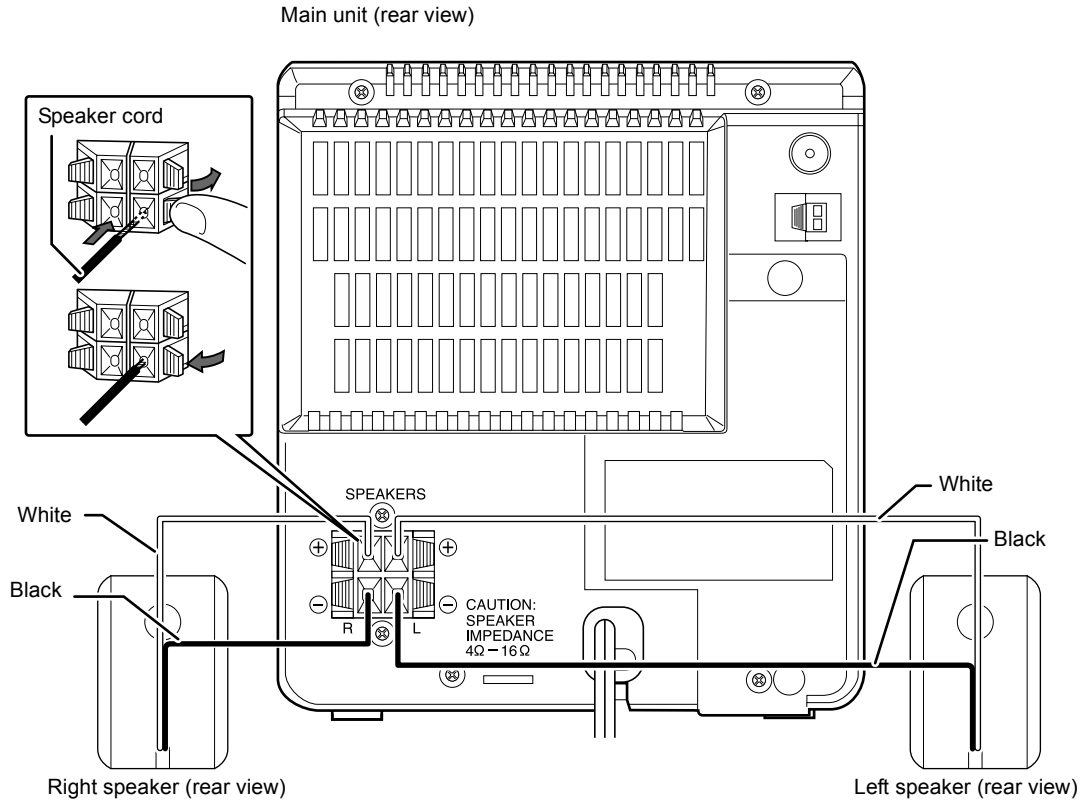

CAUTION

- Do not short-circuit the ⊕ and ⊖ speaker terminals. Otherwise it may damage the System.
- Do not connect other speakers together with the supplied speakers. The change in impedance may damage the System.

NOTE

- Improper speaker cord connection spoils the stereo effect and sound quality.
- The impedance of speakers connected to the System must be within the range of 4 Ω to 16 Ω.
- A cooling fan is built into the main unit. The internal cooling fan automatically rotates to dissipate generated heat. To ensure sufficient cooling, leave a space of at least 1 cm between the main unit and the speakers or other objects.
- The supplied speakers are not magnetically shielded. Keep enough distance between the speakers and TV so that they do not cause color irregularity on the TV.

You can detach the speaker grille.

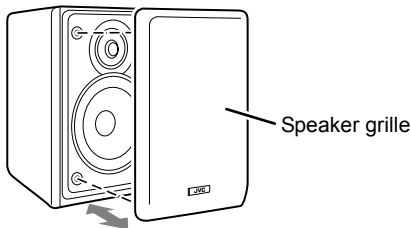

Connecting a Digital Audio Player

■ To listen to a Digital Audio Player

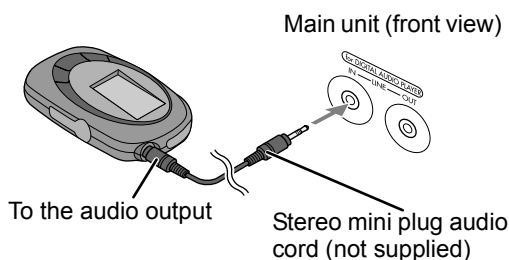

NOTE

- The System automatically switches the source to LINE when the connected Digital Audio Player starts to play—QP Link (☞ page 18).
- The sound signal from the Digital Audio Player cannot be transmitted through the LINE OUT jack.

■ To record on a Digital Audio Player from the System

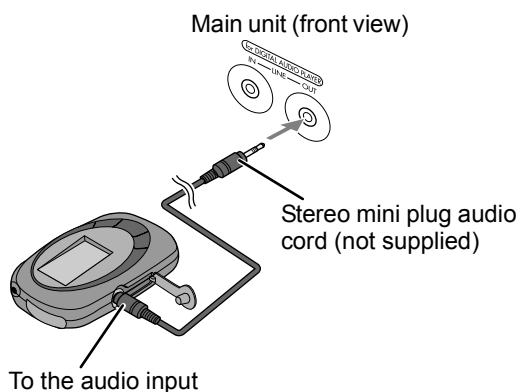

NOTE

- Before recording on a Digital Audio Player, deactivate QP Link (☞ page 18) or do not connect the Digital Audio Player to the LINE IN jack; otherwise, LINE will be selected as the source and the recording will stop.

Connecting the Power Cord

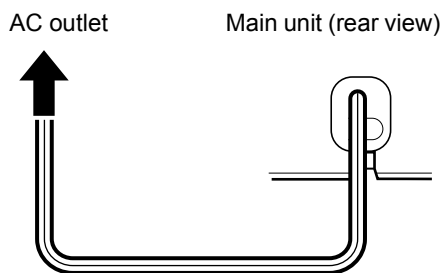

- After making all other necessary connections, connect the power cord.
- When you unplug the power cord or if a power failure occurs, the clock is reset to "0:00" and the timers will be canceled. You will need to set the clock (☞ page 8) and the timers (☞ page 19 -21) again.

Disabling the Demonstration Display

When you connect the power plug into the AC outlet, "Hello" then "DEMO START!" appears on the display window and the demonstration display starts.

To deactivate the demonstration display, follow the procedure below:

While the power is turned off...

Hold down  on the main unit until "DEMO CLEAR" appears on the display window.

■ To activate the demonstration display again

While the power is turned off...

Hold down  on the main unit until "Hello" appears on the display window.

- The System will be turned on and the demonstration display will start.

NOTE

- To stop the demonstration display, operate the System. "DEMO OFF" appears on the display window.

Basic Operations and Settings

About this manual

In this manual, operations mainly using the remote control are explained; however, some buttons on the main unit work the same way as those on the remote control. You can use either button in this case.

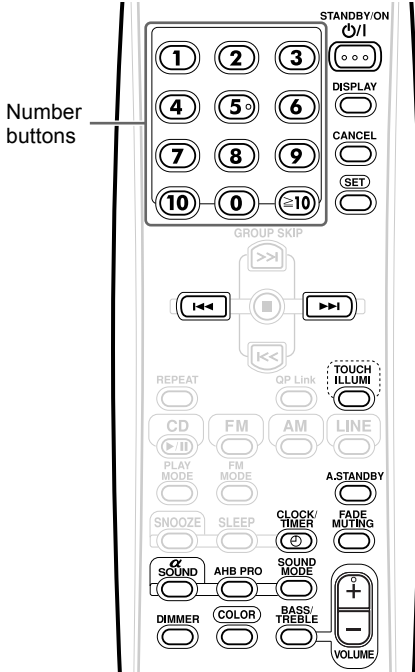

Setting the Clock

You can set the clock when the System is turned either on or off.

1 Press .

- If you have already set the clock before and you want to adjust it, press four times to show the clock setting display.



2 Press or repeatedly to set the hour, then press .

- You can also use the number buttons to specify the hour. Refer to "Using the number buttons" on the right column.

3 Press or repeatedly to set the minutes, then press .

- You can also use the number buttons to specify the minutes. Refer to "Using the number buttons" on the right column.

4 Press or repeatedly to set the day of the week.

5 Press .

- "CLOCK SET!" appears on the display window and the built-in clock starts working.

NOTE

- While setting the clock, you can return to the previous step by pressing .
- Holding down or changes the setting value rapidly.

■ To display the clock while using the System

Press .

- To return to the source display, press again.

NOTE

- The hour indication is displayed using the 24-hour system.
- The clock will gain or lose approximately 1 minute per month.
- If the power cord has been unplugged or a power failure occurs, you will have to set the clock again.

Using the number buttons

Examples:

3:

13: → →

20: → →

123: → → → →

- 100 and above is used when you select an MP3 track.

Turning On/Off the System

Press .

- While the System is turned off, pressing one of the buttons below also turns on the System.

Remote control: 

Main unit: 

The corresponding source will be selected by pressing one of these buttons except . Playback automatically starts if the selected source is ready.

Adjusting the Volume

Press .

NOTE

- You can also adjust the volume by turning the VOLUME control on the main unit.
- You can adjust the volume within the range of "0" to "40".



Temporarily Turning Off the Sound (FADE MUTING)

Press .

- "FADE MUTING" appears on the display window and the volume will be set to minimum.
- To restore the sound, press  again.

Emphasizing Bass Sound (AHB PRO)

Press .

- Each time you press , the AHB PRO (Active Hyper Bass PRO) function changes between "AHB PRO ON" (initial setting) and "AHB PRO OFF."
- When the AHB PRO function is activated,  lights on the display window.

Sound Mode

Sound mode
A combination of JVC sound technologies enables you to select the desired sound pattern.

Press  repeatedly.

- Each time you press , the display changes as follows:

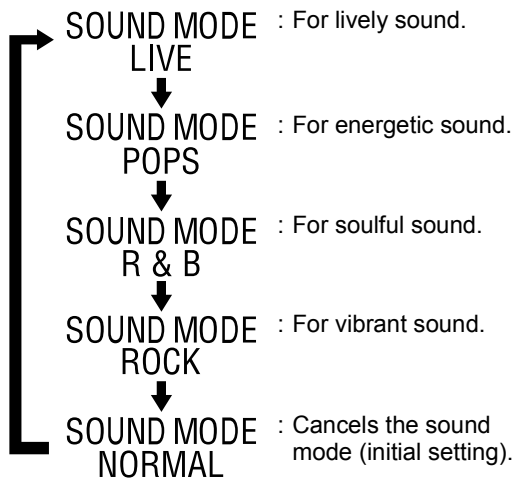

- When the sound mode is set to an item other than "SOUND MODE NORMAL,"  lights on the display window.

NOTE

- When α SOUND is activated (page 10), using the SOUND MODE cancels α SOUND automatically and vice versa.
- This function does not affect recording sound.

Adjusting the Tone

NOTE

- Before adjusting, set the sound mode to "SOUND MODE NORMAL" (👉 page 9). When the sound mode is set to any item other than "SOUND MODE NORMAL" and you press , "NO OPERATE" appears on the display window and you cannot adjust the tone.

1 Press  repeatedly to display "BASS" or "TREBLE."

BASS : Adjusts the bass sound.

TREBLE: Adjusts the treble sound.

2 While "BASS" or "TREBLE" is displayed on the display window,

press  repeatedly to adjust the tone.

- You can adjust the tone level within the range of -5 to +5.
- The display returns to the source display in a few seconds.

NOTE

- This function does not affect recording sound.

α Sound

α Sound

α (alpha) waves are regarded as one type of brain wave that is emitted when a person is relaxed. JVC's α SOUND function is designed to produce natural and comfortable sound that makes you feel relaxed. The natural effect is completed by

- 1) modulation which adds fluctuation with the α wave frequency to subtracted waves (left-right indirect sound).
- 2) sound correction for covering the middle range of waves in music signals which naturally tend to dissipate.

Press  repeatedly.

- Each time you press , the display changes as follows:

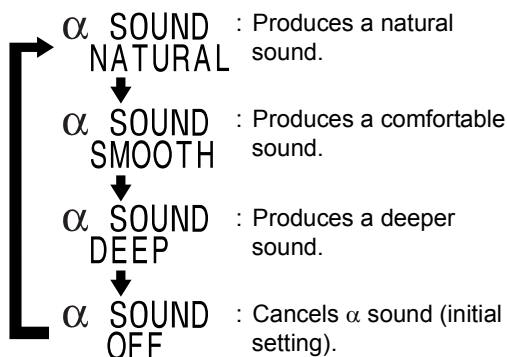

- When α sound is set to an item other than "α SOUND OFF,"  lights on the display window.

NOTE

- When the SOUND MODE is activated (👉 page 9), using α SOUND cancels the SOUND MODE automatically and vice versa.
- This function does not affect recording sound.

Changing the Illumination Color

Press  repeatedly.

- Each time you press , the illumination color for the front panel changes as follows:

UX-QX3W

RAINBOW → SPACE → SEASONS →
 CANARY → ECOLOGY → MARSHMALLOW
 → COSMIC → SHERBET → SODA →
 POP CANDY → POLAR STAR → PEARL →
 KIWI → ROSE QUARTZ → AMETHYST →
 EMERALD → TOPAZ → AQUAMARINE →
 SOFT LIGHT1 → SOFT LIGHT2 → Back to the beginning

UX-QX3A

LAVENDER → RAINBOW → OCEAN →
 SPACE → AQUAMARINE → VENUS →
 SAPPHIRE → POP CANDY →
 PEPPERMINT → SNOW WHITE →
 EMERALD → PURPLE → SUN FLOWER
 → OLIVE → SAKURA → AQUA GREEN →
 BORDEAUX → APRICOT → SOFT LIGHT1
 → SOFT LIGHT2 → Back to the beginning

NOTE

- While the System is turned on and Touch illumination is activated, touching  changes the illumination color. Refer to "Touch Illumination" on the right.

Touch Illumination

Even while the System is turned off, you can illuminate the front panel temporarily—Touch illumination.

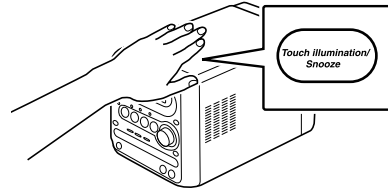

■ To set Touch illumination

Press .

- Each time you press , Touch illumination setting changes as follows:

ILLUMI ON : Activates Touch illumination (initial setting).



ILLUMI OFF: Cancels Touch illumination.

■ To illuminate the front panel temporarily

While the System is turned off...

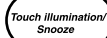
Touch  on the main unit.

The front panel is illuminated for about 5 seconds.

NOTE

- Activating Touch illumination heats up the rear of the main unit even though the System is turned off. This is not a malfunction.

Changing the Display Brightness (DIMMER)

Press  repeatedly.

- Each time you press , the brightness of the front panel changes as follows:

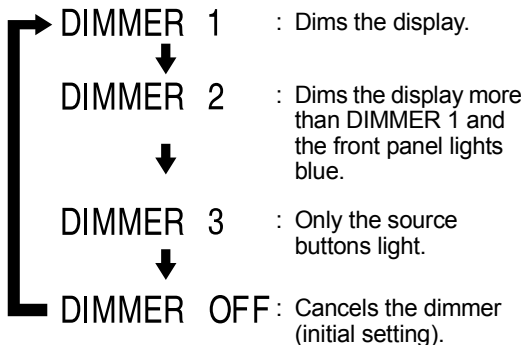

NOTE

- Pressing  also cancels the dimmer.
- You cannot turn off the illumination color even though the dimmer is activated.
- While the dimmer is deactivated, the illumination color for the source buttons lights in or flashes as follows:
 - While turning up the volume, the source buttons light in red.
 - While turning down the volume, the source buttons light in blue.
 - When pressing a source button, the selected illumination color flashes three times.
 - While a disc is paused, the source buttons light in yellow and the yellow light flashes three times.

Auto Standby

The System is turned off (on standby) automatically with the Auto Standby function activated.

While any source other than FM or AM is selected...

Press .

- "A.STANDBY SET" appears on the display window.

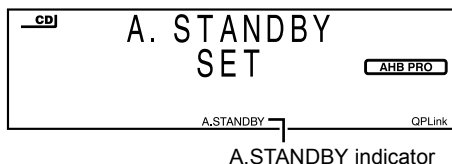

The A.STANDBY indicator starts flashing in the following cases:

- While CD is selected as the source and the disc is stopped.
- While LINE is selected as the source and the Digital Audio Player is stopped or the sound signal from the Digital Audio Player is too weak.

The System will be turned off automatically if no operation is done for about 3 minutes while the indicator is flashing.

- "A.STANDBY OFF" starts flashing for 20 seconds before the System is turned off.

■ **To cancel the Auto Standby function**

Press  again.

"A.STANDBY CANCEL" appears on the display window and the A.STANDBY indicator goes off.

NOTE

- Leaving the volume at "0" is not the same as producing no sound, and therefore does not start the Auto Standby function.

Listening to the Radio

The System can receive FM and AM radio broadcasts.

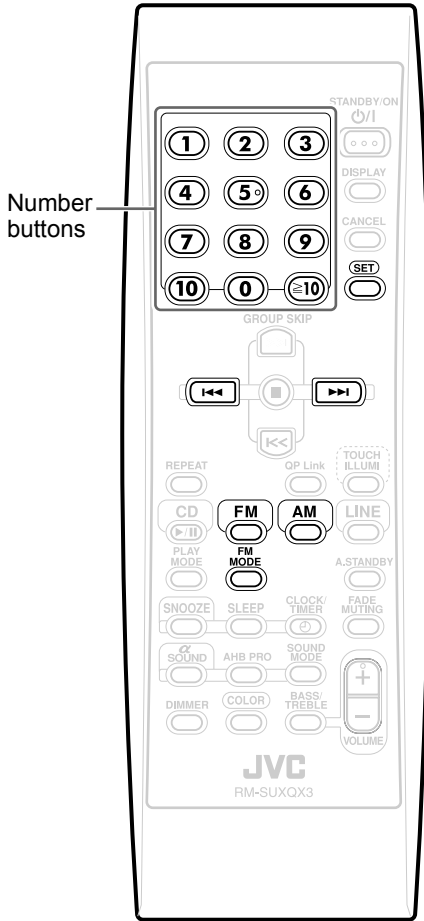



Setting the AM Tuner Spacing

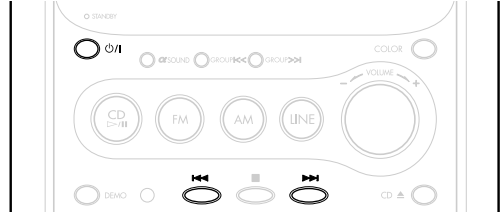

Before operating the tuner, it is required to select the appropriate AM space interval used for your area.

On the main unit:



While the System is turned off...

To select 10 kHz spacing, while holding down , press . "AM 10kHz STEP" appears on the display window.

To select 9 kHz spacing, while holding down , press . "AM 9kHz STEP" appears on the display window.

NOTE

- If the spacing is switched, the stored radio stations will be erased.

Tuning in to a Radio Station

1 Press or .

Example: When FM is selected as the source

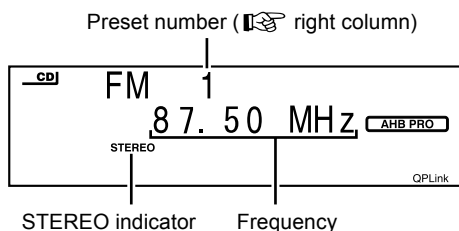

2 Press or repeatedly to select a radio station (frequency).

- You can also select a radio station using the automatic tuning. Refer to "Automatic tuning" below.
- When the System receives an FM stereo broadcast, the STEREO indicator lights on the display window.

■ Automatic tuning

Hold down or until the frequency starts changing.

When the System receives a broadcast, the frequency automatically stops changing.

To manually stop searching, press or .

■ To switch the FM reception (stereo/monaural)

If the FM station has poor reception, press . The MONO indicator lights on the display window. Reception will improve though stereo effect is lost.

To restore the stereo effect, press again (MONO indicator goes off).

Storing (presetting) Radio Stations

You can store up to 30 FM and 15 AM radio stations.

- There is a time limit in doing the following steps. If the setting is canceled before you finish, start from step 1 again.

1 Tune in to a radio station you want to store.

- Refer to "Tuning in to a Radio Station" shown on the left.

2 Press .

- The preset number starts flashing for about 5 seconds.

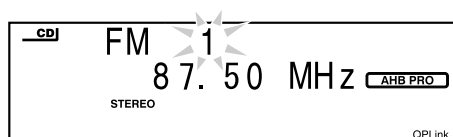

3 While the preset number is flashing, press the number buttons to select the preset number which you want to store the station into.

- Refer to "Using the number buttons" (page 8).

4 While the selected number is flashing, press .

- "STORED" appears on the display window and the tuned radio station is stored.

NOTE

- The type of FM reception (stereo/monaural) is also stored (left column).
- Storing a new station to a used number erases the previously stored station.

Tuning in to a Preset Radio Station

While FM or AM is selected as the source...

Use the number buttons to select the preset number of the radio station you want to tune in to.

Refer to "Using the number buttons" (page 8).

Listening to Discs

The System can play back regular CDs and finalized CD-Rs/CD-RWs (recorded in audio CD or MP3 format).

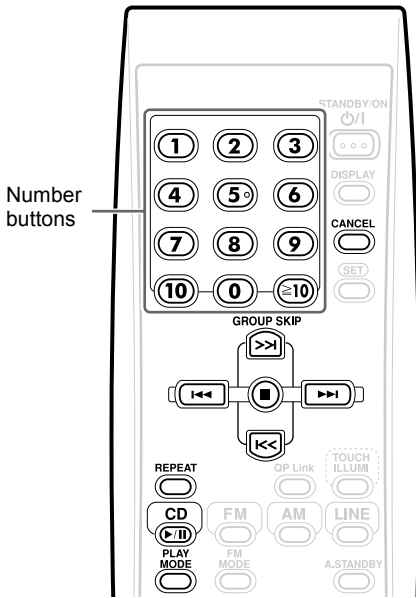

	Operation
Play	Press .
Stop	Press .
Pause	Press during playback. Pressing again resumes playback.
Skip	/ : Press the button repeatedly. GROUP SKIP / : Press the button to skip groups (only for MP3 disc).
Fast forward/ reverse (Search)	/ : Hold down the button during playback.
Eject	Press on the main unit.

1 Press on the main unit.

- The disc tray comes out.

2 Place a disc on the disc tray.

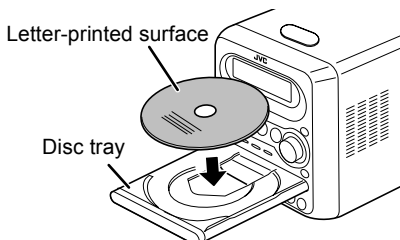

- When you want to play an 8 cm disc, place it on the inner circle of the disc tray.

3 Press to start playback.

- While an audio CD is being played back...

CD indicator
(Lights while a disc is stopped and flashes while a disc is being played back or paused.)

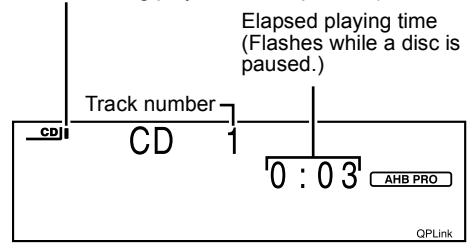

- While an audio CD is stopped...

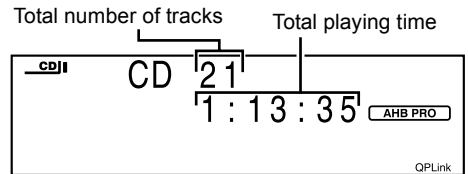

- While an MP3 disc is being played back...

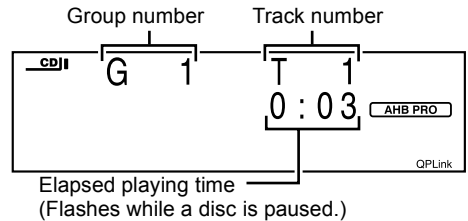

- Before the elapsed playing time appears, the following information is scrolled one after another on the display window:

GROUP (folder name) → TRACK (file name) → TITLE (track title)* → ARTIST (artist name)* → ALBUM (album name)*

* The information is scrolled if the tag information is recorded.

- While an MP3 disc is stopped...

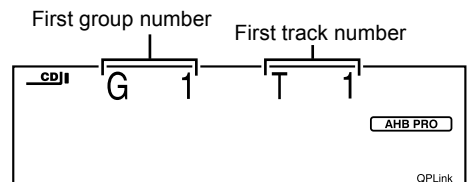

- When an MP3 disc is stopped, GROUP (folder name) and TRACK (file name) are scrolled on the display window.

NOTE

- Only alphanumeric characters are displayed properly as disc information.

Specifying the Track (Direct Track Selection)

Press the number buttons to select the track you want to listen to.

- Refer to "Using the number buttons" (👉 page 8).

Repeat Playback

This function allows you to listen repeatedly to the same track (or group: only for MP3 disc).

Press  repeatedly to select the repeat mode.

- Each time you press , the display changes as follows:

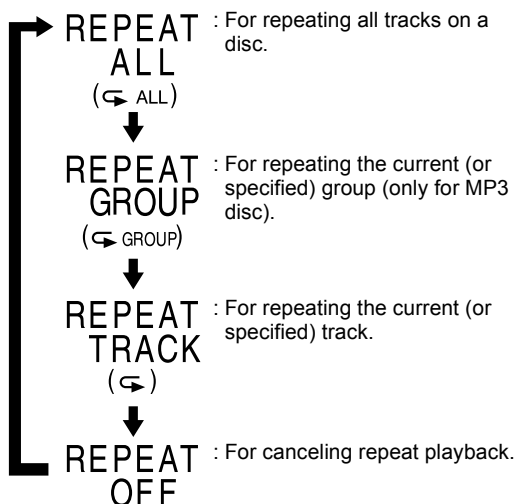

Example: When "REPEAT ALL" is selected

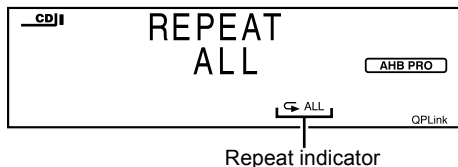

NOTE

- Ejecting the disc or turning off the System also cancels repeat playback.

Program Playback

This function allows you to program up to 99 tracks.

While playback is stopped...

1 Press  repeatedly to select "PROGRAM."

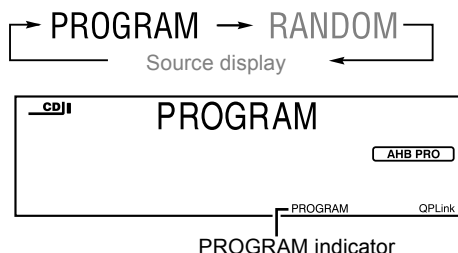

2 Press the number buttons to select the track numbers.

- Refer to "Using the number buttons" (👉 page 8).

For audio CD

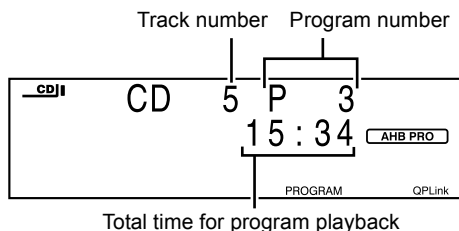

For MP3 disc

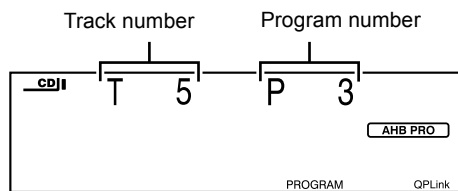

3 Press  to start playback.

NOTE

- When you try to program a 100th track, "MEMORY FULL" appears on the display window.
- When total time for program playback reaches 1 hour and 40 minutes, "--:--" appears on the display window.

■ To confirm the programmed track order

While playback is stopped...
Press or repeatedly.

■ To add tracks

You can add a track as the last track in the program.
While playback is stopped...
Press the number buttons to select the track number you want to add.

- Refer to "Using the number buttons" (page 8).

■ To erase the last track

While playback is stopped...

Press .

■ To erase the stored program

While playback is stopped...

Hold down .

■ To cancel the program playback

While playback is stopped...
Press repeatedly until the source display appears on the display window.

- This operation does not erase the stored program.

NOTE

- Ejecting the disc or turning off the System erases stored program and cancels program playback.

Random Playback

This function allows you to listen to tracks in random order.

While playback is stopped...

1 Press repeatedly to select "RANDOM."

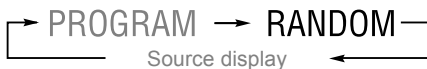

RANDOM indicator

- All the tracks are played back once.

2 Press to start playback.

NOTE

- Pressing repeatedly does not return to the previous track but returns to the beginning of the current track.

■ To cancel the random playback

While playback is stopped...

Press repeatedly until the source display appears on the display window.

NOTE

- Ejecting the disc or turning off the System also cancels random playback.

Notes on MP3

- The System can only recognize sound file (tracks) types with the extension code "MP3" or "mp3," which can be in any combination of upper or lower case.
- It is recommended that you record MP3 tracks at a 44.1 kHz sampling frequency, using a 128 kbps data transfer rate.
- Some MP3 tracks may not be played back because of their characteristics or recording conditions.
- This System can only play a disc in ISO 9660 Level 1 or Level 2 format.
- MP3 discs require a longer readout time than normal discs.
- This System plays back MP3 tracks as follows:

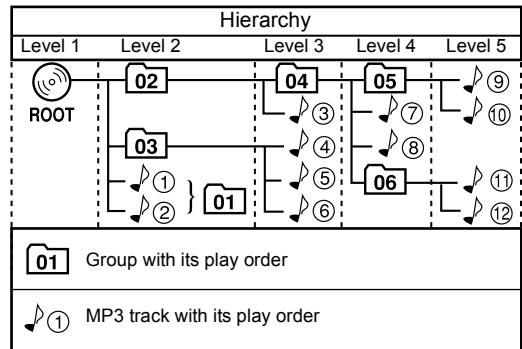

- The System can recognize up to 999 tracks in a disc. Also, the System can recognize up to 256 tracks per group and up to 99 groups in a disc.
 - Even if a folder contains no playable files, the folder is also counted in the total folder number.
 - Playable files which do not belong to any groups are handled as Group 1.

Using the Timer

Set the clock beforehand (👉 page 8).

The System is equipped with the two timers: the sleep timer and the playback timer. You can enter up to three timer settings in total for the playback timer (👉 page 20).

- The playback timer settings remain in memory until you change it.

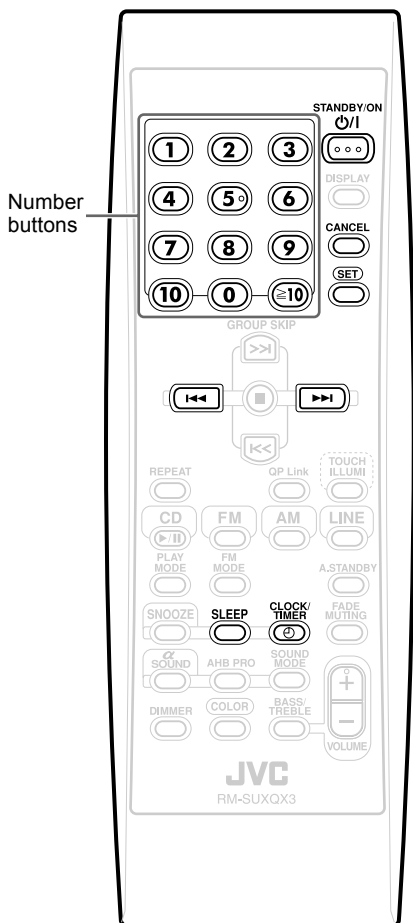

Sleep Timer

When the specified time passes, the System is automatically turned off.

Press repeatedly.

- Each time you press , the time display (in minutes) changes as follows:

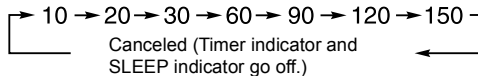

Example: When setting the sleep timer to 60 minutes

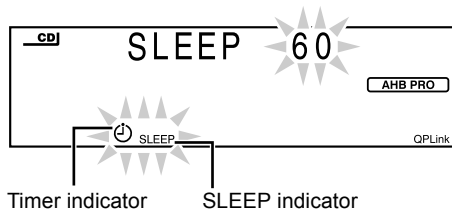

NOTE

- When you set the sleep timer, the display window automatically dims.
- If the clock has not been set, "CLOCK ADJUST!" appears on the display window. You need to set the clock first (👉 page 8).

■ To change the sleep timer setting

Press repeatedly to select the time again.

■ To confirm the sleep timer setting (remaining time)

Press .

Playback Timer

With the playback timer, you can wake up with your favorite music.

1 Prepare the source you want to play back.

Source	Operation
CD	Insert a disc (👉 page 15).
FM/AM	Preset the radio station you want to listen to (👉 page 14).
LINE	Set the playback timer function on the Digital Audio Player connected to the LINE IN jack. Follow the instruction manual for the Player.

2 Press repeatedly to select "TIMER1," "TIMER2," or "TIMER3," then press .

Example: When "TIMER1" is selected

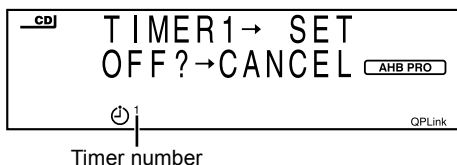

3 Set the starting time and ending time.

- Repeat the procedure below to set the time:

Press  or  repeatedly to enter the time, then press .

You can also use the number buttons to enter the time. Refer to "Using the number buttons" (👉 page 8).

Example: When you set the playback time from 7:00 a.m. to 7:30 a.m.

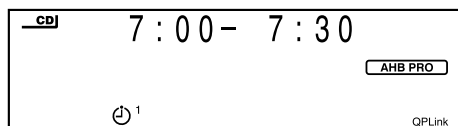



4 Press or to select "ONCE" or "WEEKLY," then press .

ONCE: Works once.

WEEKLY: Works weekly.

5 Press or repeatedly to select the desired day of the week, then press .

- Each time you press  or , the display changes as follows:

When "ONCE" is selected in step 4

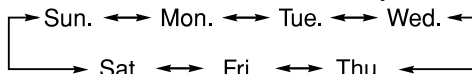

When "WEEKLY" is selected in step 4

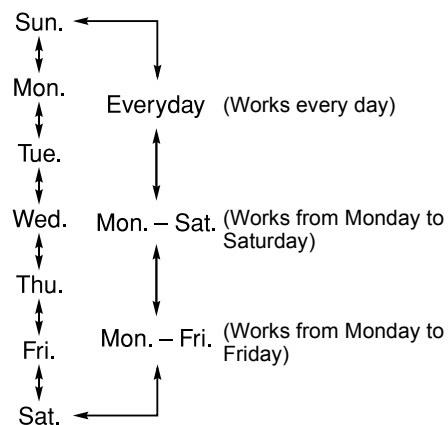

6 Press or repeatedly to select the source you want to play back, then press .

Example: When you select "AM" as the source

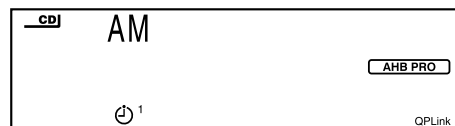





- When you select "FM," "AM," or "CD/MP3," go to step 7.
- When you select "LINE," go to step 8.

7 Press  or  repeatedly to select the following, then press .

When "FM" or "AM" is selected as the source in step 6: Select the preset number of the radio station you want ( page 14).

When "CD/MP3" is selected as the source in step 6: Select the group (for only MP3 disc) and track number you want to play back first.

- You can also use the number buttons to select the preset number, group number, and track number. Refer to "Using the number buttons" ( page 8).

8 Press  or  repeatedly to adjust the playback volume, then press .

- The settings appear one after another for confirmation on the display window.
- You can also use the volume buttons or number buttons to adjust the playback volume. Refer to "Using the number buttons" ( page 8).

9 When you set the playback timer while the System is turned on, press

STANDBY/ON



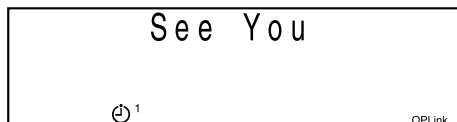

to turn off the System.

- The playback timer is available only while the System is turned off.



NOTE

- You can return to the previous step by pressing .
- You can quit the playback timer settings by pressing  as required. The settings will not be stored.

When the playback timer starts, the volume gradually increases to the selected level.

- You can turn off the volume temporarily while the playback timer is working. Refer to "Using the Snooze Function" on page 22.

■ To cancel the playback timer

In step 2 on page 20, select the timer number you want to cancel, then press .

Even though you cancel the playback timer, the setting remains stored.

■ To activate the playback timer again

In step 2 on page 20, select the timer number you want to activate, then press . The settings appear on the display window.

NOTE

- To activate two or three timers, leave an interval at least 3 minutes between the ending time of the first timer and the starting time of the second one. Otherwise the second timer does not work.
- When the power cord is disconnected or a power failure occurs, the timer settings may be lost. If the settings are lost, set the clock and timers again.

Using the Snooze Function

While the playback timer (☞ page 20) is working to play the selected source, you can turn off the sound temporarily by touching **Touch Illumination/ Snooze** on the main unit.

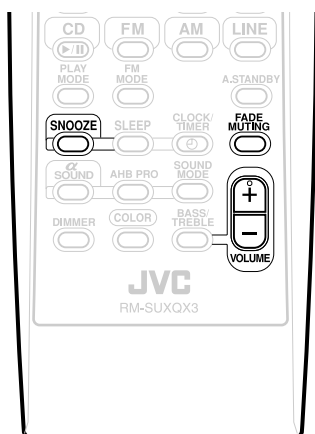
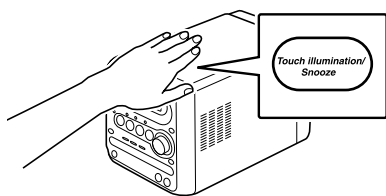

■Using the snooze function

Touch **Touch Illumination/ Snooze** on the main unit while the playback timer is working and playing the selected source.

The sound can be turned off up to three times.

When you touch **Touch Illumination/ Snooze** four times, the System will be turned off.

After 5 minutes from when you touch **Touch Illumination/ Snooze** ...

- At the first touch:
The volume is turned up gradually to the preset level.
- At the second and third touch:
The volume is set to the preset level.
- At the fourth touch:
The System is turned off.
- To cancel the snooze function, adjust the volume or press **FADE MUTING** while the volume is turned off.

NOTE

- When CD is selected as the source for the playback timer, insert a disc which contains more than 20 minutes of sound to use the snooze function.

■Setting the snooze function

Press **SNOOZE**.

- Each time you press **SNOOZE**, the snooze function changes between "SNOOZE ON" and "SNOOZE OFF" (initial setting).
- When the snooze function is activated, SNOOZE indicator lights on the display window.

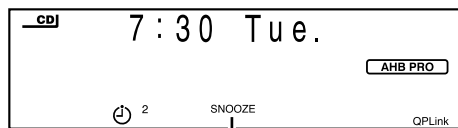

SNOOZE indicator

- While the snooze function is in operation, the SNOOZE indicator flashes on the display window.

Disc Lock

You can prohibit disc ejection.

On the main unit ONLY:

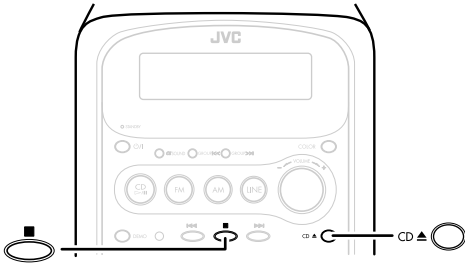

When the System is turned off...

While holding down , **press**  **on the main unit.**

The disc tray is locked.



Even if you press , "LOCKED" appears on the display window and the disc does not come out.

■ To cancel the disc lock

While the System is turned off...

Carry out the operation explained above once again.



Maintenance

Handling discs

- When removing the disc from its case, hold it at the edge while pressing the center hole lightly.
- Do not touch the shiny surface of the disc, or bend the disc.
- Put the disc back in its case after use to prevent warping.
- Be careful not to scratch the surface of the disc.
- Avoid exposure to direct sunlight, extreme temperature, and moisture.

Cleaning discs

Signal surface

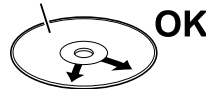

Wipe a disc from the center outward with a soft cloth.

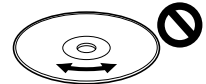

Scratches concentrated on a certain part cause sound to skip.

- Be sure not to use thinners, benzenes, cleaners for analog records, or other chemical agents.

Cleaning the System

- Gently dust the cabinet surface with a soft dry cloth. When the cabinet is excessively dirty, dampen the cloth with a neutral detergent diluted with water, wring out the cloth, then wipe the cabinet with the dampened cloth followed by a soft dry cloth.
- Do not wipe the cabinet with thinners or benzenes. Wiping it with these agents may cause discoloration of the cabinet or removal of the paint. Do not spray insecticides or other highly volatile agents onto the cabinet. Do not leave pieces of rubber or plastic on the cabinet for a long period.

Warning Message

Message	Meaning	Possible solution
CD NO DISC	Disc is not loaded.	Place a disc.
	Disc is placed upside down.	Place a disc with the label side up.
	Unplayable disc is loaded.	Replace a disc.

Troubleshooting

Check the following points before contacting the JVC service center.

Problem	Possible cause	Possible solution	Reference page
No sound is produced from the speakers.	Improper connection.	Connect all cords properly as in "Connections."	5
	Headphones are connected.	Disconnect the headphone plug.	3
	The MP3 disc is recorded utilizing "packet writing."	The System cannot play back this type of MP3 disc. Replace the disc.	–
The clock display is flashing.	The System was turned off because of a power cut. The power cord was disconnected.	Set the clock again.	8
Disc playback does not start.	Moisture has condensed on the lens.	Leave the System turned on for a few hours, then operate the System.	2
Adjustments or settings are suddenly canceled before you finish.	There is a time limit.	Repeat the procedure again.	–
A certain point on a disc cannot be played back properly.	The disc is scratched or dirty.	Clean or replace the disc.	23
Certain tracks on an MP3 disc cannot be played back.	These tracks were recorded in a format other than MP3 format.	The System cannot play back such tracks. Replace the disc.	–
A radio station cannot be received.	No antenna is connected.	Connect an antenna.	5
A whirring noise is produced.	The System is located close to TV, personal computer, or other electrical appliance.	Place the System away from TV, computer, or other electrical appliance.	2
The timer does not function.	The System is turned on.	After setting the timer, turn off the System.	21
You cannot operate the System through the remote control.	There is an obstruction blocking the remote sensor on the System.	Remove the obstruction.	–
	The remote control batteries are running low.	Replace the batteries.	4
Operations are disabled.	The built-in microprocessor may be malfunction due to external electrical interference.	Disconnect the power cord, and then connect it back in.	–

■ CD receiver section (CA-UXQX3W/CA-UXQX3A)

Amplifier

Output power	20 W × 2ch (THD 10%/4 Ω)
Input terminal	LINE IN × 1: 500 mV/47 kΩ: LEVEL1 250 mV/47 kΩ: LEVEL2 125 mV/47 kΩ: LEVEL3
Output terminals	Speaker × 2: 20 W/4 Ω Impedance: 4 Ω – 16 Ω Headphones (× 1): 25 mW/32 Ω Impedance: 16 Ω – 1 kΩ LINE OUT × 1: 1 V/47 kΩ

Tuner

Tuner Frequency	FM: 87.50 MHz – 108.00 MHz AM: 531 kHz – 1 710 kHz (9 kHz spacing) 530 kHz – 1 710 kHz (10 kHz spacing)
-----------------	---

General

Power requirement	AC 240 V ~, 50 Hz
Power consumption	55 W (at operation) 8 W (Touch illumination ON/QP Link ON) 1.1 W (Touch illumination OFF/QP Link OFF)

Dimensions 165 mm (W) × 204 mm (H) × 339.5 mm (D)

Mass (approx.) 4.1 kg

CD player

Playable discs Audio CDs and MP3

■ Speaker section (SP-UXQX1W/SP-UXQX1A)

System 2-way bass reflex type

Speakers Woofer: 11 cm cone speaker × 1
Tweeter: 4 cm cone speaker × 1

Power handling capacity 20 W

Impedance 4 Ω

Frequency range 56 Hz – 40 kHz

Sound pressure level 84 dB/W·m

Dimensions 135 mm (W) × 200.5 mm (H) × 215 mm (D)

Mass (approx.) 1.9 kg each

■ Micro component system (UX-QX3W/UX-QX3A)

Dimensions 435 mm (W) × 204 mm (H) × 339.5 mm (D)

Mass (approx.) 7.9 kg

JVC