



**PTZ IP DOME CAMERA  
OUTDOOR PTZ IP DOME CAMERA**

**VN-V685U  
VN-V686BU  
VN-V686WPBU**

**INSTRUCTIONS**



VN-V685U/  
VN-V686BU

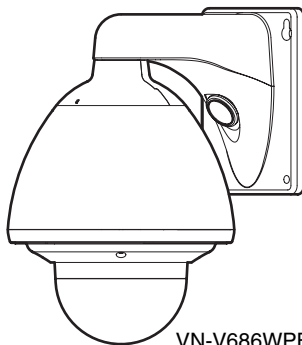

VN-V686WPBU

Thank you for purchasing this product.  
Before beginning to operate this unit, please read  
the instruction manual carefully in order to make  
sure that the best possible performance is  
obtained.

**For Customer Use:**

Enter below the Serial No. which is located on the  
body.

Retain this information for future reference.

Model No. VN-V685U/VN-V686BU/VN-V686WPBU

Serial No. \_\_\_\_\_

## Safety Precautions

### Information for Users on Disposal of Old Equipment

#### [European Union]



This symbol indicates that the electrical and electronic equipment should not be disposed as general household waste at its end-of-life. Instead, the product should be handed over to the applicable collection point for the recycling of electrical and electronic equipment for proper treatment, recovery and recycling in accordance with your national legislation.

By disposing of this product correctly, you will help to conserve natural resources and will help prevent potential negative effects on the environment and human health which could otherwise be caused by inappropriate waste handling of this product. For more information about collection point and recycling of this product, please contact your local municipal office, your household waste disposal service or the shop where you purchased the product.

Penalties may be applicable for incorrect disposal of this waste, in accordance with national legislation.

#### (Business users)

If you wish to dispose of this product, please visit our web page [www.jvc-europe.com](http://www.jvc-europe.com) to obtain information about the take-back of the product.

#### [Other Countries outside the European Union]

If you wish to dispose of this product, please do so in accordance with applicable national legislation or other rules in your country for the treatment of old electrical and electronic equipment.

#### Attention:

This symbol is only valid in the European Union.

### FOR USA AND CANADA



#### CAUTION

RISK OF ELECTRIC SHOCK  
DO NOT OPEN



CAUTION: TO REDUCE THE RISK OF ELECTRIC SHOCK, DO NOT REMOVE COVER (OR BACK). NO USER-SERVICEABLE PARTS INSIDE. REFER SERVICING TO QUALIFIED SERVICE PERSONNEL.



The lightning flash with arrowhead symbol, within an equilateral triangle is intended to alert the user to the presence of uninsulated "dangerous voltage" within the product's enclosure that may be of sufficient magnitude to constitute a risk of electric shock to persons.



The exclamation point within an equilateral triangle is intended to alert the user to the presence of important operating and maintenance (servicing) instructions in the literature accompanying the appliance.

### Information for USA

This device complies with part 15 of the FCC Rules. Changes or modifications not approved by JVC could void the user's authority to operate the equipment.

This equipment has been tested and found to comply with the limits for a Class A digital device, pursuant to Part 15 of the FCC Rules. These limits are designed to provide reasonable protection against harmful interference when the equipment is operated in a commercial environment. This equipment generates, uses, and can radiate radio frequency energy and, if not installed and used in accordance with the instruction manual, may cause harmful interference to radio communications. Operation of this equipment in a residential area is likely to cause harmful interference in which case the user will be required to correct the interference at his own expense.

This device complies with Part 15 of the FCC Rules. Operation is subject to the following two conditions: (1) This device may not cause harmful interference, and (2) this device must accept any interference received, including interference that may cause undesired operation.

Due to design modifications, data given in this instruction book are subject to possible change without prior notice.

**WARNING:**  
**TO REDUCE THE RISK OF FIRE OR ELECTRIC SHOCK, DO NOT EXPOSE THIS APPLIANCE TO RAIN OR MOISTURE.**

**AVERTISSEMENT:**  
**POUR EVITER LES RISQUES D'INCENDIE OU D'ELECTROCUTION, NE PAS EXPOSER L'APPAREIL A L'HUMIDITE OU A LA PLUIE.**

**INFORMATION (FOR CANADA)**  
**RENSEIGNEMENT (POUR CANADA)**

This Class A digital apparatus complies with Canadian ICES-003.

Cet appareil numérique de la Class A est conforme à la norme NMB-003 du Canada.

**WARNING (FOR EUROPE):**

This is a Class A product. In a domestic environment this product may cause radio interference in which case the user may be required to take adequate measures.

**Dear Customer**

This apparatus is in conformance with the valid European directives and standards regarding electromagnetic compatibility and electrical safety.

European representative of Victor Company of Japan, Limited is :

JVC Technical Services Europe GmbH  
Postfach 10 05 04  
61145 Friedberg  
Germany

Sehr geehrter Kunde, sehr geehrte Kundin, dieses Gerät stimmt mit den gültigen europäischen Richtlinien und Normen bezüglich elektromagnetischer Verträglichkeit und elektrischer Sicherheit überein.

Die europäische Vertretung für die Victor Company of Japan, Limited ist:

JVC Technical Services Europe GmbH  
Postfach 10 05 04  
61145 Friedberg  
Deutschland

- This installation should be made by a qualified service person and should conform to all local codes.
- This installation shall be in accordance with the National Electrical Code, ANSI/NFPA 70.
- The unit is to be powered by an AC 24 V power supply.  
The AC 24 V power supply should conform to the following: Class 2 only (For USA), Isolated power supply only (For Europe and other).
- Any Mention in this manual of Alarm inputs/ outputs have not been evaluated by UL to be used for Burglar Alarm Functionality.

**FOR USA-California Only**

This product contains a CR Coin Cell Lithium Battery which contains Perchlorate Material - special handling may apply.

See

[www.dtsc.ca.gov/hazardouswaste/perchlorate](http://www.dtsc.ca.gov/hazardouswaste/perchlorate)

## Getting Started

These are general IMPORTANT SAFEGUARDS and certain items may not apply to all appliances.

### IMPORTANT SAFEGUARDS

1. Read all of these instructions.
2. Save these instructions for later use.
3. All warnings on the product and in the operating instructions should be adhered to.
4. Unplug this appliance system from the wall outlet before cleaning. Do not use liquid cleaners or aerosol cleaners. Use a damp cloth for cleaning.
5. Do not use attachments not recommended by the appliance manufacturer as they may cause hazards.
6. Do not use this appliance near water - for example, near a bathtub, washbowl, kitchen sink, or laundry tub, in a wet basement, or near a swimming pool, etc.
7. Do not place this appliance on an unstable cart, stand, or table. The appliance may fall, causing serious injury to a child or adult, and serious damage to the appliance. Use only with a cart or stand recommended by the manufacturer, or sold with the appliance. Wall or shelf mounting should follow the manufacturer's instructions, and should use a mounting kit approved by the manufacturer. An appliance and cart combination should be moved with care. Quick stops, excessive force, and uneven surfaces may cause the appliance and cart combination to overturn.
8. Slots and openings in the cabinet and the back or bottom are provided for ventilation, and to insure reliable operation of the appliance and to protect it from overheating, these openings must not be blocked or covered. The openings should never be blocked by placing the appliance on a bed, sofa, rug, or other similar surface. This appliance should never be placed near or over a radiator or heat register. This appliance should not be placed in a built-in installation such as a bookcase unless proper ventilation is provided.
9. This appliance should be operated only from the type of power source indicated on the marking label. If you are not sure of the type of power supplied to your home, consult your dealer or local power company. For appliance designed to operate from battery power, refer to the operating instructions.
10. For added protection for this product during a lightning storm, or when it is left unattended and unused for long periods of time, unplug it from the wall outlet and disconnect the antenna or cable system. This will prevent damage to the product due to lightning and power-line surges.
11. Do not allow anything to rest on the power cord. Do not locate this appliance where the cord will be abused by persons walking on it.
12. Follow all warnings and instructions marked on the appliance.
13. Do not overload wall outlets and extension cords as this can result in fire or electric shock.
14. Never push objects of any kind into this appliance through cabinet slots as they may touch dangerous voltage points or short out parts that could result in a fire or electric shock. Never spill liquid of any kind on the appliance.
15. Do not attempt to service this appliance yourself as opening or removing covers may expose you to dangerous voltage or other hazards. Refer all servicing to qualified service personnel.
16. Unplug this appliance from the wall outlet and refer servicing to qualified service personnel under the following conditions:
  - a. When the power cord or plug is damaged or frayed.
  - b. If liquid has been spilled into the appliance.
  - c. If the appliance has been exposed to rain or water.
  - d. If the appliance does not operate normally by following the operating instructions. Adjust only those controls that are covered by the operating instructions as improper adjustment of other controls may result in damage and will often require extensive work by a qualified technician to restore the appliance to normal operation.
  - e. If the appliance has been dropped or the cabinet has been damaged.
  - f. When the appliance exhibits a distinct change in performance - this indicates a need for service.
17. When replacement parts are required, be sure the service technician has used replacement parts specified by the manufacturer that have the same characteristics as the original part. Unauthorized substitutions may result in fire, electric shock, or other hazards.
18. Upon completion of any service or repairs to this appliance, ask the service technician to perform routine safety checks to determine that the appliance is in safe operating condition.

PORTABLE CART WARNING  
(symbol provided by RETAC)



S3125A



---

## Contents

---

### Getting Started

Safety Precautions .....	2
Contents .....	5
Main Features .....	6
Safety precautions .....	8
Operating Environment .....	8
Precautions .....	9
Name and Function of Parts .....	13
VN-V685U/VN-V686BU .....	13
VN-V686WPBU .....	15
Features .....	16

---

### Connection/Installation (VN-V685U/VN-V686BU)

Mounting the Camera .....	18
Power Connection .....	23
LAN Cable Connection .....	24
Connecting the alarm signal terminal .....	25

---

### Connection/Installation (VN-V686WPBU)

Mounting the Camera .....	26
Power Connection .....	30
LAN Cable Connection .....	31
Connecting the alarm signal cable .....	32

---

### Network Setting

Network Requirements .....	33
IP Address Settings .....	36
IP address setting procedure .....	36
IP address setting at the computer .....	37
Internet Explorer settings .....	38
Connecting the camera to the computer .....	40
IP address setting for the camera .....	42
Enter user name and password .....	44

---

### Setting Using Internet Explorer

Setting .....	46
How to open the setting page .....	46
Basic Settings1 .....	47
Basic Settings2 .....	48
Camera Page .....	51
Encoding Page .....	56
Alarm Page .....	58
Alarm Environment Page .....	62
PTZ Page .....	66
Auto Patrol Page .....	72
Privacy Mask Page .....	74
Motion Detection Page .....	76
Network Basic Page .....	78
Network Details Page .....	80
Protocol Page .....	81
Streaming Page .....	82
Access Restrictions Page .....	84
Time Page .....	86
Password Page .....	87
Maintenance Page .....	88
List of Factory Settings of Each Page .....	90
Miscellaneous page .....	94
Operation Page .....	95
Settings Page .....	96
Position List Page .....	99
Patrol Settings Page .....	100

---

### Operation

Built-in Viewer .....	101
Screen Configuration of Built-in Viewer .....	102
Image quality setting .....	104
PTZ Setting .....	106
PTZ Control .....	112
JPEG Viewer Settings .....	117
MPEG4 Viewer Settings .....	119
Operator Password .....	121
Exiting the Viewer .....	122

---

### Others

Troubleshooting .....	123
Specifications .....	126

### Main Features

#### Support for PoE (Power over Ethernet)

This camera supports PoE (IEEE802.3af) and enables power supply through a LAN cable.

- \* Connect to AC 24 V when using the heater. (VN-V686WPBU only)

#### Dual Stream Full Frame Rate Transmission

Dual stream (JPEG, MPEG4) data transmission is possible in VGA size at a rate of 30 fps.

#### Realizing a High Picture Quality

This product uses high resolution 380,000 pixels CCD and a new digital image processing IC to achieve high resolution and image quality.

#### Progressive Output

This function realizes high picture quality of moving objects by fixing combing noise on the contour of the objects.

#### Long Magnification Zoom Lens

The optical 36 times (VN-V686BU/VN-V686WPBU) and 27 times (VN-V685U) long magnification lenses allow you to conduct detailed monitoring. The high power and large focal ratio F1.6 (WIDE edge) and bright zoom lens realize 1.0 lux (AGC Super, 50 %) high sensitivity during color mode.

#### Equipped with high precision high speed rotation platform

The newly developed direct drive rotation platform rotates at a high speed of 400°/s both horizontally and vertically, thus allowing the camera to move to the preset positions quickly. As it does not have a slowdown mechanism, it is very durable, has a high stopping accuracy and can rotate smoothly even at low speed.

#### Image Stabilizer

This function detects camera shaking and reduces image shaking.

#### Automatic Tracking function

This product is equipped with a function that easily tracks moving objects when home position is displayed.

#### Intelligent Tracking Feature

This feature enables you to track color information of the object that you selected by clicking. Linking the zoom feature enables tracking while automatically adjusting to the optimal magnification ratio.

#### Day/Night surveillance

This product is equipped with infrared filter mechanism for day/night surveillance. During low illuminance such as nighttime, switching out the infrared filter will switch the product to high sensitivity mode (B&W).

#### Privacy Mask function

This function allows you to blank out areas that you do not wish to display in the location to be recorded.

#### Motion Detection Feature

This feature enables output of an alarm upon detection of motion in the video image within preset area. Pre-/Post-recorded JPEG image files can be sent to FTP server by the alarm.

#### Support for Multicast

This product supports multicast, which enables transmission of image data to multiple computers on the network without lowering the frame rate.

#### Support for IPv6 dual stack

This camera supports IPv6 and enables transition from IPv4.

#### HTTP-based API

This product comes with HTTP-based API. This feature enables you to perform setting and control via the network.

#### Built-in Integrated Viewer Software

This product comes with a built-in integrated viewer that enables you to monitor camera images (JPEG or MPEG4) on the computer. It can also be used to configure the camera settings and control the camera. It also employs a new GUI for greater user-friendliness.

#### Waterproof and Weatherproof Chassis (VN-V686WPBU)

This camera is equipped with a dust-proof and drip-proof mechanism that prevents it from being subject to rain, and therefore can be installed outdoors. (IP66 specification)

- \* However, VN-V685U/VN-V686BU can only be used indoors. Do not use them in an outdoor environment or expose them to moisture.

**This manual contains the detailed instructions for using this unit.**

**Please refer to [READ ME FIRST] for description on the general usage of this unit.**

**For the latest information, please refer to the "Readme" file in the CD-ROM supplied with this product.**

- The supplied CD-ROM includes INSTRUCTIONS (this manual) (pdf), [API Guide] (pdf), [VSIP Guide] (pdf) and [Search tool].

- Before starting an important recording, be sure to perform a test recording in order to confirm that a normal recording is possible.
- We do not accept liability for the loss of a recording in the case of it becoming impossible to record due to a problem in the video camera, VTR, hard disk recorder or video tape.
- The Automatic Tracking, Intelligent Tracking, and Motion Detection features are simple functions and cannot be used as a substitute for a security alarm. JVC shall not be liable for any inconveniences or damages caused in the event of false detection or when these functions cannot be detected. We shall not be liable for any inconveniences or damages caused as a result of operational failure for alarm input/output.

## How to Read this Manual

### ■ Symbols used in this manual

- Note** :States precautions to be taken during operation.
- Memo** :States restrictions on the functions or use of this equipment. For reference purposes.
-  :Indicates the page numbers or items to refer to.

### ■ Contents of this manual

- JVC holds the copyright to this manual. Any part or all of this manual may not be reproduced without prior consent from the company.
- Windows is a registered trademark of Microsoft Corporation in the U.S.
- Product names of other companies described in this manual are trademarks or registered trademarks of the respective companies. Symbols such as ™, ® and © are omitted in this manual.
- Design, specifications and other contents described in this manual are subject to change for improvements without prior notice.
- Screen displays in this manual may differ from the actual ones.

## Safety precautions

### Mounting to a firm place

As the unit rotates at high speed, mount it on a firm place with sufficient strength to support the vibration and weight of the unit

Mass:Approx. 1.9 kg (VN-V685U/VN-V686BU)

:Approx. 5.5 kg (VN-V686WPBU)

If the strength is weak, the vibration will cause fuzzy images on the monitor screen. In the worst scenario, the camera may even fall off and hit somebody, resulting in serious accidents.

### Mounting the camera correctly with the designated clamping brackets

Always use the designated clamping brackets. Be sure to connect the fall prevention wire and tighten the fixing screws or nuts securely.

### Using the correct power and voltage

The rated power of this product is AC 24 V, 50 Hz/60 Hz. Supplying a power beyond the rated value may result in failures and in the worst scenario, smoking and fire.

This unit is able to divert lightning conduction to itself and the connecting cables to a certain extent but this is not 100 % guaranteed. For installation locations that are likely to suffer lightning strikes, be sure to take appropriate measures such as adding arresstor to the connecting cables.

Consult your dealer as special technique is required when installing this product. Ensure that the fixing screws or nuts are tightened securely, otherwise, the unit may fall off.

### Inspect the unit regularly.

Screws may be loosened due to vibration or deterioration of the mounting section. Perform regular inspections for loosened screws and check whether there is any danger of the unit falling off.

Do not hang on this product, shake it, or hang objects over it. Applying an excessive load may cause the product to fall off and result in accidents.

Do not modify this product. It may result in accidents.

## Operating Environment

### Recommended Computer Specifications

OS : Windows XP (Professional or Home Edition) (SP2)  
:Windows Vista Business (SP1)

CPU : Pentium4 2 GHz or higher

Memory capacity: 1 GB and above

Free hard disk space

:512 MB or more

Display and video card

:1024 × 768 pixels or higher, True Color (24 bits or 32 bits)  
VRAM 8 MB or more (256 MB and above recommended)

Web browser: Internet Explorer

XP : Version 6.0

Vista : Version 7.0

### LAN Environment

- 10BASE-T/100BASE-TX network interconnected using devices such as an IEEE802.3-compliant switching hub.
- IEEE802.3af-compliant switching hub when PoE is used
- IGMPv2-compliant network when multicast is in use.

### Memo:

- The above PC specifications are guides for smooth use of the applications, and not a guarantee of their operation.
- Depending on the condition of use, applications may not run smoothly even when the user's computer meets the specification requirements.
- The following may occur if the performance of the computer is insufficient.
  - Playback frame rate for JPEG images may drop
  - Delay in the MPEG4 playback images may occur, and playback is interrupted
- To use MPEG4 images on the integrated viewer, install the open source codec "ffdshow". You can download "ffdshow" from the Internet.

# Precautions

## Storage and operating environment

- VN-V685U/VN-V686BU is an indoor camera. It cannot be used outdoors.
- VN-V685U/VN-V686BU is a pendant mount camera. Be sure to place the camera head horizontally. The product will not work properly if it is tilted.
- VN-V686WPBU is specially designed to be mounted on walls. Be sure to place the camera head horizontally. The product will not work properly if it is tilted.
- Do not store in the following environments. It might result in malfunctions or failure.
  - Locations beyond the allowable operating humidity range of 20 %RH to 90 %RH. (condensation is not allowed)
  - Near equipment that emits strong magnetic fields, such as transformers or motors.
  - Near equipment that emits radio waves, such as transceivers and mobile phones.
  - Locations with excessive dust and sand.
  - Locations that are subject to vibration such as inside the car or ship.
  - Locations prone to moisture such as window side.
  - Locations subject to steam or oil, such as kitchens.
  - Special environment, such as those with combustible atmosphere
  - Locations that are subjected to radiation, X-rays, salt attack or corrosive gases.
  - Locations where medicine is used such as pools.
  - Hot or cold places that are beyond the allowable operating temperature range

■ Allowable operating temperature

VN-V685U/VN-V686BU	-10°C to 50°C
VN-V686WPBU	
AC 24 V power supply	-40°C to 50°C
PoE power supply	-10°C to 50°C

- When power is supplied to VN-V686WPBU using PoE, the heater will not work. Use an AC 24 V power supply when using the camera in an environment under -10°C.
- When using VN-V686WPBU in a low temperature environment (-40°C to -20°C), images may not be displayed for up to two hours until the interior is warmed up by the built-in heater. It is therefore recommended that power be supplied to the camera at all times when the surrounding temperature is low. Inadequate heat ventilation may result in malfunction

of this product. Be sure not to block vents around the product. This product discharges heat from the surface of the main unit.

- Do not install it at locations directly subjected to cold air such as near the vents of air-conditioners or at locations with high temperature. Condensation may occur inside the dome cover.
- Use of this product and cables connected to this product at locations where strong electric waves and magnetic waves are generated (e.g., near radio, TV, transformer, monitor, etc.) may cause noise interferences in the images or changes in the color.

## Others

- Do not subject the lens to strong light source such as sun rays. This may cause the equipment to malfunction.
- This camera comes with a built-in AGC circuit. The sensitivity increases automatically at a dark place and the screen may appear grainy. This is not a malfunction.
- While AGC is activated, if a transceiver which causes strong electromagnetic wave is used near the camera, the picture may suffer from beat. Please use the camera more than three meters away from such transceivers.
- When automatic iris is selected, the Iris Control button may not work depending on the brightness of the screen (when the amount of light is not sufficient). In this case, set the iris to Manual.
- When automatic iris is selected and AGC is ON, even if the iris setting can be changed with the Iris Control button, the Sense Up function will be enabled and the brightness of the screen may not change. In this case, set AGC to OFF or set the iris to Manual.
- When this camera is used in the White Balance "ATW-Narrow", "ATW-Wide" (automatic adjustment) mode, the color tone may differ slightly from the actual color due to the principle of the automatic tracking white balance circuit. This is not a malfunction.
- If a high brightness object (such as a lamp) is shot, the image on the screen may have white vertical tailings. This phenomenon (smear) is characteristic of solid-state image sensors and is not a malfunction.
- Do not touch the dome cover with your hands. Dirty covers will cause image deterioration.
- Do not subject the dome cover to strong impact. It may result in damage and water seepage.
- The dome cover may fog up due to the drastic change of temperature when humidity is high.
- Do not connect an AC 24 V cable to AC 110 V/AC 230 V power supply. The camera internal circuit will be damaged. Should that happens, do not use the camera. Bring it to your nearest JVC dealer for repair. (charged separately)
- To supply AC 24 V, use an AC 24 V supplying power unit that is insulated from AC 110 V/AC 230 V line.

### Precautions (continued)

#### Others (continued)

- Depending on the stop position and rotation speed of the horizontal/vertical rotation platform, the running sound of the rotation platform's motor may be heard, but this is not a malfunction.
- When using multicast, make use of a IGMPv2-compliant network switch.
- Some hubs/switches of products that are equipped with intelligent features may include a broadcast/multicast suppression function. Viewing of multicast images on this product may fail if this function is enabled.
- The electronic shutter of this product is set to 1/60 by default. For regions with a commercial power supply frequency of 50 Hz, switch to the 1/100 during use under fluorescent lights (excluding inverter lighting equipment) to prevent flickers.
- When the B&W mode is set to "Auto", the image turns black-and-white in a dark location. As the sensitivity level is increased in this case, the screen may appear grainy and more white spots may appear. When switching between color and black-and-white images, the brighter area on the screen is emphasized, which may reduce the visibility. However, this is not a malfunction.
- If the power supply voltage is momentarily cut off or reduced due to lightning or turning on of the air conditioner's power, the image may be disrupted or noise interference may occur.
- As the dome cover is of a semiglobular shape, image distortion will occur at the hemispherical edge. When the hemispherical edge of this unit is masked and horizontal level is shot in a tilt direction, the hemispherical edge will enter the field angle. This may cause the upper edge of the screen to become black and the focus unclear. In this case, you can avoid shooting the above area by using the tilt limit settings (☞ Page 70).
- When shooting objects with a luminance difference or near a light source, ghost may occur on the screen. This is a feature of the dome cover and the built-in lens, and is not a malfunction.
- In particular, manual and auto pan operation near the TELE edge (telephoto side) may cause the screen to vibrate (unsmooth rotation). This is a feature of the motor and is not a malfunction.
- As long magnification lens is used in this product, the focus may be unclear due to temperature changes but this is not a malfunction.
- Preset the focus under an environment with a temperature closest to that in your actual usage. If the temperature change is large and the focus becomes unclear, preset the focus again before using the product.

- If you sense that the focus has become unclear due to temperature changes, use the Auto Focus(AF) function or reset the focus manually.

#### Transporting the unit

- Remove the connecting cables when transporting the unit.
- When transporting the unit, turn off the power of the system.
- Pack the unit with cushioning material so as to avoid shock when transporting.
- Handle the unit with care and do not subject it to vibration or shock.

#### Copyright Protection

- With the exception of the user being the copyright holder or when permission such as for duplication has been granted by the copyright holder, permission is required in principle for the duplication, modification, or transmission of copyrighted video and audio data. Unauthorized duplication, modification, or transmission of copyrighted material may constitute a copyright infringement, and the user may be liable to compensate for any damages. When using copyrighted video/audio data, be sure to check the license agreement of the copyrighted material thoroughly. When rights or rights holders are involved with regard to the targeted duplicating subject, permission may be required for shooting or using (processing) it. Be sure to check the licensing conditions thoroughly.

#### Maintenance

- Turn off the power before performing maintenance.
- Wipe using a soft cloth. Wiping with thinner or benzene may melt or tarnish its surface. For tough stains, wipe using a cloth that is dipped into a neutral detergent diluted with water, followed by wiping with a dry cloth.
- When the same position is monitored for 24 hours continuously over a long period, the increased contact resistance on the horizontal rotation section may cause noise interferences in the images and operation from the computer may become unstable. As such, this product is equipped with an auto cleaning function that performs cleaning once a week.

#### Saving Energy

- If the camera is not to be used for a long time, turn off the power of the system for safety and energy conservation reasons.

## Disclaimer

- The Automatic Tracking, Intelligent Tracking, and Motion Detection features are not features to prevent theft or fire. Our company shall not be liable for any inconveniences or failures that occur.
- We shall not be responsible for any inconveniences or disturbances caused in the event of privacy invasion as a result of camera footages of this product.

## Transportation

- Do not throw away the original box of the unit. Keep it and use it for transporting the unit in future.
- As the camera unit is of an easily rotatable structure, secure the camera unit inside the dome cover such that it does not rotate before transporting. Otherwise, an error may occur during camera operation.
  - ① Face the heat release vents upward and secure the lens section with tape.
  - ② Insert cushioning material wrapped with air caps (approx. 50 mm x 200 mm) at two opposite sides of the camera.
- When attaching the ceiling clamping bracket to the camera unit before transporting, pull out the tip of the fall prevention wire to prevent it from being caught between the camera and clamping bracket. Otherwise, it may be difficult to detach the bracket from the camera. (VN-V685U/VN-V686BU)

■ VN-V685U/VN-V686BU      Cushioning material

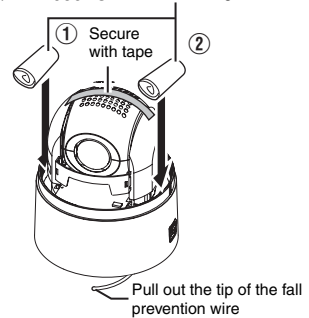

■ VN-V686WPBU

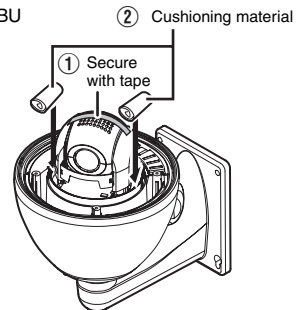

### Precautions (continued)

#### ■ Consumable parts

The following are consumable parts. They must be replaced once they reach their lifetime. The lifetime is only an estimation and differs according to the usage environment and conditions. Replacement of consumable parts is chargeable within the guarantee period.

- Zoom lens assembly
  - Zoom operation ..... Approx. 2 million operations
  - Focus operation..... Approx. 4 million operations
- Slip ring ..... Approx. 5 million operations
- Cooling fan ..... Approx. 50,000 hours
- Heater relay(VN-V686WPBU)..... Approx. 100,000 times
- Heater fan(VN-V686WPBU) ..... Approx. 50,000 hours

#### ■ Auto Focus

This unit is equipped with Auto Focus functions. However, depending on the object and the camera setting, it might be out of focus. In this case, please adjust the focus manually.

- Objects which are difficult to be focused automatically
  - When the brightness of the image plane is extremely high (bright)
  - When the brightness of the image plane is extremely low (dim)
  - When the brightness of the image plane is constantly changing (for example, a blinking light)
  - When there is almost no contrast
  - When there are repetitive vertical striped patterns on the image plane
- Auto Focus is difficult to set under the following conditions
  - When sensitivity is increased with AGC and the screen is grainy
  - When there is less movement on the screen due to the Sense Up function.
- When there is no clear contour in electronic zoom

#### ■ Zoom Operation

The following phenomena are the results of the built-in lens performance and are not malfunctions.

- When manual operation or preset is selected, focus moves slightly after the zoom operation has stopped near the TELE edge.
- Manual zoom operation is not smooth.
- When Preset is selected, the camera becomes out of focus for an instant during zooming.

#### ■ Preset Positions

The total number of preset positions that can be set in this unit is 100, including the home position and 99 preset positions.



# Name and Function of Parts

## VN-V685U/VN-V686BU

### ■ Ceiling mount section

#### Terminal

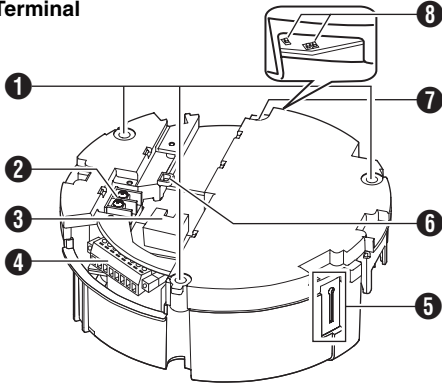

#### ❶ Fixing holes (x3)

This hole is for mounting the ceiling clamping bracket to the ceiling or the ceiling recessed bracket (WB-S685: Sold separately).

#### ❷ [AC24V INPUT] AC 24 V Input terminal

This connects the camera to AC 24 V power.

#### ❸ [10BASE-T/100BASE-TX] LAN cable connection terminal

This connects the unit to the network.

It supports PoE (IEEE802.3af) and enables you to use this camera without having to connect to a power supply using a power cord.

PoE: class0 (☞ Page 24)

#### ❹ Alarm input/Alarm output terminal

This terminal is for alarm input/alarm output.

(☞ Page 25)

Pin number	Signal Name
1	Input 1
2	Input 1 COM
3	Input 2
4	Input 2 COM
5	Output 1
6	Output 1 COM
7	Output 2
8	Output 2 COM

#### Reverse side

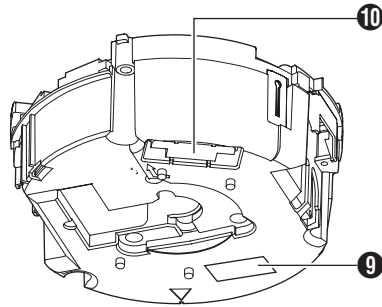

#### ❺ Fall prevention wire fixing bracket

This attaches to the fall prevention wire ❿ of the camera.

#### ❻ Wire clamp fixing hole

This is used to bundle wires. (☞ Page 19)

#### ❼ Fall prevention wire mounting hole

Mount wires from the ceiling slab or channel to this hole to prevent the camera from falling.

#### ❽ Power indicator

The indicator lights up in green when AC 24 V power/ PoE power is turned on.

#### ❾ [Mac address] indication

The MAC address is a unique physical address of the product. This address cannot be altered.

#### ❿ Camera connection terminal (female)

This connects to the connection terminal (male) of the camera.

### Name and Function of Parts (continued)

#### VN-V685U/VN-V686BU (continued)

##### ■ Camera

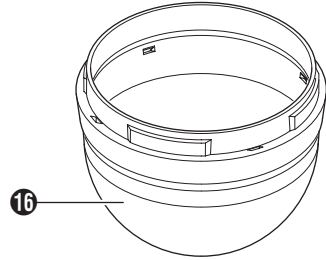
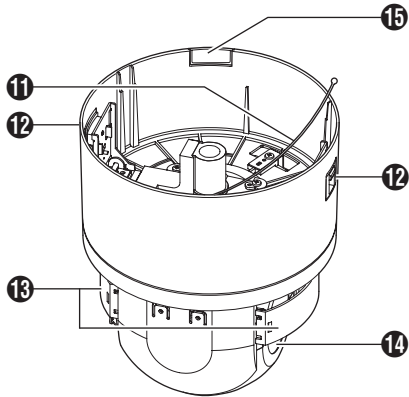

##### 11 Fall Prevention Wire

This is fixed to the fall prevention wire fixing bracket 5 of the ceiling clamping bracket.

##### 12 Camera lock knob (x2)

This mounts the camera on the ceiling and secures it so that it does not fall.

##### 13 Front Mask

##### 14 Lens

Lens cannot be replaced.

##### 15 Cable cover

To pull the cables from the side and mount the camera, remove the cover. (☞ Page 20)

##### 16 Dome Cover

The dome cover is a delicate object. Handle it with care.

##### Note:

Do not peel off the protective sheet which is attached at shipment, until the dome cover is mounted on the main unit. (☞ Page 21)

## VN-V686WPBU

### ■ Front side

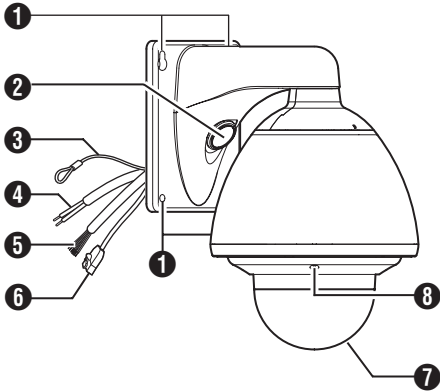

#### ❶ Camera securing hole (4 locations)

This hole is used for mounting the camera on the wall.

#### ❷ Cable connecting hole, cap

Remove the cap and pull out the cables from this hole for connection. (☞ Page 27)

#### ❸ Fall Prevention Wire

Connects the camera to the wall. Secure the camera tightly to the anchor bolts used to mount the fall prevention wire on the wall. (☞ Page 28)

#### ❹ AC 24 V Power Cable

This connects the camera to AC 24 V power. (☞ Page 30)

#### ❺ Alarm Input/Alarm Output Cable (x8)

This cable is for alarm input and alarm output. (☞ Page 25)

Cable color	Signal Name
Brown	Input 1
Red	Input 1 COM
Orange	Input 2
Yellow	Input 2 COM
Green	Output 1
Blue	Output 1 COM
Purple	Output 2
Gray	Output 2 COM

### ■ Inner structure of the camera

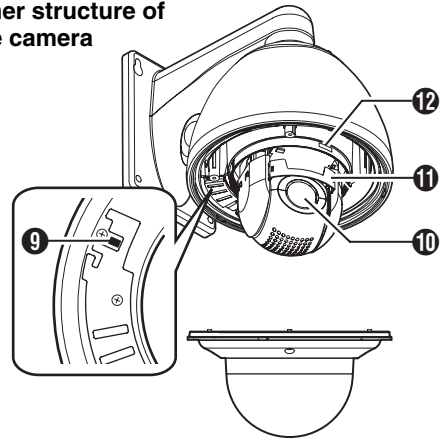

#### ❻ LAN Cable

This connects the unit to the network. (☞ Page 24)

#### ❼ Dome Cover

The dome cover is a delicate object. Handle it with care.

#### Note:

- It is covered with a protective sheet during shipment. Do not remove this sheet until installation is complete.

#### ❽ Dome Cover Fixing Screws (x4)

#### ❾ Heater ON/OFF Switch

This is the automatic control ON/OFF switch of the built-in heater.

The built-in heater prevents the dome cover from fogging up and snow or frost from attaching to the dome cover. When installing the heater at an unrequired location, turn off the switch of the heater. It is usually set to ON. (☞ Page 26)

#### ❿ Lens

Lens cannot be replaced.

#### ⓫ Front Mask

#### ⓬ [MAC address] indication

The MAC address is a unique physical address of the product. This address cannot be altered.

## Features

### Surveillance Using Built-in Viewer

This unit comes with a built-in ActiveX JPEG Viewer and MPEG4 Viewer. JPEG images and MPEG4 images of the camera can be monitored using the computer by installing this Built-in Viewer on the computer. JPEG images that are currently displayed can also be captured into the computer's hard disk. "Built-in Viewer" (☞Page101)

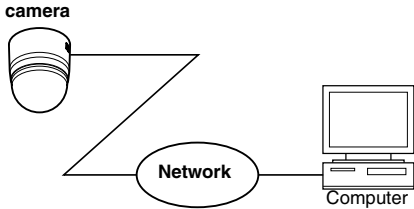

This unit accepts requests from a maximum of 20 clients.

### Monitoring via Multicast

Multicast enables monitoring of JPEG and MPEG4 images on multiple computers. "Streaming Page" (☞Page82)  
"JPEG Viewer Settings" (☞Page118)  
"MPEG4 Viewer Settings" (☞Page120)

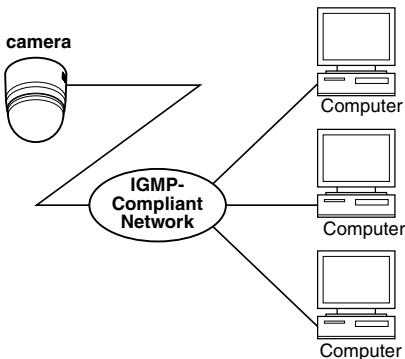

### Surveillance via Dual Stream

Simultaneous distribution of JPEG and MPEG4 images enables real-time surveillance using MPEG4 (30 fps) and recording of JPEG images at the same time. You can also lengthen the recording time by lowering the frame rate, resolution, and picture quality settings for JPEG images.

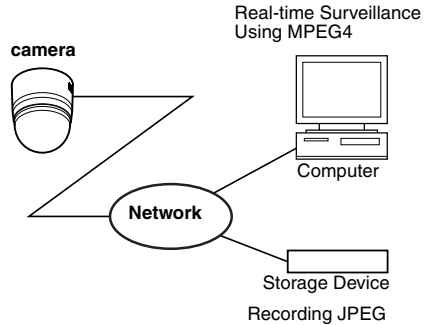

### Saving JPEG images to the FTP server at regular intervals

JPEG images may be uploaded to the FTP server at regular intervals. "FTP" (☞Page63)

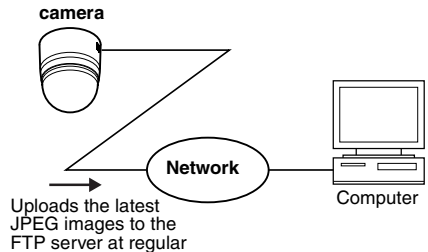

---

## Alarm

This unit comes with a motion detection feature and dual alarm input.

During motion detection or alarm input, actions such as mail delivery, message transmission via TCP/UDP, alarm output, moving to a preset position, and changing of B&W mode settings can be triggered. These actions can also be triggered by combination of two alarm inputs. Installing an FTP server enables uploading of JPEG images before and after the alarm input time (pre-/post-recording) to the server.

“Alarm Page” (☞Page58)

“JPEG Viewer Settings” (☞Page118)

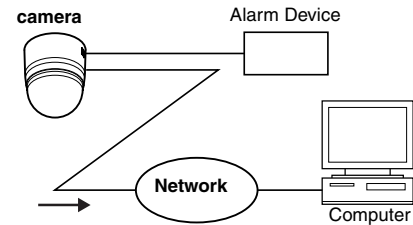

Sending JPEG images  
before and after alarm  
input to FTP

---

## Restrictions on Clients

This unit enables users to authorize or reject the acquisition of images by specific IP address.

(☞ Page 84)

---

## Control via customized application software

The following uses are also possible by developing a customized application software that supports the API of this unit.

For details, please refer to [API GUIDE] in the supplied CD-ROM.

- Monitors via the computer while at the same time records images to the HDD of the computer.
- Performs recording by changing the frame size/frame rate during alarm occurrence.
- Records the type and time of alarm occurrence on the computer.

## Mounting the Camera

### Preparation

Be sure to put on protective glasses to protect your eyes from falling objects when mounting the camera.

#### 1 Make holes on the ceiling

- Use the provided template to make a hole ( $\phi 80$  mm) for the connection cables to thread behind the ceiling.
- If necessary, also open a screw hole to mount the ceiling clamping bracket to the ceiling. In this case, align the “↑ FRONT mark” of the template in the direction where the camera faces front and open the screw hole.

#### 2 Pull the cables from the hole in the ceiling

Pull out the fall prevention wire, power cable, coaxial cable, control signal cable, alarm signal cable and provided alarm cable that were mounted to the ceiling slab from the ceiling.

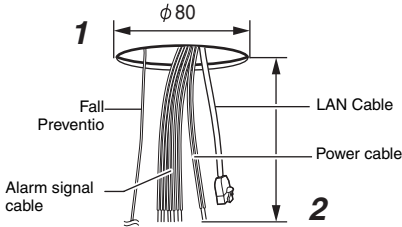

#### Note:

- Mount the fall prevention wire on a firm place with sufficient strength.

#### 3 Remove the ceiling clamping bracket from the camera unit

The ceiling clamping bracket is attached to the camera unit during packaging of the product. Before installing the camera, remove the ceiling clamping bracket from the camera unit.

- ① Check to make sure that the two camera lock knobs (left and right) are unlocked.
- If they are locked, unlock by sliding them in the direction indicated by the arrow.
- ② Press the two camera lock knobs from both the left and right sides in the direction indicated by the arrows.

- Doing so detaches the ceiling clamping bracket from the camera. Prevent the bracket from dropping such as by performing this on a table.

#### Memo:

- If the camera fixing lock knob is too stiff, push the knob hard while pressing the edge of the camera unit (▲ in the diagram) against the table you are using.
- ③ Lifting the camera unit detaches the ceiling clamping bracket. Remove by sliding it in the direction indicated by the arrows.

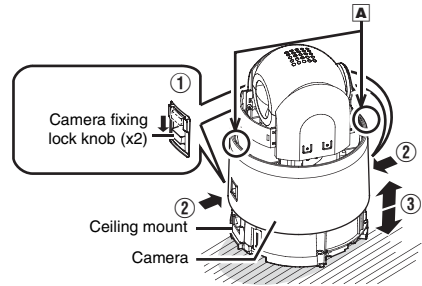

#### 4 Remove the terminal cover

Loosen two screws on the ceiling clamping bracket and remove the terminal cover.

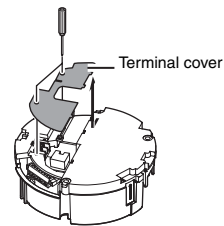

#### 5 Mount the fall prevention wire that connects the ceiling clamping bracket to the ceiling

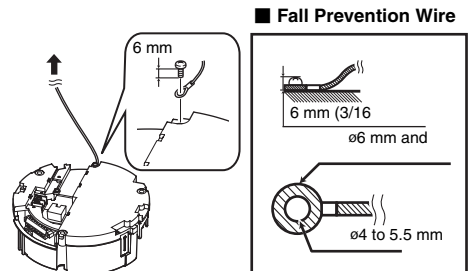

### Caution

- Take note of the length, strength, pull and material (insulation) of the fall prevention wire and use one with a wire strength of more than 20kg.
- The inner diameter of the ring section of the fall prevention wire mounted on the camera should be  $\varnothing 4$  mm to  $\varnothing 5.5$  mm and the outer diameter be  $\varnothing 9$  mm and below.
- The thickness of the screw head and the fall prevention wire (including the washer) should be 6 mm and below. If it is more than 6 mm, the screw will touch the ceiling and the camera cannot be installed horizontally.
- Use M4 fixing screws.

### Memo:

- The wire should be insulated from the ceiling structure. If the ceiling structure is metal and insulation is not provided between the camera and the ceiling structure, image noise may occur.

## 6 Connect the cable (☞ 23 to 25)

Connect cables to the terminal of the ceiling clamping bracket.

The connection cables consist of the alarm signal cable, LAN cable and AC 24 V power cable.

### ① LAN cable (☞ Page 24)

This connects the unit to the network.

### ② Power cable (☞ Page 23)

This connects to AC 24 V power.

### ③ Alarm input/output signal terminal (☞ Page 25)

This connects to devices with alarm input/output terminals.

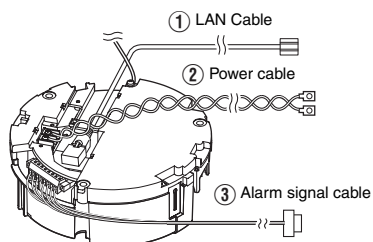

### Note:

- Do not connect an AC 24 V cable to AC 110 V power supply. The camera internal circuit will be damaged. Should that happens, do not use the camera. Bring it to your nearest JVC dealer for repair. (charged separately)
- For safety reasons, turn on the power only after all the connection is complete.
- To supply AC 24 V, use an AC 24 V supplying power unit that is insulated from AC 100 V line.

## 7 Handling cables

Thread the provided wire clamp through the wire clamp fixing hole of the ceiling clamping bracket to tie all the wires.

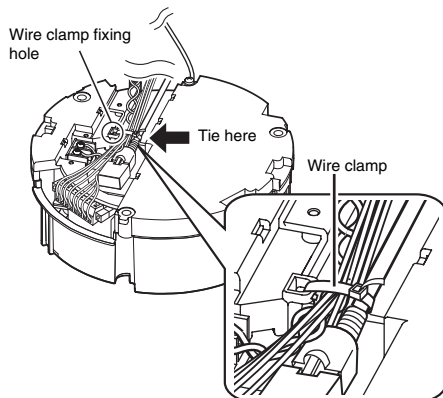

### Note:

- To prevent the cables from tangling and coming off, be sure to thread a wire clamp through the wire clamp fixing hole to tie the cables.

## Mounting the Camera (continued)

### Preparation (continued)

#### 8 Mount the terminal cover

Return the terminal cover that was removed in step 3 to its original position. The direction to pull out the cables changes according to the mounting method of the camera.

#### ■ Pulling out the cables from the side

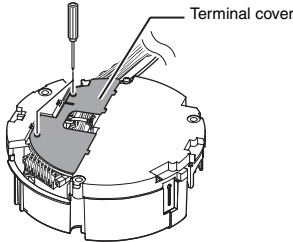

#### ■ Pulling out the cables from the top

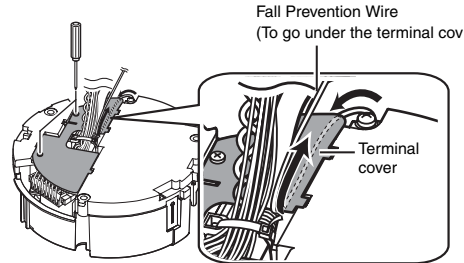

#### Note:

- Be sure to mount the terminal cover to prevent foreign objects or dust from entering.
- When pulling out the cables from the top, make the fall prevention wire go under the terminal cover and pull it out together with the other cables.
- When pulling out the cables from the side, remove the cable cover of the camera.

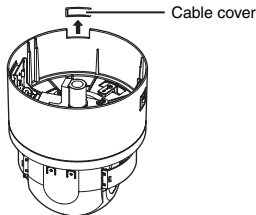

## Mounting the ceiling clamping bracket to the ceiling

### 7 Secure the ceiling clamping bracket to the ceiling

- Install such that the “↑FRONT mark” of the ceiling clamping bracket faces the front.
- Ensure that the connection cables are not caught in between and secure the ceiling clamping bracket to the ceiling with 3 screws.

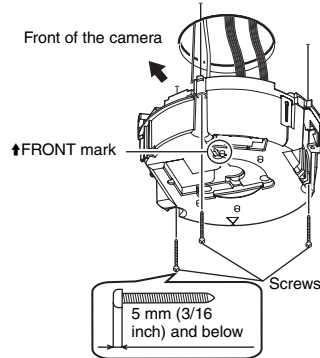

#### Note:

- Use M4 fixing screws and bolts.
- Use  $\phi 4.1$  wood screws.
- The length of the screws should be 25 mm (1 inch) and above.
- Place the product horizontally and install. The camera will not operate properly if it is slanted.
- The screw head should be 5 mm and below. If the ceiling structure is metal, image noise may occur.
- Do not use screws for which the screw head is embedded after fastening. (e.g. flat countersunk head screws). Otherwise, the insulating resin part may be damaged, thus preventing proper insulation.

#### Memo:

- Always use 3 screws and mount securely.
- Tighten the screws again during maintenance just to be safe.
- The plastic parts on the ceiling fixing holes of the ceiling clamping bracket act as an insulation between the ceiling clamping bracket and the ceiling structure. If the ceiling structure is metal and insulation is not provided between the camera and the ceiling structure, image noise may occur. Be sure to provide insulation.



---

## Mounting the camera to the ceiling

### 1 Remove the tape on the lens section

### 2 Remove the lens cap

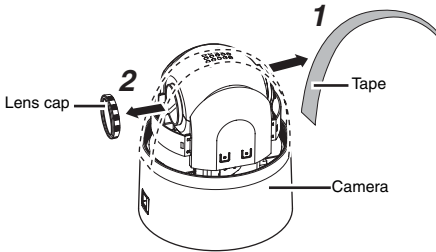

### 3 Mount the dome cover to the camera

- ① Check that the dome cover and lens are free from dirt.
- ② Turn the dome cover in a clockwise direction to mount.

#### Note:

- Be sure to turn the dome cover until it stops and tighten securely. Make sure that the dome cover is not slanted.
- Do not over-rotate the dome cover. This may damage the dome cover.

#### Memo:

- If it is difficult to screw on the dome cover, turn it in an anticlockwise direction until you hear a click sound, then turn it in a clockwise direction. It will screw on smoothly.
- 

### 4 Remove the dome cover protective sheet

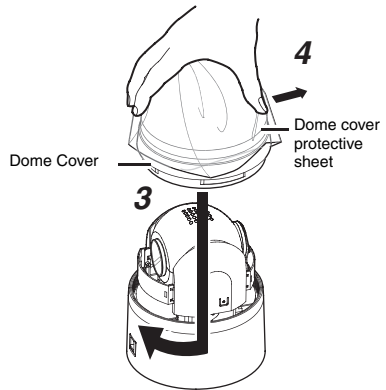

Caution
<ul style="list-style-type: none"><li>● The dome cover is an optical part. Handle with care.</li><li>● When mounting the dome cover, make sure that there is no dirt inside the cover.</li><li>● Tighten the dome cover securely.</li></ul>

## Mounting the Camera (continued)

### 5 Mount the fall prevention wire

Mount the fall prevention wire, which is attached to the camera, to the fall prevention wire fixing bracket of the ceiling clamping bracket.

#### Caution

- Be sure to connect the fall prevention wire. Otherwise, the camera may fall.
- To prevent danger, do not leave the fall prevention wire dangling by the camera.

### 6 Mount the camera

- Align the “↑” mark (blue)/(red) inside the camera with the “↑” mark (blue)/(red) on the ceiling clamping bracket.
- Insert the camera into the ceiling clamping bracket until you hear a click sound and mount it securely.

### 7 Check that the camera fixing lock knobs (x2) are sticking out.

If the camera is mounted on securely, the camera fixing lock knobs (x2) will stick out a little.

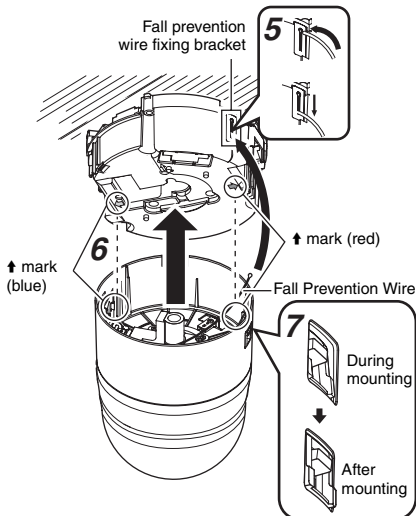

#### Note:

- Before mounting the camera, check that the camera fixing lock knobs are not locked (i.e., lock knobs are on top). The camera cannot be mounted if the lock knobs are locked.
- When pulling out the cables from the side, remove the cable cover of the camera. (☞ Page 18)

### 8 Lock

When the camera is mounted on the ceiling clamping bracket, lower the camera fixing lock knobs (x2) in the direction of the arrow and secure the camera such that it does not fall off.

### 9 Remove the safety precautions sheet on the camera

Read through details stated on the safety precautions sheet again.

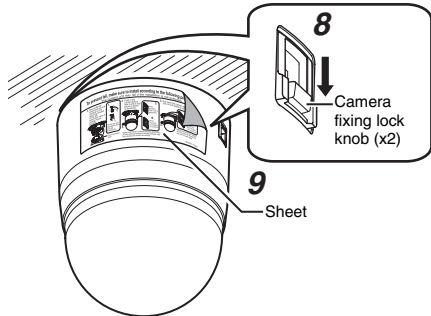

#### Caution

- Be sure to check that the camera fixing lock knobs (x2) are locked securely. Otherwise, the camera may fall.
- After mounting, check that the camera is mounted securely. Improper mounting may cause the camera to fall off.

### Removing the camera

- ① Release the lock by sliding the camera fixing lock knobs toward the ceiling.
- ② Press the two camera fixing lock knobs from both the left and right sides to remove the camera unit.
- ③ Remove the fall prevention wire by performing the mounting procedures in the reverse sequence.

## Power Connection

Power can be supplied to this camera either by connecting to an AC 24 V power supply or using PoE (Page 24).

**Note:**

- If power is supplied from both power cable and LAN cable, priority will be given to the power supply from the power cable.
- Be sure to use an AC 24 V supply that is isolated from the primary power supply circuit. Using a variable voltage power supply will cause the camera and system to malfunction or breakdown.
- The unit is to be powered by an AC 24 V power supply. The AC 24 V power supply should conform to the following: Class 2 only (For USA), Isolated power supply only (For Europe and others).

### Connecting to an AC 24 V power supply

This connects the camera to AC 24 V power.

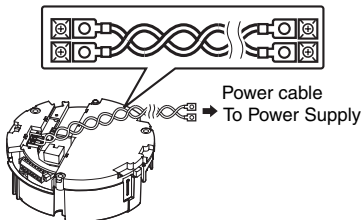

When using 2-core VVF (Vinyl-insulated vinyl-sheath cable), the connection distance is as follows: (Reference value)

Maximum connection distance	50 m	150 m	230 m	390 m
Conductor Diameter (mm)	ø1.0 and above	ø1.6 and above	ø2.0 and above	ø2.6 and above

## Warning

- The rated power of this product is AC 24 V, 50 Hz/60 Hz. Make sure to use it with the correct voltage.
- Supplying a power beyond the rated value may result in failures, smoke or fire. If the camera breaks down, turn off the power and contact our service center immediately.
- When a power beyond the rated value is supplied, the internal components may be damaged even if no abnormality is found on the appearance and operation of the camera. Please contact your nearest JVC dealer immediately for servicing (charged separately).

**Memo:**

- After DHCP timeout, all IP addresses of camera are set to 192.168.0.2 by default. If the power of multiple cameras within the same LAN environment are turned on at the same time, the IP addresses of the cameras overlap, thus preventing proper access. As such, make sure to turn on the power of the cameras one by one.
- In a system where multiple units of camera are used, turn on the power of only one unit to configure the IP address settings using the Internet Explorer. Upon doing so, turn on the power of the second unit and configure accordingly. Configure the subsequent camera settings using the same procedure.
- When there is an overlap of IP address, access to the camera may fail. When this occurs, turn on the power of only one camera unit within the same LAN environment and wait for a while (at least 10 minutes). Alternatively, turn off the power of all network devices connected to the same LAN environment, followed by turning them on again.

**Note:**

- If thin cables are used, the resistance of the cables will be high and a significant voltage drop will occur when the camera is at its maximum power consumption (when pan, tilt and zoom operates at the same time). Either use a thick cable with low resistance or place the power supply near to the camera and shorten the length of the cable to restrict the voltage drop at the rated current of the camera to below 10 %. If voltage drops during operation, the camera may experience unstable performance and be unable to call up the preset position correctly.
- Do not connect an AC 24 V cable to AC 110 V/AC 230 V power supply. The camera internal circuit will be damaged. Should that happens, do not use the camera. Bring it to your nearest JVC dealer for repair. (charged separately)
- Turn on the power only after the connection for all the devices is complete.
- After the power is turned on and activation is completed, this product will move to the home position. The default home position settings for pan, tilt, and zoom are 1.00°, 45°, and x1 respectively.

## Power Connection (continued)

### Using PoE

Supply power to the camera by connecting it to a device that supports PoE via a LAN cable.

#### What is PoE (Power over Ethernet)?

PoE is a feature that transfers data and supplies power simultaneously through a LAN cable. It enables you to operate a LAN-compatible equipment without having to connect it to a power supply using a power cord.

#### Cable to use

- Shield (STP) cable
- Length of 100 m or shorter
- Make use of a Category 5 (or higher) cable .

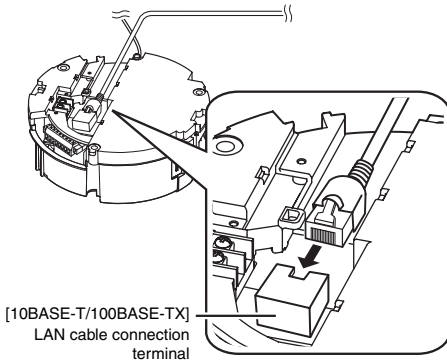

## LAN Cable Connection

Connect the camera to a hub or computer using a LAN cable.

#### Cable to use

- Shield (STP) cable
  - Length of 100 m or shorter
  - Make use of a Category 5 (or higher) cable .
- When connecting to a hub  
Make use of a straight cable.
  - When connecting to a computer  
Make use of a cross cable.

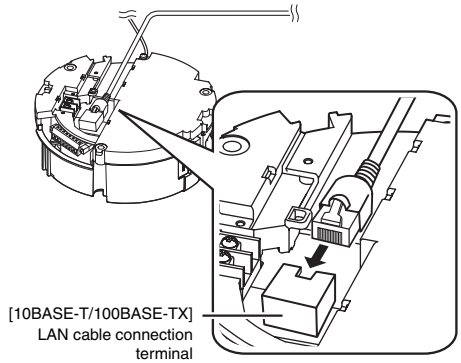

#### Note:

- However, cross cables cannot be used with some computer models. When connecting this unit directly to a computer, check the computer's LAN specifications in advance.

## Connecting the alarm signal terminal

Connect the alarm signal cable to external devices, such as a sensor or buzzer.

### Cable to use

- Length of 50 m or shorter
- UL1007, UL1015 or equivalent products
- AWG#22 to AWG#18 or equivalent products

- 1 Loosen screws on both sides of the terminal block with a flathead screwdriver and remove the terminal block as shown in the diagram below.

### Memo:

- Inserting the tip of the screwdriver into the slit of the terminal block will remove the terminal block easily.

- 2 Peel off about 4 mm of the alarm signal cable covering and insert into the terminal.
- 3 Turn the screws at the side and secure the alarm signal cable.
- 4 When the alarm signal cable is secured, return the terminal block that was removed in ① to its original position.

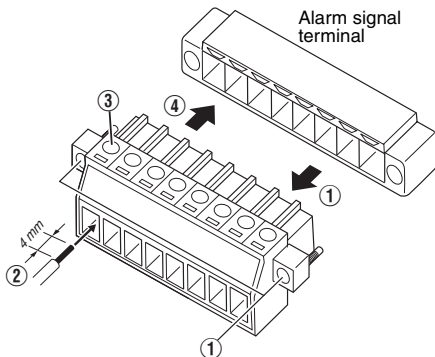

### Note:

- Noises from an external source may cause the camera to malfunction even when the cable used is within 50 m. In this case, move the cable away from the noise source.

## Alarm input signal

Connects to sensors such as infrared sensors, door sensors, metal sensors and manual switches.

- To prevent noise from entering the internal circuit, supply non-voltage contact signal to the alarm input signal.
- Do not supply voltage.
- When the contact is short (MAKE) or open (BREAK) on the menu, you can set it to Alarm.
- Supply such that the alarm signal continues for at least more than 500 ms. The alarm signal may not be recognized if it is less than 500 ms.

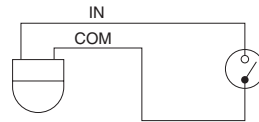

## Alarm output signal

Connect to alarm devices such as alarm, indicator, light or buzzer.

- Alarm output signal is an open collector output insulated with photo coupler.
- During an alarm, it is ON.
- As this terminal is polarized, be sure to connect it such that the voltage of the + output is higher than that of the - output.
- It will be damaged if reverse voltage is supplied.

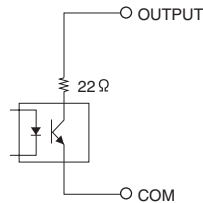

### Rating:

Max. applied voltage: DC 20 V  
Max. driving current: 25 mA

## Mounting the Camera

### Setting Up the Wall

Be sure to put on protective glasses to protect your eyes from falling objects when mounting the camera.

#### 1 Make holes in the wall

Make holes ( $\phi$  45 mm) for the connecting cables to pass through.

#### Note:

- Check the strength of the wall. A less firm wall may cause the unit to fall.

#### 2 Install the anchor bolts for mounting the camera

Install 4 anchor bolts (M8  $\times$  35 mm and above) to mount the camera.

#### 3 Install the anchor bolt for mounting the fall prevention wire

Install the anchor bolt (M8  $\times$  35 mm and above) to mount the fall prevention wire 30 mm below the center of the upper two anchor bolts that are used to mount the camera.

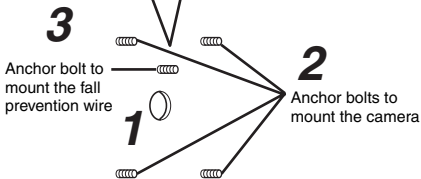
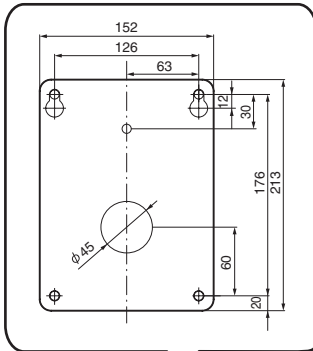

#### 4 Pull the cables from the hole in the wall

Pull the power cable, LAN cable and alarm signal cable from the wall.

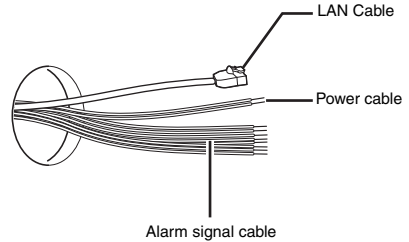

### Setting Up the Camera

#### 1 Remove the dome cover

Loosen the screws (x4) and remove the dome cover from the camera.

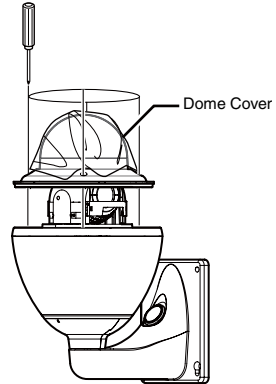

#### 2 Remove the cushioning material, lens cap and tape used during transporting

When installing the heater at an unrequired location, turn off the switch of the heater.

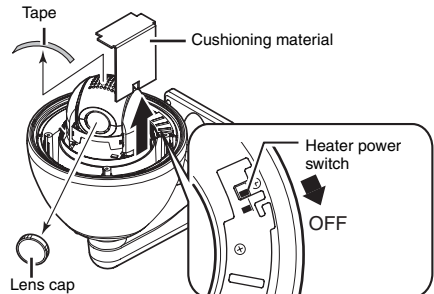

### 3 Insert silica gel (when using PoE power supply)

**Note:**

- Be sure to insert the provided silica gel in the position as shown in the diagram when using the PoE power supply. Otherwise, the camera lens may fog up or the image may become blur.

- ① Remove the screw and lift up the plate
- ② Take out 3 silica gels from the aluminum bag and insert them into the position as shown in the diagram.
- ③ Fasten the screw

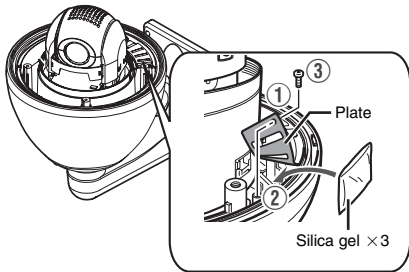

**Memo:**

- During reconnection or re-installation after repair or maintenance, make sure to replace the silica gel with a new one.
- Consult your nearby JVC's dealer on the replacement procedures. Serial number of part to be replaced: Use a LW40500-001A silica gel.

**Note:**

- When mounting is performed on a rainy day, make sure that rain water does not enter this unit.

### 4 Mount the dome cover to the camera

Use the screws (x4) to mount the dome cover to the camera. As a guide, install the three catches of the dome cover and the central mark. Install such that the central mark appears above the JVC mark of the camera.

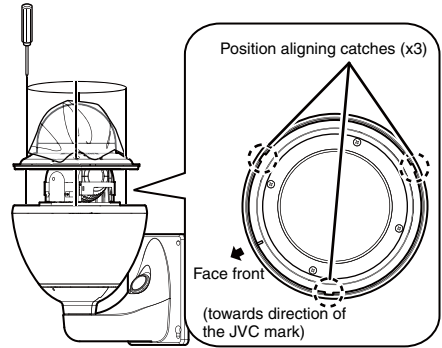

**Note:**

- Check that there is no dirt or dust inside the dome cover before mounting.
- When installing on a rainy day, ensure that raindrops do not enter the interior.
- When mounting the dome cover, temporarily secure the 4 screws and then tighten.
- As a guide, tighten the screws to 0.5 N•m to 1 N•m (5 kg•cm to 10 kg•cm). If the tightening is loose, the dome cover may fog due to water seepage.

### 5 Remove the cable connection cap

Remove the cap on the arm of the camera.

### 6 Pull out the cables from the cable connection hole

Pull out the cables (except the fall prevention wire) of the camera from the cable connection hole.

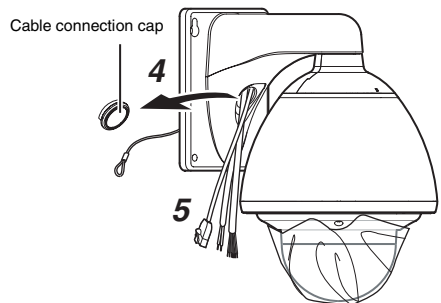

## Mounting the Camera (continued)

### Mounting the Camera

#### 1 Mount the fall prevention wire

- Mount the fall prevention wire of the camera to the fall prevention wire anchor bolt that was installed earlier.
- Secure the fall prevention wire tightly with a nut and washer.

#### 2 Pull out the cables (from the wall) from the cable connection hole.

#### 3 Mount the camera to the wall

- Mount the camera to the camera anchor bolts that were installed earlier.
- Secure the camera tightly with a nut and washer.

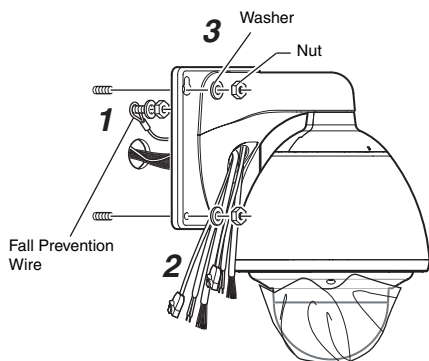

#### Note:

- This product weighs approximately 5.5kg. When installing, pay extra attention as it may fall.
- For your safety, hold the arm section during installation.
- After installing, paint the nuts and washers to prevent corrosion.

#### Memo:

- To remove the camera, follow the reverse procedures.

### Cable Connection

#### 1 Connecting the power cable

(☞ Page 30)

Connect the power cable and wind the waterproof tape (adhesive). After connecting, push the cable into the arm of the camera.

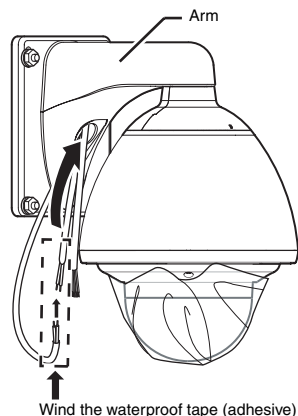

#### 2 LAN Cable Connection (☞ Page 31)

- ① Use the provided RJ-45 conversion connector and connect the LAN cable.
- ② Wind the connector section with waterproof tape (adhesive) and push the cable into the arm of the camera.

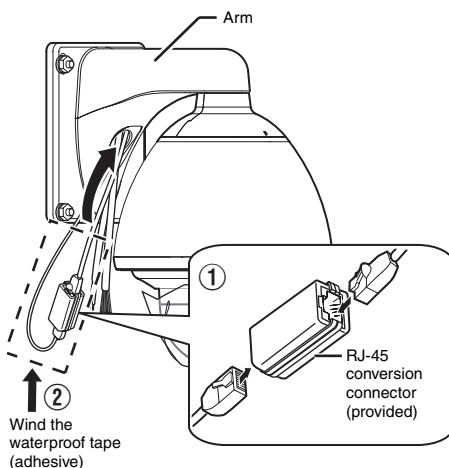



---

### 3 Connecting the alarm cable (see Page 25)

Connect the alarm cable and wind the waterproof tape (adhesive). After connecting, push the cable into the arm of the camera.

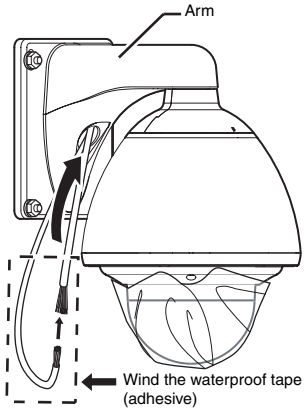

- Note:**
- For cables that are not used, be sure to wrap the ends individually with insulating tape.
  - For safety reasons, turn on the power only after all the connection is complete.
- 

### 4 Mount the cap

### 5 Seal the cable connection hole and around the mounting surface of the camera with waterproof seal (GE silicon).

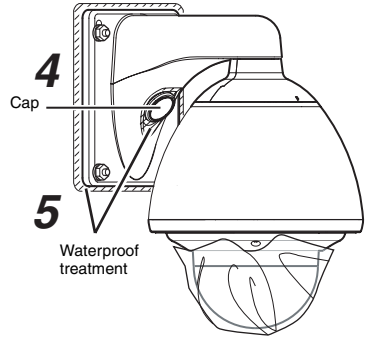

- Note:**
- Ensure that waterproof treatment is performed. Otherwise, the camera may malfunction due to rain water seepage.
  - Use GE silicon or other similar product for the sealing material.
- 

### 6 Remove the dome cover protective sheet

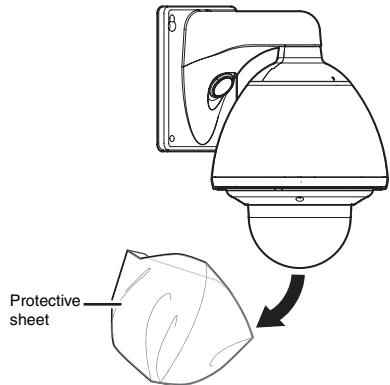

## Power Connection

Power can be supplied to this camera either by connecting to an AC 24 V power supply or using PoE (Page 31).

**Note:**

- If power is supplied from both power cable and LAN cable, priority will be given to the power supply from the power cable.
- Be sure to use an AC 24 V supply that is isolated from the primary power supply circuit. Using a variable voltage power supply will cause the camera and system to malfunction or breakdown.
- The unit is to be powered by an AC 24 V power supply. The AC 24 V power supply should conform to the following: Class 2 only (For USA), Isolated power supply only (For Europe and others).

### Connecting the power cable

This connects the camera to AC 24 V power.

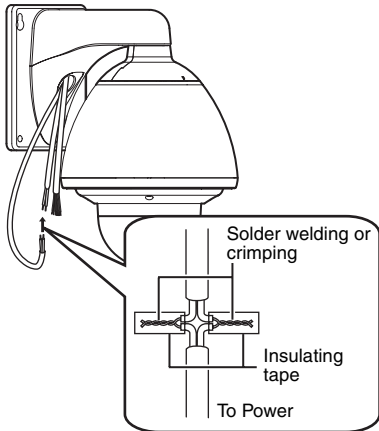

When using 2-core VVF (Vinyl-insulated vinyl-sheath cable), the connection distance is as follows: (Reference value)

Maximum connection distance	30 m	80 m	120 m	210 m
Conductor Diameter (mm)	ø1.0 and above	ø1.6 and above	ø2.0 and above	ø2.6 and above

### Warning

- The rated power of this product is AC 24 V, 50 Hz/60 Hz. Make sure to use it with the correct voltage.
- Supplying a power beyond the rated value may result in failures, smoke or fire. If the camera breaks down, turn off the power and contact our service center immediately.
- When a power beyond the rated value is supplied, the internal components may be damaged even if no abnormality is found on the appearance and operation of the camera. Please contact your nearest JVC dealer immediately for servicing (charged separately).

**Memo:**

- After DHCP timeout, all IP addresses of camera are set to 192.168.0.2 by default. If the power of multiple cameras within the same LAN environment are turned on at the same time, the IP addresses of the cameras overlap, thus preventing proper access. As such, make sure to turn on the power of the cameras one by one.
- In a system where multiple units of camera are used, turn on the power of only one unit to configure the IP address settings using the Internet Explorer. Upon doing so, turn on the power of the second unit and configure accordingly. Configure the subsequent camera settings using the same procedure.
- When overlapping of the IP address occurs, check to ensure that there is only one camera unit within the same LAN environment, and wait for a while (at least 10 minutes) or power off and on all network devices under the same LAN environment. Otherwise, access to the camera may fail.

**Note:**

- If thin cables are used, the resistance of the cables will be high and a significant voltage drop will occur when the camera is at its maximum power consumption (when pan, tilt and zoom operates at the same time). Either use a thick cable with low resistance or place the power supply near to the camera and shorten the length of the cable to restrict the voltage drop at the rated current of the camera to below 10 %. If voltage drops during operation, the camera may experience unstable performance and be unable to call up the preset position correctly.
- Do not connect an AC 24 V cable to AC 110 V/AC 230 V power supply. The camera internal circuit will be damaged.
- Should that happens, do not use the camera. Bring it to your nearest JVC dealer for repair.
- Turn on the power only after the connection for all the devices is complete.
- After the power is turned on and activation is completed, this product will move to the home position.

## Using PoE

Supply power to the camera by connecting it to a device that supports PoE via a LAN cable.

### What is PoE (Power over Ethernet)?

PoE is a feature that transfers data and supplies power simultaneously through a LAN cable. It enables you to operate a LAN-compatible equipment without having to connect it to a power supply using a power cord.

#### Cable to use

- Shield (STP) cable
- Length of 100 m or shorter
- Make use of a Category 5 (or higher) cable .

#### Note:

- When power is supplied to VN-V686WPBU using PoE, the heater will not work. Use an AC 24 V power supply when using the camera in an environment under -10°C.

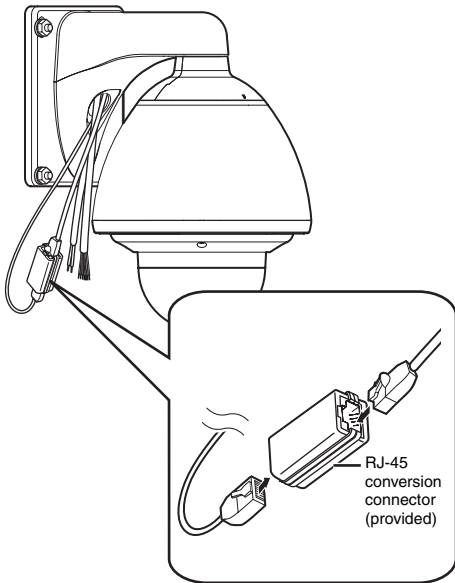

## LAN Cable Connection

Connect the camera to a hub or computer using a LAN cable.

### Cable to use

- Shield (STP) cable
  - Length of 100 m or shorter
  - Make use of a Category 5 (or higher) cable .
- When connecting to a hub  
Make use of a straight cable.
  - When connecting to a computer  
Make use of a cross cable.

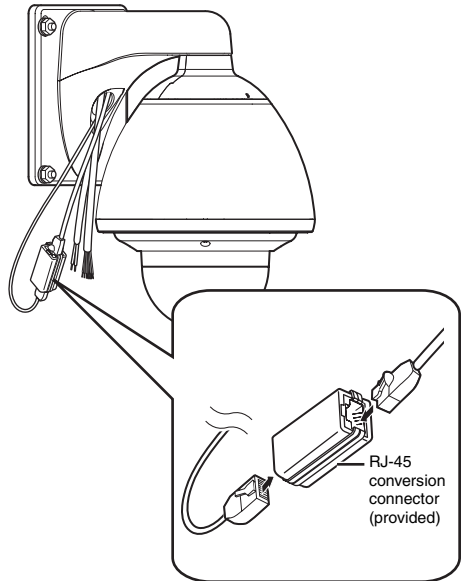

#### Note:

- However, cross cables cannot be used with some computer models. When connecting the camera directly to a computer, check the computer's LAN specifications in advance.

## Connecting the alarm signal cable

Connect the alarm signal cable to external devices, such as a sensor or buzzer.

### Cable to use

- Length of 50 m or shorter
- UL1007, UL1015 or equivalent products
- AWG#22 to AWG#18 or equivalent products

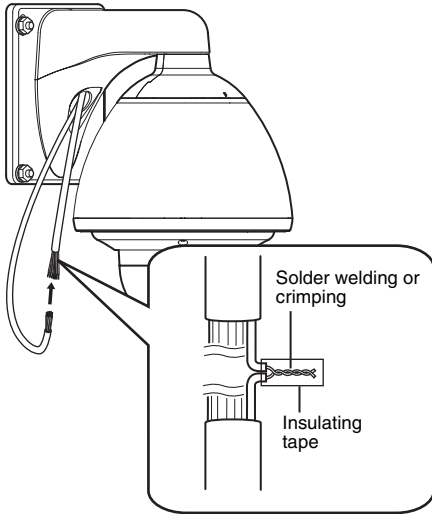

### Note:

- Noises from an external source may cause the camera to malfunction even when the cable used is within 50 m. In this case, move the cable away from the noise source.

## Alarm input signal

Connects to sensors such as infrared sensors, door sensors, metal sensors and manual switches.

- To prevent noise from entering the internal circuit, supply non-voltage contact signal to the alarm input signal.
- Do not supply voltage.
- When the contact is short (MAKE) or open (BREAK) on the menu, you can set it to Alarm.
- Supply such that the alarm signal continues for at least more than 500 ms. The alarm signal may not be recognized if it is less than 500 ms.

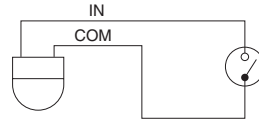

## Alarm output signal

Connect to alarm devices such as alarm, indicator, light or buzzer.

- Alarm output signal is an open collector output insulated with photo coupler.
- During an alarm, it is ON.
- As this terminal is polarized, be sure to connect it such that the voltage of the + output is higher than that of the - output.
- It will be damaged if reverse voltage is supplied.

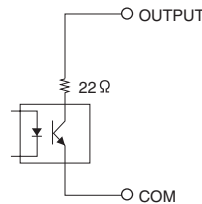

### Rating:

Max. applied voltage: DC 20 V  
Max. driving current: 25 mA

## Network Requirements

- Ensure that there is sufficient network bandwidth for the data volume to be sent out by the camera. Do not send multicast stream that exceeds the bandwidth. If the entire bandwidth is used by the multicast stream, control of this camera via the network may fail.
- Data volume to be sent by the camera varies with the settings and number of distributions.
- The maximum bit rate for transmission is about 20 Mbps.

## Estimation of Total Bit Rate

The total JPEG bit rate from the camera is determined by the camera settings, number of clients, and the client's requested number of frames. The total MPEG4 bit rate from the camera is determined by the number of distributions. Develop a design upon taking the above into consideration.

## Bit Rate of JPEG Stream

The JPEG file size per frame varies with the encoding settings as well as input video signals. The following table may be used as a reference.

### ■ AFS (Average File Size)

When AFS is selected, encoding will be performed such that the target file size is the average size of multiple JPEG images.

Selectable between 10 KB to 100 KB	Selectable between 3 KB to 33 KB
------------------------------------	----------------------------------

### ■ VFS(Variable File Size)

When VFS is selected, the quantization table during JPEG encoding will be maintained, and the file size will increase/decrease according to the input signals.

	VGA	QVGA
<b>1 (High)</b>	80 KB	27 KB
<b>2</b>	60 KB	20 KB
<b>3</b>	40 KB	13 KB
<b>4 (Medium)</b>	30 KB	10 KB
<b>5</b>	25 KB	8 KB
<b>6</b>	20 KB	7 KB
<b>7 (Low)</b>	15 KB	5 KB

The maximum number of distributions varies with the bit rate settings as well as the client's requested frame rate. Up to 20 streams can be distributed (including multicast). The total frame rate refers to the sum of these frame rates. For example, when 10 fps is requested by two clients, and in addition, multicast is transmitted at a rate of 10 fps, the total frame rate will be:

$$10 + 10 + 10 = 30 \text{ fps}$$

If the JPEG file size per frame is 30 KB, then the total bit rate will be:

$$30 \text{ KB} \times 30 \text{ fps} = 900 \text{ KB/s} = \text{Approx. } 7.2 \text{ Mbps}$$

## Network Requirements (continued)

### Bit Rate of MPEG4 Stream

You can select either the Variable Bit Rate (VBR) or Constant Bit Rate (CBR) system for MPEG4 stream. When the VBR system is selected, the bit rate varies according to the condition of the input video signals. The VBR system delivers a stable picture quality, but forecast of the bit rate is difficult.

When the CBR system is selected, encoding is performed at a fixed bit rate regardless of the condition of the input video signals. The picture quality varies under the CBR system, but the bit rate can be easily forecast.

You can specify an estimated bit rate for both VBR and CBR. (64 kbps to 8000 kbps)

### Restrictions on the Number of Distributions for Camera

The maximum number of distributions for this unit is determined by the settings as well as requirements from the client.

When only JPEG images are distributed, the maximum number of distributions is determined based on the highest bit rate within the stream. When a distribution request that exceeds the maximum number of distributions is received, this request is denied. For example, if Client A requests for and receives data at 1 Mbps, while Client B requests for and receives data at 5 Mbps, the maximum number of distributions is 4 streams according to the table below.

### Maximum number of distributions when only JPEG data is distributed

Distribution at maximum bit rate	Maximum number of distributions	Total maximum bit rate
1 Mbps and below	20	20 Mbps
5 Mbps and below	4	20 Mbps
10 Mbps and below	2	20 Mbps
Larger than 10 Mbps	1	Maximum configurable value (24 Mbps)

When only MPEG4 images are distributed, the maximum number of distributions is determined by the preset bit rate. When a distribution request that exceeds the maximum number of distributions is received, this request is denied.

### When distributing only MPEG4 data

Preset bit rate	Maximum number of distributions	Total maximum bit rate
0.6 Mbps and below	20	12 Mbps
3 Mbps and below	4	12 Mbps
6 Mbps and below	2	12 Mbps
Larger than 6 Mbps	1	Maximum configurable value (8 Mbps)

When both JPEG and MPEG4 images are distributed simultaneously, distribution up to two clients for JPEG and MPEG4 respectively is possible. However, distribution requests that exceed a total bit rate of 20 Mbps will be denied.

Total bit rate	Maximum number of distributions for JPEG	Maximum number of distributions for MPEG4
20 Mbps and below	2	2

### Insufficient network bandwidth

When there is insufficient bandwidth, the number of JPEG frames (frame rate) that the client can acquire will decrease. Delay will also occur in the distribution of images. In the case of MPEG4, noise interference may occur and playback may fail.

## Network Delay

When the client acquires JPEG via TCP, the camera will send out data while checking the ACK from the client at the same time. For networks with considerable delay, data cannot be sent out until ACK is received, and therefore the frame rate will drop. In the case of MPEG4, noise interference may occur and playback may fail.

Decrease in the frame rate due to network delays can be eliminated by receiving data via multicast.

## Network Jitter

When there is considerable network jitter, delay time may be prolonged and the image frame rate may drop. In the case of MPEG4, noise interference may occur and playback may fail.

## Packet Loss

When acquiring images from this unit via TCP, packet loss may be recovered by TCP retransmission. When there is considerable delay in the network, however, missing data may occur and the image frame rate may drop. In the case of MPEG4, noise interference may occur and playback may fail.

When packet loss occurs during multicast sending from this unit, the image frame rate may drop. In the case of MPEG4, noise interference may occur and playback may fail.

## List of Protocols and Port Numbers Used by this unit

This unit uses the protocols and port numbers listed below. Ensure that these ports are allowed through the firewall when a firewall is to be installed.

Protocol/Port No.	Purpose of Use
<b>Source</b>	
TCP/80	JPEG/MPEG4 server, Web Settings page, API
TCP/5510	VSIP
TCP/10020 TCP/10021 TCP/10023	(Reserved for adjustment)
TCP/32040	Alarm Server
<b>Destination</b>	
TCP/20, 21	FTP
TCP/25	Mail delivery
TCP/110	POP (Mail Delivery)
TCP/User Setting No.	Sending alarm
UDP/123	SNTP
UDP/5510	VSIP
UDP/9541	VSIP discovery protocol
UDP/User Setting No.	Sending alarm

## IP Address Settings

### IP address setting procedure

Follow the procedure below to configure the IP address of the camera.

#### Step1 IP address setting at the computer ( Pager37)

Set the IP address of the computer for configuring the camera settings.



#### Step2 Internet Explorer settings ( Pager38)

Configure the Internet Explorer settings in order to establish connection between the computer and the camera.



#### Step3 Connecting the camera to the computer ( Pager40)

Connect the computer to the camera.



#### Step4 IP address setting for the camera ( Pager42)

Set the [DHCP Disable] item on the [Basic Settings1] screen to "DHCP Enable" or "DHCP Enable".

#### ● System configuration required for setting IP address

Camera at factory default is set to "DHCP Enable" (DHCP client function is On). When it is connected to a LAN without DHCP servers, it will activate under the following IP address after timeout.

IP address : 192.168.0.2  
Subnet mask : 255.255.255.0  
Default gateway : None

#### Memo:

- To set a static IP address for the camera, connect the camera, the switching hub and the computer for setting using a straight LAN cable of Category 5 and above.

#### ● Set up the computer for setting the IP address.

##### ● Minimum computer specifications for setting

OS : Windows XP (Professional or Home Edition) (SP2)  
Web browser : Internet Explorer Version 6.0

#### Note:

- When setting the IP address of the camera, do so by using a network that is made up of only the camera, the computer for setting and the switching hub.
- Using a hub connected to other network devices or networks via a LAN cable for setting can cause problems.



## IP address setting at the computer

Set the computer to an IP address that enables communication with the camera.

### 1 Click [Start]

- Select in the sequence of [Control Panel]–[Network Connection]–[Local Area].

#### Windows Vista:

- Select in the sequence of [Settings]- [Control Panel]- [Network Center]- [Network Connection].

### 2 The computer on which Internet Explorer is launched automatically selects the connected network

- Right-click and select [Properties].
- Check to ensure that the [Client for Microsoft Networks] and [Internet Protocol(TCP/IP)] check boxes are selected.

#### Windows Vista:

- Check to ensure that the [Client for Microsoft Networks] and [Internet Protocol Version 4 (TCP/IPv4)] check boxes are selected.

### 3 Select [Internet Protocol(TCP/IP)] and click [Properties]

#### Windows Vista:

- Select [Internet Protocol Version 4 (TCP/IPv4)] and click [Properties].

### 4 Set the IP address

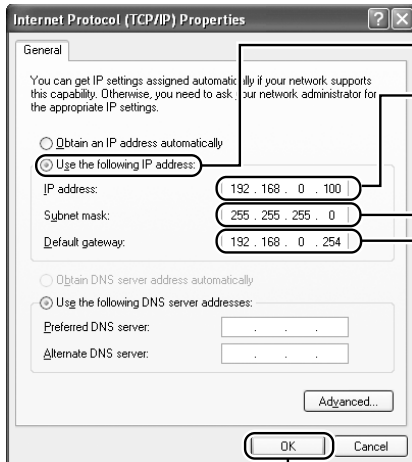

① Select [Use the following IP address].

② Specify the [IP address]. (For example, use 192.168.0.100 when the camera is in its default settings and there is no DHCP server.)

#### Memo:

Make sure that you take note of the original IP address before altering.

#### Note:

Ensure that a duplicate IP address is not specified within the same network environment.

③ Set [Subnet mask] to a value that is appropriate for the setting operation. Consult the network administrator if you have any queries.

(Use 255.255.255.0 the camera is in its default settings and there is no DHCP

④ When a [Default gateway] is present, make use of the corresponding IP address (e.g., 192.168.0.254).

⑤ Click [OK].

### 5 Click [OK] on the [Local Area Connection Properties] screen

## IP Address Settings (continued)

### Internet Explorer settings

#### 1 Launch the Internet Explorer on the computer

#### 2 When proxy settings are enabled in the Internet Explorer, follow the steps below to disable the proxy of the Internet Explorer

- Select in the order of [Tool]–[Internet Options]–[Connections]–[LAN Setting], followed by deselecting the check for [Use a proxy server for your LAN] under [Proxy Server] of the [Local Area Network (LAN) Settings] window.

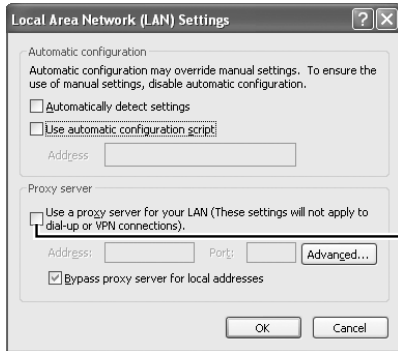

Deselect the check

#### 3 If the active script of the Internet Explorer is disabled, follow the steps below to enable it

- Select [Trusted sites] under [Tool]–[Internet Options]–[Security]. Upon doing so, the [Sites...] button directly below becomes active. Click this button and deselect the check [in the displayed window], and add the following web site to the zone.

**http://192.168.0.2**

- Next, select [Trusted sites] under [Tool]–[Internet Options]–[Security], and press the [Custom Level] button. Select [Enable] under [Scripting]–[Active script] of the [Security Settings] window that has been opened.

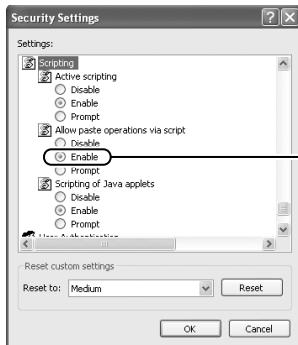

Select [Enable]

#### 4 If ActiveX controls and plug-ins of the Internet Explorer is disabled, follow the steps below to enable it

- Click [Trusted sites] under [Tool]–[Internet Options]–[Security]. Select the [Custom Level] button and open the [Security Settings] window. Set all items under [ActiveX controls and plug-ins] in the opened window to [Enable]. Enable also [Use the following IP address] under [Miscellaneous].

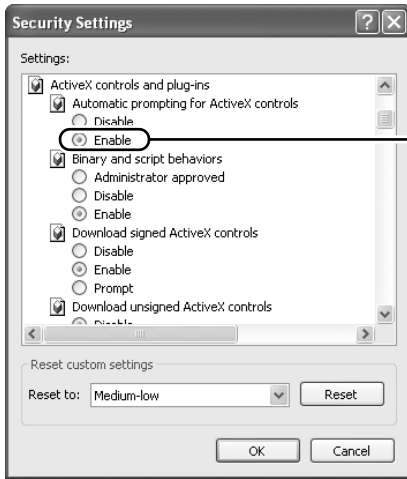

Select [Enable]

#### 5 Disable pop-up block

Connection of the camera cannot be established when pop-up block in the Internet Explorer is set to “Enable”.

Follow the steps below to set the pop-up block to “disable”.

- Selecting [Tool]–[Pop-up Blocker]–[Turn Off Pop-up Blocker] permits all sites.
- To allow only specific sites such as this unit, select [Tool]–[Pop-up Blocker]–[Turn On Pop-up Blocker], followed by selecting [Tool]–[Pop-up Blocker]–[Pop-up Blocker Settings] that becomes active to open the [Pop-up Blocker Settings] window.  
In the opened window, add the address of VN-V686BU as a permitted web site address.

#### 6 If plug-in tools are installed in the Internet Explorer, disable the pop-up block function of these plug-in tools as well.

## Connecting the camera to the computer

### IP Address Settings (continued)

#### 1 Launch the Internet Explorer

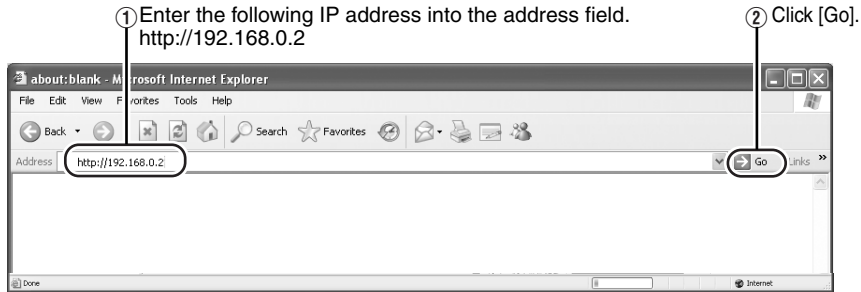

#### Memo:

- If the proxy server settings for access to the Internet via the Internet Explorer is enabled, you may not be able to specify the IP address directly. In this case, change the proxy settings of the Internet Explorer.
- After the [Security Settings] screen appears, press the [OK] button to proceed.

#### ■ When the IP address of the camera is unknown

IP address settings cannot be changed by accessing via a computer when the IP address of the camera is unknown. You can use the following method to identify the IP address.

- Search for the camera in the LAN using [Search tool] inside [Tool\_E] folder of the supplied CD-ROM.
- ※ For details on [Search tool], please refer to the “Readme” file in the CD-ROM supplied with this product.

#### 2 Enter the user name and password (login as administrator) (Page 44)

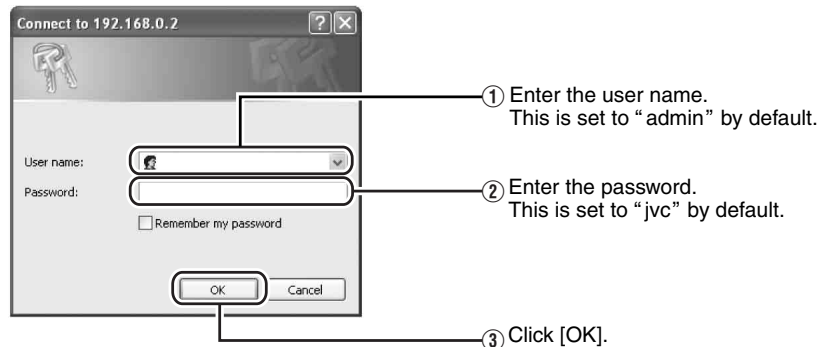

#### Memo:

- After the [Security Settings] screen appears, press the [Yes] button to proceed.

### 3 Built-in Viewer appears

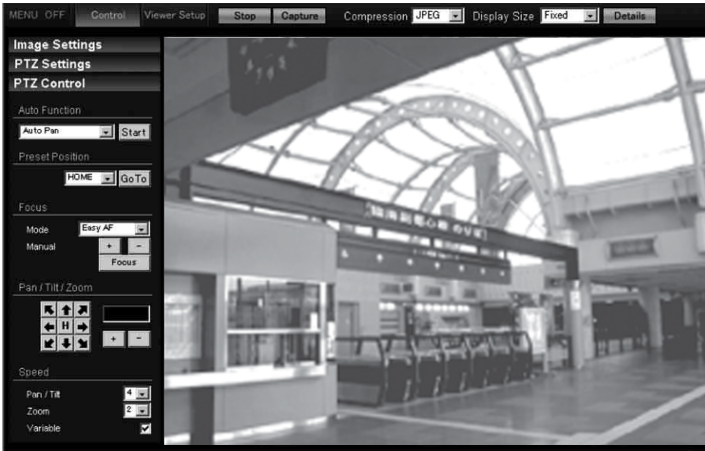

### 4 The Operator Password entry screen appears



- ① Operator Password (default password is "jvc")
- ② Click [OK].

**Memo:**

- The operator password entry screen does not appear if the password is stored on the computer. Proceed to configure the IP address. (Page 42)

## IP Address Settings (continued)

### IP address setting for the camera

#### 1 Click [Advanced Settings] of the Built-in Viewer

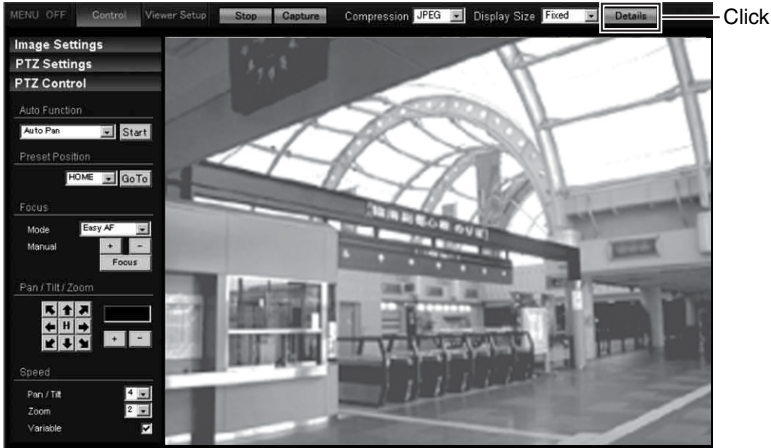

#### 2 The [Basic Settings1] screen appears

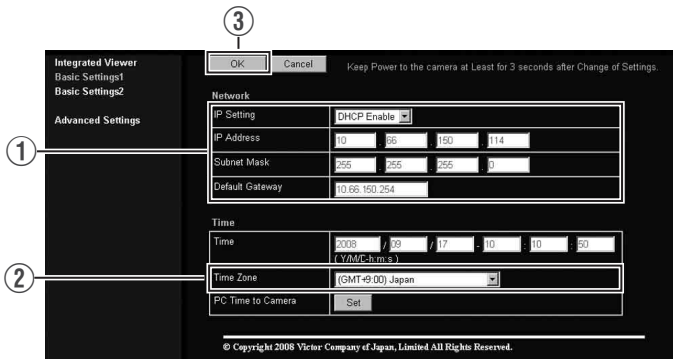

#### ① Specify the [DHCP Disable].

- When selecting “DHCP Enable”:  
The default setting is “DHCP Enable” (DHCP client function is Enabled). To assign an IP address from the DHCP server, connect the DHCP server to the LAN, set the [DHCP Disable] of the camera to “DHCP Enable”, and click the [OK] button. For details on IP addresses assigned to the camera, consult your network administrator.
- When selecting “DHCP Disable”:  
Select “DHCP Disable”, and specify a value in the [IP address], [Subnet Mask] and [Default Gateway] fields.

#### Note:

- Set the DHCP server such that the same IP address is always assigned to the MAC address of the camera by the DHCP server. Connection may fail if the above setting is not performed.

---

② Specify the [Time Zone].

③ Click [OK].

### 3 A confirmation screen appears

Click [OK].

Camera restarts using the new IP address. It takes about one minute for the camera to reboot.

**Memo:** \_\_\_\_\_

- Access from this computer may fail when the IP address of the camera is changed. To enable access to this unit from the same computer, alter the IP address at the computer accordingly.

**When the display or configuration of the opened screen appears strange, check the computer settings using the following procedures.**

① Click [Start]–[Control Panel]–[Display] and open the [Display Properties] window

② Click the [Settings] tab in the [Display Properties] window and click the [Advanced] button

③ Check that [DPI setting] in the [General] tab has become [Normal size(96DPI)]

④ Otherwise, change the setting to [Normal size(96DPI)] and reboot Windows

## IP Address Settings (continued)

### Enter user name and password

User name and password entry will be required at the beginning. (☞ Page 40)

There are three access authorization levels to the camera. The factory settings are as follows.

User Name	Default Password	Description
admin	jvc	All operations and setting changes are allowed
operator	jvc	Change of settings other than those related to network and maintenance are allowed
user	jvc	Viewing of images is allowed

### ● Pages that users have access to

Restrictions are placed on the pages that users have access to. In addition, links on the web pages are also displayed according to the access rights of the user.

### ● admin

Basic Settings1	[Network] [Time]
Basic Settings2	[Camera] [Encoding] [JPEG] [MPEG4]
Detailis	[Camera] [Encoding] [Alarm] [Alarm Environment] [PTZ] [Auto Patrol0] [Auto Patrol1] [Auto Patrol2] [Privacy Mask] [Motion detection] [Network Basic] [Network Details] [Protocol] [Streaming] [Access Restrictions] [Time] [Password] [Maintenance] [Miscellaneous] [Operation] [Settings] [Position List] [Patrol Information 0] [Patrol Information 1] [Patrol Information 2]

### ● operator

Basic Settings2	[Camera] [Encoding] [JPEG] [MPEG4]
Detailis	[Camera] [Encoding] [Alarm] [Alarm Environment] [PTZ] [Auto Patrol0] [Auto Patrol1] [Auto Patrol2] [Privacy Mask] [Motion detection] [Streaming] [Miscellaneous] [Operation] [Settings] [Position List] [Patrol Information 0] [Patrol Information 1] [Patrol Information 2]



- 
- user

Detailis	[Miscellaneous]
----------	-----------------

**Memo:** \_\_\_\_\_

- Security Information window may appear before the top page is displayed. Press the [OK] button to proceed.

If you do not want this warning screen to be displayed, change the Internet Explorer settings as follows.

- Open [Tool]–[Internet Options]–[Security] and select the [Trusted sites] icon.
- Next, press the [Custom Level] button, followed by selecting “Enable” for [Miscellaneous]–[Display mixed content].

**Note:** \_\_\_\_\_

- Do not reset or turn off the power of camera immediately after the settings are changed. Otherwise, changes may not be saved or may be saved incorrectly.
  - If settings are changed when sending JPEG or MPEG4, the transmission may be temporarily cancelled.
-

## Setting

### How to open the setting page

#### 1 Enter the IP address of the camera in the address bar of Internet Explorer (☞ Page 40)

- A Built-in Viewer is opened.

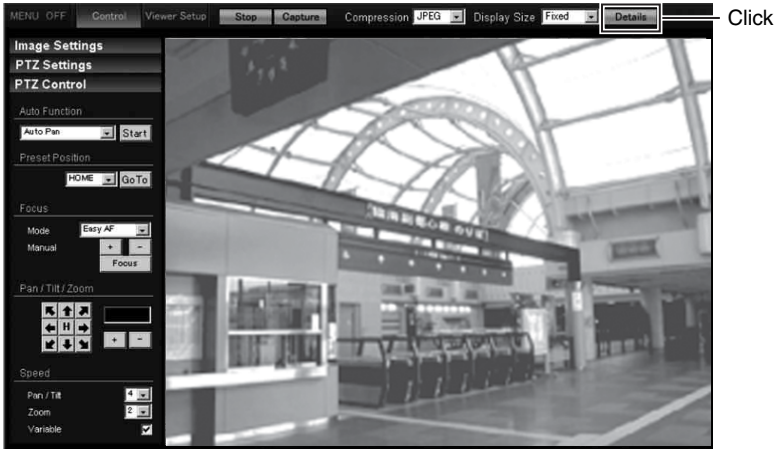

#### 2 Click [Details]

- [Basic Settings1] page will be opened if accessed by user name "admin". (☞ Page 47)
- [Basic Settings2] page will be opened if accessed by user name "operator". (☞ Page 48)
- [Miscellaneous] page will be opened if accessed by user name "user". (☞ Page 94)

## Basic Settings1

This page is for performing basic setting related to the network.

- This page can be used during access using “admin”.
- Click [Basic Settings1].
- Press the [OK] button to enable the new settings.
- If the [OK] button is pressed upon entering an invalid value, a warning message will appear and the entry will be denied. Press the [Cancel] button to restore the invalid entry to the current value.

Click

### Memo:

- You can open the [Basic Settings1] screen without going through Built-in Viewer by entering direct URL address in the address field of Internet Explorer.

When the IP address of the camera is 192.168.0.2 for example, enter the URL below.

VN-V685U : <http://192.168.0.2/cgi-bin/v685display.cgi?v685basicmenu1.html>

VN-V686BU/VN-V686WPBU : <http://192.168.0.2/cgi-bin/v686display.cgi?v686basicmenu1.html>

Network	
① IP Setting	For setting the DHCP client function. Connect the camera to a network environment with a DHCP server when DHCP is to be enabled. If the DHCP server does not exist when [IP Setting] is set to “DHCP Enable”, the camera will start running with IP address 192.168.0.2 and subnet mask 255.255.255.0 in about 2 minutes after startup. (☞ Page 42)
② IP Address	For setting the IP address of the camera.
③ Subnet Mask	For setting the Subnet Mask of the camera.
④ Default Gateway	For setting the Default Gateway of the camera. Set as 0.0.0.0 when the Default Gateway is not set.
Time	
⑤ Time	Displays the clock time of the camera. The time transmitted by the camera is recorded in the JPEG header. Discontinuity may occur in the JPEG header's time immediately before and after changing the time.
⑥ Time Zone	For setting the time zone.
⑦ Pc time to Camera	Click the [Set] button to set the time of the computer on the camera.

# Setting Using Internet Explorer

## Basic Settings2

Page for setting fundamental parameters of Camera, JPEG and MPEG4.

- This page can be used during access using “admin” or “operator”.
- Click [Basic Settings2].
- Press the [OK] button to enable the new settings.
- If the [OK] button is pressed upon entering an invalid value, a warning message will appear and the entry will be denied. Press the [Cancel] button to restore the invalid entry to the current value.

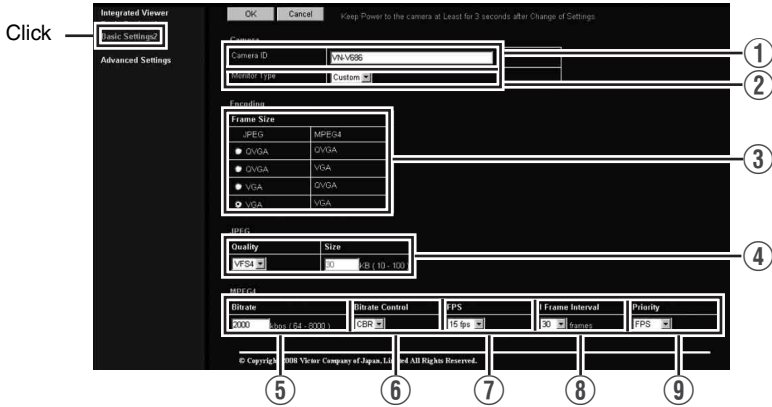

### Memo:

- You can open the [Basic Settings2] screen without going through Built-in Viewer by entering direct URL address in the address field of Internet Explorer.

When the IP address of the camera is 192.168.0.2 for example, enter the URL below.

VN-V685U : <http://192.168.0.2/cgi-bin/v685display.cgi?v685basicmenu2.html>

VN-V686BU/VN-V686WPBU : <http://192.168.0.2/cgi-bin/v686display.cgi?v686basicmenu2.html>

Camera	
① <b>Camera ID</b>	Character strings entered here will be written to the JPEG comment segment (item name: Camera). Refer to the [API Guide] (provided CD-ROM) on the file formats of JPEG.
② <b>Monitor Type</b>	<p>For selecting the monitor type according to the monitor used to display the video images. The picture quality varies according to the type of monitor selected.</p> <p>Custom :Enables setting of picture quality according to the user's preference. You can configure the detailed settings on the [Camera] page. (☞ Page 51)</p> <p>LCD1, LCD2 :Picture quality setting for LCD monitors. Two types are available for selection according to the user's preference.</p> <p>CRT :Picture quality setting for CRT (cathode-ray tube) monitors.</p> <p><b>[Setting value:Custom, LCD1, LCD2, CRT]</b></p>
Encoding	
③ <b>Frame Size</b>	<p>For setting the frame size of each JPEG or MPEG4 screen to VGA (640 x 480) or QVGA (320 x 240). Select one of the four different patterns.</p> <p><b>Memo:</b> _____</p> <ul style="list-style-type: none"> <li>● Refer to the API Guide on the file formats of JPEG.</li> </ul>
JPEG	
④ <b>Quality/ Size</b>	<p>For specifying the JPEG picture quality (rate control mode) and size (target file size). When "VFS1" to "VFS7" is selected, the quantization table during JPEG encoding will be maintained and the file size will increase/decrease according to the input signals. Typical sizes will be displayed in the Size field. When recording JPEG data to a recorder with a limited storage capacity, the maximum recording time may vary as the file size fluctuates under this setting.</p> <p>When "AFS" is selected, encoding is performed such that the target file size is the average size of multiple JPEG images. You can enter the target size in the Size field.</p> <p>[Picture quality values:VFS1 to VFS7, AFS]</p> <p><b>Memo:</b> _____</p> <p>The picture size can be specified only when the picture quality value is set to AFS.</p> <p>[Size field setting range for VGA:10 KB to 100 KB ] [Size field setting range for QVGA:3 KB to 33 KB ]</p>

### Setting (continued)

#### Basic Settings2 (continued)

MPEG4	
⑤ <b>Bitrate</b>	For setting the MPEG4 encoding bit rate. <b>[Setting range: 64 kbps to 8000 kbps]</b>
⑥ <b>Bitrate Control</b>	For selecting whether to set the MPEG4 rate control mode to CBR (Constant Bit Rate) or VBR (Variable Bit Rate).  CBR : Encoding is performed at a fixed bit rate regardless of the condition of the input video signals. Enables easy forecast of the bit rate.  VBR : Changes the bit rate according to the condition of the input video signals. Picture quality is stable, but forecast of the bit rate is difficult.
⑦ <b>FPS</b>	For setting the MPEG4 frame rate. <b>[Setting range: 1 fps, 7.5 fps, 10 fps, 15 fps, 25 fps, 30 fps]</b>
⑧ <b>I Frame Interval</b>	For setting the I-frame interval. MPEG4 starts encoding from the I-frame. Shortening the interval stabilizes the picture quality even when there are rapid changes in the video image. However, the picture quality for images with little change will deteriorate. In addition, when multicast packet loss occurs, the time interval required to restore the image is shorter. <b>[Setting value:30, 60, 90, 120, 150]</b>
⑨ <b>Priority</b>	For selecting whether to assign priority to the frame rate or picture quality during MPEG4 encoding.  FPS : Assigns priority to frame rate. Select this setting to enable smooth monitoring of motion images.  Quality : Prioritizes image quality.

## Camera Page

This page is for setting the camera's parameters.

This page can be used during access using "admin" or "operator".

- Click [Advanced Settings] to display setting menu.
- Click [Camera]. Press the [OK] button to enable the new settings.
- If the [OK] button is pressed upon entering an invalid value, a warning message will appear and the entry will be denied. Press the [Cancel] button to restore the invalid entry to the current value.
- To restore the settings of this page to the factory settings, press [Initialize] button.

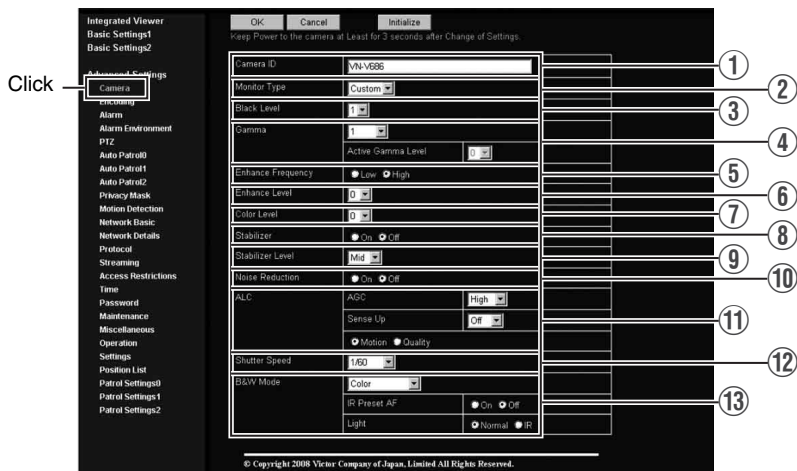

<p>① <b>Camera ID</b></p>	<p>Character strings entered here will be written to the JPEG comment segment (item name: "Camera"). Refer to the [API Guide] (provided CD-ROM) on the file formats of JPEG.</p>
<p>② <b>Monitor Type</b></p>	<p>For selecting the monitor type according to the monitor used to display the video images. The picture quality varies according to the type of monitor selected.</p> <p>Custom : Enables setting of picture quality according to the user's preference.</p> <p>LCD1, LCD2 : Picture quality setting for LCD monitors. Two types are available for selection according to the user's preference.</p> <p>CRT : Picture quality setting for CRT (cathode-ray tube) monitors.</p> <p><b>[Setting value:Custom, LCD1, LCD2, CRT]</b></p>
<p>③ <b>Black Level</b></p>	<p>For adjusting the black level. Lowering the value darkens the video image. Increasing the value brightens the image.</p> <p><b>[Setting range:0 to 2]</b></p> <p><b>Memo:</b> _____</p> <ul style="list-style-type: none"> <li>• If the black level is set to "0", this may be too low depending on the connected device, or dark area will become complete black.</li> <li>• When using MPEG4 images, set to either "1" or "2".</li> </ul>

### Setting (continued)

#### Camera Page (continued)

<p>④ <b>Gamma</b></p>	<p>To alter the appearance of dark areas in a video image, adjust the gamma curve.</p> <p>0 : Gamma correction suitable for CRT is performed.</p> <p>1 : Gamma correction suitable for some LCDs is performed.</p> <p>2 : Do not perform gamma correction. This setting is suitable for some LCDs.</p> <p>Active : The most appropriate gamma correction is applied according to the darkness of the screen. Select the level under [Active Gamma Level].</p> <p><b>[Setting value:0, 1, 2, Active]</b></p> <p><b>Memo:</b></p> <ul style="list-style-type: none"> <li>• The set value is fixed when the [Monitor Type] ② is set to “LCD1”, “LCD2”, or “CRT”.</li> </ul>
<p><b>Active Gamma Level</b></p>	<p>This adjusts the effect when [Gamma] ④ is set to “Active”. Objects with little luminance difference→Decrease the number Objects with large luminance difference→Increase the number</p> <p><b>[Setting range:-5 to 0 to 5]</b></p> <p><b>Memo:</b></p> <ul style="list-style-type: none"> <li>• The color may appear different from the actual one depending on the object.</li> <li>• Noise interference and hue changes may appear prominent depending on the brightness of the object but this is not a malfunction.</li> <li>• This feature can only be configured when [Gamma] ④ is set to “Active”.</li> </ul>
<p>⑤ <b>Enhance Frequency</b></p>	<p>For setting the type of edge enhancement.</p> <p>Low : Enhanced edges become thicker.</p> <p>High : Enhanced edges become thinner.</p> <p><b>[Setting value:Low, High]</b></p> <p><b>Memo:</b></p> <ul style="list-style-type: none"> <li>• The set value is fixed when the [Monitor Type] ② is set to “LCD1”, “LCD2”, or “CRT”.</li> </ul>
<p>⑥ <b>Enhance Level</b></p>	<p>For setting the intensity of edge enhancement.</p> <p>Larger value : Increases the intensity of edge enhancement.</p> <p>Smaller value : Decreases the intensity of edge enhancement.</p> <p><b>[Setting range:-5 to 0 to 5]</b></p>
<p>⑦ <b>Color Level</b></p>	<p>For adjusting the color level.</p> <p>Larger value : Increases the color level.</p> <p>Smaller value : Decreases the color level.</p> <p><b>[Setting range:-5 to 0 to 5]</b></p>



<p><b>⑧ Stabilizer</b></p>	<p>This function prevents image shaking caused by vibration. Set this function to “On” to control image shaking.</p> <p>Off : Disabled. On : Enabled.</p> <p><b>Memo:</b> _____</p> <ul style="list-style-type: none"> <li>• When the function is set to “On”, the screen is digitally zoomed to approximately 1.3 times.</li> <li>• Adjustment is disabled in the electronic zoom area.</li> <li>• Adjustment is disabled for about 1 minute after power ON and during Pan/Tilt/Zoom operation.</li> <li>• Adjustment may not work when the vibration is fast. The effect can be small when vibration direction does not match with Pan/Tilt position. Depending on the installation environment, the stabilizer may malfunction and increase image shaking due to the vibration transmitting to the camera. In this case, set the stabilizer to “Off”.</li> </ul>
<p><b>⑨ Stabilizer Level</b></p>	<p>This item allows you to set the adjustment level of the [Stabilizer] item ⑧ in 3 steps. The adjustment volume is larger if the value is set to “High” rather than “Mid”. When it is set to “Low”, the adjustment volume is lesser than compared to when it is set to “Mid”.</p> <p><b>[Setting value:Low,Mid,High]</b></p>
<p><b>⑩ Noise Reduction</b></p>	<p>When “On” is set, image noise on the screen will be reduced.</p> <p><b>Memo:</b> _____</p> <ul style="list-style-type: none"> <li>• This item is only enabled when [AGC] item ⑪ is set to a value other than “Off”.</li> <li>• Image noise in dark images will be reduced but the resolution will deteriorate.</li> <li>• The edges between high and low illumination area may appear rough.</li> </ul>
<p><b>⑪ ALC</b></p>	<p>For setting the priority of ALC (feature for maintaining the video level according to the brightness of the object). You can select whether to assign priority to the motion or picture quality when the object becomes dark.</p> <p>Motion : Prioritizes movement. When the object becomes dark, priority is given to AGC (automatic gain control), and therefore this is suitable for shooting fast-moving objects.</p> <p>Quality : Prioritizes image quality. When the object becomes dark, priority is given to the Sense Up feature, and therefore this is suitable for shooting objects requiring a high picture quality.</p> <p><b>[Setting value:Motion,Quality]</b></p>

## Setting (continued)

### Camera Page (continued)

<b>⑪ ALC (continued)</b>	
<b>AGC</b>	<p>For setting the AGC (automatic gain control) level.</p> <p>Off : Disables the AGC feature</p> <p>Mid : When the amount of light is insufficient</p> <p>High : When the amount of light is particularly insufficient</p> <p>Super : When the brightness level is insufficient even upon setting to “High”.</p> <p><b>[Setting value: Off, Mid, High, Super]</b></p> <p><b>Memo:</b> _____</p> <ul style="list-style-type: none"> <li>• The screen appears grainy at dark locations when the AGC feature is in use.</li> </ul>
<b>Sense Up</b>	<p>This feature is used to raise the sensitivity level by lengthening the exposure time.</p> <p>You can specify the number of times by which the sensitivity level is to be increased automatically when the object becomes dark. When “x32” is selected, the sensitivity is changed dynamically up to 32 times (as compared to the “Off” mode) to fit to current darkness. When sensitivity increases, the shutter speed becomes slower and hence, movement becomes unnatural. When set to “Off”, Sense Up is disabled.</p> <p><b>[Setting value: Off, x2, x4, x8, x16, x32, x64, x128]</b></p> <p><b>Memo:</b> _____</p> <ul style="list-style-type: none"> <li>• Upon raising the sensitivity level, the screen may appear grainy or white, or white defects may occur. However, this is not a malfunction.</li> <li>• When [Sense Up] is set to a value other than “Off”, flickers occur under the light of fluorescent or mercury lamps. This is not a malfunction of the camera, but is due to principles related to Sense Up.</li> <li>• When the [Shutter Speed] item ⑫ is set to “1/100” to “1/10000”, set [Sense Up] to “Off”.</li> </ul>
<b>⑫ Shutter Speed</b>	<p>This item sets the speed of the electronic shutter.</p> <p>When [Sense Up] item ⑪ is set to “x2” or above, available setting value is “1/60” or “1/100” only.</p> <p><b>[Setting value: 1/60, 1/100, 1/250, 1/500, 1/1000, 1/2000, 1/4000, 1/10000]</b></p> <p><b>Memo:</b> _____</p> <ul style="list-style-type: none"> <li>• Flickering of fluorescent lightings can be reduced when the shutter speed is set to “1/100” or “1/60” respectively in regions of commercial power frequency 50 Hz and 60 Hz.</li> <li>• The faster the shutter speed is, a smear phenomenon specific to CCD, where white bands appear vertically along bright light source, is more emphasized.</li> <li>• The edges between high and low illumination area may appear rough.</li> </ul>

<p>⑬ <b>B/W Mode</b></p>	<p>This sets the function to switch from Color to B&amp;W mode.</p> <p>Color : Always be in Color mode.</p> <p>Black &amp; White : Always be in B&amp;W mode.</p> <p>Auto Low,Auto Mid,Auto High</p> <p>: This item automatically switches between Color Mode and B&amp;W Mode when the luminance meets defined conditions for over 30 seconds. Select the sensitivity from three options.</p> <p><b>Memo:</b> _____</p> <p><b>To ensure a successful B&amp;W/Color switching</b></p> <ul style="list-style-type: none"> <li>● If the [B/W Mode] item is set to “Auto Low, Auto Mid, Auto High”, the B&amp;W/Color setting can be switched according to the brightness of the object, but the condition of illumination and field angle may make this impossible. To be absolutely certain of B&amp;W/Color switching, connecting external sensor to alarm input cable of this camera and setting alarm action of B&amp;W mode is recommended.</li> </ul>
<p><b>IR Preset AF</b></p>	<p>When switching the Color mode to B&amp;W mode, the type of light source may cause the focus to be dislocated. This is because the B&amp;W mode is sensitive to both visible light and near-infrared light. When this happens, set this item to “On” to focus automatically.</p> <p>On : Enabled.</p> <p>Off : Disabled.</p>
<p><b>Light</b></p>	<p>This item sets the illumination of the object during B&amp;W mode.</p> <p>Normal : Select this for normal illumination.</p> <p>IR : Select this when using infrared illumination.</p> <p><b>Memo:</b> _____</p> <ul style="list-style-type: none"> <li>● If “IR” is set under normal sunlight or fluorescent lighting, the camera will not switch normally from Color to B&amp;W mode.</li> </ul>

## Setting (continued)

### Encoding Page

This page is for setting JPEG and MPEG4 encoding parameters.

This page can be used during access using “admin” or “operator”.

- Click [Advanced Settings] to display setting menu.
- Click [Encoding]. Press the [OK] button to enable the new settings. Press the [OK] button to enable the new settings.
- If the [OK] button is pressed upon entering an invalid value, a warning message will appear and the entry will be denied. Press the [Cancel] button to restore the invalid entry to the current value.
- When settings on this page are altered during playback using Built-in Viewer, reboot the Built-in Viewer.
- There is a maximum limit to the bit rate for transmission by the camera. If a bit rate that exceeds the maximum limit is specified, this new setting will not be applied. For details on the maximum transmission limit, refer to [Network Requirements] (Page 33).

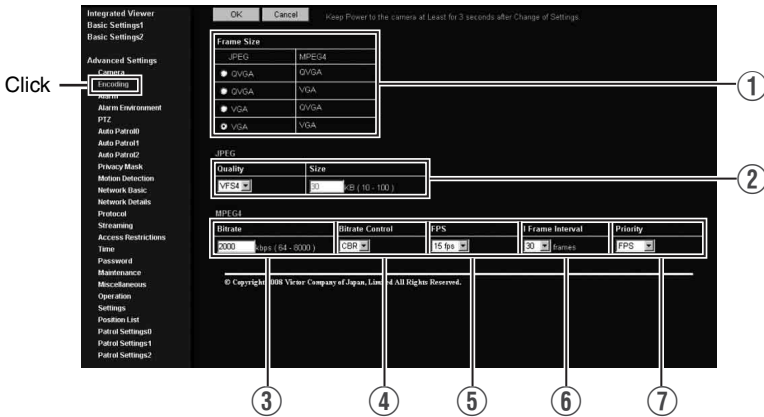

#### ① Frame Size

For setting the frame size of each JPEG or MPEG4 screen to “VGA” (640 x 480) or “QVGA” (320 x 240).  
Select one of the four different patterns.

<b>JPEG</b>	
<b>② Quality/Size</b>	<p>For specifying the rate control mode and target file size for JPEG. When “VFS1” to “VFS7” is selected, the quantization table during JPEG encoding will be maintained and the file size will increase/decrease according to the input signals. Stipulated values will be displayed in the Size field. When recording JPEG data to a recorder with a limited storage capacity, note that the maximum recording time may vary as the file size fluctuates under this setting.</p> <p>When “AFS” is selected, encoding is performed such that the target file size is the average size of multiple JPEG images. You can enter the target size in the [Size] field.</p> <p><b>[Size field setting range for VGA: 10KB to 100KB (Only when setting “AFS”)]</b>  <b>[Size field setting range for QVGA: 3KB to 33KB (Only when setting “AFS”)]</b></p>
<b>MPEG4</b>	
<b>③ Bitrate</b>	<p>For setting the MPEG4 encoding bit rate.</p> <p><b>[Setting range:64kbps to 8000kbps]</b></p>
<b>④ Bitrate Control</b>	<p>For selecting whether to set the MPEG4 rate control mode to CBR (Constant Bit Rate) or VBR (Variable Bit Rate).</p> <p>CBR : Encoding is performed at a fixed bit rate regardless of the condition of the input video signals. Enables easy forecast of the bit rate.</p> <p>VBR : Changes the bit rate according to the condition of the input video signals. Picture quality is stable, but forecast of the bit rate is difficult.</p>
<b>⑤ FPS</b>	<p>For setting the MPEG4 frame rate.</p> <p><b>[Setting range:1 fps, 7.5 fps, 10 fps, 15 fps, 25 fps, 30 fps]</b></p>
<b>⑥ I Frame Interval</b>	<p>For setting the I-frame interval. MPEG4 starts encoding from the I-frame. Shortening the interval stabilizes the picture quality even when there are rapid changes in the video image. However, the picture quality for images with little change will deteriorate. In addition, when multicast packet loss occurs, the time interval required to restore the image is shorter.</p> <p><b>[Setting value:30, 60, 90, 120, 150]</b></p>
<b>⑦ Priority</b>	<p>For selecting whether to assign priority to the frame rate or picture quality during MPEG4 encoding.</p> <p>FPS : Assigns priority to frame rate. Select this setting to enable smooth monitoring of motion images.</p> <p>Quality : Prioritizes image quality.</p> <p><b>Memo:</b> _____</p> <ul style="list-style-type: none"> <li>● Valid when [Bitrate Control] ④ is “CBR”. When a very small bit rate is set for the frame rate or frame size, “CBR” or “VBR” will become the lowest images and a difference will appear in the frame rate. “Quality” which skips frames will be able to realize small bit rates better than “FPS”.</li> </ul>

## Setting (continued)

### Alarm Page

This page is for setting actions when there is an alarm.  
Up to 5 actions (No. 01 to No. 05) may be set.

This page can be used during access using “admin” or “operator”.

- Click [Advanced Settings] to display setting menu.
- Click [Alarm]. Press the [OK] button to enable the new settings.
- Press the [OK] button to enable the new settings. Only items that are valid under the selected action will be saved. When Disable is selected for the action, all settings will be restored to their default values.
- If the [OK] button is pressed upon entering an invalid value, a warning message will appear and the entry will be denied. Press the [Cancel] button to restore the invalid entry to the current value.

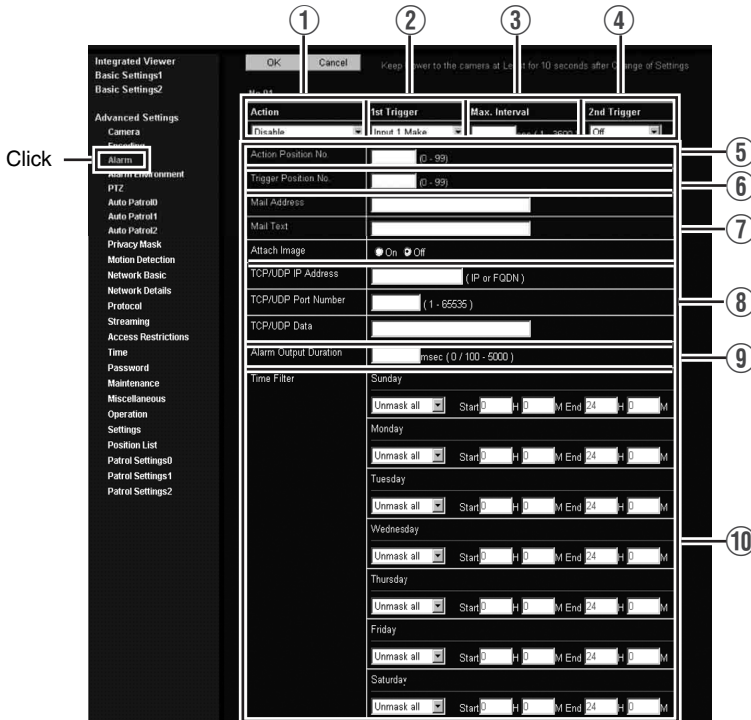

① Action

For specifying the type of action.

Disable : Does not trigger any action.

Mail : Sends out e-mail. Specify the recipient's mail address. The title of the mail will appear as [Alarm from VN-V685(VN-V685U)][Alarm from VN-V686(VN-V686BU/VN-V686WPBU)] and the sender as [Camera ID]. Enter the message to send in [Mail Text]. Input up to 127 alphanumeric characters. To attach the latest image to the mail, set [Attach Image] to "On".

PrePostRecording + FTP

: Sends out pre-/post-recorded JPEG files via FTP. See the page on Alarm Environment for details on pre-/post-recording and FTP server settings. (☞ Page 62)

The maximum transmission rate of FTP is 1 Mbps. If a new FTP trigger occurs during post-recording, the recorded portion is treated as pre-recording and a new post-recording starts. During FTP transmission after completing the post-recording, a new post-recording starts if a new FTP trigger occurs.

TCP : Sends out the character string entered in the [TCP/UDP Data] field to the destinations specified in [TCP/UDP IP Address] and [TCP/UDP Port Number] via TCP.

UDP : Sends out the character string entered in the [TCP/UDP Data] field to the destinations specified in [TCP/UDP IP Address] and [TCP/UDP Port Number] via UDP.

TCP/UDP Data

:Input up to 127 alphanumeric characters.

PinOutput 1 Make :Changes Alarm Output 1 to Make.

PinOutput 1 Breake :Changes Alarm Output 1 to Break.

PinOutput 2 Make :Changes Alarm Output 2 to Make.

PinOutput 2 Breake :Changes Alarm Output 2 to Break. Set the alarm output time in the [Alarm Output Duration] field.

Position : This item moves the camera to the position set in [Action Position No.] ⑤.

BlackWhite → Color

: Changes the [B/W Mode] setting from "Black & White" to "Color".

Color → BlackWhite

: Changes the [B/W Mode] setting from "Color" to "Black & White".

DayNight:Auto Low

: Changes the [B/W Mode] setting to "Auto Low".

DayNight:Auto Mid

: Changes the [B/W Mode] setting to "Auto Mid".

DayNight:Auto High

: Changes the [B/W Mode] setting to "Auto High".

**Memo:** \_\_\_\_\_

- For details on [B/W Mode], see [B/W Mode] (☞ Page 55).

## Setting (continued)

### Alarm Page (continued)

<p>② <b>1st Trigger</b></p>	<p>This item specifies the first trigger to the operation set in [Action] ①.  <b>[Setting value:Input 1 Make, Input 2 Make, Input 1 Break, Input 2 Break, Motion Detection, Fan Stop, Position, BlackWhite → Color, Color → BlackWhite]</b></p> <p><b>Memo:</b> _____</p> <ul style="list-style-type: none"> <li>• When the second trigger is turned off, the action will be invoked only by the first trigger.</li> <li>• When “Motion Detection”, “Fan Stop”, “Position”, “BlackWhite→Color”, “Color → BlackWhite” is selected as the first trigger, selection of “Max. Interval” and “2nd Trigger” will be disabled.</li> </ul>
<p>③ <b>Max. Interval</b></p>	<p>Enabled when both the first and second triggers are specified. Specify the maximum interval between the first and second triggers. An action will be invoked only if the interval between the first and second triggers is within the maximum interval.  <b>[Setting range:1sec to 3600sec]</b></p>
<p>④ <b>2nd Trigger</b></p>	<p>This item specifies the second trigger to the operation set in [Action] ①.  <b>[Setting value:Off, Input 1 Make, Input 2 Make, Input 1 Break, Input 2 Break]</b></p>
<p>⑤ <b>Action Position No.</b></p>	<p>This item sets the position number for trigger when “Position” is selected in [Action] ①.  <b>[Setting range:0 to 99]</b></p>
<p>⑥ <b>Trigger Position No.</b></p>	<p>This item sets the position number for trigger when “Position” is selected in [1st Trigger] ②.  <b>[Setting range:0 to 99]</b></p>
<p>⑦ <b>Mail</b></p>	<p>Mail Address : For entering the recipient's mail address.          Mail Text : For entering the mail transmission data. Input up to 127 alphanumeric characters.          Attach Image : For specifying whether to attach images to the mail.</p>



<p>⑧ <b>TCP/UDP</b></p>	<p>TCP/UDP IP Address  : For entering the address when alarm action notification is to be sent via TCP or UDP. (IP or FQDN)</p> <p>TCP/UDP Port Number  : For entering the port number when alarm action notification is to be sent via TCP or UDP. (1-65535)</p> <p>TCP/UDP Data  : For entering the data to send during TCP or UDP notification. Input up to 127 alphanumeric characters.</p>
<p>⑨ <b>Alarm Output Duration</b></p>	<p>For setting the alarm output time from the alarm output terminal. When this is set to “0”, it is not possible to revert back to break (or make) after changing to make (or break).  <b>[Setting range:0/100msec to 5000msec]</b></p>
<p>⑩ <b>Time Filter</b></p>	<p>For specifying the alarm action with respect to each day of the week and setting the corresponding time of the day.</p> <p>Applicable day of week  : Sunday, Monday, Tuesday, Wednesday, Thursday, Friday, Saturday</p> <p>Alarm action : Mask span  Unmask span  Mask All  Unmask All</p> <p>Applicable time period  : For specifying the Start and End time in hours and minutes.</p>

## Setting (continued)

### Alarm Environment Page

This page is for setting alarm-related environments.

This page can be used during access using “admin” or “operator”.

- Click [Advanced Settings] to display setting menu.
- Click [Alarm Environment]. Press the [OK] button to enable the new settings. Press the [OK] button to enable the new settings.
- If the [OK] button is pressed upon entering an invalid value, a warning message will appear and the entry will be denied. Press the [Cancel] button to restore the invalid entry to the current value.



<p>① Mail</p>	<p>For setting the mail environment when “Mail” is specified as an [Action]① on the Alarm page.  [SMTP] and [POP] can be used. Configure only the [SMTP] settings under usual circumstances.  Enter the camera’s mail address as the [Send Mail Address].  Configure the [POP] settings as well if [POP before SMTP] is set to “Off”. In addition, if “FQDN” is set for [SMTP Server], configure also the [DNS Server] settings on the Basic page. (☞ Page 79)</p> <p><b>Memo:</b> _____</p> <p><b>What is FQDN (Fully Qualified Domain Name)?</b>  This is a fully qualified domain name that indicates a notation method of describing the entire host or domain name on the TCP/IP network without abbreviating.  For example, if the host name is “www” and the domain name is “jvc.co.jp”, this will be denoted as “www.jvc.co.jp” in FQDN. Japanese cannot be used in FQDN.</p>
<p>② FTP</p>	<p>For setting the FTP environment when “FTP” is specified as an [Action]① on the Alarm page. This is common with the FTP environment when using the periodic FTP on this page.  When [Directory] is left blank, FTP transfer will be performed to the home directory of the FTP server. To enable FTP transfer to a directory below the home directory, set the corresponding directory name in [Directory].  Delimit the directory using “/”.  Example: subdir1/subdir2  Destination directory of FTP transfer will be dependent on the FTP server if “/” is added at the beginning.  Setting [Periodic FTP] to “On” enables transfer of the latest JPEG images to the FTP server at regular intervals. Specify the interval in seconds for [Periodic FTP Interval].  File name: Select a type from the two types of periodic FTP file names.  When “Auto” is selected, file names are generated from the year, month, day, hour, minute, second, and number.  Example: 20071114161032-001-2.jpg  When “Manual” is selected, you can select a file name generation method from the following.</p> <ul style="list-style-type: none"> <li>● File name containing only the character string entered in [User-defined-name]  Example: Camera1.jpg</li> <li>● File name with the year, month, day, hour, minute, and second added to [User-defined-name]  Example: Camera1_20071114161032001.jpg</li> </ul> <p>The name of the file to be transmitted via FTP is made up of the action number, year, month, day, hour, minute, second, number and trigger flag.  Example: 01-20070711152904-001-0.jpg  The first two digits are the action number, and the following 14 digits denote the year, month, day, hour, minute and second.  The three digits after the first hyphen is the number of the series of JPEG files to be sent via the FTP. The number starts from “000”. The last digit denotes the trigger flag. This is displayed as “1” only for the JPEG file during a trigger input, and as “0” if otherwise.</p>

## Setting (continued)

### Alarm Environment Page (continued)

Periodic FTP Naming	<input checked="" type="radio"/> Auto (YYYYMMDDHHMMSS-NNN2.jpg) <input type="radio"/> Manual <input checked="" type="radio"/> With timestamp (User-defined name/YYYYMMDDHHMMSSNNN.jpg) <input type="radio"/> Fixed (User-defined-name.jpg) User-defined-name: <input type="text"/>
Periodic FTP Time Filter	Sunday Unmask all <input type="checkbox"/> Start <input type="text"/> : <input type="text"/> : <input type="text"/> M End <input type="text"/> : <input type="text"/> : <input type="text"/> M Monday Unmask all <input type="checkbox"/> Start <input type="text"/> : <input type="text"/> : <input type="text"/> M End <input type="text"/> : <input type="text"/> : <input type="text"/> M Tuesday Unmask all <input type="checkbox"/> Start <input type="text"/> : <input type="text"/> : <input type="text"/> M End <input type="text"/> : <input type="text"/> : <input type="text"/> M Wednesday Unmask all <input type="checkbox"/> Start <input type="text"/> : <input type="text"/> : <input type="text"/> M End <input type="text"/> : <input type="text"/> : <input type="text"/> M Thursday Unmask all <input type="checkbox"/> Start <input type="text"/> : <input type="text"/> : <input type="text"/> M End <input type="text"/> : <input type="text"/> : <input type="text"/> M Friday Unmask all <input type="checkbox"/> Start <input type="text"/> : <input type="text"/> : <input type="text"/> M End <input type="text"/> : <input type="text"/> : <input type="text"/> M Saturday Unmask all <input type="checkbox"/> Start <input type="text"/> : <input type="text"/> : <input type="text"/> M End <input type="text"/> : <input type="text"/> : <input type="text"/> M
PrePostRecording Frame Rate	15 fps
PrePostRecording Before Trigger	5 msec (0 - 60)
PrePostRecording After Trigger	5 msec (0 - 60)
Alarm Output	Duration Output1: 000 msec (0 / 100 - 5000) Output2: 000 msec (0 / 100 - 5000) Manual Output Output1: <input type="checkbox"/> Make <input type="checkbox"/> Break <input type="checkbox"/> CurrentOutput: <input type="checkbox"/> Break Output2: <input type="checkbox"/> Make <input type="checkbox"/> Break <input type="checkbox"/> CurrentOutput: <input type="checkbox"/> Break
OK Cancel Keep Power to the camera at Least for 10 seconds after Change of Settings.	

© Copyright 2008 Victor Company of Japan, Limited All Rights Reserved.

<p>② <b>FTP (continued)</b></p>	<p>Setting the Periodic FTP Time Filter:</p> <p>For specifying the periodic FTP transfer action with respect to each day of the week and setting the corresponding time of the day.</p> <p>Applicable day of week  : Sunday, Monday, Tuesday, Wednesday, Thursday, Friday, Saturday</p> <p>Alarm action : Mask span  Unmask span  Mask All  Unmask All</p> <p>Applicable time period: For specifying the Start and End time in hours and minutes.</p> <p>Pre-/Post-recording parameter:  [PrePostRecording Frame Rate]  : For specifying the JPEG frame rate for FTP pre-/post-recording.  <b>[Setting value:1 fps, 2 fps, 3 fps, 5 fps, 6 fps, 7.5 fps, 10 fps, 15 fps, 30 fps]</b></p> <p>[PrePostRecording Before Trigger]  : For setting the FTP pre-recording trigger time (recording time before alarm input) in seconds.  <b>[Setting value:0sec to 60sec]</b></p> <p>[PrePostRecording After Trigger]  : For setting the FTP post-recording trigger time (recording time after alarm input) in seconds.  <b>[Setting value:0sec to 60sec]</b></p> <p>The maximum time intervals for [PrePostRecording Before Trigger] and [PrePostRecording After Trigger] are determined by the JPEG size on the Encoding page as well as [PrePostRecording Frame Rate]. A message appears if the combination of the entered values are not feasible.</p>				
<p>③ <b>Alarm Output</b></p>	<p>For setting the alarm output.</p> <table border="1" data-bbox="112 1029 1036 1327"> <tr> <td data-bbox="112 1029 300 1098"> <p><b>Duration</b></p> </td> <td data-bbox="311 1029 1036 1098"> <p>For setting the output time of [Manual Output].  <b>[Setting range:0 / 100 msec to 5000 msec]</b></p> </td> </tr> <tr> <td data-bbox="112 1098 300 1327"> <p><b>Manual Output</b></p> </td> <td data-bbox="311 1098 1036 1327"> <p>For operating alarm output manually.  The current output status appears on the right. When [Duration] is set to "0", pressing the [Make] button switches the alarm to Make output, while pressing the [Break] button switches the alarm to Break output.  When [Duration] is set to a value other than "0", pressing the [Make] button switches the alarm to Make output only during the duration of the output, upon which it switches to Break output.  When the output duration is set to a value other than "0", pressing the [Break] button switches the alarm to Break output only during the duration of the output, upon which it switches to Make output.</p> </td> </tr> </table>	<p><b>Duration</b></p>	<p>For setting the output time of [Manual Output].  <b>[Setting range:0 / 100 msec to 5000 msec]</b></p>	<p><b>Manual Output</b></p>	<p>For operating alarm output manually.  The current output status appears on the right. When [Duration] is set to "0", pressing the [Make] button switches the alarm to Make output, while pressing the [Break] button switches the alarm to Break output.  When [Duration] is set to a value other than "0", pressing the [Make] button switches the alarm to Make output only during the duration of the output, upon which it switches to Break output.  When the output duration is set to a value other than "0", pressing the [Break] button switches the alarm to Break output only during the duration of the output, upon which it switches to Make output.</p>
<p><b>Duration</b></p>	<p>For setting the output time of [Manual Output].  <b>[Setting range:0 / 100 msec to 5000 msec]</b></p>				
<p><b>Manual Output</b></p>	<p>For operating alarm output manually.  The current output status appears on the right. When [Duration] is set to "0", pressing the [Make] button switches the alarm to Make output, while pressing the [Break] button switches the alarm to Break output.  When [Duration] is set to a value other than "0", pressing the [Make] button switches the alarm to Make output only during the duration of the output, upon which it switches to Break output.  When the output duration is set to a value other than "0", pressing the [Break] button switches the alarm to Break output only during the duration of the output, upon which it switches to Make output.</p>				

## Setting (continued)

### PTZ Page

This page is used for specifying Auto Return, Auto Tracking, Intelligent Tracking, Move Preset Position, and Auto Flip.

This page can be used during access using “admin” or “operator”.

- Click [Advanced Settings] to display setting menu.
- Click [PTZ]. Press the [OK] button to enable the new settings. Press the [OK] button to enable the new settings.
- If the [OK] button is pressed upon entering an invalid value, a warning message will appear and the entry will be denied. Press the [Cancel] button to restore the invalid entry to the current value.

<p>① <b>Auto Return</b></p>	<p>If the camera is not operated over the duration that was set in “Return Time”, it will automatically return to the state that was set in “Mode”.</p>
<p><b>Mode</b></p>	<p>This item sets the operation after Auto Return.</p> <p>none : Auto Return is disabled.</p> <p>Home : Returns to the home position.</p> <p>Auto Pan : Returns to the Auto Pan operation.</p> <p>Auto Patrol : Returns to the Auto Patrol operation.</p> <p>Auto Trace : Returns to the Auto Trace operation.</p> <p>Auto Tracking : Returns to the automatic tracking operation.</p> <p>Intelligent Tracking : Returns to the Intelligent Tracking operation.</p>

## ① Auto Return (continued)

### Return Time

This item sets the time to return the operation with Auto Return. This feature cannot be configured when the [Mode] is set to “none”.

**[Setting value: 1 minute, 2minutes, 3minutes, 5minutes, 10minutes, 20minutes, 30minutes, 60minutes]**

#### Memo:

- When the [Mode] item is set to “Intelligent Tracking”, the camera returns to the home position after the specified Return Time has elapsed, and action restarts from the detection of tracked objects. When the Intelligent Tracking operation is in progress, PTZ may not function even when an object is being captured. If PTZ operations do not function for a time interval specified in “Return Time”, Auto Return starts automatically.

### Test

Click [Execute] to test run the configured Auto Return operation.

## ② Auto Tracking/ Intelligent Tracking

For configuring settings related to Auto Tracking and Intelligent Tracking.

**Auto Tracking** : Moves to the home position when Auto Return starts. Shoots the object by tracking it automatically when motion is detected at the home position. Zoom ratio is fixed at x1.

**Intelligent Tracking**

: Intelligent Tracking is available in two modes, namely the Auto mode which starts automatically from Auto Return, and the Manual mode for specifying a target on the viewer. You can change the object to track freely by clicking the viewer's display area when the camera is in the “Locked” or “Losing” mode. To exit, press the [Stop] button on the PTZ Controller screen.

- Auto mode
  - Detects the color information of the object for which motion is detected at the home position, and shoots the object by tracking it with automatic pan/tilt/zoom operations. You can switch to the Manual mode by clicking on the viewer screen before any motion is detected.
- Manual mode (☞ Page 113)
  - Select “Intelligent Tracking” under the [Function] item on the PTZ Control screen, and press the [Start] button to switch to the “Standby” mode. Once you click on the viewer screen to specify a target, the camera automatically tracks and shoots the target object while performing automatic pan/tilt/zoom operations.

#### Memo:

- Auto tracking may be difficult under the following conditions.
  - When multiple moving objects are in the same screen
  - When there is a flickering light source in the screen
  - When the speed of the moving object is too fast or slow
  - When the moving object is too big or small
  - When the object and background have same brightness
- Intelligent tracking may be difficult under the following conditions.
  - Strong backlight
  - Colors that are similar to the tracking target are present in the same screen
  - No colors on the tracking target (such as white, gray, black)
  - When the tracking target moves into the privacy mask area

## Setting (continued)

### PTZ Page (continued)

<p>② <b>Auto Tracking/ Intelligent Tracking (continued)</b></p>	<p><b>Memo:</b> _____</p> <ul style="list-style-type: none"> <li>Intelligent tracking cannot begin under the following conditions. <ul style="list-style-type: none"> <li>[B/W Mode] is set to “Black &amp; White” (☞ Page 55)</li> <li>[B/W Mode] is set to “Auto” and black and white is selected (☞ Page 55)</li> <li>[Auto Flip] is set to “Digital Flip” (☞ Page 71)</li> <li>All areas of detected motion are masked (☞ Page 76)</li> <li>The zoom ratio exceeds 20x. (The zoom ratio of the home position exceeds 20x if Intelligent Tracking is started by Auto Return.)</li> </ul> </li> <li>Dark images can be improved with the [Sense Up] (☞ Page 54) function but the tracking may be slow.</li> </ul> <p><b>Note:</b> _____</p> <ul style="list-style-type: none"> <li>The Auto Tracking function of this camera detects changes in brightness. As such, depending on changes in the illumination, it may or may not detect movement of objects having the same color as the background color. It may be difficult to detect objects with very slow movement. Check the operating conditions thoroughly beforehand and configure the settings such that there will not be any misoperation or omission of detection.</li> <li>When [Stabilizer] (☞ Page 53) is set to “OFF”, this function starts from home position and initial detect area is the screen of the home position without enlargement. When [Stabilizer] is set to “ON”, as the screen is enlarged, it will also respond to motion of image which is not shown on the screen. This is the specification of this unit, not a malfunction.</li> </ul>
<p><b>Restart Time</b></p>	<p><b>Auto Tracking</b> : This item sets the duration to return to the home position when there is no movement in the images after auto tracking starts.</p> <p><b>Intelligent Tracking</b> : When Intelligent Tracking loses the object, you can return to the home position after the preset [Restart Time] has elapsed. For Intelligent Tracking, the camera does not return to home position while the object is locked even if the object does not move.</p> <p><b>[Setting value:Off, 10seconds, 20seconds, 30seconds, 40seconds, 50seconds, 60seconds, 120seconds]</b></p> <p><b>Note:</b> _____</p> <ul style="list-style-type: none"> <li>When the [Mode] item of [Auto Return]① is set to “Auto Tracking” and the [Return Time] is set shorter than the [Restart Time] for [Auto Tracking]②, the camera will operate according to the [Return Time].</li> </ul>
<p><b>Auto Tracking Level</b></p>	<p>This item sets the detection sensitivity of Auto Tracking/Intelligent Tracking. To lower the sensitivity → Decrease the number To increase the sensitivity → Increase the number <b>[Setting range:0 to 10]</b></p>



③ <b>Intelligent Tracking</b>	This item sets the zoom for [Intelligent Tracking].
<b>Tracking Zoom</b>	When this item is set to “On”, the zoom ratio changes according to the movement of the object.
<b>Tracking Zoom Limit</b>	<p>When [Tracking Zoom] is set to “On”, this item sets the threshold limit of the zoom ratio.</p> <p>When Intelligent Tracking is started, tracking is possible if the zoom ratio is within 20x, even if the current zoom ratio has exceeded the [Tracking Zoom Limit]. In that case, behaviour of automatic zoom changes according to the [Tracking Zoom] setting as follows.</p> <ul style="list-style-type: none"> <li>● [Tracking Zoom] is “On”: Tracking starts at the current zoom ratio. If the [Tracking Zoom Limit] is exceeded, the camera moves in the WIDE direction but not in the TELE direction. Once the zoom ratio enters the [Tracking Zoom Limit], the camera will zoom within the configured tracking zoom limit.</li> <li>● [Tracking Zoom] is “Off”: The camera tracks objects at the current zoom ratio. The zoom ratio will not change.</li> </ul>
④ <b>Limit</b>	
<b>Zoom Limit</b>	<p>When the zoom lens is operated to TELE side, optical zoom works and electronic zoom works after optical zoom becomes full. This item sets the maximum value of the electronic zoom function.</p> <p><b>[Setting range: Off, 1, 2, 4, 8, 16, 32]</b></p> <p><b>Memo:</b> _____</p> <ul style="list-style-type: none"> <li>● As electronic zoom processes the images digitally, image quality will deteriorate somewhat.</li> <li>● Increasing the electronic zoom ratio will shift the center of the screen toward the top left. This is a characteristic of this camera and is not a malfunction.</li> <li>● The camera will not operate continuously from optical zoom to electronic zoom. When the optical zoom is full, release and press again the [+] button of [Zoom] in [PTZ Controller]. [PTZ Control] (☞ Page 113)</li> </ul>
<b>Pan Limit</b>	<p>This item sets the movable range of the pan (horizontal) operation during manual operation when “On” is selected. It is invalid when “Off” is selected.</p> <p>[Set Left], [Set Right] button : Click these buttons to set the current position to the left or right edge.</p> <p>[Go to Left], [Go to Right] button : Click these buttons to move the camera to the preset left or right edge.</p> <p><b>Memo:</b> _____</p> <ul style="list-style-type: none"> <li>● It does not affect the Preset Position, Auto Pan and Auto Trace operations.</li> </ul>

## Setting (continued)

### PTZ Page (continued)

<b>④Limit (continued)</b>	<p><b>■ Basic operation of Pan Limit</b></p> <p>When [Pan Limit] is set to “On”, panning is only available in the effective area. When the camera is moved to prohibited area by some operation that has priority over [Pan Limit] and manual panning is performed, it operates in the following manner.</p> <ul style="list-style-type: none"><li>● Panning can be operated freely even in the prohibited area before the camera enters the effective area.</li><li>● Once the camera enters the effective area, the [Pan Limit] settings take over and pan operation can only be performed in the effective area.</li></ul> <p><b>● Operations that have priority over Pan Limit</b></p> <p>The following operations are available regardless of the prohibited areas set in [Pan Limit].</p> <ul style="list-style-type: none"><li>● Auto Pan</li><li>● Auto Trace</li><li>● Move Preset Position</li><li>● Auto Flip</li><li>● Auto Tracking</li></ul> <p><b>● Settings that have priority over Pan Limit</b></p> <p>The following settings come together with pan operation but they can be set regardless of the prohibited areas even when [Pan Limit] is set to “On”.</p> <ul style="list-style-type: none"><li>● Privacy Mask Setting</li><li>● Auto Pan setting</li></ul> <p><b>Memo:</b></p> <ul style="list-style-type: none"><li>● When setting Auto Trace and Preset Position and the [Pan Limit] setting is “On”, panning is unavailable in the prohibited area.</li><li>● As Auto Trace and Move Preset Position have priority over manual pan limit, setting pan limit after setting Auto Trace or Preset Position does not prevent Auto Trace or Preset Position operation.</li></ul>
<b>Tilt Limit</b>	<p>This item sets the movable range of the tilt (vertical) operation during manual operation.</p> <p>When this item is set to 10, the movable range of the tilt operation is from 10 to 90 degrees. It cannot operate between -5 and 9 degrees.</p> <p><b>[Setting range:-5 Degrees to 0 Degrees to 10 Degrees]</b></p> <p><b>Memo:</b></p> <ul style="list-style-type: none"><li>● When the camera is moved to prohibited area by some operation that has priority over tilt limit and tilt operation is performed manually, it operates in the following manner.</li><li>● Tilt operation is disabled in the prohibited area. Tilt will be forcibly moved to the effective area.</li><li>● Once the camera enters the effective area, the tilt limit settings take over and tilt operation can only be performed in the effective area.</li><li>● It does not affect the Preset Position, Auto Pan and Auto Trace operations.</li></ul>

⑤ <b>Preset Position Speed</b>	This item sets the speed of moving to the preset position. It is also applicable when moving to the preset position in Auto Patrol.
<b>Speed</b>	<b>[Setting value:1 to 4]</b>
⑥ <b>Auto Flip</b>	<p>Set this item when shooting objects that pass right under the camera. Otherwise, following operations are necessary to shoot objects that pass right under the camera.</p> <ol style="list-style-type: none"> <li>① Turn the camera to face down</li> <li>② Rotate the camera 180 ° horizontally</li> <li>③ Turn the camera to face up</li> </ol> <p>You can use the [Auto Flip] function to perform the above operations automatically.</p> <p>Off : Auto Flip function does not activate.</p> <p>Digital Flip : The top/bottom and left/right of the image flips when tilt position passed the angle of 135 degrees.</p> <p>Mode1 : When the camera faces bottom, it rotates 180 ° horizontally and stops. In this case, the operating direction of the camera is the same as that of the Pan/Tilt operation.</p> <p>Mode2 : When the camera faces bottom, it rotates 180 ° horizontally and the operating direction of the camera is opposite that of the Tilt operation. Select this mode if you wish to operate continuously. Once operation stops, the direction will return to normal.</p> <p>Mode3 : When the camera faces bottom, it rotates 180 ° horizontally and the operating direction of the camera is opposite that of the Tilt operation. However, the operating direction will return to normal 10 seconds after the operation has stopped.</p> <p><b>[Setting value:Off, Digital Flip, Mode1, Mode2, Mode3]</b></p> <p><b>Memo:</b> _____</p> <ul style="list-style-type: none"> <li>● [Intelligent Tracking] is disabled when this is set to “Digital Flip”. (Page 67)</li> <li>● Settings for [Preset Position Speed] are reflected in the rotation speed when images are flipped using “Mode1”, “Mode2”, “Mode3”. To flip images in high speed using “Mode1”, “Mode2”, “Mode3”, set the [Speed] in [Preset Position Speed] to “4”.</li> </ul> <p><b>Note:</b> _____</p> <ul style="list-style-type: none"> <li>● When [Auto Flip] is set to other than “Off”, the camera can be moved to areas outside the pan limit with the Tilt operation. When “Digital Flip” is set, use the Tilt operation to flip and return to the pan limit area again. When “Mode1”, “Mode2” or “Mode3” is set and the camera is moved to inside of the pan limit with Pan operation, it will stop at the pan limit position.</li> </ul>

### Setting (continued)

#### Auto Patrol Page

This function sets the Auto Patrol operation which patrols multiple positions at specified time intervals. You can set the order in which to view the determined positions. This page can be used during access using “admin” or “operator”.

- Click [Advanced Settings] to display setting menu.
- Click [Auto Patrol]. Press the [OK] button to enable the new settings. Press the [OK] button to enable the new settings.
- If the [OK] button is pressed upon entering an invalid value, a warning message will appear and the entry will be denied. Press the [Cancel] button to restore the invalid entry to the current value.

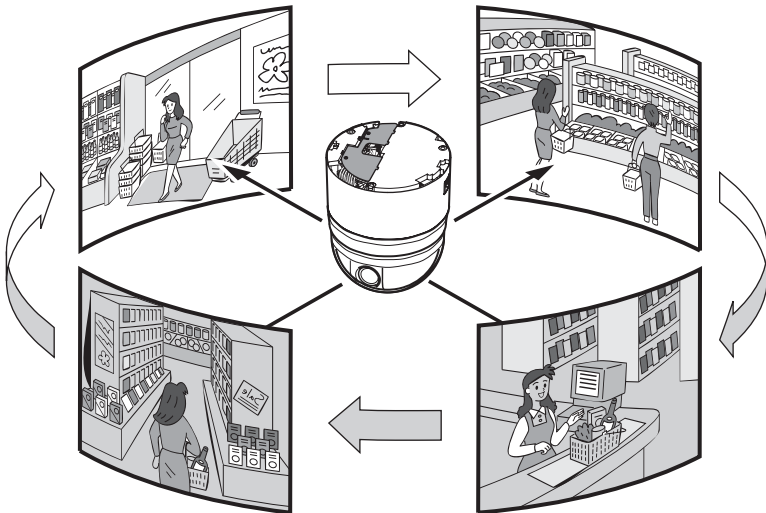

There are three screens in Auto Patrol.

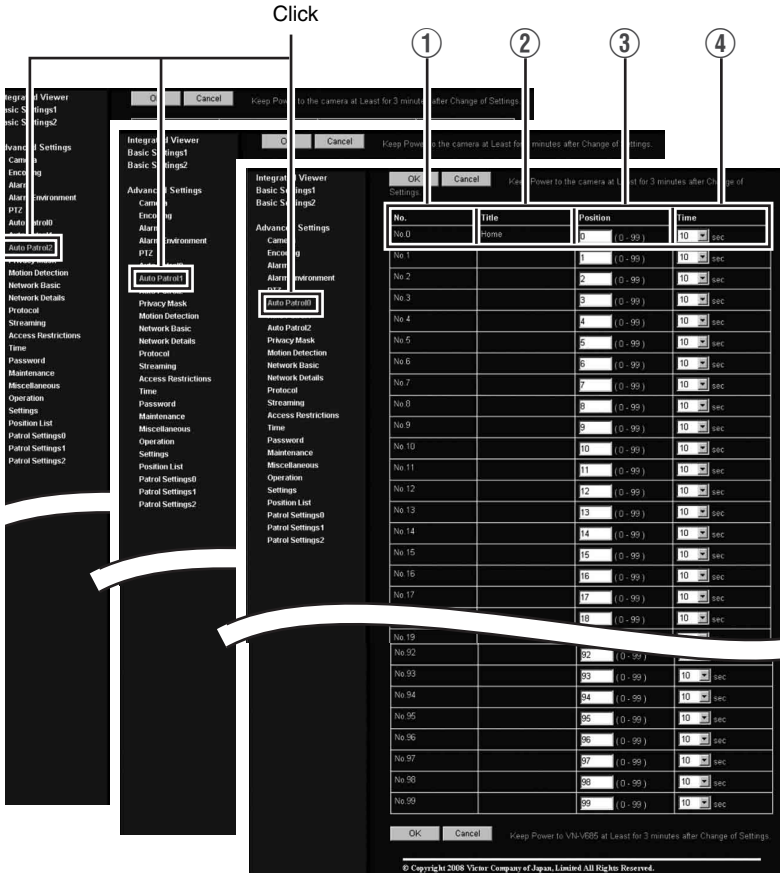

① No	Switches the camera image from No. 0 to 99 in sequence.
② Title	This displays the title of the position.
③ Position	This sets the position number to be moved in sequence. [Setting value:0 to 99]
④ Time	This sets the duration of staying at the position. (Unit: Seconds) [Setting range:Skip, 10 sec, 20 sec, 30 sec, 45 sec, 60 sec, 120 sec]

## Setting (continued)

### Privacy Mask Page

Privacy Mask is a feature that enables masking of a portion of the image. You can set 8 rectangular privacy masks for this unit.

This page can be used during access using “admin” or “operator”.

- Click [Advanced Settings] to display setting menu.
- Click [Privacy Mask]. Press the [OK] button to enable the new settings.
- Press the [OK] button to enable the new settings.

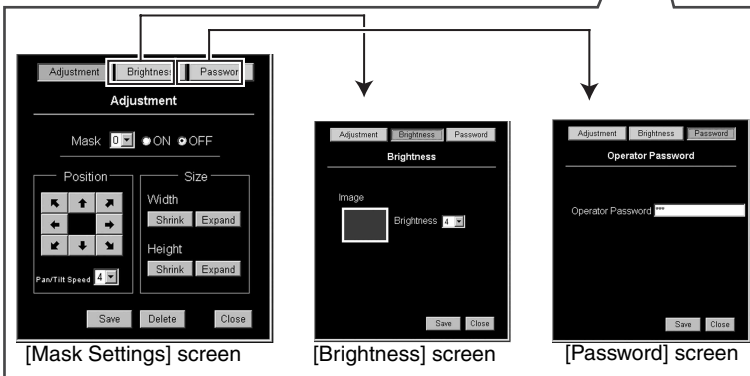
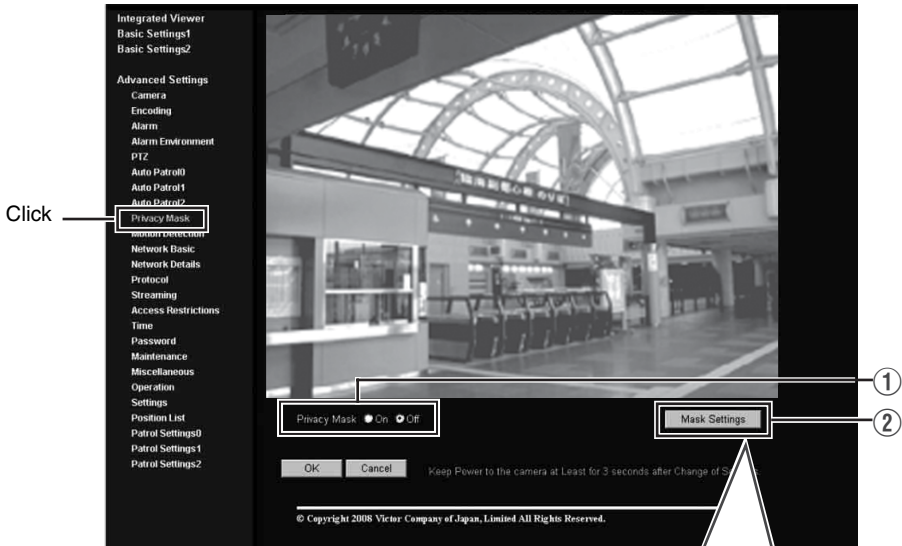

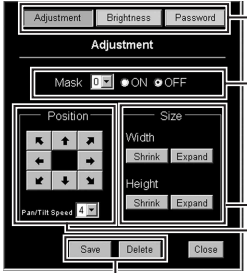
<p>① <b>Privacy Mask</b></p>	<p>For specifying whether to activate the Privacy Mask feature. When this is set to “On”, the privacy mask specified using the following items will appear on the screen.</p> <p><b>Memo:</b></p> <ul style="list-style-type: none"> <li>When setting privacy mask, zoom will be at the Wide edge and [Digital Flip] is set to “Off”.</li> </ul>
<p>② <b>Mask Settings</b></p>	<p>This item adjusts the mask. Click this item to open the [Adjustment] screen. To change the setting, first, enter [Operator Password] in the [Password] screen. (☞ Page 44)</p> <p>If the [Operator Password] was entered already to setting page of built-in viewer, it will be displayed as ●●●●●●.</p> <p>■ <b>[Mask Settings] screen</b></p>  <p>① <b>[Adjustment], [Brightness], [Password] tab</b> Each setting screen appears.</p> <p>② <b>[Mask]</b> When “Off” is selected, mask will not be displayed on the screen. <b>[Setting value:0 to 7]</b></p> <p>③ <b>[Size]</b> This item sets the size of the mask. Use the [Shrink] or [Expand] button to set the “Height” or “Width” of the mask.</p> <p>④ <b>[Position]</b> This sets the position to place the mask. Set the moving speed in [Pan/Tilt Speed]. <b>[Setting values:1 to 8]</b></p> <p>⑤ <b>[Save]</b> This saves the new settings.</p> <p><b>[Delete]</b> This removes the privacy mask of the specified mask number.</p> <p>■ <b>[Brightness] screen</b></p> <p>This item sets the brightness (color) of the mask. “0” is black. The larger the number is, the closer the color is to white. When the number is “10”, the color is white. You can check the color at [Image]. <b>[Setting value:0 to 10]</b></p> <p>■ <b>[Password] screen</b></p> <p>Enter the “Operator Password”. (☞ Page 44)</p>

**Note:**

- The tilt angle where mask can be set is within 40 degrees from the horizontal position.
- To change the privacy mask position to upper area from horizontal direction, press the up button until the end of the horizontal position, release the button, and press it again. Only the privacy mask will be moved to upper area. This will set the privacy mask at the area above the shallow horizontal position.
- The mask will appear larger than when it is set. If some area that you wish to hide appear due to the camera direction or zoom, set the mask larger.
- The default home position is outside the range of the privacy mask.
- When the [Adjustment] window is opened in the computer for the first time, ActiveX will be installed.

## Setting (continued)

### Motion Detection Page

This page is for setting motion detection.

This page can be used during access using “admin” or “operator”.

- Click [Advanced Settings] to display setting menu.
- Click [Motion detection]. Press the [OK] button to enable the new settings.
- The area valid for motion detection is displayed in blue.
- When motion is detected, the image screen edge is displayed in red.
- Information of the configured mask is also applicable for detecting the tracking target of Intelligent Tracking, which starts from Auto Return. (☞ Page 67)

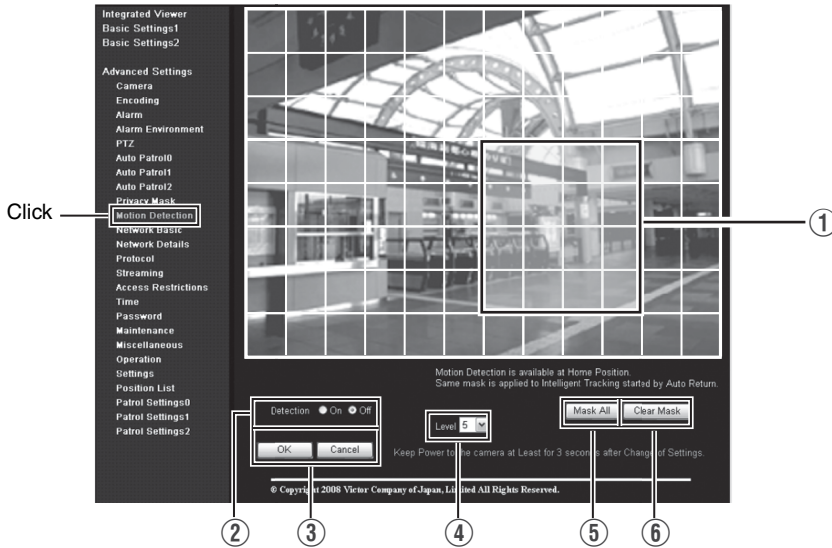



① <b>Display Screen</b>	The screen is divided into blocks of 12 (horizontal) x 8 (vertical). Use this to set whether to mask each block. All blocks are masked in the default setting. The block turns blue when it is clicked, indicating that it is unmasked. Click again to return to the masked state. Press the [OK] button to enable this setting. Use the [Mask All] button to mask all blocks. Use the [Clear Mask] button to unmask all blocks.
② <b>Detection</b>	For setting the On/Off of [Detection]. Press the [OK] button to enable this setting. Motion detection does not work during [Auto Tracking/Intelligent Tracking] (☞ Page 67).
③ <b>OK/Cancel</b>	To apply the new parameters, press the [OK] button. Press the [Cancel] button to cancel the change.
④ <b>Level</b>	For setting the sensitivity of motion detection. Increasing the number raises the detection sensitivity level, and hence it is more sensitive. Press the [OK] button to enable this setting. <b>[Setting value:0 to 10]</b>
⑤ <b>Mask All</b>	Masks all blocks. Press the [OK] button to enable this setting.
⑥ <b>Clear Mask</b>	Unmasks all blocks. Press the [OK] button to enable this setting.

**Memo:**

- The area display position serves as a reference. Make sure to perform operation check.
- The screen is divided into blocks of 96 (12 horizontal x 8 vertical). Set the angle of view such that the size of the object for which motion is to be detected is larger than the size of multiple blocks.
- When [Stabilizer] is set to “On”, the image is zoomed to 1.3 times. Thus, the number of blocks displayed on the motion detection setting screen becomes 48 (8 horizontal x 6 vertical).  
(☞ Page 53)

**Note:**

- Flickers of fluorescent lamps may cause motion detection.
- Changes in brightness due to the light source may be detected as motion.
- The motion detection feature is not intended to prevent theft or fire. This feature may not function properly depending on the conditions of the object and settings.  
Our company shall not be liable for any accident or damage that occurs.
- When other client is getting JPEG/MPEG4 stream from this unit, video images may not appear on the [Motion Detection] page due to the maximum distribution limit of the camera. Stop other clients before using the [Motion Detection] page.

## Setting (continued)

### Network Basic Page

This page is for performing basic setting related to the network.

This page can be used during access using "admin".

- Click [Advanced Settings] to display setting menu.
- Click [Network Basic]. Press the [OK] button to enable the new settings.
- Press the [OK] button to enable the new settings.
- If the [OK] button is pressed upon entering an invalid value, a warning message will appear and the entry will be denied. Press the [Cancel] button to restore the invalid entry to the current value.
- When settings of the Basic page is changed, all services that are currently running will end immediately. For example, when changes are made to the [Network Basic] page during JPEG/MPEG4 distribution, distribution will be discontinued and TCP will be disconnected.

The screenshot shows the 'Network Basic' configuration page. The left sidebar contains a tree view with 'Network Basic' selected. The main area contains the following settings:

- 1: IP Setting (DHCP Enable)
- 2: IP Address (10.66.150.114)
- 3: Subnet Mask (255.255.255.0)
- 4: Default Gateway (10.66.150.254)
- 5: Host Name
- 6: DNS Server (0.0.0.0)
- 7: MAC Address (00:80:88:12:45:66)
- 8: IP Protocol (IP Version 4 selected, IP Version 6 unselected)
- 9: IPv6 Address (link, local, Disabled, global, Disabled)

At the bottom, there is a copyright notice: © Copyright 2008 Victor Company of Japan, Limited All Rights Reserved.

① <b>IP Setting</b>	For setting the DHCP client function. Connect the camera to a network environment with a DHCP server when DHCP is to be enabled. If the DHCP server does not exist when [IP Setting] is set to “DHCP Enable”, the camera will start running with IP address 192.168.0.2 and subnet mask 255.255.255.0 in about 2 minutes after startup. Refer to [IP Address Settings] (☞ Page 36) for the IP address.
② <b>IP Address</b>	For setting the IP address of the camera.
③ <b>Subnet Mask</b>	For setting the subnet mask of the camera.
④ <b>Default Gateway</b>	For setting the default gateway of the camera. Set as “0.0.0.0” when a default gateway is not set.
⑤ <b>Host Name</b>	For setting the host name of the camera. Specify a name using alphanumeric characters, hyphen (-) or period (.). Underscores (_) cannot be used.
⑥ <b>DNS Server</b>	For setting the address of the DNS server.
⑦ <b>MAC Address</b>	The MAC address of the camera is displayed in a hexadecimal number.
⑧ <b>IP Protocol</b>	For setting IPv6 to “On” or “Off”. (IPv4 is set to “On” at all times.) When IPv6 is set to “On” in a network that supports IPv6, the address appears in the [IPv6 Address] field. If the network does not support IPv6, “Disable” appears in the [IPv6 Address] field. Camera will restart if this item is altered. Wait for about one minute before operation of the unit is enabled.
⑨ <b>IPv6 Address</b>	Displays the IPv6 address.

## Setting (continued)

### Network Details Page

This page is for performing detailed network setting.

This page can be used during access using “admin”.

- Click [Advanced Settings] to display setting menu.
- Click [Network Details]. Press the [OK] button to enable the new settings.
- Press the [OK] button to enable the new settings.
- If the [OK] button is pressed upon entering an invalid value, a warning message will appear and the entry will be denied. Press the [Cancel] button to restore the invalid entry to the current value.

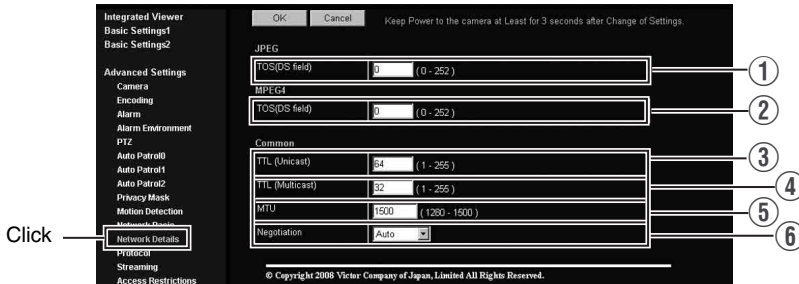

<b>JPEG</b>	
① TOS(DS field)	For setting the TOS value of IP packets in which JPEG is stored. The upper six bits out of the eight bits that make up the TOS value belong to DSCP. This upper six bits can be set. The lower two bits are “0”. For example, upon setting to “255”, the lower two bits are converted to “0”, and the value becomes “252”. TOS values are used in networks that support QoS. By setting QoS for the network switch, routing can be done by giving priority to packets with a larger TOS value.
<b>MPEG4</b>	
② TOS(DS field)	For setting the TOS value of IP packets in which MPEG4 is stored. For details, refer to the [JPEG TOS(DS field)] item ① above.
<b>Common</b>	
③ TTL (Unicast)	For setting the TTL value of JPEG/MPEG4 packets that are to be sent via TCP.
④ TTL (Multicast)	For setting the TTL value of JPEG/MPEG4 packets that are to be sent via multicast.
⑤ MTU	For setting the maximum packet size for storing JPEG/MPEG4. <b>[Setting range:1280 to 1500]</b>
⑥ Negotiation	For setting the [Negotiation] of the [Network Details]. When a value other than “Auto” is selected, do not set the network device to be connected to “Auto”. Ensure that it is set to the same value as the camera.

## Protocol Page

This page is for changing the HTTP server port number.

This page can be used during access using “admin”.

- Click [Advanced Settings] to display setting menu.
- Click [Protocol]. Press the [OK] button to enable the new settings.
- Press the [OK] button to enable the new settings.
- After changing, you will need to re-establish the connection if you are using the Internet Explorer.

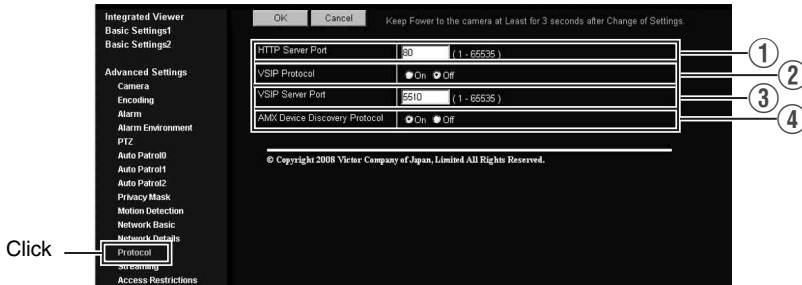

<p>① <b>HTTP Server Port</b></p>	<p>You can change the port number for the built-in web server of the camera. (1-65535) The default port number setting is “80”. The port number of JPEG/MPEG4 server is changed also. To access to camera from the Internet Explorer, enter the following in the Internet Explorer when the camera is in its default settings. http://192.168.0.2 If the port number is changed to “8080”, for example, enter the Internet Explorer as follows. http://192.168.0.2:8080</p>
<p>② <b>VISIP Protocol</b></p>	<p>You can change the On/Off setting of VSIP Protocol. To use this unit from Nextiva of Verint Systems Inc., select “On”.</p>
<p>③ <b>HTTP Server Port</b></p>	<p>You can change the port number for Built-in VSIP server of the camera. (1-65535) The default port number setting is “5510”.</p>
<p>④ <b>AMX Device Discovery Protocol</b></p>	<p>You can change the On/Off setting of AMX device detection protocol. Set to “On” when you are using the camera on AMX’s systems. <b>[Setting value:On , Off]</b></p>

### Memo:

- If Built-in Viewer is used for playback, change the [HTTP Port] number in the setting screen of Built-in Viewer to the same value. (Page 119) (Page 121)

## Setting (continued)

### Streaming Page

This page is for setting manual multicast transmission.

This page can be used during access using “admin” or “operator”.

- Click [Advanced Settings] to display setting menu.
- Click [Streaming]. Press the [OK] button to enable the new settings.
- Press the [OK] button to enable the new settings.
- If the [OK] button is pressed upon entering an invalid value, a warning message will appear and the entry will be denied. Press the [Cancel] button to restore the invalid entry to the current value.

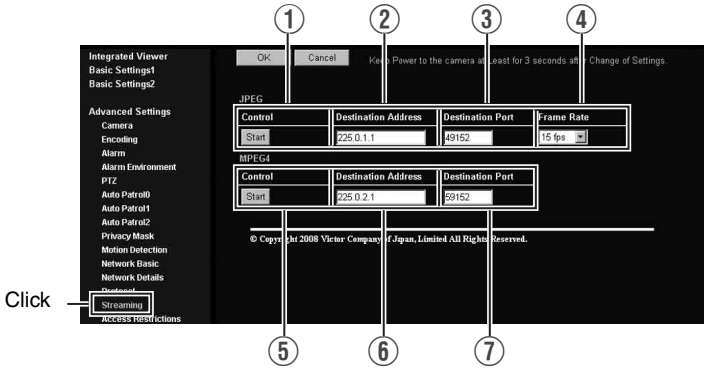

<b>JPEG</b>	
① <b>Control</b>	For starting or stopping streaming of JPEG images. Parameters that are set on the [Streaming] page will be saved when transmission is started upon pressing the [Start] button.
② <b>Destination Address</b>	For specifying the destination address of JPEG streaming. Specify the multicast address. When other devices that make use of multicast transmission exist, ensure that each of them is set to a different multicast address.
③ <b>Destination Port</b>	For specifying the destination port number of JPEG streaming. Specify an even number for RTP compliance. When other devices that make use of multicast transmission exist, it is recommended that each of them be set to a different port number. Multiple multicast streams cannot be received on a single computer when there are duplicate port numbers.
④ <b>Frame Rate</b>	For specifying the frame rate when sending JPEG images via multicast.
<b>MPEG4</b>	
⑤ <b>Control</b>	For starting or stopping streaming of MPEG4 images. Parameters that are set on the [Streaming] page will be saved when transmission is started upon pressing the [Start] button.
⑥ <b>Destination Address</b>	For specifying the destination address for MPEG4 streaming. Specify the multicast address. When other devices that make use of multicast transmission exist, ensure that each of them is set to a different multicast address.
⑦ <b>Destination Port</b>	For specifying the destination port number for MPEG4 streaming. Specify an even number for RTP compliance. When other devices that make use of multicast transmission exist, it is recommended that each of them be set to a different port number. Multiple multicast streams cannot be received on a single computer when there are duplicate port numbers.

**Memo:** \_\_\_\_\_

- When the power of the camera is turned off accidentally during multicast transmission, multicast transmission will restart automatically after the camera is rebooted.

## Setting (continued)

### Access Restrictions Page

This page is for setting client restrictions.

This page can be used during access using "admin".

- Click [Advanced Settings] to display setting menu.
- Click [Access Restrictions]. Press the [OK] button to enable the new settings.
- Press the [OK] button to enable the new settings.
- If the [OK] button is pressed upon entering an invalid value, a warning message will appear and the entry will be denied. Press the [Cancel] button to restore the invalid entry to the current value.
- This feature is targeted at JPEG/MPEG4 acquisition. It does not impose restrictions on access via a web browser or use of API.

#### Note:

- The Access Restriction feature determines whether to impose restrictions during TCP connection by the client. In the case when access restriction is set after TCP connection by a client has been established, TCP connection will not be disconnected.

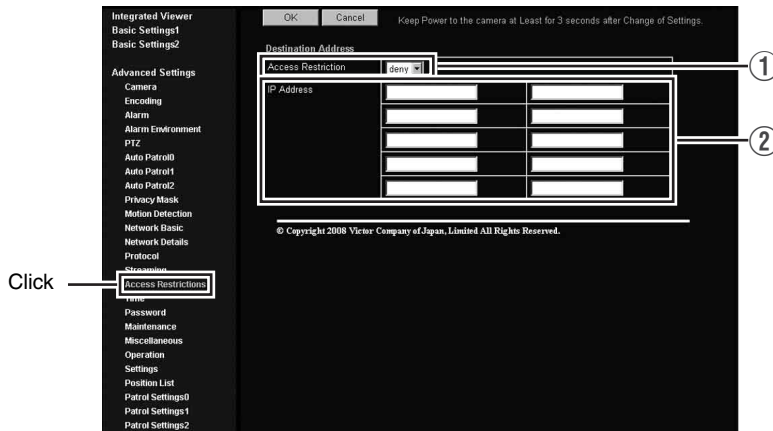



<b>Destination Address</b>	Restrictions may be imposed on clients accessing the camera using the IP address.
① <b>Access Restrictions</b>	When “deny” is selected, acquisition of JPEG/MPEG4 via the IP address specified for the [IP Address] item ② will be denied. Restrictions are not imposed on access to the Web Settings page. When “allow” is selected, acquisition of JPEG/MPEG4 via the IP address specified for the [IP Address] item ② will be permitted. Restrictions are not imposed on access to the Web Settings page.
② <b>IP Address</b>	When a multicast address is specified and “deny” is selected, the camera will deny transmission to this multicast address. When a multicast address is specified and “allow” is selected, the camera will only accept transmission to this multicast address and deny transmission to multicast addresses that are not stated in the [IP Address] item ② field.

**Note:**

- Note that when “allow” is selected and all IP address fields are left blank, JPEG/MPEG4 acquisition by all IP addresses will be denied. Restrictions are not imposed on access to the Web Settings page.

Additionally, the camera will also deny access when instructions for transmission to the specified IP address are sent via API.

**Memo:**

- To specify a specific IP address range, enter a combination of the IP address and subnet mask in the [IP Address] item ② field.
- Define the subnet mask using a length between 8 to 30 bits.  
For example, a range between 192.168.0.0 to 192.168.0.255 is denoted as 192.168.0.0/24 ([IP Address]/[bit length of subnet mask]).

## Setting (continued)

### Time Page

This page is for setting time.

This page can be used during access using “admin”.

- Click [Advanced Settings] to display setting menu.
- Click [Time]. Press the [OK] button to enable the new settings.
- Press the [OK] button to enable the new settings.
- If the [OK] button is pressed upon entering an invalid value, a warning message will appear and the entry will be denied. Press the [Cancel] button to restore the invalid entry to the current value.

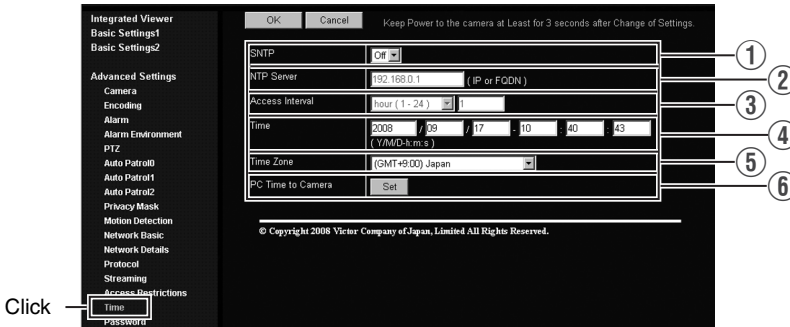

① <b>SNTP</b>	For setting the SNTP client feature. When this is set to “On”, the system accesses the specified NTP server at regular intervals to acquire the time. In addition, time will be recorded in the JPEG headers distributed by the camera. Discontinuity in JPEG header’s time may occur immediately before and after acquiring time from the NTP server.
② <b>NTP Server</b>	For setting the IP address of the NTP server.
③ <b>Access Interval</b>	For setting the time interval for access to the NTP server.
④ <b>Time</b>	Displays the time on the clock of the camera. The clock time can be changed by entering an appropriate value. (Second value cannot be specified.) In addition, time will be recorded in the JPEG headers distributed by the camera. Discontinuity may occur in the JPEG header’s time immediately before and after changing the time.
⑤ <b>Time Zone</b>	For setting the time zone.
⑥ <b>PC Time to Camera</b>	Click [Set] to load the clock time of the computer in use on the camera.

---

## Password Page

This page is for setting the password.

This page can be used during access using “admin”.

- Click [Advanced Settings] to display setting menu.
- Click [Password]. Press the [OK] button to enable the new settings.
- Press the [OK] button to enable the new settings.

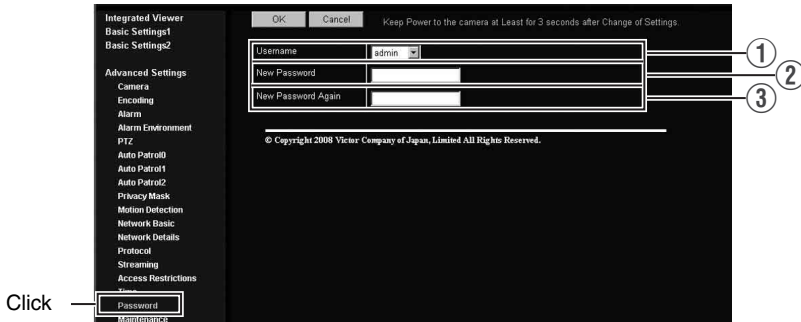

① Username	Select a user name.
② New Password	Enter a new password. Passwords should be 8 characters or less (no space allowed). Camera is case-sensitive.
③ New Password Again	Enter again to confirm the new password.

**Note:**

- Be sure to handle the password carefully in case you forget it.
  - If you have forgotten the password, please consult your nearest JVC dealer.
-

## Setting (continued)

### Maintenance Page

This page is for maintenance purposes.

This page can be used during access using "admin".

- Click [Advanced Settings] to display setting menu.
- Click [Maintenance]. Press the [OK] button to enable the new settings.

Click → Maintenance

1 Restart

2 Initialize

3 Update

4 On Off

5 Apply

Keep Power to the camera during Version Up.  
Before updating, please stop all accesses to the camera except this page.

© Copyright 2008 Victor Company of Japan, Limited All Rights Reserved

① <b>Restart</b>	Reboots the camera. (It takes about one minute for the camera to reboot.)
② <b>All Settings</b> [Initialize]	Restores all settings to their default values and reboots the unit. (It takes about one minute for the camera to initialize and reboot.) Passwords will also be initialized. The built-in clock of the camera will not be affected. JPEG/MPEG4 transmission and all other services that are running will be discontinued.
③ <b>Update</b>	<p>Upgrades the firmware version of the camera and reboots the unit. Select the update target from [Streaming Manager], [PTZ Controller] or [Image Processor].</p> <p>The settings of the camera will be saved. Copy the new firmware file to the computer on which Internet Explorer is used, and specify this file using the [Browse...] button. Press the [Update] button to start the update. JPEG/MPEG4 transmission and all other services that are running will be discontinued. The update process may take several minutes.</p> <p>A message will be displayed on the Internet Explorer when update is successfully completed.</p> <p><b>Note:</b> _____</p> <ul style="list-style-type: none"> <li>● Do not turn off the power when update is in progress or during reboot after update is complete. Turning off the power of the camera may cause it to malfunction.</li> <li>● Before updating, end all accesses to the camera (such as viewer) other than from this page. If there are accesses from other pages, when update starts, the access from this page may be disconnected. In this case, end all the accesses from other pages, then access this page and try updating again.</li> </ul>
④ <b>Auto Cleaning</b>	<p>This item sets whether to automatically clean the power and signal transmission components.</p> <p><b>Note:</b> _____</p> <ul style="list-style-type: none"> <li>● When the camera has stopped at the pan position for more than 7 days, it will pan at the specified time and perform cleaning automatically.</li> </ul>
⑤ <b>Auto Cleanig Time</b>	<p>This item sets the time to start cleaning. To change the setting, enter the time and click the [Apply] button.</p> <p><b>[Setting values:0-23 h, 0-59 m]</b></p>

## Setting (continued)

### List of Factory Settings of Each Page

#### ■ Camera Page (Page 51)

Item	Factory Settings
Camera ID	“VN-V685” (For VN-V685U)  “VN-V686” (For VN-V686BU/ VN-V686WPBU)
Monitor Type	Custom
Black Level	1
Gamma	1
Active Gamma Level	0
Enhance Frequency	High
Enhance Level	0
Color Level	0
Stabilizer	Off
Stabilizer Level	Mid
Noise Reduction	Off
AGC	High
Sense Up	Off
ALC Priority	Motion
Shutter Speed	1/60
B/W Mode	Color
IR Preset AF	Off
Light	Normal

#### ■ Encoding Page (Page 56)

Item	Factory Settings
JPEG Frame Size	VGA
MPEG4 Frame Size	VGA
JPEG Quality	VFS4
MPEG4 Bitrate	2000 kbps
MPEG4 Bitrate Control	CBR
MPEG4 FPS	15 fps
MPEG4 I Frame Interval	30
MPEG4 Priority	FPS

#### ■ Alarm Page (Page 58)

Item	Factory Settings
Action	Disable
1st Trigger	Input 1 Make
Max. Interval	—
2nd Trigger	Disable
Action Position No.	—
Trigger Position No.	—
Mail Address	—
Mail Text	
Attach Image	Off
TCP/UDP IP Address	—
TCP/UDP Port Number	—
TCP/UDP Data	—
Alarm Output Duration	—
Time Filter	Unmask All

■ Alarm Environment Page(☞ Page 62)

Item	Factory Settings
SMTP Server	0.0.0.0
Port Number	25
Send Mail Address	—
POP before SMTP	Off
POP Server	0.0.0.0
Port Number	110
Username	—
Password	—
FTP Server	0.0.0.0
Directory	—
Username	—
Password	—
Periodic FTP	Off
Periodic FTP Interval	1
Periodic FTP Time Filter	Auto
Periodic FTP Time Filter	Unmask All
PrePostRecording Frame Rate	15 fps
PrePostRecording Before Trigger	5 sec
PrePostRecording After Trigger	5 sec
Duration Output1	1000 msec
Duration Output2	1000 msec
Manual Output Output1	Break
Manual Output Output2	Break

■ PTZ Page(☞ Page 66)

Item	Factory Settings
Mode	none
Return Time	1 minute
Restart Time	Off
Auto Tracking Level	5
Tracking Zoom	On
Tracking Zoom Limit	5 Times
EZoom Limit	2
Pan Limit	Off
Tilt Limit	0 degree
Preset Position Speed	4
Auto Flip	Digital Flip

## Setting (continued)

### List of Factory Settings of Each Page (continued)

#### ■ Auto Patrol Page (Page 72)

Item	Factory Settings
Position	(Preset Position number)
Time	10

#### ■ Privacy Mask Page (Page 74)

Item	Factory Settings
Privacy Mask	Off
Mask 0 to 7	Off
Brightness	4
Password	—

#### ■ Motion Detection Page (Page 76)

Item	Factory Settings
Mask	Clear Mask
Detection	Off
Level	5

#### ■ Network Basic Page (Page 78)

Item	Factory Settings
IP Setting	DHCP Enable
IP Address	192.168.0.2
Subnet Mask	255.255.255.0
Default Gateway	192.168.0.254
Host Name	—
DNS Server	0.0.0.0
IP Protocol	IP version4 IP version6
IPv6 Address	Disable

#### ■ Network Details Page (Page 80)

Item	Factory Settings
JPEG TOS	0
MPEG4 TOS	0
TTL (Unicast)	64
TTL (Multicast)	32
MTU	1500
Negotiation	Auto

#### ■ Protocol Page (Page 81)

Item	Factory Settings
HTTP Server Port	80
VSIP Protocol	Off
VSIP Server Port	5510
AMX Device Discovery Protocol	On



## ■ Streaming Page(☞ Page 82)

Item	Factory Settings
JPEG Destination Address	225.0.1.1
JPEG Destination Port	49152
JPEG Frame Rate	15 fps
MPEG4 Destination Address	225.0.2.1
MPEG4 Destination Port	59152

## ■ Access Restrictions Page (☞ Page 84)

Item	Factory Settings
Access Restrictions	deny
IP Address	—

## ■ Time Page(☞ Page 86)

Item	Factory Settings
SNTP	Off
NTP Server	0.0.0.0
Access Interval	hour,1
Time Zone	(GMT)UTC

## ■ Password Page(☞ Page 87)

Item	Factory Settings
Username	“admin”
Current Password	Blank Default passwords are: “admin” : jvc “operator” : jvc “user” : jvc

## Setting (continued)

### Miscellaneous page

This page is for acquiring information.

This page can be used during access using “admin”, “operator” and “user”.

- Click [Advanced Settings] to display setting menu.
- Click [Miscellaneous]. Press the [OK] button to enable the new settings.

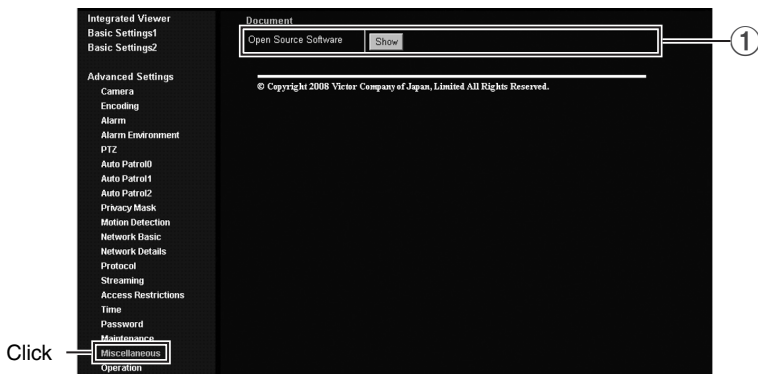

### ① Open Source Software

Press the [Show] button to display information of the software used by the camera.

## Operation Page

Displays the operating status of the camera.

This page can be used during access using “admin” or “operator”.

- Click [Advanced Settings] to display setting menu.
- Click [Operation]. Press the [OK] button to enable the new settings.

© Copyright 2008 Victor Company of Japan, Limited. All Rights Reserved.

Operation	
① <b>Total Sending Bitrate</b>	Displays the total TCP/UDP bit rate sent by the camera as well as the individual bit rates.
② <b>Destination</b>	Displays the destination that the camera is sending data to.
Log	
③ <b>System Log</b>	Displays the following information. <ul style="list-style-type: none"> <li>• Number of seconds after startup</li> <li>• Alarm information</li> </ul>

## Setting (continued)

### Settings Page

This page displays the version information and settings of the camera.

This page can be used during access using “admin” or “operator”.

- Click [Advanced Settings] to display setting menu.
- Click [Settings]. Press the [OK] button to enable the new settings.

Click

Integrated Viewer  
Basic Settings1  
Basic Settings2  
Advanced Settings  
Camera  
Encoding  
Alarm  
Alarm Environment  
PTZ  
Auto Patrol0  
Auto Patrol1  
Auto Patrol2  
Privacy Mask  
Motion Detection  
Network Basic  
Network Details  
Protocol  
Streaming  
Access Restrictions  
Time  
Password  
Maintenance  
Miscellaneous  
Operation  
**Settings**  
Position List  
Patrol Settings0  
Patrol Settings1  
Patrol Settings2

Revision

Streaming Manager	0.05
PTZ Controller	0.02
Image Processor	ES-95
Lens	19

Camera

Camera ID	VN-V685
Monitor Type	Custom
Black Level	1
Gamma	1
Active Gamma Level	0
Enhance Frequency	High
Enhance Level	0
Color Level	0
Stabilizer	Off
Stabilizer Level	Mid
Noise Reduction	Off
AGC	High
Sense Up	Off
ALC	Motion
Shutter Speed	1/60
B&W Mode	Color
IR Preset AF	Off
Light	Normal

Encoding

Frame Size	JPEG	MPEG4
	VGA	VGA

JPEG

Quality	VFS1
Size	80 KB

MPEG4

Bitrate	2000 kbps
Bitrate Control	CBR
FPS	15 fps
I Frame Interval	30 frames
Priority	FPS

Alarm Setting

No.	Trigger / Action	
01	Trigger	-----
	Action	Off
02	Trigger	-----
	Action	Off
03	Trigger	-----
	Action	Off
04	Trigger	-----
	Action	Off
05	Trigger	-----
	Action	Off

<b>JPEG</b>	
Quality	VFS1
Size	80 kB

<b>MPEG4</b>	
Bitrate	2000 kbps
Bitrate Control	CBR
FPS	15 fps
1 Frame Interval	30 frames
Priority	FPS

**Alarm Setting**

No.	Trigger / Action
01	Trigger -----
	Action Off
02	Trigger -----
	Action Off
03	Trigger -----
	Action Off
04	Trigger -----
	Action Off
05	Trigger -----
	Action Off

**Alarm Environment**

Mail	SMTP (SMTP Server: 0.0.0.0) SMTP (Port Number: 25) Send Mail Address: SMTP (POP before SMTP: Off) POP (POP Server: 0.0.0.0) POP (Port Number: 110) POP (Username: )
FTP	FTP Server: 0.0.0.0 Directory: Username: Periodic FTP: Off Periodic FTP Interval: 1 Periodic FTP Naming: Auto PrePostRecording Frame Rate: 15 fps PrePostRecording Before Trigger: 5 sec PrePostRecording After Trigger: 5 sec
Alarm Output	Output1 Duration: 1000 msec Output2 Duration: 1000 msec

**PTZ**

<b>Auto Return</b>	
Mode	None
Return Time	1 minutes

<b>Auto Tracking / Intelligent Tracking</b>	
Restart Time	Off
Auto Tracking Level	5

<b>Intelligent Tracking</b>	
Tracking Zoom	On
Tracking Zoom Limit	10 Times

<b>Limit</b>	
EZoom Limit	2
Pan Limit	Off
Tilt Limit	0 Degrees

<b>Preset Position Speed</b>	
Speed	4

<b>Auto Flip</b>	
Auto Flip	Digital Flip

## Setting (continued)

### Settings Page (continued)

Motion Detection	
Detection	Off
Level	5
Mask Area	FFFFFFFFFFFFFFFFFFFFFF

Network Basic	
IP Address	10.66.150.113
Subnet Mask	255.255.255.0
Default Gateway	10.66.150.254
Host Name	
DNS Server	0.0.0.0
MAC Address	00:80:88:43:1f:34
IP Protocol	<input checked="" type="checkbox"/> IP Version 4 <input type="checkbox"/> IP Version 6
IPv6 Address	Ink local Disabled global Disabled

Network Details	
<b>JPEG</b>	
TOS:(OS field)	0
<b>MPEG4</b>	
TOS:(OS field)	0
<b>Common</b>	
TTL (Unicast)	64
TTL (Multicast)	32
MTU	1500
Negotiation	Auto

Protocol	
HTTP Server Port	80
VSIIP Protocol	On
VSIIP Server Port	5010
AMX Device Discovery Protocol	On

Streaming	
<b>JPEG</b>	
Status	-----
Address	225.0.1.1
Port	49152
Frame Rate	15
<b>MPEG4</b>	
Status	-----
Address	225.0.2.1
Port	59152

Access Restriction	
Access Restriction	deny
IP Address	

Time	
SNTP	SNTP: Off NTP Server: 192.168.0.1 Access Interval: 1 hour
Time / Time Zone	Time: 2008/09/22 - 16:11:20 (Y/M/D:h:m:s) Time Zone: (GMT+9:00) Japan

© Copyright 2008 Yamanashi Company of Japan, Limited. All Rights Reserved.

## Position List Page

This page displays information on preset positions.

This page can be used during access using “admin” or “operator”.

- Click [Advanced Settings] to display setting menu.
- Click [Position List]. Press the [OK] button to enable the new settings.

Click →

Position	Registration	Title
No.0	Registered	Home
No.1	Unregistered	
No.2	Unregistered	
No.3	Unregistered	
No.4	Unregistered	
No.5	Unregistered	
No.6	Unregistered	
No.7	Unregistered	
No.8	Unregistered	
No.9	Unregistered	
No.10	Unregistered	
No.11	Unregistered	
No.12	Unregistered	
No.13	Unregistered	
No.14	Unregistered	
No.15	Unregistered	
No.16	Unregistered	
No.17	Unregistered	
No.18	Unregistered	
No.19	Unregistered	
No.20	Unregistered	
No.21	Unregistered	
No.22	Unregistered	
No.23	Unregistered	
No.24	Unregistered	
No.25	Unregistered	
No.26	Unregistered	
No.27	Unregistered	
No.28	Unregistered	
No.29	Unregistered	
No.30	Unregistered	
No.31	Unregistered	
No.32	Unregistered	
No.33	Unregistered	
No.34	Unregistered	
No.35	Unregistered	
No.36	Unregistered	
No.37	Unregistered	
No.38	Unregistered	
No.39	Unregistered	
No.40	Unregistered	
No.41	Unregistered	
No.42	Unregistered	
No.43	Unregistered	
No.44	Unregistered	
No.45	Unregistered	
No.46	Unregistered	
No.47	Unregistered	
No.48	Unregistered	
No.49	Unregistered	
No.50	Unregistered	
No.51	Unregistered	
No.52	Unregistered	
No.53	Unregistered	
No.54	Unregistered	
No.55	Unregistered	
No.56	Unregistered	
No.57	Unregistered	
No.58	Unregistered	
No.59	Unregistered	
No.60	Unregistered	
No.61	Unregistered	
No.62	Unregistered	
No.63	Unregistered	
No.64	Unregistered	
No.65	Unregistered	
No.66	Unregistered	
No.67	Unregistered	
No.68	Unregistered	
No.69	Unregistered	
No.70	Unregistered	
No.71	Unregistered	
No.72	Unregistered	
No.73	Unregistered	
No.74	Unregistered	
No.75	Unregistered	
No.76	Unregistered	
No.77	Unregistered	
No.78	Unregistered	
No.79	Unregistered	
No.80	Unregistered	
No.81	Unregistered	
No.82	Unregistered	
No.83	Unregistered	
No.84	Unregistered	
No.85	Unregistered	
No.86	Unregistered	
No.87	Unregistered	
No.88	Unregistered	
No.89	Unregistered	
No.90	Unregistered	
No.91	Unregistered	
No.92	Unregistered	
No.93	Unregistered	
No.94	Unregistered	
No.95	Unregistered	
No.96	Unregistered	
No.97	Unregistered	
No.98	Unregistered	
No.99	Unregistered	

© Copyright 2008 Victor Company of Japan, Limited All Rights Reserved.

## Setting (continued)

### Patrol Settings Page

This page displays the information and settings of Auto Patrol.

This page can be used during access using "admin" or "operator".

- Click [Advanced Settings] to display setting menu.
- Click [Patrol Information]. Press the [OK] button to enable the new settings.

Click

No.	Title	Position	Time
No.0	Home	0	10 sec
No.1		1	10 sec
No.2		2	10 sec
No.3		3	10 sec
No.4		4	10 sec
No.5		5	10 sec
No.6		6	10 sec
No.7		7	10 sec
No.8		8	10 sec
No.9		9	10 sec
No.10		10	10 sec
No.11		11	10 sec
No.12		12	10 sec
No.13		13	10 sec
No.14		14	10 sec
No.15		15	10 sec
No.16		16	10 sec
No.17		17	10 sec
No.18		18	10 sec
No.19		19	10 sec
No.20		20	10 sec
No.21		21	10 sec
No.22		22	10 sec
No.23		23	10 sec
No.24		24	10 sec
No.25		25	10 sec
No.73		73	10 sec
No.74			
No.75			
No.76		76	10 sec
No.77		77	10 sec
No.78		78	10 sec
No.79		79	10 sec
No.80		80	10 sec
No.81		81	10 sec
No.82		82	10 sec
No.83		83	10 sec
No.84		84	10 sec
No.85		85	10 sec
No.86		86	10 sec
No.87		87	10 sec
No.88		88	10 sec
No.89		89	10 sec
No.90		90	10 sec
No.91		91	10 sec
No.92		92	10 sec
No.93		93	10 sec
No.94		94	10 sec
No.95		95	10 sec
No.96		96	10 sec
No.97		97	10 sec
No.98		98	10 sec
No.99		99	10 sec



### Built-in Viewer

This product comes with a built-in integrated viewer.

The built-in viewer is activated by entering an IP address into the Internet Explorer. The built-in viewer enables monitoring and PTZ operation to be done in either JPEG or MPEG4 formats.

■ **Using the compressed JPEG format enables display of a series of still images as well as one-shot recording of still images.**

■ **Using the compressed MPEG4 format enables display of MPEG4-encoded motion images.**

- ◆ “Operation” (☞Page102)
- ◆ “Image quality setting” (☞Page104)
- ◆ “PTZ Setting” (☞Page107)
- ◆ “PTZ Control” (☞Page113)
- ◆ “JPEG Viewer Settings” (☞Page118)
- ◆ “MPEG4 Viewer Settings” (☞Page120)
- ◆ “Exiting the Viewer” (☞Page123)

**When the display or configuration of the opened screen appears strange, check the computer settings using the following procedures.**

- ① Click [Start]–[Control Panel]–[Display] and open the [Display Properties] window
- ② Click the [Settings] tab in the [Display Properties] window and click the [Advanced] button
- ③ Check that [DPI setting] in the [General] tab has become [Normal size(96DPI)]
- ④ Otherwise, change the setting to [Normal size(96DPI)] and reboot Windows

## Built-in Viewer (continued)

### Screen Configuration of Built-in Viewer

- When the JPEG Viewer is first installed, it is set to play back at 15 fps by default.



① <b>MENU OFF</b> <b>MENU ON</b>	For showing/hiding the operation menu.
② <b>Control</b>	Switches to the PTZ menu. Click this button when you want to perform “Image Settings”, “PTZ setting” or “PTZ Control”. (☞ Page 104)
③ <b>Viewer Setup</b>	Switches to the viewer settings menu. Click this button when you want to configure the settings of “JPEG Viewer Settings”, “MPEG4 Viewer Settings” or “Operator Password”.
④ <b>Capture</b>	<p>Captures the currently displayed image on the computer. The captured data is recorded as a JPEG file in the folder that is created under [My Documents] of the computer. The default folder name is “VN-V685” (VN-V685U) or “VN-V686B” (VN-V686BU/VN-V686WPBU). The file name is made up of the year, month, day, hour, minute, second, and millisecond.</p> <p><b>Memo:</b></p> <ul style="list-style-type: none"> <li>In the case of Windows Vista, images are stored under [Document].</li> <li>The folder name can be changed. (☞ Page 119)</li> <li>The time indicated is the computer’s clock time, not the clock “Time” of the camera.</li> <li>Motion images cannot be captured.</li> <li>MPEG4 images cannot be captured.</li> </ul>

⑤ <b>Stop</b>	Pauses/Resumes playback of images.
⑥ <b>Compression</b>	Switches the stream to acquire. You can specify either JPEG or MPEG4.
⑦ <b>Display Size</b>	<p>For specifying the display size of the image area.</p> <p>[Fixed] : Display according to the window size of the browser.  [Variable] : Display according to the specified frame size.</p> <p><b>Memo:</b> _____</p> <ul style="list-style-type: none"> <li>• The window size of the browser does not change when [Fixed] or [Variable] is selected.</li> </ul>
⑧ <b>Details</b>	Starts up the page for configuring the various detailed settings.

**Memo:** \_\_\_\_\_

- The settings of Built-in Viewer are stored in the file named Cookie.

This setting screen is used to set Built-in Viewer as a software on the computer, and does not apply to settings of the camera unit.  
When settings are changed, press the [OK] button to exit and restart the Built-in Viewer.

■ **Searching and deleting cookie files**

- Open [Tool]–[Internet Options]–[Advanced] of the Internet Explorer, and press the [Settings] button under [Temporary Internet Files]. A new [Settings] will appear. Press the [View Files] button in this window. The [Temporary Internet Files] window opens up and a list of files will be displayed. The file named “cgi-bin” in this list is the Cookie for the Built-in Viewer.
- Deleting this file deletes the view settings, and the viewer will be initialized during the next startup.

## Built-in Viewer (continued)

### Image quality setting

#### ■ Image Settings

For adjusting the picture quality.

- When a different menu is currently being displayed, click [Control] to switch the menu.
- Click each menu bar on the left of the screen to open the setting screen.

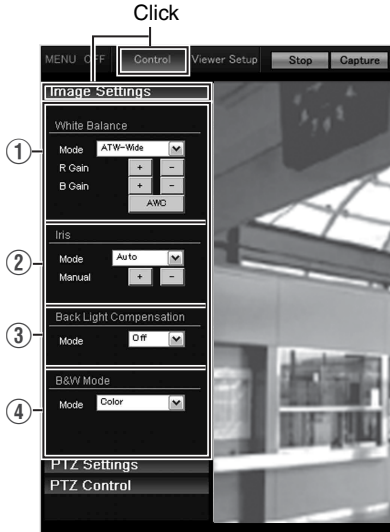

① <b>White Balance</b>	For selecting the white balance control feature.
<b>Mode</b>	<p><b>ATW-Wide</b> : This is the Auto-Tracking White Balance mode (Automatic color temperature tracking). The camera adjusts the white balance automatically according to the color temperature of the illumination. (Color temperature range of 2,300K to 10,000K)</p> <p><b>ATW-Narrow</b> : This mode supports a narrower range of color temperature than ATW-Wide.(Color temperature range of 3,200K to 8,000K)</p> <p><b>ATW-Full</b> : ATW is performed in a wider color temperature range.</p> <p><b>ATW-Sodium</b> : Under the light of a high-pressure sodium lamp, the color is closer to the actual one.</p> <p><b>AWC</b> : Switches to the Auto-White Balance Control mode. In the “AWC” mode, values entered for the [R Gain] and [B Gain] items are applied to white balance.</p>
<b>R Gain</b>	<p>Adjusts the R (red) hue during AWC.</p> <p>[+] : Increases the redness or red level.</p> <p>[-] : Decreases the redness or red level.</p> <p><b>Memo:</b> _____</p> <ul style="list-style-type: none"> <li>• Click the [+] or [-] button once to change to the next value. To change the value continuously, click repeatedly. The value will not change if the button remains pressed down.</li> </ul>

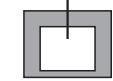
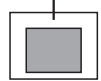
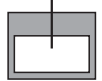
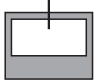
<b>① White Balance (continued)</b>	
<b>B Gain</b>	<p>Adjusts the B (blue) hue during AWC.</p> <p>[+] : Increases the blueness or blue level.          [-] : Decreases the blueness or blue level.</p> <p><b>Memo:</b></p> <ul style="list-style-type: none"> <li>Click the [+] or [-] button once to change to the next value. To change the value continuously, click repeatedly. The value will not change if the button remains pressed down.</li> </ul>
<b>[AWC]button</b>	<p>Executes AWC (automatic white balance control). Execute by placing a white object around the center of the screen in a location with a lighting condition that is similar to the object to be shot.</p> <ul style="list-style-type: none"> <li>Pressing the [AWC] button replaces the [R Gain] and [B Gain] values with the values of the AWC execution results.</li> <li>Even when [White Balance] is set to "ATW-Narrow", "ATW-Wide", pressing the [AWC] button switches the mode automatically to AWC.</li> </ul>
<b>② Iris</b>	
	This item sets the iris.
<b>Mode</b>	When Auto -1, Auto, or Auto +1 is selected, the iris is adjusted automatically.
<b>Manual</b>	You can also adjust using the [+] and [-] buttons. In this case, the iris will change while the button is being pressed. It will stop when the button is released.
<b>③ Back Light Compensation</b>	
	<p>For selecting the backlight compensation feature. Set this feature when there is a bright light source in the same direction as the object. Enables unwanted light sources to be excluded from the photometry area.</p>
<b>Mode</b>	<p>Off : No backlight compensation.          Area1 to Area4 : For selecting a photometry area from the four available types.</p> <p><b>[Setting value: Off, Area1, Area2, Area3, Area4]</b></p> <div style="display: flex; justify-content: space-around; text-align: center;"> <div> <p>Photometry Area</p>  <p>Off</p> </div> <div> <p>Photometry Area</p>  <p>Area1</p> </div> <div> <p>Photometry Area</p>  <p>Area2</p> </div> <div> <p>Photometry Area</p>  <p>Area3</p> </div> <div> <p>Photometry Area</p>  <p>Area4</p> </div> </div> <p><b>Memo:</b></p> <ul style="list-style-type: none"> <li>The backlight compensation area is not linked to digital PTZ.</li> </ul>
<b>④ B/W Mode</b>	
	This sets the function to switch from Color to B&W mode.
<b>Mode</b>	<p>Color : Always be in Color mode.          Black &amp; White : Always be in B&amp;W mode.          Auto : Auto Low, Auto Mid, Auto High          : This item automatically switches between Color Mode and B&amp;W Mode when the luminance meets defined conditions for over 30 seconds. Select the sensitivity from three options.</p> <p><b>[Setting value: Color, Black &amp; White, Auto]</b></p> <p><b>Memo:</b></p> <p><b>To ensure a successful B&amp;W/Color switching</b></p> <ul style="list-style-type: none"> <li>If the [B/W Mode] item is set to "Auto Low, Auto Mid, Auto High", the B&amp;W/Color setting can be switched according to the brightness of the object, but the condition of illumination and field angle may make this impossible. To be absolutely certain of B&amp;W/Color switching, connecting external sensor to alarm input cable of this camera and setting alarm action of B&amp;W mode is recommended.</li> </ul>

## Built-in Viewer (continued)

### PTZ Setting

#### ■ Preset Position

This page describes procedures for setting the preset positions.

- When a different menu is currently being displayed, click [Control] to switch the menu.
- Click the menu bar on the left side of the screen to open the setting screen.

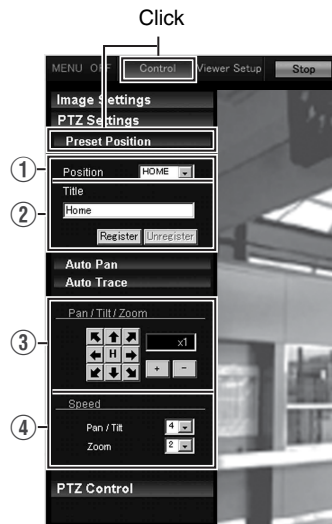

<p>■ <b>Preset Position</b></p>	<p>For setting the Preset Position.</p> <p><b>Note:</b> _____</p> <ul style="list-style-type: none"> <li>● When [Auto Flip] is set to “Digital Flip”, preset positions cannot be registered when the tilt angle is more than 90 degrees. [Auto Flip] (☞ Page 71)</li> <li>● When setting preset positions and [Pan Limit] is “On”, pan operation is unavailable in the prohibited areas. [Pan Limit] (☞ Page 69)</li> <li>● As moving preset positions has priority over pan limit, set the preset positions when [Pan Limit] is “Off”. After that, when [Pan Limit] is set to “On”, the camera will pan regardless of the prohibited areas. [Pan Limit] (☞ Page 69)</li> <li>● Items that are stored in the preset position include pan, tilt, zoom, focus, position title, white balance, iris, and backlight compensation.</li> </ul>
<p>① <b>Position</b></p>	<p>For selecting [Position].</p> <p><b>[Setting value:HOME, 1 to 99]</b></p>
<p>② <b>Title</b></p>	<p>The current title appears. Enter here to register or change the title. (Up to 32 alphanumeric characters can be entered. When JPEG viewer is used, up to 16 alphanumeric characters are displayed.)</p> <p><b>Memo:</b> _____</p> <ul style="list-style-type: none"> <li>● Click [Unreaiste] button to delete information of the selected position. However, [HOME] cannot be deleted.</li> <li>● The display area of Home position is set to the full screen by default.</li> </ul>
<p>③ <b>Pan /Tilt / Zoom</b></p>	<p>■ <b>Pan/Tilt operation</b></p> <p>Click the arrow buttons to move the display area in the direction indicated by the arrow. Release the button to stop the movement. Click the [H] button to move to the home position.</p> <p>■ <b>Zoom operation</b></p> <p>Use this function to perform zoom operation on the display area.</p> <p>[+] : Zoom is set to TELE and the object becomes bigger. [-] : Zoom is set to WIDE and the object becomes smaller.</p> <p>■ <b>Ratio to Full Area</b></p> <p>Shows current ratio to full area.</p> <p><b>Memo:</b> _____</p> <ul style="list-style-type: none"> <li>● You can restrict the magnification of the object using the [+] button by altering the [Zoom Limit] settings. (☞ Page 69)</li> </ul>
<p>④ <b>Speed</b></p>	<p>This item sets the operation speed.</p> <p>Pan/Tilt : This item sets the operation speed of the [Pan/Tilt] operation button.Increase the number to increase the operation speed. <b>[Setting range: 1 to 8]</b></p> <p>Zoom : This item sets the operation speed of the [Zoom] operation button.Increase the number to increase the operation speed. <b>[Setting range: 1 to 4]</b></p>

## Built-in Viewer (continued)

### PTZ Setting (continued)

#### ■ Auto Pan

For setting the Auto Pan.

- When a different menu is currently being displayed, click [Control] to switch the menu.
- Click the menu bar on the left side of the screen to open the setting screen.

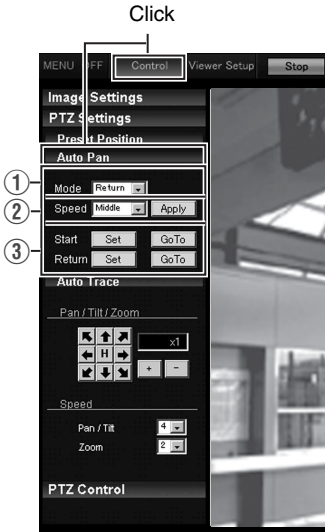



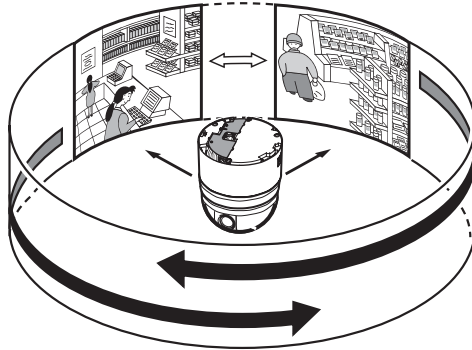

<p>■ <b>Auto Pan</b></p>	<p>This item sets the Auto Pan operation which moves at a specific speed from the preset [Start].</p>
<p>① <b>Mode</b></p>	<p>Select the [Mode] of the Auto Pan operation.</p> <p>Right : This rotates the camera horizontally in the right direction from the [Start Position].</p> <p>Left : This rotates the camera horizontally in the left direction from the [Start Position].</p> <p>Return : Moves between [Start Position] and [Return Position] in the clockwise direction from the [Start Position] toward the [Return Position]. You can specify any random position as the start and return positions except under the following conditions.</p> <p>Tilt angle of 90 ° or larger : An error message appears if the angle is set to 90 ° or larger.</p> <p>Electronic zoom area : When setting is performed using the electronic zoom area, optical zoom is automatically set to its largest magnification ratio.</p> <p><b>Memo:</b> _____</p> <ul style="list-style-type: none"> <li>● If the zoom ratio between the [Start Position] and [Return Position] is different from each other, linked operations between zoom and pan/tilt may not be even.</li> </ul>
<p>① <b>Speed</b></p>	<p>Select the Auto Pan operation speed. [Setting value:Low, Mid, High]</p>
<p>② <b>Start Position Return Position</b></p>	<p>Select the [Start Position] and [Return Position] (only during “Return”) of the operation. Operate the camera manually, decide on a position and click [Apply] to register. Click [Go To] to move the camera to the registered position.</p> <p><b>Memo:</b> _____</p> <ul style="list-style-type: none"> <li>● For details on the manual operation, see [PTZ Control] (☞ Page 113).</li> </ul>

## Built-in Viewer (continued)

### PTZ Setting (continued)

#### ■ Auto Trace

For setting the Auto Trace.

- When a different menu is currently being displayed, click [Control] to switch the menu.
- Click the menu bar on the left side of the screen to open the setting screen.



<p>■ <b>Auto Trace</b></p>	<p>This item stores and reproduces manual operation.</p> <p><b>Note:</b> _____</p> <ul style="list-style-type: none"> <li>● As Auto Trace performs simple saving of manual operation, the position may be shifted during playback.</li> <li>● Digital Flip cannot be used during Auto Trace recording. .</li> </ul>
<p>① <b>State</b></p>	<p>[Record Start] : The camera will start recording of Pan/Tilt and Zoom operations. (for approximately 30 seconds)</p> <p>[Record Stop] : Click this when a recording operation is complete.</p> <p><b>Memo:</b> _____</p> <ul style="list-style-type: none"> <li>● For details on the manual operation, see [PTZ Control] (☞ Page 113).</li> </ul> <p><b>[State] Display</b></p> <p>The current status is displayed.</p> <p>Standby : The camera is on standby. [Record Stop] is invalid.</p> <p>Recording : The camera is recording. Click [Record Stop] to finish recording. “Completed” will be displayed.</p> <p>Completed : Recording is completed. After “Completed” is displayed for 3 seconds, “Standby” will be displayed.</p> <p>Timeout : 30 seconds has passed since recording started. (Operation for the 30 seconds has been recorded.) After “Timeout” is displayed for 3 seconds, “Standby” will be displayed.</p> <p>Memory Full : The operation has exceeded the number of recordable operations. Further recording cannot be made even if it is within 30 seconds. (Operations before the limit are recorded.) After “Memory Full” is displayed for 3 seconds, “Standby” will be displayed.</p>
<p>② <b>Pan /Tilt /Zoom</b></p>	<p>■ <b>Pan/Tilt operation</b></p> <p>Click the arrow buttons to move the display area in the direction indicated by the arrow. Release the button to stop the movement. Click the [H] button to move to the home position.</p> <p>■ <b>Zoom operation</b></p> <p>Use this function to perform zoom operation on the display area.</p> <p>[+] : Zoom is set to TELE and the object becomes bigger.</p> <p>[-] : Zoom is set to WIDE and the object becomes smaller.</p> <p>■ <b>Ratio to Full Area</b></p> <p>Shows current ratio to full area.</p> <p><b>Memo:</b> _____</p> <ul style="list-style-type: none"> <li>● You can restrict the magnification of the object using the [+] button by altering the [Zoom Limit] settings. (☞ Page 69)</li> </ul>
<p>③ <b>Speed</b></p>	<p>This item sets the operation speed.</p> <p>Pan/Tilt : This item sets the operation speed of the [Pan/Tilt] operation button. Increase the number to increase the operation speed.</p> <p><b>[Setting range:1 to 8]</b></p> <p>Zoom : This item sets the operation speed of the [Zoom] operation button. Increase the number to increase the operation speed.</p> <p><b>[Setting range: 1 to 4]</b></p>

## Built-in Viewer (continued)

### PTZ Control

#### ■ PTZ Control

Use this item to operate the PTZ feature.

- When a different menu is currently being displayed, click [Control] to switch the menu.
- Click the menu bar on the left side of the screen to open the setting screen.



<b>■ PTZ Control</b>	For operating the camera and adjusting the angle and image quality of the position to be registered.
<b>① Auto Function</b>	<p>For selecting the operation.</p> <p>[Start] : Start the selected Auto function.</p> <p>[Stop] : Stop the running Auto function.</p> <p><b>Memo:</b> _____</p> <ul style="list-style-type: none"> <li>● When “Auto Patrol” is selected, the patrol mode list is displayed.</li> <li>● When “Intelligent Tracking” is selected, the target’s list is displayed.</li> </ul> <hr/> <p>Auto Pan : The configured Auto Pan operation is performed. (☞ Page 109)</p> <p>Auto Patrol : The configured Auto Patrol operation is executed. Select “Auto Patrol”. (☞ Page 72)</p> <p>Auto Trace : The configured Auto Trace operation is performed. (☞ Page 111)</p> <p>Auto Tracking : Auto tracking is performed. (☞ Page 67)</p> <p>Motion detection does not work during Auto Tracking.</p> <p>Intelligent Tracking : Intelligent tracking is performed. (☞ Page 116)</p> <p><b>Note:</b> _____</p> <ul style="list-style-type: none"> <li>● When the [Mode] item of [Auto Return] is set to “Auto Patrol” and Auto Patrol starts in this screen, the “Auto Patrol” mode of [Auto Return] will be changed to the mode that was started in this screen. [Auto Return] (☞ Page 66)</li> <li>● When “Auto Pan” starts, the camera will repeat the left rotate, right rotate or return operations.</li> <li>● When “Auto Patrol” starts, the camera will complete a series of operations and return to the start position, and then repeat the entire process. When Auto Trace starts, the camera will perform a series of operations before returning to the start position. It will resume after 30 seconds. If Auto Return function is set, the Auto function that was started manually is stopped when “Auto Return” starts.</li> </ul>
<b>② Preset Position</b>	For selecting the preset position. When the selected position has been registered, the camera will move to the selected position. <b>[Setting range: HOME, 1 to 19]</b>

## Built-in Viewer (continued)

### PTZ Control (continued)

<b>■ PTZ Control (continued)</b>	
<b>③ Focus</b>	<p>This item adjusts the focus.</p> <p>Mode : Shows the current mode.</p> <p>Easy AF : Auto Focus (AF) will activate automatically when the pan, tilt or zoom function is operated manually. This is convenient as you need not reset the focus everytime you move the camera when there are many manual operations.</p> <p>Manual : Click the [+], [-] buttons to adjust manually. The focus will change while the button is being pressed. It will stop when the button is released.</p> <p>[Focus] button : Click this button to focus automatically in about 1 second</p> <p><b>Memo:</b> _____</p> <ul style="list-style-type: none"> <li>● The “Easy AF” function may not focus properly for some objects. In this case, set the focus manually.</li> </ul>
<b>④ Pan /Tilt / Zoom</b>	<p><b>■ Pan/Tilt operation</b></p> <p>Click the arrow buttons to move the display area in the direction indicated by the arrow. Release the button to stop the movement. Click the [H] button to move to the home position.</p> <p><b>■ Zoom operation</b></p> <p>Use this function to perform zoom operation on the display area.</p> <p>[+] : Zoom is set to TELE and the object becomes bigger. [-] : Zoom is set to WIDE and the object becomes smaller.</p> <p><b>■ Ratio to Full Area</b></p> <p>Shows current ratio to full area.</p> <p><b>Memo:</b> _____</p> <ul style="list-style-type: none"> <li>● You can restrict the magnification of the object using the [+] button by altering the [Zoom Limit] settings. (☞ Page 69)</li> </ul>
<b>⑤ Speed</b>	<p>This item sets the operation speed.</p> <p>Pan/Tilt : This item sets the operation speed of the [Pan/Tilt] operation button. Increase the number to increase the operation speed. <b>[Setting range: 1 to 8]</b></p> <p>Zoom : This item sets the operation speed of the [Zoom] operation button. Increase the number to increase the operation speed. <b>[Setting range: 1 to 4]</b></p> <p>Variable Speed : This function adjusts the Pan/Tilt operation speed by the zoom ratio. Select the checkbox to slow down at the Tele end and to move quickly at the Wide end. Deselect the checkbox to move the camera at a constant speed configured in Pan/Tilt regardless of the zoom ratio.</p>

## ■ Intelligent Tracking feature

Use this item to operate the Intelligent Tracking feature.

- When a different menu is currently being displayed, click [Control] to switch the menu.
- Click each menu bar on the left of the screen to open the setting screen.

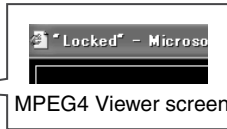
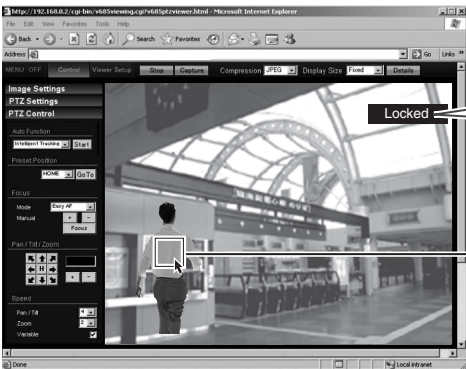
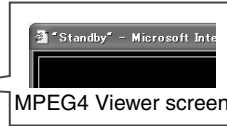

## Built-in Viewer (continued)

### PTZ Control (continued)

<b>■ Intelligent Tracking</b>	<p>Click on the object on the viewer screen to shoot the selected object by tracking its color information.</p> <p><b>Memo:</b></p> <ul style="list-style-type: none"><li>● You can change the object to track freely by clicking the object when “Locked” or “Losing” is displayed.</li><li>● You can select whether to display the [Tracking Frame] (JPEG Viewer only) and [Tracking Status] displays on the setting screen. (☞ Page 118)(☞ Page 121)</li></ul> <p><b>Note:</b></p> <ul style="list-style-type: none"><li>● When the OS of the computer is WindowsXP, click the viewer screen once to activate the screen before clicking on the object to track.</li></ul> <p>① <b>For selecting [Intelligent Tracking].</b></p> <p>② <b>Click [Start].</b></p> <ul style="list-style-type: none"><li>● Intelligent Tracking switches to the standby mode, and Standby is shown on the top right corner of the viewer screen. (JPEG Viewer)</li><li>● Intelligent Tracking switches to the standby mode, and Standby is shown in the title bar. (MPEG4 Viewer)</li></ul> <p>③ <b>Click on the object to track on the viewer screen.</b></p> <ul style="list-style-type: none"><li>● The object is surrounded by [Tracking Status] (blue frame). (JPEG Viewer only)</li><li>● When an object is being captured, “Locked” appears on the top right corner of the viewer screen. When the camera loses track of the object, this appears as “Losing”. (JPEG Viewer)</li><li>● When an object is being captured, “Locked” appears in the title bar. When the camera loses track of the object, this appears as “Losing”. (MPEG4 Viewer)</li></ul>
-------------------------------	--



## JPEG Viewer Settings

Using the compressed JPEG format enables display of a series of still images as well as one-shot recording of still images.

When the JPEG Viewer is first installed, it is set to play back at 15 fps by default.

- When a different menu is currently being displayed, click [Viewer Setup] to switch the menu.
- Click each menu bar on the left of the screen to open the setting screen.

### ■ On Screen Display

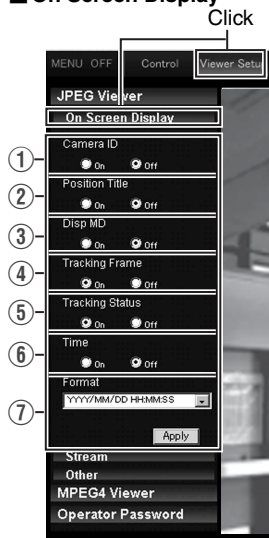

### ■ Stream

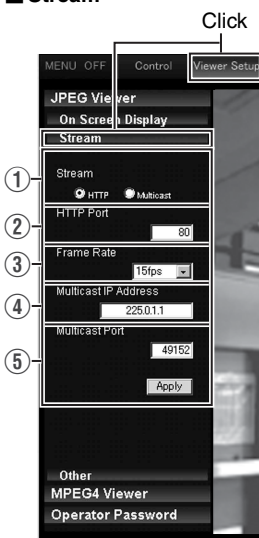

### ■ Other

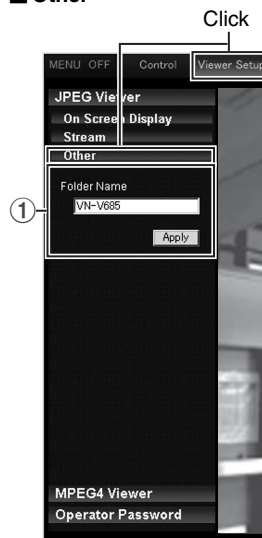

■ On Screen Display Settings	For setting display items on the viewer screen. For the JPEG Viewer, characters are displayed as overlay on the video image.
① <b>Camera ID</b>	Select "On" to display [Camera ID]. (Up to 16 alphanumeric characters will be displayed.) [Camera ID] can be specified on the [Basic Settings2] or [Camera] page. (☞ Page 51)
② <b>Position Title</b>	Select "On" to display the Position Title.
③ <b>Display MD</b>	Selecting "On" displays the area in which motion is detected in red.
④ <b>Tracking Frame</b>	When "On" is selected, the blue frame that surrounds the tracked object of "Intelligent Tracking" appears on the screen. (☞ Page 116)
⑤ <b>Tracking Status</b>	When "On" is selected, the "Intelligent Tracking" status appears as "Standby", "Locked", or "Losing" on the screen. (☞ Page 116)
⑥ <b>Time</b>	Select "On" to display the time. This indicates the time that is stored in the JPEG data.
⑦ <b>Format</b>	Select the format for displaying time. YYYY, MM, and DD denote year, month and day respectively, while HH, MM, and SS denote hour, minute and second respectively. mm is equivalent to 1/100 seconds.

## Built-in Viewer (continued)

### JPEG Viewer Settings (continued)

<p>■ <b>Stream</b></p>	<p>For specifying settings for receiving JPEG stream.</p>
<p>① <b>Stream</b></p>	<p>For selecting the protocol when the viewer acquires data from the camera. When “HTTP” is selected, lost packets are recovered via resending. Camera may be monitored using multiple viewers when “Multicast” is selected. When playing back via multicast, start multicast sending on the [Streaming] page. [Streaming Page] (☞ Page 82)</p> <p><b>Note:</b> _____</p> <ul style="list-style-type: none"> <li>● When Built-in Viewer is launched with “Multicast” specified, a Windows firewall warning may appear. In this case, select “unblock” and proceed.</li> <li>● If “block” is selected, the Windows firewall will block the multicast stream and playback of “Multicast” by the viewer will fail.</li> </ul>
<p>② <b>HTTP Port</b></p>	<p>You can change the HTTP port number. The default port number setting is “80”. Specify the same value as the parameter that is set on the [Protocol] page of the camera. (☞ Page 81)</p>
<p>③ <b>Frame Rate</b></p>	<p>For selecting the acquisition frame rate of the viewer. Selecting a large frame rate will increase the processing load of the computer on which the viewer is running. <b>[Setting values:30, 25, 15, 10, 7.5, 6, 5, 3, 2, 1, 1/2, 1/3, 1/5, 1/10, 1/15, 1/20, 1/30, 1/60]</b></p> <p><b>Note:</b> _____</p> <ul style="list-style-type: none"> <li>● Set to a rate such that the CPU burden of the computer does not exceed 80 %. If the CPU is overloaded, the computer may not function properly.</li> </ul>
<p>④ <b>Multicast IP Address</b></p>	<p>You can change the multicast IP address. The default IP address setting is “225.0.1.1”.</p>
<p>⑤ <b>Multicast Port</b></p>	<p>You can change the multicast port number. The default port number setting is “49152”.</p> <p><b>Memo:</b> _____</p> <ul style="list-style-type: none"> <li>● This is enabled when [Start] is selected for the[JPEG] [Control] item on the [Streaming] page.</li> <li>● Specify the same value as the parameter that is set on the [Streaming] page of the camera. (☞ Page 82)</li> </ul>
<p><b>Other</b></p>	
<p>① <b>Folder Name</b></p>	<p>For specifying the name of the folder in which the captured files are stored. (When the viewer is installed: “VN-V685”(VN-V685U), “VN-V686B”(VN-V686BU/VN-V686WPBU)</p>

---

## MPEG4 Viewer Settings

Using the compressed MPEG4 format enables display of MPEG4-encoded motion images.

- When a different menu is currently being displayed, click [Viewer Setup] to switch the menu.
- Click each menu bar on the left of the screen to open the setting screen.

### Memo:

- To use the MPEG4 Viewer of the camera, install the open source codec “ffdshow”. You can download “ffdshow” from the Internet.
- 

#### ■ Title Bar



#### ■ Stream

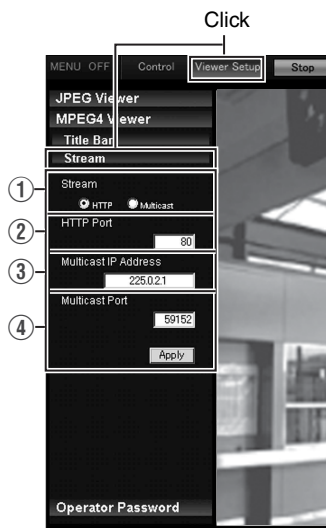

## Built-in Viewer (continued)

### MPEG4 Viewer Settings (continued)

<b>■ Title Bar</b>	For setting display items on the viewer screen. For the MPEG4 Viewer, characters are displayed in the title bar of the window.
① <b>Camera ID</b>	Select “On” to display [Camera ID]. (Up to 16 alphanumeric characters will be displayed.) [Camera ID] can be specified on the [Basic Settings2] or [Camera] page. (☞ Page 51)
② <b>Position Title</b>	Select “On” to display the title of the position that is being displayed.
③ <b>Tracking Frame</b>	When “On” is selected, the “Intelligent Tracking” status appears as “Standby”, “Recording”, or “Completed” on the screen. (☞ Page 69).
④ <b>Time</b>	Select “On” to display the time.
⑤ <b>Format</b>	Select the format for displaying time. YYYY, MM, and DD denote year, month and day respectively, while HH, MM, and SS denote hour, minute and second respectively. mm is equivalent to 1/100 seconds.
<b>■ Stream</b>	For specifying settings for receiving MPEG4 stream.
① <b>Stream</b>	For selecting the protocol when the viewer acquires data from the camera. When “HTTP” is selected, lost packets are recovered via resending. Camera may be monitored using multiple viewers when “Multicast” is selected. <b>Memo:</b> _____ <ul style="list-style-type: none"> <li>● When playing back via multicast, start multicast sending on the [Streaming] page of the camera unit.                      [Streaming Page] (☞ Page 82)</li> </ul> <b>Note:</b> _____ <ul style="list-style-type: none"> <li>● When Built-in Viewer is launched with “Multicast” specified, a Windows firewall warning may appear. In this case, select “unblock” and proceed.</li> <li>● If “block” is selected, the Windows firewall will block the multicast stream and playback of multicast by the viewer will fail.</li> </ul>
② <b>HTTP Port</b>	You can change the HTTP port number. The default port number setting is 80. Specify the same value as the parameter that is set on the [Protocol] page of the camera. (☞ Page 81)
③ <b>Multicast IP Address</b>	You can change the multicast IP address. The default address is 225.0.2.1.
④ <b>Multicast Port</b>	You can change the multicast port number. The default port number setting is 59152. <b>Memo:</b> _____ <ul style="list-style-type: none"> <li>● This is enabled when “Start” is selected for the [JPEG Control] item on the [Streaming] page.</li> <li>● Specify the same value as the parameter that is set on the [Streaming] page of the camera. (☞ Page 82)</li> </ul>

---

## Operator Password

This section describes the procedures for configuring the Operator Password, which is required for PTZ operation.

- When a different menu is currently being displayed, click [Viewer Setup] to switch the menu.
- Click the menu bar on the left side of the screen to open the setting screen.

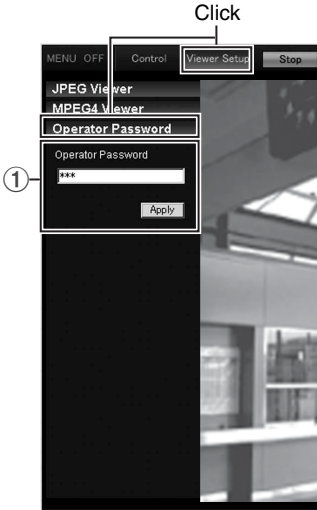

<b>■ Operator Password</b>	For configuring the Operator Password required for PTZ operation.
① <b>Operator Password</b>	Enter the Operator Password.

### Built-in Viewer (continued)

#### Exiting the Viewer

To exit, press the [X] button at the top right of the window.

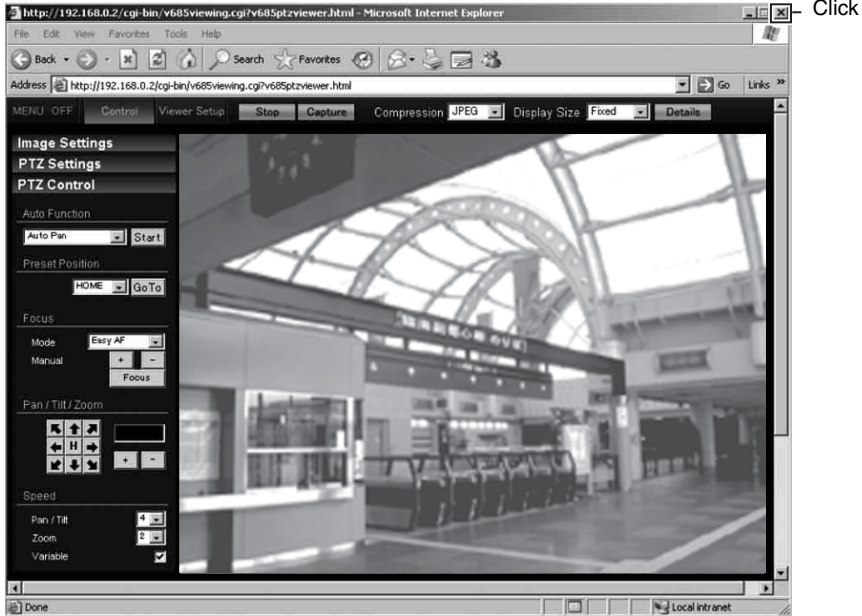

- During the next startup of Built-in Viewer, launch the Internet Explorer and enter the URL of the camera in the address field.

For example, if the IP address of the camera is 192.168.0.2, enter as follows:

`http://192.168.0.2/`

#### Memo:

- After the [Security Settings] screen appears, press the [OK] button to proceed.

## Troubleshooting

Symptom	Causes and Countermeasures	Reference Page
Video image does not appear Power does not turn on.	<ul style="list-style-type: none"> <li>● Is there a problem with the power cable connecting this unit and the power unit? (If the power cable is too long or thin, the cable resistance will be high and the correct voltage may not be supplied.)                             <ul style="list-style-type: none"> <li>➔Use a cable of low resistance and the correct cable length. (When the camera is operating (at rated current), check that the supplied voltage is of the rated voltage at the terminal of the camera.)</li> </ul> </li> </ul>	<ul style="list-style-type: none"> <li>☞ Page 23</li> <li>☞ Page 30</li> </ul>
	<ul style="list-style-type: none"> <li>● Is the lens cap attached?                             <ul style="list-style-type: none"> <li>➔Remove the lens cap.</li> </ul> </li> </ul>	<ul style="list-style-type: none"> <li>☞ Page 21</li> <li>☞ Page 26</li> </ul>
The power of the camera turns off when VN-V686WPBU is used in an environment under -10°C.	<ul style="list-style-type: none"> <li>● When power is supplied using PoE, the heater will not work. Use an AC 24 V power supply when using VN-V686WPBU in an environment under -10°C.</li> </ul>	☞ Page 30
The power does not turn on even when PoE is used to supply power.	<ul style="list-style-type: none"> <li>● With some PoE-compatible devices (such as a hub), power will not be supplied when connected to a certain number of PoE terminals which exceed the limit of total electrical power that can be supplied. Please refer to the instruction manual of PoE-compatible devices.</li> </ul>	
IP address of the camera is unknown	<ul style="list-style-type: none"> <li>● The default IP address is 192.168.0.2, and the default Subnet Mask is 255.255.255.0.</li> <li>● When [IP Setting] is set to “DHCP Enable”, this product will run using the default IP address when it is started up via a LAN in which a DHCP server does not exist.</li> <li>● Search tool in attached CD-ROM is available to look for the camera using a PC in the same LAN.</li> </ul>	☞ Page 40
The web page of the camera cannot be displayed	<p>Check the Internet Explorer settings. When a proxy server is in use, configure the proxy server settings of the Internet Explorer accordingly.</p>	☞ Page 44
Built-in Viewer cannot be installed	<p>Check the Internet Explorer settings. Built-in Viewer consists of a software component called ActiveX. The ActiveX is usually installed when Built-in Viewer is used for the first time. However, installation may be rejected depending on the Anti-virus software settings. In this case, change the settings of the Anti-virus software before installing Built-in Viewer.</p>	☞ Page 102

## Troubleshooting (continued)

Symptom	Causes and Countermeasures	Reference Page
Authentication by VeriSign appears during installation of Built-in Viewer	VeriSign's electronic signature is stored in Built-in Viewer. For computers with a network environment that is connected to the Internet, the authenticity of the Built-in Viewer can be verified via authentication by VeriSign.	—
Multicast images cannot be played back	<ul style="list-style-type: none"> <li>Start multicast transmission manually from the [Streaming] page of the camera.</li> <li>In the case of multicast reception at Built-in Viewer, check that the multicast address and port number of Built-in Viewer settings coincide with those on the [Streaming] page of the camera. Make use of a network that supports IGMP v2 for multicast transmission.</li> <li>Data may be blocked by the Windows firewall. When this occurs, perform the following to allow it to pass through. Windows XP: Double-click [Windows Firewall] under [Start]–[Control Panel], click the [Add Port...] button under the Exception tab, and register the port number to be allowed through the firewall in the Port Number field. Enter an arbitrary character string in the name field. Windows XP: Double-click [Allow a program through Windows Firewall.] under [Start]–[Control Panel]–[Windows Firewall], click the [Add Port...] button under the Exception tab, and register the port number to be allowed through the firewall in the Port Number field. Enter an arbitrary character string in the name field.</li> </ul>	<ul style="list-style-type: none"> <li>☞ Page 82</li> <li>☞ Page 119</li> <li>☞ Page 121</li> </ul>
The frame rate of the displayed image is low	<ul style="list-style-type: none"> <li>Check Built-in Viewer settings when a Built-in Viewer is in use.</li> <li>Frame rate will be constrained when the network bandwidth is narrow.</li> </ul>	<ul style="list-style-type: none"> <li>☞ Page 57</li> <li>☞ Page 82</li> <li>☞ Page 33</li> </ul>
A white zone appears in Built-in Viewer	For some computers, a part of the Internet Explorer graphics may not appear and is left white when the following setting is performed on the Internet Explorer. If [Right-click on the Desktop screen]–[Properties]–[Settings]–[Advanced]–[Advanced]–[DPI setting] is set to “Large size” or “Custom size”, select “Normal size(96DPI)” to resume normal drawing.	—
A warning message appears upon starting up Built-in Viewer	Built-in Viewer consists of a software component called ActiveX. The ActiveX is usually installed when Built-in Viewer is used for the first time. However, installation may be rejected depending on the Anti-virus software settings. In this case, change the settings of the Anti-virus software before installing Built-in Viewer.	—



Symptom	Causes and Countermeasures	Reference Page
TCP images cannot be played back	The maximum number of images that can be sent by the camera via TCP is 20, and up to 20 Built-in Viewers can be connected to each camera unit. Make use of multicast for monitoring when the number of areas exceeds the above number. Camera allows multicast transmission of JPEG and MPEG4 one stream at a time.	☞ Page 33
Unable to receive alarm notification using the computer via TCP/UDP	<ul style="list-style-type: none"> <li>● Data may be blocked by the Windows firewall. When this occurs, perform the following to allow it to pass through.  Windows XP:  Double-click [Windows Firewall] under [Start]–[Control Panel], click the [Add Port...] button under the Exception tab, and register the port number to be allowed through the firewall in the Port Number field. Enter an arbitrary character string in the name field.  Windows XP:  Double-click [Allow a program through Windows Firewall.] under [Start]–[Control Panel]–[Windows Firewall], click the [Add Port...] button under the Exception tab, and register the port number to be allowed through the firewall in the Port Number field. Enter an arbitrary character string in the name field.</li> </ul>	—
Power is turned on but it is disconnected once the camera rotates.	Are the transporting tape and cushioning material removed? ➔ Remove the transporting tape and cushioning material.	☞ Page 21 ☞ Page 26
Characters of the file name registered in the FTP server are garbled	When double-byte characters are to be used for the file name, make use of an FTP server for which the character code is EUC-JP.	☞ Page 63
The MPEG4 Viewer screen appears in black	Is ffdshow installed? To use the MPEG4 Viewer of the camera, install the open source codec “ffdshow”. You can download “ffdshow” from the Internet.	—
“Caution : The fan(T) is stopped” appears on the screen. (* denotes number)	The internal cooling fan is abnormal. Write down the displayed text of ➔ “Caution : The fan(T) is stopped” and consult your nearest JVC dealer. Turn off the power of this camera beforehand.	—
The camera pans automatically	When [Auto Cleaning] is set to “On”, this is not an abnormality. Check the settings.	☞ Page 89

# Specifications

## VN-V685U/VN-V686BU

### ■ CAMERA HEAD

- Image pickup device: 1/4 type, Interline Transfer CCD  
768 (H) x 494 (V)
- Minimum brightness of object
- Color : 1.0 lx (50 % output, AGC Super, WIDE edge, Monitor Type CRT, Black Level 2)  
0.5 lx (25 % output, AGC Super, WIDE edge, Monitor Type CRT, Black Level 2)
- During B&W : 0.08 lx (50 % output, AGC Super, WIDE edge, Monitor Type CRT, Black Level 2)  
0.04 lx (25 % output, AGC Super, WIDE edge, Monitor Type CRT, Black Level 2)
- White balance : Select from ATW-Narrow/ATW-Wide/AWC
- Electronic Shutter : 1/60, 1/100, (50 Hz Flickerless), 1/250, 1/500, 1/1000, 1/2000, 1/4000, 1/10000
- Backlight Compensation : 4 photometry areas can be selected
- Color level adjustment : YES
- Contour adjustment : Effective for both horizontal and vertical (adjustable level)

### ■ Network section

- Image compression format : JPEG, MPEG4
- Frame size : 640 × 480, 320 × 240
- Network interface : 100BASE-TX/10BASE-T/FULL/HALF/Auto negotiation supported
- Internal memory : 8 MB

### ■ LAN Specifications

- Compliant with IEEE802.3 and IEEE802.3u
- Communication protocol : TCP/IP, UDP, HTTP, FTP, ICMP, ARP, DHCP, SNTP, SMTP, DSCP, IGMP

### ■ Lens (VN-V685U)

- Zoom ratio : Approx. 27 times
- Focal length : 3.43 mm to 92.6 mm
- Maximum aperture ratio : F1.6 (WIDE) to F3.5 (TELE)
- Aperture range : F1.6 (Opened fully) to Equivalent to F360
- Maximum close-range : Approx. 1.8 m (TELE)  
Approx. 0.6 m (WIDE)

### ■ Lens (VN-V686BU)

- Zoom ratio : Approx. 36 times
- Focal length : 3.43 mm to 122 mm
- Maximum aperture ratio: F1.6 (WIDE) to F4.5 (TELE)
- Aperture range : F1.6 (Opened fully) to Equivalent to F360
- Maximum close-range : Approx. 1.8 m (TELE)  
Approx. 0.6 m (WIDE)

### ■ Rotation platform

- Horizontal rotation range : 360°Endless rotation
- Horizontal rotation speed : Approx. 0.04°/s to Approx. 400°/s
- Vertical rotation range : -5° to 185°  
(Horizontal to Face bottom to Horizontal)
- Vertical rotation speed : Approx. 0.04°/s to Approx. 400°/s

### ■ Overall

- Alarm input : No-voltage a contact input, NPN open collector input, low level, latch/momentary (200 ms and above) (Circuit current during low level: 1 mA; Applied voltage during high level: DC 3.3 V)
- Alarm output : NPN open collector output (Allowable applied voltage:DC20 V; Allowable inflow current: 25 mA)
- Supply voltage : AC 24 V 50 Hz/60 Hz or PoE(DC - 48 V)
- Current consumption : AC 24 V 1.2 A
- Power consumption : PoE 12.95 W
- Number of preset positions : Up to 100
- Surrounding temperature : -10 °C to 50 °C (operation)  
0 °C to 40 °C(Recommended)
- Ambient humidity : 20 % RH to 90 % RH (without condensation)
- Mass : Approx. 1.9 kg



## Specifications (continued)

### VN-V686WPBU

#### ■ CAMERA HEAD

Image pickup device: 1/4 type, Interline Transfer CCD  
768 (H) x 494 (V)

Minimum brightness of object

Color : 1.0 lx (50 % output, AGC Super, WIDE edge, Monitor Type CRT, Black Level 2)  
0.5 lx (25 % output, AGC Super, WIDE edge, Monitor Type CRT, Black Level 2)

During B&W : 0.08 lx (50 % output, AGC Super, WIDE edge, Monitor Type CRT, Black Level 2)  
0.04 lx (25 % output, AGC Super, WIDE edge, Monitor Type CRT, Black Level 2)

White balance : Select from ATW-Narrow/ATW-Wide/AWC

Electronic Shutter : 1/60, 1/100, (50 Hz Flickerless),  
1/250, 1/500, 1/1000,  
1/2000, 1/4000, 1/10000

Backlight Compensation : 4 photometry areas can be selected

Color level adjustment : YES

Contour adjustment : Effective for both horizontal and vertical (adjustable level)

#### ■ Network section

Image compression format : JPEG, MPEG4  
Frame size : 640 × 480  
320 × 240  
Network interface : 100BASE-TX/10BASE-T/FULL/  
HALF/Auto negotiation supported  
Internal memory : 8 MB

#### ■ LAN Specifications

Compliant with IEEE802.3 and IEEE802.3u  
Communication protocol : TCP/IP, UDP, HTTP, FTP, ICMP,  
ARP, DHCP, SNMP, SMTP, DSCP,  
IGMP

#### ■ Lens

Zoom ratio : Approx. 36 times  
Focal length : 3.43 mm to 122 mm  
Maximum aperture ratio : F1.6 (WIDE) to F4.5 (TELE)  
Aperture range : F1.6 (Opened fully) to Equivalent  
to F360

Maximum close-range : Approx. 1.8 m (TELE)  
Approx. 0.6 m (WIDE)

#### ■ Rotation platform

Horizontal rotation range : 360 °Endless rotation  
Horizontal rotation speed : Approx. 0.04°/s to Approx. 400°/s  
Vertical rotation range : -5° to 185°  
(Horizontal to Face bottom to Horizontal)  
Vertical rotation speed : Approx. 0.04°/s to Approx. 400°/s

#### ■ Overall

Alarm input : No-voltage a contact input, NPN open collector input, low level, latch/momentary (200 ms and above) (Circuit current during low level: 1 mA; Applied voltage during high level: DC 3.3 V)  
Alarm output : NPN open collector output (Allowable applied voltage:DC20 V; Allowable inflow current: 25 mA)  
Number of preset positions : Up to 100  
Supply voltage : AC 24 V 50 Hz/60 Hz or PoE(DC - 48 V)  
Current consumption AC 24 V power supply : AC 24 V 2.2 A,  
Power consumption PoE power supply : PoE 12.95 W  
Surrounding temperature ● When heater is in use : -40 °C to 50 °C (operation)  
-30°C to 40°C (recommended)  
※ Connect to AC 24 V when using the heater.  
※ If the temperature is between -40°C to -20°C when power is turned on, images may not be displayed until the heater takes effect (about 2 hours).  
● When heater is not in use : -10 °C to 50 °C (operation)  
0°C to 40°C (recommended)  
Ambient humidity : 20 % RH to 90 % RH (without condensation)  
Dust-proof, Waterproof : IP66 (IEC60529)  
Mass : Approx. 5.5 kg

## ■ Accessories

- : Read Me First ..... 1
- CD-ROM ..... 1
- Warranty Card (For USA)..... 1
- Service Information Card (For USA)... 1
- RJ-45 Conversion Connector..... 1
- SILICA GEL ..... 3

## ■ Dimension [Unit: mm (inch)]

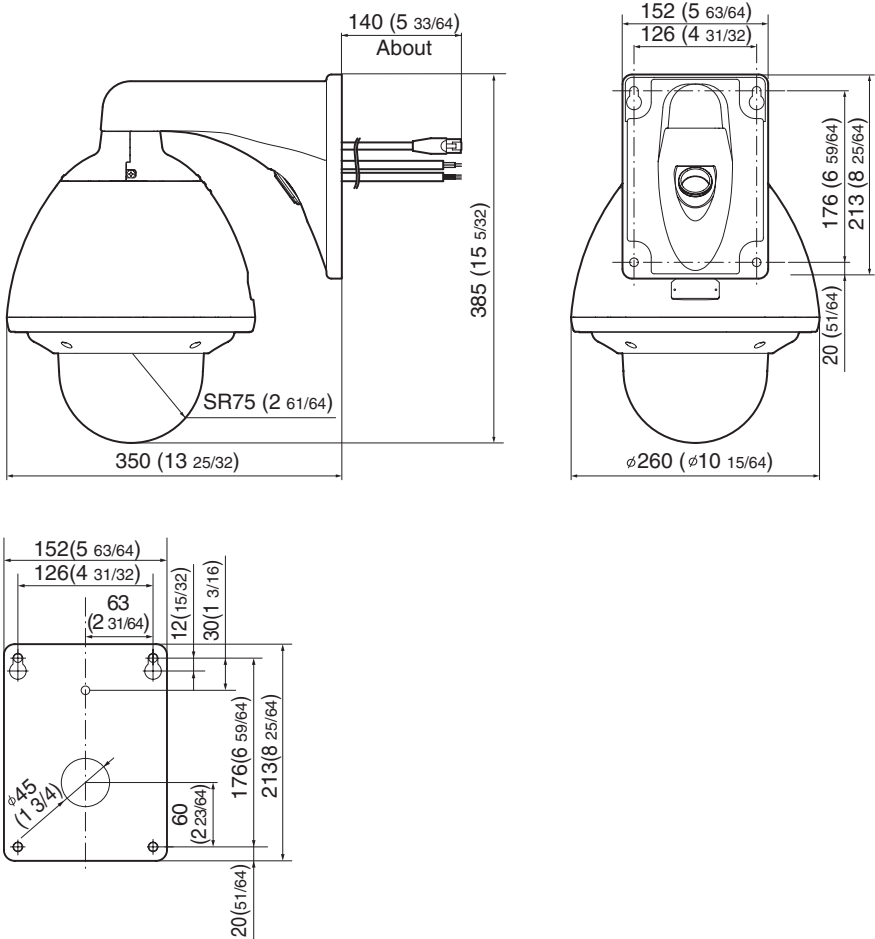

\* Specifications and appearance of this unit are subject to change for further improvement without prior notice.

VN-V685U/VN-V686BU  
PTZ IP DOME CAMERA  
VN-V686WPBU  
OUTDOOR PTZ IP DOME CAMERA

---

**JVC**