



SPEED RACER

Keep these instructions for future reference; they contain important information.

IMPORTANT: Please read all "Consumer Information" before operating your vehicle.

ADULT SUPERVISION REQUIRED.

Surfaces may become hot and cause burns if electronics get wet. Do not operate vehicle through water or snow.

Consumer Information:

Note to Adults: to ensure that the child's play is both safe and fun, please review all operating instructions and safety rules with your child.

CONTENTS

- 1 X Vehicle
- 1 X Transmitter Controller (with charger box)

Safety Tips

- NEVER drive your vehicle on streets!
- They're for real cars!
- DO NOT pick up vehicle while in motion.
- Avoid collisions with wall or hard surfaces.
- Keep fingers, hair and loose clothing away from tires and the wheel hubs.
- Adult supervision is recommended when this vehicle is being operated.
- To avoid accidental operation, remove all removable batteries when not in use.
- Be sure to rest your vehicle for at least 5 minutes after every 15 minutes of operation.

BEFORE BATTERY INSTALLATION

Your new RC is designed to work with a built-in Ni-MH rechargeable battery. Controller (with charger box) is designed to work with standard 2 (two) "AA" alkaline batteries, sold separately.

INSTALLING BATTERIES IN THE CHARGER BOX

1. Press the release button on controller to release the charger box. (See diagram 1)
2. Use a Phillips screwdriver (not included), to open the battery compartment door.
3. Insert the 2 "AA" alkaline batteries, with polarity (+/-) as shown inside battery compartment.
4. Replace the battery compartment door and use Phillips screwdriver to lock the compartment door.

CHARGING THE VEHICLE:

1. Insert charger jack into socket under the vehicle. (See diagram 2)
2. The charger box LED indicator will light up while charging.
3. Wait until the LED indicator turns off, the vehicle is charged.
4. Disconnect the vehicle from the charger box. Put the charger box back into the controller. (See diagram 3)

CAUTION:

Use only the charger box included with this toy. Do not use any other power source to charge the vehicle. Do not attempt to recharge a charged vehicle. Over charging may shorten the rechargeable battery's life. Regularly examine the charger box, vehicle and connectors. In the event of damage, do not use.

Battery Performance Note:

- A full charge will give your vehicle a certain minutes of driving, depends on your driving style.
- When your vehicle start to lose power it is time to recharge.
- When the charger box no longer recharge the vehicle, it's time to replace fresh batteries in charger box.

Battery Safety Information

- Insure that battery polarity is correct.
- Use only batteries of the type recommended (or equivalent).
- Do not mix old and new batteries.
- Do not mix alkaline, standard (carbon-zinc), or rechargeable (nickel-cadmium) batteries.
- Remove used-up batteries immediately. Remove all removable batteries if vehicle will not be used for a long period of time to prevent possible leakage.
- Do not recharge non-rechargeable batteries.
- Do not short-circuit terminals.
- Dispose of batteries safely. Do not dispose of batteries (or products containing non-replaceable batteries) in fire, as batteries may explode or leak.
- Do not recharge the vehicle if it is hot. Allow it to cool before recharge.
- Do not disassemble the vehicle's permanently installed rechargeable battery. The battery is a sealed Ni-MH (Nickel - Metal Hydride) battery. It is non-replaceable. Do not use more than 1 charger box at a time.
- If rechargeable batteries are used in charger box, rechargeable batteries are to be removed from the toy before being charged.

QUICK TIPS

- When your vehicle starts to lose power, it may lose functions or performance. It's time for fresh batteries (or a recharge). Your vehicle's running time may change depending on your driving style.
- Radio interference can make your vehicle run badly. Interference can be caused by other RC vehicles running on the same frequency, electrical wires, large buildings, or CB radios. Try to stay away from these!
- Point your transmitter controller antenna up - not down toward your vehicle. If your vehicle gets too far away, it won't work properly.
- Don't drive your vehicle in sand or through water or snow.
- Don't store your vehicle near heat or in direct sunlight.
- Always turn switches OFF and remove all batteries for storage.

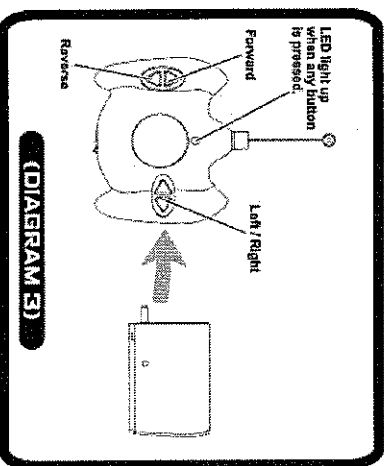
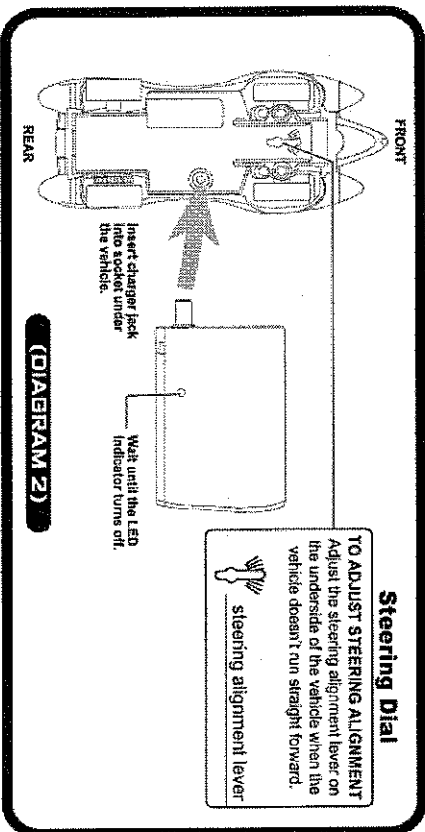
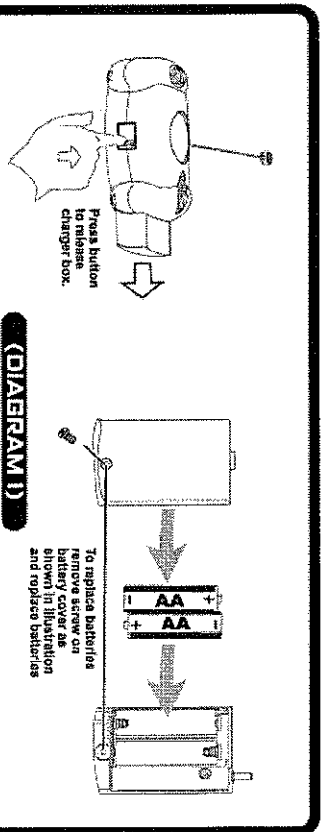

Cleaning Instructions:

To clean, wipe excess dirt from toy. Remove batteries and disconnect the vehicle from charger box first. Wipe toy clean with wet cloth using plain water. Wipe dry. DO NOT IMMERSIVE IN WATER and DO NOT CLEAN VEHICLE WITH ANY CHEMICALS. Let the toy completely dry up before putting batteries back into clean, dry battery compartment.



©2007 Speed Racer Enterprises, Inc. All Rights Reserved. Speed Racer is a trademark of Speed Racer Enterprises, Inc. and is used under license. Jada oval mark is a trademark of Jada Toys, Inc. ©2007 Jada Toys, Inc., City Of Industry, CA 91748

TROUBLE SHOOTING

PROBLEM	SOLUTION
Car does not START	1. Batteries are installed with incorrect polarities. Check the + and - markings to make sure the batteries are properly aligned. 2. Batteries are drained. Charge batteries and/or install new batteries.
Car does not respond to controls.	1. Transmitter controller battery is drained or charger box not in proper position. Replace the controller batteries or re-install the charger box. 2. Vehicle is out of range. Bring controller closer to the vehicle. 3. Interference from surrounding electrical machinery. Bring to a wide open space.
Car does not drive straight.	1. Adjust the steering dial underneath the front axle, left or right, until the wheels point straight forward. 2. Clean the tires with wet cloth using plain water. Wipe dry.

WWW.JADATOYS.COM

COMPLIANCE WITH FCC REGULATIONS (VALID IN U.S. ONLY) THIS DEVICE COMPLIES WITH PART 15 FCC RULES. OPERATION OF THIS DEVICE IS SUBJECT TO THE FOLLOWING TWO CONDITIONS:

1. THIS DEVICE MAY NOT CAUSE HARMFUL INTERFERENCE.
2. THIS DEVICE MUST ACCEPT ANY HARMFUL UNDESIRABLE OPERATION.

This device generates and uses radio frequency energy and if not used properly may cause interference to radio and television reception. It has been tested and found to comply with the limits set by the FCC which are designed to provide reasonable protection against such interference.

FCC Warning: CAUTION:

The manufacturer is not responsible for any radio or TV interference caused by unauthorized modifications to this equipment. Changes or modifications not expressly approved by the party responsible for compliance could void the user's authority to operate the equipment.

NOTE: This equipment has been tested and found to comply with the limits for a Class B digital device, pursuant to Part 15 of the FCC Rules. These limits are designed to provide reasonable protection against harmful interference in a residential installation. This equipment generates, uses and can radiate radio frequency energy and, if not installed and used in accordance with the instructions, may cause harmful interference to radio communications. However, there is no guarantee that interference will not occur in a particular installation. If this equipment does cause harmful interference to radio or television reception, which can be determined by turning the equipment off and on, the user is encouraged to try to correct the interference by one or more of the following measures:

- Reorient or relocate the receiving antenna.
- Increase the separation between the equipment and receiver.
- Connect the equipment into an outlet on a circuit different from that to which the receiver is connected.
- Consult the dealer or an experienced radio/TV technician for help.

Important! Problems?



Before taking your new RC back to the retailer, call our friendly RC technicians at:

1-800-679-5232

between the hours of 9 am to 5 pm Pacific Time; Monday - Friday.

WWW.JADATOYS.COM

Questions or problems with your vehicle?

DO NOT RETURN IT TO THE STORE!

U.S.A. & Canada
60-Day Limited Warranty
Jada Toys RC Products

Jada Toys, Inc. warrants to the original consumer purchaser that this product will be free of defects in material and workmanship for sixty (60) days from the date of purchase. Jada Toys will repair or replace the product, at our sole option, in the event of such a defect within the warranty period.

In the event of a defect covered under this warranty, first call the toll-free number listed below. Many problems can be solved in this manner. If necessary, you will be instructed to return the product, postage pre-paid and insured, to the address below.

Enclose your name, address, telephone number, copy of dated sales receipt, and a brief explanation of the defect. Repair or replacement, and return shipment, will be free of charge. Please return on the defective part or unit, packed securely. This warranty does not cover damage resulting from unauthorized modification, accident, misuse or abuse. If the product is returned without a dated sales receipt, the product may be excluded from coverage under this warranty.

Jada Toy's liability for defects in material and workmanship under this warranty shall be limited to repair or replacement, at our sole option, and in no event shall we be responsible for incidental, consequential, or contingent damages (except in those states that do not allow this exclusion or limitation). This warranty is exclusive, and is made in lieu of any express or implied warranty. Valid only in U.S.A. and Canada. This warranty gives you specific legal rights and you may have other rights, which may vary from state to state. Some states do not allow the exclusion of incidental or consequential damages, so the above exclusions or limitations may not apply to you.

TOLL-FREE NUMBER: 1-800-679-JADA (5232) (valid only in U.S.A. and Canada)
Hours: 9:00 A.M. - 5:00 P.M. Pacific Time; Monday - Friday. Expect some delay in January following the holiday season.

Please be patient and keep trying the toll-free number.

Address for Returns:
Consumer Relations, Jada Toys, Inc.
938 Hatcher Ave.
City of Industry, CA 91748