



BY APPOINTMENT TO
HER MAJESTY QUEEN ELIZABETH II
MANUFACTURERS OF DAIMLER AND JAGUAR CARS
JAGUAR CARS LIMITED COVENTRY



BY APPOINTMENT TO
HER MAJESTY QUEEN ELIZABETH
THE QUEEN MOTHER
MANUFACTURERS OF DAIMLER AND JAGUAR CARS
JAGUAR CARS LIMITED COVENTRY



BY APPOINTMENT TO
HIS ROYAL HIGHNESS THE PRINCE OF WALES
MANUFACTURERS OF DAIMLER AND JAGUAR CARS
JAGUAR CARS LIMITED COVENTRY

JAGUAR S-TYPE

2002 Model Year Electrical Guide

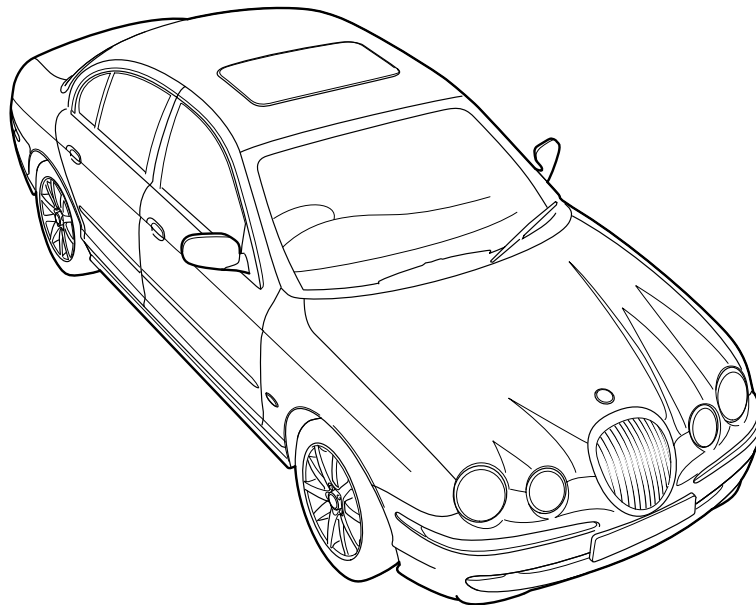

Published by Parts and Service Communications
Jaguar Cars Limited

Publication Part Number – JJM 10 38 16/25





Table of Contents: Figures 2 – 3

Abbreviations and Acronyms 4

Introduction 5

Symbols and Codes 6 – 8

Network Configuration 9

Fuse Box Location 10

Relay and Fuse Location 11

Harness In-Line Connectors 12 – 13

Control Module Location 14 – 15

Ground Point Location 16

Electrical Guide Figures follows after page 16
(pages are numbered by Figure number)



FIGURES

Fig.	Description	Variant
01 Power Distribution		
Fig. 01.1	Main Power Distribution	All Vehicles
Fig. 01.2	Battery Power Distribution: Part 1	All Vehicles
Fig. 01.3	Battery Power Distribution: Part 2	All Vehicles
Fig. 01.4	Ignition Switched Power Distribution: I (Accessory)	All Vehicles
Fig. 01.5	Ignition Switched Power Distribution: II (Run)	All Vehicles
Fig. 01.6	Switched System Power Distribution	All Vehicles
Fig. 01.7	Engine Management System Switched Power Distribution	All Vehicles
02 Battery; Starter; Generator		
Fig. 02.1	Battery; Starter; Generator: V6	V6 Vehicles
Fig. 02.2	Battery; Starter; Generator: V8	V8 Vehicles
03 Engine Management		
Fig. 03.1	Engine Management: V6 – Part 1	V6 Vehicles
Fig. 03.2	Engine Management: V6 – Part 2	V6 Vehicles
Fig. 03.3	Engine Management: V8 N/A – Part 1	V8 N/A Vehicles
Fig. 03.4	Engine Management: V8 N/A – Part 2	V8 N/A Vehicles
Fig. 03.5	Engine Management: V8 SC – Part 1	V8 SC Vehicles
Fig. 03.6	Engine Management: V8 SC – Part 2	V8 SC Vehicles
04 Transmission		
Fig. 04.1	Transmissions	All Vehicles
05 Chassis		
Fig. 05.1	Dynamic Stability Control	All Vehicles
Fig. 05.2	Electronic Parking Brake; Variable Assist Power Steering	All Vehicles
Fig. 05.3	Adaptive Speed Control	Adaptive Speed Control Vehicles
Fig. 05.4	Suspension Adaptive Damping	Adaptive Damping Vehicles
06 Climate Control		
Fig. 06.1	Climate Control System; Windshield Heaters	All Vehicles
07 Instrumentation		
Fig. 07.1	Instrument Cluster; Audible Warnings	All Vehicles
08 Exterior Lighting		
Fig. 08.1	Exterior Lighting: Front	Non HID Headlamp Vehicles
Fig. 08.2	Exterior Lighting: Front – HID	HID Headlamp Vehicles
Fig. 08.3	Exterior Lighting: Rear	All Vehicles
Fig. 08.4	Exterior Lighting: Rear – Trailer Towing	Trailer Towing Vehicles
Fig. 08.5	Headlamp Leveling	Headlamp Leveling Vehicles
09 Interior Lighting		
Fig. 09.1	Interior Lighting	All Vehicles
Fig. 09.2	Dimmer-Controlled Lighting	All Vehicles
10 Steering Column; Pedals; Mirrors; Heaters		
Fig. 10.1	Steering Column Adjust; Pedal Adjust	All Vehicles
Fig. 10.2	Door Mirrors: Movement and Heaters; Heated Rear Window	All Vehicles
Fig. 10.3	Electrochromic Rear View Mirror; Fold-Back Mirrors	All Vehicles; Fold-Back Mirror Vehicles

**FIGURES**

Fig.	Description	Variant
11	Seat Systems	
Fig. 11.1 Driver Seat: 10-Way Movement with Memory	10-Way Driver Seat Memory Vehicles
Fig. 11.2 Driver Seat: 16-Way Movement with Memory	16-Way Driver Seat Memory Vehicles
Fig. 11.3 Driver Seat: Non Memory	Non Memory Driver Seat Vehicles
Fig. 11.4 Passenger Seat	6 / 8 / 10-Way Passenger Seat Vehicles
Fig. 11.5 Passenger Seat: 16-Way Movement	16-Way Passenger Seat Vehicles
Fig. 11.6 Seat Heaters	Heated Seat Vehicles
12	Central Locking; Security	
Fig. 12.1 Central Locking: Double Locking	Double Locking Vehicles
Fig. 12.2 Central Locking: Non Double Locking	Non Double Locking Vehicles
Fig. 12.3 Security System	All Vehicles
13	Wash / Wipe	
Fig. 13.1 Wash / Wipe System	All Vehicles
14	Powered Windows; Sliding Roof	
Fig. 14.1 Powered Windows; Sliding Roof	All Vehicles
15	In-Car Entertainment	
Fig. 15.1 In-Car Entertainment: Standard	Standard ICE Vehicles
Fig. 15.2 In-Car Entertainment: Premium	Premium ICE Vehicles
16	Telematics	
Fig. 16.1 Telephone System: ROW	ROW Vehicles
Fig. 16.2 Telephone System: NAS	NAS Vehicles
Fig. 16.3 Telephone System with Voice: ROW	ROW Vehicles
Fig. 16.4 Telephone System with Voice: NAS	NAS Vehicles
Fig. 16.5 Voice Control System	Voice Only Vehicles
Fig. 16.6 Navigation System (except Japan)	Navigation Vehicles (except Japan)
Fig. 16.7 Navigation System with TV (except Japan)	Navigation Vehicles with TV (except Japan)
Fig. 16.8 Navigation System: Japan	Japan Navigation Vehicles
17	Occupant Protection	
Fig. 17.1 Advanced Restraint System: Part 1	All Vehicles
Fig. 17.2 Advanced Restraint System: Part 2	All Vehicles
18	Driver Assist	
Fig. 18.1 Parking Aid System	Parking Aid Vehicles
19	Ancillaries	
Fig. 19.1 Ancillaries: Horn, Cigar Lighter, Power Point, Accessory Connector, Sun Shade, Singapore Road Pricing	All Vehicles
20	Vehicle Multiplex Systems	
Fig. 20.1 Controller Area Network	All Vehicles
Fig. 20.2 Standard Corporate Protocol Network; Serial Data Link	All Vehicles
Fig. 20.3 D2B Network: Part 1	All Vehicles
Fig. 20.4 D2B Network: Part 2	All Vehicles
Fig. 20.5 D2B Network: Part 3	All Vehicles



The following abbreviations and acronyms are used throughout this Electrical Guide:

A/C	Air Conditioning
A/CCM	Air Conditioning Control Module
APP SENSOR	Accelerator Pedal Position Sensor
APP1	Accelerator Pedal Position Sensor Element 1
APP2	Accelerator Pedal Position Sensor Element 2
AUTO	Automatic Transmission
B+	Battery Voltage
BANK 1	RH Cylinder Bank (Cylinders 1, 3, 5, 7)
BANK 2	LH Cylinder Bank (Cylinders 2, 4, 6, 8)
CAN	Controller Area Network
CKP SENSOR	Crankshaft Position Sensor
CM	Control Module
CMP SENSOR / 1	Camshaft Position Sensor / RH Bank
CMP SENSOR / 2	Camshaft Position Sensor / LH Bank
D2B	D2B Network
DSC	Dynamic Stability Control
ECM	Engine Control Module
ECT SENSOR	Engine Coolant Temperature Sensor
EFT SENSOR	Engine Fuel Temperature Sensor
EGT SENSOR	Exhaust Gas Temperature Sensor
EOT SENSOR	Engine Oil Temperature Sensor
EVAP CANISTER CLOSE VALVE	Evaporative Emission Canister Close Valve
EVAP CANISTER PURGE VALVE	Evaporative Emission Canister Purge Valve
FTP SENSOR	Fuel Tank Pressure Sensor
GECM	General Electronic Control Module
GPS	Global Positioning System
HID	High Intensity Discharge
HO2 SENSOR 1 / 1	Heated Oxygen Sensor – RH Bank / Upstream
HO2 SENSOR 1 / 2	Heated Oxygen Sensor – RH Bank / Downstream
HO2 SENSOR 2 / 1	Heated Oxygen Sensor – LH Bank / Upstream
HO2 SENSOR 2 / 2	Heated Oxygen Sensor – LH Bank / Downstream
IAT SENSOR	Intake Air Temperature Sensor
IC	Instrument Cluster
ICE	In-Car Entertainment System
IMT VALVE / 1	Intake Manifold Tuning Valve / Top
IMT VALVE / 2	Intake Manifold Tuning Valve / Bottom
IP SENSOR	Injection Pressure Sensor
KS / 1	Knock Sensor / RH Bank
KS / 2	Knock Sensor / LH Bank
LH	Left Hand
LHD	Left Hand Drive
MAF SENSOR	Mass Air Flow Sensor
MAN	Manual Transmission
MAP SENSOR	Manifold Absolute Pressure Sensor
N/A	Normally Aspirated
NAS	North American Specification
PATS	Passive Anti-Theft System
PWM	Pulse Width Modulated
RH	Right Hand
RHD	Right Hand Drive
ROW	Rest of World
SCP	Standard Corporate Protocol Network
TCM	Transmission Control Module
TP SENSOR	Throttle Position Sensor
TP1	Throttle Position Sensor Element 1
TP2	Throttle Position Sensor Element 2
TURN	Turn Signal
TV	Television
V6	V6 Engine
V8	V8 Engine
VICS	Vehicle Information Control System
VVT VALVE / 1	Variable Valve Timing Valve / Bank 1
VVT VALVE / 2	Variable Valve Timing Valve / Bank 2
+ve	Positive
-ve	Negative



Provisional Electrical Guide Format

This Provisional Electrical Guide is an abridged version made up of two sections. The first section provides general information for and about the use of the book and information and illustrations to aid in the location of components.

The Figure section illustrates detailed electrical circuit information for each system on the vehicle. Each Figure is identified by a Figure Number (i.e. Fig. 01.1) and Title. The data that normally accompanies each Figure is not included in this Provisional version.

It is recommended that the user read through the front section of the book to develop a familiarity with the layout of the book and with the system of symbols and abbreviations used. The Table of Contents should help to guide the user.

Jaguar S-TYPE Electrical System Architecture

Power Supplies

The Jaguar S-TYPE electrical system is a supply-side switched system. The ignition switch directly carries much of the ignition switched power supply load. Power supply is provided via three methods: direct battery power supply, ignition switched power supply, and "Switched System Power Supply". The "Switched System Power Supply" circuit is controlled via the GECM (General Electronic Control Module) and the RECM (Rear Electronic Control Module). Refer to Figure 01.6 for circuit activation details.

Fuse Boxes

The electrical harness incorporates two hard-wired power distribution fuse boxes: the Front Power Distribution Fuse Box located in the engine compartment and the Rear Power Distribution Fuse Box located in the trunk. A serviceable Primary Junction Fuse Box is located in the front right-hand foot well. All fuses and relays (except the trailer towing accessory kit) are located in the two fuse boxes.

Vehicle Networks

The New Jaguar S-TYPE employs three different networks: a CAN (Controller Area Network) for high-speed power train communications, an SCP (Standard Corporate Protocol) network for slower speed body systems communications, and a D2B (Optical) Network for very high-speed "real-time" audio data transfer. The D2B Network is a fiber optic network with a gateway to the remaining vehicle networks via the Audio Unit. Technician access to the three networks and the Serial Data Link is via the Data Link Connector.

Ground Studs

Circuit ground connections are made at body studs located throughout the vehicle. There are no separate power and logic grounding systems; however, there are a certain number of components that use unique ground points.



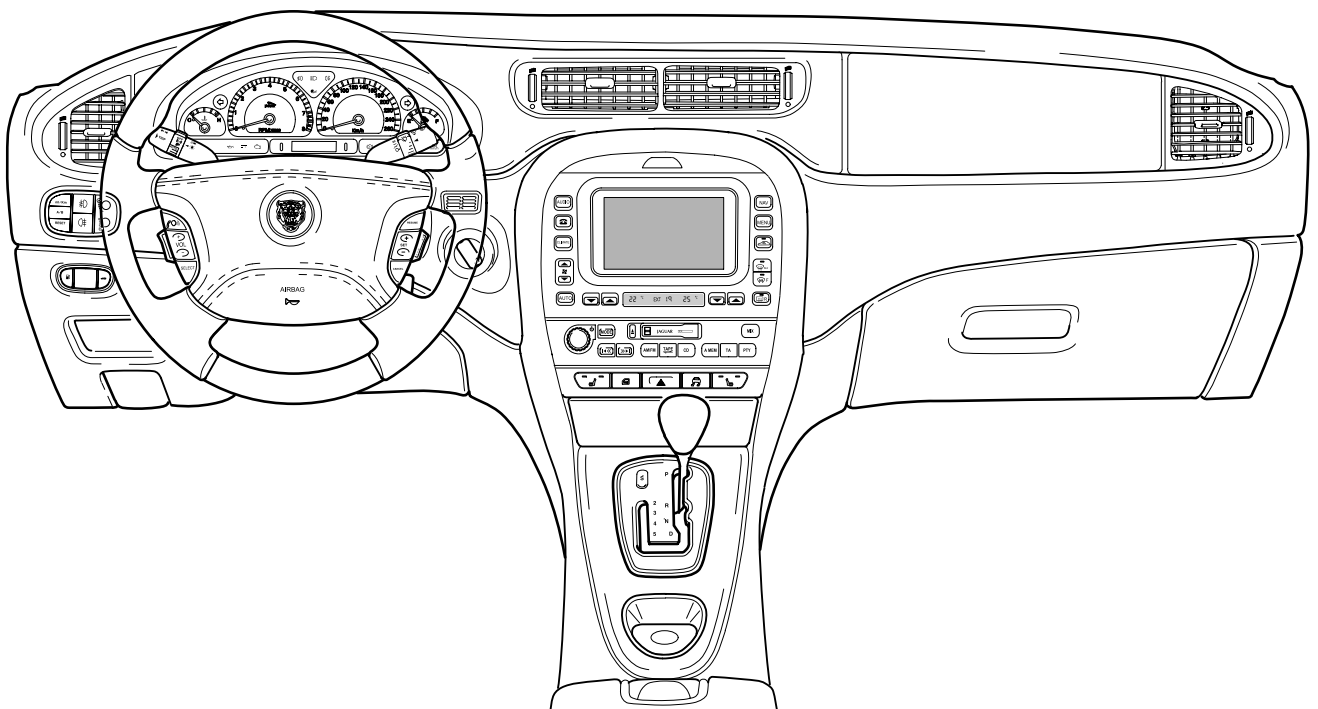





S-TYPE INSTRUMENT PANEL















NOTE: In the examples on this page, an 'X' is used where a number would appear on an actual Figure.

Reference Symbols

-  Battery power supply
-  Ignition switched auxiliary power supply (key I, II)
-  Ignition switched power supply (key II, III)
-  Switched System Power Supply power supply
-  Engine Management System power supply
-  Figure number reference
-  Controller Area Network
-  Standard Corporate Protocol network
-  D2B network





Control Module Pin Symbols

-  Input
-  Output
-  Battery voltage
-  Power ground
-  Sensor/signal supply V *
-  Sensor/signal ground **
-  CAN network
-  SCP network
-  D2B network
-  Serial and encoded data

* May also indicate Reference Voltage.

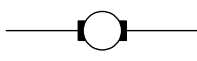
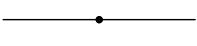
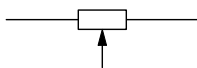
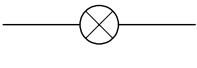
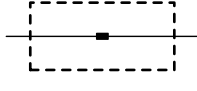
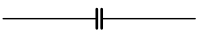
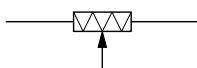
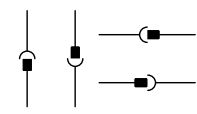
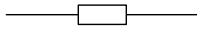
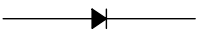
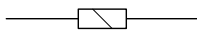
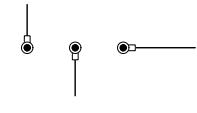
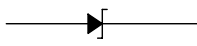
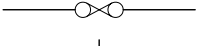
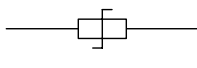
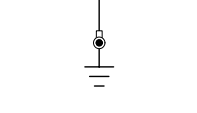
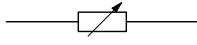
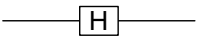
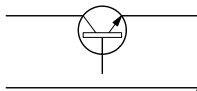
** May also indicate Reference Ground or Logic Ground.
Refer to Control Module Pin-Out Information.

Wiring Symbols

- | | | | |
|----------------------------|---|--|---------------------------------|
| Splice |  |  | Motor |
| Simplified splice |  |  | Potentiometer |
| Bulb |  |  | Power distribution box terminal |
| Capacitor |  |  | Pressure transducer |
| Connector |  |  | Resistor |
| Diode |  |  | Solenoid |
| Eyelet and stud |  |  | Suppression diode |
| Fuse |  |  | Suppression resistor |
| Ground |  |  | Thermistor |
| Hall effect sensor |  |  | Transistor |
| Light emitting diode (LED) |  |  | Wire continued |
| | |  | Zener diode |

**Harness Codes**

AC	Climate Control Link
AT	Alarm Link
BF	Front Fog Lamp Harness
BR	Rear Bumper Harness
CA	Cabin Harness
CP	Intercooler Pump Link
CV	Canister Vent Link
DD	Driver Door Harness
DM	Driver Memory Seat Harness
DT	Driver Door Trim Link
FC	Fascia Harness
FH	Front Harness
FL	LH Front Headlamp Link
FP	Fuel Pump Harness
FR	RH Front Headlamp Link
GB	Transmission Harness
IL	Fuel Injector Link
PD	Passenger Door
PI	Engine Harness
PN	Passenger Seat Harness
PT	Passenger Door Trim Link
RA	D2B Network Harness
RF	Roof Harness
SL	Solar Sensor Link
SR	Sliding Roof Harness
SW	Subwoofer Link
TT	Trailer Tow Harness

Wiring Color Codes

N	Brown	O	Orange
B	Black	S	Slate
W	White	L	Light
K	Pink	U	Blue
G	Green	P	Purple
R	Red	BRD	Braid
Y	Yellow	BOF	Black fiber optic (D2B Network)

Code Numbering

When numbering connectors, grounds and splices, Jaguar Engineering uses a three-position format: CA001, CA002, etc. Because space is limited in this Electrical Guide the codes have, in most cases, been shortened. Thus CA001-001 becomes CA1-1, CA002-001 becomes CA2-1, etc.



Grounds

On figures where LHD and RHD circuits are combined and the ground designation differs from LHD to RHD, the RHD ground code is shown in parentheses. If the ground designation is the same for LHD and RHD, only one ground code is used, with no parentheses.



Relays

All relays are located in the Front and Rear Power Distribution Boxes and the Primary Junction Fuse Box. Relays do not have a separate relay connector (base). All relays use the ISO pin numbering system (1, 2, 3, 4, 5). Each relay is identified by an “R” number unique only to the fuse box in which it is located.

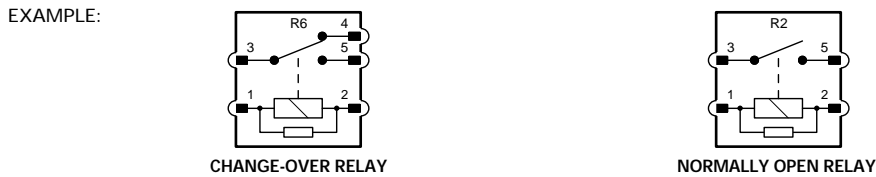

Fuses

All fuses are located in the Front and Rear Power Distribution Boxes and the Primary Junction Fuse Box. Each fuse is identified by an “F” number unique only to the fuse box in which it is located.

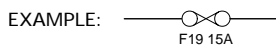

Networks

In most instances, networks are shown as a broken grey line to indicate that there is network communication between the depicted control modules. Refer to Figures 20.1, 20.2, 20.3, 20.4 and 20.5 for circuit details.

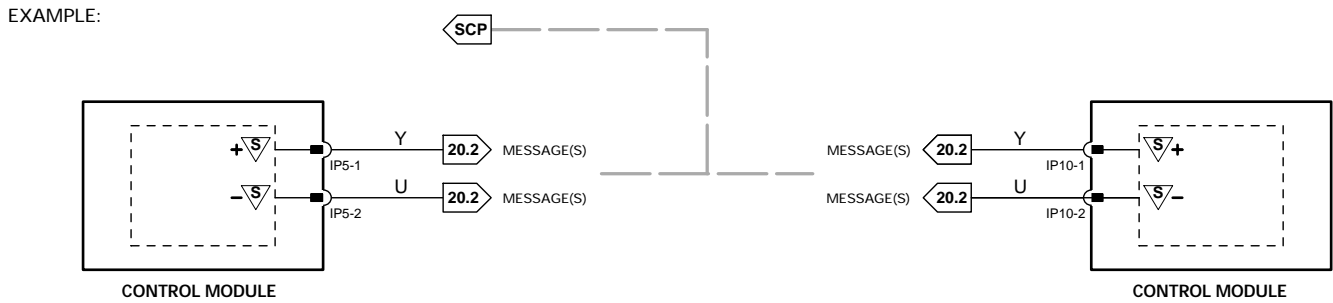

Component Depictions

EXAMPLE:

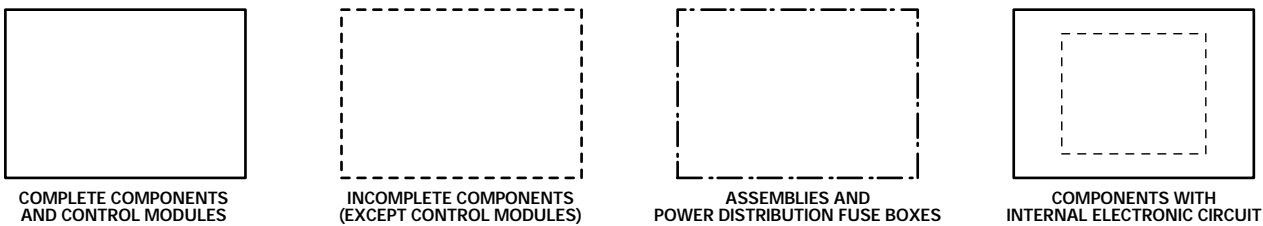

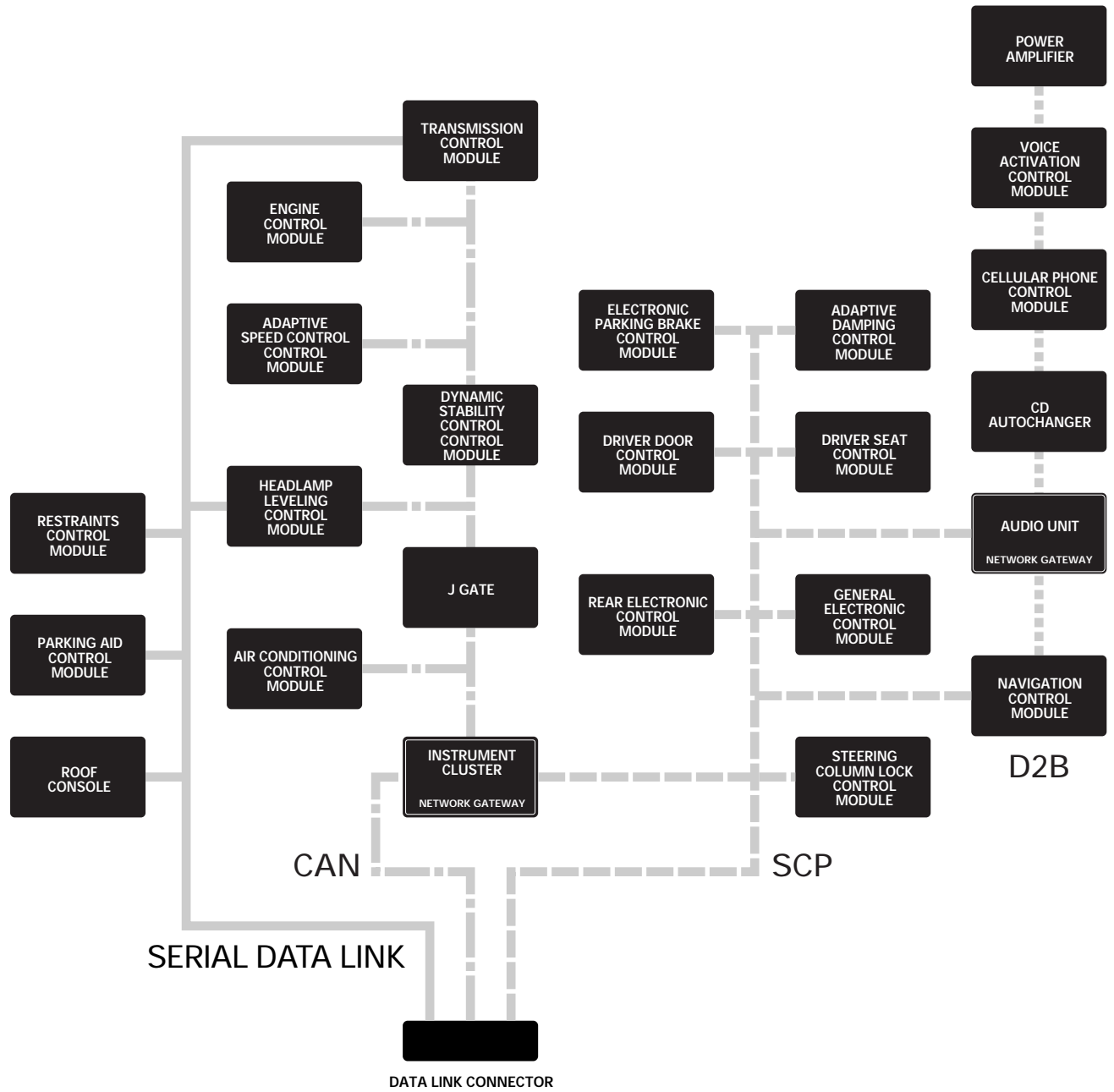

- CAN NETWORK
- . - . - . SCP NETWORK
- D2B NETWORK
- SERIAL DATA LINK

NOTE: TYPICAL S-TYPE NETWORK CONFIGURATION (AUTOMATIC TRANSMISSION; FULL OPTION SET). REFER TO FIGURES 20.1, 20.2, 20.3, 20.4 AND 20.5 FOR CIRCUIT DETAILS.

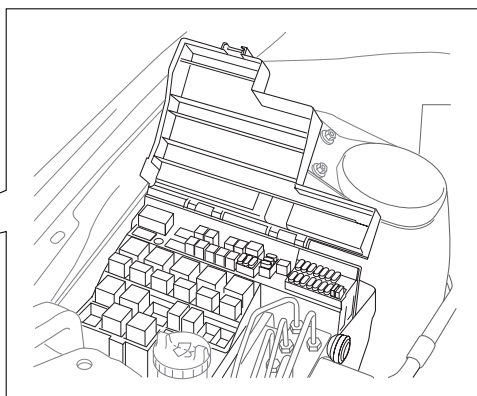
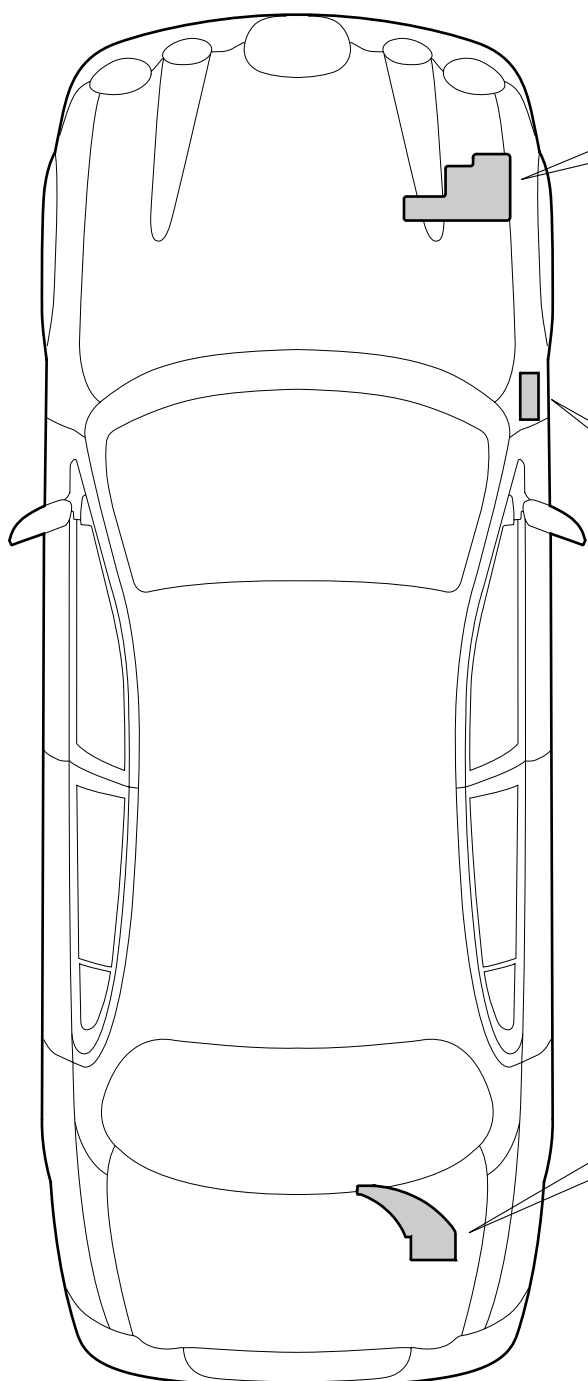

FRONT POWER DISTRIBUTION BOX

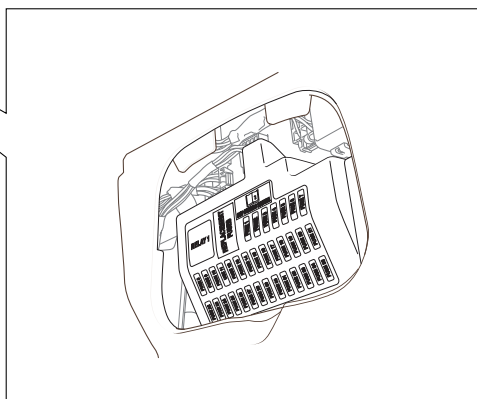

PRIMARY JUNCTION FUSE BOX

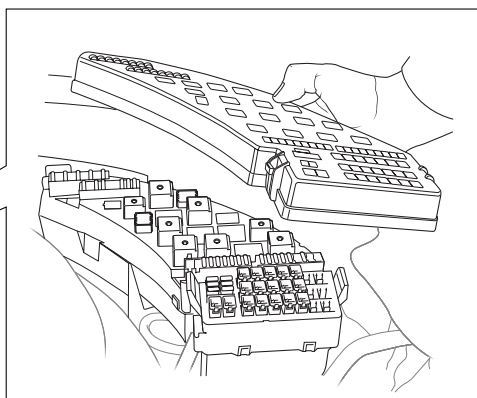

REAR POWER DISTRIBUTION BOX



FRONT POWER DISTRIBUTION BOX

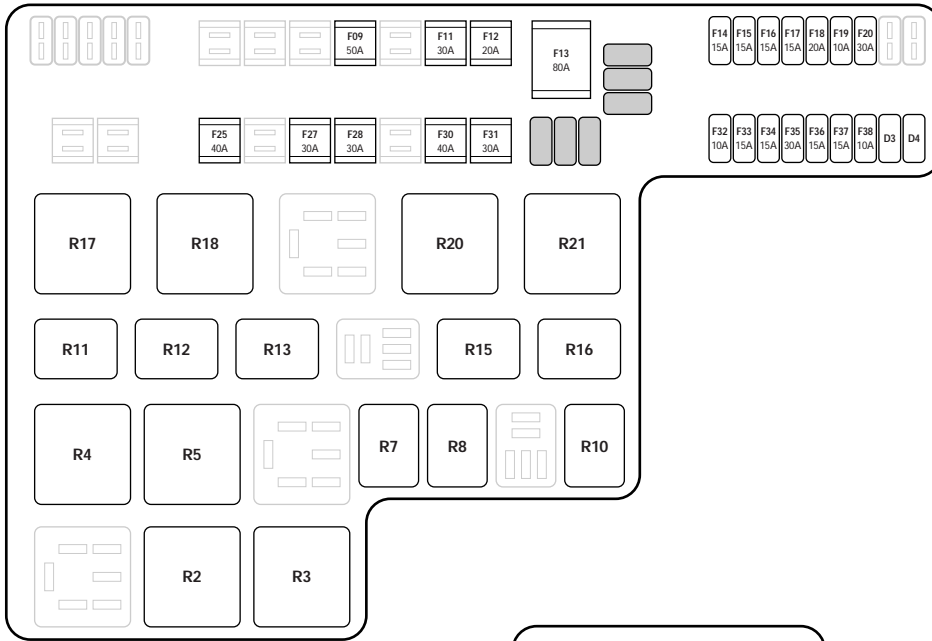

- R2 HEATED OXYGEN SENSOR RELAY
- R3 IGNITION COIL RELAY
- R4 THROTTLE MOTOR RELAY
- R5 EMS CONTROL RELAY
- R7 AUXILIARY COOLANT PUMP RELAY
- R8 A/C COMPRESSOR CLUTCH RELAY
- R10 LH HID RELAY
- R11 FRONT FOG LAMP RELAY
- R12 HORN RELAY
- R13 RH HID RELAY
- R15 WIPER HIGH / LOW RELAY
- R16 WIPER PARK RELAY
- R17 LH WINDSHIELD HEATER RELAY
- R18 POWER WASH RELAY
- R20 STARTER RELAY
- R21 WIPER PARK HEATER RELAY OR RH WINDSHIELD HEATER RELAY

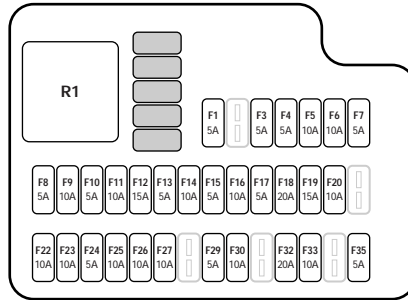

- R1 CIGAR LIGHTER / POWER POINT RELAY

PRIMARY JUNCTION FUSE BOX

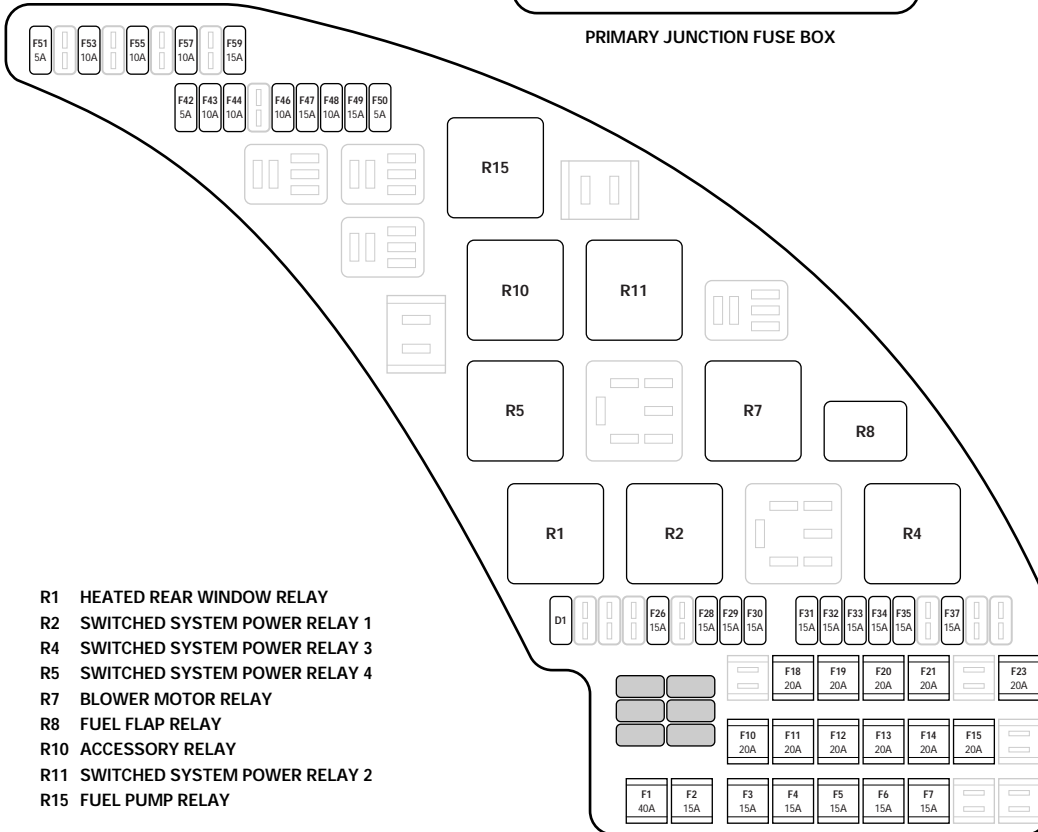

- R1 HEATED REAR WINDOW RELAY
- R2 SWITCHED SYSTEM POWER RELAY 1
- R4 SWITCHED SYSTEM POWER RELAY 3
- R5 SWITCHED SYSTEM POWER RELAY 4
- R7 BLOWER MOTOR RELAY
- R8 FUEL FLAP RELAY
- R10 ACCESSORY RELAY
- R11 SWITCHED SYSTEM POWER RELAY 2
- R15 FUEL PUMP RELAY

REAR POWER DISTRIBUTION BOX



LHD

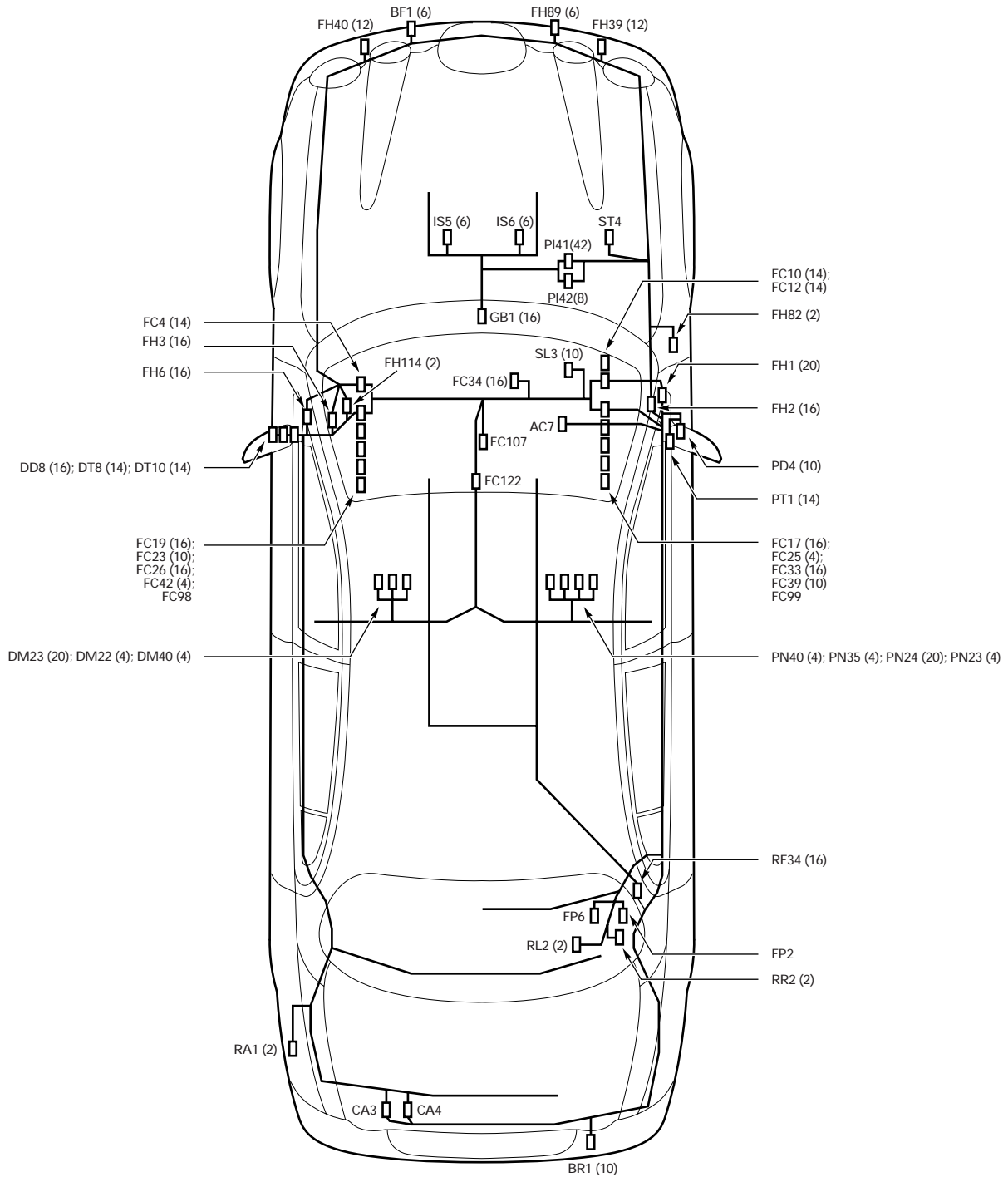

NOTE: WHERE THE INFORMATION IS AVAILABLE, THE NUMBER OF PINS CONTAINED IN A CONNECTOR IS SHOWN IN PARENTHESES.



RHD

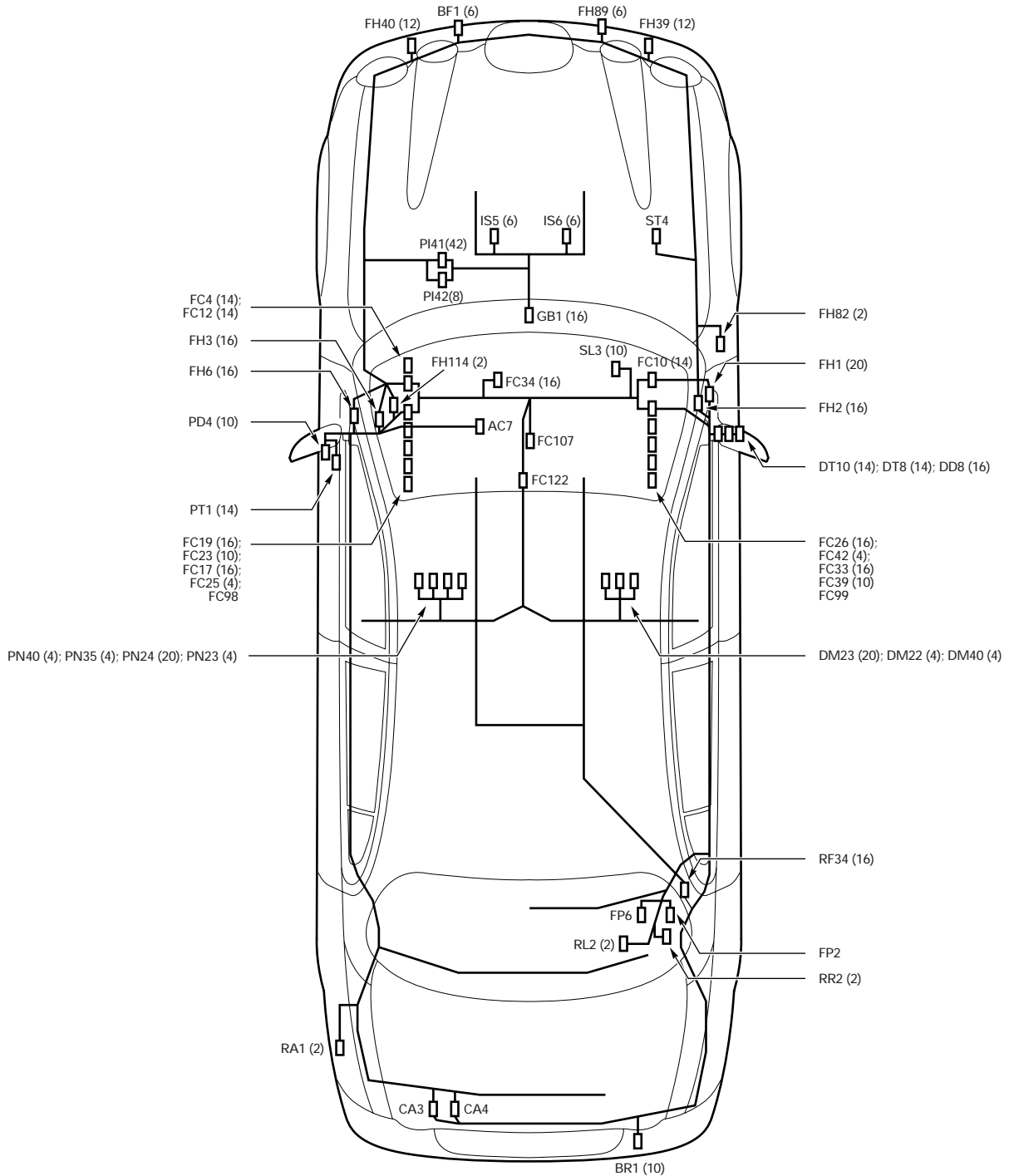

NOTE: WHERE THE INFORMATION IS AVAILABLE, THE NUMBER OF PINS CONTAINED IN A CONNECTOR IS SHOWN IN PARENTHESES.



LHD

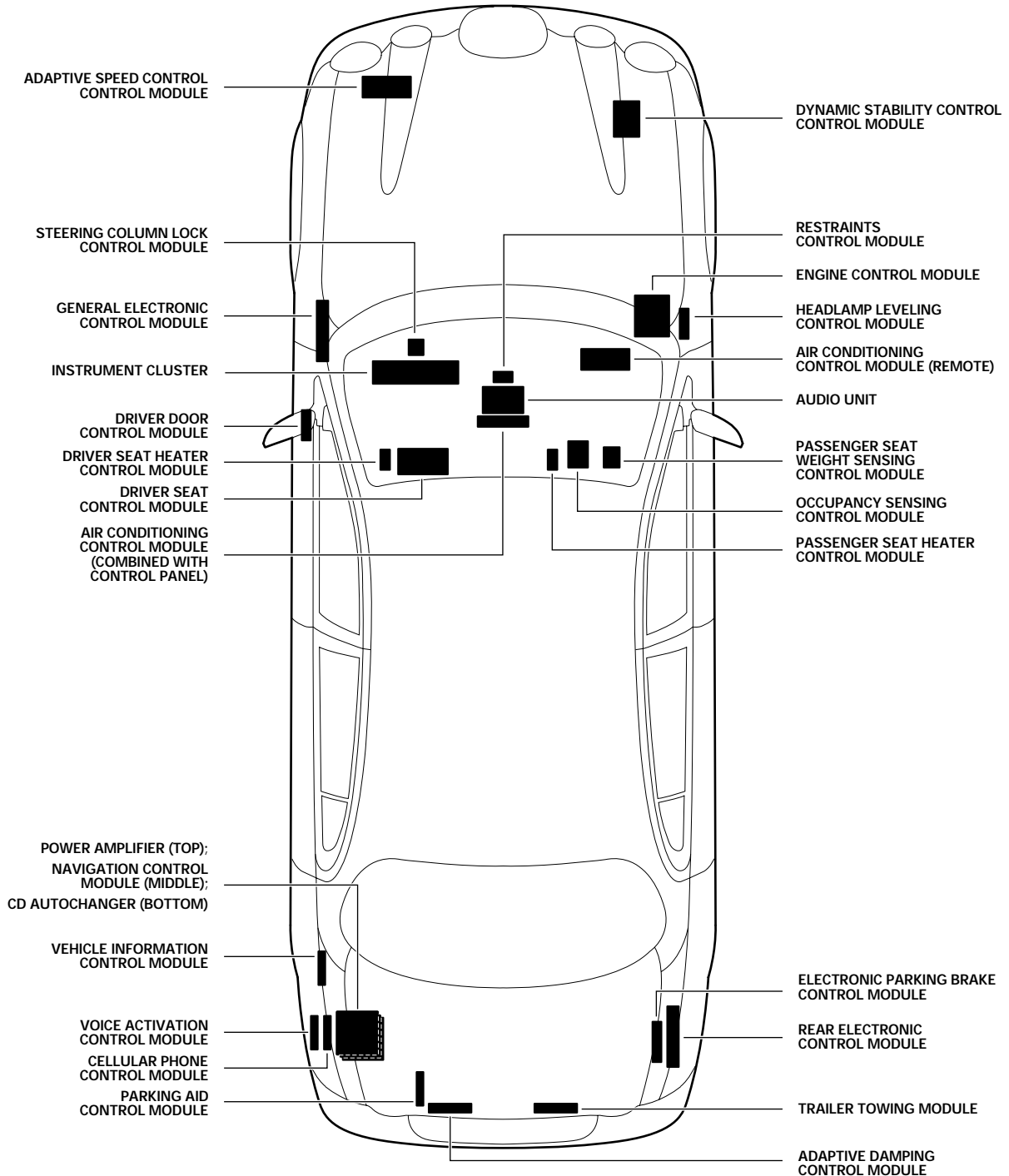

NOTE: THE TRANSMISSION CONTROL MODULE IS CONTAINED WITHIN THE TRANSMISSION.



RHD

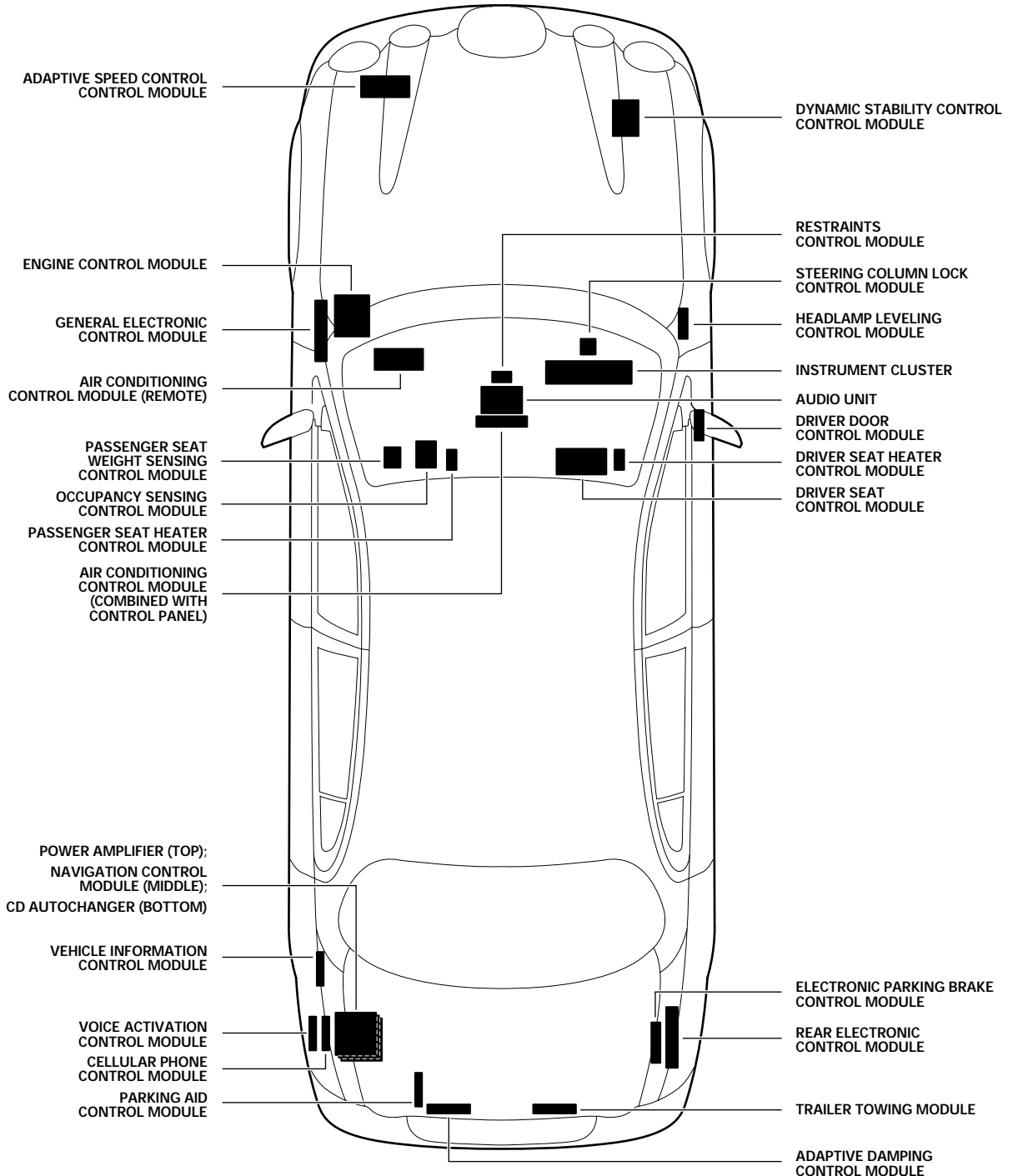

NOTE: THE TRANSMISSION CONTROL MODULE IS CONTAINED WITHIN THE TRANSMISSION.

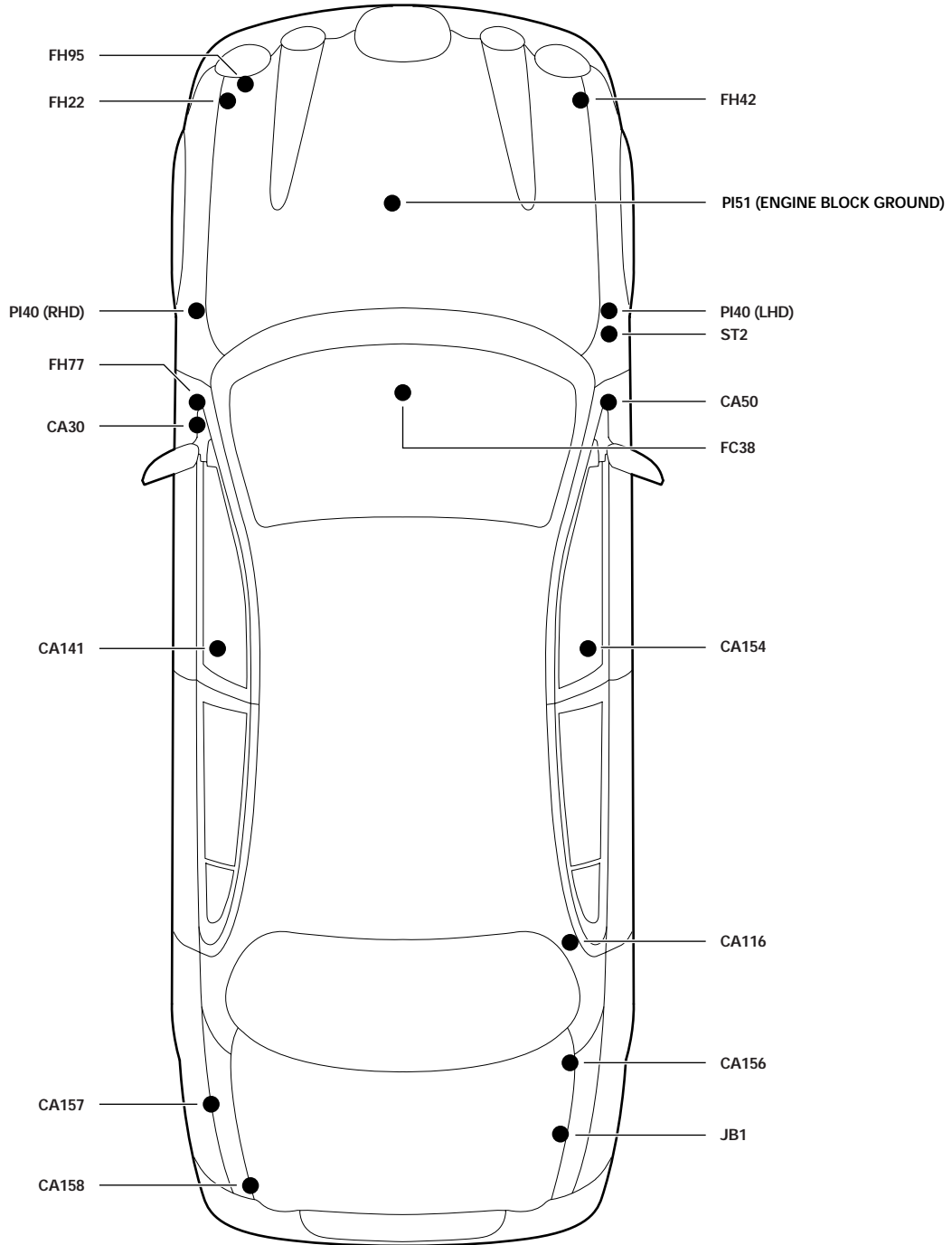

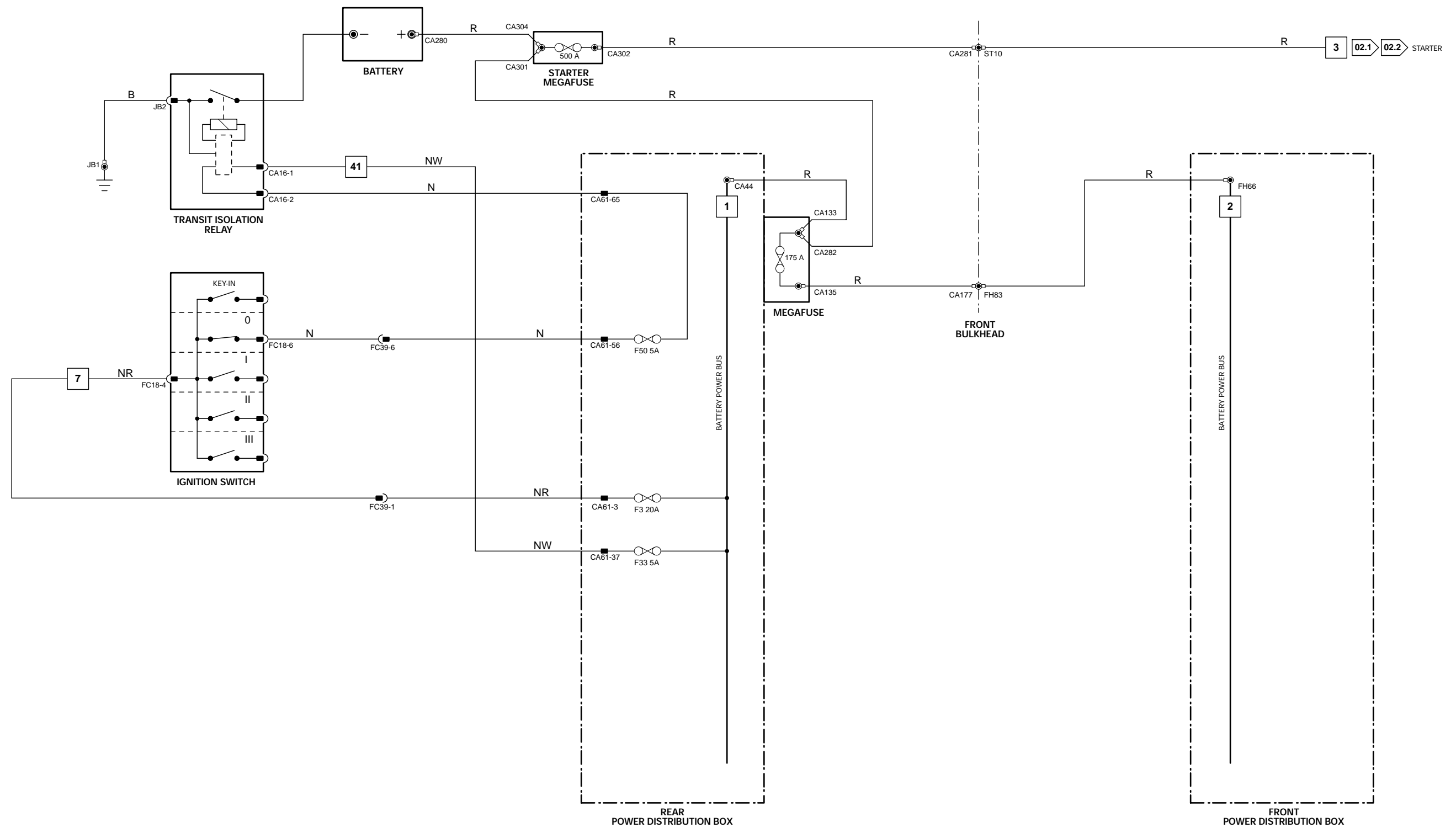

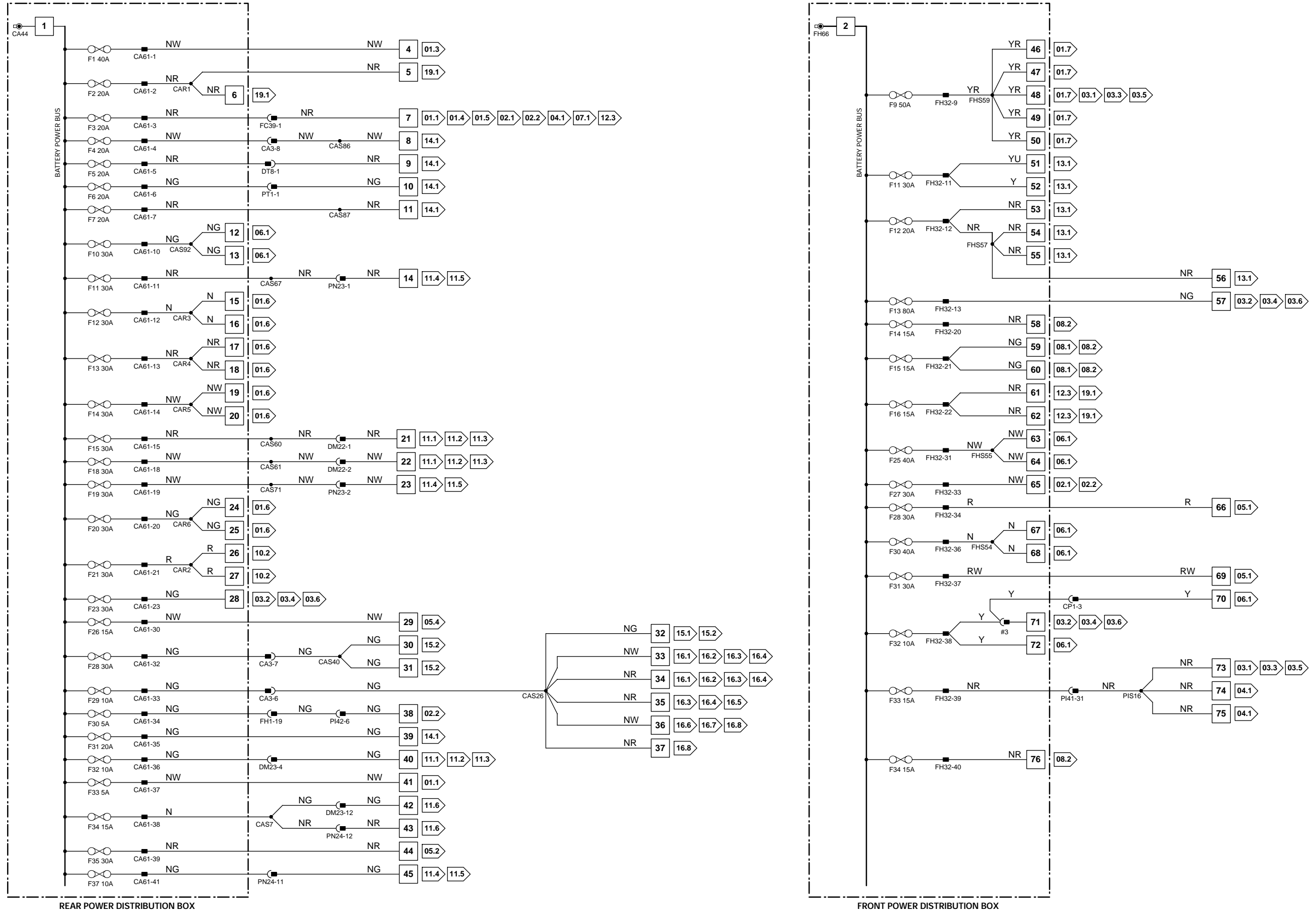

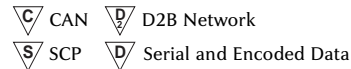
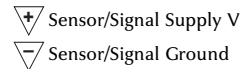
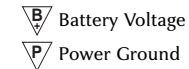
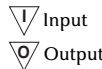
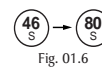
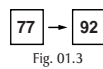
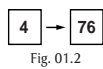
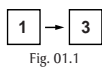
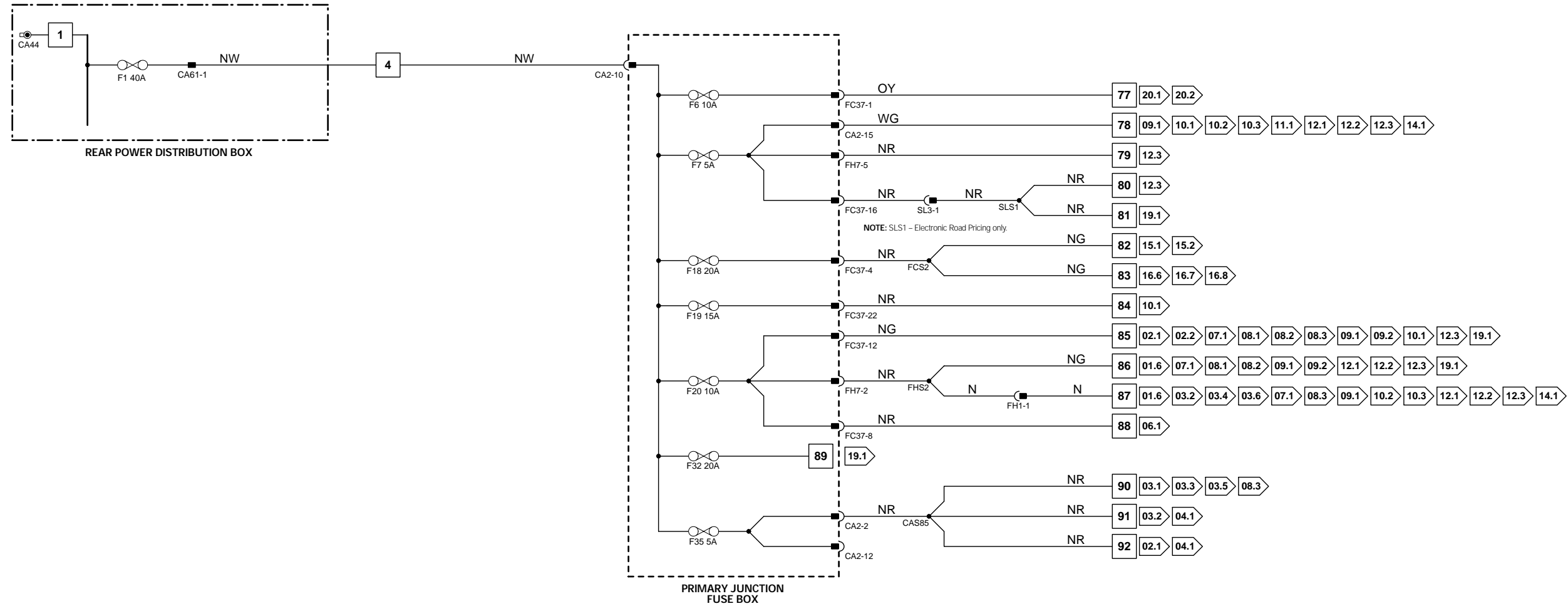

VARIANT: All Vehicles
VIN RANGE: All
DATE OF ISSUE: March 2002 (PROVISIONAL)

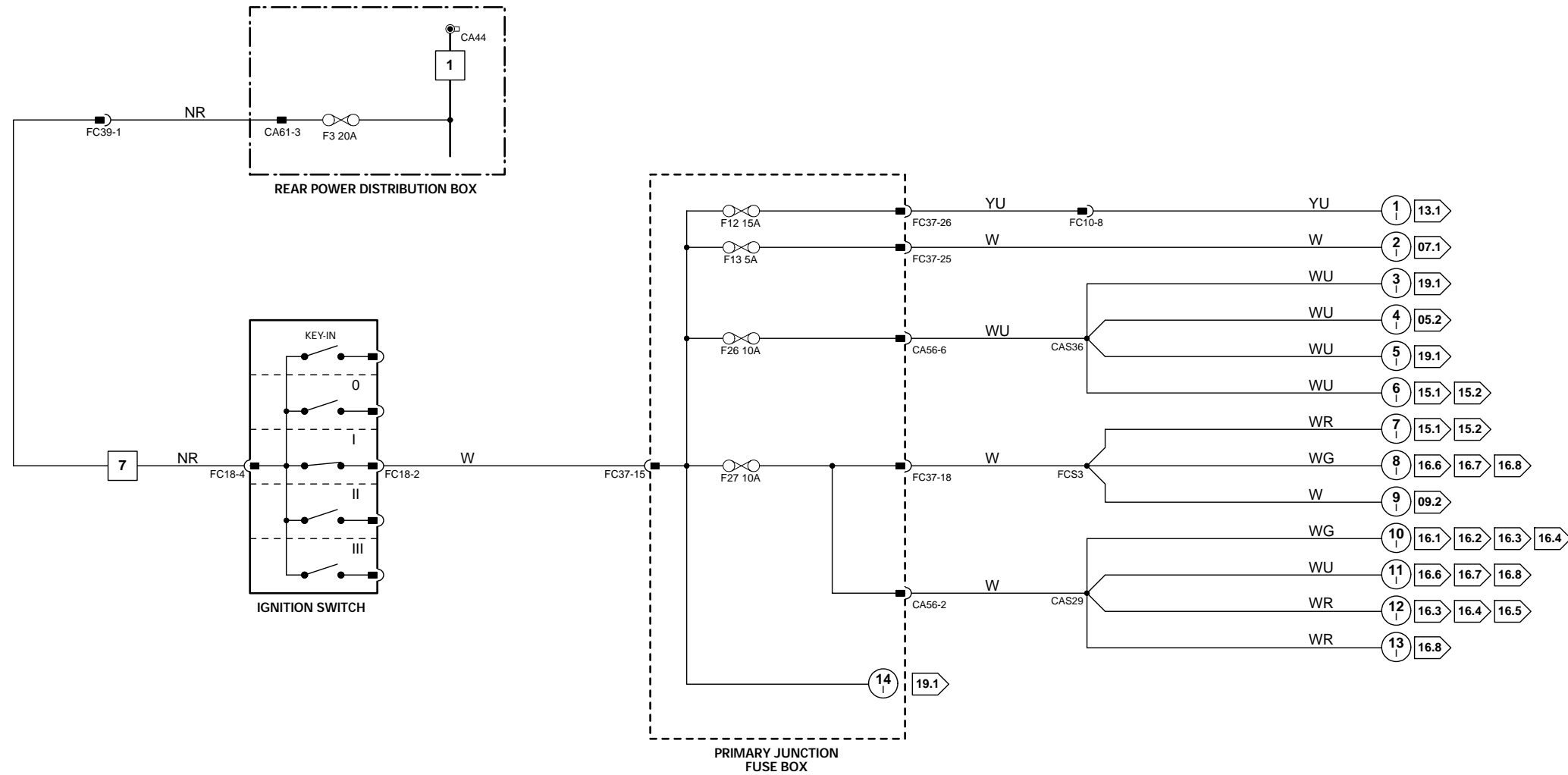

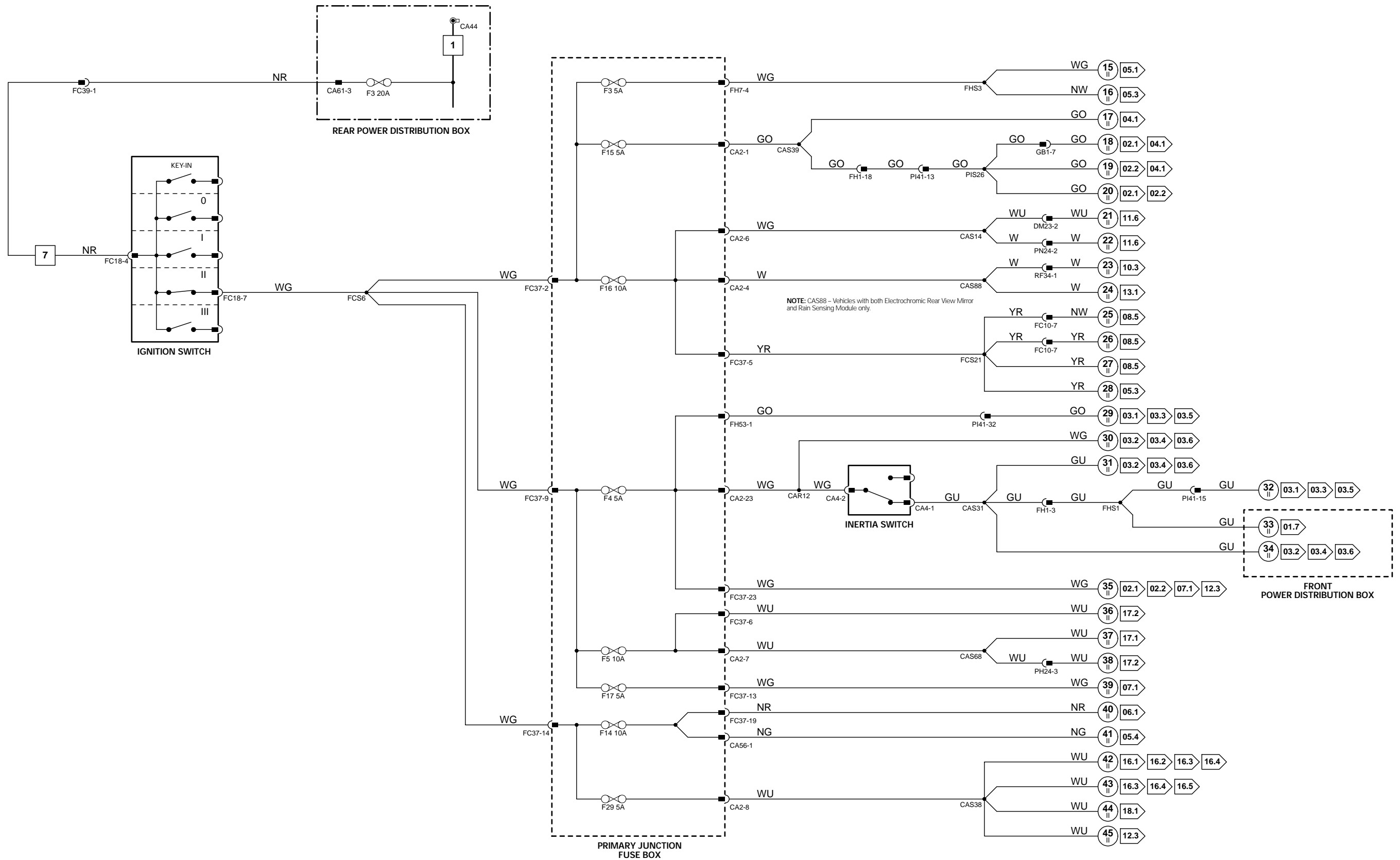

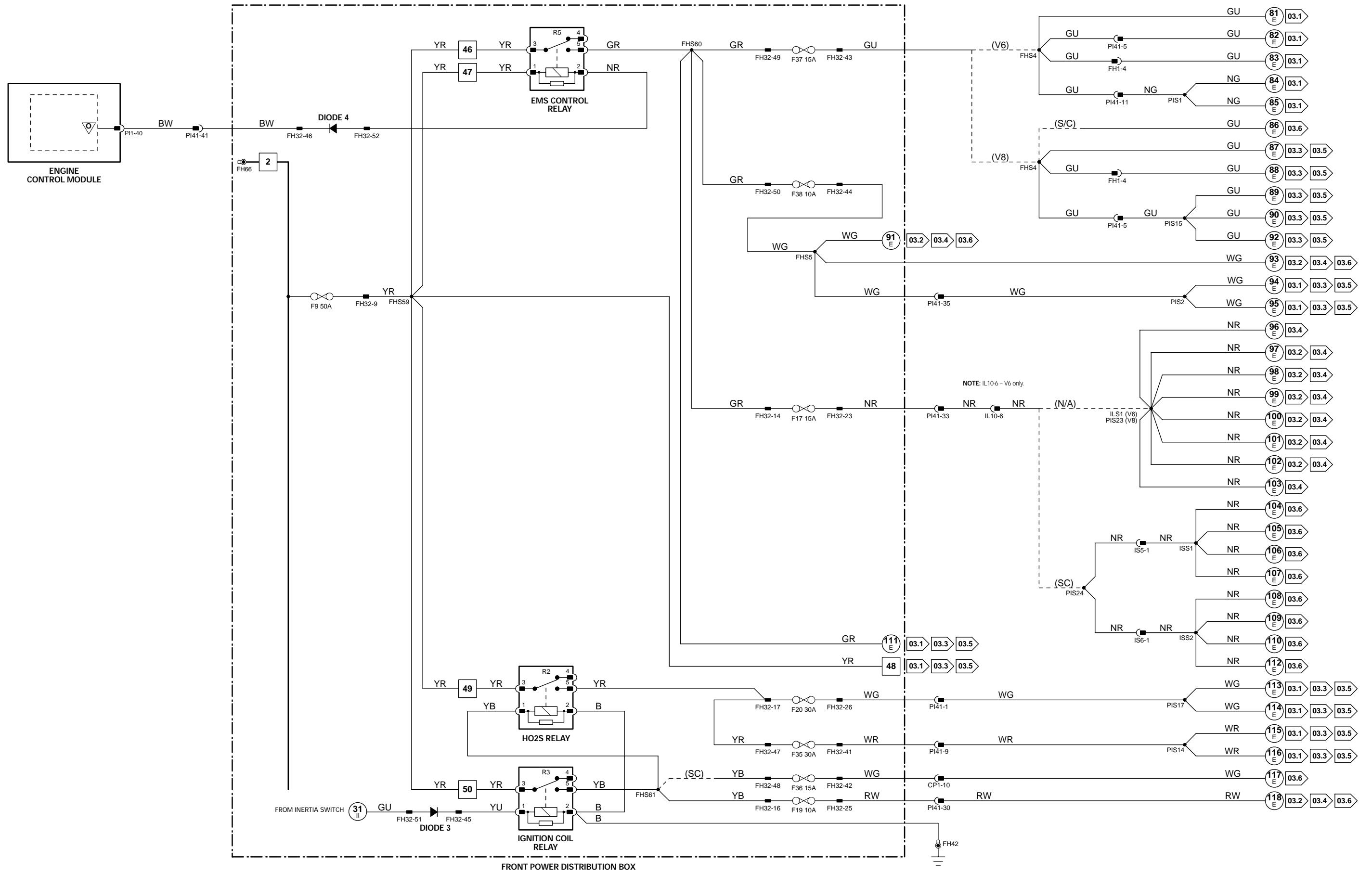

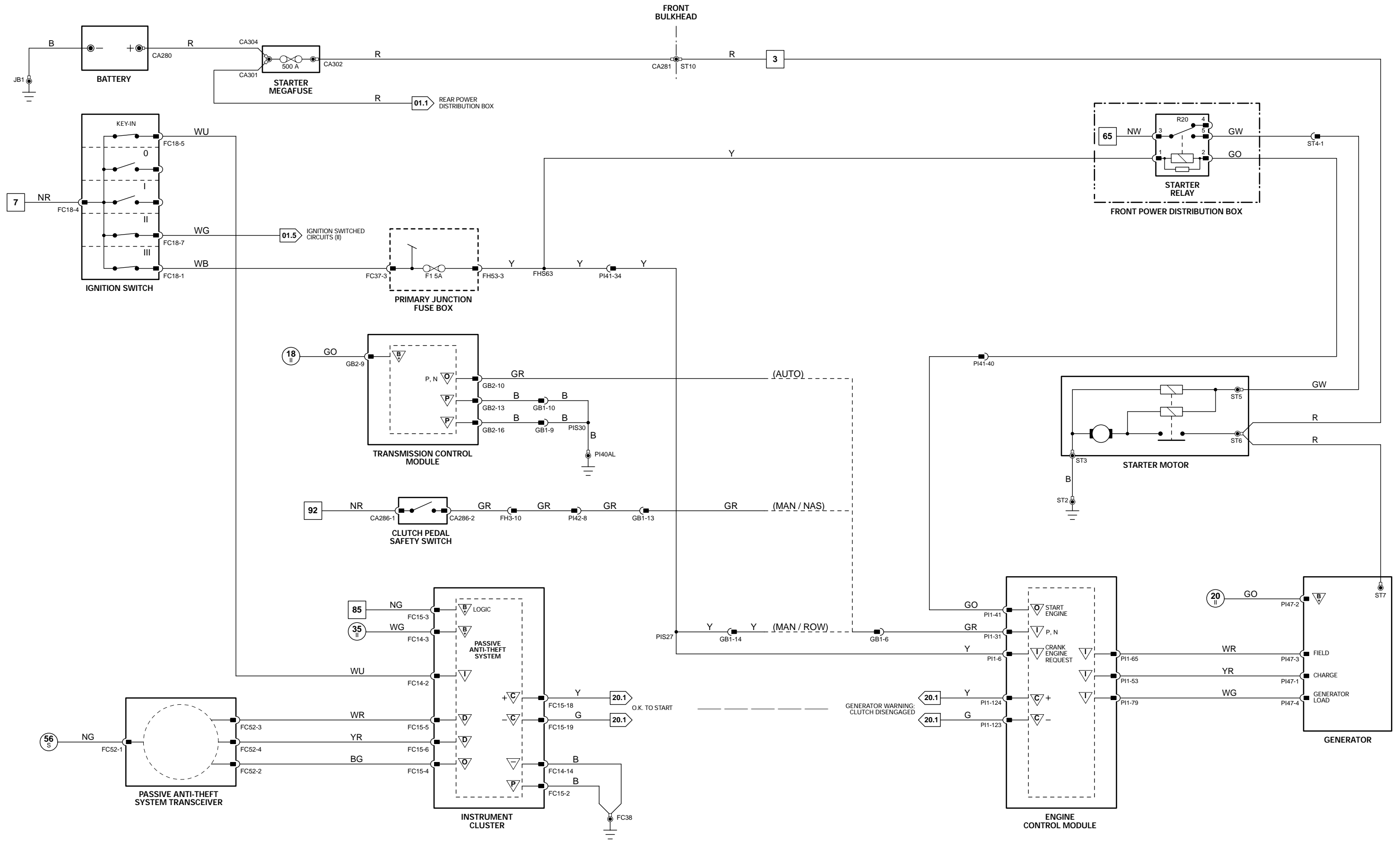

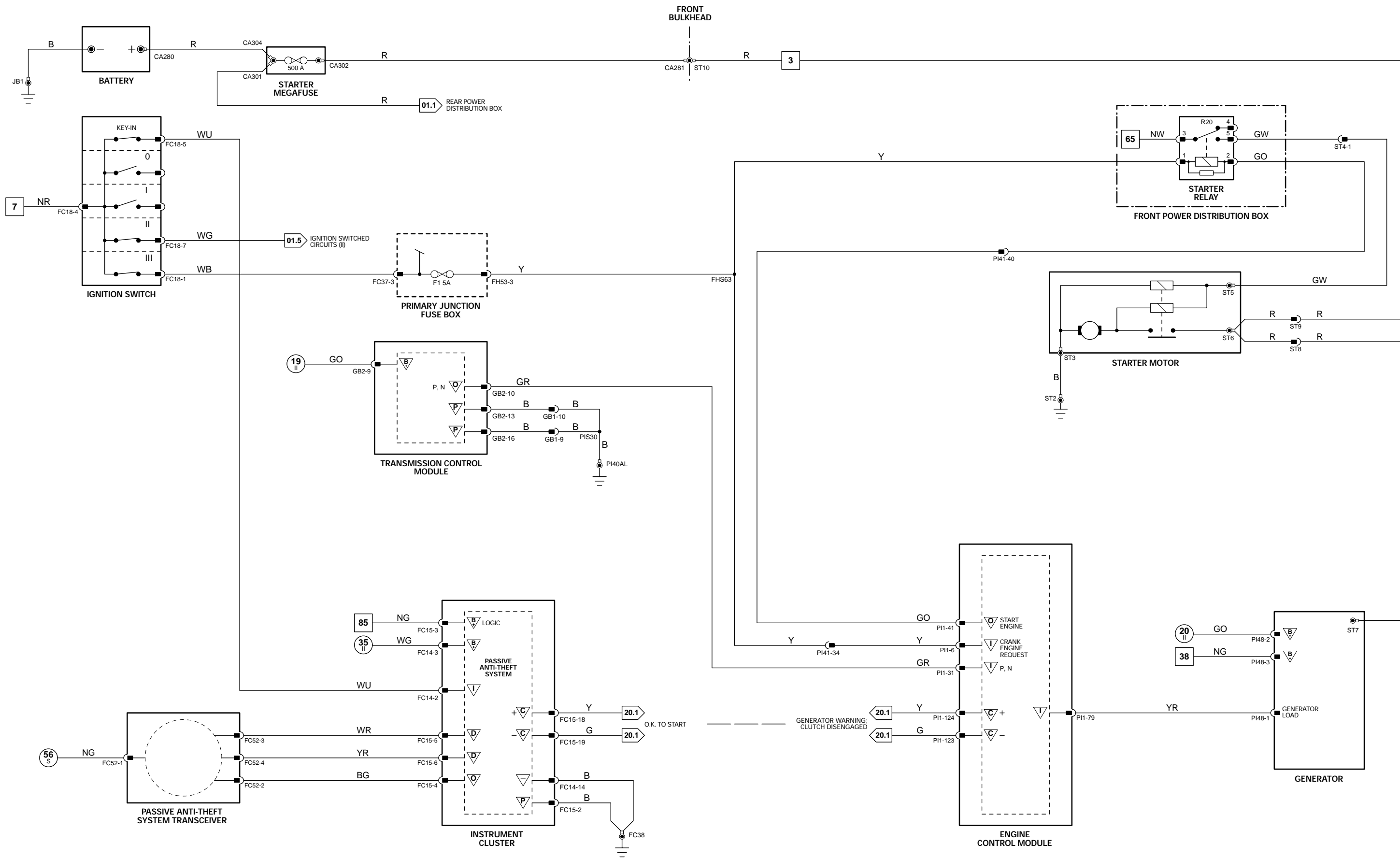

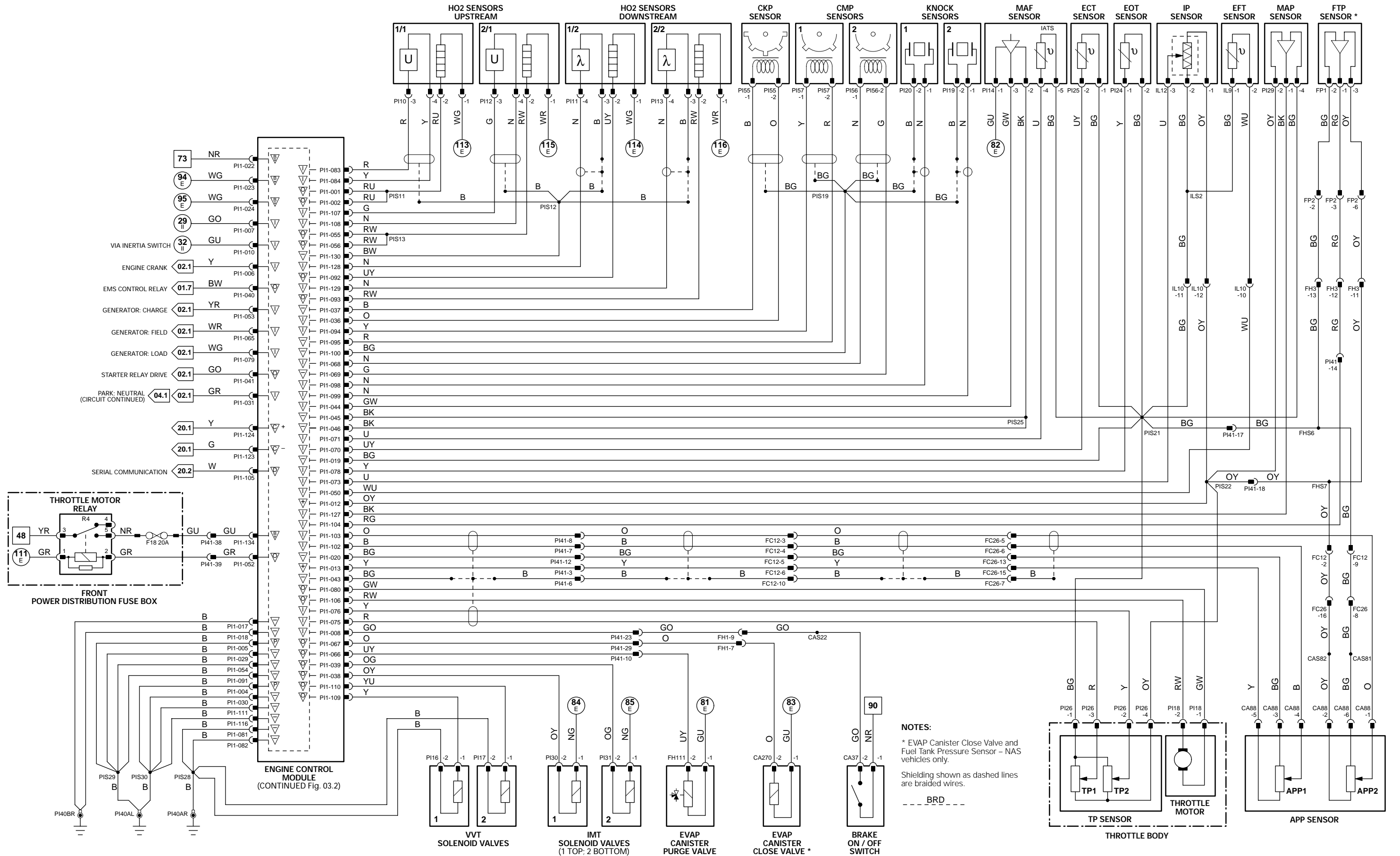

NOTES:
 * EVAP Canister Close Valve and Fuel Tank Pressure Sensor – NAS vehicles only.
 Shielding shown as dashed lines are braided wires.
 --- BRD ---

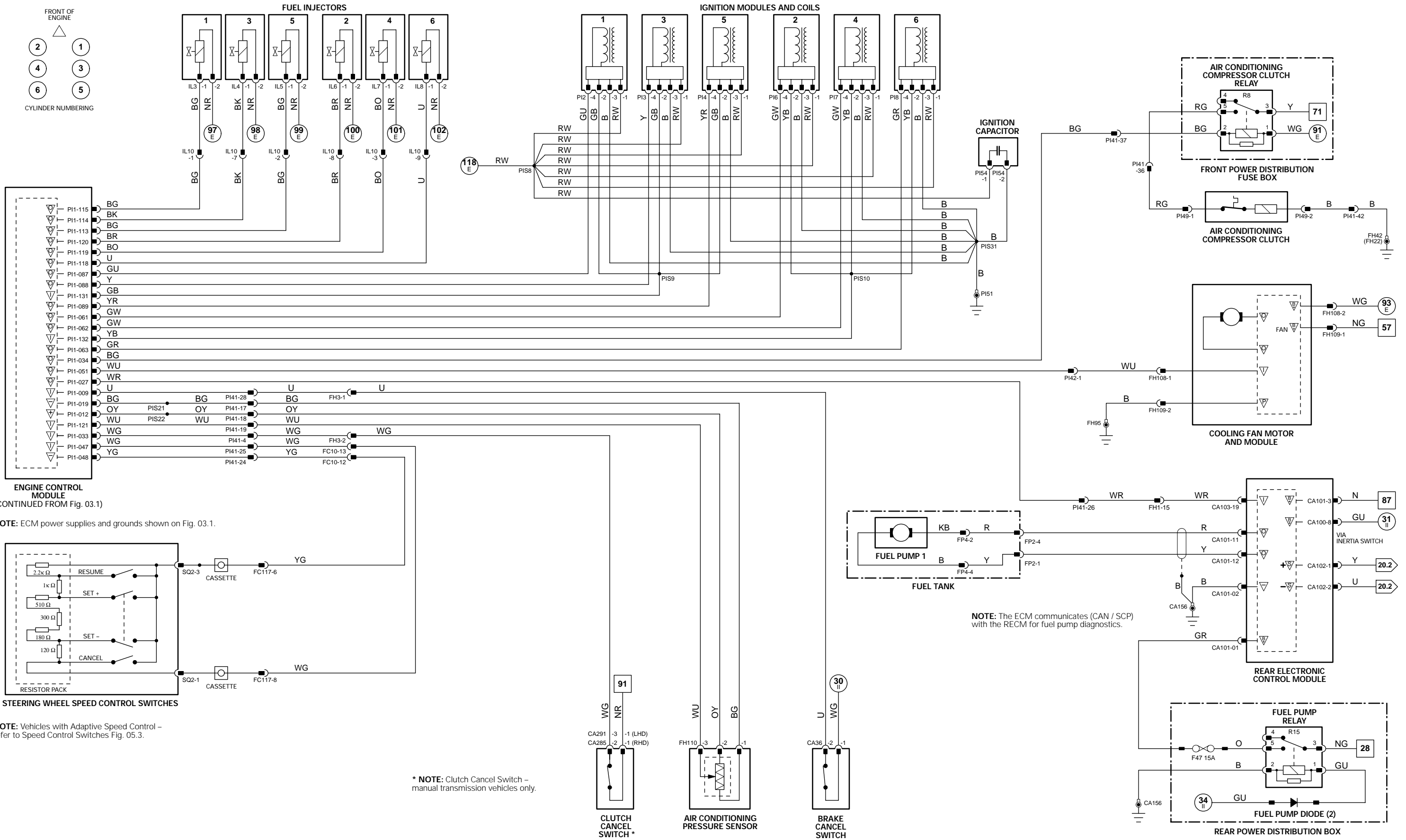

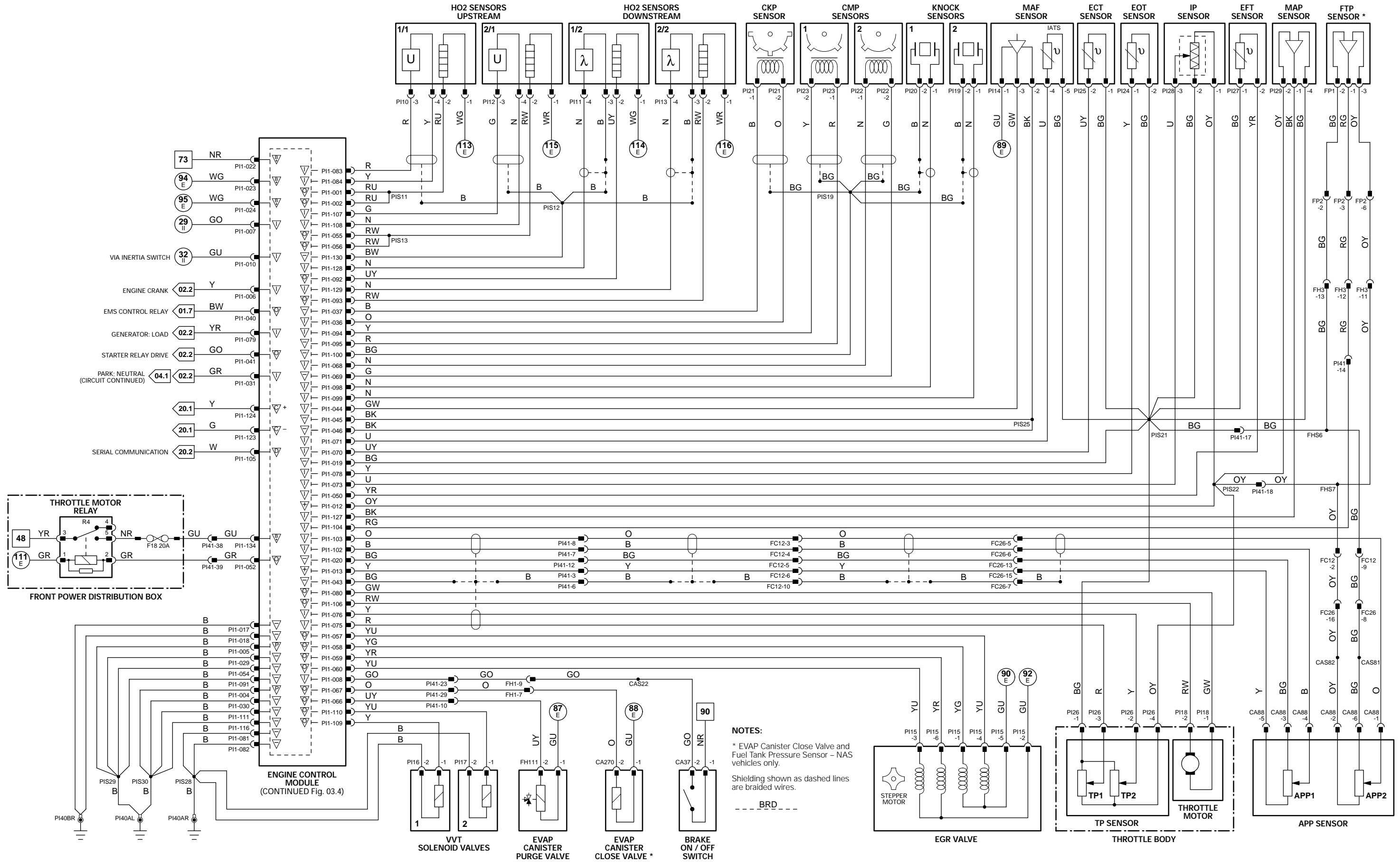

NOTES:

- * EVAP Canister Close Valve and Fuel Tank Pressure Sensor - NAS vehicles only.
- Shielding shown as dashed lines are braided wires.
- BRD

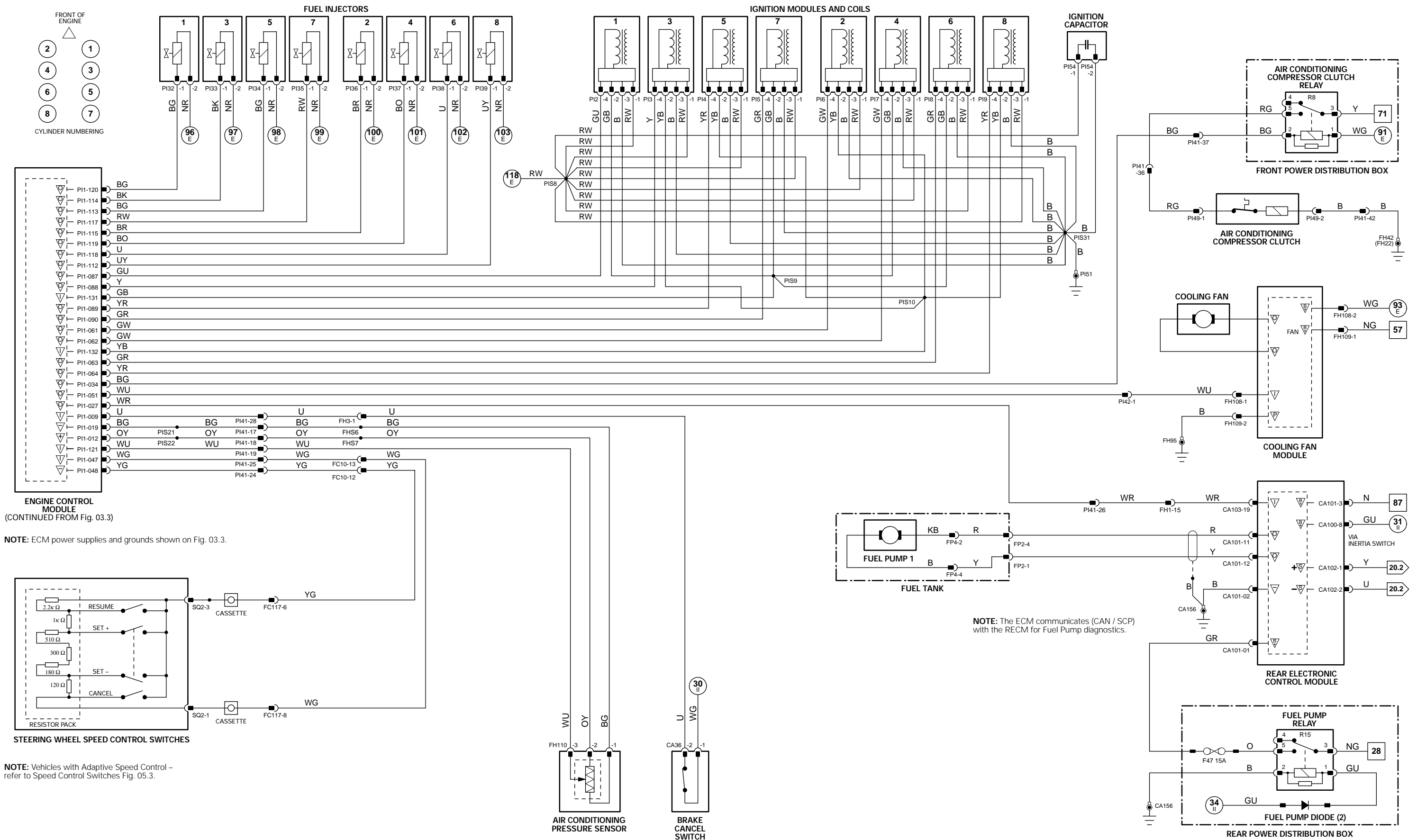

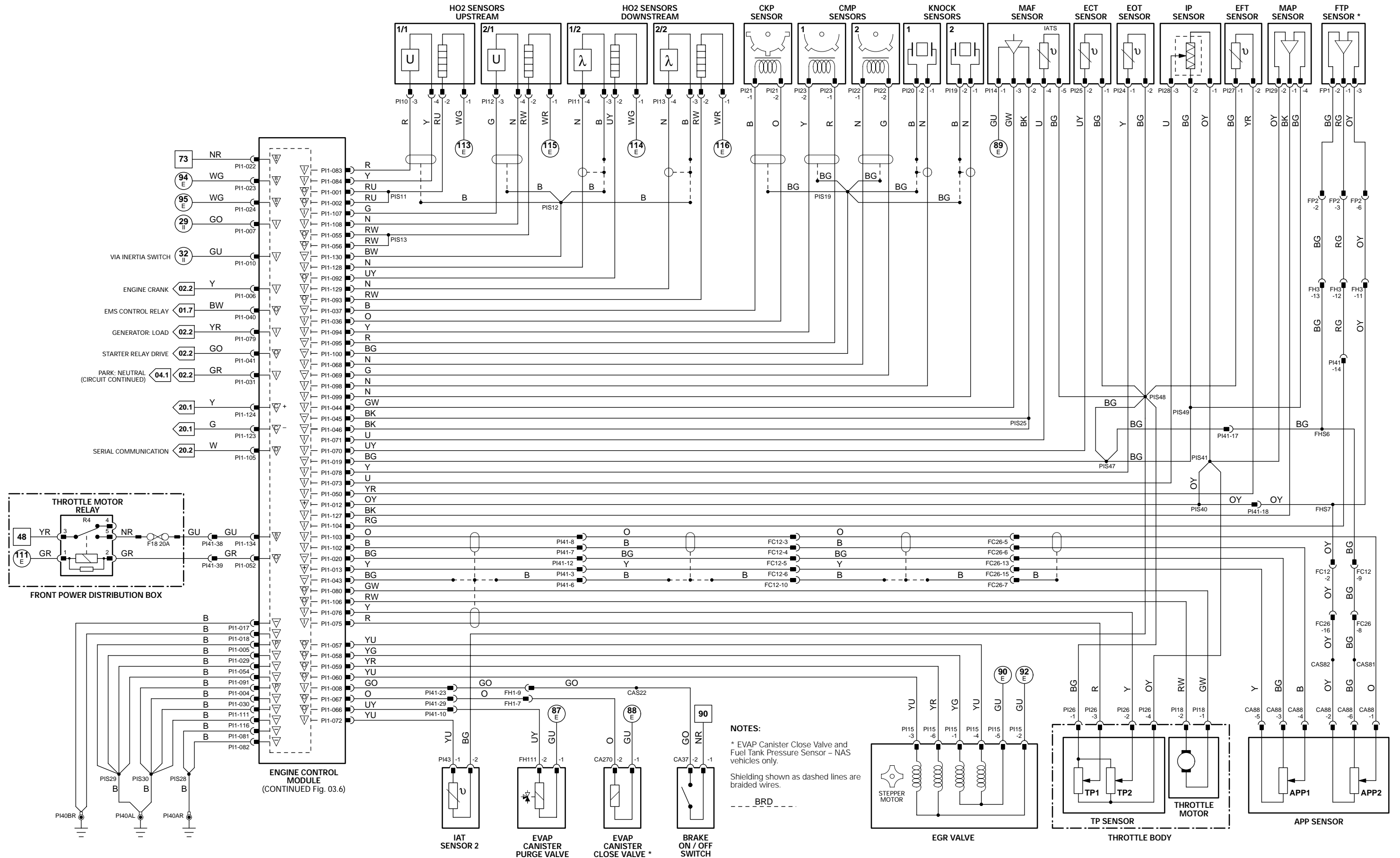

NOTES:

- * EVAP Canister Close Valve and Fuel Tank Pressure Sensor - NAS vehicles only.
- Shielding shown as dashed lines are braided wires.
- BRD

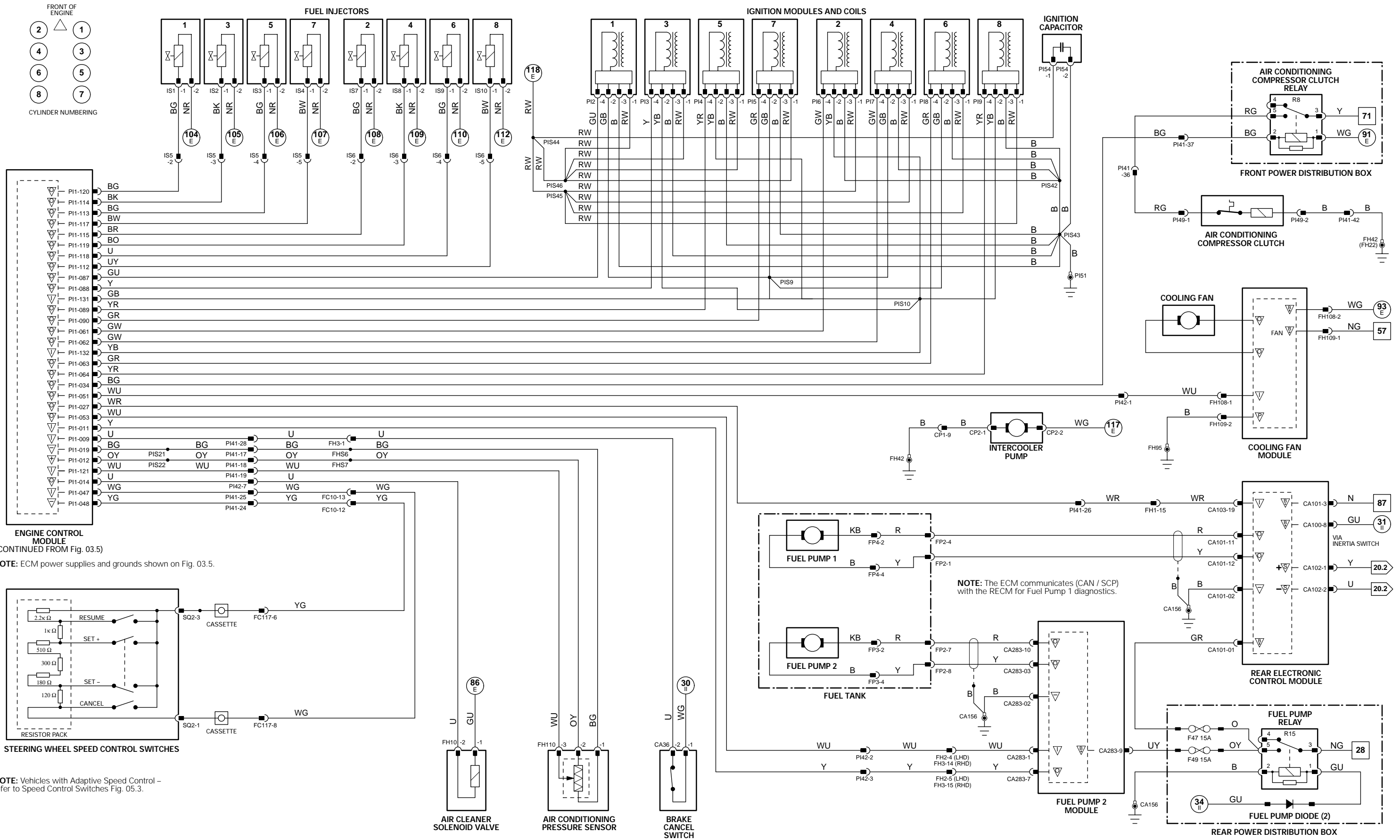

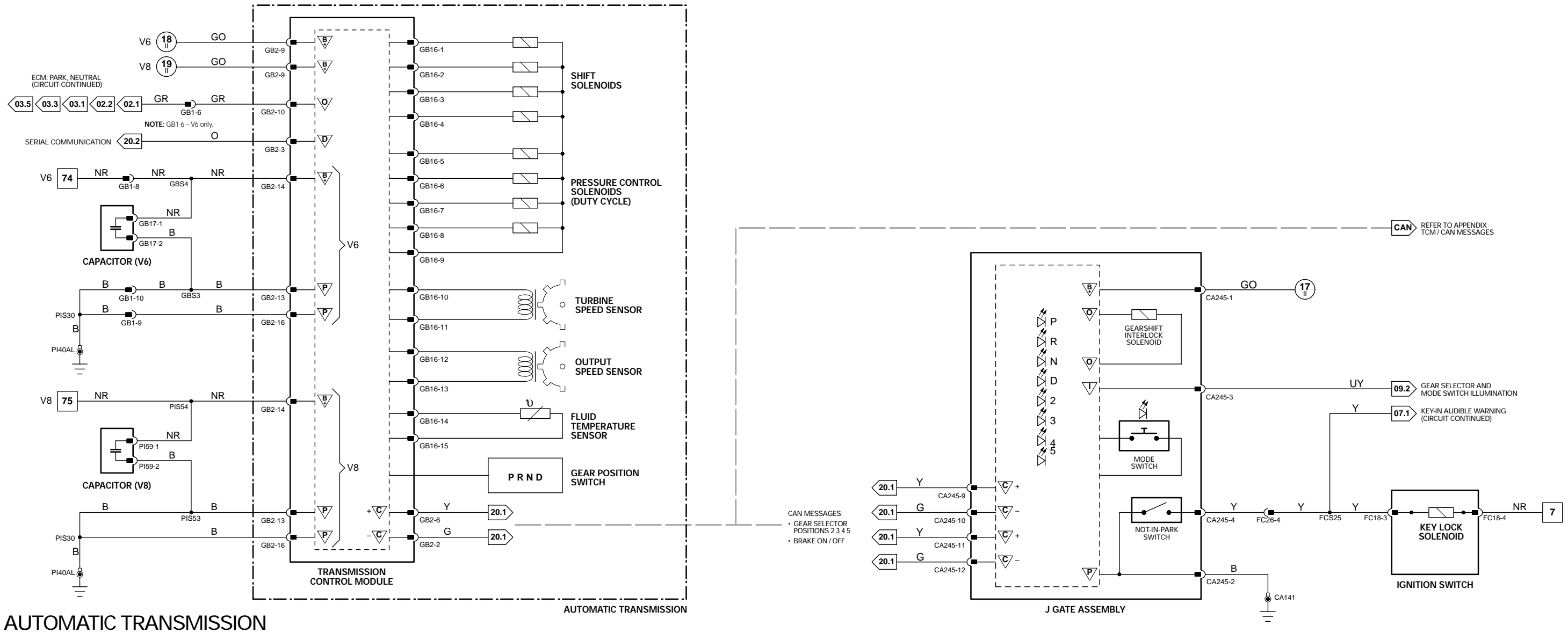

AUTOMATIC TRANSMISSION

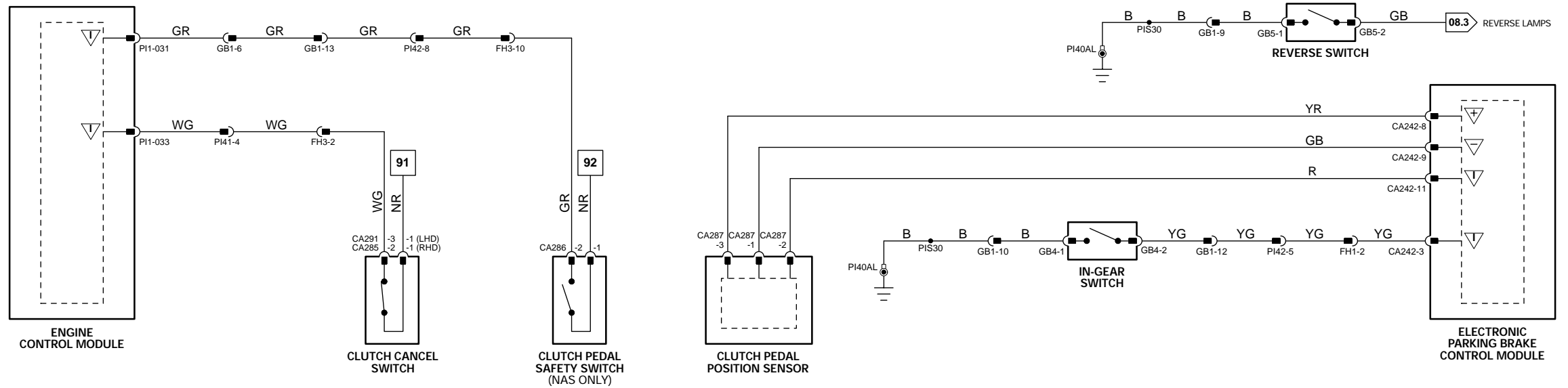

MANUAL TRANSMISSION

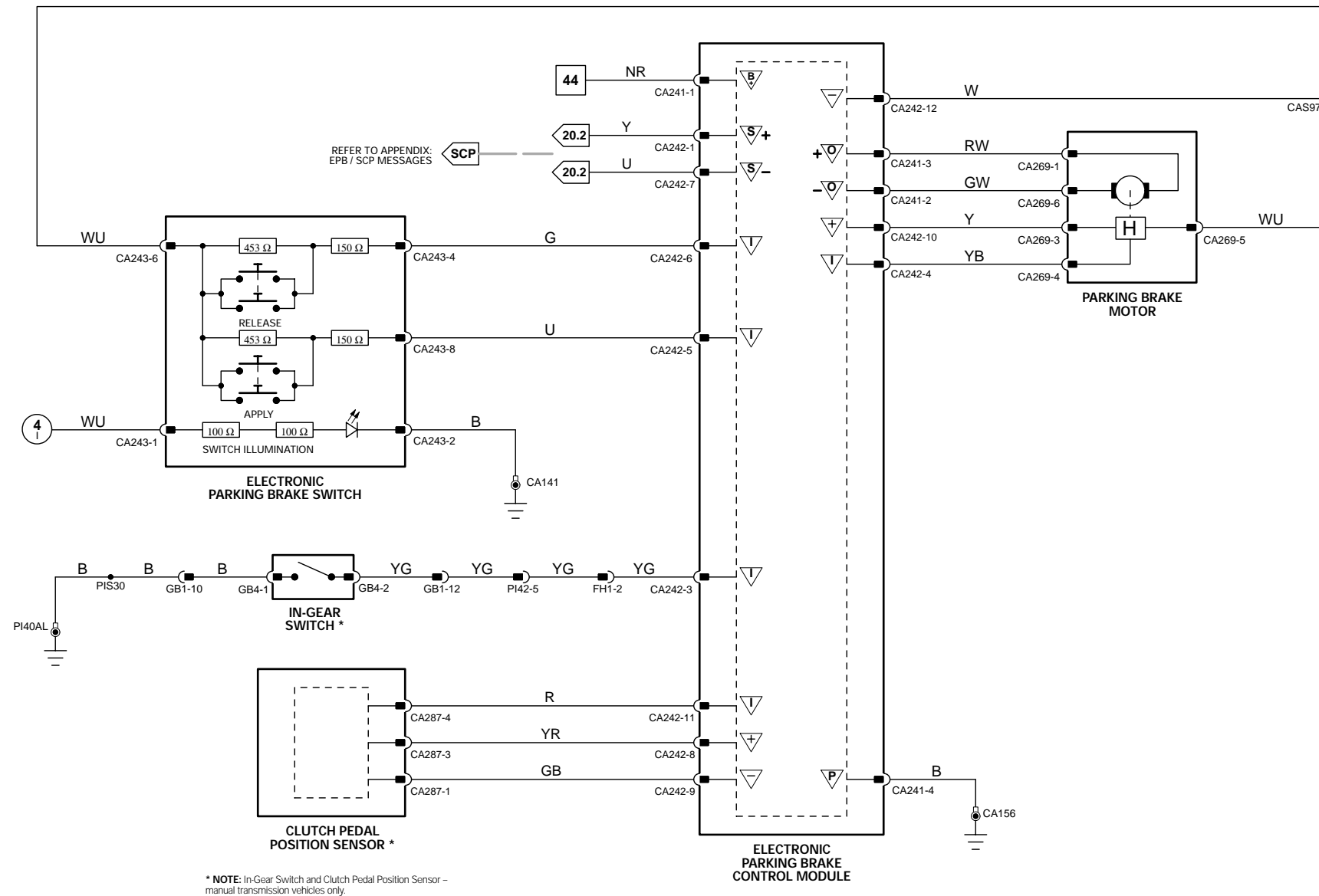

ELECTRONIC PARKING BRAKE

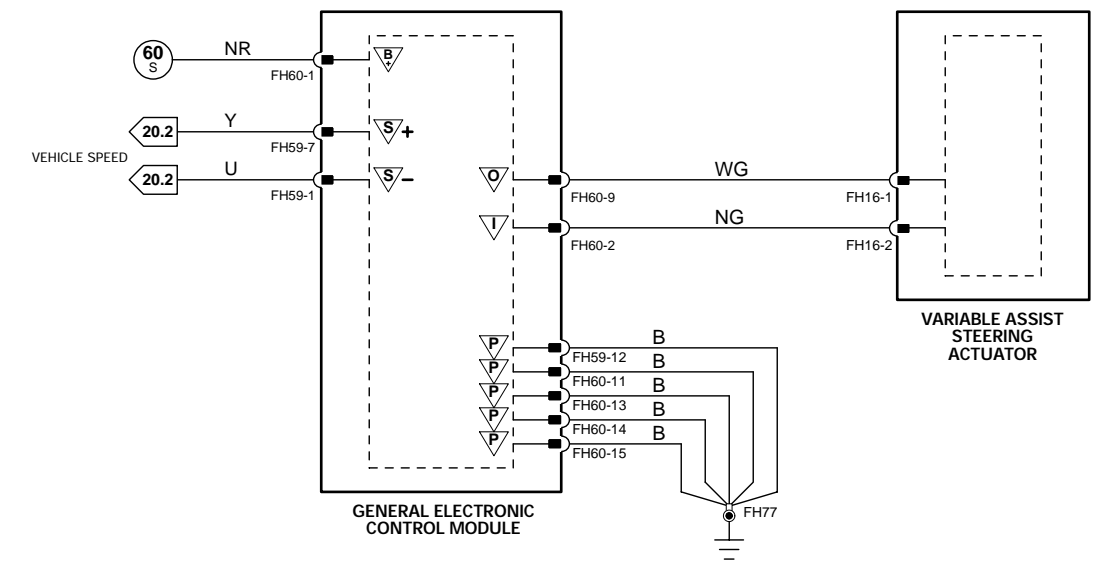

VARIABLE ASSIST POWER STEERING

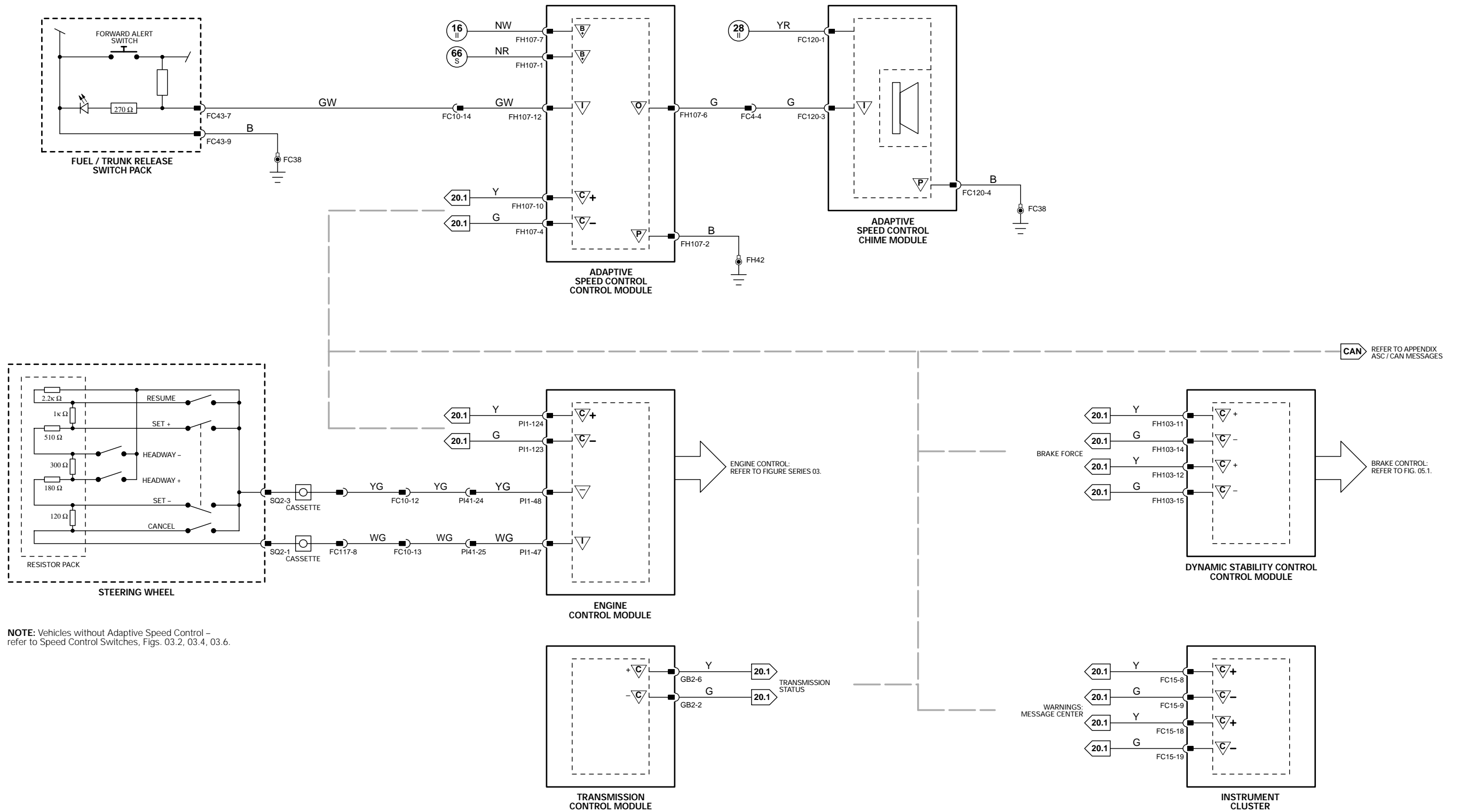

NOTE: Vehicles without Adaptive Speed Control - refer to Speed Control Switches, Figs. 03.2, 03.4, 03.6.

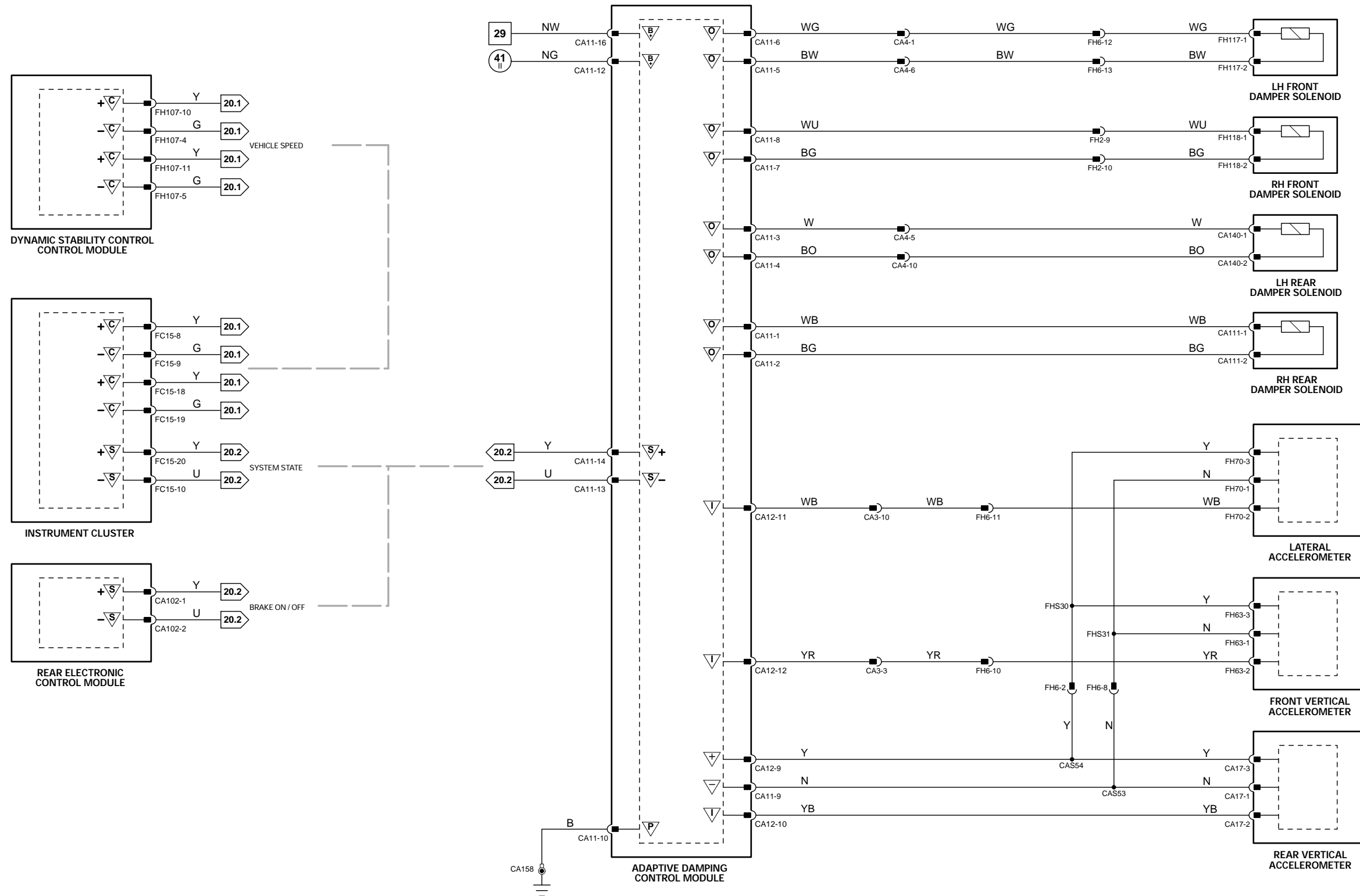

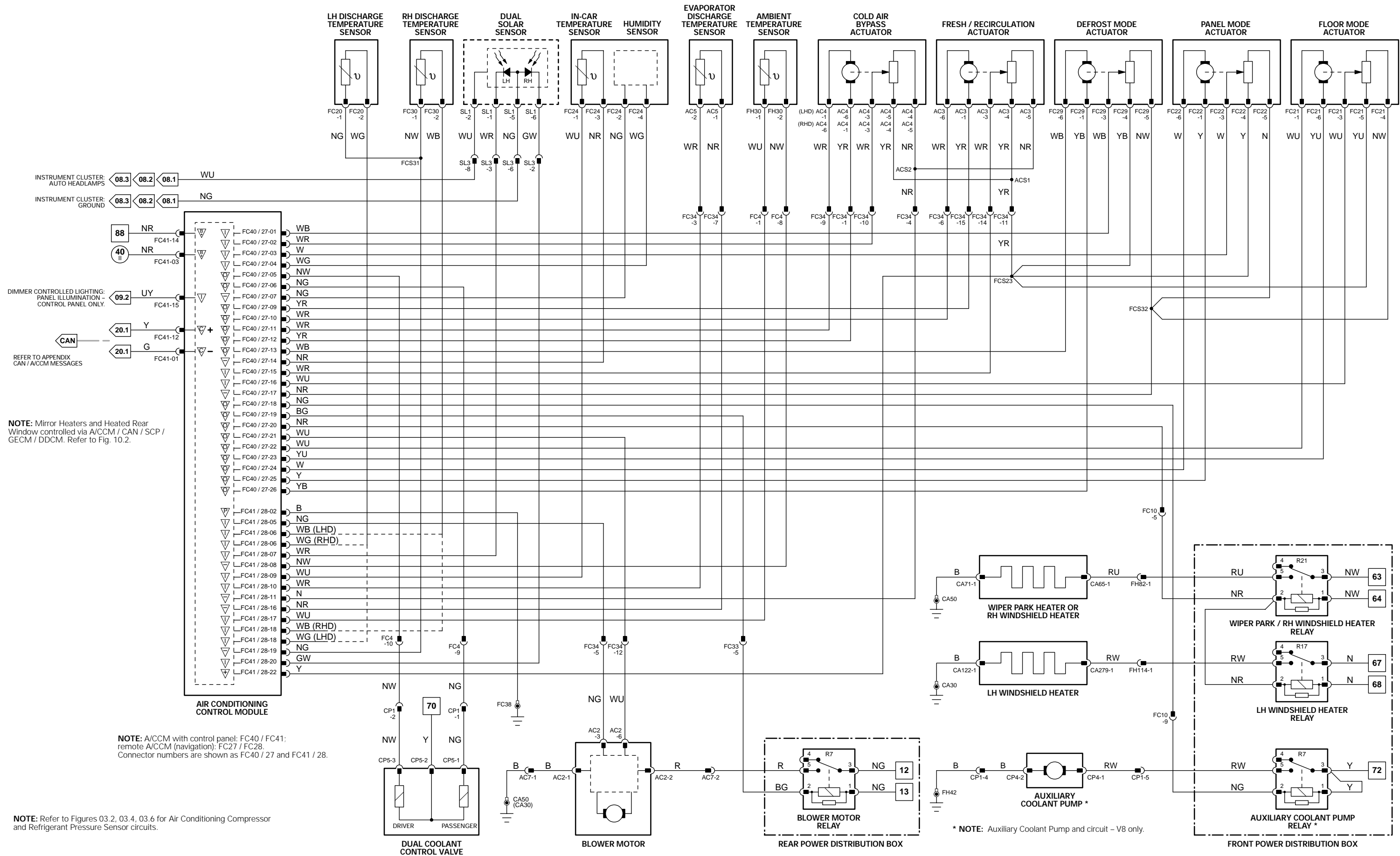

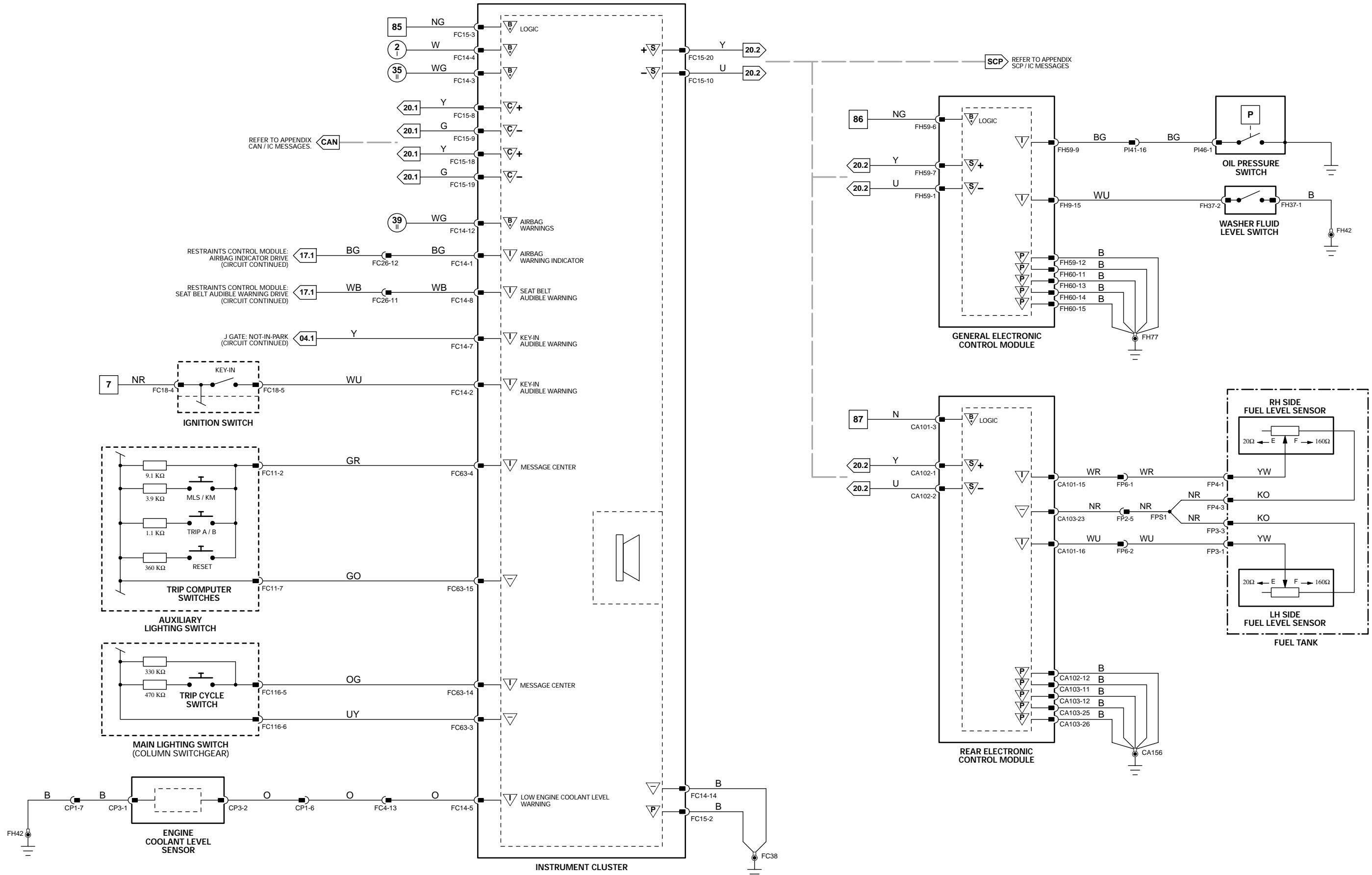

1 → 3	4 → 76	77 → 92	1 → 14	15 → 45	46 → 80	81 → 118	Input	B Battery Voltage	+/− Sensor/Signal Supply V	∇ CAN	∇ D2B Network
Fig. 01.1	Fig. 01.2	Fig. 01.3	Fig. 01.4	Fig. 01.5	Fig. 01.6	Fig. 01.7	Output	P Power Ground	∇ Sensor/Signal Ground	S SCP	∇ Serial and Encoded Data

VARIANT: All Vehicles
 VIN RANGE: All
 DATE OF ISSUE: March 2002 (PROVISIONAL)

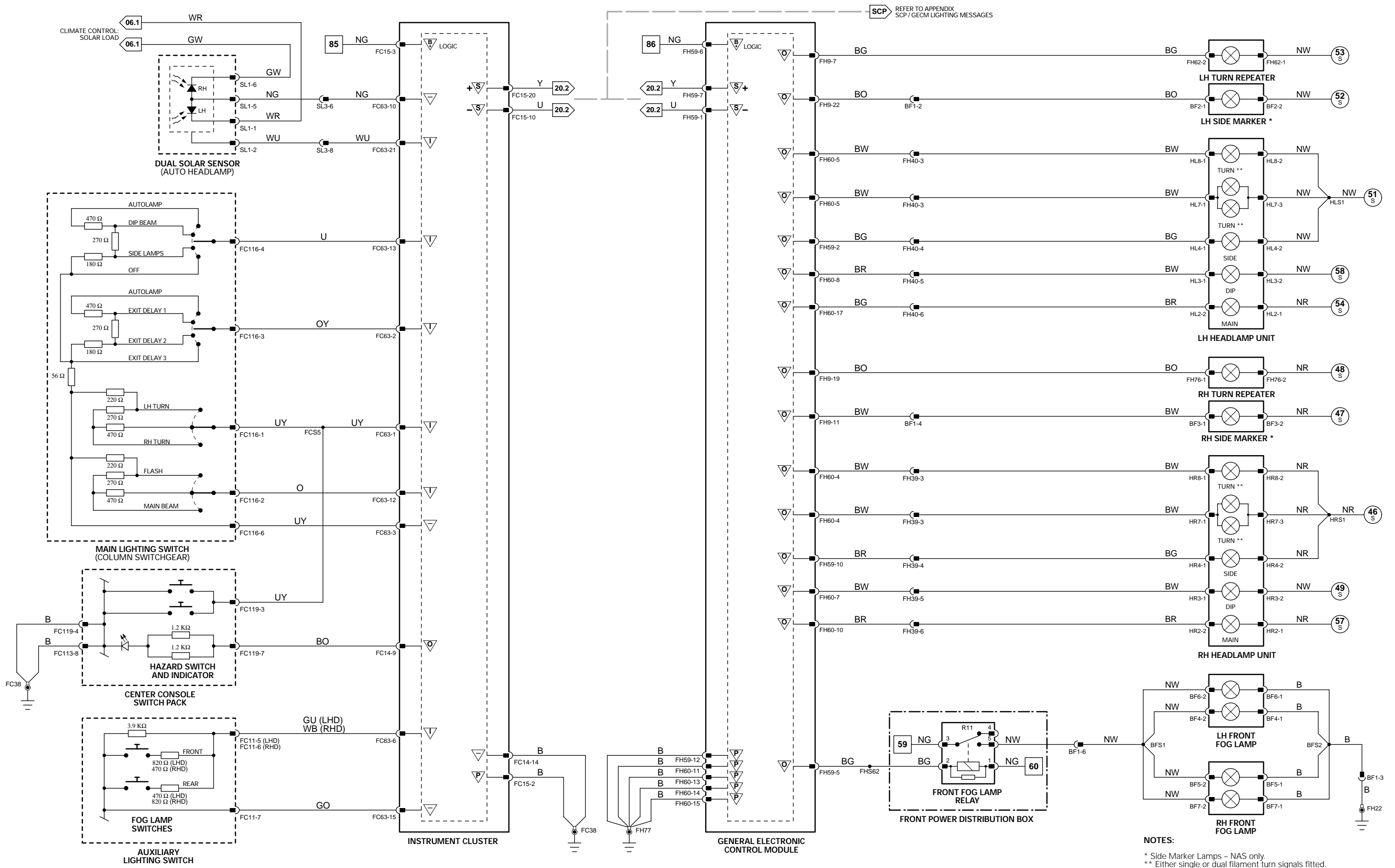

NOTES:
 * Side Marker Lamps - NAS only.
 ** Either single or dual filament turn signals fitted.

1 → 3	4 → 76	77 → 92	1 → 14	15 → 45	46 → 80	81 → 118	Input	B Battery Voltage	∇ Sensor/Signal Supply V	C CAN	D2B Network
Fig. 01.1	Fig. 01.2	Fig. 01.3	Fig. 01.4	Fig. 01.5	Fig. 01.6	Fig. 01.7	Output	P Power Ground	∇ Sensor/Signal Ground	S SCP	D Serial and Encoded Data

VARIANT: Non HID Headlamp Vehicles
 VIN RANGE: All
 DATE OF ISSUE: March 2002 (PROVISIONAL)

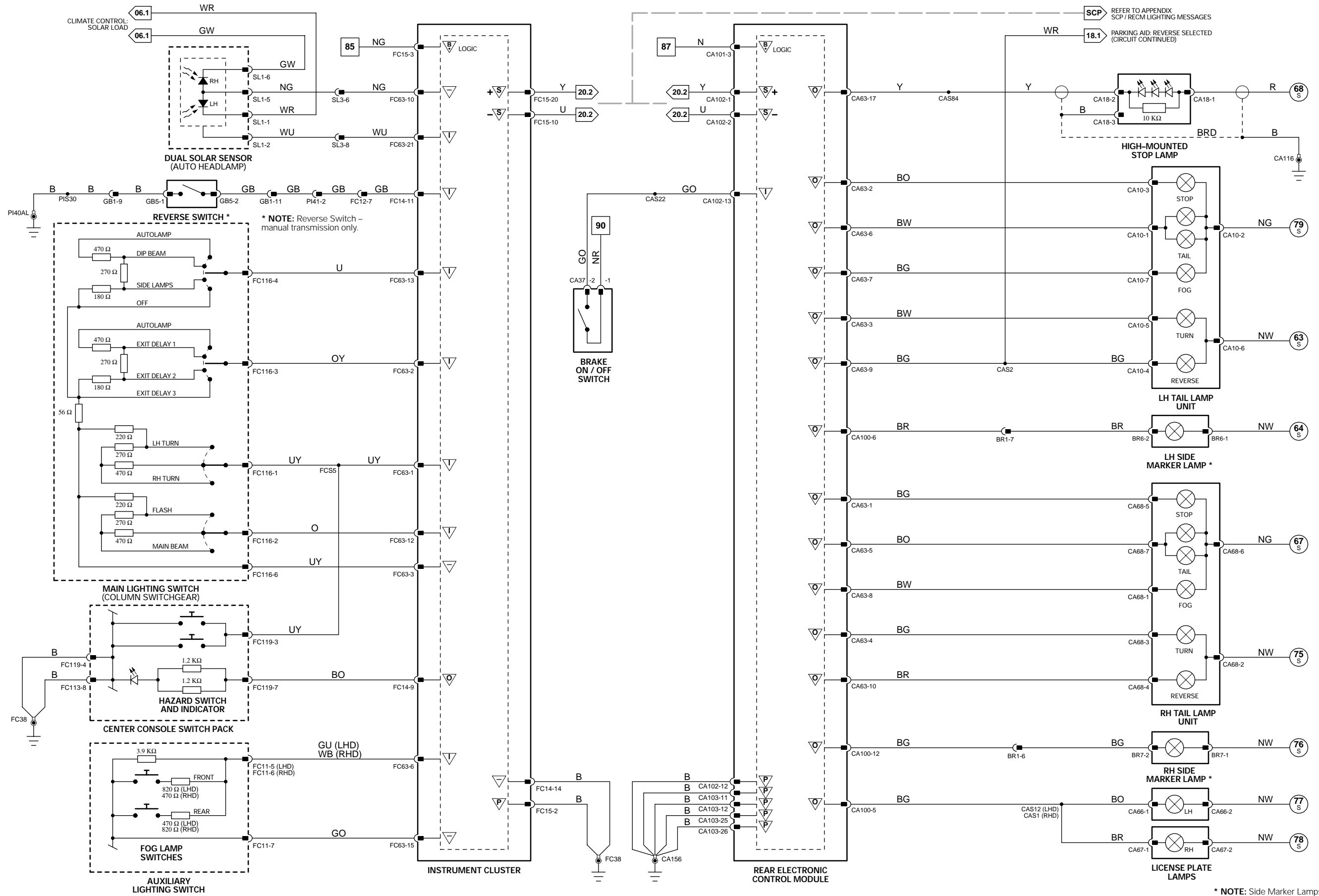

* NOTE: Side Marker Lamps - NAS only.

1 → 3 Fig. 01.1	4 → 76 Fig. 01.2	77 → 92 Fig. 01.3	1 → 14 Fig. 01.4	15 → 45 Fig. 01.5	46 → 80 Fig. 01.6	81 → 118 Fig. 01.7	▽ Input ▽ Output B Battery Voltage P Power Ground S Sensor/Signal Supply V S Sensor/Signal Ground C CAN D D2B Network SCP S Serial and Encoded Data	VARIANT: All Vehicles VIN RANGE: All DATE OF ISSUE: March 2002 (PROVISIONAL)
--------------------	---------------------	----------------------	---------------------	----------------------	----------------------	-----------------------	--	--

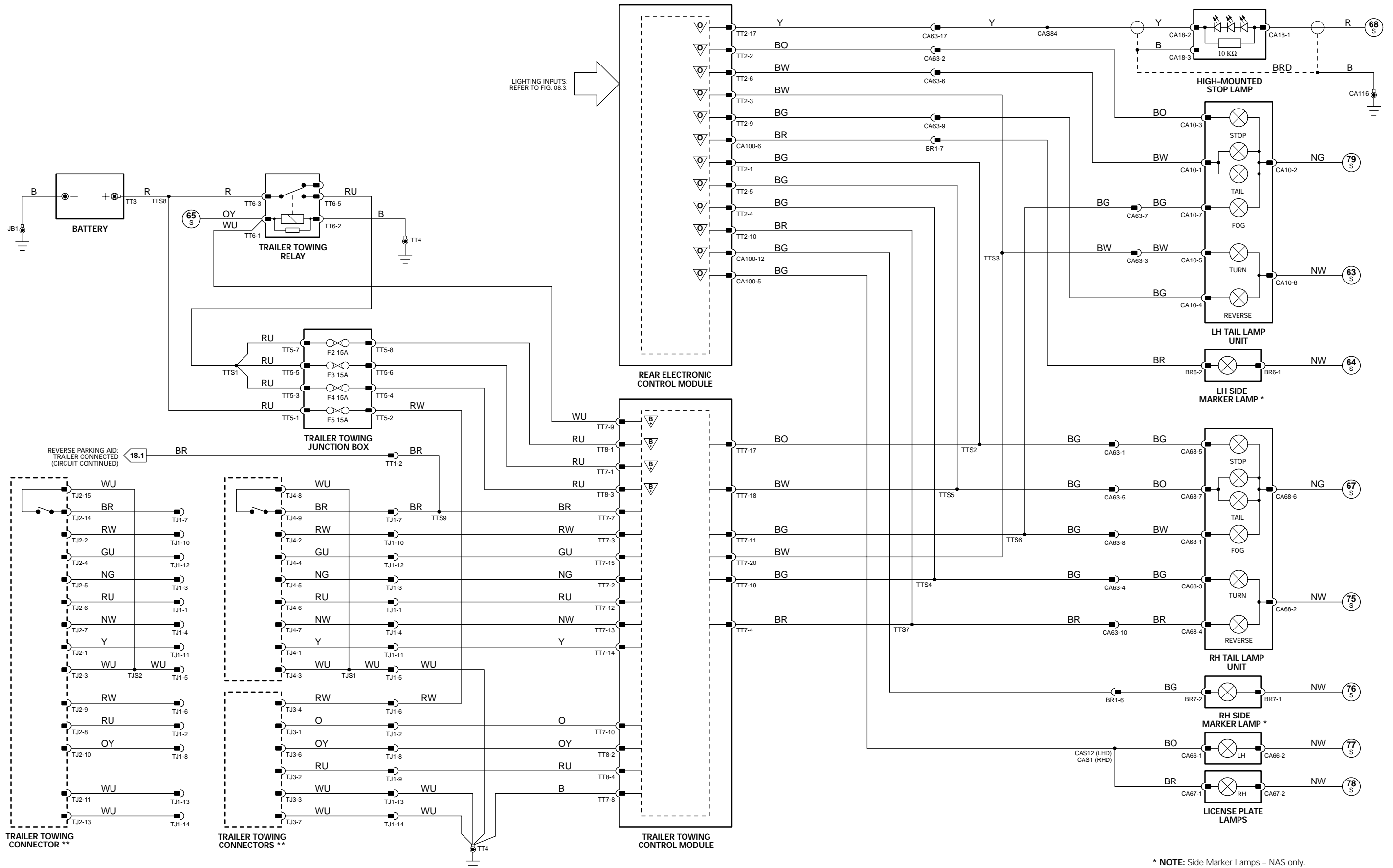

** NOTE: Either single connector or two connectors fitted.

* NOTE: Side Marker Lamps - NAS only.

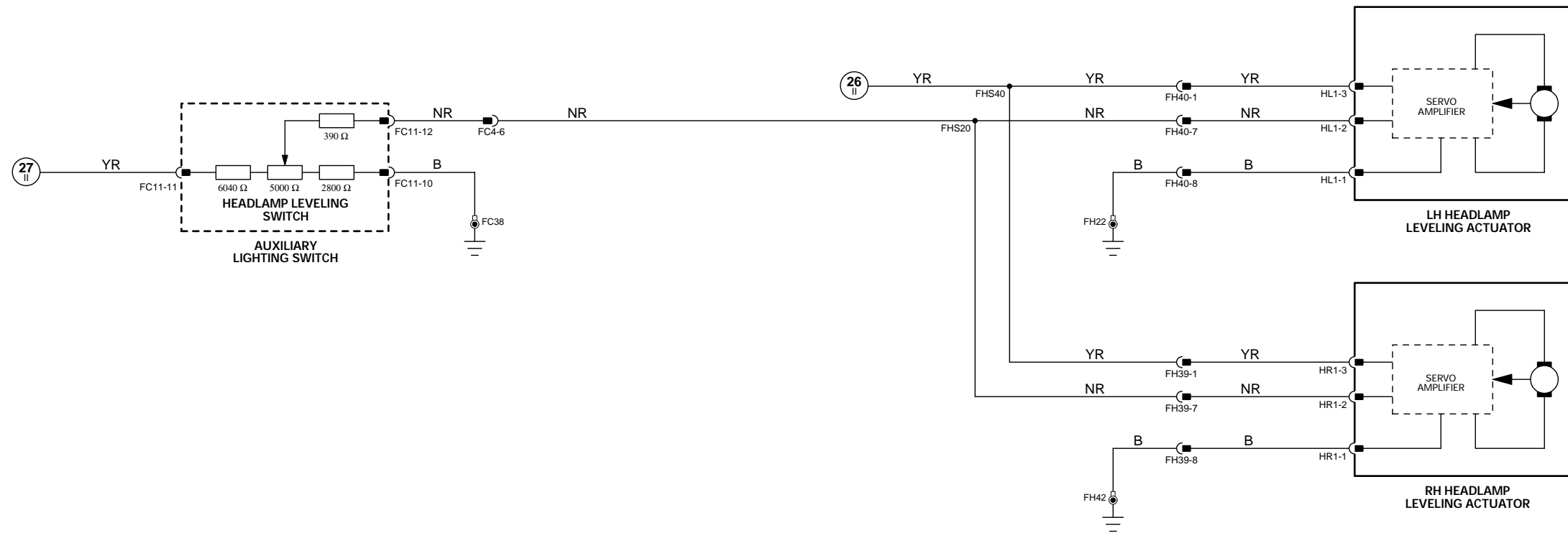

DRIVER-CONTROLLED HEADLAMP LEVELING

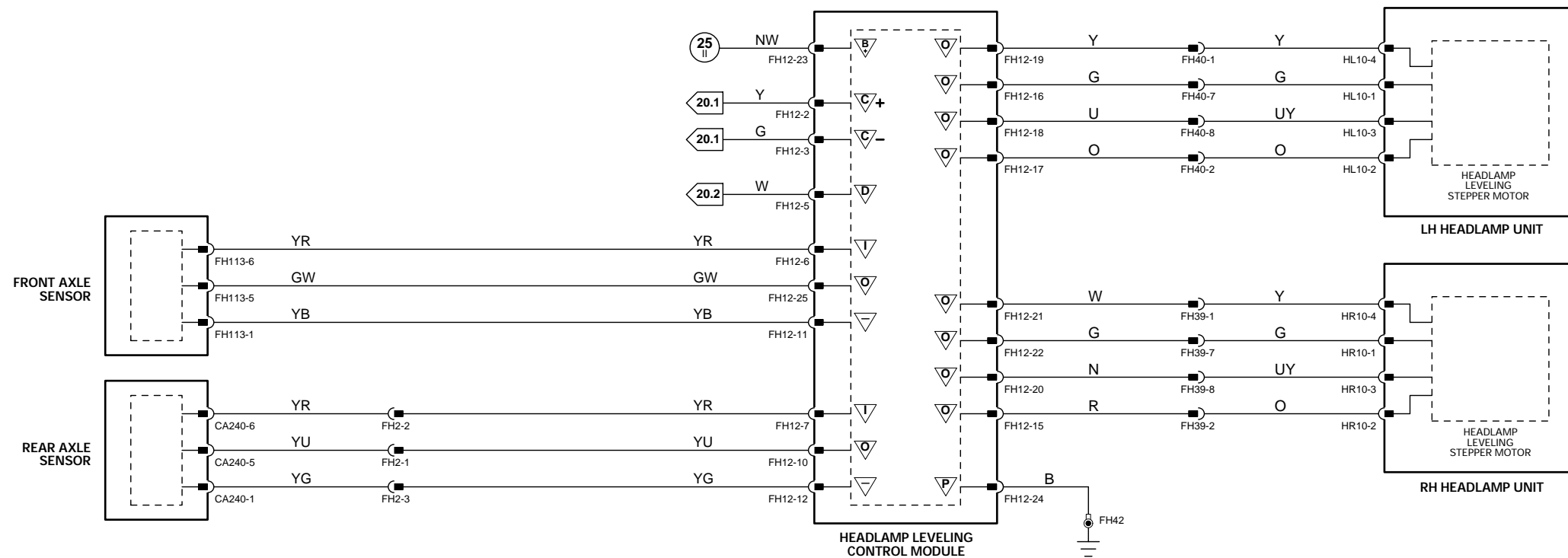

AUTOMATIC HEADLAMP LEVELING

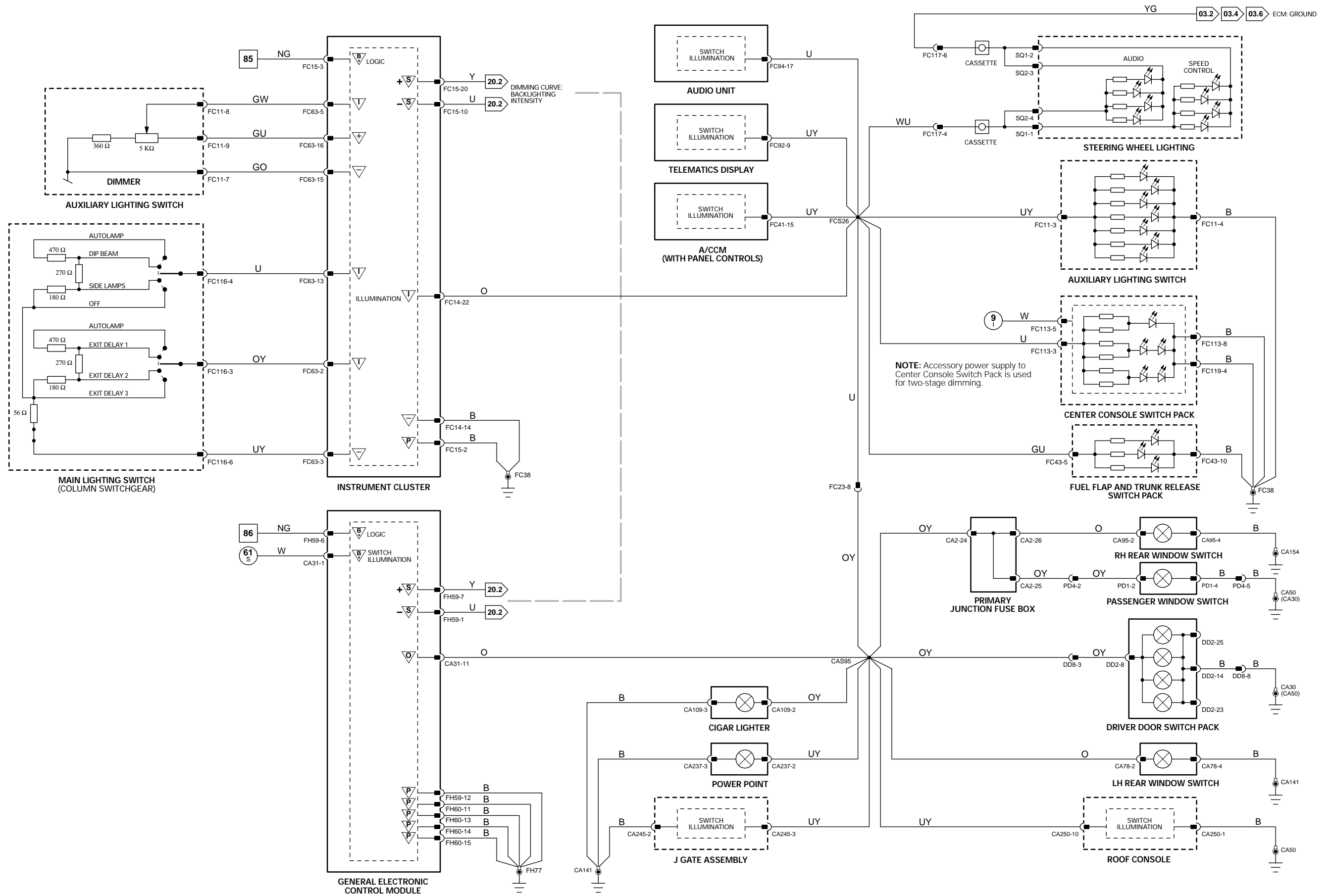

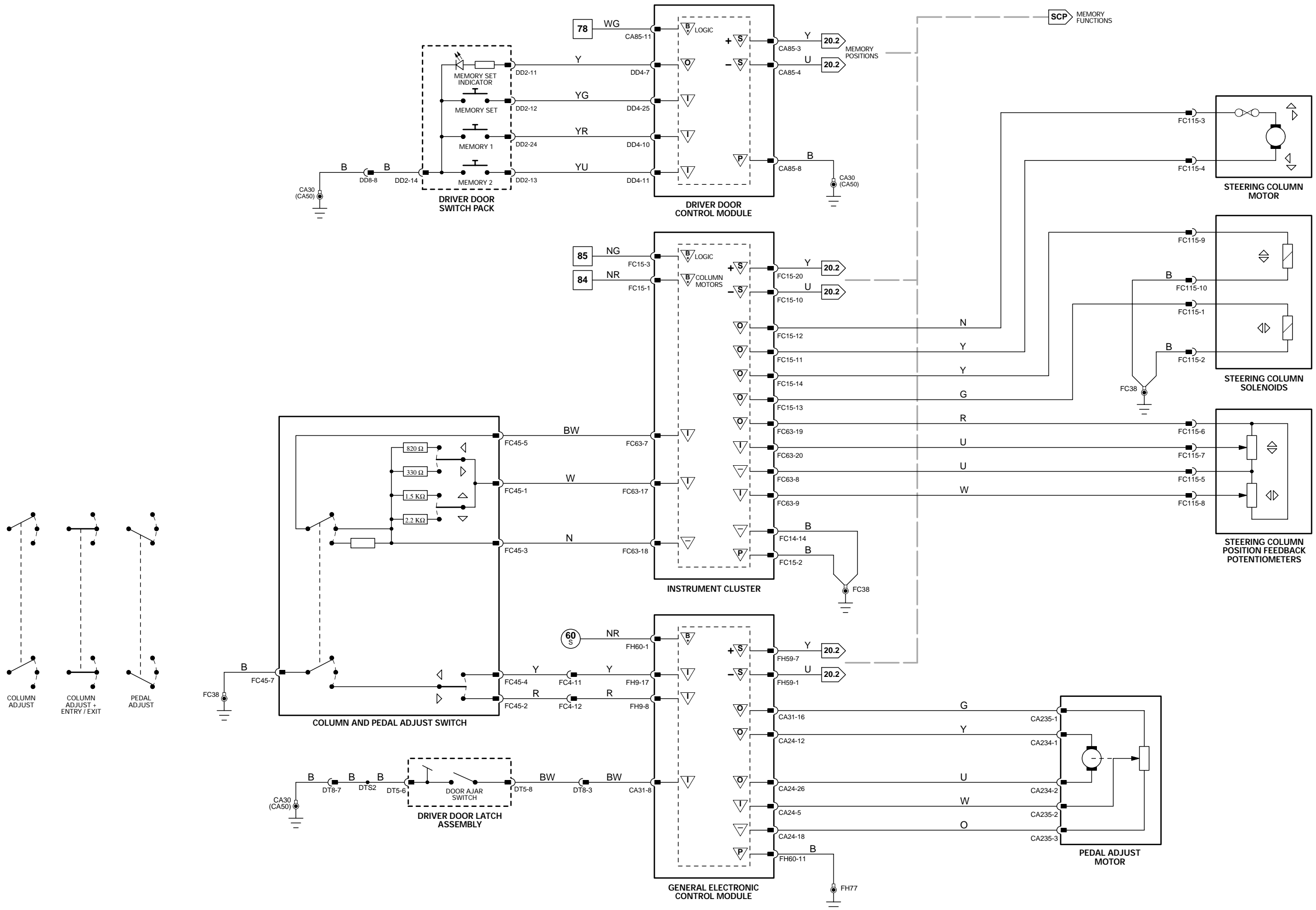

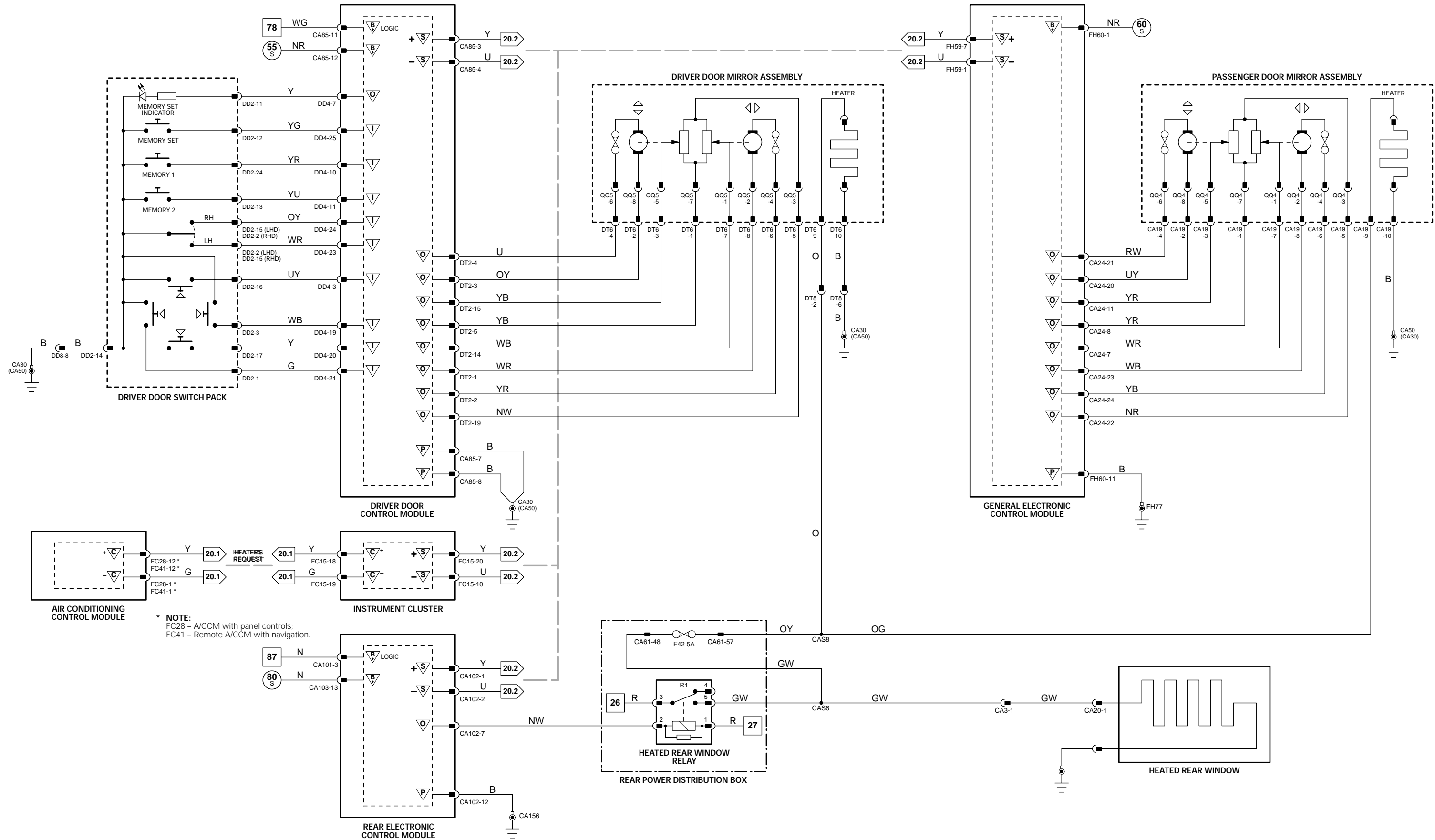

* NOTE:
 FC28 - A/CCM with panel controls;
 FC41 - Remote A/CCM with navigation.

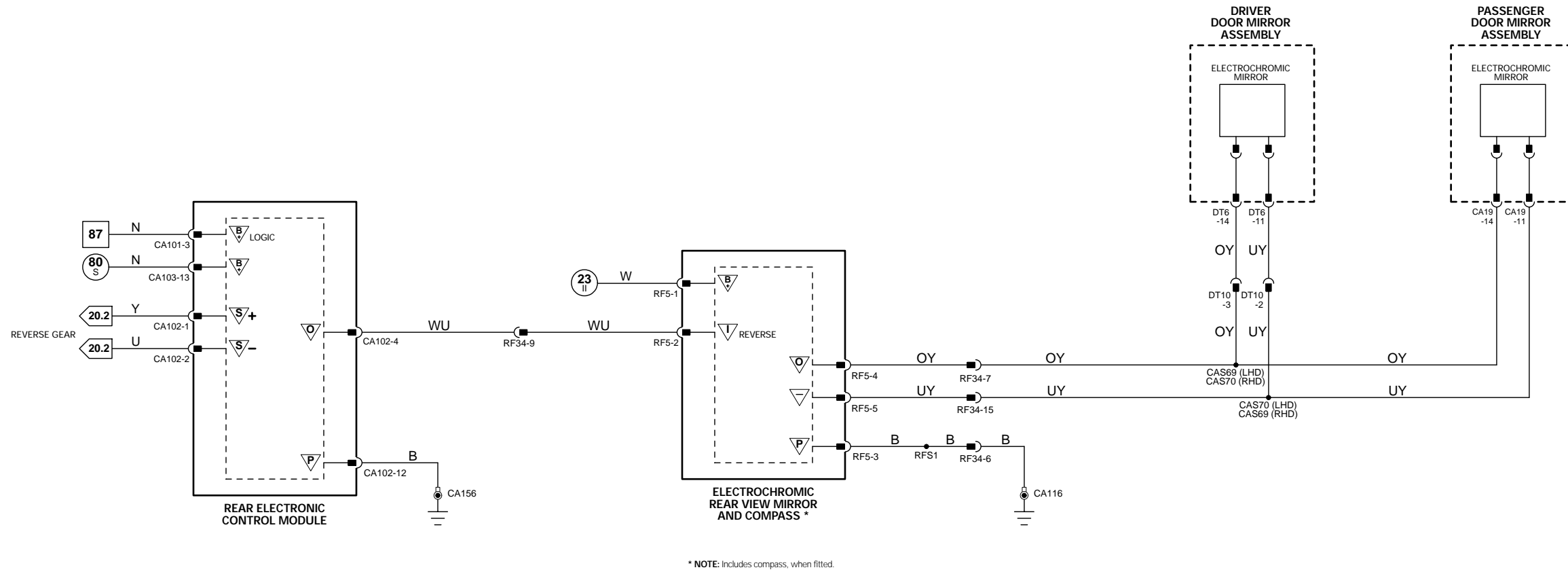

ELECTROCHROMIC REAR VIEW MIRRORS

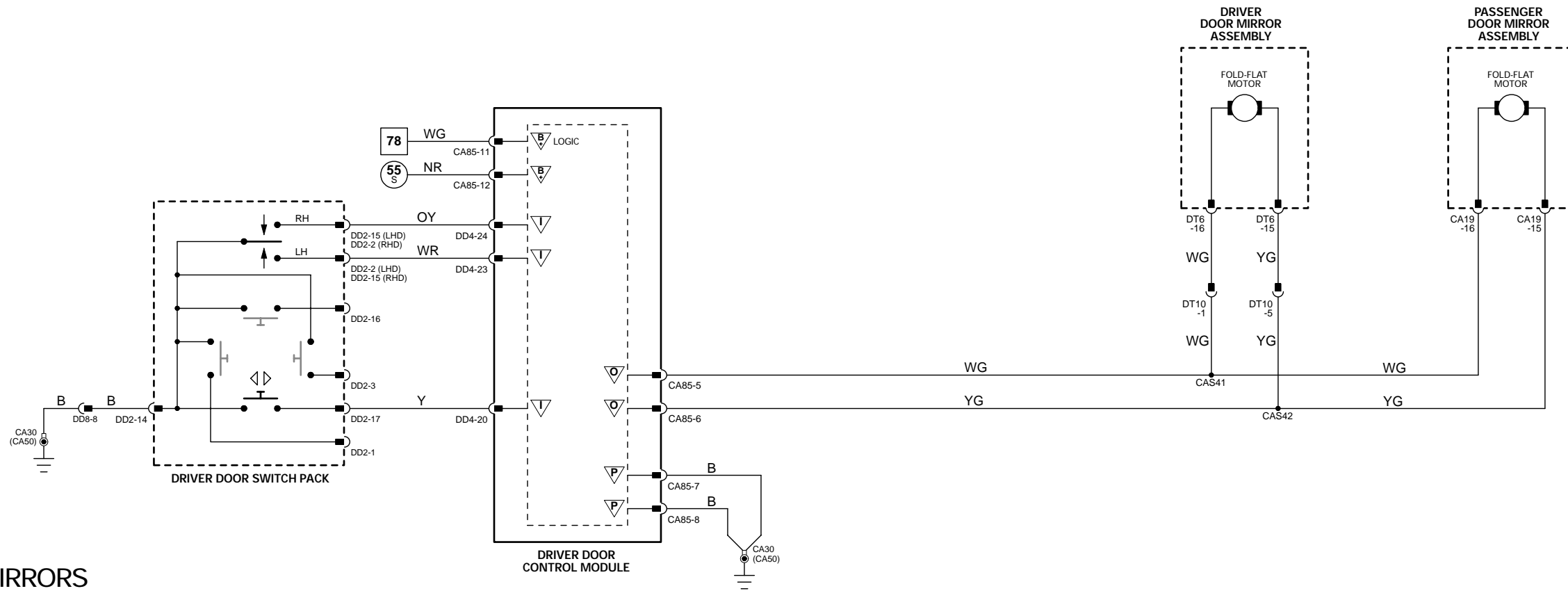

FOLD-BACK MIRRORS

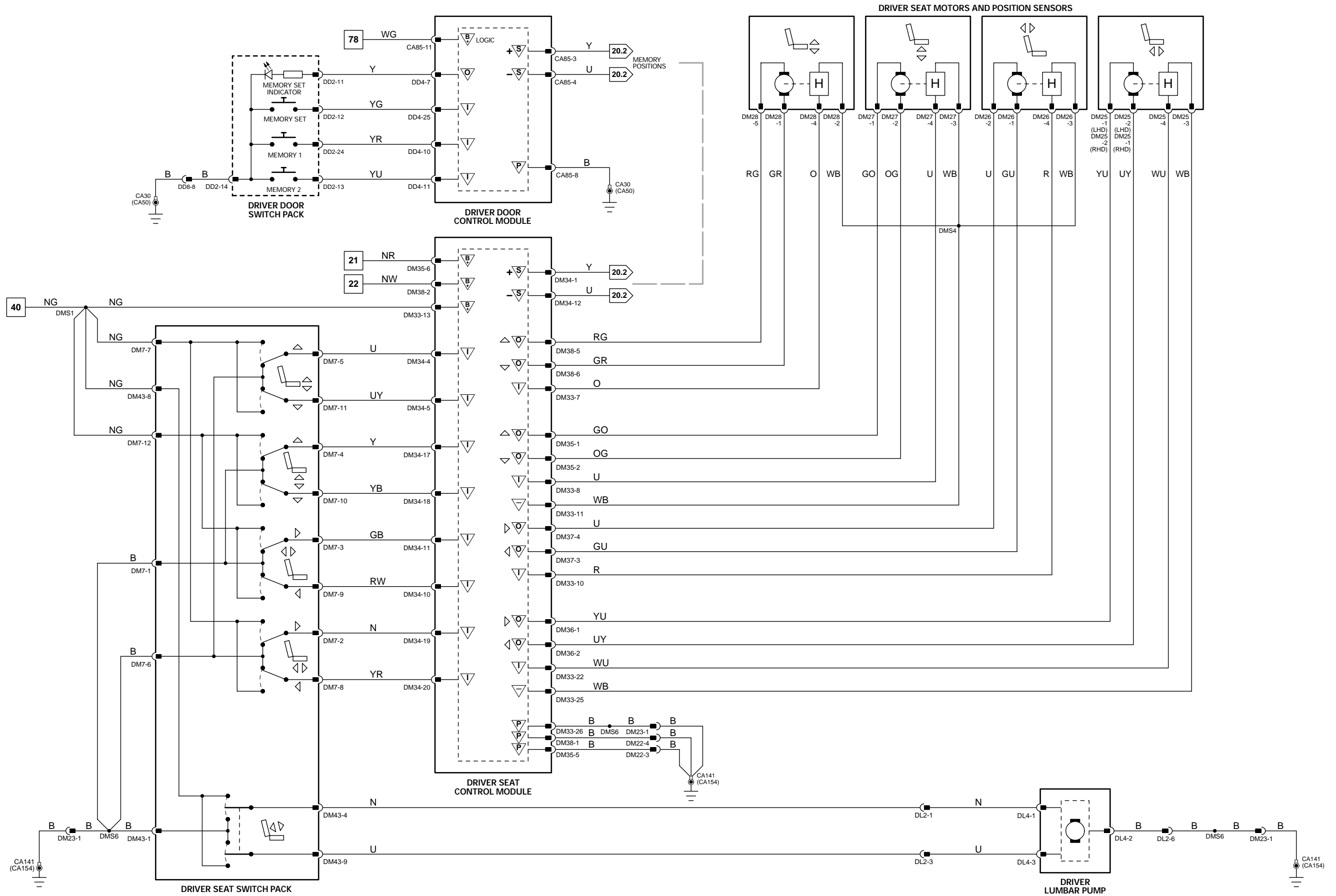

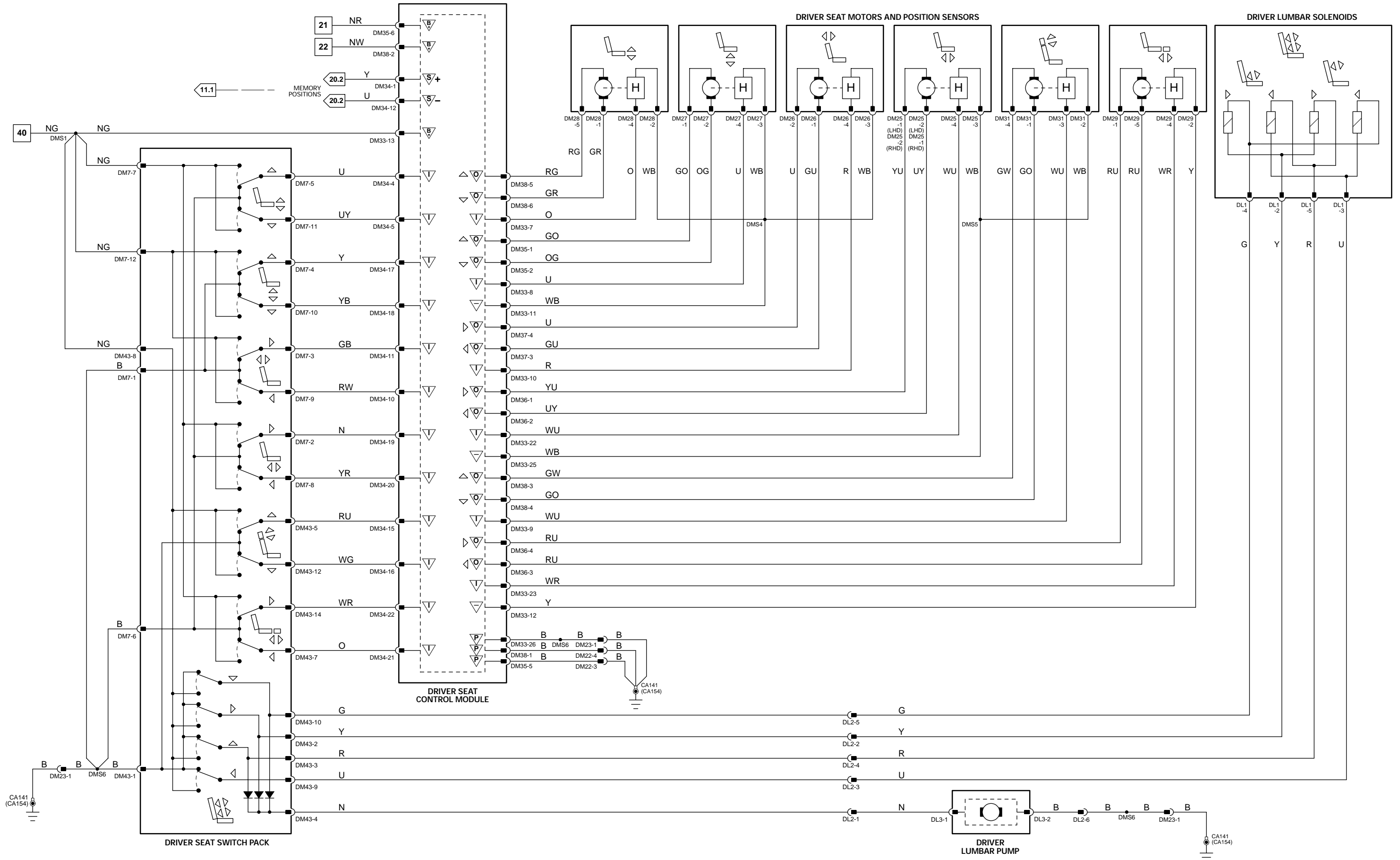

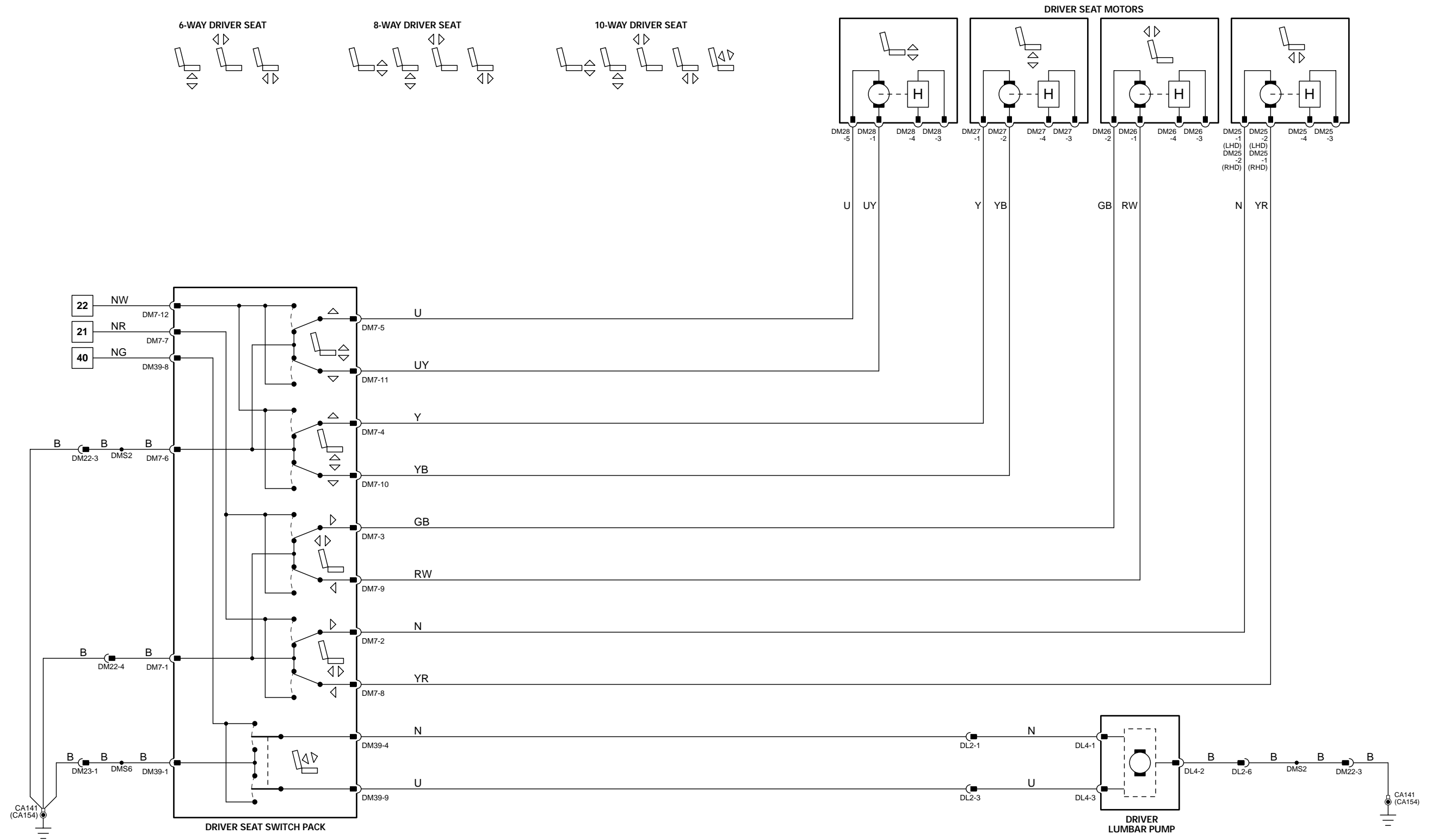

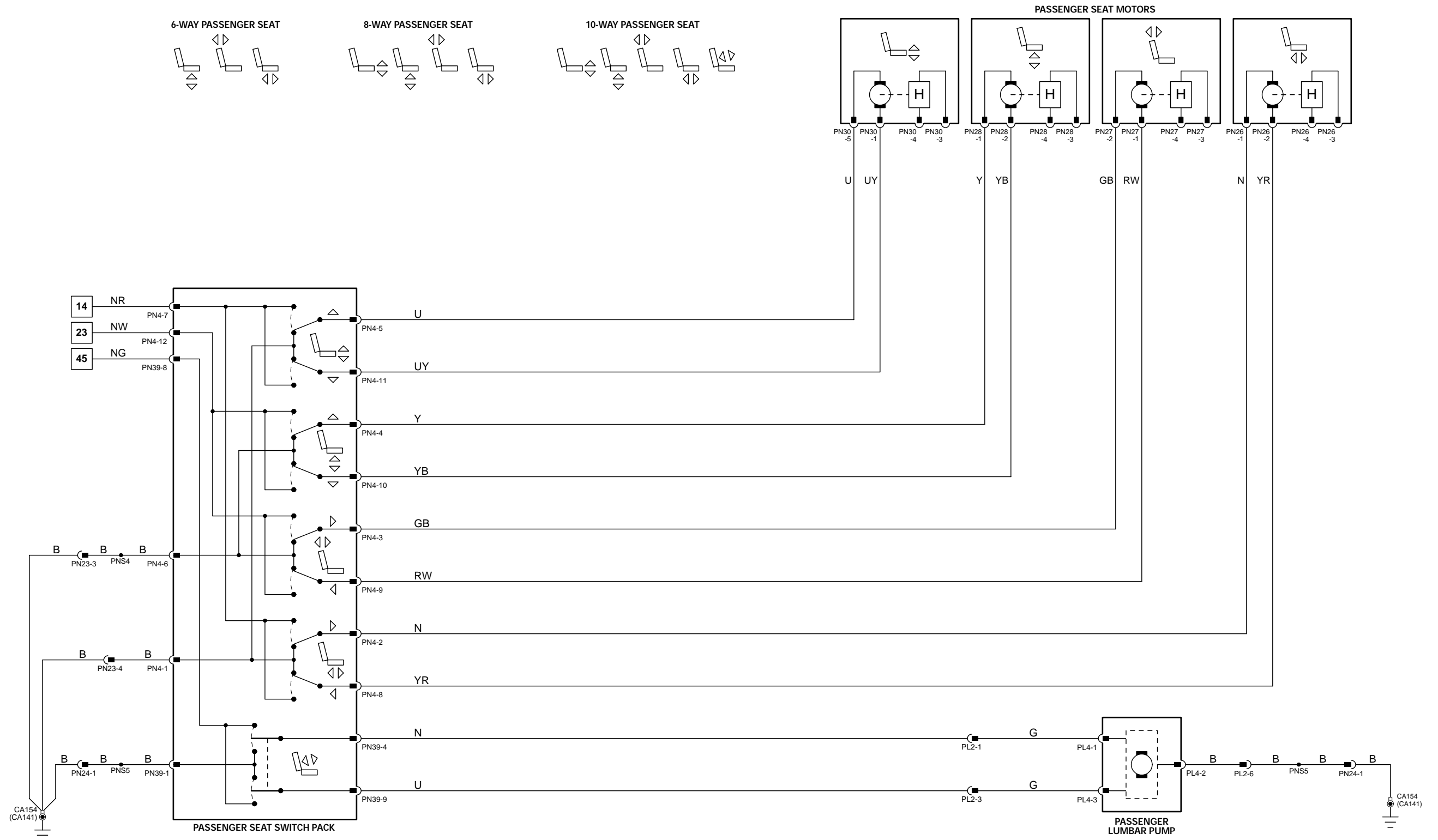

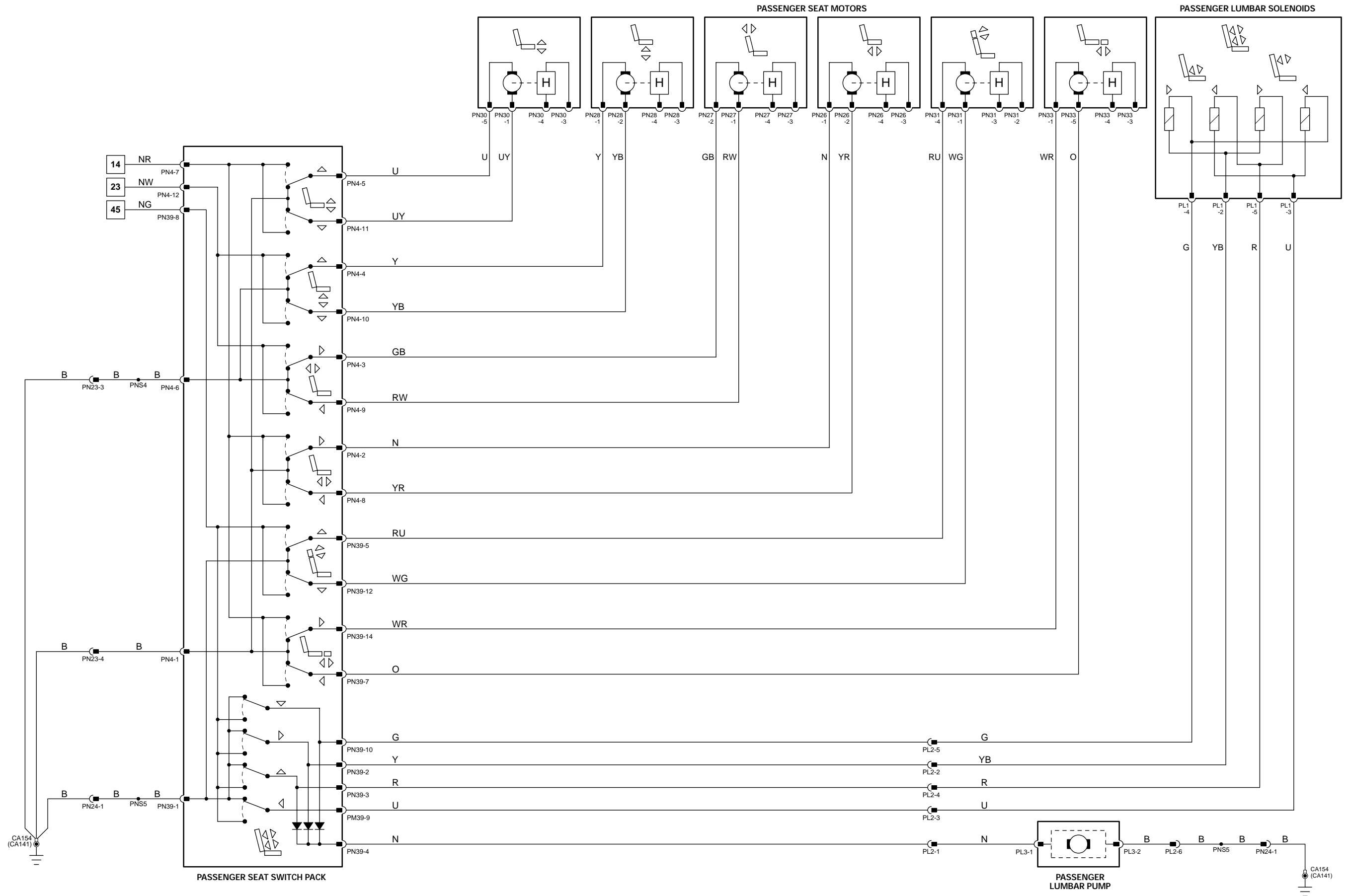

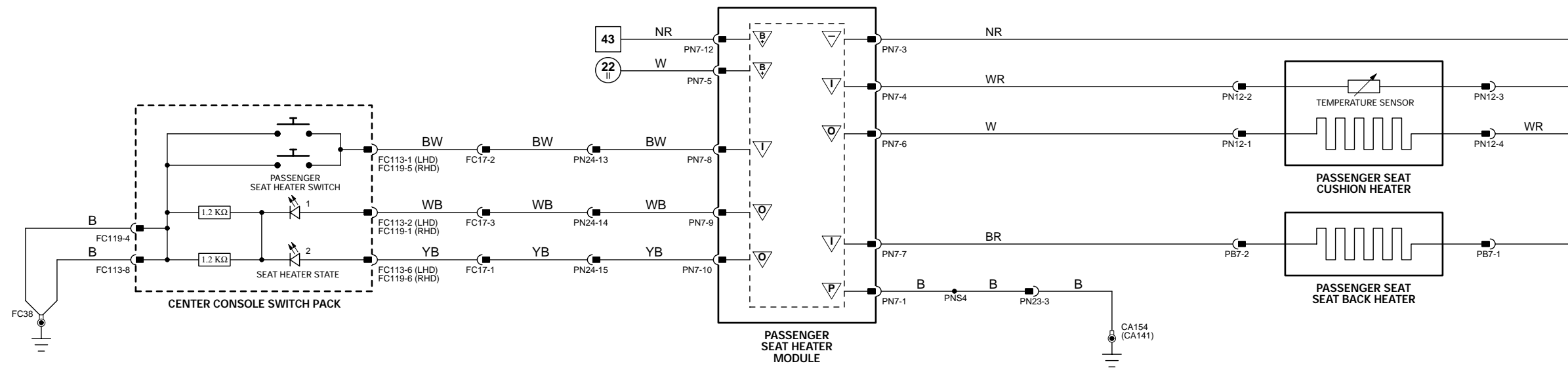
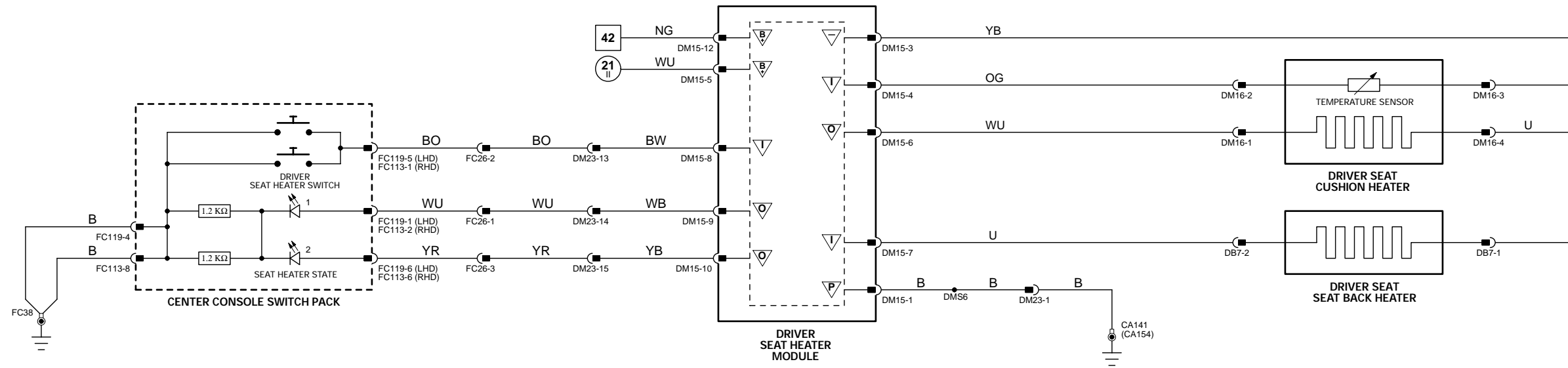

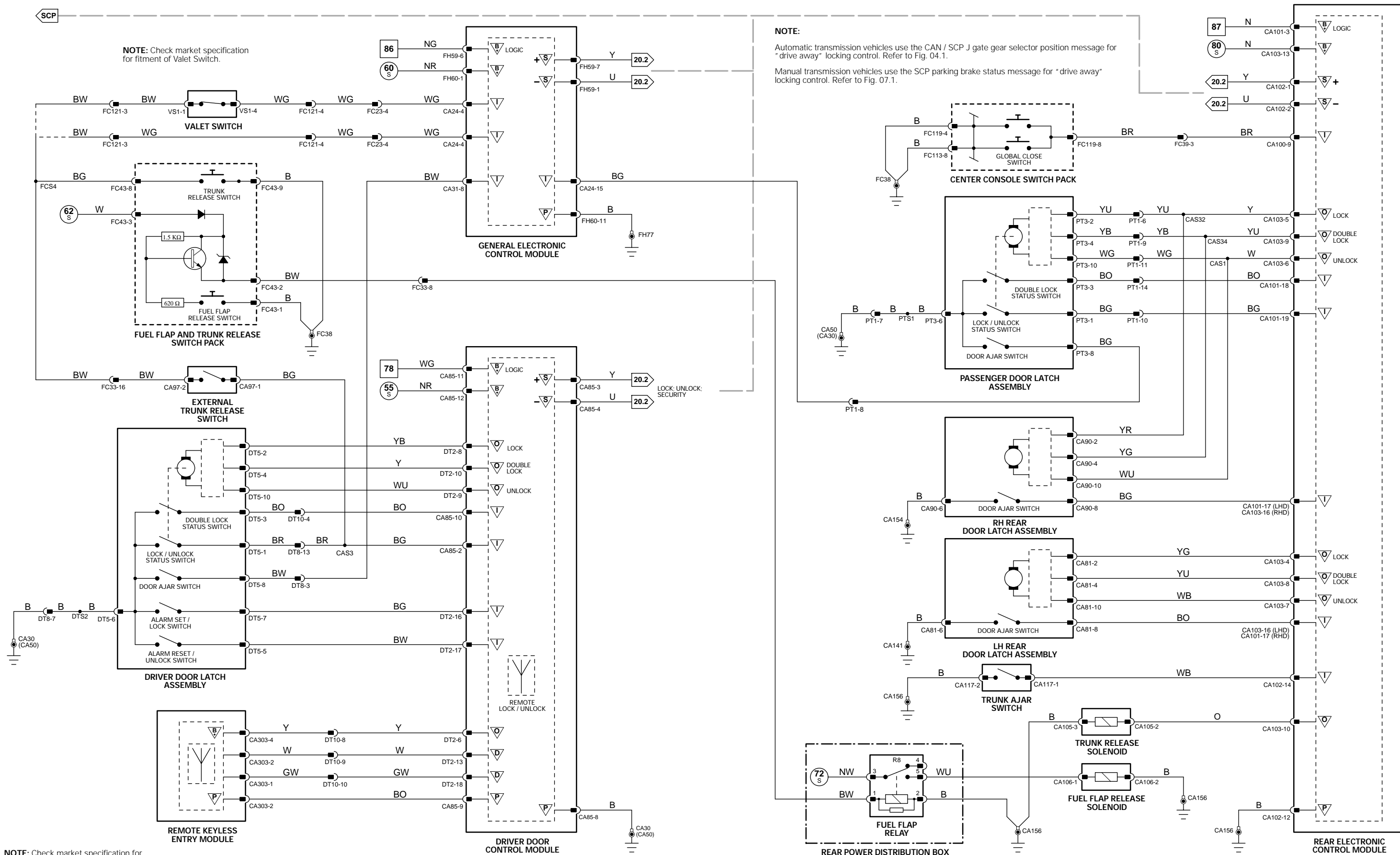

NOTE:
 Automatic transmission vehicles use the CAN / SCP J gate gear selector position message for "drive away" locking control. Refer to Fig. 04.1.
 Manual transmission vehicles use the SCP parking brake status message for "drive away" locking control. Refer to Fig. 07.1.

NOTE: Check market specification for fitment of Remote Keyless Entry.

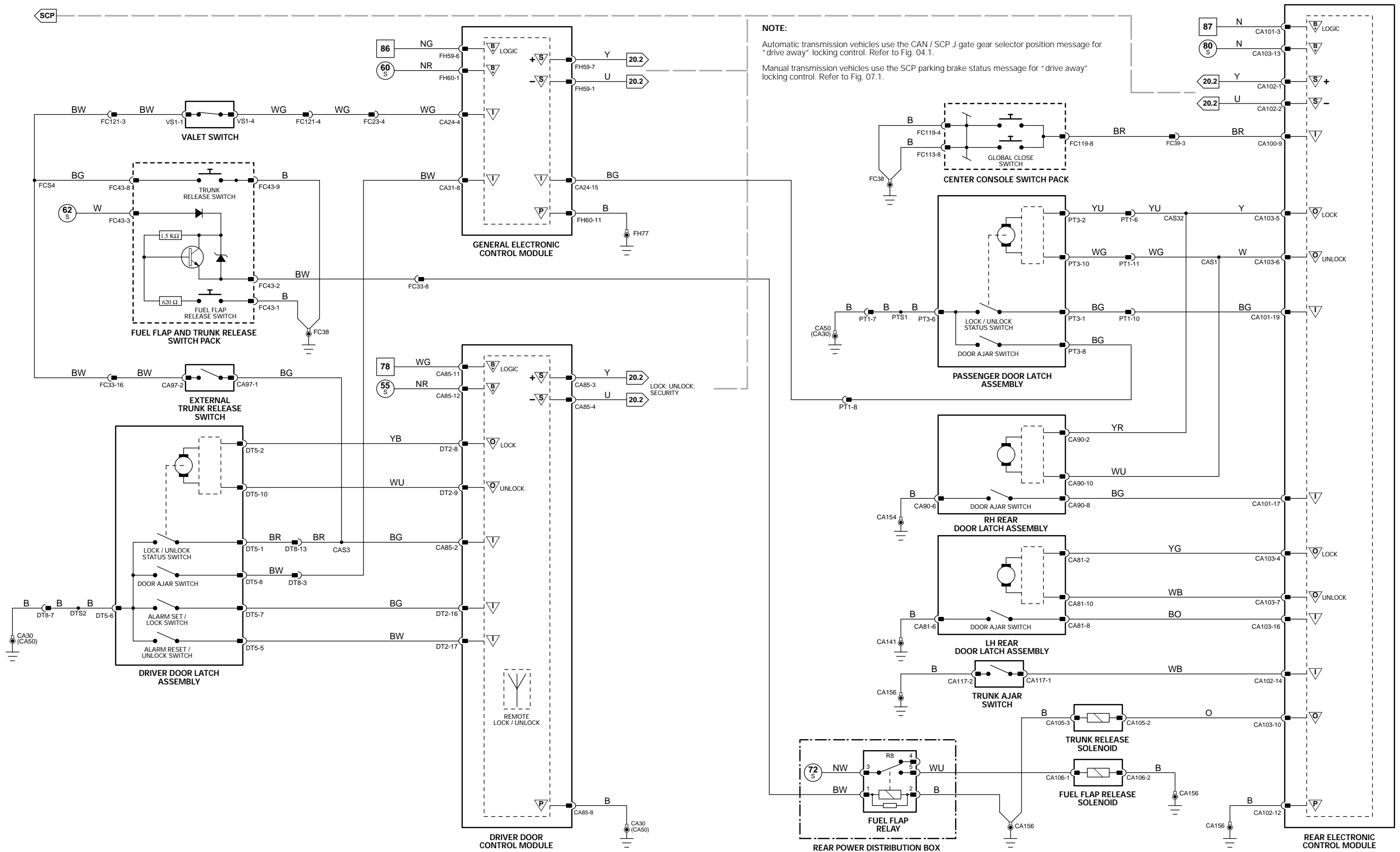

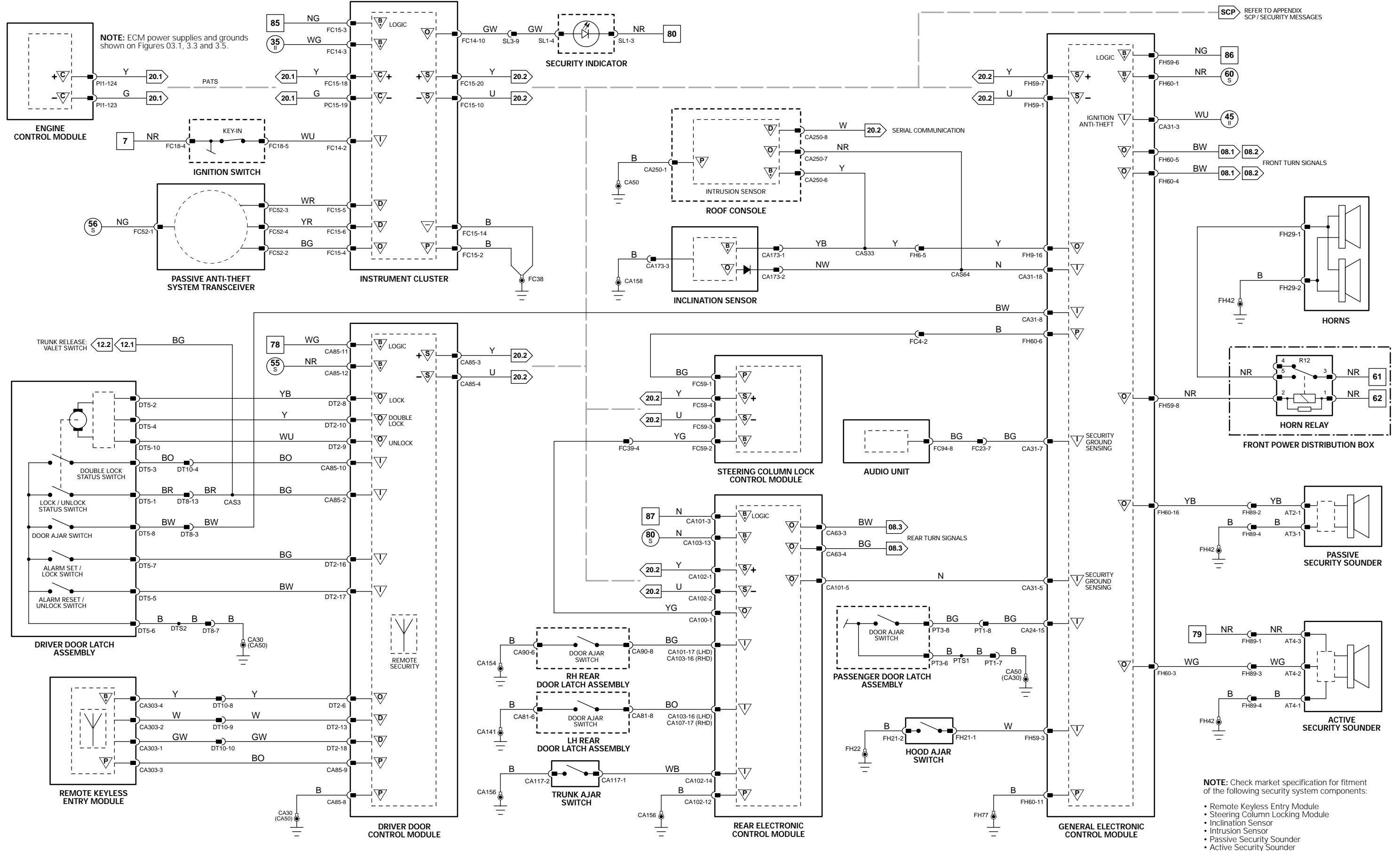

SCP REFER TO APPENDIX SCP / SECURITY MESSAGES

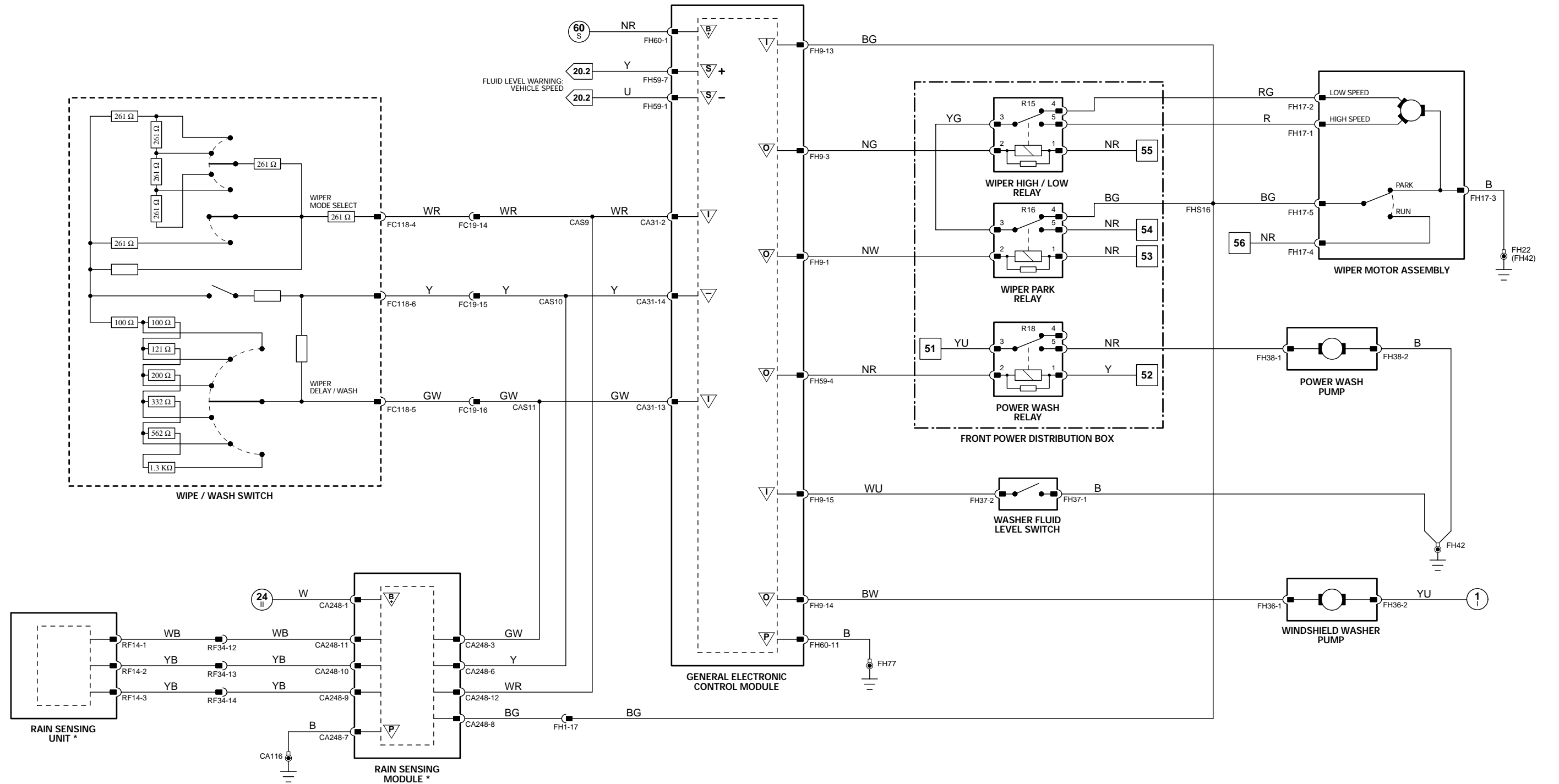

* NOTE: Rain sensing system – rain sensing vehicles only.

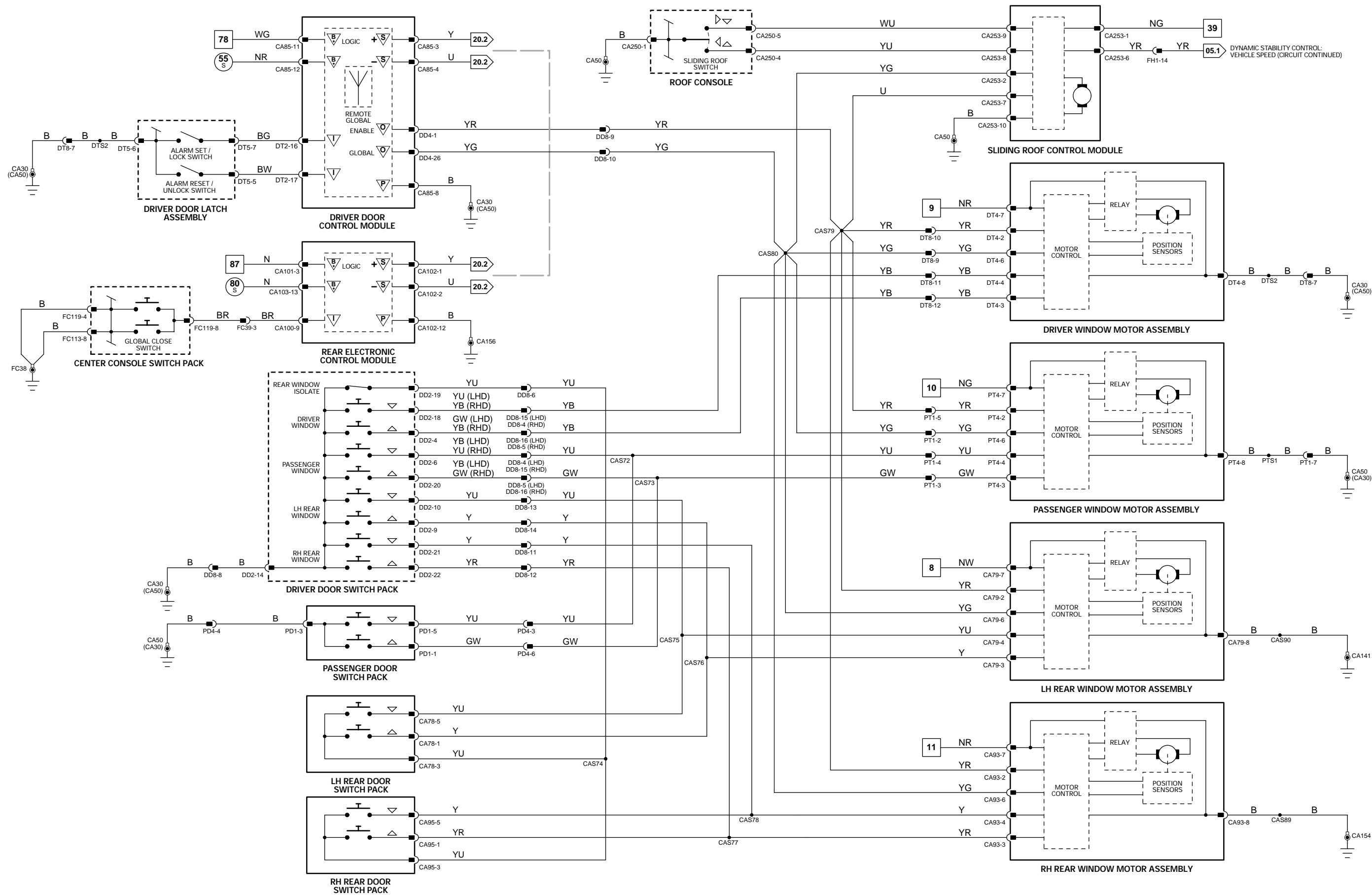

DYNAMIC STABILITY CONTROL: VEHICLE SPEED (CIRCUIT CONTINUED)

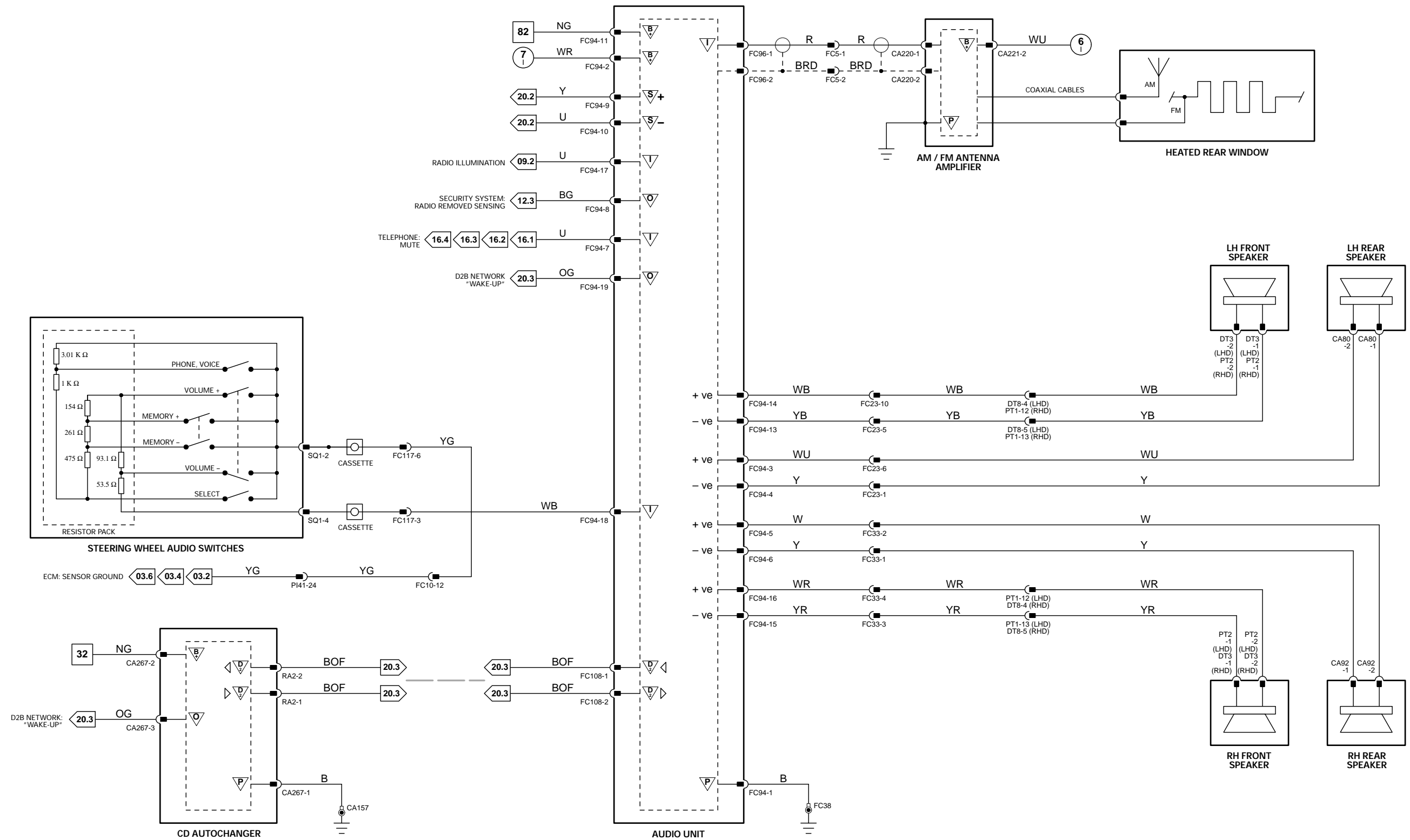

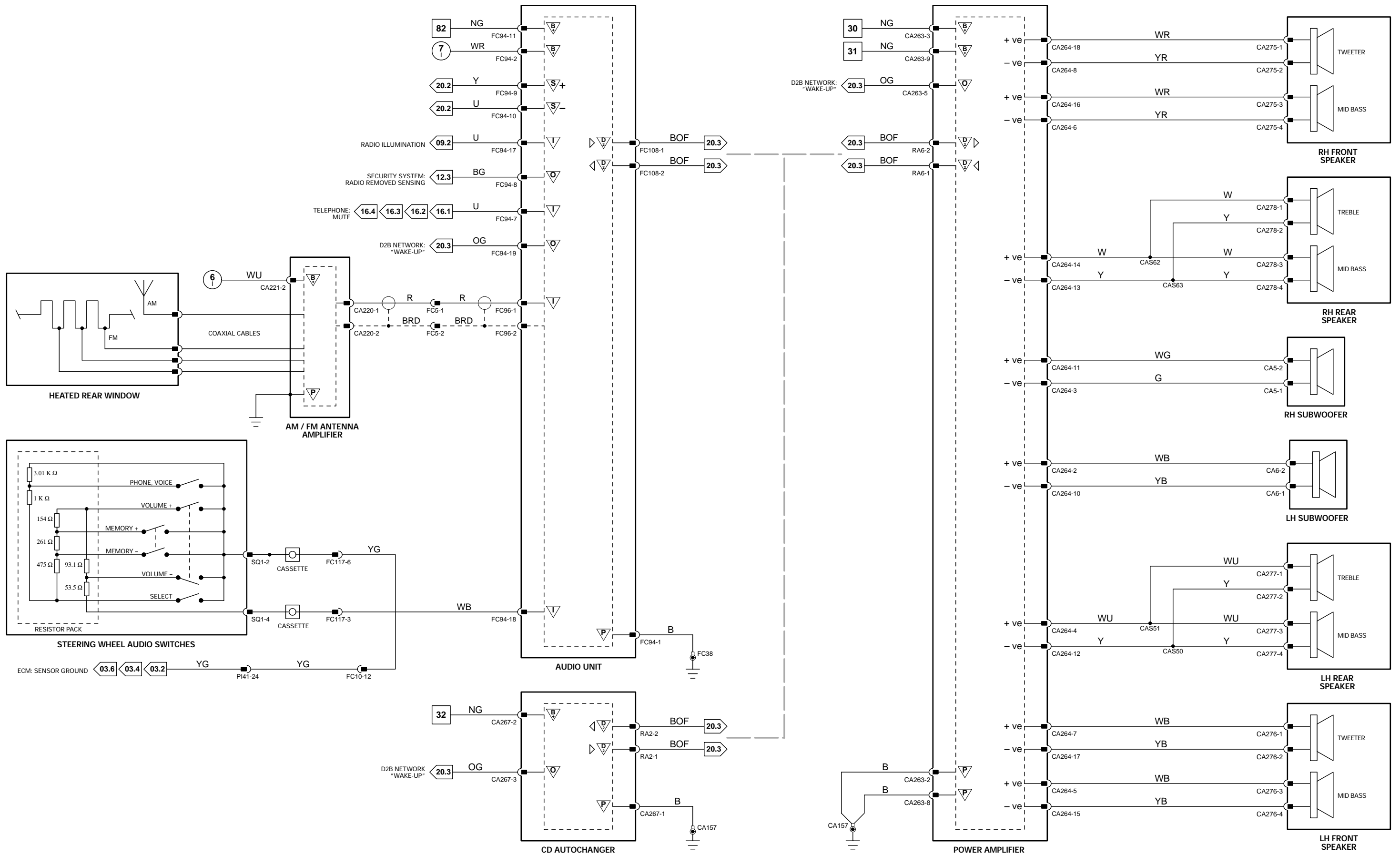

1 → 3 Fig. 01.1	4 → 76 Fig. 01.2	77 → 92 Fig. 01.3	1 → 14 Fig. 01.4	15 → 45 Fig. 01.5	46 → 80 Fig. 01.6	81 → 118 Fig. 01.7	Input	Battery Voltage	Sensor/Signal Supply V	CAN	D2B Network
							Output	Power Ground	Sensor/Signal Ground	SCP	Serial and Encoded Data

VARIANT: Premium ICE Vehicles
 VIN RANGE: All
 DATE OF ISSUE: March 2002 (PROVISIONAL)

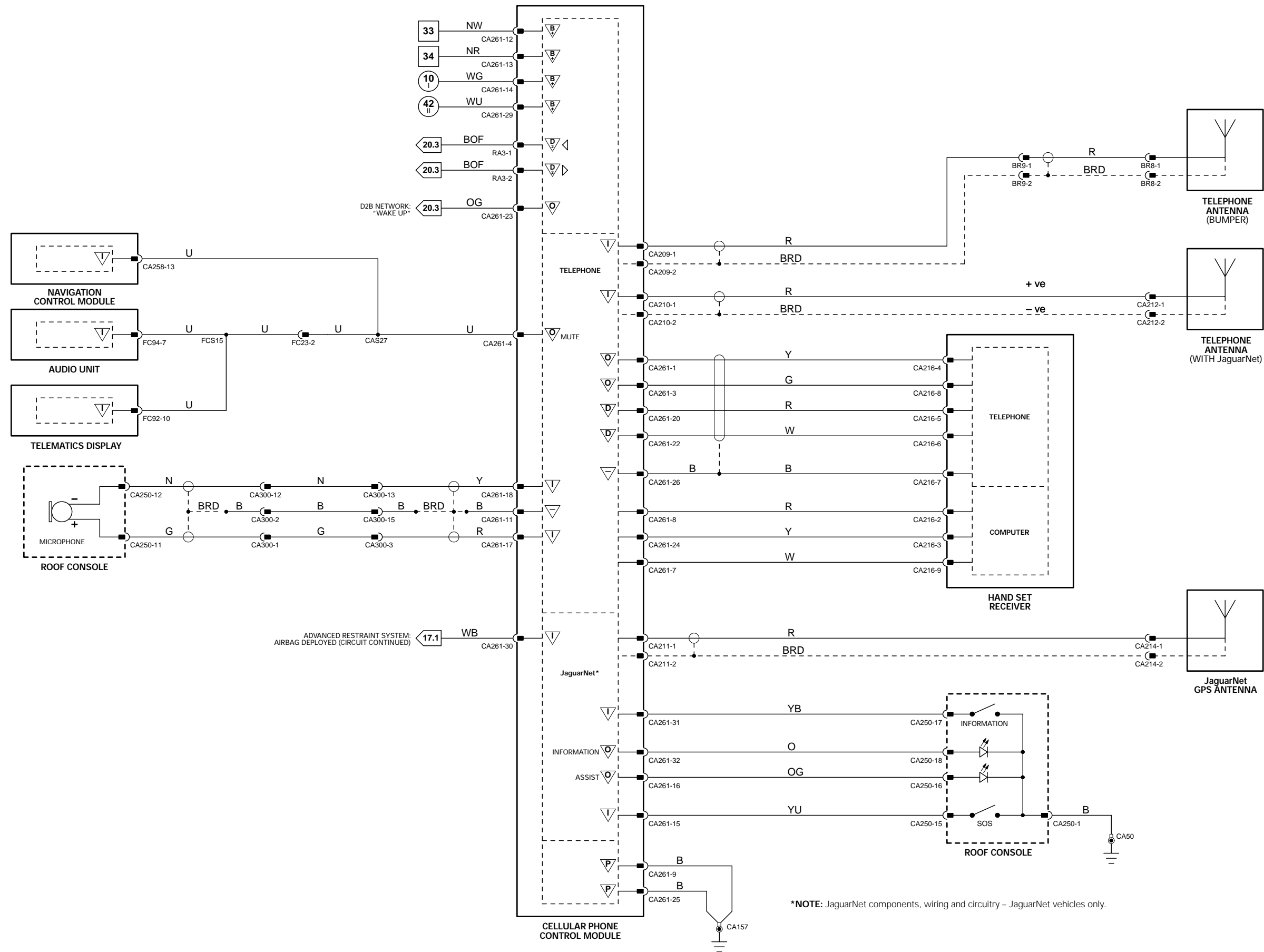

*NOTE: JaguarNet components, wiring and circuitry - JaguarNet vehicles only.

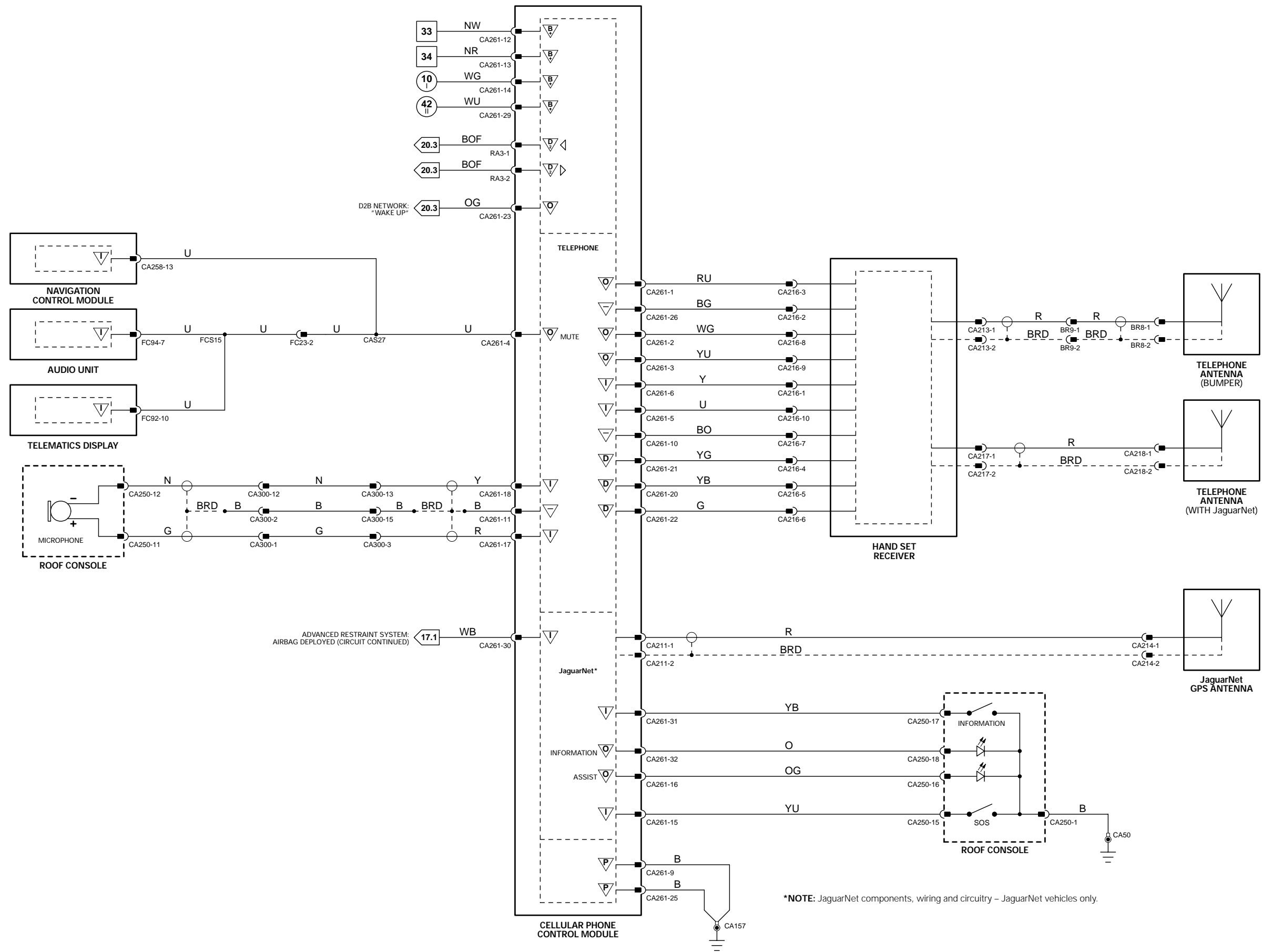

*NOTE: JaguarNet components, wiring and circuitry – JaguarNet vehicles only.

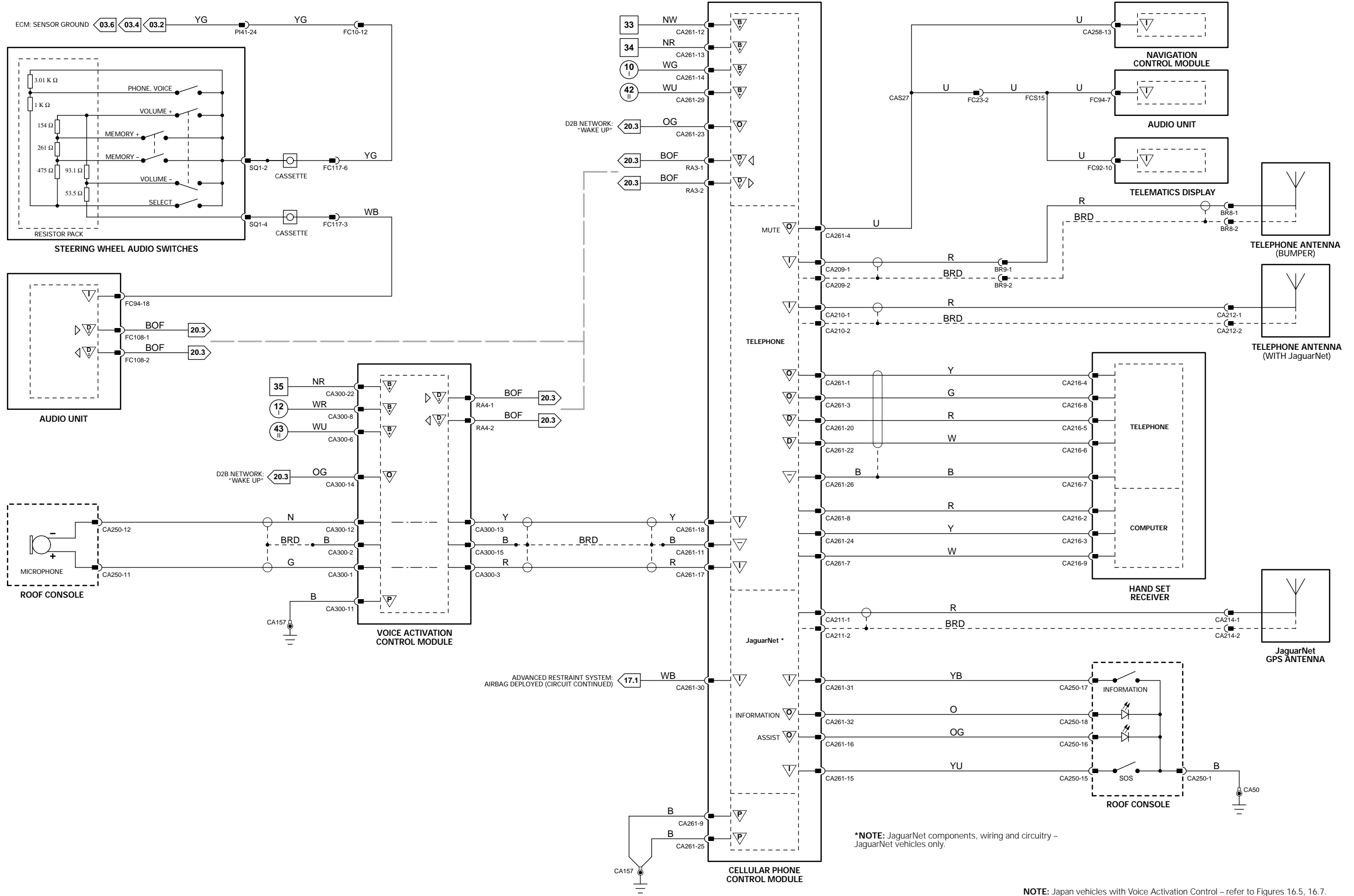

*NOTE: JaguarNet components, wiring and circuitry - JaguarNet vehicles only.

NOTE: Japan vehicles with Voice Activation Control - refer to Figures 16.5, 16.7.

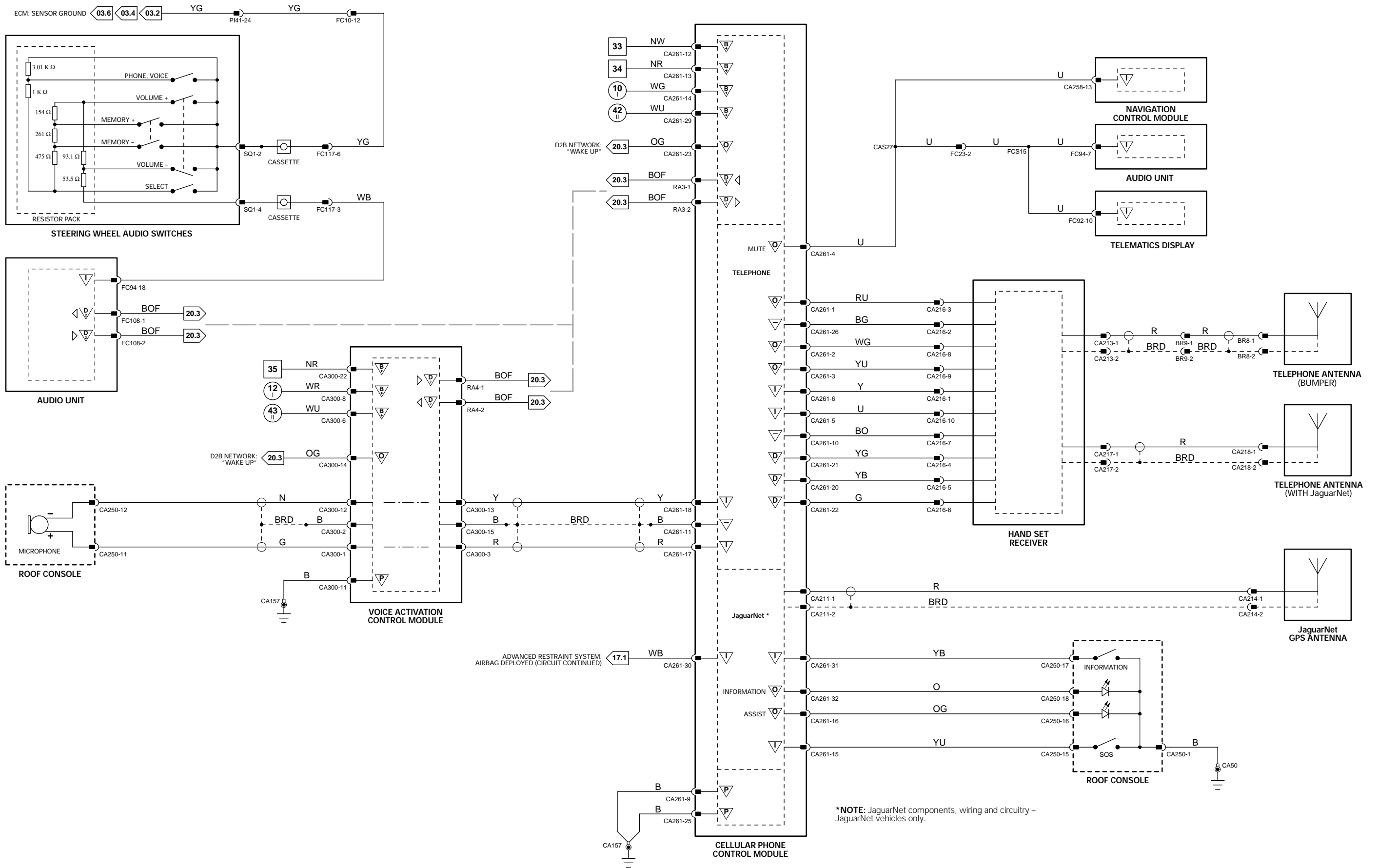

1 → 3 Fig. 01.1	4 → 76 Fig. 01.2	77 → 92 Fig. 01.3	1 → 14 Fig. 01.4	15 → 45 Fig. 01.5	46 → 80 Fig. 01.6	81 → 118 Fig. 01.7	Input	B Battery Voltage	∇ Sensor/Signal Supply V	∇ CAN	∇ D2B Network
			Output	P Power Ground	∇ Sensor/Signal Ground	S SCP	∇ Serial and Encoded Data				

VARIANT: NAS Vehicles
 VIN RANGE: All
 DATE OF ISSUE: March 2002 (PROVISIONAL)

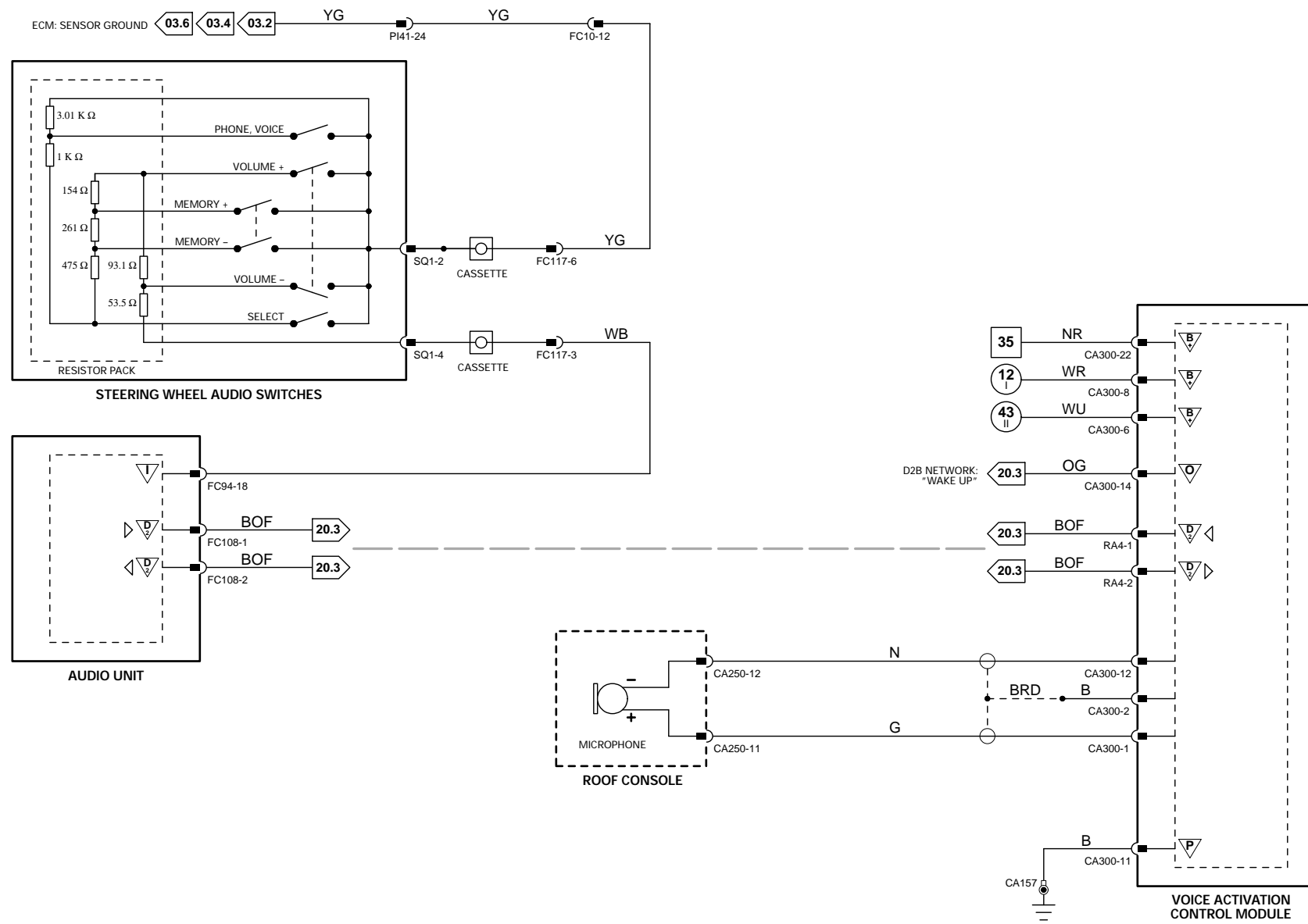

NOTE: Japan vehicles with voice activation control – Refer to Fig. 16.8.



VARIANT: Voice Only Vehicles
 VIN RANGE: All
 DATE OF ISSUE: March 2002 (PROVISIONAL)

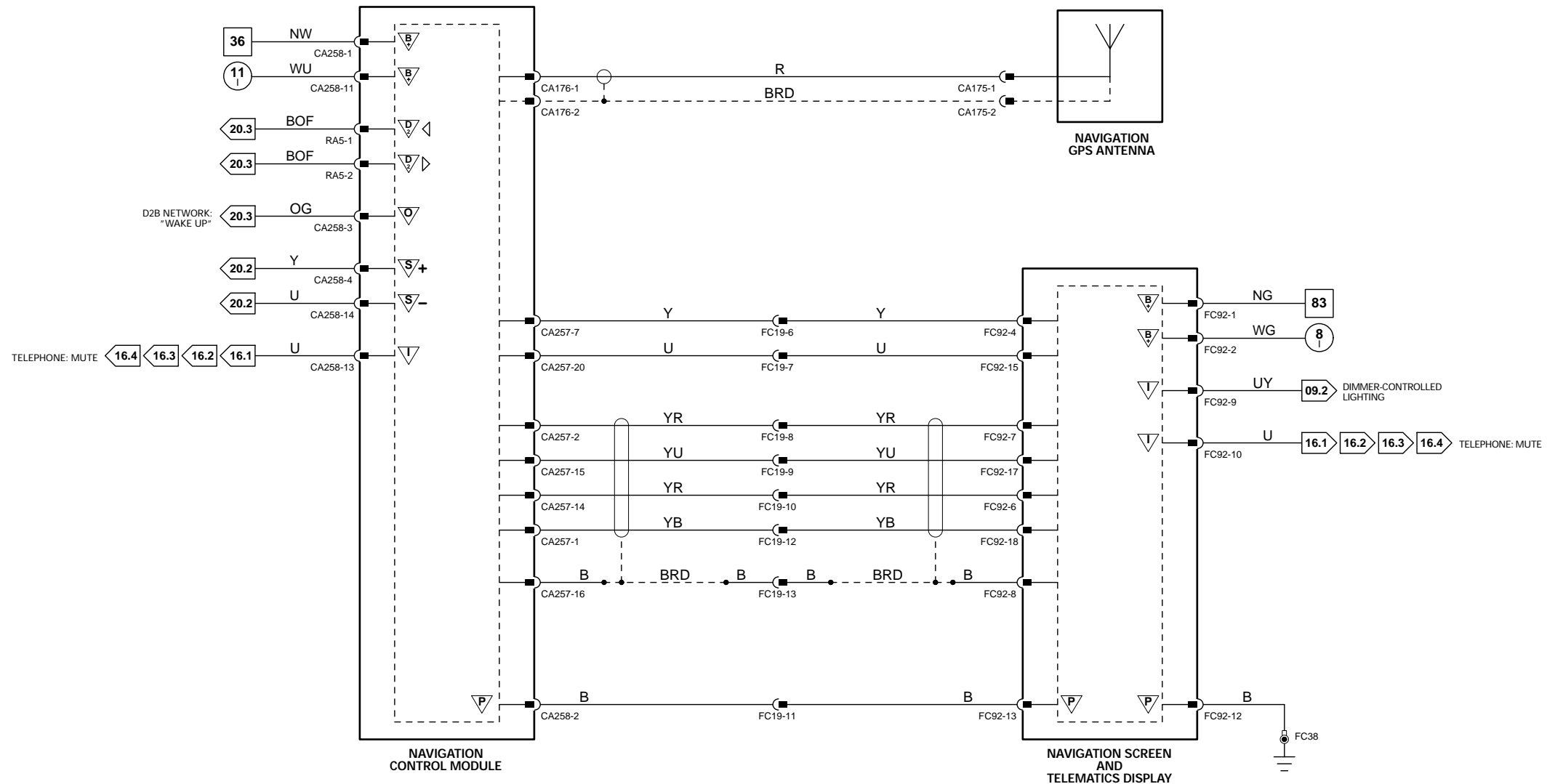

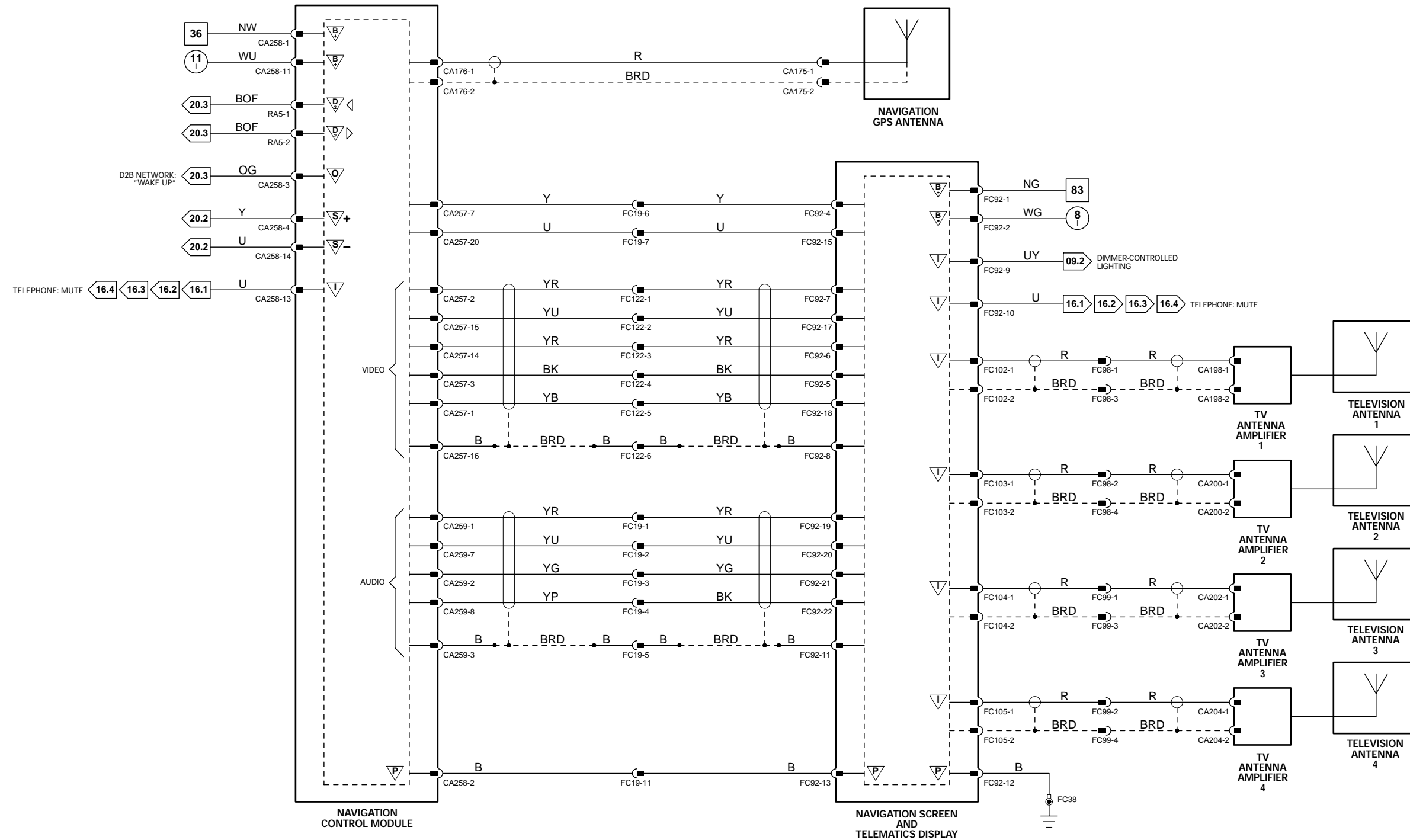

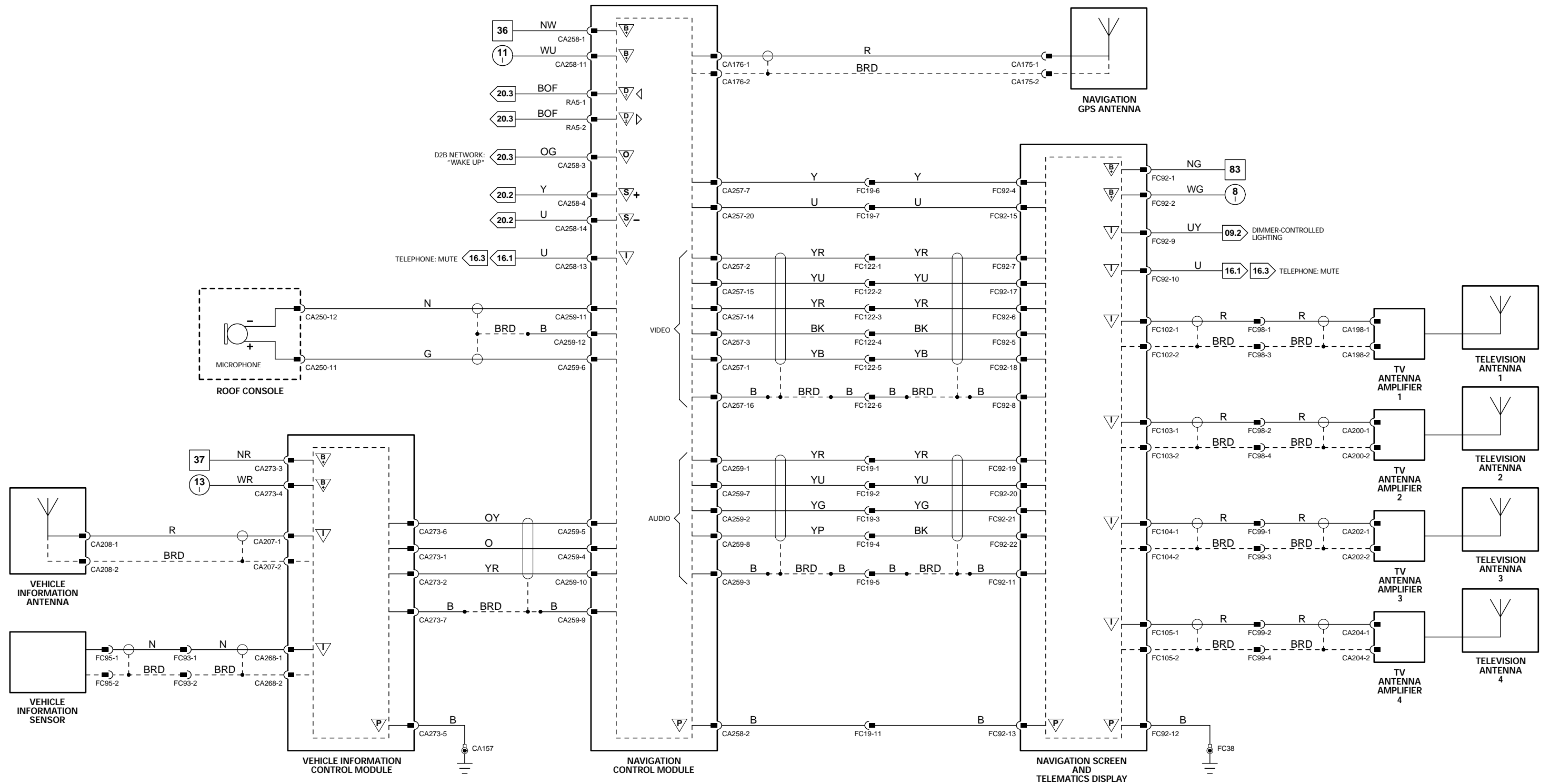

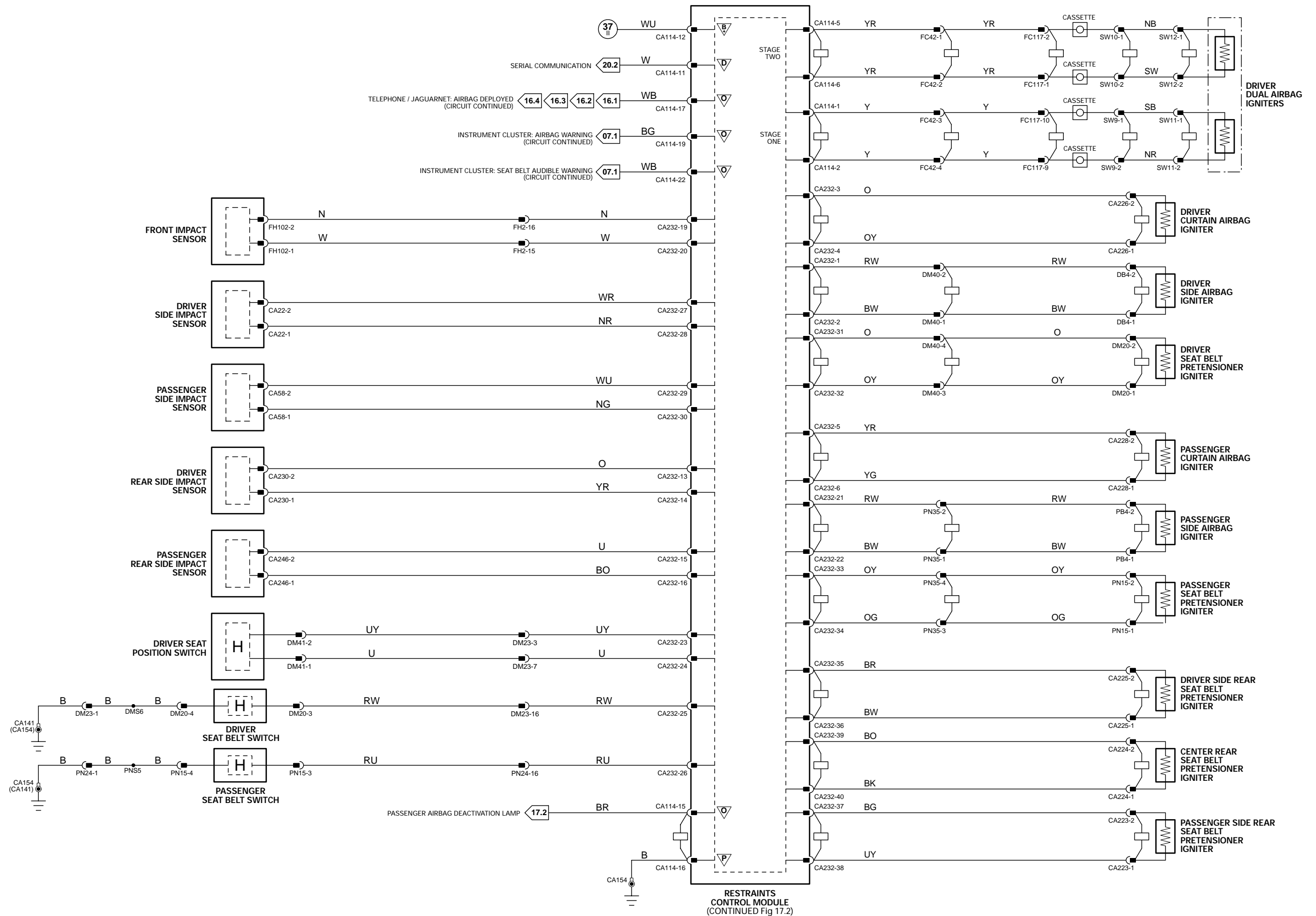

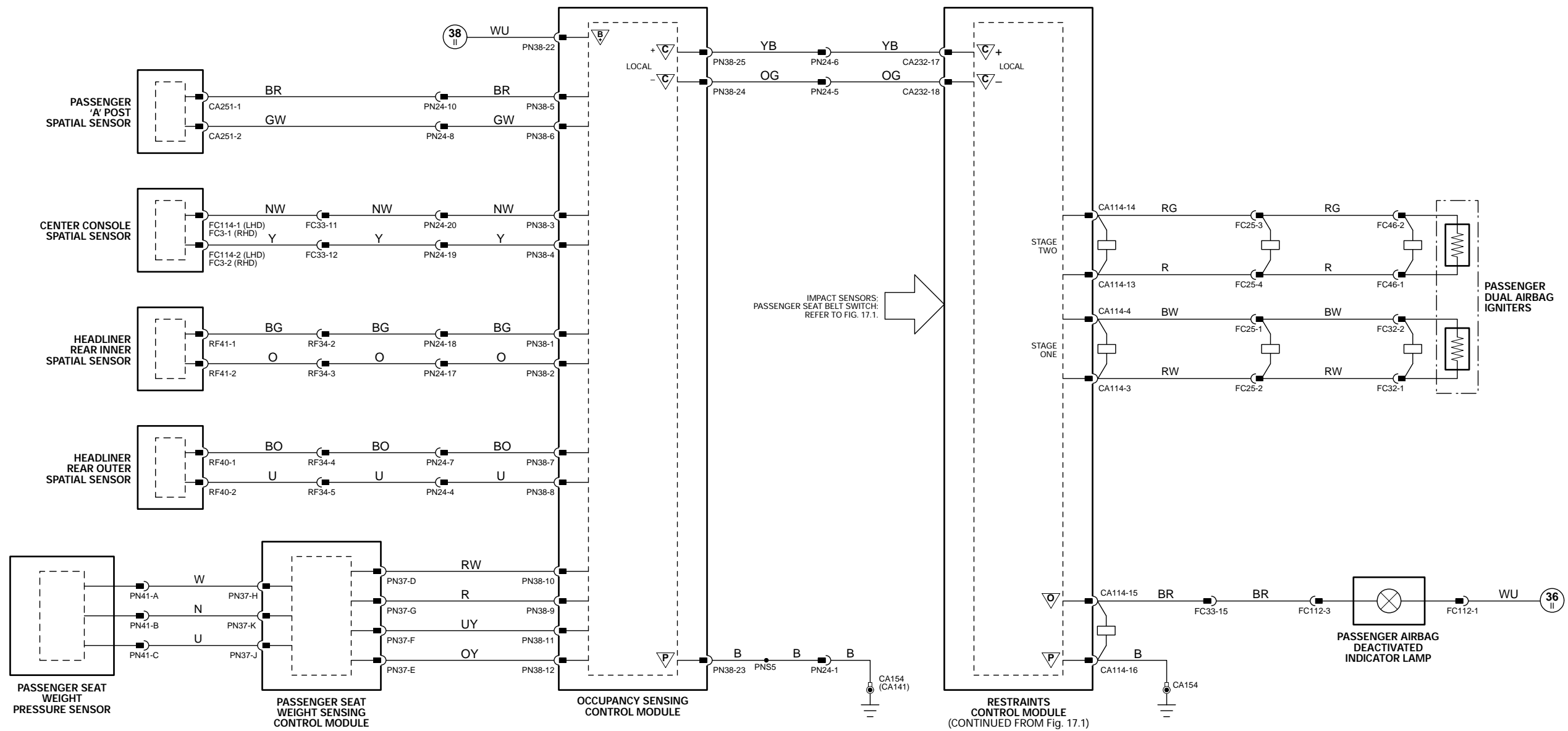

NOTE: RCM power supply shown on Fig. 17.1.

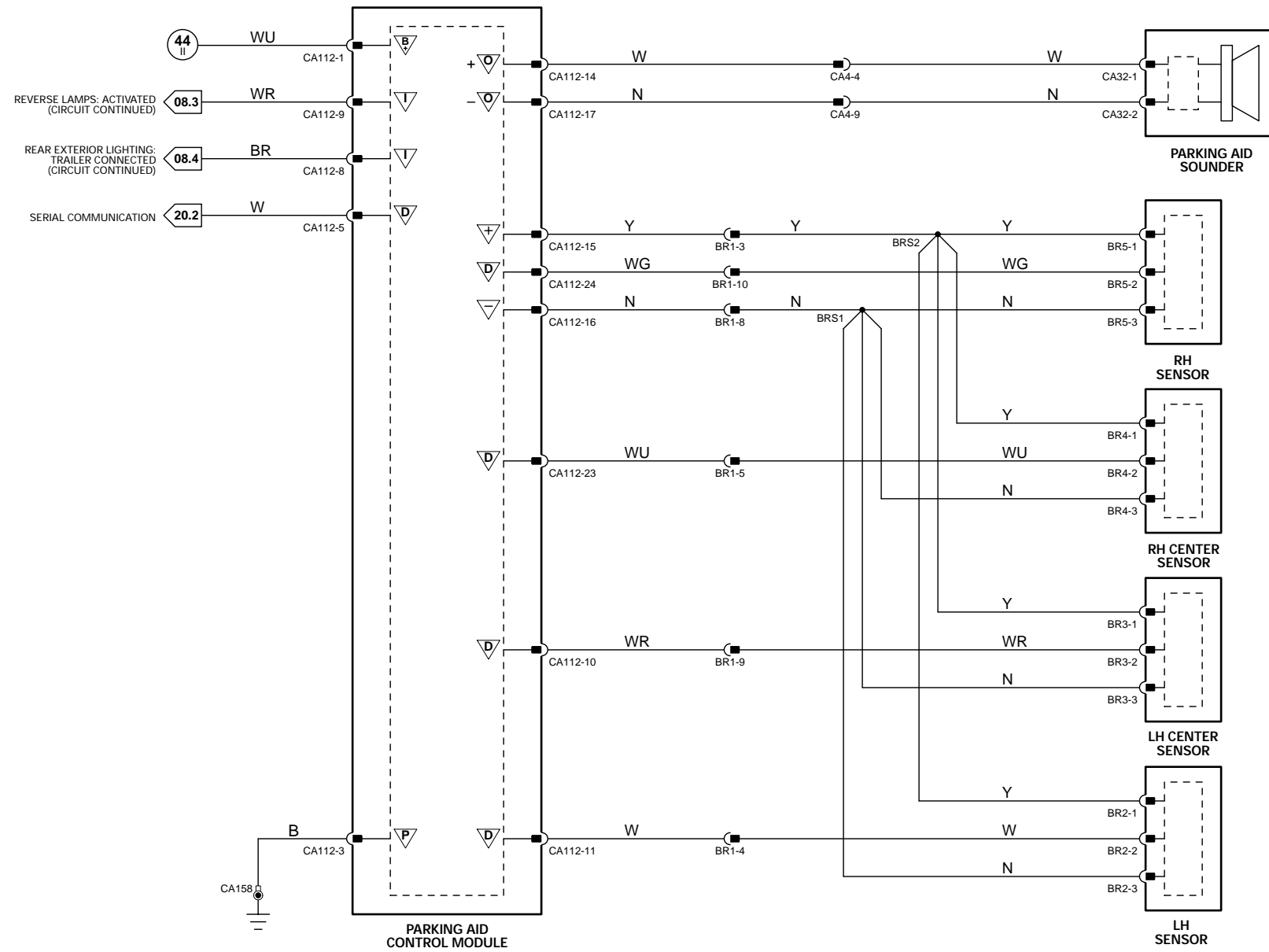

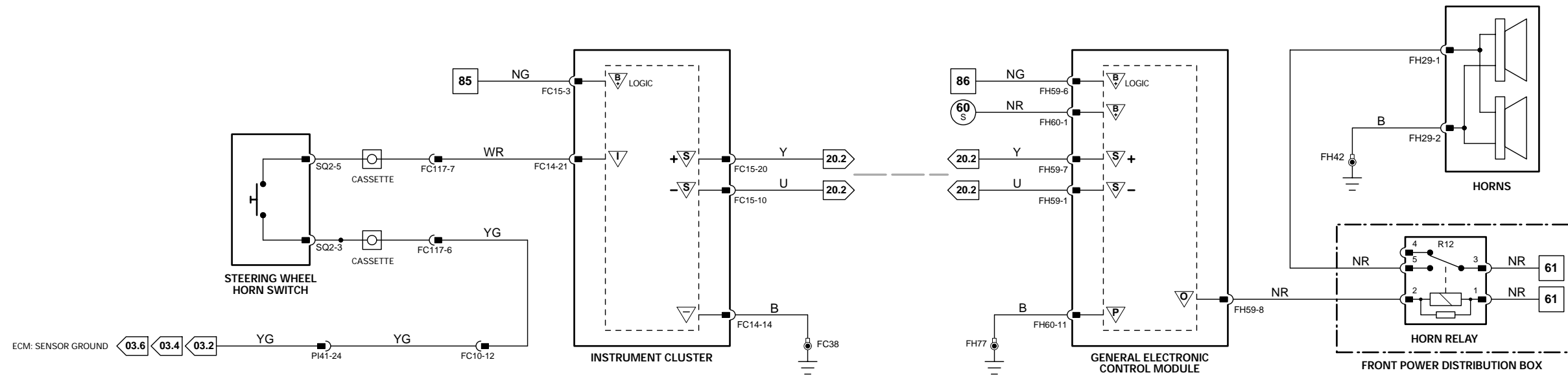

HORNS

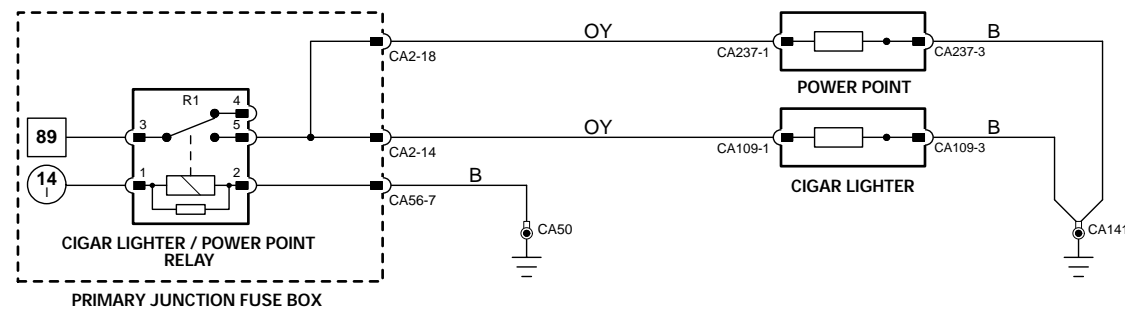

CIGAR LIGHTER; POWER POINT

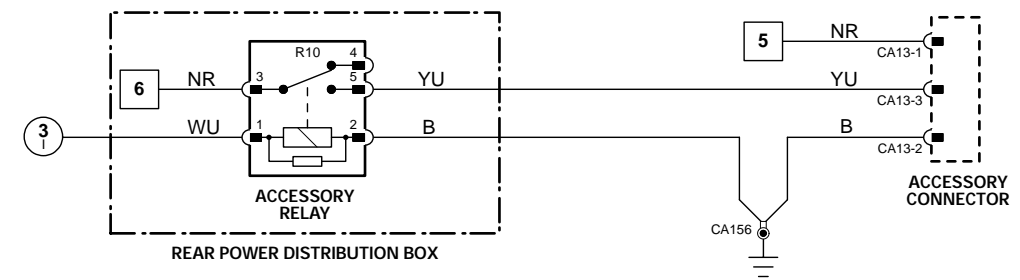

ACCESSORY CONNECTOR

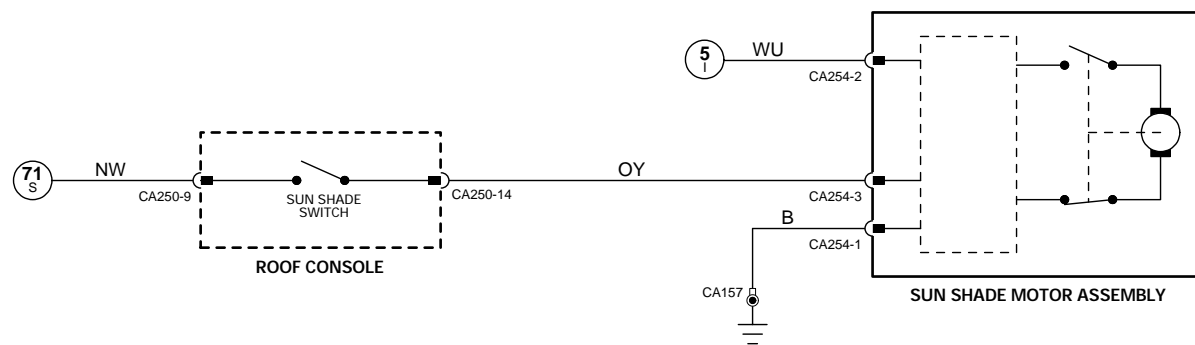

SUN SHADE

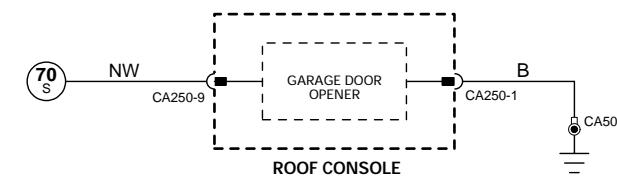

GARAGE DOOR OPENER

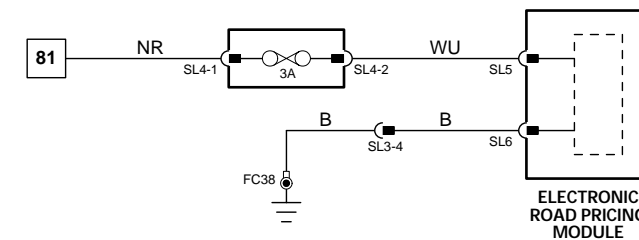

ELECTRONIC ROAD PRICING

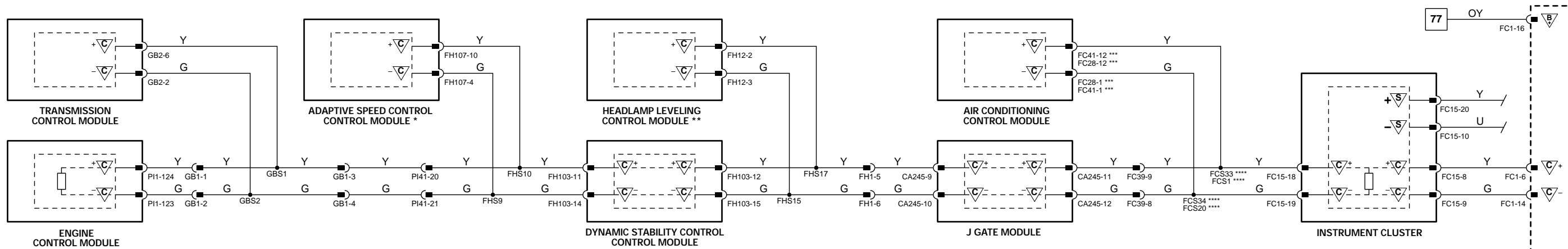

AUTOMATIC TRANSMISSION VEHICLES

NOTES:

- * Adaptive Speed Control Control Module and circuit – adaptive speed control vehicles only.
- ** Automatic Headlamp Leveling Control Module – HID vehicles only.
- *** FC41 – A/CCM with panel controls; FC28 – remote A/CCM with navigation.
- **** FCS33 and FCS34 – A/CCM with panel controls; FCS1 and FCS20 – remote A/CCM with navigation.

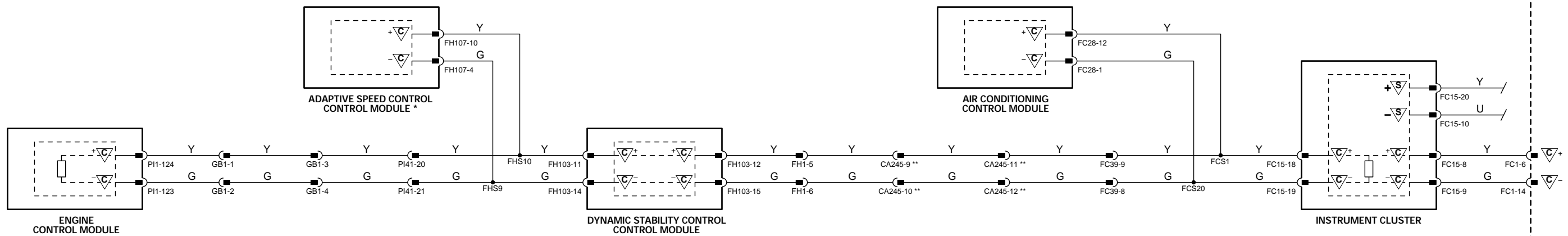

MANUAL TRANSMISSION VEHICLES

NOTES:

- * Adaptive Speed Control Control Module and circuit – adaptive speed control vehicles only.
- ** CA245 and circuit – fitted to certain vehicles only.

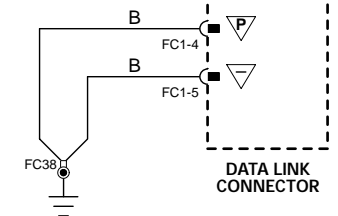

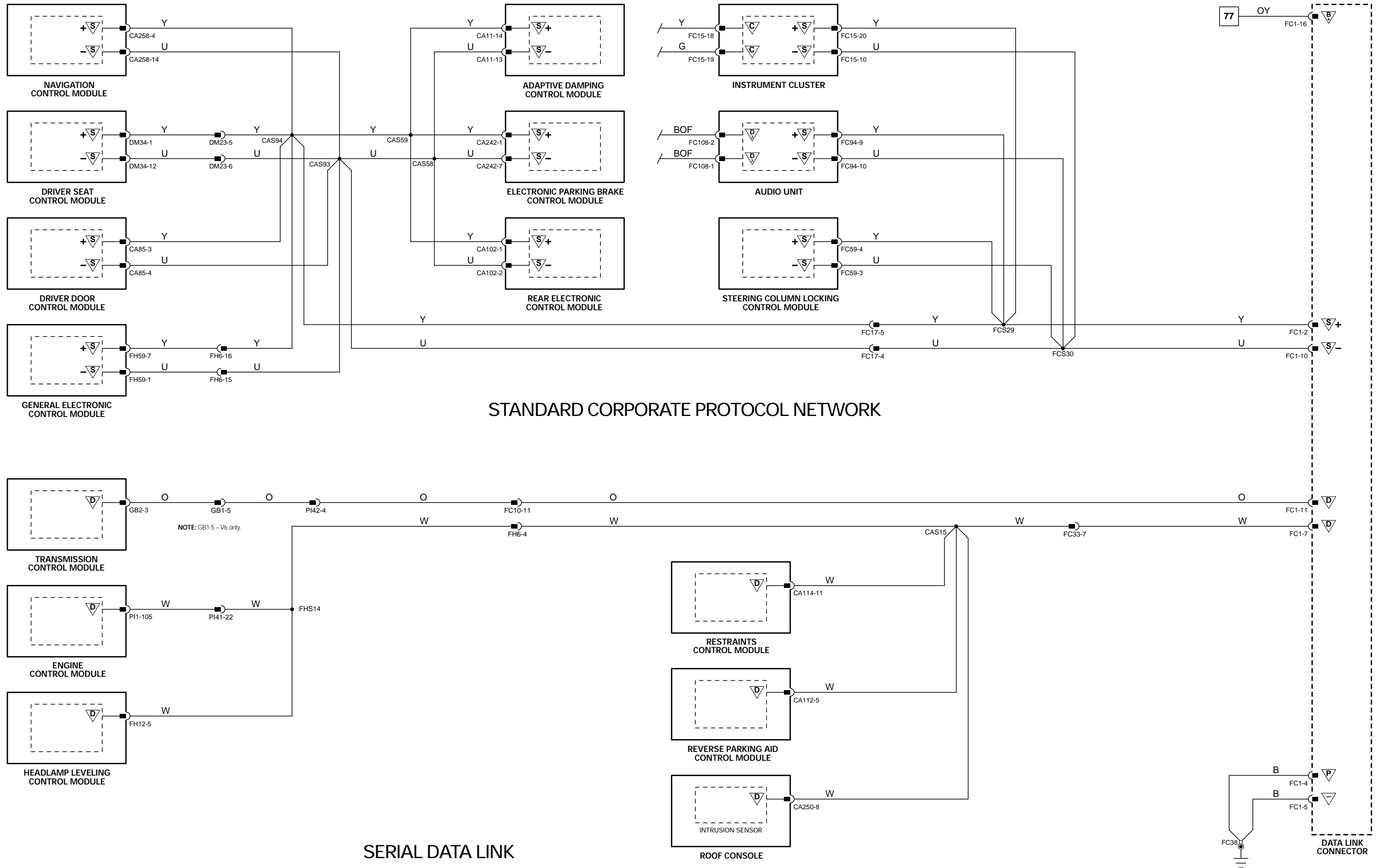

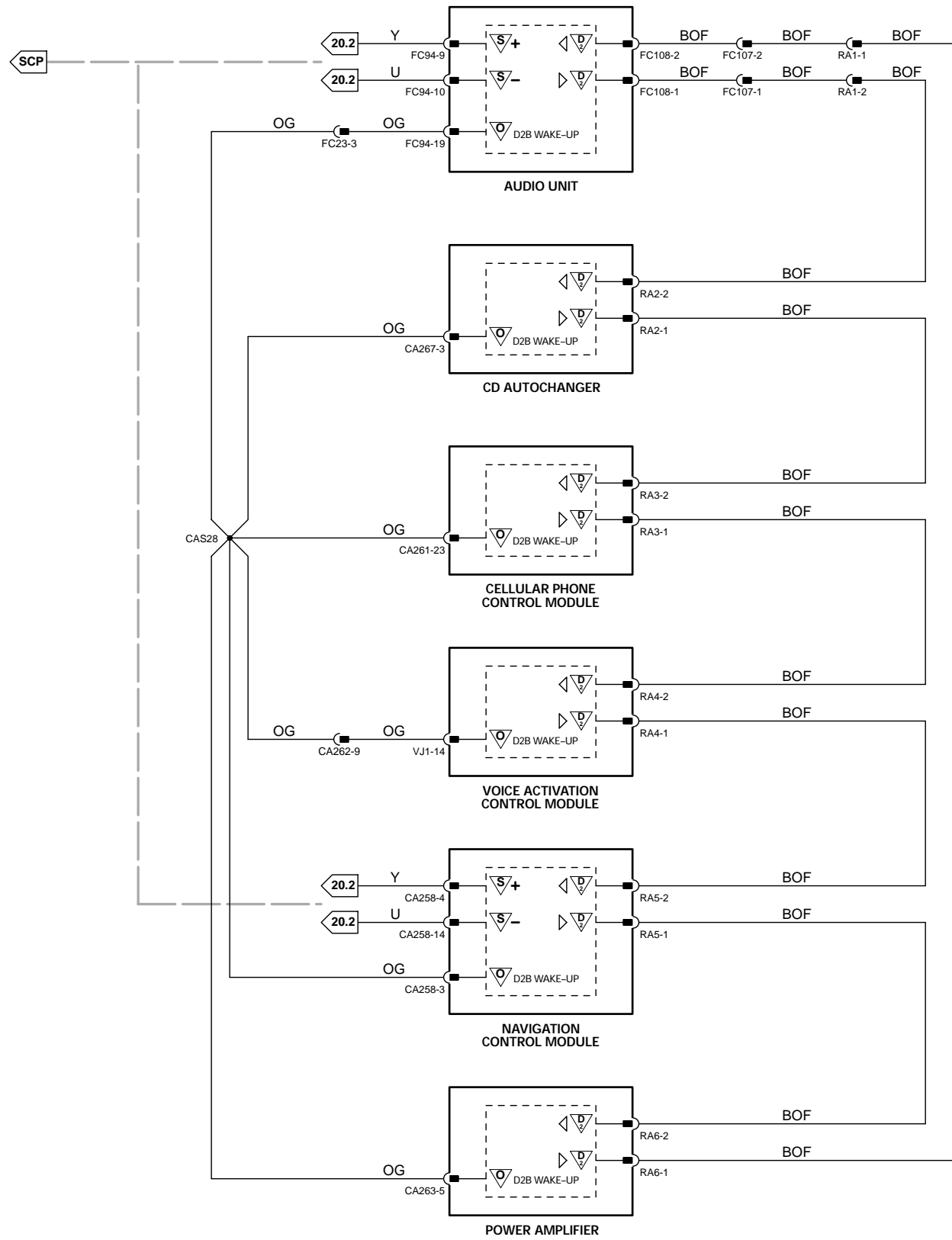

D2B NETWORK WAKE-UP; 6-MODULE NETWORK

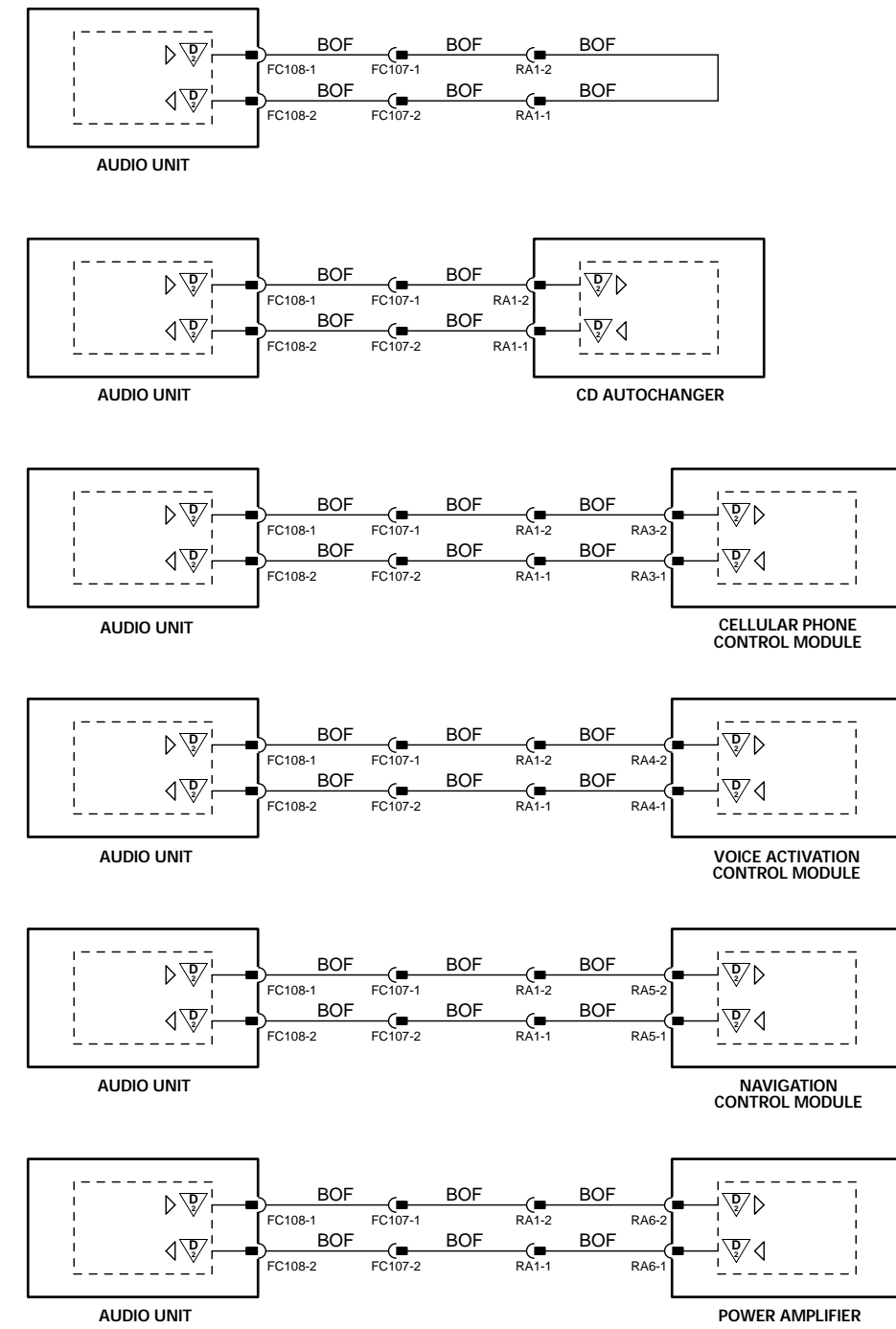

2-MODULE NETWORKS

NOTES:

Figures 20.3, 20.4 and 20.5 show all possible combinations of D2B networks. D2B network diagnostics via SCP - Refer to Fig. 20.2.

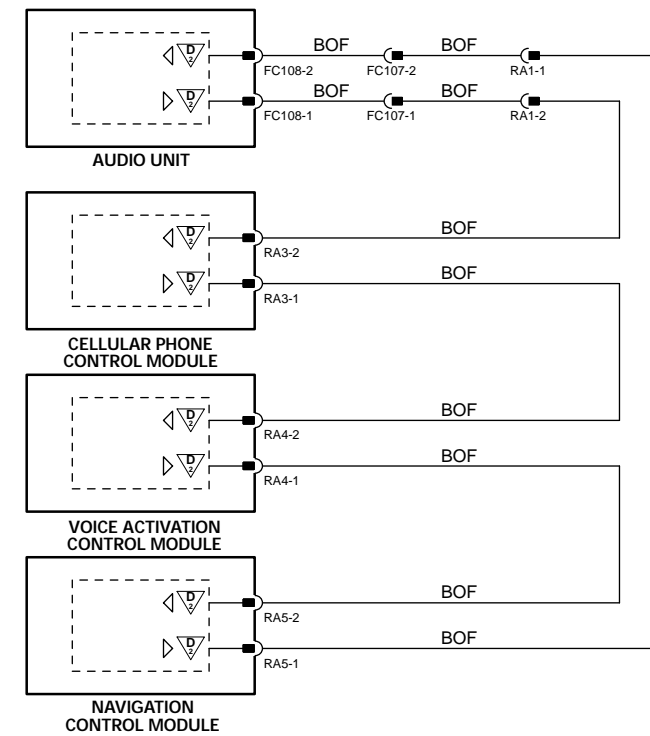
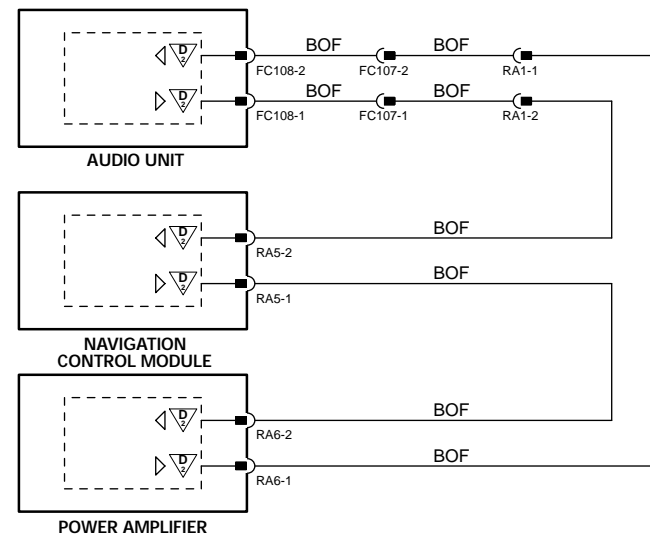
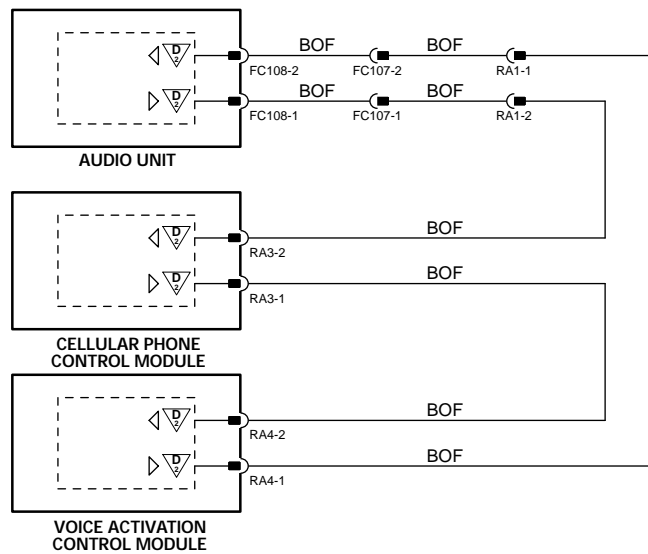
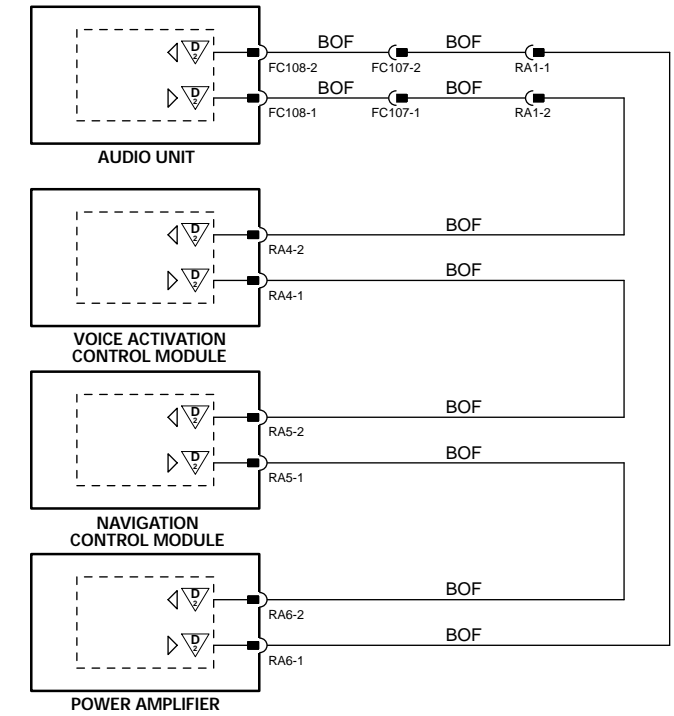
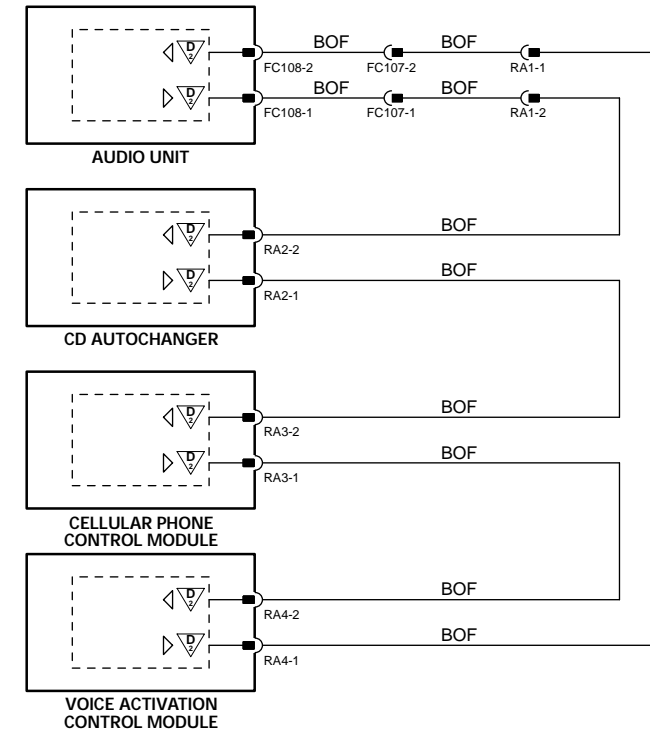
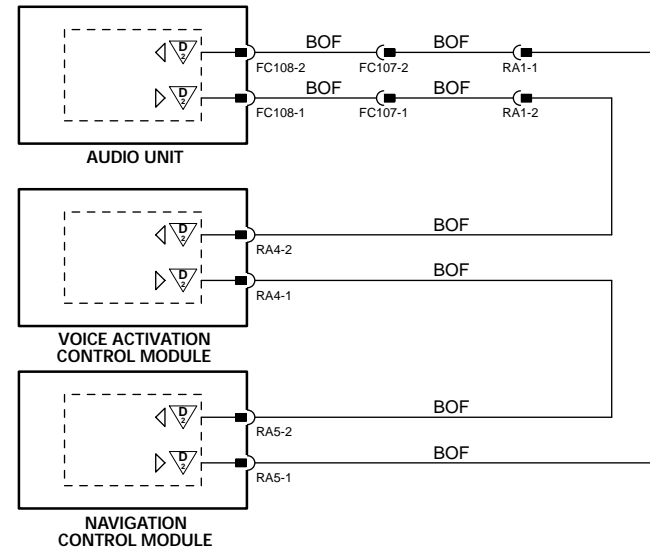
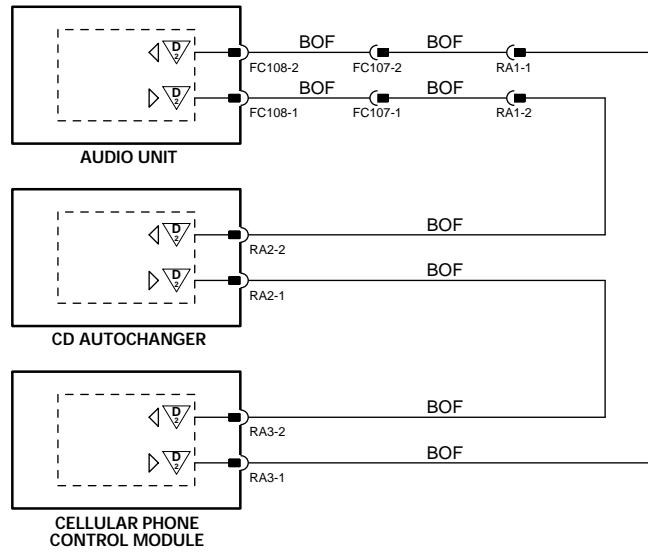

3-MODULE NETWORKS

4-MODULE NETWORKS

NOTES:

Figures 20.3, 20.4 and 20.5 show all possible combinations of D2B networks. D2B network diagnostics via SCP - Refer to Fig. 20.2.



VARIANT: All Vehicles
VIN RANGE: All
DATE OF ISSUE: March 2002 (PROVISIONAL)

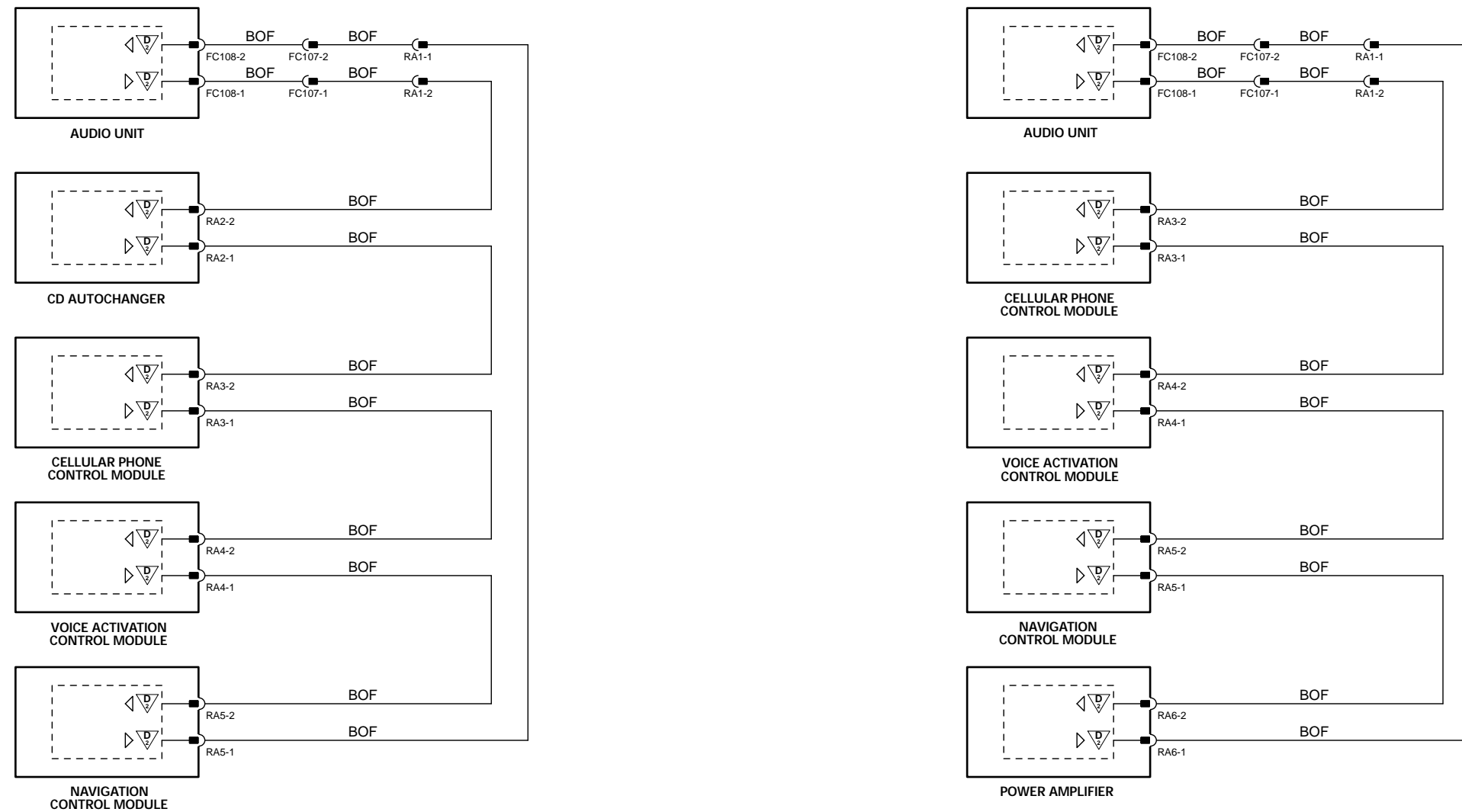

5-MODULE NETWORKS

NOTES:

Figures 20.3, 20.4 and 20.5 show all possible combinations of D2B networks. D2B network diagnostics via SCP – Refer to Fig. 20.2.