



## DOWNLOAD THE FREE APP!

OPEN APP STORE OR GOOGLE PLAY  
SEARCH AND INSTALL THE FREE  
"MIGHTY RUNNER" APP.



Note: An Additional cost may be incurred by downloading / going online.  
Check your data charges with your network provider.

### QUICK START

1. Move the ON/OFF switch on MIGHTY RUNNER to the ON position. After a while, LED will turn ON and start to blink quickly.
2. Tap MIGHTY RUNNER App icon from your supported devices's home screen to launch.  
When the App and the supported device connected with MIGHTY RUNNER successfully via bluetooth, LED will become solid ON.

[Tip] Make sure the bluetooth of your supported device is turned ON

3. After successful bluetooth connection, you can enjoy the game now by playing on the MIGHTY RUNNER.

Note: Product should be placed on flat area.

Make sure people around you know you are playing MIGHTY RUNNER.

### TROUBLESHOOTING

1. If MIGHTY RUNNER CANNOT be connected with App and supported device after a certain of period, it will go into sleep mode. LED will turn OFF.

[Tip] You need to move the ON/OFF switch on MIGHTY RUNNER to the OFF and then ON position again. Make sure the MIGHTY RUNNER App is launched.

2. If you close the MIGHTY RUNNER App, the Bluetooth connection will be lost. LED will blink quickly again.

[Tip] You need to launch the MIGHTY RUNNER App again for Bluetooth reconnection.

3. If you move your supported device away from MIGHTY RUNNER, the connection may be lost. LED will blink quickly again.

[Tip] You need to move your supported device back to MIGHTY RUNNER for Bluetooth reconnection.

### BATTERY SAFETY INFORMATION

**⚠ WARNING!** Battery acid leakage can cause personal injury and cause damage to the product and surrounding property. If battery leakage occurs, thoroughly wash any affected skin, making sure to keep battery acid away from eyes, ears, nose and mouth. Immediately wash any clothing or other surface that comes in contact with leaked battery acid. Leaking batteries may make "popping" sounds. Dispose according to Local, State or Federal Battery Laws.

#### TO AVOID BATTERY PROBLEMS:

NEVER mix old and new batteries or different brands of batteries.  
NEVER mix alkaline, standard (carbon-zinc), rechargeable batteries with this product.  
NEVER dispose of batteries in fire, as they may leak and explode.  
ALWAYS remove exhausted batteries from toy.  
ALWAYS have an adult install batteries consistent with installation instructions.  
ONLY use batteries specified by manufacturer.  
Batteries are to be inserted with the correct Polarity.  
The supply terminals are not to be short-circuited.  
Non-rechargeable batteries are not to be recharged.  
Rechargeable batteries are to be removed from the toy before being charged.  
Rechargeable batteries are only to be charged under adult supervision.

**4** This device complies with FCC radiation exposure limits set forth for general population (uncontrolled exposure). This device must not be collocated or operating in conjunction with any other antenna or transmitter.

### JAKKS Pacific® Battery, Solar or Electrically-Operated Toy 90 DAY LIMITED WARRANTY

Thanks for purchasing a great JAKKS Pacific® product! Please immediately register your product online at [www.jakks.com/warranty](http://www.jakks.com/warranty).  
Registration is not required for the effectiveness of this limited warranty.

#### IMPORTANT NOTICE TO CONSUMER:

This 90 DAY LIMITED WARRANTY applies to the original product purchaser, provided the product: 1) was purchased from an authorized JAKKS™ distributor/dealer/retailer, and 2) is returned at your expense, postage pre-paid and insured, along with the original dated sales receipt to the address noted below. Please save a copy of your original sales receipt, as the original receipt will not be returned to you. If you return the product to us without the original dated sales receipt, this warranty coverage will not apply. If the product is determined by JAKKS to be defective and returned to JAKKS within the 90 day warranty period, we will (at our option) repair or replace it. Return shipment to you may take up to 6 weeks, depending upon your location. If your product is repaired or replaced, it will be warranted for the longer of the original warranty or for 30 days after warranty service.

**SCOPE OF LIMITED WARRANTY:** The product is warranted to be: a) tested and inspected before shipment, and b) free of defects in material and workmanship for 90 days from date of purchase. If a covered defect occurs within the warranty period, then at our sole option, we will repair or replace the product or provide you with another product of equal value.

#### WHAT IS NOT COVERED BY LIMITED WARRANTY:

THIS WARRANTY IS VOID IF THE PRODUCT HAS BEEN MODIFIED OR REPAIRED BY USER OR OTHERS OR IF IT HAS BEEN DAMAGED AS A RESULT OF ACCIDENT, IMMERSION IN WATER, NEGLIGENCE, ABUSE, MISUSE, BATTERY LEAKAGE, IMPROPER BATTERY INSTALLATION, UNAUTHORIZED SERVICE, LOSS OF PARTS, WEATHER, ACTS OF GOD, ANY ACTION OR OMISSION WHICH CONSTITUTES A DEVIATION FROM THE OPERATING INSTRUCTIONS, OR ANY OTHER CAUSES NOT ARISING OUT OF DEFECTS IN WORKMANSHIP OR MATERIALS.

**EXCLUSIONS FROM LIMITED WARRANTY:** THIS WARRANTY IS EXCLUSIVE OF AND IN LIEU OF ALL OTHER EXPRESS OR IMPLIED WARRANTIES RELATED TO THIS PRODUCT, INCLUDING ANY IMPLIED WARRANTIES OF MERCHANTABILITY OR FITNESS FOR A PARTICULAR PURPOSE. SPECIAL, INCIDENTAL AND CONSEQUENTIAL DAMAGES ARISING FROM POSSESSION, USE, OR MALFUNCTION OF THIS PRODUCT ARE EXCLUDED BOTH FOR PROPERTY DAMAGE AND PERSONAL INJURY TO THE EXTENT LEGALLY PERMITTED.

**ADDITIONAL LEGAL RIGHTS:** This warranty provides specific legal rights. You may have other or different rights in your state or country.

**QUESTIONS OR COMMENTS:** If you experience product difficulties or have questions or comments, you may contact our Consumer Relations department as follows:  
Phone: 877-875-2557 (toll-free, North America only) or 909-594-7771 (Monday-Friday, 7:30AM-4:30PM Pacific/ GMT -8). Mail: JAKKS Consumer Relations, 21749 Baker Parkway, Walnut, California USA 91789. Email: [consumers@jakks.com](mailto:consumers@jakks.com)

**WHEN WRITING TO US:** Please include: 1) product name; 2) item number; 3) purchase date; 4) description of the problem being experienced; and 5) your name, address and phone number. Additionally, if eligible under the warranty and so advised by JAKKS Consumer Relations, also include the defective product and the ORIGINAL dated sales receipt evidencing product purchase. Please retain a copy of your receipt. 080309

### FCC

CAN ICES-3 (B)/NMB-3(B)

This device complies with Part 15 of the FCC Rules. Operation is subject to the following two conditions:

- (1) this device may not cause harmful interference, and
- (2) this device must accept any interference received, including interference that may cause undesired operation.

**WARNING:** Changes or modifications to this unit not expressly approved by the party responsible for compliance could void the user's authority to operate the equipment.

**NOTE:** This equipment has been tested and found to comply with the limits for Class B digital device, pursuant to Part 15 of the FCC Rules. These limits are designed to provide reasonable protection against harmful interference in a residential installation. This equipment generates, uses and can radiate radio frequency energy and, if not installed and used in accordance with the instructions, may cause harmful interference to radio communications. However, there is no guarantee that interference will not occur in a particular installation. If this equipment does cause harmful interference to radio or television reception, which can be determined by turning the equipment off and on, the user is encouraged to try to correct the interference by one or more of the following measures:

- Reorient or relocate the receiving antenna.
- Increase the separation between the equipment and receiver.
- Connect the equipment into an outlet on a circuit different from that to which the receiver is connected.
- Consult the dealer or an experienced radio/TV technician for help.



5-10  
years

### INSTRUCTION SHEET



**MAX WEIGHT : 105 lbs**  
**MAX USER : 1**

TM & © 2017 MANUFACTURED BY JAKKS PACIFIC, INC.,  
2951 28TH STREET, SANTA MONICA, CA 90405 U.S.A.









[www.jakks.com](http://www.jakks.com) - Hasdaq: JAKK

MADE IN CHINA  
Contents may vary in style, color, shape and decoration from images shown on package or in advertising  
Questions or comments? [www.jakks.com](http://www.jakks.com), [consumers@jakks.com](mailto:consumers@jakks.com), 1-877-875-2557 in North America or 01344 638909 in the United Kingdom.

ATTENTION! Remove and discard packaging ties and fasteners before giving toy to child. Warning. Not suitable for children under 36 months. Small parts. Choking hazard. Retain packaging as it contains important information.

### CAUTION: ADULT ASSEMBLY REQUIRED.

	<b>1 x DEVICE HOLDER</b>
	<b>2 x CLAMP</b>
	<b>4 x 1.25" (32mm) SMALL BOLT</b>
	<b>2 x RAILS</b>
	<b>4 x RODS</b>
	<b>4 x 2.25" (57mm) BIG BOLT</b>
	<b>1 x BASE</b>

### WHAT YOU'LL NEED



**"AA" (R6/LR6)  
BATTERIES**



**PHILLIPS HEAD  
SCREWDRIVER**

**NOT INCLUDED**

**A**



**WHAT YOU'LL NEED**



BASE / 1



RODS / 4



RAILS / 2

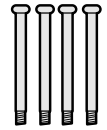

2.25" (57mm) BOLT / 4



Phillips Head Screwdriver (NOT INCLUDED)

**1**

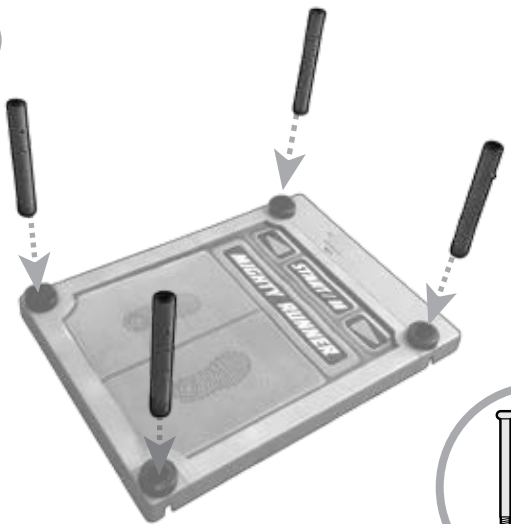

**3**

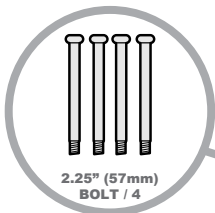
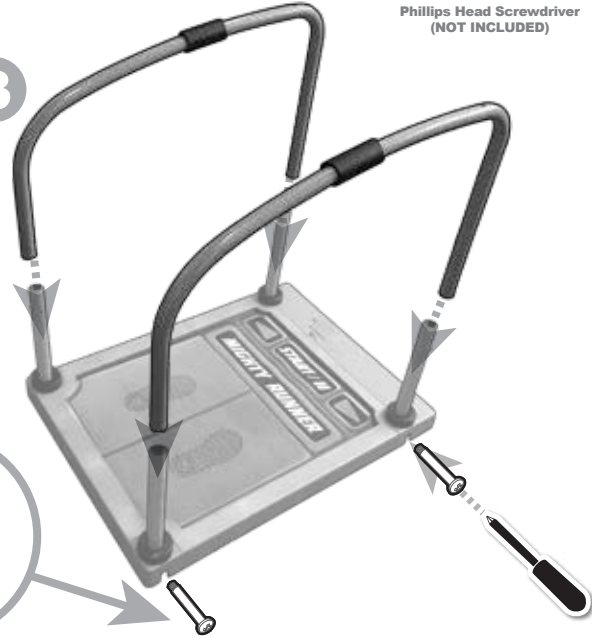

2.25" (57mm) BOLT / 4

**2**



**X 3 "AA" (R6/LR6) BATTERIES**



ADULT INSTALLATION REQUIRED

**BATTERY INSTALLATION INSTRUCTIONS**

Requires 3 "AA" (R6/LR6) batteries (Not included).

1. Located on top of Mighty Runner base.
2. Use "Phillips Head Screwdriver" (NOT INCLUDED), to remove the battery cover.
3. Install 3 "AA" (R6/LR6) batteries & replace the cover.

**B**



**WHAT YOU'LL NEED**



DEVICE HOLDER / 1



CLAMP / 2

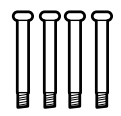

1.25" (32mm) BOLT / 4

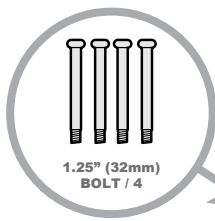

1.25" (32mm) BOLT / 4

**4**



**5**



**6**

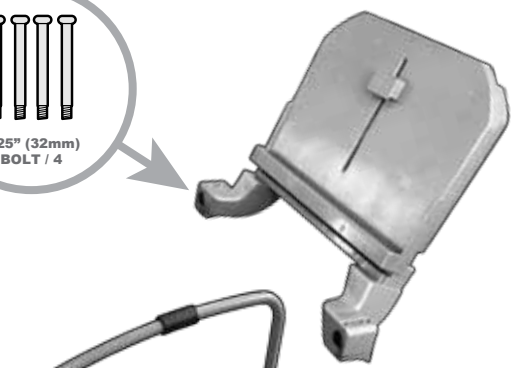

This device complies with Industry Canada licence-exempt RSS standard(s). Operation is subject to the following two conditions: (1) this device may not cause interference, and (2) this device must accept any interference, including interference that may cause undesired operation of the device. Under Industry Canada regulations, this radio transmitter may only operate using an antenna of a type and maximum (or lesser) gain approved for the transmitter by Industry Canada. To reduce potential radio interference to other users, the antenna type and its gain should be so chosen that the equivalent isotropically radiated power (e.i.r.p.) is not more than that necessary for successful communication.

Conformément à la réglementation d'Industrie Canada, le présent émetteur radio peut fonctionner avec une antenne d'un type et d'un gain maximal (ou inférieur) approuvé pour l'émetteur par Industrie Canada. Dans le but de réduire les risques de brouillage radioélectrique à l'intention des autres utilisateurs, il faut choisir le type d'antenne et son gain de sorte que la puissance isotrope rayonnée équivalente (p.i.r.e.) ne dépasse pas l'intensité nécessaire à l'établissement d'une communication satisfaisante. Le présent appareil est conforme aux CNR d'Industrie Canada applicables aux appareils radio exempts de licence. L'exploitation est autorisée aux deux conditions suivantes : (1) l'appareil ne doit pas produire de brouillage, et (2) l'utilisateur de l'appareil doit accepter tout brouillage radioélectrique subi, même si le brouillage est susceptible d'en compromettre le fonctionnement.

**2**

**3**