

# NASCAR

## INSTRUCTION MANUAL

Ages 8 +

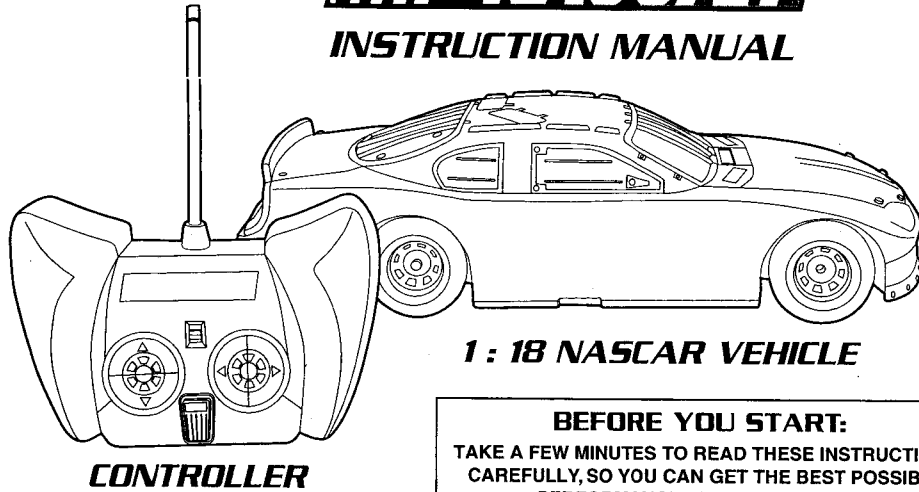

**BEFORE YOU START:**  
TAKE A FEW MINUTES TO READ THESE INSTRUCTIONS CAREFULLY, SO YOU CAN GET THE BEST POSSIBLE PERFORMANCE FROM THE NASCAR.

### THE NASCAR can be used indoors or outdoors.

**Indoors:** THE NASCAR will work on most surfaces including flat floors, tile.

**Outdoors:** THE NASCAR can be used outdoors on clean, hard, dry surfaces.

(SPIN OUT FEATURE WORKS BEST ON SMOOTH FLAT SURFACE)  
NEVER RUN THE NASCAR THROUGH WATER, SAND or DIRT. DAMAGE TO MOTORS AND GEARS WILL RESULT AND YOUR WARRANTY WILL BE VOIDED!

#### Radio Interference:

- Interference can be caused by a variety of devices both inside and outside.
- If the NASCAR is not responding to the signal from the transmitter, try using The NASCAR in a different location or at a different time.

#### Packaging screws must be removed by an adult.

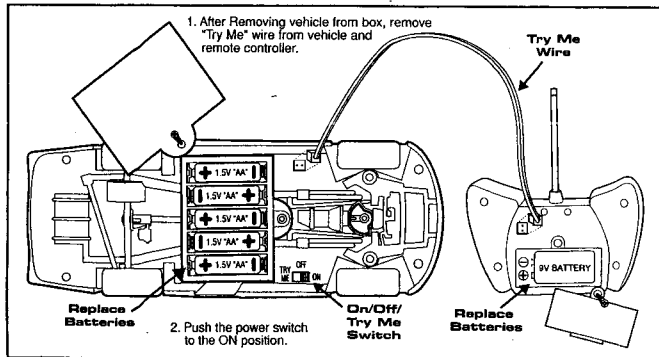

### BATTERY REQUIREMENTS:

The Set requires 5 AA batteries (3 AA batteries included) and one 9V battery (Not included).

### INSTALL THE 9V BATTERY IN CONTROLLER

A standard 9V alkaline battery (not included) provides power to the controller.

- ▲ Unscrew the battery compartment cover located on the back of the controller with a phillips screwdriver and remove.
- ▲ Carefully follow the diagram in the compartment, insert the battery as shown.
- ▲ Be sure the "+" on the battery is in the correct position.
- ▲ Install the antenna into controller.

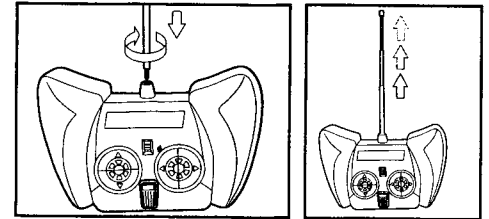
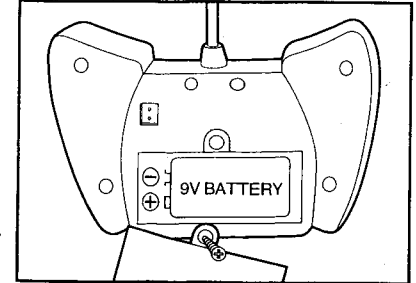

### TO OPERATE THE NASCAR:

- ▲ Turn the CONTROLLER power switch to the "ON" position & extend the antenna.
- ▲ Turn the NASCAR power switch to the "ON" position.

#### The Controller:

The controller has 5 buttons: Press the brake button to enable special "Spin out" Feature.

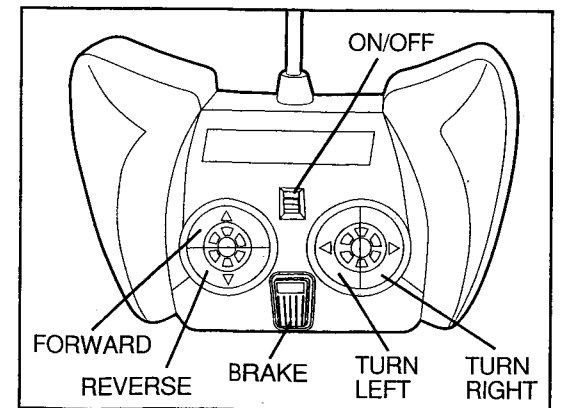
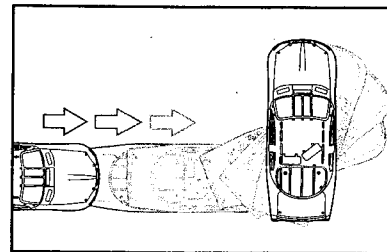

- ▲ The two buttons on the left command forward or backward.
- ▲ The two buttons on the right command left or right.

## INSTALL THE BATTERY IN NASCAR

1. Switch the power to "OFF".
2. Unscrew the battery compartment cover located on the back of the handset with a Phillips screwdriver and remove.
3. Insert 5 AA (1.5V) Alkaline batteries in the proper direction as indicated inside the battery compartment.
4. Replace the battery cover & tighten screw securely.
5. Switch the power to "ON"

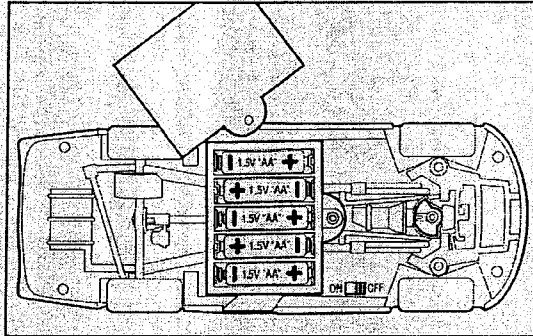

## THE NASCAR TUNE-UP: STEERING ADJUSTMENT

1. Adjust your NASCAR steering by rotating the Steering Knob bit by bit.
2. After you have made an adjustment, place your NASCAR on the ground and take it for a spin!
3. Simply repeat these simple steps until you get the best steering action for your NASCAR.

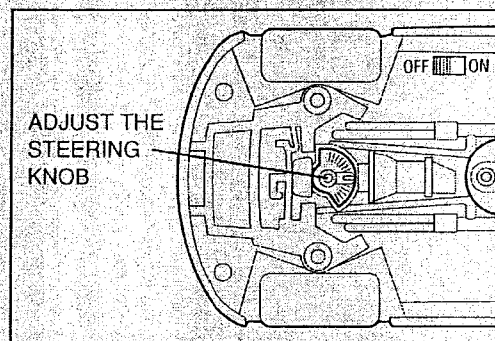

For 27 MHz :

Field Strength : 54.2 dB $\mu$ V/m at 3 m

For 49 MHz :

Field Strength : 51.5 dB $\mu$ V/m at 3 m

## SAFE BATTERY PRECAUTIONS

- Do not dispose the batteries in fire; batteries may leak or explode.
- Different types of batteries or new and used batteries are not to be mixed.
- Only batteries of the same or equivalent type as recommended are to be used.
- The supply terminals are not to be short-circuited.
- Non-rechargeable batteries are not to be recharged.
- When not in use for an extended time, remove batteries to prevent possible leakage.
- Batteries are to be inserted with the correct polarity.
- Exhausted batteries are to be removed from the toy.
- Batteries should be replaced by adult.
- Please retain the packing or this portion in case of complaint.

## IMPORTANT:

- MODIFICATIONS NOT AUTHORIZED BY THE MANUFACTURER MAY VOID USER'S AUTHORITY TO OPERATE THIS DEVICE.
- EMISSIONS OR INTERFERENCE OF SURROUNDING ELECTRONIC EQUIPMENT MAY AFFECT OPERATING PERFORMANCE.

## CAUTION:

- Do not use rechargeable batteries for the Remote Control Handset and/or the External Charger.
- Not suitable for children under 3 years.
- May contain small parts.

## NOTES:

This equipment has been tested and found to comply with limits for a Class B digital device, pursuant to Part 15 of the FCC Rules. These limits are designed to provide reasonable protection against harmful interference in a residential installation. This equipment generates, uses and can radiate radio frequency energy and, if not installed and used in accordance with the instruction, may cause harmful interference to radio communications. However, there is no guarantee that interference will not occur in a particular installation. If this equipment does cause harmful interference to radio or television reception, which can be determined by turning the equipment off and on, the user is encourage to try to correct the interference by one or more of the following measures:

- Reorient or relocate the receiving antenna.
- Increase the separation between the equipment and receiver.
- Connect the equipment into an outlet on a circuit different from that to which the receiver is connected.
- Consult the dealer or an experienced radio/TV technician for help.

This device complies with Part 15 of the FCC Rules Operation is subject to the following two conditions: (1) This device may not cause harmful interference; and (2) This device must accept any interference received, including interference that may cause undesired operation.

## WARNING!

*Changes or modifications to this unit not expressly approved by the party responsible for compliance could void the user's authority to operate the equipment.*

## TROUBLE SHOOTING

Problem	Likely Cause	Solution
Vehicle will not run or seems sluggish	Loose battery connection	Check battery connector
	Vehicle switch not "ON"	Move switch to the "ON" position
	Vehicle battery weak	Charge or replace battery
Vehicle doesn't work after getting wet from water or snow	Weak transmitter (controller) battery	Replace with fresh alkaline battery
	Water in the electronics bay	Thoroughly dry vehicle before attempting to use again
Erratic or only short range operation	Radio Interference	Change location of operation
	2 vehicles on the same frequency	Operate only 1 vehicle per frequency
	Weak transmitter battery	Change 9V Alkaline battery