

- 4) **Set an ending bearing and range by turning the [EBL] dial and [VRM] dial, and left-click.**



When the automatic activation function is enabled, the filter range is automatically changed for covering the automatic activation zone. Thus, the automatic activation zone is always within the filter range.

#### 5.3.7.4 AIS Filter Display On/Off (Filter Display)

##### Procedures

- 1) **Open the AIS Filter Setting menu by performing the following menu operation.**

AIS



4. AIS Filter Setting

- 2) **Left-click the item button of 3. Filter Display .**

Filter Display will be set to on or off.

#### 5.3.7.5 Display of Targets outside AIS Filter (Filter Mode)

##### Procedures

- 1) **Open the Filter Mode menu by performing the following menu operation.**

AIS



4. AIS Filter Setting

- 2) **Left-click the item button of 6. Filter Mode .**

Display

: Displays only AIS targets in the AIS filter.

Priority

: Displays AIS targets in the AIS filter by priority, and also displays targets outside the AIS filter.



Activated AIS targets can be displayed even when they are outside the AIS filter.

### 5.3.7.6 Point Filter

AIS targets which are not displayed because they are outside the AIS filter or at low priority levels can be activated by giving a higher priority to them.

#### Procedures

- 1) Put the cursor on the position where a point filter is to be set, and right-click to select the filter to be set.

- 2) The setting items for cursor modes will be displayed. Left-click **2. ACT AIS**.

A point filter will be set at the cursor position.

If an AIS target is in the point filter, it will be activated.

When an AIS target is activated or an AIS target is not found within one minute, the point filter will be cleared.



The point filter's range is 1 nm, and cannot be changed.

### 5.3.8 Conditions for Deciding AIS Target to be Lost

#### About a lost target

When the data of an AIS target cannot be received for a specified time, the target is decided to be lost and the target data is deleted. As shown in the table below, the time until target data is deleted varies depending on the class of receive data and the target status.

Deciding AIS Target to be Lost

Target status	Time until data deletion	
	SOLAS ship (Class A)	SOLAS ship (Class B)
Vessel below 3 knots (Class A) or 2 knots (Class B) and it is now at anchor or on the berth	18 min	18 min
Vessel of 3 knots or more and it is now at anchor or on the berth	60 sec	18 min
Vessel of 0 to 14 knots (Class B: 0 to 14 knots)	60 sec	180 sec
Vessel of 14 to 23 knots	36 sec	180 sec
Vessel of 23 knots or more	30 sec	180 sec
SAR (Search and Rescue)	60 sec	60 sec
ATON (Aid to Navigation)	18 min	18 min
Base Station	60 sec	60 sec



When a dangerous target ship is lost, a lost alarm is issued and the symbol changes to a lost symbol. The lost symbol will display continuously on the last-received position.

If the [ALARM ACK] key is pressed, the symbol is cleared.

### 5.3.9 Setting Conditions for AIS Alarm (AIS Alarm Setting)

Conditions for issuing a Lost alarm and CPA/TCPA alarm for AIS targets can be set.

#### 5.3.9.1 Setting of Condition for Lost Alarm

##### Procedures

- 1) Open the AIS Alarm Setting menu by performing the following menu operation.

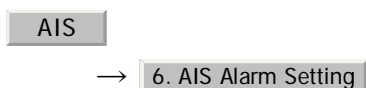

- 2) Left-click the item button of **1. Lost Alarm** .

The setting items for Lost Alarm will be displayed.

- 3) Left-click the item button corresponding to the condition to be set.

**Off** : A lost alarm is not issued.<sup>i</sup>

**Danger** : A lost alarm is issued only for AIS targets for which a dangerous target alarm has been issued.

**ACT&Danger** : A lost alarm is issued only for activated AIS targets and AIS targets for which a dangerous target alarm has been issued.

**ACT&Danger&Select** : A lost alarm is issued only for activated AIS targets, data indicated AIS targets and AIS targets for which a dangerous target alarm has been issued.

i. A lost alarm is not issued for sleeping AIS targets.

#### 5.3.9.2 Setting of Condition for CPA/TCPA Alarm

##### Procedures

- 1) Open the AIS Alarm Setting menu by performing the following menu operation.

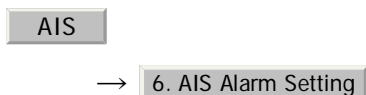

- 2) Left-click the item button of **CPA/TCPA Alarm** .

The setting items for CPA/TCPA Alarm is switched.

**Off** : A CPA/TCPA alarm is not issued.<sup>i</sup>

**ACT** : A CPA/TCPA alarm is issued only for activated AIS targets.

**ACT&Sleep** : A CPA/TCPA alarm is issued for all AIS targets on the radar display.

i. When the Lost Alarm menu set to Off, the CPA ring color changes to dark color.

## 5.4 DECISION OF TARGETS AS IDENTICAL (Association)

### 5.4.1 Setting of Function to Decide Targets as Identical (Association)

When an AIS target and a tracking target are decided to be identical, an association symbol is displayed for the targets regarded as identical. In this case, the AIS target symbol is automatically activated.

#### Attention

- Turn off **Association** in order not to make a decision on if targets are identical, or in order to display symbols that have disappeared.

#### Procedures

- 1) Left-click the **Association** in Target Information located at the upper right of the display.

Association will be set to on or off.

### 5.4.2 Setting of Conditions for Deciding AIS and Tracked Targets as Identical (Association Setting)

#### Procedures

- 1) Open the Association Setting menu by performing the following menu operation.

AIS

→ 1. Association Setting

The Association Setting menu will appear.

- 2) Select and enter the item to be set.

Conditions for deciding targets as identical will be set. When the differences of all item between AIS and tracked target are under the set conditions..

Once regard as identical, when one of the differences exceed 125% of the set condition, they are regarded as dissidence.



The setting for this function is common to Association Setting in the AIS Menu.

### 5.4.3 Types of Decision Conditions to be Set

Decision conditions	
1. Association	On / Off (Function to decide targets as identical)
2. Priority	AIS / TT (Symbol to be displayed)
3. Bearing	0.0 ~ 9.9°
4. Range	0 ~ 999m
5. Course	0 ~ 99°
6. Speed	0 ~ 99kn
7. Applicable AIS Target	ACT or ACT&Sleep (activated AIS target or all AIS target)



## CAUTION



If a great value is set as a condition for deciding targets as identical, a tracking target near an AIS target is regarded as identical to the AIS target and it may not be displayed any more.

For example, when a pilot boat (which is a small target not being tracked) equipped with an AIS function approaches a cargo ship as a tracking target not equipped with an AIS function, the tracking target symbol of the cargo ship may not be displayed any more.

# 5.5 ALARM DISPLAY

Critical alarm messages for Target Tracking (TT) and AIS functions:

Error message	Description
CPA/TCPA	There is a dangerous target. See also Section 5.5.1.

Alarm messages for Target Tracking (TT) and AIS functions:

Error message	Description
CPA/TCPA	There is a dangerous target.
New Target	A new target is acquired in the automatic acquisition zone.
Lost	There is a lost target.
REF Target	The accuracy of the reference target may be decreased.
95% Capacity	The number of targets being tracked by the Target Tracking function has reached 95% of the maximum.
MAX Target	The number of targets being tracked by the Target Tracking function has reached the maximum.
AIS 95% Capacity	The number of displayed AIS target symbols has reached 95% of the maximum.
AIS MAX Target	The number of received data items exceeds the maximum number of AIS target symbols that can be displayed.
AIS ACT 95% Capacity	The number of activated AIS targets by the AIS function has reached 95% of the maximum.
AIS ACT MAX	The number of activated AIS targets by the AIS function has reached the maximum.
AIS Alarm ***	Alarm information issued with the ALR sentence by the AIS. *** is a 3-digit number which is Local Alarm No in the ALR sentence. See below.
AIS Alarm 001	Tx malfunction
AIS Alarm 002	Antenna VSWR exceeds limit
AIS Alarm 003	Rx channel 1 malfunction
AIS Alarm 004	Rx channel 2 malfunction
AIS Alarm 005	Rx channel 70 malfunction
AIS Alarm 006	general failure
AIS Alarm 008	MKD connection lost
AIS Alarm 025	external EPFS lost
AIS Alarm 026	no sensor position in use
AIS Alarm 029	no valid SOG information
AIS Alarm 030	no valid COG information
AIS Alarm 032	Heading lost/invalid
AIS Alarm 035	no valid ROT information

5

Error message and alarm are displayed in the lower right of the display.

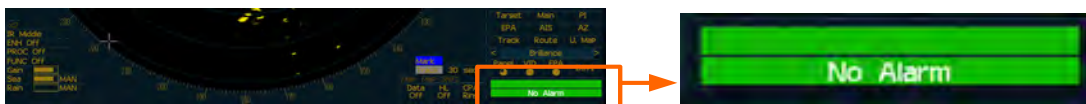

See also Section 9.1.1 "List of Alarms and other Indications".

### 5.5.1 CPA / TCPA Alarm



## CAUTION



**Since these alarms may include some errors depending on the target tracking conditions, the navigation officer himself should make the final decision for ship operations such as collision avoidance.**

**Making the final navigation decision based only on the alarm may cause accidents such as collisions.**





In the system, targets are categorized into two types: tracked / activate AIS targets and dangerous targets.

The grade of danger can easily be recognized on the display at a glance. So the officer can easily decide which target he should pay attention to.

It is not possible to switch off the tracked target visual alarm, unless tracking is ceased, or the alarm condition no longer applies.

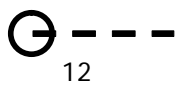
The types of target and alarm are shown below.

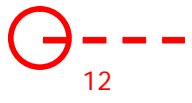
CPA / TCPA Alarm

Status	Symbol display	on	A l a r m characters	A l a r m sound	Conditions
Tracked target	 12		(Off)	(Off)	<ul style="list-style-type: none"> <li>• CPA&gt;CPA LIMIT</li> <li>• 0&gt;TCPA</li> <li>• TCPA&gt;TCPA LIMIT</li> </ul> The symbol is displayed when one of the above conditions is met.
Activated AIS target	 AIS12				
Dangerous target	 12 Red blinking		CPA/TCPA	Beep sound (pee-poh)  Alarm acknowledge	<ul style="list-style-type: none"> <li>• CPA ≤ CPA LIMIT</li> <li>• 0 ≤ TCPA ≤ TCPA LIMIT</li> </ul> An alarm is issued when all the conditions are met.  The AIS targets that issues alarm refer to Section 5.3.9
	 AIS12 Red blinking				

CPA Limit and TCPA Limit: The Setting Values

## 5.5.2 Alarm for New Target Acquired in Automatic Acquisition Zone (New Target)



# CAUTION





**In setting an automatic acquisition zone, it is necessary to adjust the gain, sea clutter suppression and rain / snow clutter suppression to ensure that target echoes are displayed in the optimum conditions. No automatic acquisition zone alarms will be issued for targets undetected**

The automatic acquisition function sets a zone in a range and issues an alarm when a new target (which is not yet acquired) goes into this zone.

For the setting of an automatic acquisition zone, refer to "Acquiring Target" in Section 5.2.1.1 "Automatic acquisition".

Alarm for New Target Acquired in Automatic Acquisition Zone

Status	Symbol display	on	A l a r m characters	Alarm sound	Conditions
New target in automatic acquisition zone	 Red Blinking		New Target	Beep sound (pipi-pipi)  Alarm acknowledge able	The alarm is issued when a new target is acquired in the automatic acquisition zone.



When an already acquired target goes into automatic acquisition zone, the alarm message is not displayed and the buzzer does not sound either.

## 5.5.3 Lost Target Alarm (Lost)

### Attention

- If the gain, sea clutter suppression, rain/snow clutter suppression are not adjusted adequately, the lost target alarm may be easily generated. So such adjustments should be mad carefully.**





When it is impossible to continue tracking any acquired and tracked target, or the data of AIS target cannot received for a specified time, the Lost Alarm will be generated. The typical causes for alarm generation are shown below, but not limited to the following:

- The target echo is very weak.
- The target is shadowed by a shore or a large ship and its echo is not received.
- The target echo is blurred by sea clutter returns.

If a target under tracking goes out of a range of 32 nm and can no longer be tracked, it is canceled without a lost target alarm.

Lost Target Alarm

Status	Symbol on display	Alarm characters	Alarm sound	Conditions
Lost Target	 Red Blinking	Lost	Beep sound (pee)  Alarm acknowledgeable	The alarm will sound once when a lost target symbol is displayed.
	 Red Blinking			

### 5.5.4 Gyro Set Alarm

The GYRO I/F in this system receives signals from a gyro. Even if the power is turned off, the system will follow up the gyro. However, the system stops the follow-up operation when the power of the master gyro is turned off or when any trouble occurs to the line. When the power of the master gyro is recovered, the Set Gyro alarm will be generated.

If this alarm occurs, set the gyro.

Gyro Set Alarm

Alarm characters	Alarm sound	Conditions
Set Gyro	Beep sound (pipi-pipi)	The signals from the gyro are stopped, but the gyro is recovered.

# 5.6 TRACK FUNCTION

## 5.6.1 Past Position (Past POSN)

### Procedures

- 1) **Left-click the past position display interval unit switching button in the Target Information located at the upper right of the display, and set a desired unit.**

The past position display interval unit will be set to  or .

- 2) **Left-click the past position display interval switching button in the Target Information located at the upper right of the display, and set a desired track display interval.**

The past position will be set.

: Tracks are not displayed.

Numeric : Tracks are displayed at intervals of a specified value.

The past position function can display up to ten past positions of a target under tracking. The past position display interval can be set to specified time intervals of 0.5, 1, 2, or 4 minutes, or specified range intervals of 0.1, 0.2, 0.5, or 1 nm.

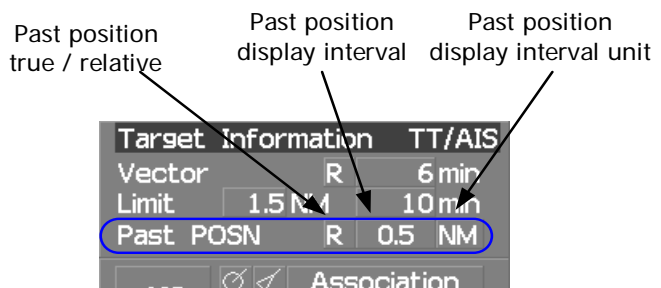

The specified interval is displayed in the past position display interval switching in Target Information located at the upper right of the display. When  is displayed, the track display function is turned off.

The track mode operates in conjunction with the vector mode, and a true or relative track is displayed. In relative vector mode, the relative tracks of the target are displayed. In true vector mode, true tracks that are calculated from the relative bearing, range, own ship's course, and speed are displayed.

The target is acquisition, past position of traced target is start plot. The AIS target is displayed, past position of AIS target is start plot.

If the past position plotted time is short, the indicated past position duration may not have achieved the specified time or range.

## 5.6.2 Target Ship's Tracks (Target Track)

This function makes settings for the tracks of tracked targets and AIS targets.

The system can display the tracks of up to 20 target ships.

The target track function is available between latitudes of 85° N and 85° S.

### 5.6.2.1 Track Color Setting (Target Track Color)

#### Procedures

- 1) **Put the cursor on the tracked target or activated AIS target, and right-click.**

The setting items for cursor modes will be displayed.

- 2) **Left-click** Property .

The Property will appear.

- 3) Left-click the item button of 2. Track Color .

The setting items for Track Color will be displayed.

- 4) **Left-click the button corresponding to the track color to be set.**

Colors set by performing the procedure in Section 5.6.2.3 "Setting of Target Ship's Track Colors (Target Track Color)" can be selected.

Individual colors can be set for up to 10 ships. The same color is set for 11 to 20 ships.

### 5.6.2.2 Target Ship's Track Function On/Off (Target Track Function)

#### Procedures

- 1) **Open the T.TRK menu by performing the following menu operation.**

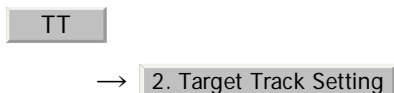

- 2) Left-click the item button of 1. Target Track Function .

The Target Track Function will be set to on or off.

On : Target Track Function is turned on.

Off : Target Track Function is turned off.



Note that when this function is turned off, all the other ship's track functions are turned off. In this case, the track data of other ships is not saved, so they cannot be traced later.

### 5.6.2.3 Setting of Target Ship's Track Colors (Target Track Color)

You can set either one track color for all targets under tracking, or individual colors for the ships of track numbers 1 to 10. The tracks of ships 11 to 20 are displayed in the same color.

 If the other ship's track function (Target Track Function) is turned off, the track data of other ships is not saved.

#### Procedures

- 1) **Open the Target Track Color menu by performing the following menu operation.**

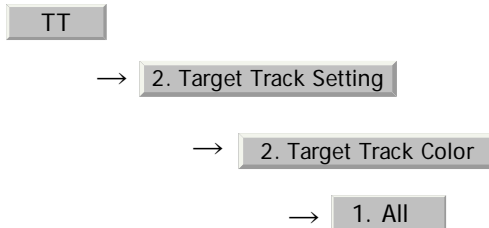

The setting items for All will be displayed.

- 2) **Left-click the button corresponding to the track display to be set.**

**Individual** : Track color is set individually for ships.  
 color name : One color is set for all ships.

#### Individual setting

- 3) **Left-click the button corresponding to the track number to be set.**

The setting items for the selected track number will be displayed.

- 4) **Left-click the button corresponding to the track color to be set.**

The track color of the selected track number will be set.

When **Individual** is selected, the track numbers **Target Track No.1** to **No.10** and the individual setting for **Other** are valid. Select a color for each target.

The color list is displayed by left-clicking the button corresponding to the item number to be set. Select a desired color. There are 8 color choices: **Off**, **White**, **Gray**, **Blue**, **Green**, **Yellow**, **Pink**, and **Red**.

**Target Track No.1** ~ **No.10** : Setting for 1 to 10 ships  
**Other** : Setting for 11 to 20 ships

 Note that the individual setting is not enabled unless **Individual** is selected.

### 5.6.2.4 Setting of Target Ship's Track Display (Target Track Display)

The target track display function can be turned on / off. Choices for track display are displaying / hiding the tracks of all ships and Individual (displaying the tracks of individual ships).

#### Procedures

- 1) **Open the Target Track Display menu by performing the following menu operation.**

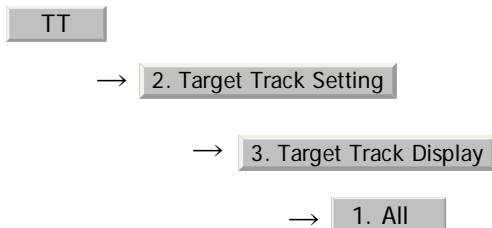

The setting items for All will be displayed.

- 2) **Left-click the button corresponding to the track display to be set.**

- : Track display is set for individual ships.
- : The tracks of all ships are hidden.
- : The tracks of all ships are displayed.



Even when Target Track Display is turned off, the track data of other ships is saved if Track Memory Interval is set.

#### Individual setting

- 3) **Left-click the button corresponding to the track number to be set.**

The selected track number display will be set to on or off.

- : The track number display is turned on.
- : The track number display is turned off.

When  is selected, the track numbers  to  and the individual setting for  are valid. Select on / off for each target.

- ~  : Setting for 1 to 10 ships
- : Setting for 11 to 20 ships



Note that the individual setting is not enabled unless Individual is selected.

### 5.6.2.5 Setting of Target Ship's Track Saving Interval (Track Memory Interval)

An interval for saving target ship's track data can be set.



This function is not available when the Target Track Function is turned off.

#### Procedures

- 1) **Open the Track Memory Interval menu by performing the following menu operation.**

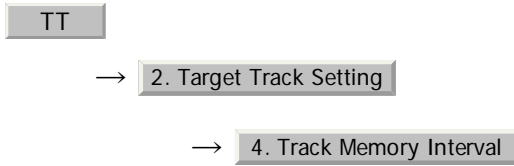

- 2) **Left-click the button corresponding to the interval to be set.**

Select an interval from the following:

- Off/
- 3sec/5sec/10sec/30sec/
- 1min/3min/5min/10min/30min/60min/
- 1NM/3NM/5NM/10NM

### 5.6.2.6 Clear of Target Ship's Track (Clear Track)

The target ship's track can be cleared by setting a color or a track number.



If Card T.TRK Display is used, target ship's tracks displayed through the card cannot be cleared.

#### [1] Clear of Tracks by Setting Color (Clear Track Color)

#### Procedures

- 1) **Open the Clear Track Color menu by performing the following menu operation.**



The setting items for Clear Track Color will be displayed.

- 2) **Left-click the button corresponding to the color of the target tracks to be cleared.**

The Confirmation Window will appear.

- 3) Left-click **1. Yes** to clear the track line.

All the tracks of the selected color will be cleared.

## [2] Clear of Tracks by Setting Track Number (Clear Track Number)

### Procedures

- 1) **Open the T.TRK menu by performing the following menu operation.**

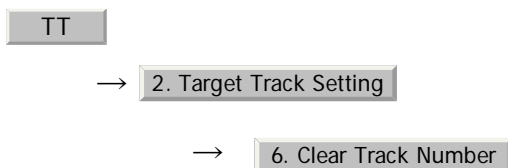

The setting items for Clear Track Number will be displayed.

- 2) **Left-click the button corresponding to the number of the tracks to be cleared.**

The Confirmation Window will appear.

- 3) **Left-click 1. Yes to clear the track line.**

The tracks of the selected number will be cleared.

### 5.6.2.7 Operation of Target Ship's Track Data Saved on Card (File Operations)

Target ship's track data can be saved on a flash memory card and read from the card.



Data can be saved to a flash memory card until the card becomes full, but the number of files that can be read and displayed is limited to 64 in alphanumeric order. When the number of files has reached 64, delete unnecessary files.

**[1] Loading File (Load)**

**Procedures**

- 1) **Insert a flash memory card into the card slot**

Flash memory card (option) is necessary.

- 2) **Open the File Operations menu by performing the following menu operation.**

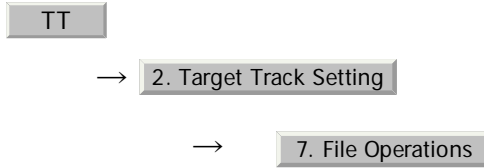

- 3) **Left-click the item button of 1. Select Card Slot** to select a card slot.

The setting item for Select Card Slot is switched between Slot1 and Slot2.

- 4) **Left-click the item button of 2. Load Mode** to select **Add or Overwrite**.

The setting item for Load Mode is switched between  and .

When  is selected, new data is added to the current data on the card. When  is selected, new data is saved over the current data on the card.

- 5) **Left-click 3. Load**.

Currently saved target ship's track data will be listed.

- 6) **Left-click the button corresponding to the file to be loaded.**

The Confirmation Window will appear.

- 7) **Left-click 1. Yes** to load the file.

The selected target track data will be loaded and shown on the radar display.



## [2] Saving File (Save)

### Procedures

- 1) **Insert a flash memory card into the card slot.**

Flash memory card (option) is necessary.

- 2) **Open the File Operations menu by performing the following menu operation.**

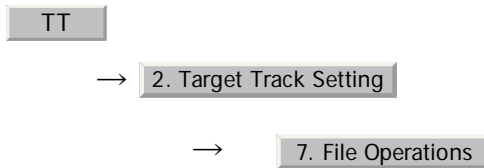

- 3) **Left-click the item button of 1. Select Card Slot to select a card slot.**

The setting item for Select Card Slot is switched between Slot1 and Slot2.

- 4) **Left-click 4. Save.**

The Input File Name menu will appear.

- 5) **Input the file name to be saved.**

Up to ten characters can be input as a file name.

For inputs to the characters input screen, refer to Section 3.3.4.7 "Entering a character". After the input, the Confirmation Window will appear.

- 6) **Left-click 1. Yes to save the file.**

The currently displayed target track data will be saved.

**[3] Erasing File (Erase)**

**Procedures**

- 1) **Insert the flash memory card into the card slot.**

Flash memory card (option) is necessary.

- 2) **Open the File Operations menu by performing the following menu operation.**

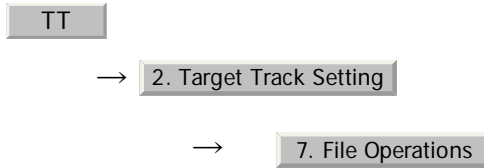

- 3) **Left-click the item button of 1. Select Card Slot to select a card slot.**

The setting item for Select Card Slot is switched between Slot1 and Slot2.

- 4) **Left-click 5. Erase.**

The Erase menu will appear.

Currently saved target ship's track data on the card will be listed.

- 5) **Left-click the button corresponding to the file to be erased.**

The Confirmation Window will appear.

- 6) **Left-click 1. Yes to erase the file.**

The selected target track data will be erased and the file name will disappear from the list.

## [4] Displaying File (Card Target Track Display)

### Procedures

- 1) **Insert the flash memory card into the card slot.**

Flash memory card (option) is necessary.

- 2) **Open the File Operations menu by performing the following menu operation.**

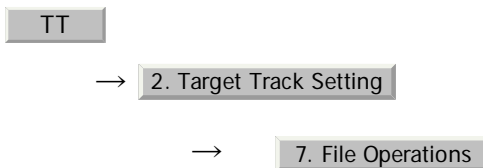

- 3) **Left-click the item button of 1. Select Card Slot to select a card slot.**

The setting item for Select Card Slot is switched between Slot1 and Slot2.

- 4) **Left-click 6. Card T.TRK Display .**

The Card T.TRK Display menu will appear.

Currently saved target ship's track data on the card will be listed.

- 5) **Left-click the button corresponding to the file to be displayed.**

The Confirmation Window will appear.

- 6) **Left-click 1. Yes to display the T.TRK line.**

The selected file will be highlighted, and the currently saved target track data will be displayed.

### Cancel

- 1) **Open the Card T.TRK Display window.**

The displayed file is highlighted.

- 2) **Left-click the button corresponding to the displayed file.**

The file will be deselected and returned to normal display.

# 5.7

## TRIAL MANEUVERING (Trial Maneuver)

### Attention

- Trial maneuvering is to simulate own ship's course and speed in the conditions that the course and speed of a target ship are unchanged as they are. As the situation is different from any actual ship maneuvering, set values with large margins to CPA Limit and TCPA Limit.

5

The trial maneuvering is the function of simulating own ship's course and speed for collision avoidance when a dangerous target appears. When the own ship's course and speed are entered in manual mode, the trial maneuvering function checks if pre-acquired or pre-activated targets are dangerous.

The ranges of course and speed to be entered manually:

Course: 360° (in 0.1° intervals) ..... [EBL] dial

Speed: 0 to 100kn (in 0.1kn step) ..... [VRM] dial

### 5.7.1 Trial Maneuvering in the True Vector Mode

In the True Vector mode, calculations are performed according to the values set by Trial Speed, Trial Course and other features, and the result is displayed as a bold-line that represents the change of own ship's vector as shown in the Fig 5-7 below (an example of the course changed to the right).

In this Fig 5-7, the dangerous target forward left becomes safe as a result of simulation.

The tracked target information indicates the current CPA and TCPA values regardless of the result of simulation.

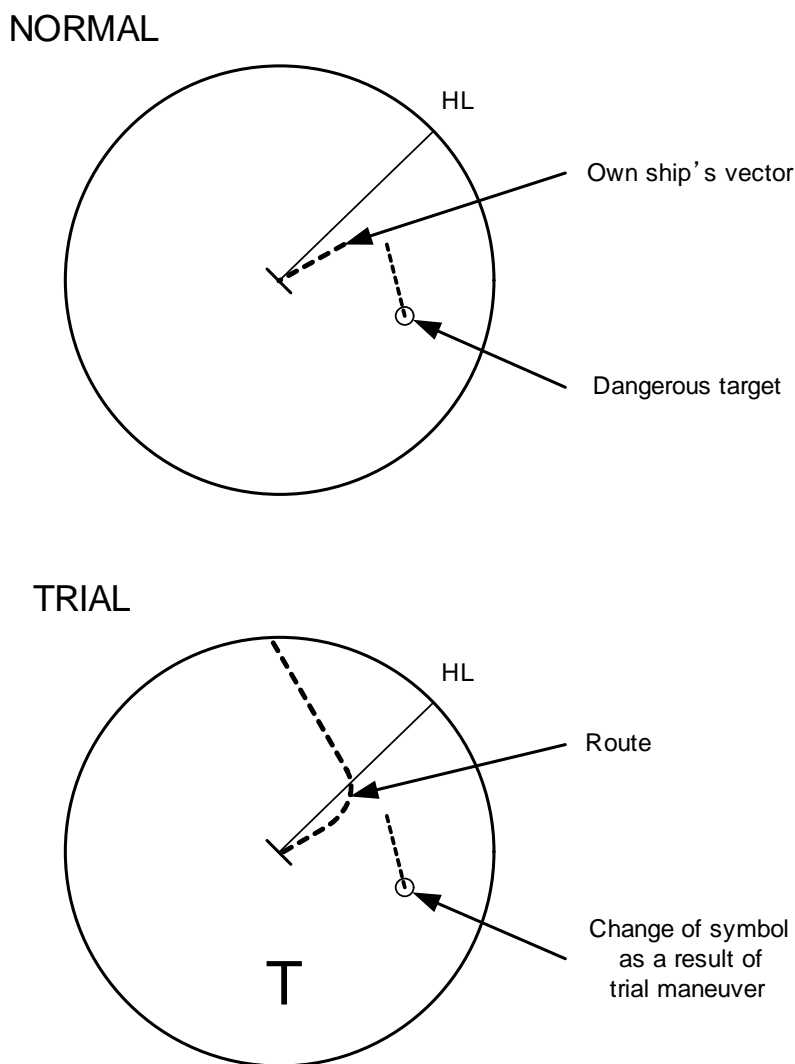
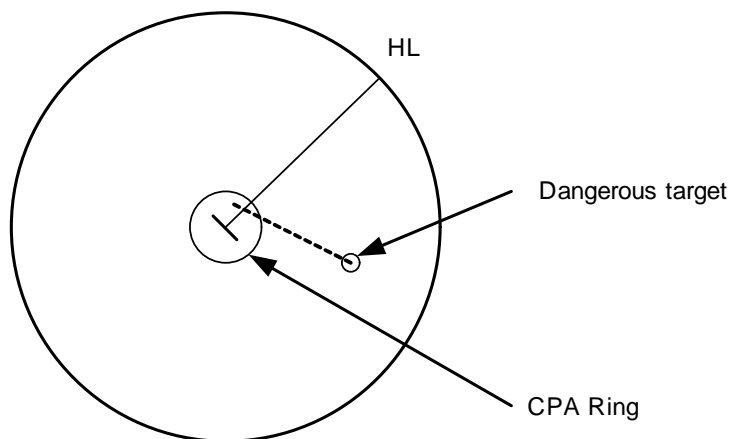

Fig 5-7: True Vector Mode

## 5.7.2 Trial Maneuvering in the Relative Vector Mode

The result of Trial maneuvering in the Relative Vector mode is shown by a change in target vector. In the Fig 5-8 below (in the same conditions as in the True Vector mode in the previous page), it is seen that the acquired target is a dangerous one because its vector is crossing the CPA RING.

### NORMAL



### TRIAL

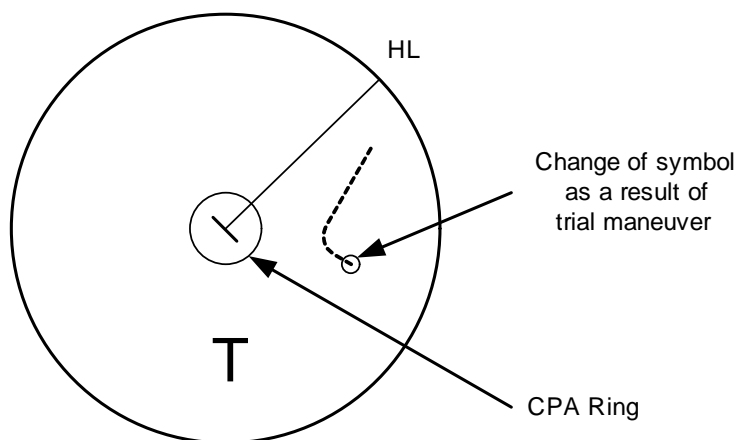

Fig 5-8: *Relative Vector Mode*

The above Fig 5-8 shows that the relative vector of the target has changed as shown in the figure as a result of simulation (course and speed), so that the symbol color is changed into “White”, a safe target.

Irrespective of the simulation results, the current CPA and TCPA values are shown in the tracked target information just like when the true vector mode is active.

The course change of own ship is displayed as a dotted-line.

Better information is provided by using relative motion and sea stabilization.

### 5.7.3 Operation of Trial Maneuvering Function

#### Procedures

- 1) **Open the Trial Maneuver menu by performing the following menu operation.**



- 2) **Left-click the item button of 1. Trial Function .**

The Trial Function will be set to on or off.

**On** : The trial maneuvering function is turned on.

**Off** : The trial maneuvering function is turned off.

When the Trial Function is active, the character " T " will display at the bottom of the radar display.

- 3) **Set values for Course by turning the [EBL] dial, and for Speed by turning the [VRM] dial.**

- 4) **Set other characteristics.**

**Vector Time** : Vector time (1 to 60 min)

**Time to Maneuver** : Time until trial maneuvering is started (0 to 30 min)

**Own Ship Dynamic Trait** : Dynamic trait of the own ship

→ **Reach** : Range from when steered to when the ship begins to turn (0 to 2000 m)

→ **Turn Radius** : Turning radius (0.10 to 2.00 nm)

→ **Acceleration** : Acceleration (0.0 to 100 knots/min)

→ **Deceleration** : Deceleration (0.0 to 100 knots/min)

For inputs to the value input screen, refer to Section 3.3.4.2 "Directly entering a numeric value".

Dangerous target symbols are displayed in red and safe target symbols in white.

 Vector Time is valid only when Trial Function is set to on. If it is off, the vector time before trial maneuvering is displayed.

Time until the start of trial maneuvering is counted down immediately after the input. The acceleration and deceleration are influenced depending on the relationship between the current speed and the input speed for trial maneuvering.

If 0.0 kn/min is set for Acceleration when the speed for trial maneuvering is faster than the current speed, or for Deceleration when the speed for trial maneuvering is slower than the current speed, the system performs simulation on the assumption that the speed is changed immediately after the time set for Time to Maneuver .

**Cancel**

- 1) **Open the Trial Maneuver menu by performing the following menu operation.**

TT



3. Trial Maneuver

- 2) **Left-click the item button of 1. Trial Function .**

The Trial Function will be set to on or off.

Off

: The Trial Function will be set to off.





# SECTION 6

## TRUE AND FALSE ECHOES ON DISPLAY

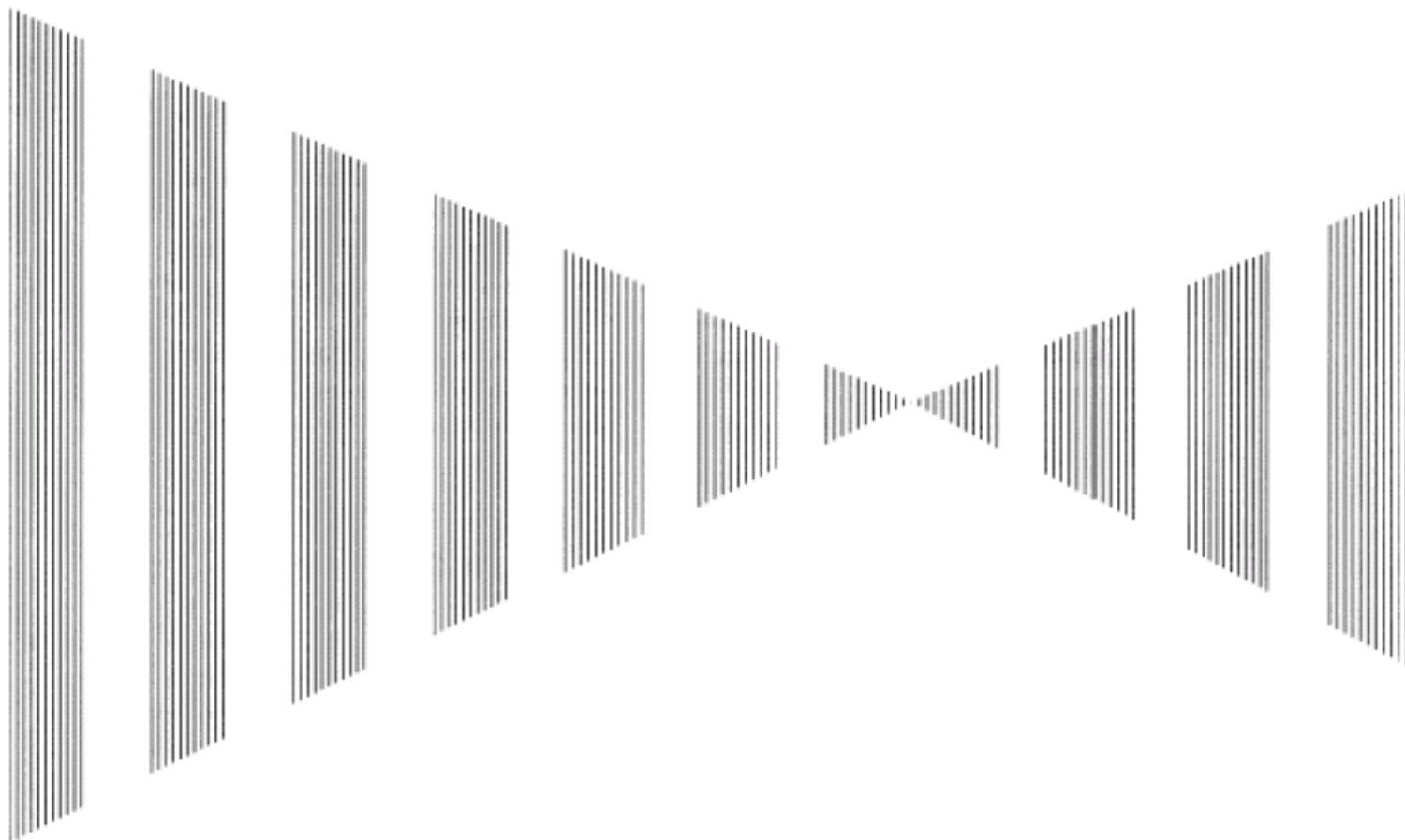

### TRUE AND FALSE ECHOES ON DISPLAY

6.1	RADAR WAVE WITH THE HORIZON .....	6-1
6.2	STRENGTH OF REFLECTION FROM THE TARGET .....	6-3
6.3	SEA CLUTTER AND RAIN AND SNOW CLUTTER .....	6-5
6.4	FALSE ECHOES .....	6-9



The radar operator has a role of interpreting the radar displays to provide his best aid in maneuvering the ship. For this purpose, the operator has to observe the radar displays after fully understanding the advantages and disadvantages that the radar has. For better interpretation of radar display, it is important to gain more experiences by operating the radar equipment in fair weathers and comparing the target ships watched with the naked eyes and their echoes on the radar display.

The radar is mainly used to monitor the courses of own ship and other ships in open seas, to check buoys and other nautical marks when entering a port, to measure own ship's position in the coastal waters relative to the bearings and ranges of the shore or islands using a chart, and to monitor the position and movement of a heavy rain if it appears on the radar display.

Various types of radar display will be explained below.

## 6.1 RADAR WAVE WITH THE HORIZON

Radar beam radiation has the nature of propagating nearly along the curved surface of the earth. The propagation varies with the property of the air layer through which the radar beam propagates. In the normal propagation, the distance (D) of the radar wave to the horizon is approximately 10% longer than the distance to the optical horizon. The distance (D) is given by the following formula:

$$D = 2.23(\sqrt{h_1} + \sqrt{h_2}) \text{ [NM]}$$

$h_1$ : Height (m) of radar scanner above sea level

$h_2$ : Height (m) of a target above sea level

Fig 6-2 is a diagram for determining the maximum detection range of a target that is limited by the curve of the earth surface in the normal propagation.

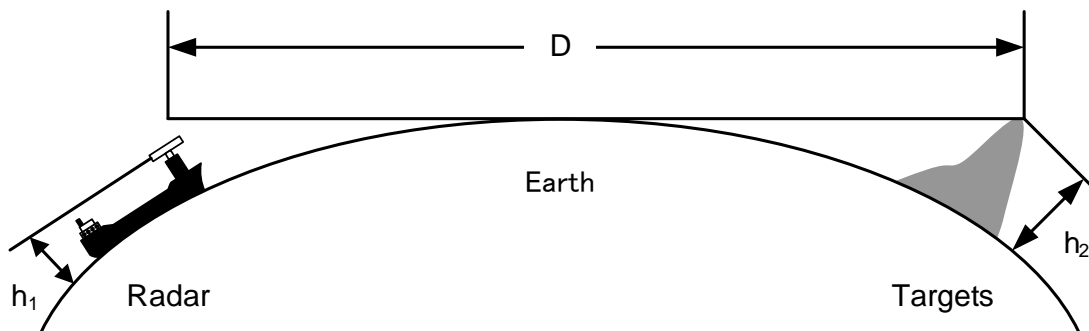

Fig 6-1: RADAR wave with the horizon

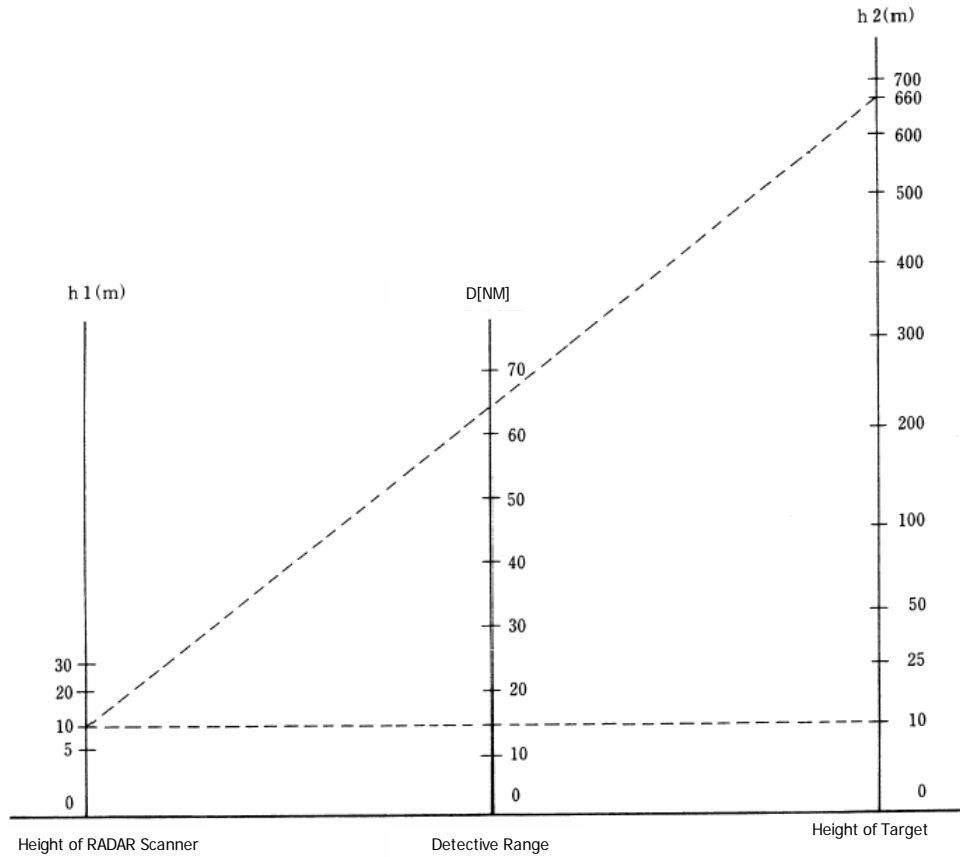

Fig 6-2: Maximum detection range of a target

When the height of own ship's scanner is 10 m for instance,

- i. A target that can be detected at the radar range of 64 nm on the radar display is required to have a height of 660 m or more.
- ii. If the height of a target is 10 m, the radar range has to be approx. 15 nm. However, the maximum radar range at which a target can be detected on the radar display depends upon the size of the target and the weather conditions, that is, the radar range may increase or decrease depending upon those conditions.

## 6.2 STRENGTH OF REFLECTION FROM THE TARGET

The signal intensity reflected from a target depends not only on the height and size of the target but also on its material and shape. The echo intensity from a higher and larger target is not always higher in general.

In particular, the echo from a coast line is affected by the geographic conditions of the coast. If the coast has a very gentle slope, the echo from a mountain of the inland appears on the radar display.(Fig 6-3) Therefore, the distance to the coast line should be measured carefully.

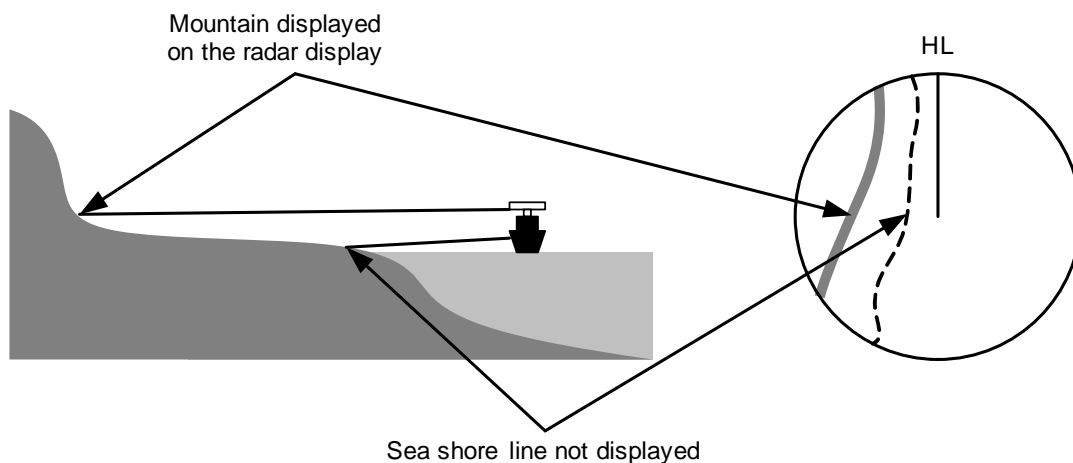

Fig 6-3: Sea shore line which is not displayed

Table 6-1 shows the graph indicating the relation between the target detection distance and the radar reflection cross-sectional area (RCS) with regard to the type and the height of the target in a situation in which the weather is good, the sea state is calm and the radio wave propagation is normal. As revealed by this table, even on the same sea shore line, detection distance greatly differs depending on the height of the target from the surface of the sea. Furthermore, because the target detection distance is greatly influenced by the shape and material of the target and environmental conditions, such as the sea state, weather, and radio wave propagation, caution should be taken when detecting distance of target.

Table 6-1 : Relation between type and height of target and detection distance and RCS

Type of target	Height from sea surface (m)	Detection distance (NM)		RCS [ $m_2$ ]	
		X band	S band	X band	S band
Sea shore line	60	20	20	50,000	50,000
Sea shore line	6	8	8	5000	5000
Sea shore line	3	6	6	2500	2500
SOLAS target ship (>5000GT)	10	11	11	50,000	30,000
SOLAS target ship (>500GT)	5	8	8	1800	1000
Small boat with IMO standard compatible radar reflector	4	5.0	3.7	7,5	0,5
Marine buoy with corner reflector	3,5	4.9	3.6	10	1
Standard marine buoy	3,5	4.6	3.0	5	0,5
10-meter small boat without radar reflector	2	3.4	3.0	2,5	1,4
Waterway location beacon	1	2.0	1.0	1	0,1



Detection distance shown in the above table may greatly decrease depending on the shape of the target, sea state, weather and radio wave propagation conditions.

# 6.3

## SEA CLUTTER AND RAIN AND SNOW CLUTTER

In addition to the echo required for observing ships and land, radar video image also includes unnecessary echo, such as reflection from waves on the sea surface and reflection from rain and snow. Reflection from the sea surface is called "sea clutter," and reflection from rain and snow is called "rain and snow clutter," and those spurious waves must be eliminated by the clutter rejection function.

### a. Sea clutter

Sea clutter appears as an image radiating outwardly from the center of the radar display and changing depending on the size and the shape of waves. Generally, as waves become larger, image level of the sea clutter is intensified and the clutter far away is also displayed. When waves are large and the sea clutter level is high, it is difficult to distinguish sea clutter from a small boat whose reflection intensity is weak. Accordingly, it is necessary to properly adjust the sea clutter rejection function. Table 6-2 shows the relation between the sea state (SS) showing the size of waves generated by wind and the radar's detection probability.

Table 6-2 : Sea state and probability of target detection

S band radar (probability to detect a target at a distance of 0.4 NM)				
RCS	SS1 ~ 2	SS2 ~ 3	SS3 ~ 4	SS4 ~ 5
0.1m2	V <sup>i</sup>	V-M <sup>ii</sup>	M-NV <sup>iii</sup>	
0.5 m2	V	V	V-M	M-NV
1 m2	V	V	V	V-M

X band radar (probability to detect a target at a distance of 0.7 NM)				
RCS	SS1 ~ 2	SS2 ~ 3	SS3 ~ 4	SS4 ~ 5
1m2	V-M	M-NV		
5 m2	V	V-M	M-NV	
10 m2	V	V	V	V-M

- i. V: Detection probability of 80%
- ii. M: Detection probability of 50%
- iii. NV: Detection probability of less than 50%





As shown in Table 6-2, the number of SS increases as the wind speed becomes high and the waves become large. Table 6.2 reveals that detection probability decreases from V (80 %) to NV (less than 50 %) as the number of SS increases. Therefore, even if the sea state is calm and a target clearly appears on the radar display, when the sea state becomes rough, target detection probability decreases resulting in difficulty of target detection by the radar.

Table 6-3 : Relation between Douglas sea state and average wind speed and significant wave height

Sea state	Average wind speed (kn)	Significant wave height (m) <sup>i</sup>
0	<4	<0,2
1	5-7	0,6
2	7-11	0,9
3	12-16	1,2
4	17-19	2,0
5	20-25	3,0
6	26-33	4,0

i. Significant wave height: an average of top N/3 higher waves when the number of waves detected within a constant time duration is N

For example, in the case of a standard marine buoy, RCS of X band radar is 5 m<sup>2</sup> as shown in Table 6-1. When observing such a target in the sea state (SS3) in which significant wave height exceeds 1.2 meters, detection probability is M-NV, as shown in Table 6-2, which indicates 50 % or less.

#### b. Rain and snow clutter

Rain and snow clutter is a video image that appears in a location where rain or snow is falling. The image changes according to the amount of rain (or the amount of snowfall). As precipitation increases, the image of rain and snow clutter becomes intensified on the radar display, and in the case of localized heavy rain, an image similar to the image indicating land is displayed in some cases. Furthermore, because radio waves tend to attenuate due to rain and snow, the ability to detect a target in the rain and snow clutter or a target beyond the rain and snow clutter may decrease. The amount of attenuation depends on the transmission frequency, antenna beam width, and the pulse length. Fig 6-4 and Fig 6-5 show examples in which detection distance is reduced due to the influence of precipitation. Because of this, a target, which clearly appeared up to 10 NM by an X band radar (pulse width of 0.8μs) when it was not raining, may become dimly visible up to 5 NM when the amount of rain becomes 4 millimeters per hour. Furthermore, when comparing the X band radar with the S band radar, target detection distance decreases less when the S band radar is used, which means it is influenced less by precipitation.

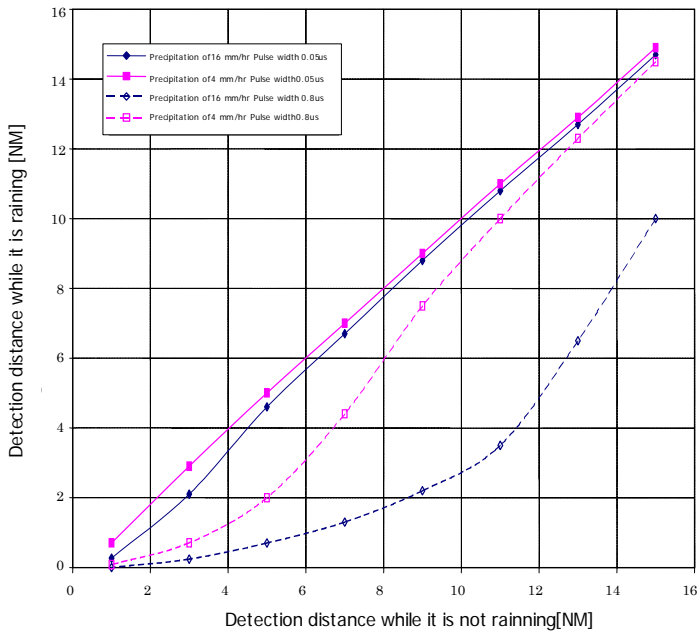

Fig 6-4: Decreased target detection distance by S band radar due to precipitation

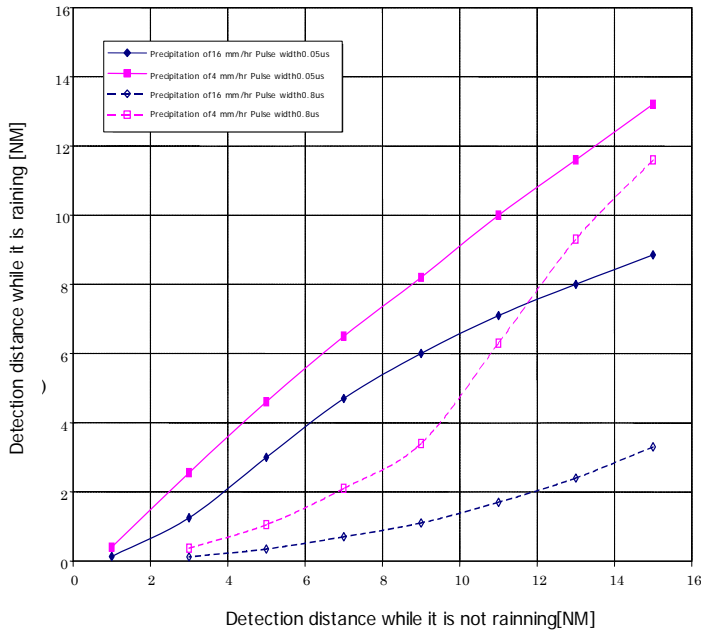

Fig 6-5: Decreased target detection distance by X band radar due to precipitation

### c. Coping with sea clutter and rain and snow clutter

When the weather is bad and the ocean is rough, the use of the S band radar is effective because the radar is not influenced by sea clutter so much and attenuation due to rain drops is small. When an X band radar is used, reducing the pulse width will reduce the influence by spurious waves, and also the spurious wave rejection function effectively works; therefore, the use of short pulse is effective when the weather is bad. By using image processing functions PROC1 1 to 3, it is expected that spurious waves are further suppressed. Since optimal settings for those items can be automatically made by using the function mode, it is recommended that STORM or RAIN be used by selecting the function mode when the weather is bad. For details of the function mode, see Section 3.9 "USE FUNCTION KEY [USER]".

However, these functions may make some targets invisible, particularly targets with higher speeds.

## 6.4 FALSE ECHOES

The radar observer may be embarrassed with some echoes that do not exist actually. These false echoes appear by the following causes that are well known:

### a. Shadow

When the radar scanner is installed near a funnel or mast, the echo of a target that exists in the direction of the funnel or mast cannot appear on the radar display because the radar beam is reflected on the funnel or mast. Whether there are some false echoes due to shadows can be checked monitoring the sea clutter returns, in which there may be a part of weak or no returns.

Such shadows appear always in the same directions, which the operator should have in mind in radar operation.

### b. Side Lobe Effect

A broken-line circular arc may appear at the same range as the main lobe of the radar beam on the radar display. This type of false echo can easily be discriminated when a target echo appears isolated. (see Fig 6-6)

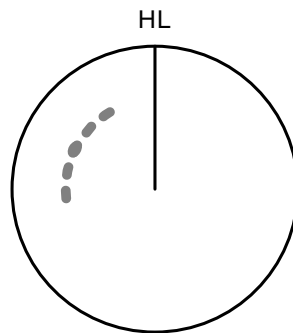

Fig 6-6: *False echo*

**c. False Echo by Secondary Reflection**

When a target exists near own ship, two echoes from the single target may appear on the radar display.

One of those echoes is the direct echo return from the target and the other is the secondary reflection return from a mast or funnel that stands in the same direction as shown in Fig 6-7.

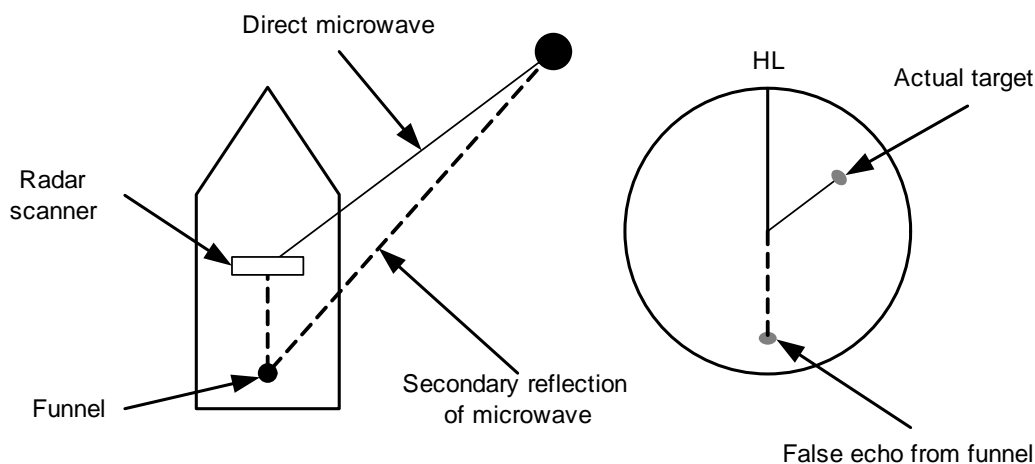

Fig 6-7: False echo by secondary reflection

**d. False Echo by Multiple Reflection**

When there is a large structure or ship with a high vertical surface near own ship as shown in Fig 6-8, multiple reflection returns may appear on the radar display. These echoes appear in the same intervals, of which the nearest echo is the true echo of the target.

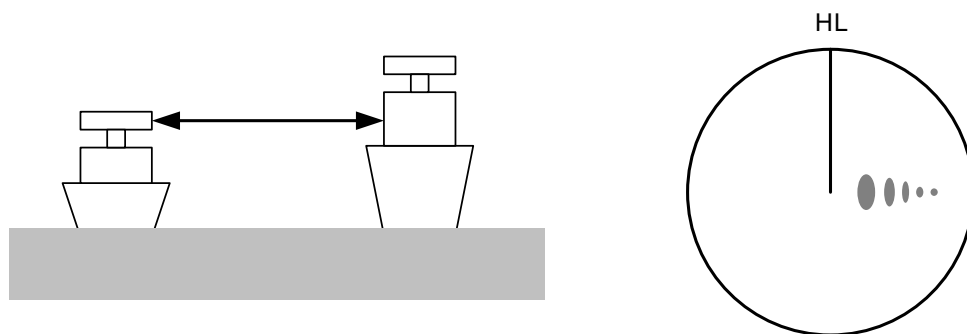

Fig 6-8: False echo by multiple reflection

**e. Second Time Echoes**

The maximum radar detection range depends upon the height of the scanner and the height of a target as described in the Section 6.1 "RADAR WAVE WITH THE HORIZON". If a so-called "duct" occurs on the sea surface due to a certain weather condition, however, the radar beam may propagate to a abnormally long distance, at which a target may be detected by the radar.

For instance, assuming that the pulse length is MP2 (on the repetition frequency of 2280 Hz), the first pulse is reflected from a target at about 35.5 NM or more and received during the next pulse repetition time. In this case, a false echo (second time echo) appears at a position that is about 35.5 NM shorter than the actual distance. If the false echo appears at 5 NM on the radar display, the true distance of the target is  $5+35.5=40.5$  NM. On the pulse length is LP1 (on the repetition frequency of 1280 Hz), a false echo may appear at a position that is about 63 NM shorter than the actual distance.

This type of false echo can be discriminated by changing over the range scale (the repetition frequency), because the distance of the target changes accordingly.

If second time echo is appeared, the use of Economy mode in PRF menu is effective. Otherwise, Stagger Trigger menu set to on. (See Section 3.8.3 "Set Scanner Unit (TXRX Setting)").

#### f. Radar Interference

When another radar equipment using the same frequency band as that on own ship is near own ship, a radar interference pattern may appear on the radar display. This interference pattern consists of a number of spots which appear in various forms. In many cases, these spots do not always appear at the same places, so that they can be discriminated from the target echoes. (See Fig 6-9)

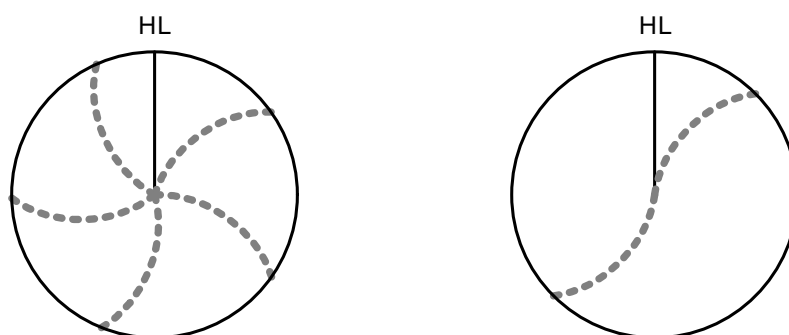

Fig 6-9: Radar interference

If radar equipment causing an interference pattern and this radar are of the same model, their transmitting repetition frequency is nearly the same. As a result, interference patterns may be displayed concentrically.

In this case, the interference patterns cannot be eliminated by using only the interference reflector function, so in-tune the transmitting repetition frequency. (See Section 3.8.3 "Set Scanner Unit (TXRX Setting)")

An interference suppressing effect can be heightened by applying a different transmitting repetition frequency to the interference pattern source radar and this radar.



# SECTION 7

## SETTINGS FOR SYSTEM OPERATION

### SETTINGS FOR SYSTEM OPERATION

7.1	SETTINGS AT INSTALLATION .....	7-1
7.1.1	How to Open the Serviceman Menu (Service Man Menu) .....	7-1
7.1.2	GYRO I/F Setting .....	7-2
7.1.3	Tuning (Tune Adjustment) .....	7-5
7.1.4	Bearing Adjustment .....	7-5
7.1.5	Range Adjustment .....	7-5
7.1.6	Navigator Setting (Device) .....	7-6
7.1.7	Setting of True Bearing Value .....	7-7
7.1.8	Antenna Height Setting (Antenna Height) .....	7-7
7.1.9	Setting of CCRP (CCRP Setting) .....	7-8
7.2	SETTINGS .....	7-11
7.2.1	Communication Port Setting (COM Port Setting) .....	7-11
7.2.2	Sector Blank Setting (Sector Blank) .....	7-15
7.2.3	Setting of Bearing Pulses from Scanner Unit (Output Pulse) ...	7-16
7.2.4	Slave Mode Setting (Master/Slave) .....	7-16
7.2.5	Language Setting (Language) .....	7-17
7.2.6	Date Time Setting .....	7-18



7.2.7	Input Installation Information .....	7-19
7.2.8	Setting the Alarm System .....	7-19
7.3	ADJUSTMENT .....	7-24
7.3.1	Noise Level Adjustment (Noise Level) .....	7-24
7.3.2	Adjustment of Target Tracking Function (TT) .....	7-25
7.3.3	Main Bang Suppression Level Adjustment (MBS) .....	7-27
7.3.4	Adjustment of Performance Monitor .....	7-29
7.4	MAINTENANCE MENU .....	7-31
7.4.1	Antenna Safety Switch (Safety Switch) .....	7-31
7.4.2	Initialization of Memory Area(Area Initial) .....	7-32
7.4.3	Save of Internal Memory Data (Card1/2) .....	7-33
7.4.4	Restoration of Scanner Unit Operation Time (TXRX Time) .....	7-34
7.4.5	Update of Character String Data (String Data Update) .....	7-36

# 7.1 SETTINGS AT INSTALLATION

This section describes the electrical adjustment procedures to be performed by service engineers during system installation.

The bearing adjustment value is saved to non-volatile memory in the scanner. Other settings are saved to non-volatile memory in the radar process unit.



## CAUTION



- Do not carry out the adjustments of the equipment except authorized service persons. If wrong setting is carried out, this may cause unstable operation.
- Do not carry out the adjustments during navigation. Otherwise, the radar performance may be affected, resulting in an accident or trouble.

## 7.1.1 How to Open the Serviceman Menu (Service Man Menu)

### Procedures

- 1) Hold down the **Main** button at the lower right of the display together with the left key.

The Code Input menu will appear.

- 2) Left-click the **0** button.

- 3) Left-click the **ENT** button.

The Serviceman Menu will appear.



Fig 7-1: Code Input

## 7.1.2 GYRO I/F Setting

### a. Gyro Settings (STEP or SYNC)

The GYRO I/F circuit of the system is designed to be compatible with most types of gyro compasses by simply setting the switches.

Step motor type: DC24V to DC100V

Synchro-motor type: Primary excitation voltage 50 to 115 VAC

Before power-on operation can be performed, the switches S1, S2, S5, S6, S7 and jumper TB105 on the gyro interface circuit (PC4201) must be set in accordance with the type of your gyro compass by performing the procedure below.

The switches are factory-set for a gyration ratio of 180X and the step motor type. Make sure of the type of the gyro compass installed on the own ship before starting the procedure below.

### Procedures

#### 1) Set S5 to "OFF".

The gyro compass and GYRO I/F are cut off.

#### 2) Set S6 and S7 in accordance with the type of your gyro compass.

There are two types of gyro compasses: one type outputs a step signal, and the other type outputs a synchro signal. Make sure of the type of the gyro compass installed on the own ship before setting the switches S6 and S7.

Synchro signal: Set the switches to [SYNC].

Step signal: Set the switches to [STEP].

#### 3) Set the DIP switch S1 in accordance with the type of the compass.

The items to be set are listed below. For the settings, refer to Table 7-1 : Gyro and Log Select Switches (S1 DIP Switch).

S1-1: Type of gyro signal (step/synchro)

S1-2/3: Gyration ratio of gyro compass

S1-4: Gyration direction of gyro compass

S1-5: Type of log signal (pulse/synchro)

S1-7/8: Ratio of log signal

4) **Set the DIP switch S2.**

The items to be set are listed below. For the setting, refer to Table 7-2: Gyro and Log Select Switches (S2 DIP Switch).

1	2	3	4	5	6	7	8
ON	OFF	OFF	OFF	ON	OFF	ON	OFF

5) **Confirm the settings of the DIP switch S10.**

The DIP switch must be set as shown below. Do not change any of the settings.

1	2	3	4	5	6	7	8
OFF	OFF	OFF	OFF	OFF	OFF	OFF	OFF

6) **Set the jumper TB105.**

The TB105 is set for using a low-voltage step signal.

1-2 connected: Setting for normal use

2-3 connected: Setting for a step signal of 22 V or less

7) **Connect the gyro signal and log signal cables to the terminal block.**

8) **Set S5 to "ON".**

The gyro compass and GYRO I/F are connected.

9) **After power-on operation, make sure of the radar video and the operation with the true bearing value.**

See the Section 7.1.7 "Setting of True Bearing Value".

10) **If the true bearing value of the radar equipment is reversed, change the setting of the switch S1-4.**

Table 7-1 : Gyro and Log Select Switches (S1 DIP Switch)

		1	2	3	4	5	6	7	8	
GYRO SIG	STEP	ON								
	SYNC	OFF								
	360X			OFF	OFF					
	180X			ON	OFF					
	90X			OFF	ON					
	36X			ON	ON					
	DIRECTION			REV		ON				
			NOR		OFF					
LOG SIG	TYPE	SYNC				ON				
		PULSE				OFF				
	PULSE / NM	Don't care						OFF		
		100P / 30X							ON	ON
		200P / 90X							OFF	ON
		400P / 180X							ON	OFF
		800P / 360X							OFF	OFF

Table 7-2 : Gyro and Log Select Switches (S2 DIP Switch)

S2 SETTING TABLE		1	2	3	4	5	6	7	8
OTHER SETTING	LOG ALARM	ON							
		OFF							
	GYRO SIMULATOR	ON							
		OFF							
	LOG SIMULATOR	ON							
		OFF							
	N.A.	Don't care			any				
	GYRO ALARM TIME	5s				ON			
		0.2s				OFF			
	HEADING SENSOR SOURCE	NMEA(HDT/THS)			ON				
		GYRO SIGNAL			OFF				
	NMEA BAUDRATE SETTING	4800				OFF	OFF		
		9600				ON	OFF		
		19200				OFF	ON		
38400				ON	ON				

### 7.1.3 Tuning (Tune Adjustment)

JMA-9172-SA radar is fully automatic. There is no necessary for a tuning function.

### 7.1.4 Bearing Adjustment

Make adjustment so that the bearing of the target measured with the ship's compass matches the bearing of the target echo on the radar display.

#### Procedures

- 1) Select **H Up** for the bearing presentation. Set video processing (PROC) to **PROC Off**.
- 2) Measure the bearing of an adequate target (e.g., a ship at anchor, a breakwater, or a buoy) relative to own ship's heading.
- 3) Open the Serviceman Menu.
- 4) Perform the following menu open procedure to open the Bearing Adjustment menu.

1. Adjust Menu

→ 2. Bearing Adjustment

For inputs to the value input screen, refer to Section 3.3.4.3 "Increasing or decreasing a numeric value".

Make adjustment by the 0.1°.

- 5) Adjust the bearing adjustment value by operating the **+** / **-** button so that the target measured in step 2) is adjusted to the correct bearing.
- 6) Left-click the **ENT** button to determine the value.

### 7.1.5 Range Adjustment

Make adjustment so that the range of a target on the radar display is shown correctly.

#### Procedures

- 1) Search the radar display for a target of which range is already known.

- 2) **Open the Serviceman Menu.**
- 3) **Perform the following menu open procedure to open the Range Adjustment menu.**

1. Adjust Menu

→

3. Range Adjustment

For inputs to the value input screen, refer to Section 3.3.4.3 "Increasing or decreasing a numeric value".

- 4) **Adjust the range adjustment value by operating the  /  button so that the target measured in step 1) falls in the correct range.**
- 5) **Left-click the  button to determine the value.**

## 7.1.6 Navigator Setting (Device)

Determine whether to connect navigators to the radar equipment.

Only the navigators set to ON here can be used.

### Procedures

- 1) **Open the Serviceman Menu.**
- 2) **Perform the following menu open procedure to open the Device Installation menu.**

2. Installation Menu

→

9. Next

→

3. Device Installation

- 3) **Select  for navigators connected to the radar equipment, and  for navigators not connected.**

Gyro : Gyro (via GYRO I/F)

Compass : Compass (Compliant with IEC61162)

GPS Compass : GPS Compass (JRC)

LOG : Log (via GYRO I/F)

2AXW : 2-axis log (Speed over water: Compliant with IEC61162)

2AXG : 2-axis log (Speed over ground: Compliant with IEC61162)

GPS : GPS (Compliant with IEC61162)

### 7.1.7 Setting of True Bearing Value

If GYRO I/F is used to input a gyro signal, the true bearing value indicated by the master gyro does not match the value indicated by the radar equipment only in a rare case. In this case, perform the following procedure to adjust the true bearing value of the radar equipment to the value of the master gyro.

#### Procedures

- 1) **Perform the following menu open procedure to open the true bearing value setting menu.**

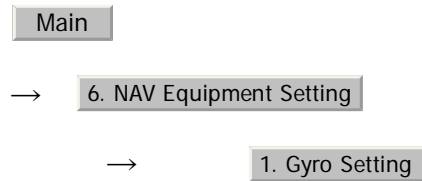

- 2) **Input the master gyro value to the value input screen.**

For inputs to the value input screen, refer to Section 3.3.4.3 "Increasing or decreasing a numeric value".

### 7.1.8 Antenna Height Setting (Antenna Height)

Set the height of radar antenna above sea level. Do not change this setting carelessly.

#### Procedures

- 1) **Measure the height of radar antenna above sea level in advance.**
- 2) **Open the Serviceman Menu.**
- 3) **Perform the following menu open procedure to open the Antenna Height setting menu.**

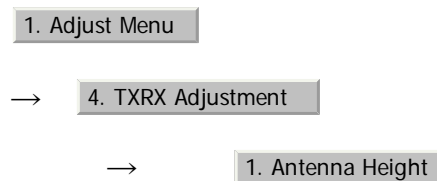

The Antenna Height menu will open.



- 4) **Select the setting that matches the antenna height measured in step 1).**

### 7.1.9 Setting of CCRP (CCRP Setting)

Set the own ship's CCRP location, radar antenna installation location, and GPS installation location.

CCRP : Up to four locations can be input. (One location selected when used)

Radar antenna: Up to eight radar antennas can be input. (Automatically selected in response to ISW operation)

GPS : Up to four locations can be input. (One location selected when used)

#### Procedures

- 1) **Measure the CCRP location, radar antenna location, and GPS antenna location in advance.**
- 2) **Open the Serviceman Menu.**
- 3) **Perform the following menu open procedure to open the CCRP Setting menu.**

2. Installation Menu

→ 4. CCRP Setting

- 4) **Specify the ship length for Length at the upper right of the CCRP Setting Menu, and the ship width for Beam.**
- 5) **Move the cursor onto the CCRP1 X, Y value, and left-click to input the CCRP1 location.**

When  $X > 0$ , the CCRP is on the starboard side of the ship.

When  $X < 0$ , it is on the port side.

- 6) **To input the second CCRP, click the CCRP2 button to display the CCRP2 X,Y value, and input the value in the same manner for step 5).**

Similarly, input the third and subsequent CCRPs.

- 7) **Repeat the above steps to input the GPS location(s) and radar antenna location(s).**

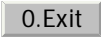
- 8) **If multiple CCRP locations and GPS locations are input, select the CCRP location and GPS location to be used by pressing the buttons at the upper left of the menu.**
- 9) **Click the  to close the CCRP Setting menu.**

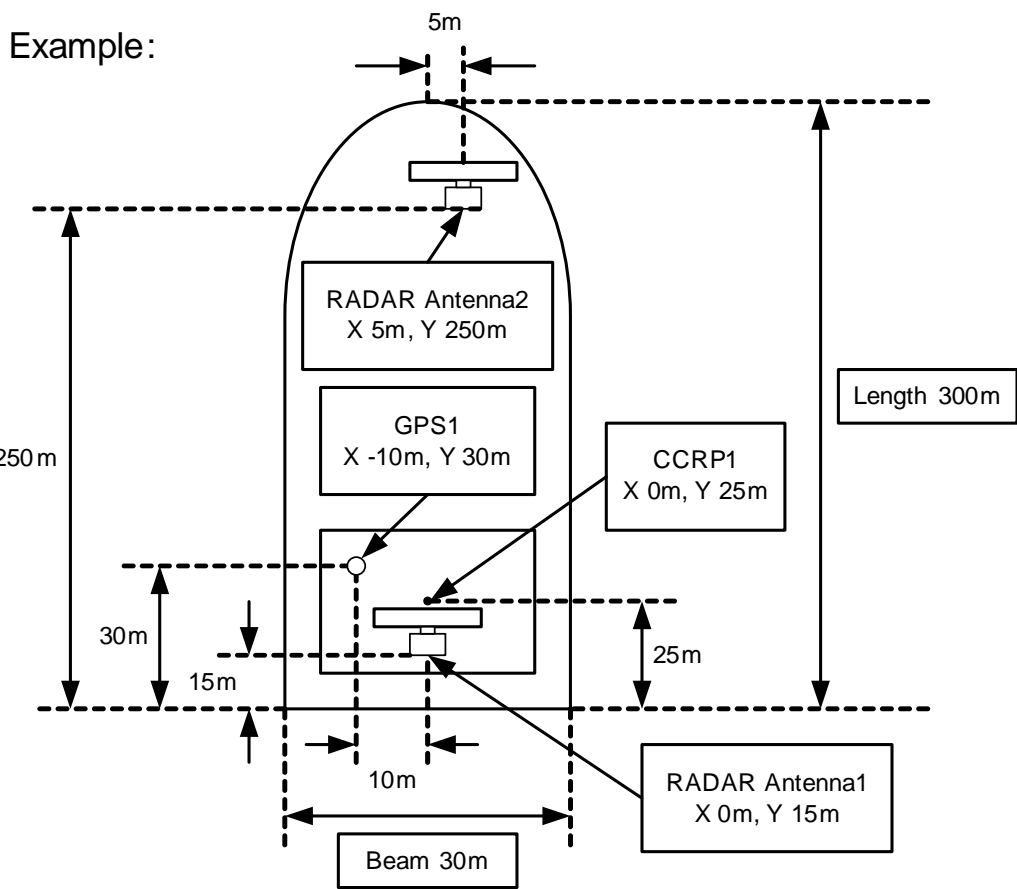

CCRP Settings

1. Select CCRP

2. Select GPS

Length

Beam

	X	Y
GPS1	-10.0	30.0 m
GPS2		m
GPS3		m
GPS4		m

	X	Y
RADAR Antenna1	0.0	15.0 m
RADAR Antenna2	5.0	250.0 m
RADAR Antenna3		m
RADAR Antenna4		m
RADAR Antenna5		m
RADAR Antenna6		m
RADAR Antenna7		m
RADAR Antenna8		m

	X	Y
CCRP1	0.0	25.0 m
CCRP2		m
CCRP3		m
CCRP4		m

0.

Y[m]

X[m]

(0,0)

- GPS
- RADAR Antenna
- CCRP

## 7.2 SETTINGS

This section describes the electrical adjustment procedures to be performed by service engineers during system installation.



### CAUTION



- Do not carry out the adjustments of the equipment except authorized service persons. If wrong setting is carried out, this may cause unstable operation.
- Do not carry out the adjustments during navigation. Otherwise, the radar performance may be affected, resulting in an accident or trouble.

### 7.2.1 Communication Port Setting (COM Port Setting)

External sensor signals are input to the radar equipment through a communication port. The radar equipment has ten communication ports. For signals to be input from sensors or to be output to the sensors, communication ports need to be set in accordance with the sensors.

#### 7.2.1.1 Baud Rate Setting (Baud Rate)

Set the baud rate of the signal to be input to the COM port.

##### Procedures

- 1) Open the Serviceman Menu.
- 2) Perform the following menu open procedure to open the Baud Rate setting menu.

2. Installation Menu

→ 5. COM Port Setting

→ 1. Baud Rate

3) **Set the baud rate of the port to be set.**

1. COMPASS <sup>i</sup> :	4800(NMEA)/9600(NSK)/ <b>38400(fast NMEA)</b> <sup>ii</sup> bps
2. MAINTENANCE/LOG :	1200/ <b>4800</b> /9600/38400 bps
3. NAV1 :	1200/ <b>4800</b> /9600/38400 bps
4. NAV2 :	1200/ <b>4800</b> /9600/38400 bps
5. ALARM :	1200/ <b>4800</b> /9600/38400 bps
6. JARPA <sup>iii</sup> :	1200/ <b>4800</b> /9600/38400 bps
7. AIS :	1200/4800/9600/ <b>38400</b> bps
8. ARPA <sup>iv</sup> :	1200/ <b>4800</b> /9600/38400 bps
9. COM <sup>v</sup> :	1200/ <b>4800</b> /9600/38400/115200 bps

- i. The compass port is a receive-only port that is dedicated to COMPASS signals.
- ii. The bold values are factory-set.
- iii. The JARPA port is a transmit-only port that is dedicated to JRC ARPA signals.
- iv. The ARPA port is a transmit-only port.
- v. The COM port connector is D-sub 9pin.

**7.2.1.2 Reception Port Setting(RX Port)**

Set the numbers of ports for receiving signals from sensors.

There are two methods for receiving signals: specifying a port for each sensor, or using the automatic recognition function without specifying ports.

**Procedures**

- 1) **Open the Serviceman Menu.**
- 2) **Perform the following menu open procedure to open the RX Port setting menu.**

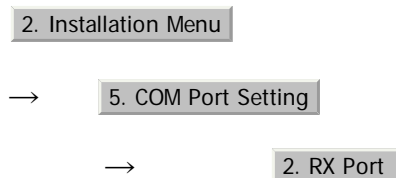

- 3) **Set a port for each sensor.**

Settable sensor signals	<b>GPS、DLOG、Alarm、Depth、Temperature、Wind、Current、ROT、RSA</b>
Selectable ports	When the automatic recognition function is used: <b>AUTO</b>
	When ports are specified: <b>LOG、NAV1、NAV2、ALARM、COM</b>

### 7.2.1.3 Reception Sentence Setting (RX Sentence)

Set signal sentences to be received from sensors.

The system is factory-set for using all sentences. To receive only specified sentences, select **No Use** for sentences which are not necessary.

#### Procedures

- 1) **Open the Serviceman Menu.**
- 2) **Perform the following menu open procedure to open the RX Sentence setting menu.**

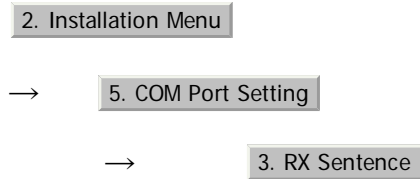

- 3) **Select the sentences to be used by the sensors to be set.**

Selection value: **Use** or **No Use** can be set for each sentence.

1. GPS(LL/COG/SOG) :	GGA/RMC/RMA/GNS/GLL/VTG
2. GPS(WPT/Time) :	GGA/RMC/RMB/BWC/BWR/ZDA
3. Depth :	DPT/DBK/DBT/DBS
4. Wind :	MWV/MWD
5. Current :	
→Data Set Number :	0-9. Set the number of the sentence to be used by Data Set Number. (Initial value 0)
→Layer A :	Set the number of the sentence to be used with layer A by Layer Number. (Initial value 3)
→Layer B :	Set the number of the sentence to be used with layer B by Layer Number. (Initial value 4)
→Layer C :	Set the number of the sentence to be used with layer C by Layer Number. (Initial value 5)
6. Autopilot :	APB

### 7.2.1.4 Transmission Port Setting (TX Port)

For each sentence, set a communication port through which signals are transmitted to sensors.

#### Procedures

- 1) **Open the Serviceman Menu.**
- 2) **Perform the following menu open procedure to open the TX Port setting menu**

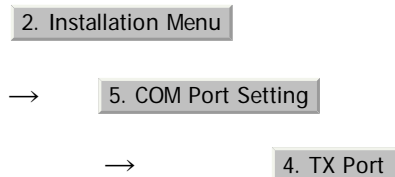

- 3) **Select the communication port through which the sentence to be set is output.**

Settable sentences	TTM(TT), TLL(TT), TTD(TT), TLB(TT), OSD, RSD, ALR, ACK, TTM(AIS), TLL(AIS), TTD(AIS), TLB(AIS), RemoteMaintenance, JRC-ARPA, APB, BOD, GGA, GLL, RMC, RMB, VTG, XTE, BWC, HDT, THS
Selectable ports	MAINTENANCE, NAV1, NAV2, ALARM, JARPA, ARPA, COM

- 4) **Select the output format, talker, and transmission interval.**

Signals for which the above items can be set:

Item	Name	Option
NMEA0183 Output Format	APB, BOD, GGA, GLL, RMC, RMB, VTG, XTE, BWC, HDT	V1.5 V2.0 <b>V2.3<sup>i</sup></b>
NMEA0183 Talker <sup>ii</sup>	APB, BOD, RMB, XTE, BWC, HDT, THS	<b>STANDARD</b> : The talker is RA . GP : The talker is GP.
NMEA0183 TX Interval	APB, BOD, GGA, GLL, RMC, RMB, VTG, XTE, BWC, HDT, THS	Set an interval in the range <b>1</b> to 9 seconds.

- i. The **bold** values are factory-set.
- ii. For TTM, TLL, OSD, RSD, and ALR, the talker is always RA .  
For GGA, GLL, RMC, and VTG, the talker is always GP.

## 7.2.2 Sector Blank Setting (Sector Blank)

In order not to display radar echoes, set a sector range and stop transmission in the bearing range. Three types of sectors can be created.

The sector blank function operates in the relative bearing with the bow as the benchmark.

### 7.2.2.1 Sector Blank Function On/Off (Sector1,2 and 3)

#### Procedures

- 1) Open the Serviceman Menu.
- 2) Perform the following menu open procedure to open the Sector Blank setting menu.

2. Installation Menu

→

3. Sector Blank

- 3) Set the sector blank number  ,  , or  with which the sector blank function operates.

The system allows the use of up to three sector blank areas.

Set each sector blank area to on or off.

: The sector blank function of the number is operated.

: The sector blank function of the number is stopped.

### 7.2.2.2 Sector Blank Area Creation (Make Sector 1,2,3)

#### Procedures

- 1) Open the Serviceman Menu.
- 2) Perform the following menu open procedure to open the Sector Blank setting menu.

2. Installation Menu

→

3. Sector Blank

- 3) Select the sector blank number (  to  ) for sector creation, and click the Make Sector button in the menu.

The selected sector blank will be made.



- 4) **Set the starting azimuth of the sector blank by operating the [EBL] dial, and left-click the ENT button.**

The start angle of the sector blank will be set.

- 5) **Set the ending azimuth of the sector blank by operating the [EBL] dial, and left-click the ENT button.**

The end angle of the sector blank will be set.

### 7.2.3 Setting of Bearing Pulses from Scanner Unit (Output Pulse)

Set the output value of bearing pulses from the scanner unit. The system can set 2048 pulses or 4096 pulses. This setting is enabled only when the scanner unit of 25 or 30 kW is used.

#### Procedures

- 1) **Open the Serviceman Menu.**
- 2) **Perform the following menu open procedure to open the Output Pulse setting menu.**

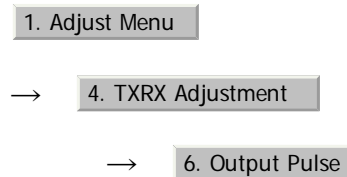

- 3) **Set the number of pulses to be output by the scanner unit.**

2048 <sup>i</sup> :2048 pulses per antenna rotation (Recommended value)

4096 :4096 pulses per antenna rotation

i. If a 10 kW antenna is used, 2048 is always set.

### 7.2.4 Slave Mode Setting (Master/Slave)

Place the system in the Slave mode when it is to be operated as the sub-display that displays radar echoes by using radar signals from other radar equipment.

The input value of externally input bearing pulses can be set. The system can set 2048 pulses or 4096 pulses.

### 7.2.4.1 Slave Mode Setting (Master/Slave)

#### Procedures

- 1) Open the Serviceman Menu.
- 2) Perform the following menu open procedure to open the installation setting menu.

2. Installation Menu

- 3) Select Slave for the item 2. Master Slave in the menu.

Master :The system operates as radar equipment while the own antenna is connected.

Slave :The system operates as a sub-display while the signal cable of other radar equipment is connected.

### 7.2.4.2 Setting of Input Bearing Pulse (Input BP Pulse)

#### Procedures

- 1) Open the Serviceman Menu.
- 2) Perform the following menu open procedure to open the second page of the installation setting menu.

2. Installation Menu

→ 9. Next

- 3) Set the number of pulses for the item 1. Input BP Count in the menu.

2048 : 2048 pulses per antenna rotation

4096 : 4096 pulses per antenna rotation

### 7.2.5 Language Setting (Language)

The system is designed to switch between display languages, Japanese and English.

#### Procedures

- 1) Open the Serviceman Menu.



- 2) **Perform the following menu open procedure to open the language setting menu.**



- 3) **Select the language to be used.**



- i. Other is an option to display character strings created by our overseas agents. Ask the overseas agent or our sales department if your language is supported. To determine the selected language, turn the power off, and then turn it on.

## 7.2.6 Date Time Setting

To display time, the local time, local date, and time-zone difference must be set.

However, if the "ZDA" sentence of NMEA0183 is received, time can be automatically displayed.

### Procedures

- 1) **Perform the following menu open procedure to open the Date Time setting menu.**

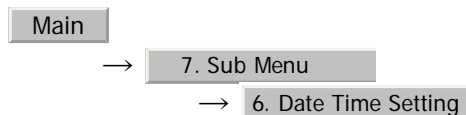

The Date Time Setting menu will open.

- 2) **Set information about date and time**

**2)-1. UTC/LMT (Time display system)**

- UTC** : Universal Time Coordinate
- UTC (S)** : UTC (System Time)
- LMT** : Local Mean Time
- LMT (S)** : LMT (System Time)

**2)-2. LMT Date**

Input the date in local time.

**2)-3. LMT Time**

Input the date in local time.

**2)-4. Time Zone**

Input the time-zone difference between the universal time and local time.

## 2)-5. Display Style

Set one of the following date display formats.

ex) 2007-12-31

ex) DEC 31, 2007

ex) 31 DEC, 2007

## 2)-6. Synchronize with GPS

A ZDA sentence sent by the GPS is used, thereby displaying time synchronized with the GPS time.

<sup>i</sup> : Time synchronized with the GPS time

: Time not synchronized with the GPS time

- i. If On is selected for this item but a ZDA sentence is not input, the system internal clock function is used to display the date and time.

## 7.2.7 Input Installation Information

The system can input installation information.

### Procedures

- 1) **Open the Serviceman Menu.**
- 2) **Perform the following menu open procedure to open the Installation Information setting menu.**

→

- 3) **Input the installation information.**

For the input method on the numeric value and character input screens, see Section 3.3.4 "Operation on Numeric Value, Latitude / Longitude and Character Input menu".

Input the date of installed system.

Input the name of installation personnel.

Input the name of radar installer.

## 7.2.8 Setting the Alarm System

### 7.2.8.1 Setting the reset interval (Reset Interval)

This function enables the control of WMRST terminal (on the terminal board circuit).The reset signal is turned on when operation in a set period of time.

### Procedures

- 1) **Open the Serviceman Menu.**
- 2) **Perform the following menu open procedure to open the Reset Interval menu.**

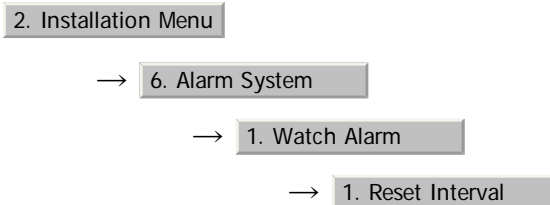

- 3) **Input the value to be set.**

For how to input numeric data on the numeric value input screen, see Section 3.3.4 "Operation on Numeric Value, Latitude / Longitude and Character Input menu".

#### 7.2.8.2 Setting the Trackball Threshold

This function enables the control of WMRST terminal (on the terminal board circuit).

The reset signal is turned off when trackball is moved, that caused by vibration.If trackball move distance go over the threshold (dot unit) when reset signal is turned on.

### Procedures

- 1) **Open the Serviceman Menu.**
- 2) **Perform the following menu open procedure to open the Trackball Threshold menu.**

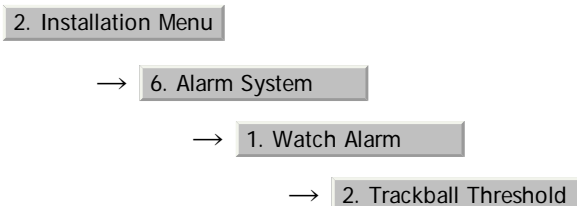

- 3) **Input the value to be set.**

For how to input numeric data on the numeric value input screen, see Section 3.3.4 "Operation on Numeric Value, Latitude / Longitude and Character Input menu".

#### 7.2.8.3 Setting the relay output (Relay Output)

This function enables the control of ARPAALM terminal (on the terminal board circuit).

### Procedures

- 1) **Open the Serviceman Menu.**

- 2) **Perform the following menu open procedure to open the Relay Output menu.**

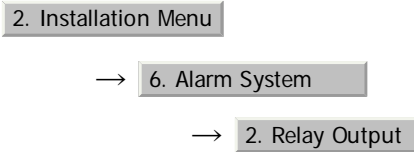

- 3) **Left-click the 1. Relay Output Mode button in the menu.**

The Relay Output mode is switched.

**Continuous** : The output is continuously controlled.

**Intermittent** : The output is intermittently controlled.

- 4) **Click the item button corresponding to the item to be changed.**

The item can be turned on / off.

**On** : The relay output is turned on when alarm have issued.

**Off** : The relay output is not turned on when alarm have issued.

**2. TT CPA/TCPA** : There is a dangerous target. (tracked target)

**3. AIS CPA/TCPA** : There is a dangerous target. (AIS target)

**4. New Target** : A new target is acquired in the automatic acquisition zone.

**5. Lost** : There is a lost target. (Target Tracking / AIS).

#### 7.2.8.4 Setting the ALR output (ALR Output)

This function enables the control of ALR port (See Section 7.2.1 "Communication Port Setting (COM Port Setting)").

##### Procedures

- 1) **Open the Serviceman Menu.**
- 2) **Perform the following menu open procedure to open the ALR Output menu.**

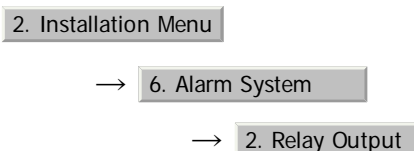

3) **Click the item button corresponding to the item to be changed.**

The item is turned on / off.

**On** : The ALR sentence is output when alarm have issued.

**Off** : The ALR sentence is not output when alarm have issued.

**1. System Alarm** : The internal alarm.

**2. TT/AIS Alarm** : Target Tracking Alarms and AIS Function Alarms.

### 7.2.8.5 Setting the External Acknowledgement (External ACK Setting)

This function enables the control of system when ACK sentence have received.

#### Procedures

1) **Open the Serviceman Menu.**

2) **Perform the following menu open procedure to open the External ACK Setting menu.**

**2. Installation Menu**

→ **6. Alarm System**

→ **5. External ACK Setting**

3) **Click the item button corresponding to the menu to be changed.**

**Critical Alarm** : CPA/TCPA alarm.

**Normal Alarm** : Exept Critical Alarm.

4) **Click the item button corresponding to the item to be changed.**

The item is switched.

**Audio** : Setting of alarm sound.

→ **On** : The alarm sound is not stopped when acknowledgement have received.

→ **Off** : The alarm sound is stopped when acknowledgement have received.

**Indication** : Setting of alarm indication.

→ **Lightning** : The alarm indication brinking is stopped when acknowledgement have received.

→ **Brinking** : The alarm indication brinking is not stopped when acknowledgement have received..

**Acknowledge State** : Setting of ALR sentence.

→ **A;ACK** : Add acknowledgement to ALR sentence.

→ **V;UNACK** : Add no acknowledgement (unrecognized) to ALR sentence.

**7.2.8.6 Setting the Alarm Buzzer (Sound Output Mode)**

This function enables the control of alarm buzzer.

**Procedures**

- 1) **Open the Serviceman Menu.**
- 2) **Perform the following menu open procedure to open the External ACK Setting menu.**

2. Installation Menu

→ 6. Alarm System

→ 4. Sound Output Mode

- 3) **Select the function to be used.**

**On** , **Off1** and **Off2**

Setting and Alarm Function

Alarm Setting	Operation	Operation Miss	CPA/TCPA	New Target	Lost	NAV	System	ISW
<b>On</b>					①			
<b>Off1</b>	①					②		
<b>Off2</b>	①			③		①	②	①

①: Followed by Buzzer Volume menu setting.

②: Alarm Buzzer is turned off.

③: If Relay Output menu is turned on when Alarm Buzzer is turned off. If Relay Output menu is turned off when Alarm Buzzer is turned on.

For how to setting Buzzer Volume menu, see Section 3.8.6 "Adjust Sound Volume (Buzzer Volume)".



# 7.3 ADJUSTMENT

This section describes the electrical adjustment procedures to be performed by service engineers during system installation.



## CAUTION



Do not carry out the adjustments of the equipment except authorized service persons. If wrong setting is carried out, this may cause unstable operation.

Do not carry out the adjustments during navigation. Otherwise, the radar performance may be affected, resulting in an accident or trouble.

### 7.3.1 Noise Level Adjustment (Noise Level)

#### 7.3.1.1 Noise Level Adjustment for Signal Processing

##### Procedures

- 1) Open the Serviceman Menu.
  
- 2) Perform the following menu open procedure to open the noise level adjustment menu.

9. RADAR/TT Initial Setup

→ 1. Signal Processing

→ 1. Echo Noise Level

- 3) Increase/decrease the noise level adjustment value.

The noise level is factory-set. (Initial value: 140)

After system installation, a great change in the noise level adjustment value should be avoided; it should be fine adjusted within  $\pm 5$ .

### 7.3.1.2 Noise Level Adjustment Mode (Setting Mode)

A noise level is factory-adjusted while this mode is turned on.

#### Procedures

- 1) **Open the Serviceman Menu.**
- 2) **Perform the following menu open procedure to open the noise level adjustment menu.**

9. RADAR/TT Initial Setup

→ 1. Signal Processing

→ 2. Setting Mode

The noise level adjustment mode is switched between on and off.

#### Factory-adjustment method

- The noise level adjustment value is once decreased to about 130.
- While the noise level adjustment value is gradually increased, the value with which radar echoes start turning yellow is determined as the set value.
- The noise level adjustment mode is turned off when the adjustment is finished.

## 7.3.2 Adjustment of Target Tracking Function (TT)

### 7.3.2.1 Vector Constant Adjustment (Vector Constant)

Adjust the vector follow-up performance of the target tracking function.

The vector constant is adjusted to an optimal value, so do not change it carelessly.

#### Attention

**Do not change the set value carelessly.**

**The vector constant shall be set to 5 normally. If the vector constant value is higher, a target's vector will be better followed up when the target and own ship change their course or speed, but the vector accuracy will be lower on the contrary.**

#### Procedures

- 1) **Open the Serviceman Menu.**
- 2) **Perform the following menu open procedure to open the Vector Constant adjustment menu.**

9. RADAR/TT Initial Setup

→ 2. TT

→ 1. Vector Constant

The window for setting vector constants will appear.

3) **Input the value to be set.**

For how to input numeric data on the numeric value input screen, see Section 3.3.4 "Operation on Numeric Value, Latitude / Longitude and Character Input menu".

**7.3.2.2 Quantization Level Adjustment (Video TD Level)**

Use the target tracking function (TT) to adjust the level of the signal to be recognized as a target. If a small value is set, even weak target signals will be input to the target detection circuit of the target tracking function. However, many unnecessary signals are also input, which may cause unstable target acquisition or tracking. It is important to set a value four or five greater than the value with which unnecessary signals are detected.

The quantization level is adjusted to an optimal value, so do not change it carelessly.



## CAUTION



**Do not change the set quantization level carelessly. If the level deviates from the proper value, the target acquisition and tracking functions will deteriorate. Otherwise, this may cause accidents.**

**Procedures**

- 1) **Open the Serviceman Menu.**
- 2) **Perform the following menu open procedure to open the target tracking setting menu.**

9. RADAR/TT Initial Setup

→ 2. TT

- 3) **To change the quantization level of the automatic acquisition area, specify the item 2. Video TD Level in the menu. To change the quantization level of tracking and manual acquisition, specify the item 3. Video High Level .**

- 4) **Input the value to be set.**

### 7.3.3 Main Bang Suppression Level Adjustment (MBS)

Main Bang Suppression is adjusted to suppress main bang, a reflection signal from 3D circuit including wave guide tube, that generally appears as a circular image focusing on the center of the radar display. Optimum adjustment allows main bang image to remain lightly on the display.



## CAUTION



**Do not change this adjusted level carelessly.**

**Incorrect adjustment may erase targets in point-blank range and cause collision, resulting in death or serious injury.**

#### 7.3.3.1 Adjustment of Main Bang Suppression Level (MBS Level)

##### Procedures

- 1) **Open the Serviceman Menu.**
- 2) **Perform the following menu open procedure to open the MBS level adjustment menu.**

9. RADAR/TT Initial Setup

→ 3. MBS

→ 1. MBS Level

- 3) **Set the radar as follows:**
  - Set the radar range to 0.125 NM.
  - Set the radar video enhance function (ENH) to OFF.
  - Set the image processing (PROC) to OFF.
  - Turn the [RAIN] control to the minimum position (fully to the left).
  - Turn the [GAIN] control to the maximum position (fully to the right).
  - Turn the [SEA] control to achieve the strength with which main bang can be judged.
- 4) **Adjust the value so that the main bang can be erased.**

### 7.3.3.2 Adjustment of Main Bang Suppression Area (MBS Area)

#### Procedures

- 1) Open the Serviceman Menu.
- 2) Perform the following menu open procedure to open the MBS Area adjustment menu.

9. RADAR/TT Initial Setup

→ 3. MBS

→ 2. MBS Area

- 3) Set the radar as follows:
  - Set the radar range to 0.125 NM.
  - Set the radar video enhance function (ENH) to OFF.
  - Set the image processing (PROC) to OFF.
  - Turn the [RAIN] control to the minimum position (fully to the left).
  - Turn the [GAIN] control to the maximum position (fully to the right).
  - Turn the [SEA] control to achieve the strength with which main bang can be judged.
- 4) Adjust the value so that the main bang can be erased.

### 7.3.4 Adjustment of Performance Monitor (SSR MON)

#### Attension

Replace the Antenna unit, TRX Module(CMN-750), performance monitor circuit (CAY-71), and radar process circuits (CHA-396, CDC-1349, CMH-2246), adjust the performance monitor according to the procedures in this section:

#### [i] Transmission Monitor Adjustment (Tx MON Adjustment)

#### Procedures

- 1) Set the master display unit for radar with the inter-switch function. (Interswitch is un-available for evaluation model.)
- 2) Open the Serviceman Menu.
- 3) Perform the following menu open procedure to open the “Tx Monitor Adjustment” menu.

#### 1.Adjust Menu

→4.TXRX Adjustment

→7.SSR MON Setting

→2. Tx MON Adjustment

- 4) Adjust the “Tx MON Adjustment” value to “0.0 ± 1.0dB” by operating the “+” / “-” button.
- 5) Left-click the “ENT” button.

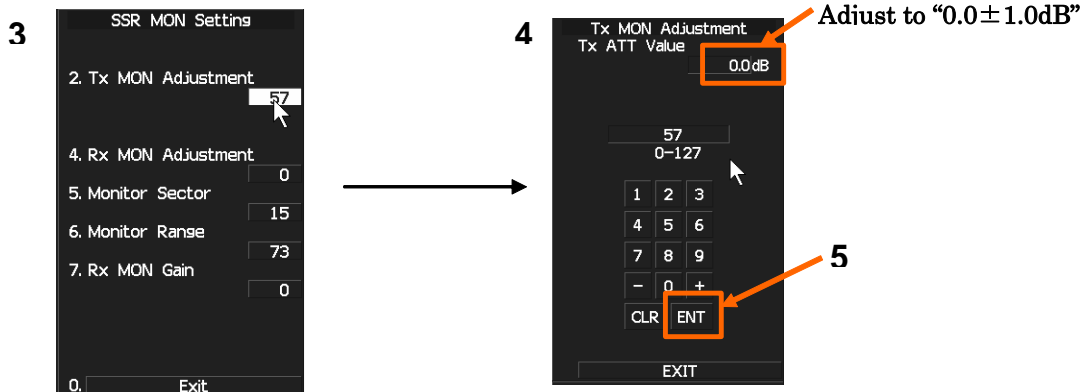

**[ii] Receiver Monitor Adjustment (Rx MON Adjustment)**

**Attention**

Do not change the parameters of “6. Monitor Range” and “7.Rx MON Gain” .

**Procedures**

- 1) Set the master display unit for radar with the inter-switch function. (Interswitch is un-available for evaluation model.)
- 2) Open the Serviceman Menu.
- 3) Perform the following menu open procedure to open the “Tx Monitor Adjustment” menu.

**1.Adjust Menu**

→4.TXRX Adjustment

→7.SSR MON Setting

→5. Monitor Sector

- 4) The +/- button is operated so that "Rx ATT Value" may become the maximum.  
*\*The PM Rx area(22.5° ) displayed on the PPI screen moves to operate "+/-" button.*
- 5) Perform the following menu open procedure to open the “Rx MON Adjustment” menu.
- 6) Adjust the “Rx MON Adjustment” value to “0.0 ± 1.0dB” by operating the “+” / “-” button.
- 7) Left-click the “ENT” button.

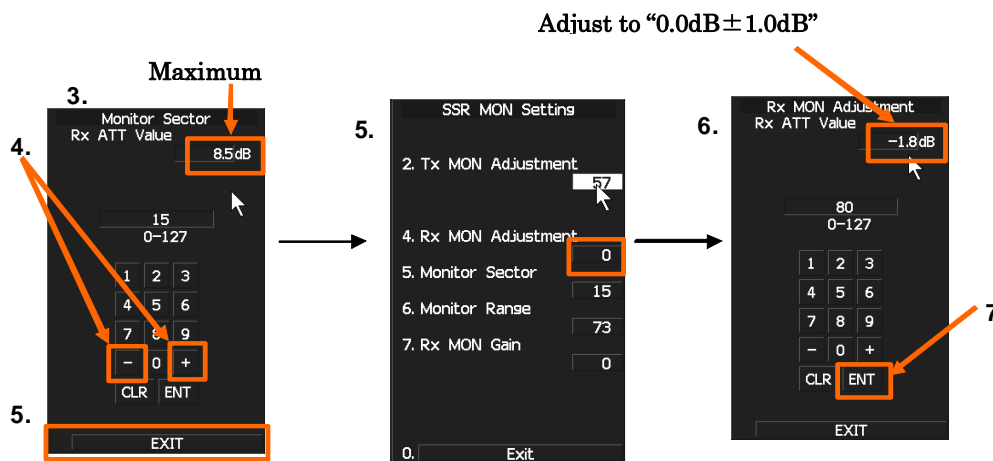



# 7.4 MAINTENANCE MENU

This item is provided for equipment maintenance, including settings of antenna safety switch, master reset, etc.



## CAUTION

 **Only our service engineers are to make the adjustment. Neglecting this caution may cause accidents and failures.**

 **Do not make the adjustments during navigation. Otherwise, adjustments may affect the radar functions, causing accidents and failures.**

## 7.4.1 Antenna Safety Switch (Safety Switch)

Use this switch to measure the transmission/reception performance while the antenna is in stopped state.

### Procedures

- 1) **Open the Serviceman Menu.**
- 2) **Perform the following menu open procedure to open the Safety Switch setting menu.**

3. Maintenance Menu

→ 1. Safety Switch

- 3) **Select the item to be set.**

Set operation when the antenna safety switch is turned off.

**1. TX-OFF** : The transmitter stops transmission. The screen on the display unit remains in transmission state.

**2. Standby** : (Normal setting) The transmitter stops transmission. The screen on the display unit is placed in standby state.

**3. TX-ON** : The transmitter continues transmission. The screen on the display unit remains in transmission state. In this case, however, an error such as a bearing signal failure occurs because the safety switch is turned off.

- 4) **Change the setting back to 2. Standby when the work is finished.**



## 7.4.2 Initialization of Memory Area(Area Initial)

If system operation is unstable, it may be stabilized by initializing the memory area. To initialize the memory area, follow the procedure in this section. The memory area is reset to the factory setting when initialized.

### 7.4.2.1 Partial Master Reset

#### Procedures

- 1) **Open the Serviceman Menu.**
- 2) **Perform the following menu open procedure to open the Partial Master Rest operation menu for the memory area.**

3. Maintenance Menu

→ 2. Area Initial

→ 1. Partial Master Reset

- 3) **Select the items to be initialized.**

1. Serviceman Menu : The set values in the Serviceman menu are initialized.

2. Except Serviceman Menu : The set values not in the Serviceman menu are initialized.

3. User Setting : The user-set values are initialized.

4. TT Setting : The set values for the target tracking function are initialized.

5. AIS Setting : The set values for the AIS display function are initialized.

6. Day/Night : The color scheme and brilliance setting for the day/night mode are initialized.

- 4) **Select 1. Yes in the Confirmation Menu.**

The memory areas of specified items are initialized, and the system is restarted.

### 7.4.2.2 All Master Reset

#### Procedures

- 1) **Open the Serviceman Menu.**
- 2) **Perform the following menu open procedure to open the All Master Rest operation menu for the memory area.**

3. Maintenance Menu

→ 2. Area Initial

→ 2. All Master Reset

- 3) **Select 1. Yes in the Confirmation Menu.**

The whole memory area is initialized, and the system is restarted.

## 7.4.3 Save of Internal Memory Data (Card1/2)

The system can save internal memory data such as item settings in all menus onto a flash memory card. If the radar processing circuit in the system has been replaced, the set values before the circuit replacement can be restored by reading the set values you saved before the replacement.

To save the internal memory data onto a flash memory card (option), the card must be inserted in card slot beforehand.

### 7.4.3.1 Copying of Internal Settings onto Card (Internal To Card1/2)

Save the internal memory data, such as item settings in menus, onto a flash memory card.

The internal memory data should be saved at completion of system setting, and the operation condition should be saved periodically.

#### Procedures

- 1) **Open the Serviceman Menu.**
- 2) **Open the** 3. Maintenance Menu **.**
- 3) **Select** Slot2 **in the** 3. Internal To Card1/2 **.**
- 4) **Select** 1. Yes **in the Confirmation Menu.**

The internal memory data is saved on the flash memory card.

### 7.4.3.2 Reading of Internal Settings from Card (Card1/2 To Internal)

Read the saved memory data from the flash memory card into the system memory.

Perform the read operation in order to return the system to the previous operation condition after replacement of the radar processing circuit in the system.

#### Procedures

- 1) **Open the Serviceman Menu.**
- 2) **Open the** 3. Maintenance Menu **.**
- 3) **Select** Slot2 **in the** 4. Card1/2 To Internal **.**
- 4) **Select** 1. Yes **in the Confirmation Menu.**

The memory data is read from the flash memory card into the system memory.

After the internal memory area is updated, the system is restarted.

## 7.4.4 Restoration of Scanner Unit Operation Time (TXRX Time)

The system adds up the following operation time and contains it in the scanner unit:

- Transmission time
- Motor run time

Clear the above total time when scanner unit motor is replaced.

### 7.4.4.1 Clear of Motor Run Time (Clear TX Time)

Clear the scanner's motor run time.

Perform the following procedure to clear the motor run time when the scanner motor is replaced.

#### Procedures

- 1) **Open the Serviceman Menu.**
- 2) **Perform the following menu open procedure to open the Clear Motor Time menu.**

3. Maintenance Menu

→ 5. TXRX Time

→ 1. Clear TX Time

- 3) **Select 1. Yes in the Confirmation Menu.**

The motor run time in the TXRX's internal control circuit is cleared to 0.

### 7.4.4.2 Save of Antenna Time (Clear Motor Time)

Save the following scanner unit time data from the scanner unit into the display unit.

Perform the following procedure to inherit the scanner unit time data when the TXRX's internal control circuit is replaced.

#### Procedures

- 1) **Open the Serviceman Menu.**
- 2) **Perform the following menu open procedure to open the Clear Motor Time menu.**

3. Maintenance Menu

→ 5. TXRX Time

→ 2. Clear Motor Time

- 3) **Select 1. Yes in the Confirmation Menu.**

The motor run time in the TXRX's internal control circuit is cleared to 0.

### 7.4.4.3 Save of Scanner Unit Time (TXRX To Display Unit)

Save the following scanner unit time data from the scanner unit into the display unit.

Perform the following procedure of 7.4.4.4 to inherit the scanner unit time data when the TXRX's internal control circuit is replaced.



During performance monitor adjustment, all acquisitions by the target tracking function are released.  
The released target acquisitions are not recovered.

#### Procedures

- 1) **Open the Serviceman Menu.**
- 2) **Perform the following menu open procedure to open the TXRX to Display Unit menu.**

3. Maintenance Menu

→ 5. TXRX Time

→ 3. TXRX To Display Unit

- 3) **Select 1. Yes in the Confirmation Menu.**

The scanner unit time data in the TXRX's internal control circuit is saved transferred to the display unit.

### 7.4.4.4 Restoration of Antenna Time (Display Unit To TXRX)

Restore the antenna time data from the display unit into the antenna's internal control circuit.

Perform the above procedure of 7.4.4.3 to inherit the antenna time data when the antenna's internal control circuit is replaced.

#### Procedures

- 1) **Open the Serviceman Menu.**
- 2) **Perform the following menu open procedure to open the Display Unit to TXRX menu.**

3. Maintenance Menu

→ 5. TXRX Time

→ 4. Display Unit To TXRX

- 3) **Select 1. Yes in the Confirmation Menu.**

The scanner unit time data in the display unit is restored transferred to the antenna's internal control circuit.

## 7.4.5 Update of Character String Data (String Data Update)

The system is designed to transfer and display external character strings as the second language display. The second language is factory-set to "Japanese."

Ask our agent or sales department for the supply of character strings to be updated.

To update character strings, the flash memory card (option) containing the character string file must be inserted in card slot 2.

### Procedures

- 1) **Open the Serviceman Menu.**
- 2) **Perform the following menu open procedure to open the String Data Update menu.**

3. Maintenance Menu

→ 6. String Data Update

- 3) **Select 1. Yes in the Confirmation Menu.**

The character string file on the flash memory card is read into the system, and the second language area is updated.

To display the read character strings in the second language, select **Other** in the menu shown in Section 7.2.5 "Language Setting (Language)".

# SECTION 8

## COUNTERMEASURES FOR TROUBLE AND ADJUSTMENT

### COUNTERMEASURES FOR TROUBLE AND ADJUSTMENT

8.1	ROUTINE MAINTENANCE .....	8-1
8.2	MAINTENANCE ON EACH UNIT .....	8-2
8.2.1	Scanner Unit (NKE-1532) .....	8-2
8.2.2	Display Unit (NCD-9170) .....	8-4
8.3	PERFORMANCE CHECK .....	8-5
8.3.1	Check Performance on Test Menu .....	8-5
8.3.1.1	Self-diagnosis function (Self Test) .....	8-6
8.3.1.2	Monitor Test .....	8-8
8.3.1.3	Operation Unit Test (Keyboard Test) .....	8-8
8.3.1.4	Check of the Performance Monitor (MON Display) .....	8-9
8.3.1.5	System Alarm Log display .....	8-10
8.3.1.6	System Information .....	8-10
8.4	REPLACEMENT OF MAJOR PARTS .....	8-12
8.4.1	Parts Required for Periodic Replacement .....	8-12
8.4.2	Replacement of Motor .....	8-12
8.4.3	Replacement of LCD .....	8-17

<b>8.4.5</b>	<b>Replacement of Backup Battery .....</b>	<b>8-20</b>
<b>8.4.5.1</b>	<b>About the Battery Alarm .....</b>	<b>8-20</b>
<b>8.4.5.2</b>	<b>How to Replacement of Backup Battery .....</b>	<b>8-20</b>

# 8.1 ROUTINE MAINTENANCE



## WARNING



- Never carry out internal inspection or repair work of the equipment by users. Inspection or repair work by unauthorized personnel may result in fire hazard or electric shock. Ask the nearest branch, business office or a dealer for inspection and repair.



- Turn off the main power before maintenance work. Otherwise, an electric shock may result.



- Turn off the main power before cleaning the equipment. Especially, make sure to turn off the indicator if a rectifier is used. Otherwise, equipment failure, or death or serious injury due to electric shock may result, because voltage is outputted from the rectifier even when the radar is not operating.

For operating the radar equipment in the good conditions, it is necessary to make the maintenance work as described below. If maintenance is made properly, troubles will reduce. It is recommended to make regular maintenance work.

Common points of maintenance for each unit are as follow:

- Clean the equipment.

Remove the dust, dirt, and sea water rest on the equipment cabinet with a piece of dry cloth.

Especially, clean the air vents with a brush for good ventilation.





# 8.2

## MAINTENANCE ON EACH UNIT

### 8.2.1 Scanner Unit NKE-1532



## WARNING

- 
  - Turn off the main power source before starting maintenance. Otherwise, an electric shock or injury may be caused.
- 
  - Turn "OFF"<sup>i</sup> the safety switch to stop the scanner unit. (Refer to Section 1.4 "EXTERIOR DRAWINGS".) Otherwise, you may be injured if touching the rotating scanner unit by accident.
- 
  - Do not touch the radiator. Even if the power is turned off, the radiator may be rotated by the wind.

i. After the work, turn "ON" the scanner unit safety switch.

#### a. Precautions in Mounting the Cover

When the cover is removed for regular checkup and replacement of parts and refitted after such work, the procedures of fastening bolts shall be taken with the following precautions:

- 1) **The proper fastening torque of the fitting bolts (M8) is 1176 to 1470 N/cm (120 to 150kgf/cm) (which makes the inside water-tight and protects the packings against permanent compressive strain).The packings start producing from the cover at a torque of approximately 1470N/cm (150kgf/cm). Do not fasten the bolts with a torque exceeding the specified value. Otherwise, the screws may be broken.**
- 2) **Use an offset wrench of 11 mm X 13 mm or a double-ended wrench of 13 mm X 17 mm (not longer than 200 mm).**
- 3) **Screw all the bolts by hand first to prevent them playing, then fasten them evenly in order not to cause one-sided fastening. (Fasten the bolts with 25% of the required torque at the first step.)**

\*Fasten the bolts in the diagonal order.

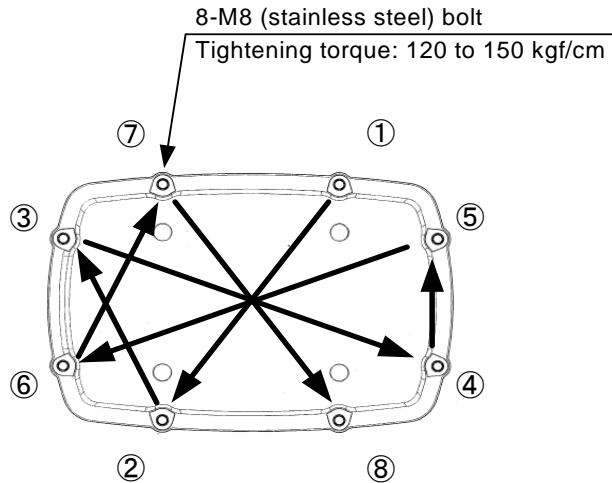

Bolt Tightening Procedure of  
NKE-1532 Cover

b. Radiator

Attention

- If the radiator front face (radiation plane) is soiled with smoke, salt, dust, paint or birds' droppings, wipe it with a piece of soft cloth wetted with alcohol or water and try to keep it clean at all times. Otherwise, radar beam radiation may attenuate or reflect on it, resulting in deterioration of radar performance.
- Never use solvents of gasoline, benzine, trichloroethylene and ketone for cleaning. Otherwise, the radiation plane may deteriorate.

Check up and clean the radiator.

### c. Rotating section

#### c-1 Supply Oil Seal

An scanner unit with a grease nipple needs grease supply. Remove the cap on the grease nipple located on the front of JMA-9172-SA radar at which the radiator is supported, and grease with a grease gun. Make the oiling every six months. The oil quantity shall be approximately 100 g, which is as much as the grease comes out of the oil seal. Use the grease of Mobilux 2 of Mobil Oil.

#### c-2 Oiling gears



Apply grease evenly to the tooth surfaces of the main shaft drive gear and the encoder drive gear with a spreader or brush. Oiling in short intervals is more effective to prevent the gears from wear and tear and extend their service life, but oil at least every six months.

Use Mobilux2 of Mobile Oil.

#### c-3 Mounting legs

Check the mounting legs and mounting bolts of the antenna unit case for corrosion at intervals and maintain them to prevent danger. Apply paint to them once a half year because painting is the best measure against corrosion.

## 8.2.2 Display Unit (NCD-9170)

	<h1>WARNING</h1>
	<ul style="list-style-type: none"><li>• <b>When cleaning the screen, do not wipe it too strongly with a dry cloth. Also, do not use gasoline or thinner to clean the screen. Otherwise the screen surface may be damaged</b></li></ul>

Dust accumulated on the screen will reduce clarity and darken the video. For cleaning it, wipe it with a piece of soft cloth (flannel or cotton).

Do not wipe it strongly with a piece of dry cloth nor use gasoline or thinner.

# 8.3

## PERFORMANCE CHECK

Make operational check on the radar equipment regularly and if any problem is found, investigate it immediately. Pay special attention to the high voltage sections in checking and take full care that no trouble is caused by any error or carelessness in measurement. Take note of the results of checking, which can be used effectively in the next check work.

Operational check shall be made in accordance with Table 8-1 Function Check List in the order as specified in it.

Table8-1 : Performance Check List

Equipment	Item to be checked	Criteria	Remarks
Display Unit	Video and echoes on the screen Sensitivity LCD brilliance can be controlled correctly Various markers Various numerical indications Lighting	Can be correctly controlled	
	Memory	See the Section [1] "Memory Test"	
	Communications Lines	See the Section [3] "Check of Communication Lines (Line Test)"	
	Power Supply, Backup Battery	See the Section [4] "Supply Voltage"	
	Monitor	See the Section 8.3.1.2 "Monitor Test"	
	Operation Unit	See the Section 8.3.1.3 "Operation Unit Test (Keyboard Test)"	
	System Alarm Log Display	See the Section 8.3.1.5 "System Alarm Log display"	
	System Information Display	See the Section 8.3.1.6 "System Information"	
	Target Tracking	See the Section 5.2.7 "Operation Test (TT Test Menu)"	
Scanner Unit	Signals from the Scanner Unit	See the Section [2] "TXRX Test"	
	Performance Monitor	See the Section 8.3.1.4 "Check of the Performance Monitor (MON Display)"	

### 8.3.1 Check Performance on Test Menu

The radar operating state can be checked by opening the Test Menu.



## Procedures

- 1) Perform the following menu open procedure to open the Test Menu.

Main

→ 9. Test Menu

- 2) Select the items to be checked.

- |                       |  |
|-----------------------|--|
| 1. Self Test          | 8.3.1.1 Self-diagnosis function (Self Test)            |
| 2. Monitor Test       | 8.3.1.2 Monitor Test                                   |
| 3. Keyboard Test      | 8.3.1.3 Operation Unit Test (Keyboard Test)            |
| 4. MON Display        | 8.3.1.4 Check of the Performance Monitor (MON Display) |
| 5. System Alarm Log   | 8.3.1.5 System Alarm Log display                       |
| 6. System Information | 8.3.1.6 System Information                             |

The list of check items will appear.

### 8.3.1.1 Self-diagnosis function (Self Test)

Check of memory, scanner unit, and communications Lines

- |                   |  |
|-------------------|--|
| 1. Memory Test    | [1] Memory Test                              |
| 2. TXRX Test      | [2] TXRX Test                                |
| 3. Line Test      | [3] Check of Communication Lines (Line Test) |
| 4. Supply Voltage | [4] Supply Voltage                           |

#### [1] Memory Test

---

Checks for the performance of built-in memory.

- |              |                 |
|--------------|-----------------|
| 1. SDRAM     | SDRAM Check     |
| 2. SRAM      | SRAM Check      |
| 3. FLASH ROM | FLASH ROM Check |
| 4. GRAPHIC   | GRAPHIC Check   |

When no abnormality is found, OK is displayed. When an abnormality is found, NG is displayed.

#### [2] TXRX Test

---

Checks for signals from the scanner.

- |               |                               |
|---------------|-------------------------------|
| Safety Switch | Scanner's safety switch check |
|---------------|-------------------------------|

AZI Pulse	Scanner rotation signal check
HL Pulse	Heading line signal check
MH Current	Check on the load current of high voltage in the modulator
Trigger	Radar trigger signal check
Video	Radar video check

When no abnormality is found, OK is displayed. When an abnormality is found, NG is displayed.

In standby, \*\* will appear.

### [3] Check of Communication Lines (Line Test)

Check the status of communications with options.

TXRX	Check on connection with the transmitter-receiver
SIG. PROC	Check on connection with the signal processing circuit
TT	Check on connection with the target tracking unit
GYRO I/F	Check on connection with the GYRO I/F unit
ISW	Check on connection with the interswitch

When no abnormality is found, OK is displayed. When an abnormality is found, NG is displayed.

The status display field of equipment not connected is left blank.

### [4] Supply Voltage

Check the voltage of internal power supply.

Item	Normal operating range
<b>12V</b>	11.4 to 12.6V
<b>5V</b>	4.75 to 5.25V
<b>3.3V</b>	3.14 to 3.46V
<b>Battery</b>	2.5V or more

### 8.3.1.2 Monitor Test

Checks for the display.

The test pattern will be shown on the display.

- 1. Pattern1 : All colors are filled with white.
- 2. Pattern2 : A white box is displayed on the black background of 1280 × 1024dot.
- 3. Pattern3 : Displays rectangle X 2, circle X 2, and cross-shape X13 (white lines on the black background).
- 4. Pattern4 : Displays “H” of 9 dots X 9 dots on the entire screen (white character on the black background).
- 5. Pattern5 : Gray scale display (16 levels)
- 6. Pattern6 : Displays a color bar.
- 7. Pattern7 : Displays the VDR test pattern.
- 8. Pattern8 : Displays the specified color.

To return to the normal display, press any key.

If errors occur in the monitor, no test pattern will appear.

### 8.3.1.3 Operation Unit Test (Keyboard Test)

Checks for the controls and switches of the operation panel.

- 1. Key Test [1]Key Test
- 2. Buzzer Test [2]Buzzer Test
- 3. Light Test [3]Light Test

---

#### [1] Key Test

Checks for the controls and switches of the operation panel.

Each key on the operation panel on the display is shown in reverse video at the same time the key is pressed, and the name of the pressed key is displayed.

---

#### [2] Buzzer Test

Checks for the operation panel buzzer.

The buzzer will sound. The buzzer automatically stops after it sounds for a specified length of time.

---

#### [3] Light Test

Checks for the control panel light.

The brightness of the operation panel is gradually intensified at four levels.

### 8.3.1.4 Check of the Performance Monitor (MON Display)

#### Procedures

- 1) Perform the following menu open procedure to open the “4. MON Display menu” .

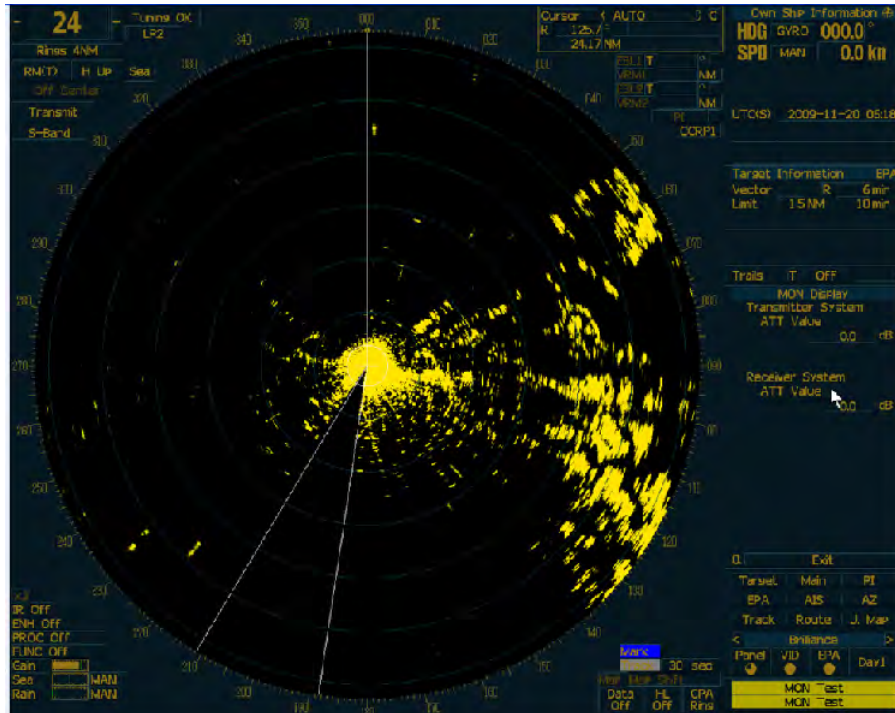

Blind sector appears on stern direction of ship to check receiver performance. Range scale will be automatically changed to 24nm. Sea and Rain dial will be automatically changed to minimum, and IR, ENH, PROC and FUNC will be automatically changed to off. Push “EXIT” button, it will be returned to former state.

- 2) **Check the Transmitter System ATT Value and Receiver System ATT Value.**



If Transmitter System ATT Value down > 7.0dB or Receiver System ATT Value down > 3.0dB, Please consult the purchased distributor or nearest branch office (or our sales department).

Note: Features of Performance monitor of JMA-9172-SA radar

-The performance of the receiver and the transmitter is automatically calculated and indicated on the radar screen like XX.X dB in two or three-digit value.

-Receiver check is performed within the PM sector in direction of stern of ship. Therefore, even if the performance monitor is activated, the performance monitor pattern echo like the performance monitor of the magnetron radar is not displayed at all. As a result, the radar operator can clearly observe the echo around ships other than the direction of the stern.



### 8.3.1.5 System Alarm Log display

Displays previously occurred system alarms with the dates and times when they occurred.

The current alarm is displayed at the lower right of the radar display. For details, refer to Section 9.1.1 "List of Alarms and other Indications".

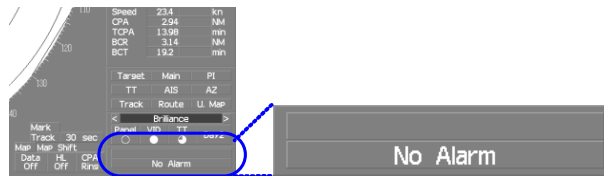

The Alarm log display button (page2-31 Alarm) is clicked, in the same way as that one.

To erase the alarm logs, press the  button in the log display window.

### 8.3.1.6 System Information

Displays the current system information.

<input type="button" value="Indicator"/>	Processor software version information
<input type="button" value="TXRX"/>	Scanner software version information
<input type="button" value="System No."/>	System number
<input type="button" value="TX Time"/>	Total transmitting time
→ <input type="button" value="S-Band"/>	
<input type="button" value="Motor Time"/>	Total operating time (Total power-on time)
<input type="button" value="TXRX Total Time"/>	Total operating (power-on) time of the scanner unit
<input type="button" value="Total Time"/>	Total operating (power-on) time of the display unit

## 8.4 REPLACEMENT OF MAJOR PARTS

The system includes parts that need periodic replacement. The parts should be replaced as scheduled. Use of parts over their service life can cause a system failure.



### CAUTION



- Turn off the main power source before replacing parts. Otherwise, an electric shock or trouble may be caused.



- Two or more persons shall replace the liquid crystal monitor. If only one person does this work, he may drop the LCD, resulting in injury.



- Even after the main power source is turned off, some high voltages remain for a while. Do not contact the inverter circuit in the LCD with bare hands. Otherwise, an electric shock may be caused.

## 8.4.1 Parts Required for Periodic Replacement

Here are parts required for periodic replacement

Part name	Interval	Part type	Part code
1. Motor	10,000 hours	MDBW10823 <sup>*i</sup>	MDBW10823 <sup>*i</sup>
2. Fan (Scanner Unit)			
$\phi$ 120mm (Radar process Unit)	90,000 hours	H-7ZCRD1569 <sup>*i</sup>	7ZCRD1569 <sup>*i</sup>
$\phi$ 92mm <sup>*ii</sup> (Radar process Unit)	45,000 hours	H-7ZCRD1570 <sup>*i</sup>	7ZCRD1570 <sup>*i</sup>
$\phi$ 60mm (Motor Driver)	45,000 hours	H-7ZCRD1572 <sup>*i</sup>	7ZCRD1572 <sup>*i</sup>
$\phi$ 60mm (Power Supply Unit)	45,000 hours	H-7ZCRD1574 <sup>*i</sup>	7ZCRD1574 <sup>*i</sup>
3. LCD PANEL	50,000 hours	7WASR002 <sup>*i</sup>	7WASR002 <sup>*i</sup>
4. Fan (Display Unit)			
(Radar Process Circuit)	20,000 hours	109R0612S4D13	5BFAB00588
(Power Supply)	20,000 hours	H-7BFRD0006 <sup>*i</sup>	7BFRD0006 <sup>*i</sup>
5. Backup battery	5 years	CR2032	5ZBCJ00012

- i. “\*” means revision, such as A, B and so on.
- ii. The  $\phi$  92mm Fan is auxiliary use of the  $\phi$  120mm Fan.

## 8.4.2 Replacement of Motor



Replacement of motor must be made by specialized service personnel.

For details, refer to Service Manual.

### 8.4.2.1 Scanner Unit NKE-1532

[Required tools]

- Wrenches (M5, M8, and M10)
- A Phillips screwdriver (M2)

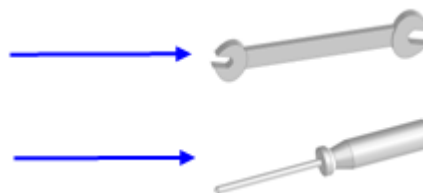

[Required procedure]

### Removal of the pedestal cover

- 1) Turn off the safety switch of the scanner before replacing the motor.

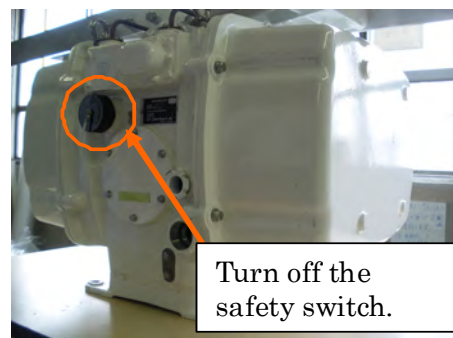

- 2) *Remove the pedestal cover of the port side and the starboard side.*

*Make sure that there is no foreign matter or dust adhered to the gasket when you put the cover on.*

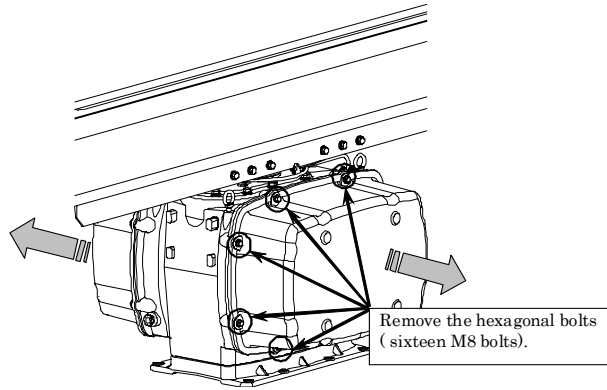

### Work of Port side

- 3) *Loosen the hexagonal bolts. (four M5 bolts)*  
*And, remove the motor driver unit.*

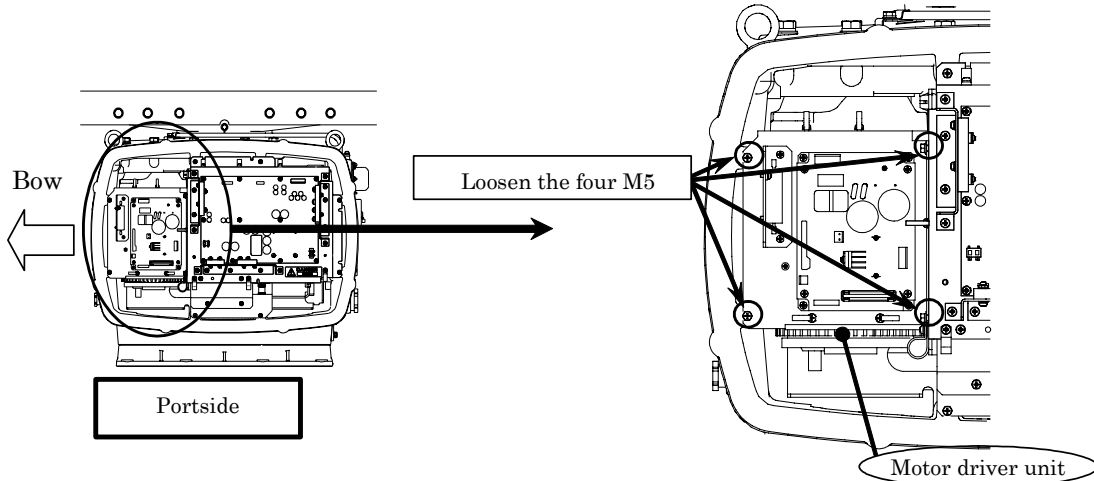

- 4) *Remove the relay connector (P1901) connected to the motor driver unit.*

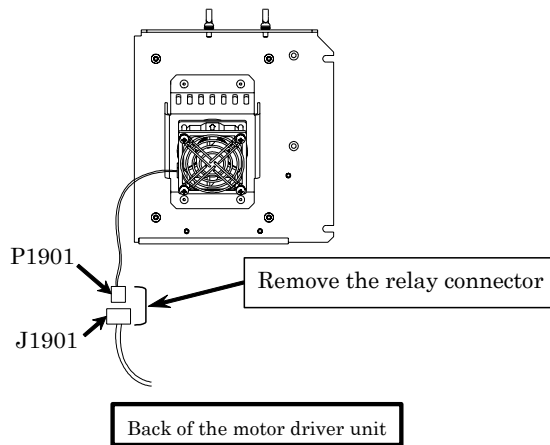

## Work of Starboard side

- 5) Remove the screws (two M4 screws) and the bolts (six M5 bolts) of the radar process unit.

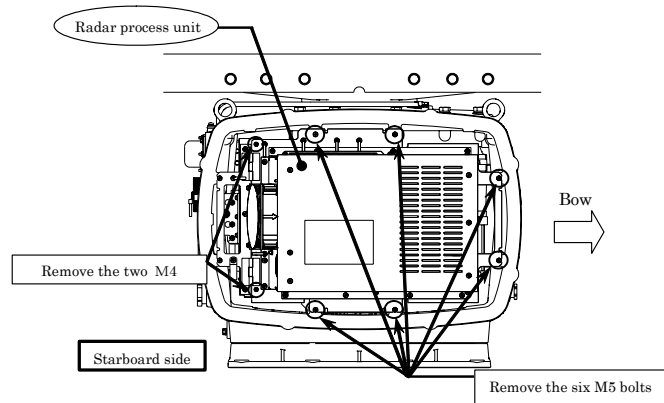

- 6) Pull the radar process unit to the open-position.

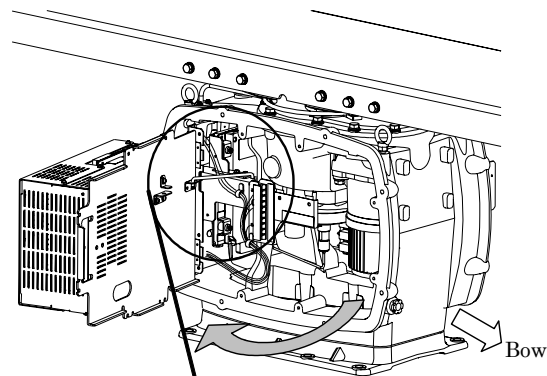

- 7) Loosen the M4 screw.

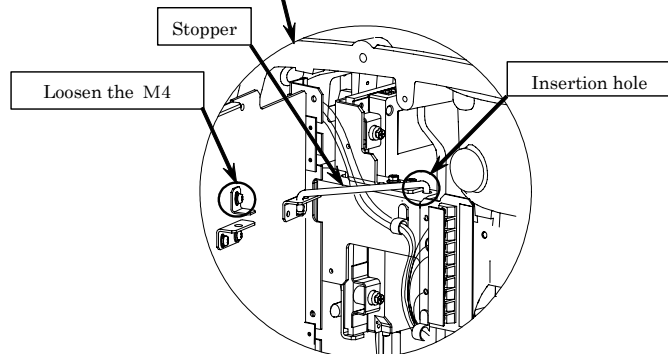

- 8) Hook the stopper in the insertion hole.

## 4.Replacement of Motor

- 9) *Remove the bolts (two M10 bolts) on the portside of the motor.*

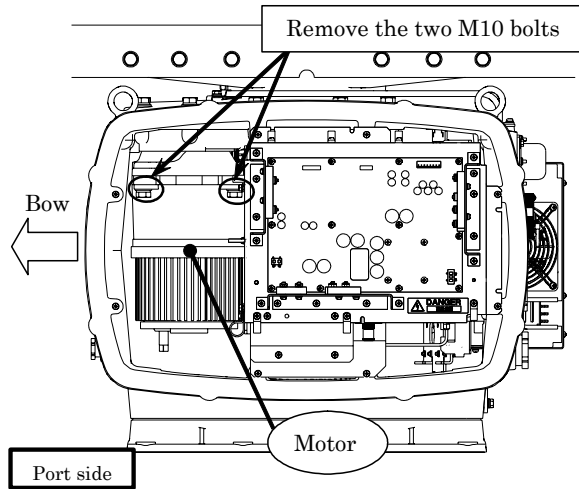

- 10) *Remove the bolts (two M10 bolts) on the starboard side of the motor*

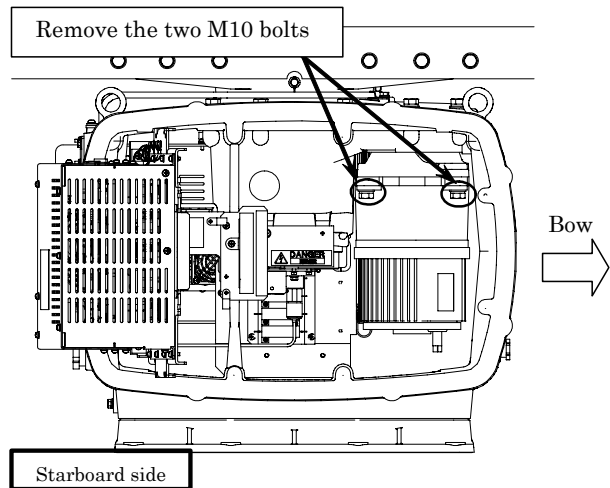

- 11) *Remove the motor.*

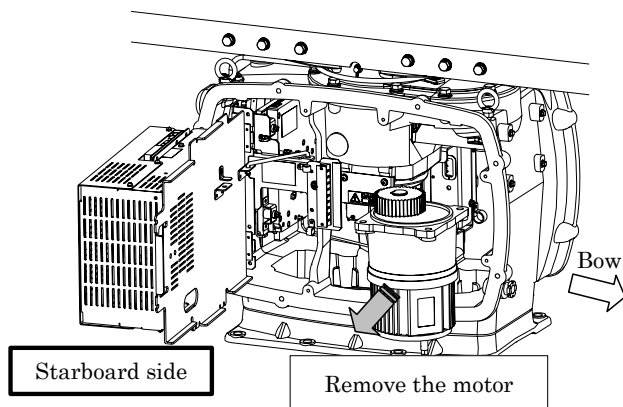

12) Grease the gear wheel of the new motor.

13) Install the new motor in the scanner unit and secure it using the hexagonal bolts.  
Tighten the bolts with the specified torque (380 kgf-cm).

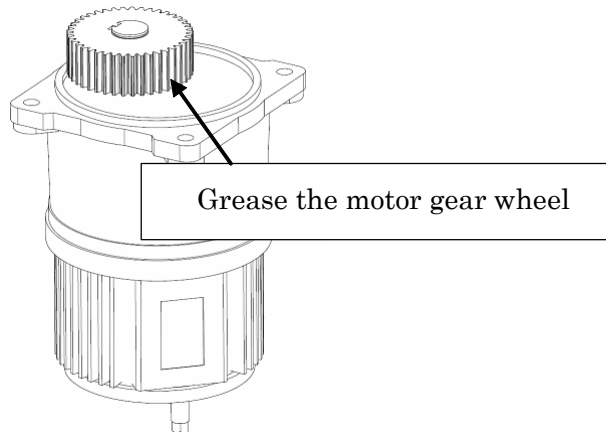

14) After replacing the motor, and assemble the unit in the reverse order of the disassembly procedure.

**CAUTION**  
Do not forget to tighten the screws and bolts .

**CAUTION**  
Do not forget to connect the cables.

[Operation check]

Follow the procedure below to check the operation after you have replaced the motor.

- 1) Turn on the radar power supply. When the Countdown is completed, push the "TX / STBY" button and check that the radar image appears without error. Check that you do not listen any unusual sound starting, rotating, and stopping the motor.
- 2) Open the service engineer menu, and initialize the motor rotation time.

### 8.4.3 Replacement of 23inch LCD

 Replacement of LCD monitor must be made by specialized service personnel.  
For details, refer to Service Manual.

 **CAUTION**  
Do not touch the LCD screen directly with your fingers.

 **CAUTION**  
Do not touch the AR filter directly with your fingers.

 **CAUTION**  
Perform the replacement work on a soft cloth to avoid damage to the LCD screen and other parts.

[Required tools]

- A Phillips screwdriver for 4 mm screws
- A Phillips screwdriver for 6 mm screws

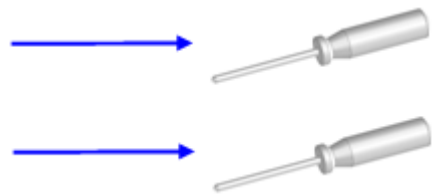

[Disassembly]

- 1) *Remove the tilt fixing handle (standalone type only).*
- 2) *Tilt up the screen as much as you can (standalone type only).*
- 3) *Remove the screws (M6) from the four corners and displace the face cover.*

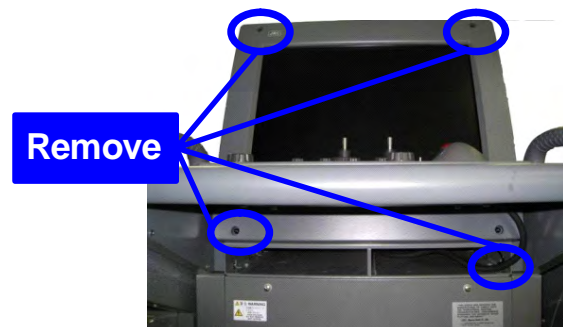
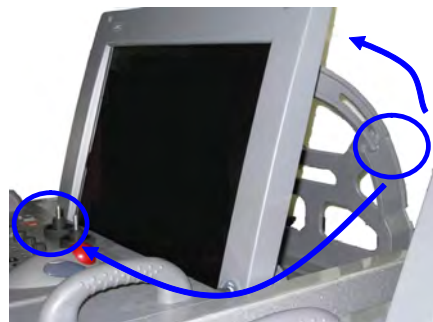



- 4) *Remove the LCD operation circuit cables and remove the face cover.*

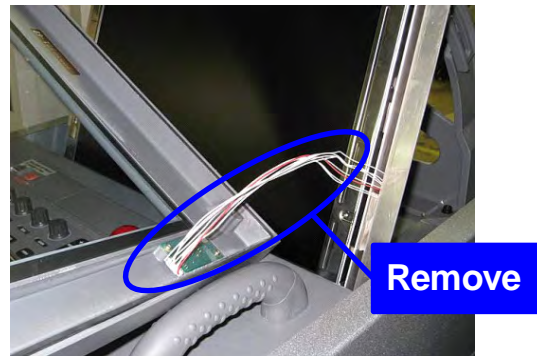

- 5) *Remove six M4 screws.*

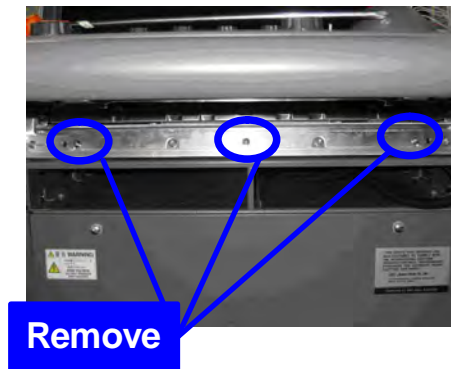
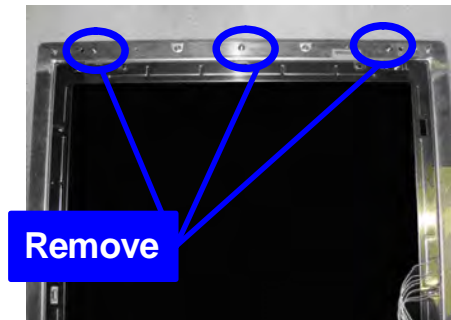

- 6) *Displace the module and remove the three cables.*

- 7) *Remove the LCD module.*

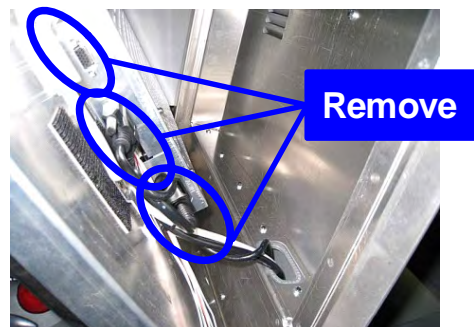

[Assembly]

- 1) *Tighten the lower three M4 screws halfway.*
- 2) *Connect the cables to the LCD module.*
- 3) *Align the module to the lower three screws and insert it downward.*
- 4) *Check the positions of the two bosses and ensure that appropriate space is maintained under the LCD module. Tighten the six screws evenly.*
- 5) *Connect the LCD operation circuit cables and attach the face cover.*
- 6) *Tighten the screws at the four corners.*
- 7) *Attach the tilt fixing handle.*

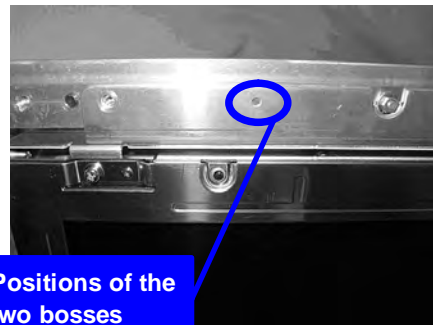
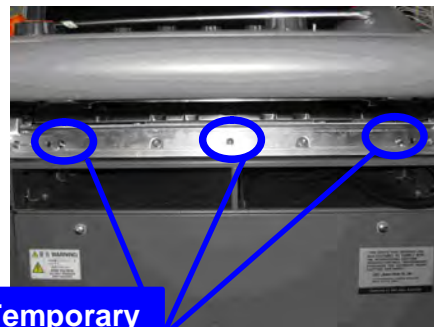

[Operation Check]

- 1) *After completing the replacement procedures, start the system to make sure that images are displayed properly.*
- 2) *Turn the brightness knob to make sure the brightness can be changed between the minimum and the maximum levels.*

## 8.4.4 Replacement of Backup Battery



Replacement of backup battery must be made by specialized service personnel.

For details, refer to Service Manual.

A coin-cell battery maintains radar system configuration, date, and time information while power off condition. Radar system configuration is saving to non-volatile memory at fixed intervals.

### 8.4.4.1 About the Battery Alarm

If **Battery Low** is appeared at the lower-right of the display when start up the radar system, the battery has not enough time left to live. We recommend to replace the battery.

If **Battery Dead** is appeared at the lower-right of the display when start up the radar system, the battery has no time left to live. There is a necessary to replace the battery. In This condition, this radar system is restored configuration information from flash memory and normal operation is available. However, you turned of the radar system before saving to flash memory, the configuration information is maybe lost. In this case, you must setup the configuration again.



About disposal of used battery, refer to Section 10.2.

### 8.4.4.2 How to Replacement of Backup Battery

[Required tools]

- A flat tip screwdriver for 6 mm screws
- A Phillips screwdriver for 4 mm screws
- A flat tip nonconductive screwdriver for 3 mm screws

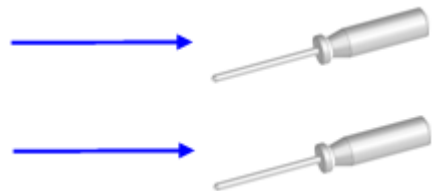

[Disassembly]

- 1) Remove the four fixing screws to remove the cover from the display unit (NCD-9170).

(A flat tip screwdriver for 6 mm screws)

For standalone type NCD-9170



For desktop type: NDC-1478

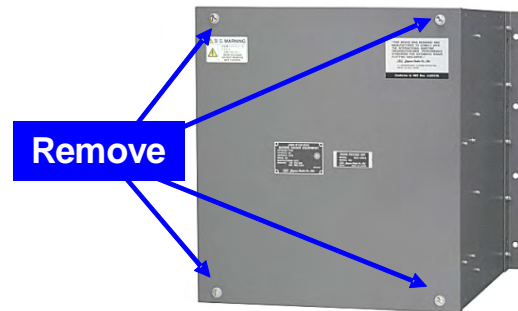

- 2) Remove the cable connected to the radar process circuit board.

The radar process circuit is the first board from the left.

- 3) Remove the two fixing screws (M4).
- 4) Pull out the board to the front.

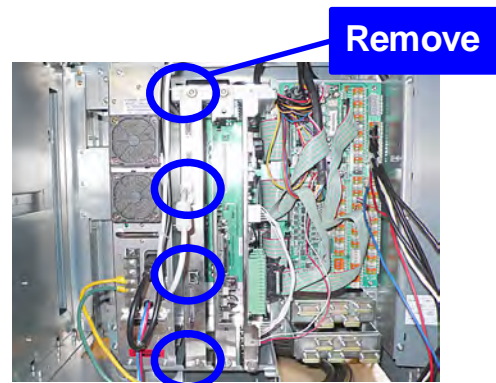

- 5) Insert the flat tip **nonconductive** screwdriver for adjustment or some stick between the battery and the battery holder and lift the battery up.

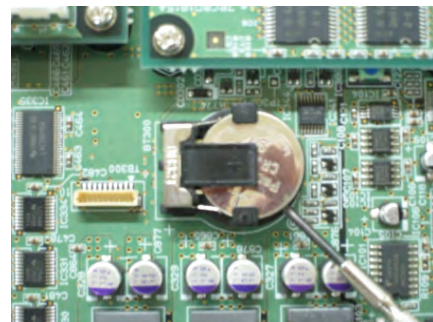

- 6) *Insert the flat tip **nonconductive** screwdriver for adjustment or some stick to the location shown in the figure below and slide the battery sideways to remove the battery.*

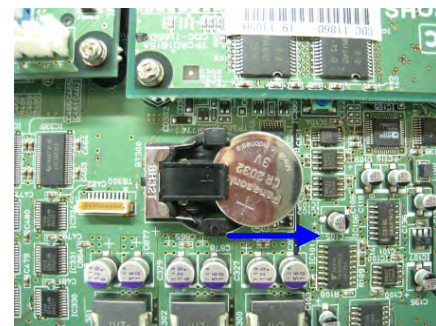
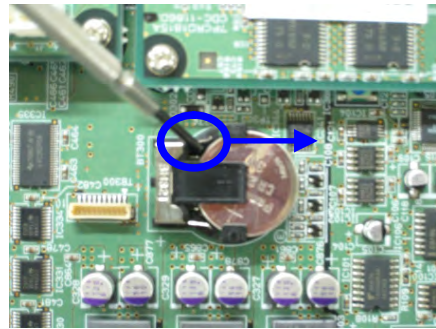

[Assembly]

- 1) *Check the polarity of the battery. Make sure that the battery's positive (+) side is facing up.*
- 2) *Slide the battery sideways into the battery holder.*
- 3) *Make sure that the battery is inserted fully.*

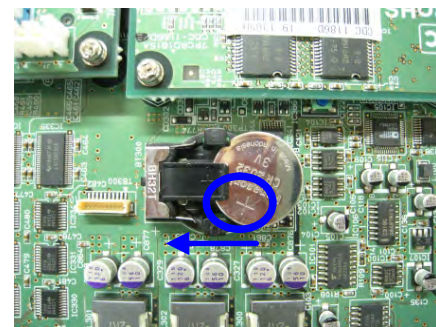

[Check Item]

- 1) *Check that no error message comes up.*
- 2) *Check that the system starts up normally.*

[Notes]



**CAUTION**

If you installed the battery with the wrong polarity, remove the battery immediately and do not use the same battery again.



**CAUTION**

During the procedures, do not put the battery on any circuit board or conductive item.



**CAUTION**

To dispose of a used battery, follow the instructions provided in Section 10.2 "DISPOSAL OF USED BATTERIES".



**CAUTION**

To disassemble of a used battery, have to use non-conductive tool.





# SECTION 9

## TROUBLE SHOOTING AND AFTER-SALES SERVICE

### TROUBLE SHOOTING AND AFTER-SALES SERVICE

9.1	FAULT FINDING .....	9-1
9.1.1	List of Alarms and other Indications .....	9-1
9.1.2	Operation Checking .....	9-6
9.1.3	Fuse Checking .....	9-6
9.2	TROUBLE SHOOTING .....	9-7
9.2.1	Circuit Block to be Repaired .....	9-7
9.3	AFTER-SALES SERVICE .....	9-9
9.3.1	Keeping period of maintenance parts .....	9-9
9.3.2	When you Request for Repair .....	9-9
9.3.3	Recommended Maintenance .....	9-9





# 9.1 FAULT FINDING

In case of semiconductor circuits, it is deemed that there are few cases in which the used semiconductor devices have inferior quality or performance deterioration except due to insufficient design or inspection or by other external and artificial causes. In general, the relatively many causes are disconnection in a high-value resistor due to moisture, a defective variable resistor and poor contact of a switch or relay.

Some troubles are caused by defective parts, imperfect adjustment (such as tuning adjustment) or insufficient service (such as poor cable contact). It will also be effective to check and readjust these points.

## 9.1.1 List of Alarms and other Indications

If any of the following alarm occurs, the system displays the alarm message in red in order to attract the attention of operator. Other messages are displayed with the suitable color which is yellow or blue depending on the level of message importance.

Alarm:	Red	<ul style="list-style-type: none"> <li>• Collision-related Alarm</li> <li>• Navigation Alarm</li> <li>• System Alarm</li> </ul>
Warning:	Yellow	<ul style="list-style-type: none"> <li>• System Warning</li> </ul>
Information:	Blue	<ul style="list-style-type: none"> <li>• Operation Information</li> </ul>

Alarm message is displayed in the lower right of the display. For more details refer to page2-31 Alarm.

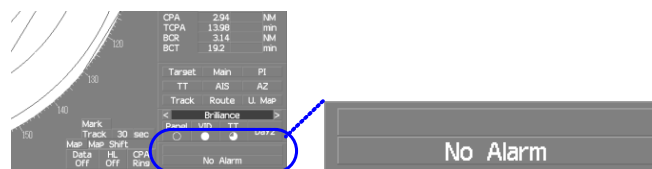

This section gives the list of alarms displayed by the system and other display lists.

Table9-1 : Critical Alarm

Message	Class	Description	ALR No. <sup>i</sup>
CPA/TCPA	Alarm	There is a dangerous target.	301

i. ALR No.: Unique alarm number in ALR sentence and ACK sentence

Table9-2 : List of System Error Message

Message	Class	Description	ALR No. <sup>1</sup>
<b>Autopilot (Data)</b>	Alarm	Autopilot: No communication or data error.	101
<b>Current (Data)</b>	Alarm	Tidal current: No communication or data error.	119
<b>Date (Data)</b>	Alarm	Date data: No communication or data error.	112
<b>Datum (Data)</b>	Alarm	DTM: No communication or data error.	122
<b>Depth (Data)</b>	Alarm	Water depth: No communication or data error.	115
<b>Fan (LCD)</b>	Alarm	LCD monitor: Fan error.	955
<b>Fan (Power)</b>	Alarm	Power Supply: Fan error.	953
<b>Fan (PROC)</b>	Alarm	RADAR Process Unit Interconnection: Fan error.	951
<b>GPS (Status)</b>	Alarm	GPS status error.	103
<b>GYRO I/F (Data)</b>	Alarm	GYRO I/F: No communication or checksum error.	324
<b>GYRO I/F (GYRO)</b>	Alarm	GYRO I/F: GYRO error detected.	110
<b>GYRO I/F (Log)</b>	Alarm	GYRO I/F: Log error detected.	111
<b>Heading (Data)</b>	Alarm	Heading data: No communication or data error.	113
<b>Keyboard (Data)</b>	Alarm	Operation unit: Communication error or checksum error.	325
<b>Keyboard2 (Data)</b>	Alarm	Second operation unit: Communication error or checksum error.	325
<b>Out of Bounds</b>	Alarm	Own ship's latitude is over 85° N or 85° S.	123
<b>Position (Data)</b>	Alarm	Latitude / longitude data: No communication or data error.	102
<b>PROC (AZI)</b>	Alarm	Process unit: AZI error.	305
<b>PROC (HL)</b>	Alarm	Process unit: HL error.	306
<b>PROC (Interrupt)</b>	Alarm	Process unit: Interrupt error.	962
<b>PROC (Trigger)</b>	Alarm	Process unit: Trigger error.	304
<b>PROC (Video)</b>	Alarm	Process unit: VIDEO error.	303
<b>ROT (Data)</b>	Alarm	Rate of Turn: No communication or data error.	120
<b>RSA (Data)</b>	Alarm	Rudder Sensor Angle: No communication or data error.	121
<b>Speed (2AXG)</b>	Alarm	2-axis log (speed over ground): No communication or data error.	114
<b>Speed (2AXW)</b>	Alarm	2-axis log (speed over water): No communication or data error.	114
<b>Speed (GPS)</b>	Alarm	GPS speed: No communication or data error.	114
<b>Speed (Log)</b>	Alarm	1-axis log: No communication or data error.	114
<b>SRB (Data)</b>	Alarm	SRB: No communication or data error.	960
<b>TEMP. (Data)</b>	Alarm	Water temperature: No communication or data error.	117
<b>TXRX (AZI)</b>	Alarm	Scanner: BP error.	311
<b>TXRX (Data)</b>	Alarm	Scanner: No communication, communication mismatched, checksum error, or collision.	326
<b>TXRX (Fan 1)</b>	Alarm	Scanner: FAN 1 error.	
<b>TXRX (Fan 2)</b>	Alarm	Scanner: FAN 2 error.	
<b>TXRX (Fan 3)</b>	Alarm	Scanner: FAN 3 error.	
<b>TXRX (HL)</b>	Alarm	Scanner: HL error.	
<b>TXRX (Lo PLL)</b>	Alarm	Scanner: Local PLL error.	
<b>TXRX (PROC)</b>	Alarm	Radar Processor error	
<b>TXRX (PS)</b>	Alarm	Power Supply error	

Table9-2 : List of System Error Message

Message	Class	Description	ALR No. <sup>i</sup>
<b>TXRX (Reverse)</b>	Alarm	Scanner: Reverse rotation.	
<b>TXRX (SSW Off)</b>	Alarm	Scanner: Safety switch OFF.	
<b>TXRX (Trigger)</b>	Alarm	Scanner: TRIGGER error..	
<b>TXRX (Video)</b>	Alarm	Scanner: VIDEO error.	
<b>Wind (Data)</b>	Alarm	Wind direction/velocity: No communication or data error.	118

i. ALR No.: Unique alarm number in ALR sentence and ACK sentence

Table9-3 : List of Notification

Message	Class	Description	ALR No. <sup>i</sup>
<b>CCRP Changed</b>	INFO	CCRP is automatically changed.	
<b>Copying</b>	INFO	Displayed-image is capturing to file.	
<b>POSN Reset</b>	INFO	Change the latitude and longitude sentence.	
<b>Set GYRO</b>	INFO	Requires setting of true bearing.	
<b>TM Reset</b>	INFO	Resetting TM in a short time.	

i. ALR No.: Unique alarm number in ALR sentence and ACK sentence

Table9-4 : List of Target Tracking Alarms and AIS Function Alarms

Message	Class	Description	ALR No. <sup>i</sup>
<b>AIS (Data)</b>	Alarm	AIS: No communication or communication error.	116
<b>AIS 95% Capacity</b>	INFO	Over 95% of the maximum number of AIS targets.	
<b>AIS ACT 95% Capacity</b>	INFO	Over 95% of the maximum number of AIS targets to be activated.	
<b>AIS ACT MAX</b>	INFO	Maximum number of AIS targets to be activated.	
<b>AIS Alarm ***ii</b>	Alarm	AIS alarm (Up to 10 alarm messages can be displayed.).	
<b>AIS Max Target</b>	INFO	Maximum number of AIS targets.	
<b>AIS PROC (Data)</b>	Alarm	AIS processing circuit: No communication or communication error.	328
<b>CPA/TCPA</b>	Alarm	There is a dangerous target.	301
<b>Lost</b>	Alarm	Failure in tracking the target that has been under tracking. Failure in receiving AIS target data for a specified time.	
<b>New Target</b>	Alarm	Acquisition or activation of a target in the automatic acquisition / activation zone.	302
<b>REF Target</b>	Alarm	Decrease in the reference target accuracy.	
<b>Trial</b>	Warning	There is a dangerous target, when trial maneuver is active.	
<b>TT (Boot)</b>	Alarm	Target tracking unit start failure.	344
<b>TT (Data)</b>	Alarm	The target tracking unit is malfunctioning.	323
<b>TT 95% Capacity</b>	INFO	Over 95% of the maximum number of targets to be tracked.	
<b>TT MAX Target</b>	INFO	The maximum number of targets is under acquisition.	

i. ALR No.: Unique alarm number in ALR sentence and ACK sentence

ii. \*\*\* is a 3-digit number which is Local Alarm No in the ALR sentence.

Table9-5 : List of Route Messages and Warnings

Message	Class	Description	ALR No. <sup>1</sup>
<b>Approach</b>	Alarm	Approach the route.	
<b>Arrival</b>	Alarm	Arrive at way point.	
<b>Break Off(WPT)</b>	Alarm	Out of the way point.	
<b>Cross Track Error</b>	Alarm	Go off the route.	

i. ALR No.: Unique alarm number in ALR sentence and ACK sentence

Table9-6 : List of Operational Alarm Messages and Warnings

Message	Class	Description	ALR No. <sup>1</sup>
<b>Can't Transmit</b>	INFO	Tried to transmit within 5 second after standby or when the transmitter-receiver has any trouble.	
<b>Card Full</b>	INFO	Card: Run out of free space.	
<b>Copy Failed</b>	INFO	Card: Copy failure.	
<b>Delete Failed</b>	INFO	Card: Deletion failure.	
<b>Format Card</b>	INFO	Card: Unformatted card.	
<b>Format Failed</b>	INFO	Card: Format failure.	
<b>Invalid Card</b>	INFO	Card: Invalid card.	
<b>Invalid Connection</b>	INFO	The operator set performance monitor to on without selecting straight.	
<b>Invalid Data</b>	INFO	Tried to enter any data beyond its range.	
<b>Invalid Range</b>	INFO	TM selection due to TM-disabled range (96 nm). Zooming in a ZOOM-disabled range (0.125 nm).	
<b>MAX Point</b>	INFO	Tried to enter navigation information beyond the specified.	
<b>No Card</b>	INFO	Card not detected yet.	
<b>No Heading Data</b>	INFO	Target tracking operation or TM selection when bearing data is invalid.	
<b>No Object</b>	INFO	No object at the cursor-specified position.	
<b>No Position Data</b>	INFO	Mark or line input when the latitude and longitude is invalid.	
<b>Not Allowed</b>	INFO	General operation error.	
<b>Out of Range</b>	INFO	Out of target acquisition range.	
<b>Read Failed</b>	INFO	Card: Read failure.	
<b>Slave Mode</b>	INFO	Operation of a menu for the scanner unit when the slave mode is active.	
<b>Write Failed</b>	INFO	Card: Write failure.	

i. ALR No.: Unique alarm number in ALR sentence and ACK sentence

Table9-7 : List of Conditions Messages

Message	Class	Description	ALR No. <sup>i</sup>
<b>Battery Dead</b>	Warning	The battery is dead.	
<b>Battery Low</b>	Warning	battery is weakening.	
<b>GPS (HDOP)</b>	Warning	The HDOP level is increased (Decrease in the GPS accuracy.).	
<b>MON Test</b>	Warning	Performance monitor is active.	
<b>Scanner Rotating</b>	Warning	The scanner is rotating (When transmitter is standby state.).	

i. ALR No.: Unique alarm number in ALR sentence and ACK sentence

Table9-8 : List of Interswitch Alarms and Messages

Message	Class	Description	ALR No. <sup>i</sup>
<b>Connection Masked</b>	INFO	Inhibition of control / connection is set.	
<b>ISW (Data)</b>	Alarm	No communication, data mismatched, or checksum error.	327
<b>ISW Busy</b>	INFO	Access to the ISW menu was made during interswitching.	
<b>ISW Complete</b>	INFO	The switchover of the Interswitch ended normally.	
<b>ISW Error</b>	INFO	The interswitch is disabled.	
<b>ISW Standby</b>	INFO	The Interswitch recovered normally.	
<b>ISW Straight</b>	INFO	The interswitch is forced to change the connection into straight.	
<b>ISW Time Out</b>	INFO	Failed in switching.	
<b>Master Range CHG</b>	INFO	The range of the own display unit has changed due to change in the range of the master display unit.	
<b>Master Standby</b>	INFO	The master display unit does not transmit any signals.	
<b>Pattern CHG Failed</b>	INFO	Connection change failed.	
<b>TXRX Standby</b>	INFO	The scanner unit is in the standby mode.	
<b>Update ISW Software</b>	INFO	Tried to enter new TXRX function, when interswitch software used old version.	

i. ALR No.: Unique alarm number in ALR sentence and ACK sentence

**Note: Interswitch is un-available for evaluation model.**

### 9.1.2 Operation Checking

When the system is operating, the operation status (located at the upper right of the screen) is changing pictures.

If picture freeze occurred, turn off the system and restart the system.

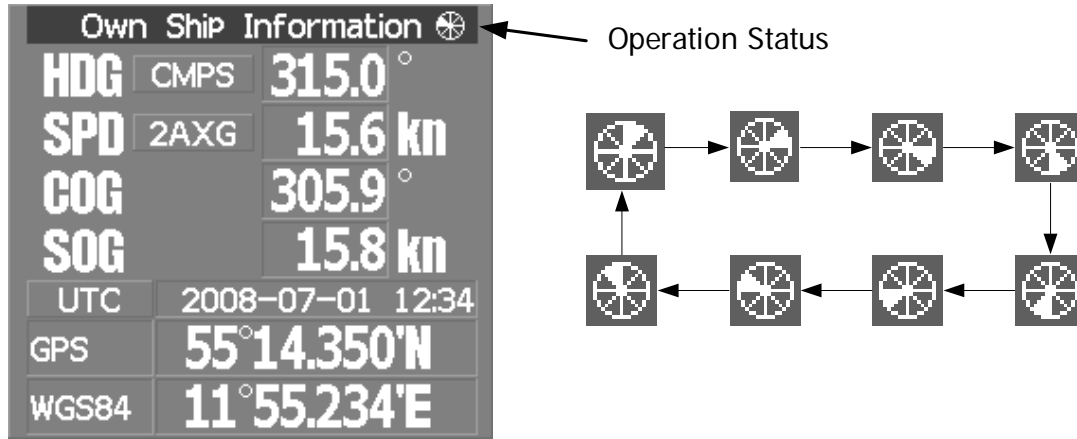

### 9.1.3 Fuse Checking

Melted fuses are caused by any clear cause. When a fuse is replaced, it is necessary to check the related circuits even if there is no trouble. In checking, note that there is some dispersion in the fusing characteristics. Table 9-8 shows a list of fuses used in the equipment.

Table9-9 : Fuse List

Location	Parts#	Current Rating	Protection Circuit	Type
AC/DC Converter	F501	10A	Motor	ST6-10AN1
GYRO Interface circuit	F1 ~ F4	0.5A	GYRO Interface circuit	MF60NR250V0.5

# 9.2 TROUBLE SHOOTING

As this radar equipment includes complicated circuits, it is necessary to request a specialist engineer for repair or instructions for remedy if any circuit is defective.

There are also troubles by the following causes, which should be referred to in checking or repair work.

## 1 Poor Contact in Terminal Board of Inter-Unit Cables

- a. Poor contact in terminal board
- b. The cable end is not fully connected, that it, contacted with earthed another terminal.
- c. Disconnected cable wire

## 2 Poor Contact of Connector within Unit



 This radar equipment is provided with Table 9-10 standard spares.

Table9-10 : 7ZXRD0025

Name	Type/Code	Shape (mm)	In use	Spare	Parts #	Location
Fuse	MF60NR250V0.5 (5ZFGD00006)		4	12	F1 ~ F4	GYRO Interface Circuit CMJ-462E
Fuse	ST6-10AN1 (5ZFCA00053)		1	3	F501	AC/DC Converter NBA-5135

### 9.2.1 Circuit Block to be Repaired

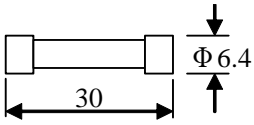

Table9-11 : Circuit Block to be Repaired (JMA-9172-SA)

Location	Circuit Block	Type	Remarks
SCANNER UNIT	MOTOR	H-7BDRD0049 <sup>*i</sup>	DC brushless motor
SCANNER UNIT	AC220V MOTOR DRIVER	CBD-2010	
SCANNER UNIT	AC100V MOTOR DRIVER	CBD-2011	
SCANNER UNIT	BRAKE CIRCUIT	CFA-1255	
SCANNER UNIT	BRAKE CIRCUIT A	CFA-1261	
SCANNER UNIT	BRAKE CIRCUIT B	CFA-1262	
SCANNER UNIT	BRAKE CONTROL CIRCUIT	CCB-1655	
SCANNER UNIT	ENCODER	CHT-1071	
SCANNER UNIT	IF INPUT/OUTPUT CIRCUIT	CHA-396	
SCANNER UNIT	INTERFACE CIRCUIT	CMH-2246	
SCANNER UNIT	PERFORMANCE MONITOR	CAY-71	
SCANNER UNIT	POWER SUPPLY CIRCUIT	CBD-1798	
SCANNER UNIT	RADAR PROCESS CIRCUIT	CDC-1349	
SCANNER UNIT	RELAY FILTER CIRCUIT	CSC-1656	
RADAR PROCESS UNIT	RADAR PROCESS CIRCUIT	MPBC44213*	CDC-1362 with mounting bracket, CDC-1363 and CDC-1186D
RADAR PROCESS UNIT	RADAR PROCESS CIRCUIT	MDLW11900*	CDC-1362 with mounting bracket
RADAR PROCESS UNIT	AIS PROCESS CIRCUIT	CDC-1363	
RADAR PROCESS UNIT	ARPA PROCESS CIRCUIT	CDC-1364	
RADAR PROCESS UNIT	GYRO INTERFACE CIRCUIT	CMJ-523	
RADAR PROCESS UNIT	TERMINAL BOARD	CQD-2176	
RADAR PROCESS UNIT	MOTHER BOARD	CQC-1230	
RADAR PROCESS UNIT	FAN (RPU)	109R0612S4D13	
RADAR PROCESS UNIT	POWER SUPPLY	CBD-1861	
RADAR PROCESS UNIT	FAN (PSU)	H-7BFRD0006*	
OPERATION UNIT	OPERATION CIRCUIT A	CCK-1005	
OPERATION UNIT	OPERATION CIRCUIT B	CCK-1006	
OPERATION UNIT	OPERATION CIRCUIT D	CCK-1007	
OPERATION UNIT	TRACKBALL	CCK-1013	
MONITOR UNIT	BEZEL KIT	MPXP34376*	Radar bezel kit
MONITOR UNIT	23 inch LCD	CML-799	23.1-inch LCD PANEL
MONITOR UNIT	LCD OPERATION CIRCUIT	CCK-1004	

i. “\*” means revision, such as A, B and so on.

## 9.3 AFTER-SALES SERVICE

### 9.3.1 Keeping period of maintenance parts

Keeping period of maintenance parts is ten years from the production is discontinued.

### 9.3.2 When you Request for Repair

If you suppose the product may be out of order, read the description in Section 9 carefully and check the suspected point again.

If it is still out of order, you are recommended to stop operation of the equipment and consult with the dealer from whom you purchased the product, or our branch office in your country or district, the sales department in our main office in Tokyo.

#### Repair within the Warranty Period

If any failure occurs in the product during its normal operation in accordance with the instruction manual, the dealer or JRC will repair free of charge. In case that any failure is caused due to misuse, faulty operation, negligence or force major such as natural disaster and fire, the product will be repaired with charges.

#### Repair after the Warranty Period

If any defective function of the product is recoverable by repair, the repair of it will be made at your own charge upon your request.

#### Necessary Information for Repair

- Product name, model, manufacturing date and serial number
- Trouble conditions (as detailed as possible. Refer to "Radar Failure Check List" on page 9-10)
- Name of company/organization, address and telephone number

### 9.3.3 Recommended Maintenance

The performance of the product may deteriorate due to the secular change of the parts used in it, though such deterioration depends upon the conditions of operation. So checkup and maintenance is recommendable for the product in addition to your daily care.

For maintenance, consult with the near-by dealer or our sales department. Such maintenance will be made with charges.

For further details of after-sale service, contact the JRC Offices.

## Radar Failure Check List



When placing an order for repair of the product, it is requested that you could confirm the check items and fill the results and sent the sheet to our contact. If there is any unclear items, contact the ship on which the product is installed, and give the correct information on the product.

Ship name: \_\_\_\_\_ Phone: \_\_\_\_\_ Fax: \_\_\_\_\_

<sup>i</sup> Radar general model name: JMA- \_\_\_\_\_ <sup>i</sup>Serial No. : \_\_\_\_\_

i. Write the full model name correctly

Check the following items in the order of the number, and check the applicable answer between YES or NO.

If the item cannot be determined as YES or NO, explain in detail in the item (16), others.

No.	Check Item	Result	
(1)	Power can be turned on. (The lamp on the Operation unit is lit)	YES	NO
(2) <sup>i</sup>	A few minutes after powering-on, it will become standby status.	YES	NO
(3) <sup>i</sup>	When powering-on (or TX ON), LCD monitor something is lit.	YES	NO
(4) <sup>i,ii</sup>		YES	NO
(5) <sup>ii</sup>	Fixed marker is displayed.	YES	NO
(6) <sup>ii</sup>	VRM is displayed.	YES	NO
(7) <sup>ii</sup>	While noise is displayed while set at SEA and RAIN minimum, GAIN maximum, IR-OFF and range 48 NM.	YES	NO
(8) <sup>ii</sup>	Target reflection echo is displayed.	YES	NO
(9) <sup>ii</sup>	Sensitivity of reflection echo is normal.	YES	NO
(10) <sup>ii</sup>	EBL is displayed.	YES	NO
(11) <sup>ii</sup>	Cursor mark moves.	YES	NO
(12) <sup>ii,ii</sup>	GYRO course can be set and normally displayed.	YES	NO
(13) <sup>ii,iii</sup>	LOG speed can be normally displayed.	YES	NO
(14) <sup>ii</sup>	Target tracking function works normally.	YES	NO
(15) <sup>ii,iii</sup>	If equipped with an interswitch, when switching from the straight mode (II) to (X), the failures (items marked NO) in the above (1) to (14), are switched over to the other unit.	YES	NO
(16)	Others (Error message, etc. )		

i. If result is NO, then check the fuse. (Refer to Section 9.1.2 "Operation Checking" and Section 9.2 "TROUBLE SHOOTING")

ii. Check these items at transmission.

iii. Functions mentioned in the items (12), (13) and (15) may be optional, answer is not necessary.

# SECTION 10 DISPOSAL

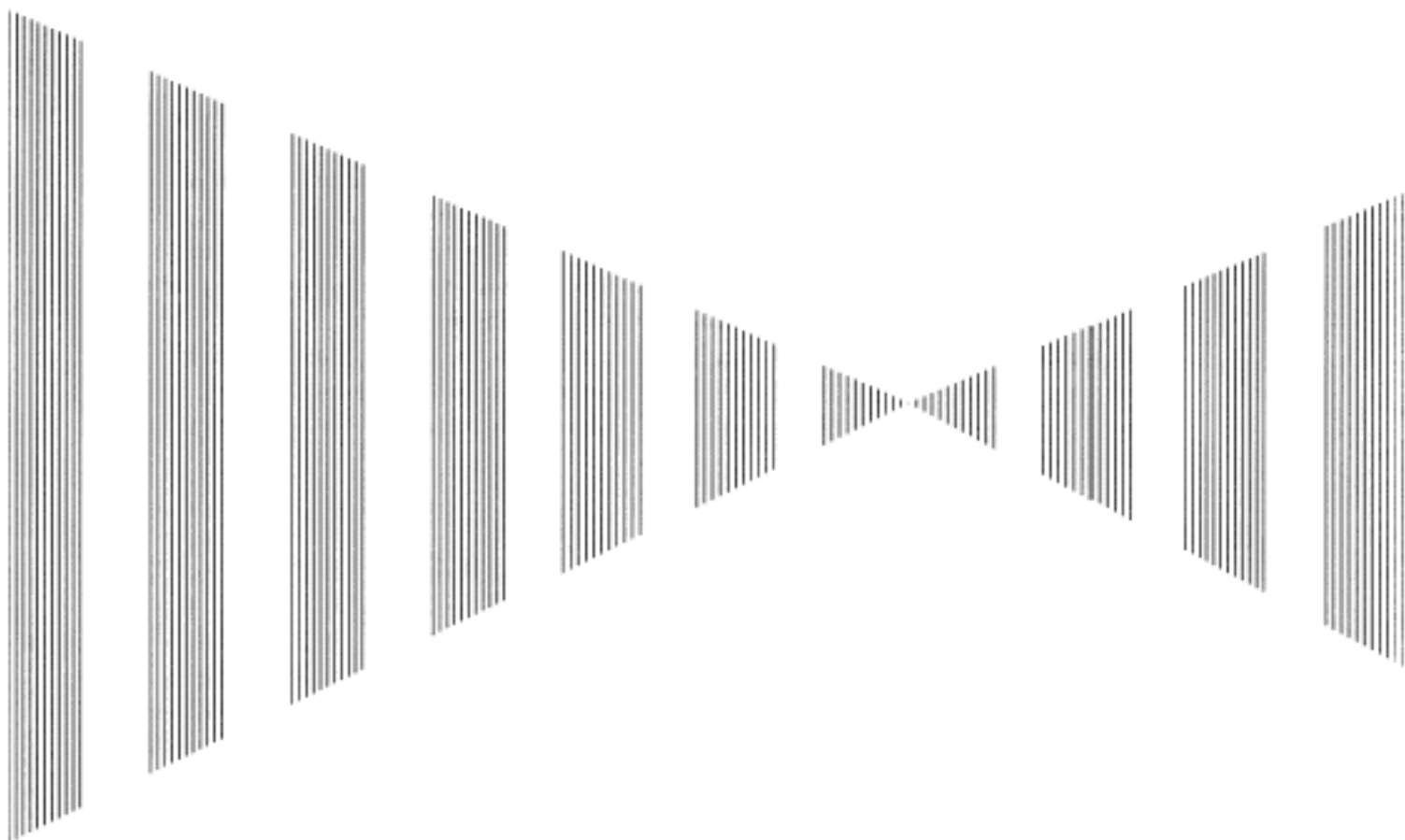

## DISPOSAL

10.1	DISPOSAL OF THE UNIT .....	10-1
10.2	DISPOSAL OF USED BATTERIES .....	10-1
10.3	ABOUT THE CHINA ROHS .....	10-2



## 10.1 DISPOSAL OF THE UNIT

When disposing of this unit, be sure to follow the local laws and regulations for the place of disposal.

## 10.2 DISPOSAL OF USED BATTERIES



### WARNING



**When disposing of used lithium batteries, be sure to insulate the batteries by taping the  $\oplus\ominus$  terminals.**

**Otherwise, heat generation, explosion or a fire may occur.**

In this unit, Lithium batteries are used for the following parts:

Radar Processing circuit (CDC-1362): BT300 (Maxell: CR2032)

- Do not store used lithium batteries. Dispose of them in accordance with regulations of local government.
- When disposing of used lithium batteries be sure to insulate the batteries by taping the  $\oplus\ominus$  terminals. For disposal of batteries, be sure to follow the local laws and regulations. For detail, consult with the dealer you purchased the product our business office, or local government.

# 10.3 ABOUT THE CHINA ROHS

## 有毒有害物质或元素的名称及含量

(Names & Content of toxic and hazardous substances or elements)

形式名(Type): JMA-9100 Series, JMA-7100Series

名称(Name): RADAR

部件名称 (Part name)	有毒有害物质或元素 (Toxic and Hazardous Substances and Elements)					
	铅 (Pb)	汞 (Hg)	镉 (Cd)	六价铬 (Cr6+)	多溴联苯 (PBB)	多溴二苯醚 (PBDE)
雷达天线单元 (Scanner Unit)	×	×	○	×	×	×
收发信单元 (Transmitter-receiver Unit)	×	×	×	×	×	×
主船内装置 (Inboard Unit) · 显示装置 (Display Unit) · 键盘装置 (OperationUnit) · 信号处理装置 (RADAR Process Unit)	×	×	×	×	×	×
外部设备 (Peripherals) · 选择 (Options) · 电线类 (Cables) · 手册 (Documennts)	×	×	×	×	×	×
<p>○: 表示该有毒有害物质在该部件所有均质材料中的含量均在SJ/T11306-2006 标准规定的限量要求以下。 (Indicates that this toxic, or hazardous substance contained in all of the homogeneous materials for this part is below the requirement in SJ/T11363-2006.)</p> <p>×: 表示该有毒有害物质至少在该部件的某一均质材料中的含量超出SJ/T11363-2006 标准规定的限量要求。 (Indicates that this toxic or hazardous substance contained in at least one of the homogeneous materials used for this part is above the limit requirement in SJ/T 11363-2006.)</p>						

# SECTION 11 SPECIFICATION

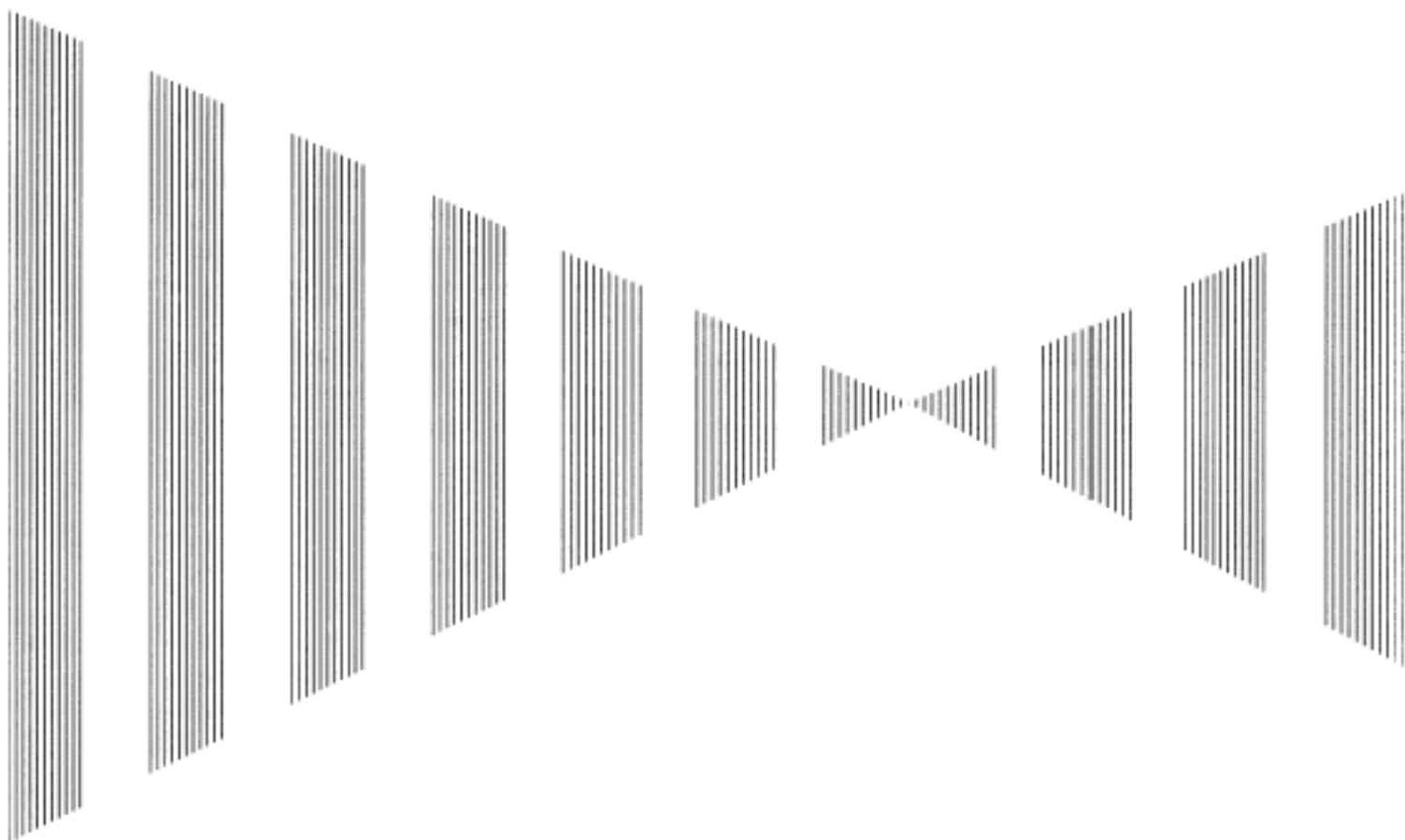

## SPECIFICATION

11.1	JMA-9172-SA TYPE RADAR .....	11-1
11.2	SCANNER UNIT (NKE-1139) .....	11-2
11.3	DISPLAY UNIT (NCD-4990) .....	11-3
11.4	Target Tracking Function .....	11-6
11.5	AIS FUNCTION .....	11-7





# 11.1

## JMA-9172-SA TYPE RADAR

### GENERAL SPECIFICATION

Class of emission	P0N, Q0N
Display	Color Raster Scan
Screen	23.1inch LCD (Effective diameter of Radar: more than 320mm)
Range Scale	0.125, 0.25, 0.5, 0.75, 1.5, 3, 6, 12, 24, 48, 96NM
Range Resolution	less than 30m
Minimum Detection Range	less than 40m
Bearing Accuracy	less than 1°
Bearing Indication	Relative motion mode : N-UP, C-UP and H-UP True motion mode : N-UP and C-UP
Ambient Condition	Temperature SCANNER UNIT -25 to +55°C (Storage -25 to +70°C) Other Unit -15 to +55°C Relative humidity 93% at +40°C
Vibration	2 to 13.2Hz Amplitude +/-1mm +/-10% 13.2 to 100Hz Acceleration 7m/s <sup>2</sup>
Power Supply Input	AC100 to 115V, 50/60Hz, 1φ or AC220 to 240V, 50/60Hz, 1φ
Power Consumption	Approx.600VA typical Approx. 2200VA at Maximum wind speed
PS Voltage Fluctuation	+/-10% (at the maximum cable length)
Pre Heating Time	Within10 sec
From STBY to TX	Within 5 sec.
<b>SCANNER UNIT (NKE-1532)</b>	
	See 11.2
<b>DISPLAY UNIT (NCD-9170)</b>	
	See 11.3
<b>OPTION</b>	
Scanner with Deicing Heater	NKE-1532-D (Only heater collar)
DISPLAY UNIT (Desktop type)	NCD-9170T
<b>Maximum Cable Length</b>	
SCANNER UNIT to TRANSMITTER RECEIVER UNIT	65m
<b>SAFE DISTANCE FOR STANDARD COMPASS</b>	
SCANNER UNIT	5.1m
DISPLAY UNIT	4.0m

# 11.2 SCANNER UNIT (NKE-1532)

## SCANNER UNIT NKE-1130

Dimension	Height 791 x Swing Circle 4000 (mm)																		
Mass	Approx.170kg																		
Polarization	Horizontal																		
Directional Characteristics	Horizontal beam width : 1.9° Vertical beam width : 25° Side lobe Level : below -26dB (within +/-10°) : below -30dB (outside +/-10°)																		
Revolution	Approx.24rpm																		
Power Supply for Motor	AC100 - 115V、50/60Hz、1φ or AC220 - 240V、50/60Hz、1φ																		
Maximum Wind Velocity	51.5m/s (100knots)																		
Transmitting Frequency	P0N(3040MHz), Q0N(3060MHz ± 4MHz)																		
Transmitting Power	300W (+25/-50%)																		
Transmitter	Solid State Power Amplifier																		
TX Pulse width (1st) / TX Pulse width, Frequency Deviation Width (2nd) / Repetition Frequency	SP1 : 0.07 μs / 4.6 μs, 8MHz / 1860Hz or 2280Hz *i MP1 : 0.14 μs / 9.1 μs, 8MHz / 1860Hz or 2280Hz *i MP2 : 0.29 μs / 9.1 μs, 8MHz / 1860Hz or 2280Hz *i LP1 : 0.57 μs / 9.1 μs, 8MHz / 1280Hz LP2 : 1.14 μs / 18.3 μs, 8MHz / 640Hz																		
	<table border="1"> <tr> <td>0.125、0.25、0.5NM</td> <td>: SP1</td> </tr> <tr> <td>0.75NM</td> <td>: SP1/MP1</td> </tr> <tr> <td>1.5NM</td> <td>: SP1/MP1/MP2</td> </tr> <tr> <td>3NM</td> <td>: SP1/MP1/MP2/LP1/LP2</td> </tr> <tr> <td>6NM</td> <td>: MP1/MP2/LP1/LP2</td> </tr> <tr> <td>12NM</td> <td>: MP2/LP1/LP2</td> </tr> <tr> <td>24NM</td> <td>: LP1/LP2</td> </tr> <tr> <td>48NM</td> <td>: LP2</td> </tr> <tr> <td>96NM</td> <td>: LP2</td> </tr> </table>	0.125、0.25、0.5NM	: SP1	0.75NM	: SP1/MP1	1.5NM	: SP1/MP1/MP2	3NM	: SP1/MP1/MP2/LP1/LP2	6NM	: MP1/MP2/LP1/LP2	12NM	: MP2/LP1/LP2	24NM	: LP1/LP2	48NM	: LP2	96NM	: LP2
0.125、0.25、0.5NM	: SP1																		
0.75NM	: SP1/MP1																		
1.5NM	: SP1/MP1/MP2																		
3NM	: SP1/MP1/MP2/LP1/LP2																		
6NM	: MP1/MP2/LP1/LP2																		
12NM	: MP2/LP1/LP2																		
24NM	: LP1/LP2																		
48NM	: LP2																		
96NM	: LP2																		
Duplexer	Circulator + Diode Limiter																		
Front End Module	Built-in																		
Intermediate Frequency Amplifier	Intermediate Frequency : 63MHz Band Width : 30MHz Gain : more than 50dB Amplifying Characteristics : Linear Amplifier																		
Overall Noise Figure	within 4.0dB ( Typical)																		

\*i: PRF setting is "Normal" : 1860Hz  
PRF setting is "High Power" : 2280Hz Refer to [Appendix 3.8.3.2](#)

# 11.3 DISPLAY UNIT (NCD-9170)

## DISPLAY UNIT NCD-9170

Dimension	Width 700 x Depth 850 x Height 1100 (mm)	
Structure	Self-Standing, Drip Proof	
Mass	Approx.130kg	
Screen	23.1inch Color LCD (Effective Diameter, more than 320mm)	
Viewing Distance	1m from the center of Display	
Range Scale	0.125, 0.25, 0.5, 0.75, 1.5, 3, 6, 12, 24, 48, 96NM	
Range Marker	0.025, 0.05, 0.1, 0.25, 0.25, 0.5, 1, 2, 4, 8, 16NM	
Range Accuracy	Less than 1% of the Range Scale in use, or 30m whichever is larger	
Variable Range Marker	2 (VRM1/VRM2)	
VRM Scale	0.000 to 100.0nm, Numerical Indication in 4 digits	
Bearing Scale	360° in 1° step	
Off Center	Within 66% of Radius, except 96nm range	
Trackball Cursor	Built-in (Target Range, Relative/True bearing Presentation)	
Electronic Bearing Lines	2 (EBL1/EBL2) (on Center/Floating)	
EBLBearing Indication	000.0° to 359.9° Numerical Indication in 4 digits	
Marking Function	Electronic Mark (Maximum 20 points)	
Heading Line Indication	Electronic	
True Motion Unit	Built in (0.25, 0.5, 0.75, 1.5, 3, 6, 12, 24 and 48nm)	
Anti Sea Clutter (SEA)	Manual/AUTO	
Anti Rain Clutter (SEA)	Manual/AUTO	
Display mode	North-up / Head-up / Course-up	
Trails Indication	Off/0.25/0.5/1/3/6/10/15/30/60min	
Video Process (PROC)	Built in (Scan correlation / Remain)	
Interference Rejection (IR)	Built in ( Off / Low / Middle / High)	
Auto-acquisition Zone (AZ)	Sector (2)	
User Map <sup>i</sup>	Built in, Mark and Line (20,000 points)	
Self diagnostic function	Built in	
Own Ship's Track Indication <sup>i</sup>	Built in	
Parallel Index Line (PI)	Built in	
AIS Indication	Built in	Display 300 Activate 100 Association function:Built in
Interfacing	Slave Display (TRG, VD, BP, BZ) GPS IEC61162-1(NMEA0183) LOG GYRO AIS IEC61162-2 Radar Buoy External Alarm output	

## Receivable Signal<sup>iii</sup>

Receive capability Port:	NAV1/NAV2/LOG/ALM/AIS/HDG at TB4501 COM DSub-9pin	
Navigation equipment IEC61162-1/2	Longitude/Latitude	GGA>RMC>RMA>GNS>GLL
	Waypoint	RMB>BWC(BWR)
	COG/SOG	RMC > RMA > VTG
	SPEED	VBW
	Day/Time information	ZDA
	Alarm acknowledge	ACK
	Rate of Turn	ROT
	Rudder	RSA
Bearing signal	GYRO-SYNC	360x, 180x, 90x, 36x(GYRO I/F)
	GYRO-STEP	360x, 180x, 90x, 36x(GYRO I/F)
	IEC61162-2 38400bps	THS>HDT over 40Hz (HDG port at terminal board TB4501)
	IEC61162-1 <sup>iii</sup>	HDT>HDG>HDM>VHW (HDG port at terminal board TB4501)
Speed signal	LOG-SYNC	360x, 180x, 90x, 30x(GYRO I/F)
	LOG-PULSE	800, 400, 200, 100(GYRO I/F)
External event mark	Contact input (EVENT port at terminal board TB4601)	
Radar buoy	Negative input (RBVD port at terminal board TB4401)	
Depth	IEC61162-1/JRC	DPT>DBS>DBT>DBK, JRC format
Water temperature	IEC61162-1/JRC	MTW, JRC format
Tendency	IEC61162-1/JRC	CUR, JRC format
Wind	IEC61162-1	MWV>MWD
AIS	IEC61162-2	VDM,VDO (AIS port at terminal board TB4601 )
Acknowledge	Contact input (SYSACK, ARPAACK, PWRACK port at terminal board TB4601)	
<b>Sendable Signal</b>		
Slave video	Radar video: TIY, VD, BP(2048p), BZ (Terminal board TB4401)	
Send capability Port	NAV1/NAV2/ALM/ARPA/JARPA port at TB4501 MNT port at TB4601 COM at DSub-9pin	
Navigation information IEC61162-1/2	Radar system data	RSD
	Own ship data	OSD
	Tracking target data	TTM,TLL,TTD,TLB,JRC-ARPA
	AIS target data	TTM,TLL,TTD,TLB
	Alarm	ALR
	Auto pilot	APB
	Bearing of destination	BOD
	Latitude/Longitude data	GGA, GLL,RMC
	Waypoint	RMB,BWC
	COG/SOG	VTG
	Cross track error	XTE
	Heading data	HDT,THS

External alarm	Default setting	normally closed contact
	Maximum current	200mA (SYSALM, ALPAALM, PWRALM port at terminal board TB4601)
Acknowledge	Contact output (ACKOUT port at terminal board TB4401)	
Watchman reset	Contact output (WMRST port at terminal board TB4401)	
Remote maintenance	JRC format (MNT port at terminal board TB4601)	
AIS alarm acknowledge	ACK (AIS port at terminal board TB4601)	
External monitor	Multi scan monitor	Analog RGB, HD15pin Connector 2 port

- i. Only with Navigation Equipment is connected.
- ii. The Speed measuring accuracy of speed sensor shall confirm to IMO Resolution MSC.96(72).  
The measuring accuracy of GPS shall confirm to IMO Resolution MSC.112(73).
- iii. Can't be use for target tracking.

# 11.4 Target Tracking Function

Target Tracking Function																
Available range scale	All range															
Acquisition	Acquisition mode	Manual/AUTO (AUTO mode uses Auto-acquisition Zone)														
	Manual Cancellation	Any one Target or All targets at once														
	Acquisition Range	0.1nm - 24nm/32nm <sup>*i</sup> (Available all range scale)														
Tracking	Number of Target	100 Targets (AUTO Tracking)														
	Tracking range	0.1nm - 24nm/32nm <sup>*i</sup> (Available all range scale)														
Presentation	Display mode	TM (True Motion) / RM (Relative Motion)														
	Azimuth mode	North-up / Head-up / Course-up														
	Vector mode	True/Relative Display														
	Vector Length	Variable, 1 to 60 min. (1min. step)														
	Past Position	True/Relative Display Number of Dots...10 points Display Interval Time...0.5 / 1 / 2 / 4 min														
	Time to Display Vector Time to Stabilize Vector	Within 1min Within 3min														
Alarm	Auto-acquisition Zone	2 (sector)														
	Setting Range	AZ1 (0.5 ~ 32nm), AZ2 (0.5 ~ 32nm)														
	Alarm Indication	Symbol on Display, Visible / Audible Alarm														
Safe Limits (CPA / TCPA)	Setting Condition	CPA LIMIT      0.1 to 9.9NM TCPA LIMIT      1 to 99 minute														
	Setting Condition	<table border="1"> <tr> <td rowspan="3">Safe Target</td> <td>CPA &gt; CPA LIMIT</td> </tr> <tr> <td>0 &gt; TCPA</td> </tr> <tr> <td>TCPA &gt; TCPA LIMIT</td> </tr> <tr> <td rowspan="2">Danger Target</td> <td>CPA ≤ CPA LIMIT</td> </tr> <tr> <td>0 ≤ TCPA ≤ TCPA LIMIT</td> </tr> </table>	Safe Target	CPA > CPA LIMIT	0 > TCPA	TCPA > TCPA LIMIT	Danger Target	CPA ≤ CPA LIMIT	0 ≤ TCPA ≤ TCPA LIMIT							
Safe Target	CPA > CPA LIMIT															
	0 > TCPA															
	TCPA > TCPA LIMIT															
Danger Target	CPA ≤ CPA LIMIT															
	0 ≤ TCPA ≤ TCPA LIMIT															
Alarm Indication	<table border="1"> <thead> <tr> <th>Status</th> <th>Symbol</th> <th>Alarm</th> <th>Audible</th> </tr> </thead> <tbody> <tr> <td>Safe Target</td> <td>○ (wht)</td> <td>OFF</td> <td>OFF</td> </tr> <tr> <td>Danger Target</td> <td>○ (red)</td> <td>CPA/TCPA</td> <td>ON</td> </tr> </tbody> </table>				Status	Symbol	Alarm	Audible	Safe Target	○ (wht)	OFF	OFF	Danger Target	○ (red)	CPA/TCPA	ON
	Status	Symbol	Alarm	Audible												
	Safe Target	○ (wht)	OFF	OFF												
Danger Target	○ (red)	CPA/TCPA	ON													
Lost Target	Symbol on Display Visible / Audible Alarm															
Data Indication	Target Data	Simultaneous and Continuous Display for 4 Targets True Bearing, Range, True Course, True Speed, CPA, TCPA, BCR, BCT														
	Own Ship's Data	Course and Speed														
Trial Maneuver	Manual Setting															
	Trial Course	0° to 359.9°														
	Trial Speed	0 to 100 kn														
Accuracy of Display	Complied with IMO Requirement															
System Failure Alarm	Visible / Audible Alarm															
Speed Input	Manual/AUTO (LOG)															

\*i: PRF setting is "Normal" : 32 nm.

PRF setting is "High Power" : 24 nm.

Refer to [Appendix 3.8.3.2](#)

# 11.5 AIS FUNCTION

AIS Function			
Available range scale	All range		
Activation	Activation mode	Manual/AUTO (AUTO mode uses Auto-activation Zone)	
	Manual Cancellation	Any one Target	
Presentation	Number of Activated Target	100 Targets	
	Number of Target	300 Targets (sleeping target and activated target)	
	Past Position	True/Relative Display	
		Number of Dots...10 points	
		Display Interval Time...0.5 / 1 / 2/ 4 min	
		Display Interval distance...0.1 / 0.2 / 0.5/ 1 NM	
	Message	Broadcast Message, Addressed Message	
	Display mode	TM (True Motion) / RM (Relative Motion)	
	Azimuth mode	North-up / Head-up / Course-up	
	Vector mode	True/Relative Display	
	Vector Length	Variable, 1 to 60 min. (1min. step)	
Alarm	Auto-activation Zone	2 (Sector)	
	Setting Range	AZ1(0.5 to 32nm), AZ2(0.5 to 32nm) * 3.8.3.3 PRF setting "Normal" AZ1(0.5 to 32nm), AZ2(0.5 to 32nm) * 3.8.3.3 PRF setting "High Power"	
	Alarm Indication	Symbol on Display, Visible / Audible Alarm	
Safe Limits (CPA / TCPA)	Setting Condition	CPA LIMIT	0.1 to 9.9NM
		TCPA LIMIT	1 to 99min
Alarm Condition	Safe Target	CPA > CPA LIMIT	
		0 > TCPA TCPA > TCPA LIMIT	
	Danger Target	CPA ≤ CPA LIMIT	
		0 ≤ TCPA ≤ TCPA LIMIT	
	Alarm Indication	Status	Symbol
Safe Target		△ (wht)	OFF
Danger Target		△ (red)	CPA/TCPA
Lost Target	Symbol on Display		
	Visible / Audible Alarm		
Data Indication	Target Data	Simultaneous and Continuous Display for 2 Targets	
	simple display	Ship's Name, Call Sign, MMSI, Course, Speed, CPA and TCPA	
	detail display	Ship's Name, Call Sign, MMSI, Course, Speed, CPA, TCPA, Bearing, Range, Ship's Heading Bearing, Rate of Turn, Latitude, Longitude, Destination and Navigation Status	
	Own Ship's Data	The ship's name, call sign, MMSI, course, speed, ship's heading bearing, rate of turn, latitude, longitude, destination and navigation status of own ship	
Trial Maneuver	Manual Setting		



Trial Course 0° to 360°  
Trial Speed 0 to 100 kn

Accuracy of Display	Complied with IMO Requirement
System Failure Alarm	Visible / Audible Alarm
Speed Input	Auto (LOG)

# Appendix B DRAWINGS

## DRAWINGS

B.1	Interconnection Diagram of Display Unit .....	B-1
B.1.1	NCD-9170 .....	B-2
B.1.2	NCD-9170T .....	B-3
B.1.3	NWZ-178-R .....	B-4
B.1.4	NWZ-178-RT .....	B-5
B.1.7	NCE-5322-R .....	B-6
B.1.8	NCE-5322-RT .....	B-7
B.2	Power System Diagram of Display Unit .....	B-8
B.3	Signal Flow Diagram of Display Unit .....	B-9
B.4	Primary Power System Diagram .....	B-10
B.5	Block Diagram of Scanner Unit .....	B-11
B.5.1	NKE-1532 .....	B-12
B.6	Interconnection Diagram of Scanner Unit .....	B-13
B.6.3	NKE-1532 (AC110V) .....	B-14
B.6.4	NKE-1532 (AC220V) .....	B-15
B.7	Terminal Board Connection Diagram .....	B-16
B.7.1	JMA-9172-SA .....	B-17

B.7.2	NCD-9170T .....	B-18
B.8	GYRO I/F .....	B-19
B.9	Inter Switch Unit .....	B-44
B.9.1	Terminal Board Connection Diagram .....	B-44
B.9.2	Interconnection Diagram .....	B-46

# **B.1** Interconnection Diagram of Display Unit





### B.1.3 NWZ-178-R

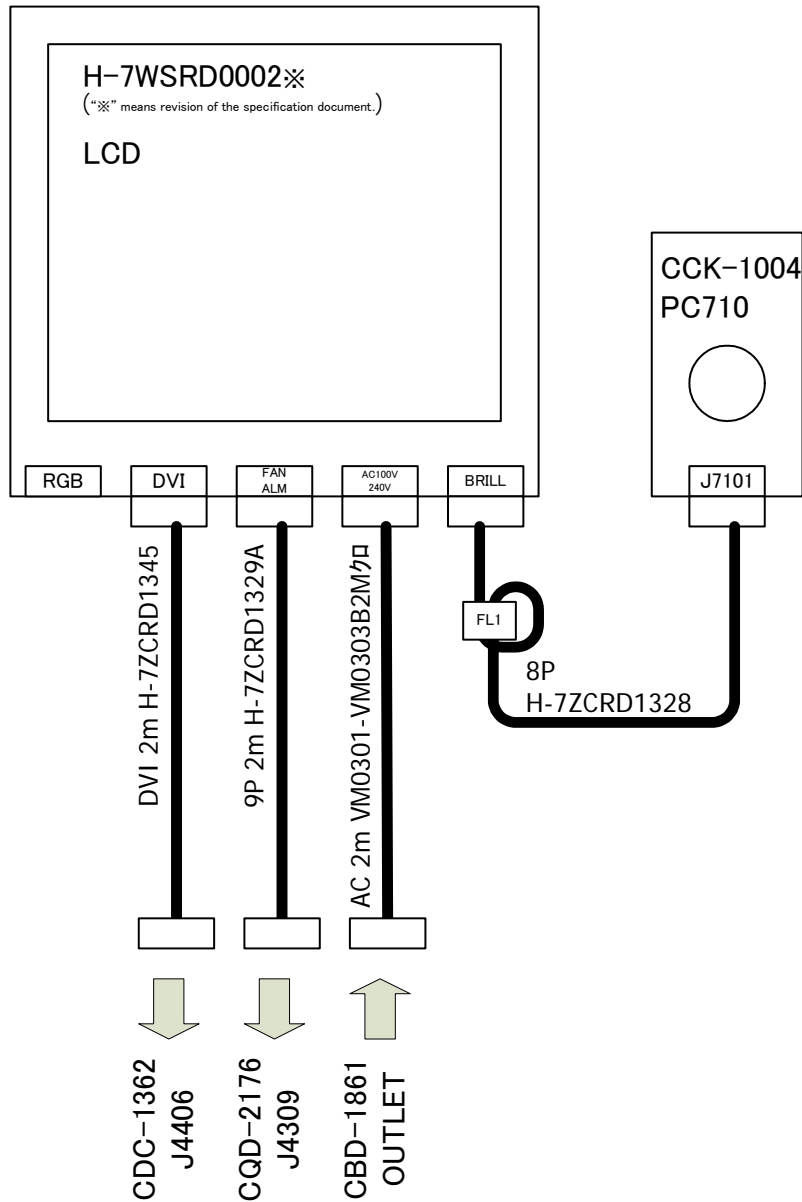

CML790-R (NWZ-178-R)

Monitor Unit Interconnection

Fig B-3: Interconnection Diagram of NWZ-178-R

### B.1.4 NWZ-178-RT

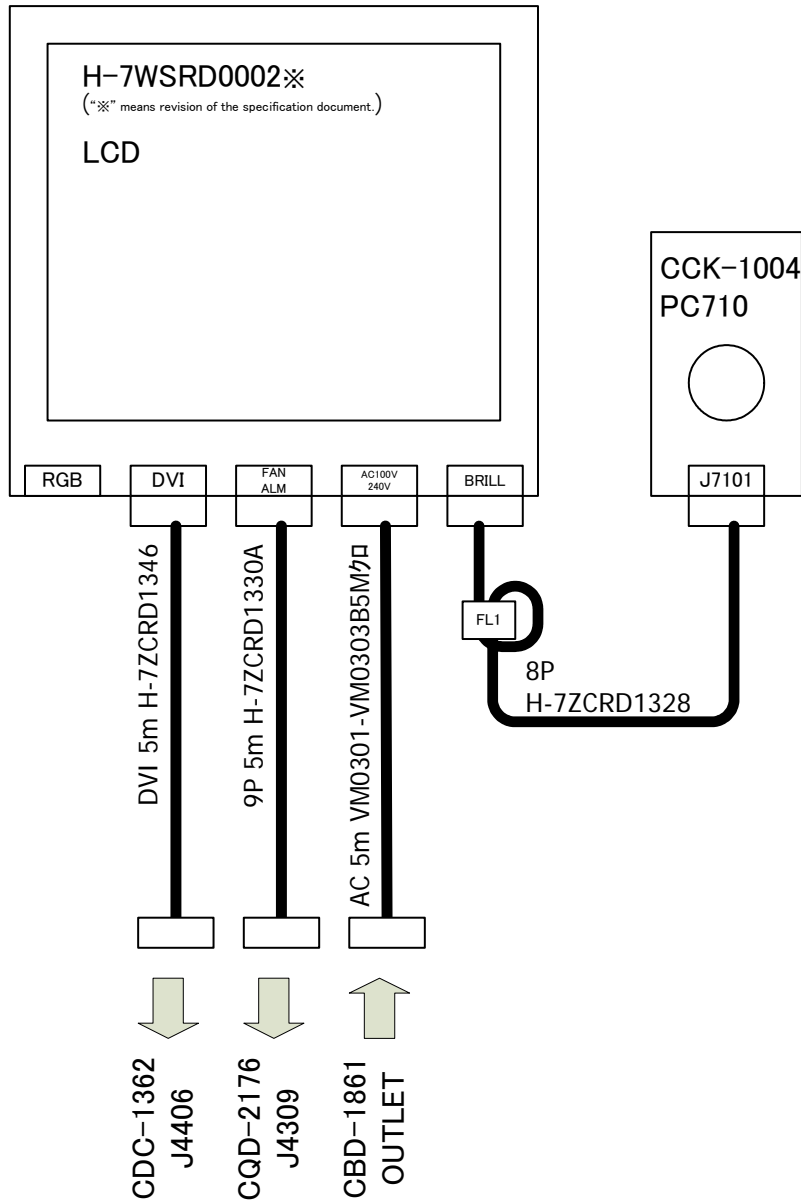

CML790-RT (NWZ-178-RT)

Monitor Unit Interconnection

Fig B-4: Interconnection Diagram of NWZ-178-RT



## B.1.5 NCE-5322-R

OPERATION UNIT  
NCE-5322-R

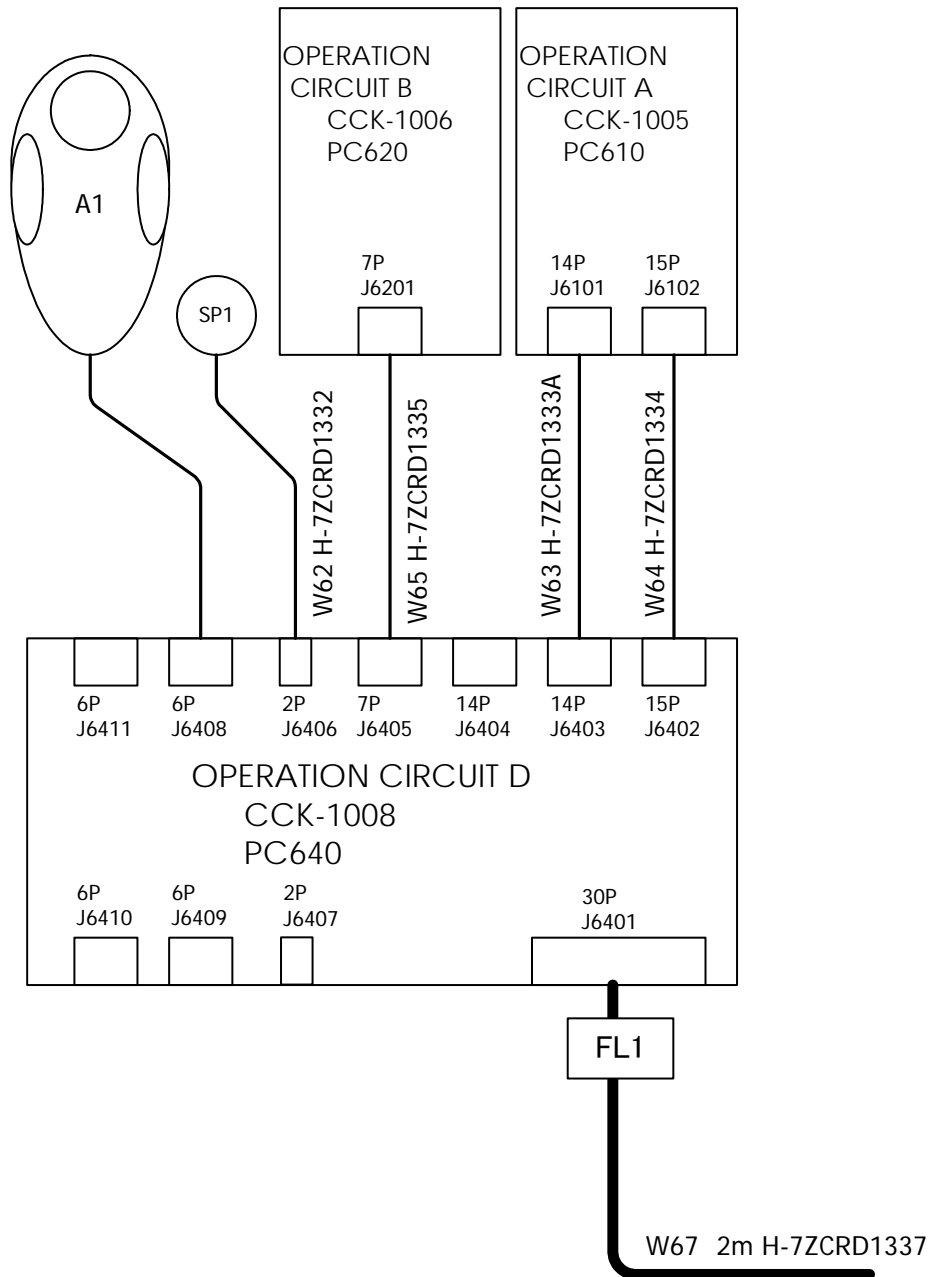

CMD-1031-R (NCE-5322-R)

Operation Unit Interconnection

Fig B-5: Interconnection Diagram of NCE-5322-R

## B.1.6 NCE-5322-RT

OPERATION UNIT  
NCE-5322-RT

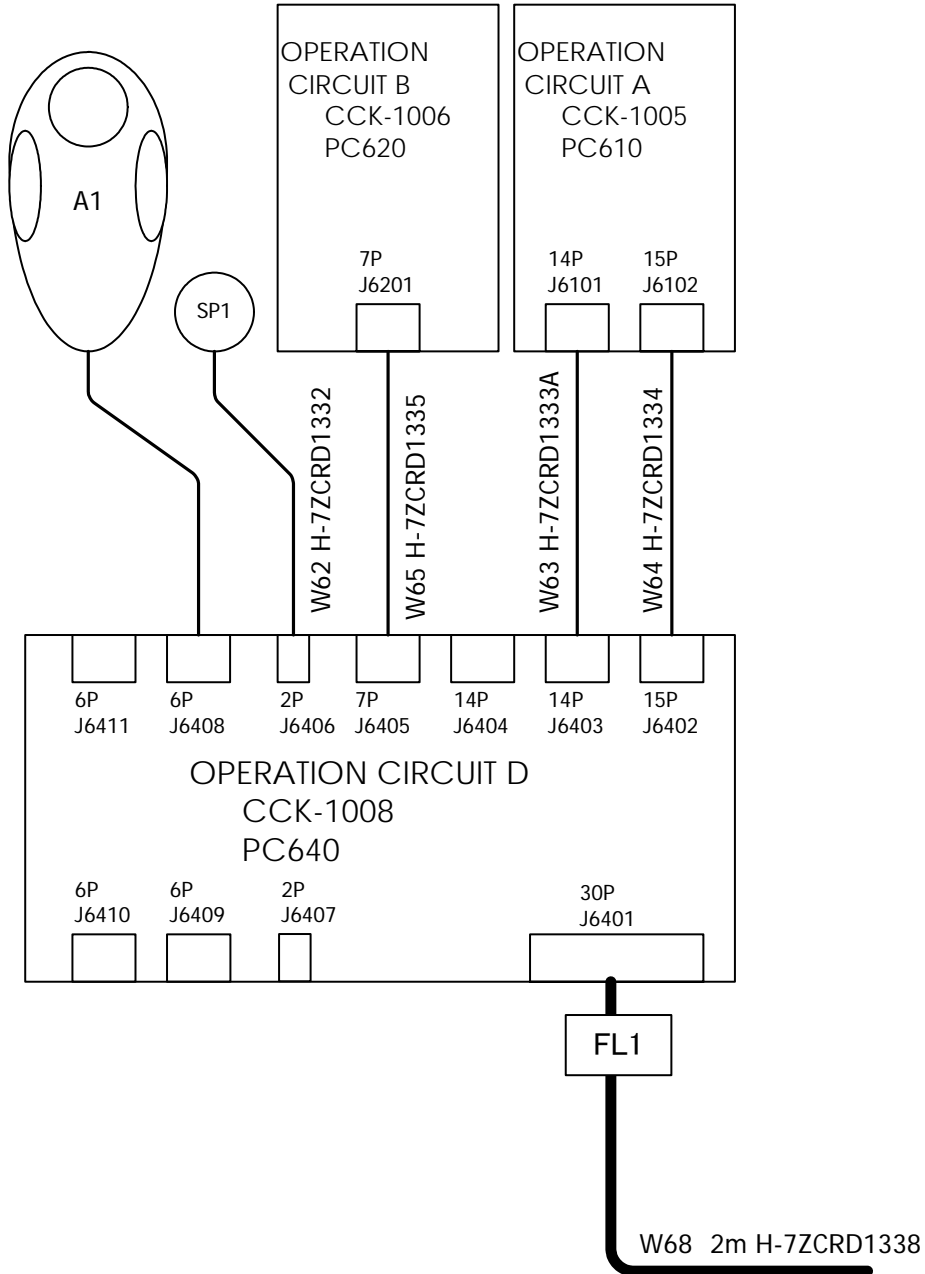

CMD-1031-RT (NCE-5322-RT)

Operation Unit Interconnection

Fig B-6: Interconnection Diagram of NCE-5322-RT

# B.2 Power System Diagram of Display Unit

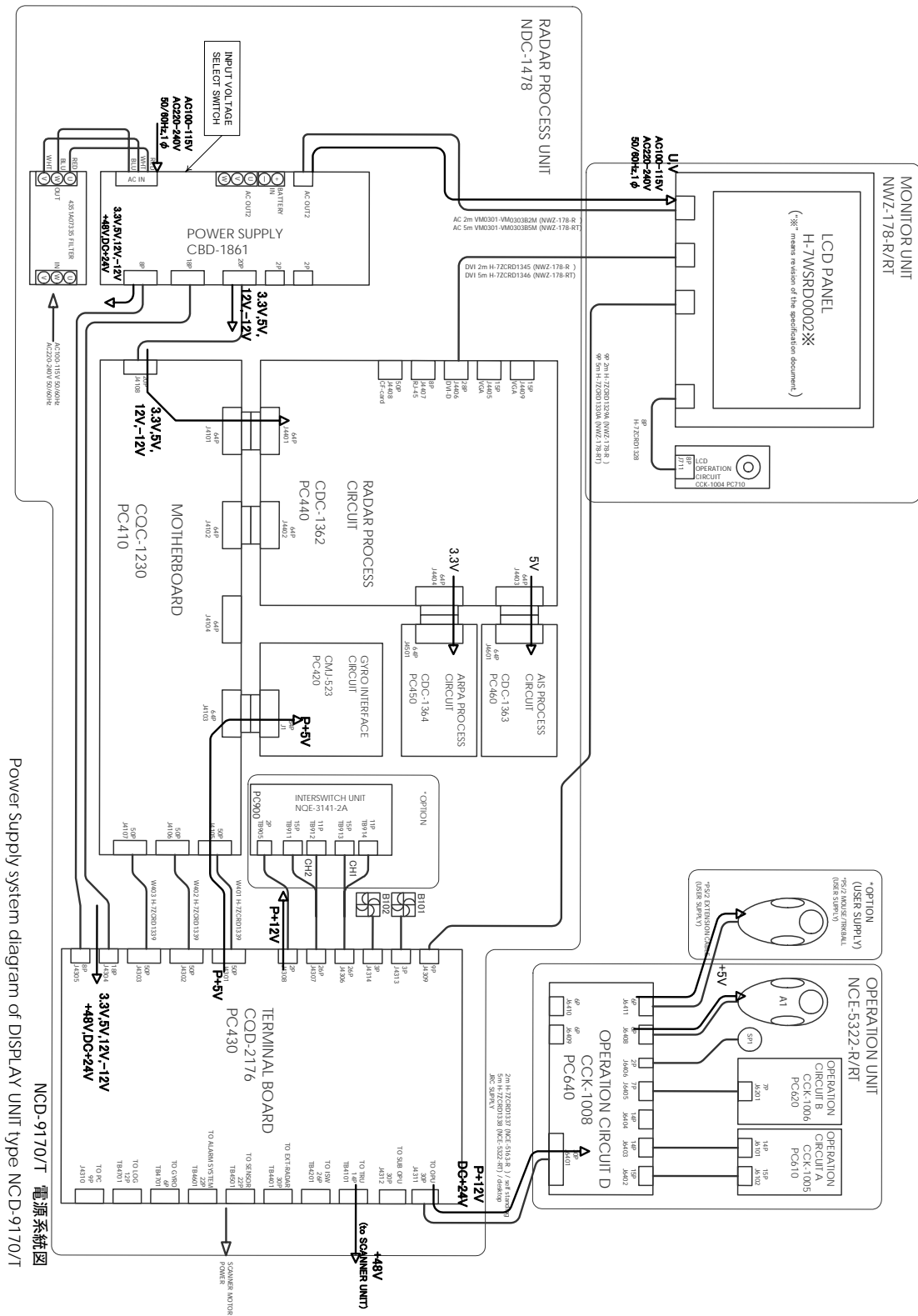
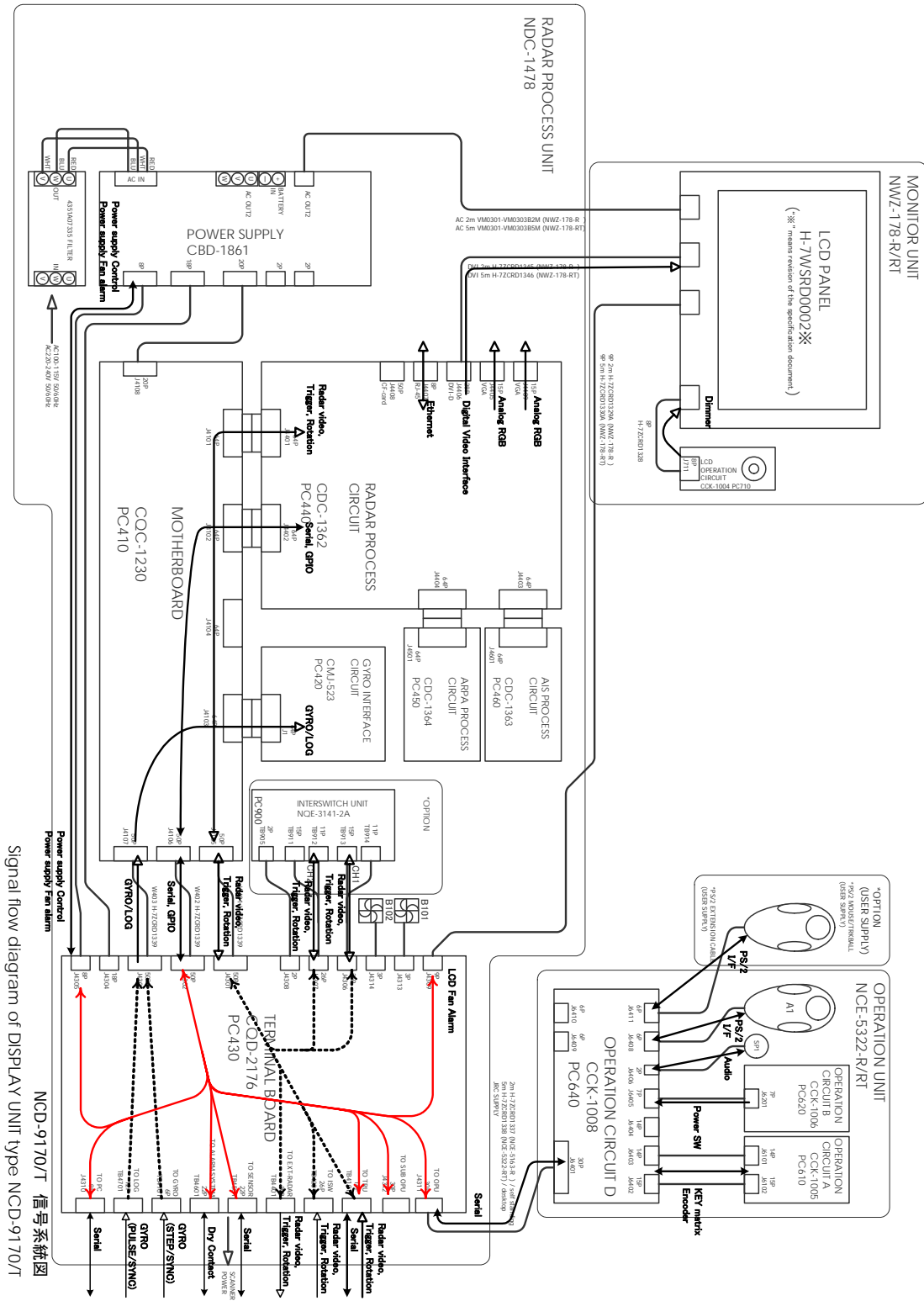

Fig B-7: Power System Diagram of NCD-9170/T

# B.3

## Signal Flow Diagram of Display Unit



Signal flow diagram of DISPLAY UNIT type NCD-9170/T  
NCD-9170/T 信号系統図

Fig B-8: Signal Flow Diagram of NCD-9170/T

# B.4

## Primary Power System Diagram

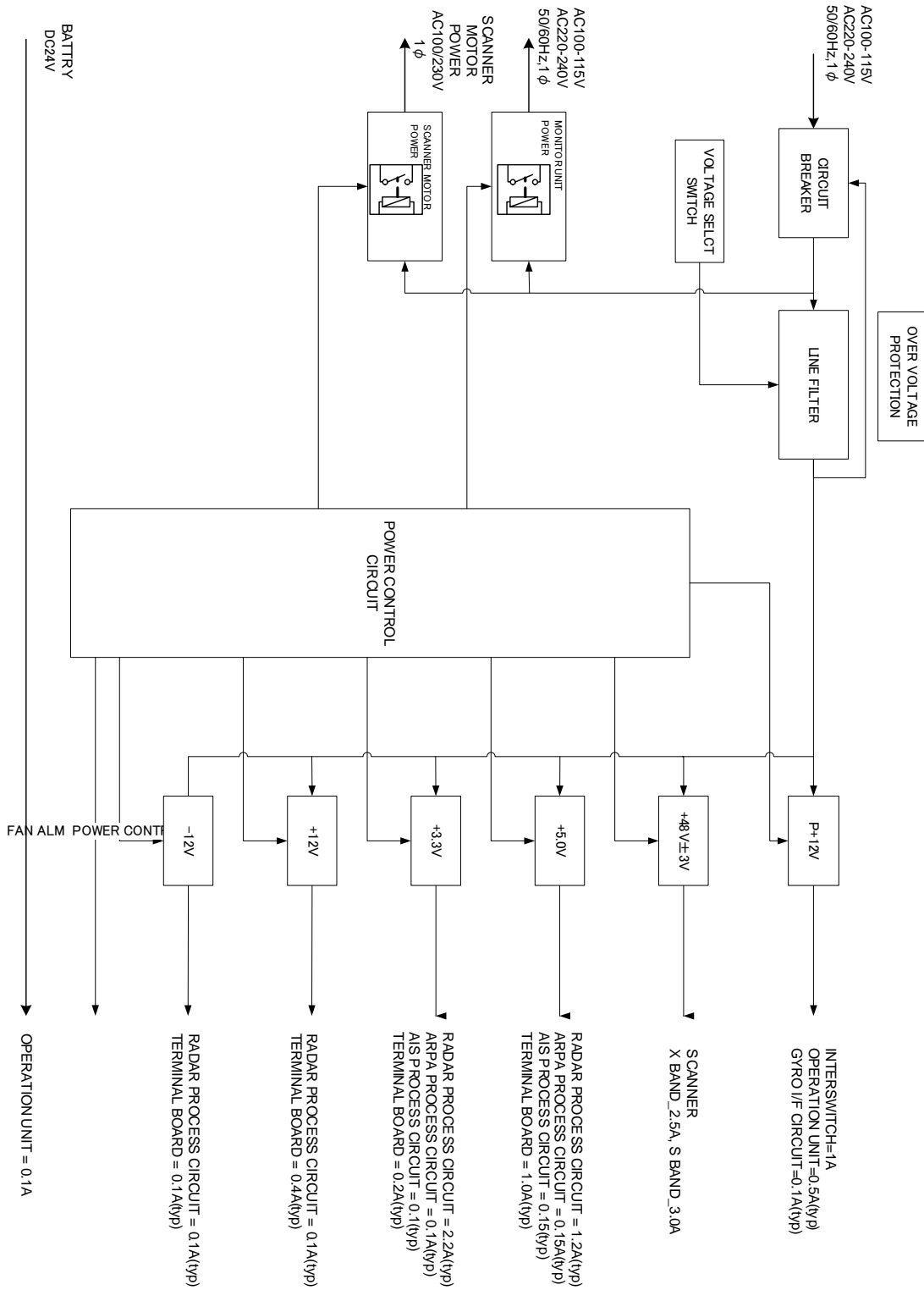

Fig B-9: Primary Power System Diagram

# **B.5**

## Block Diagram of Scanner Unit

### B.5.1 NKE-1532

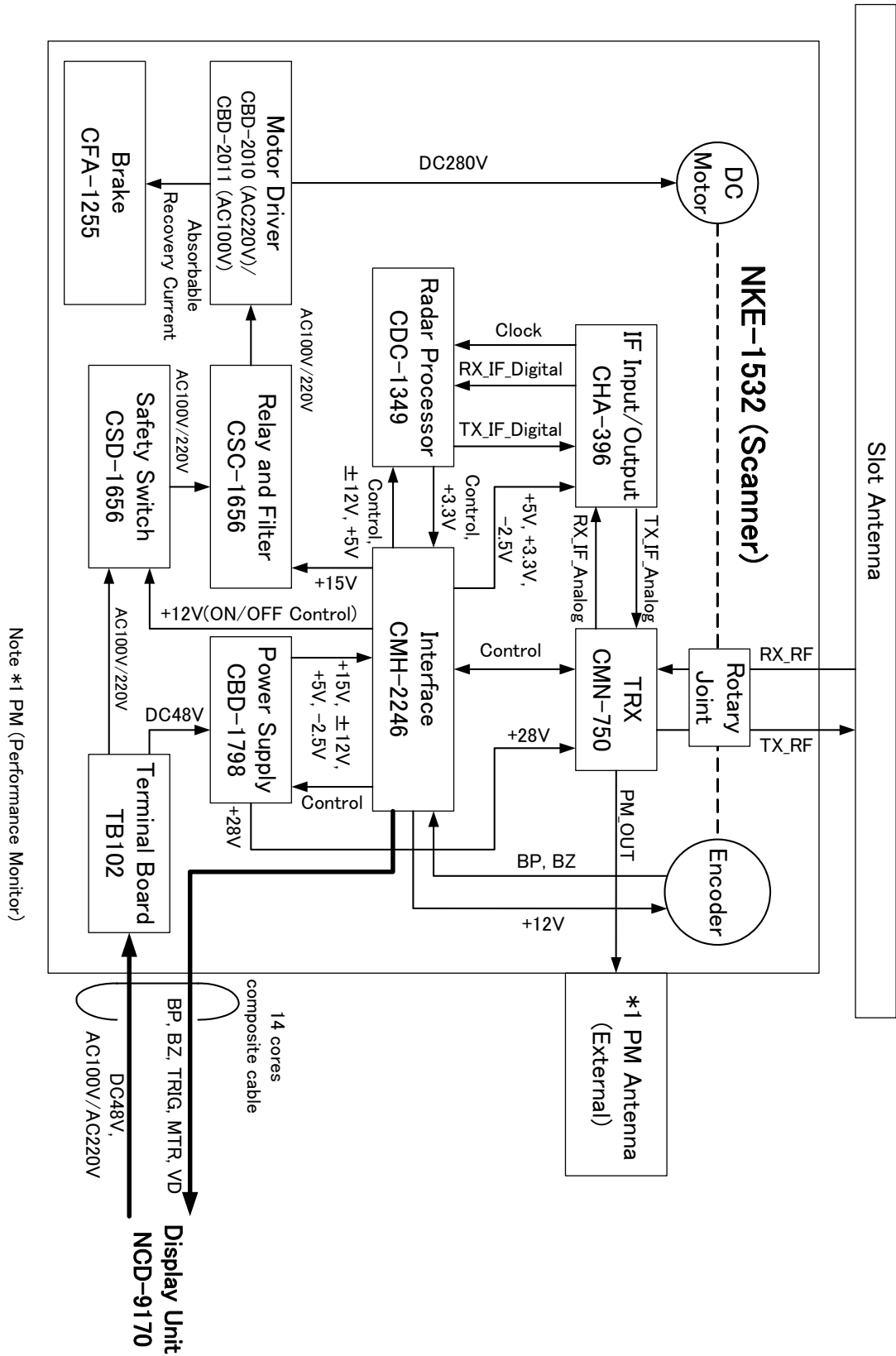

Fig B-10: Block Diagram of NKE-1532

# **B.6**

## Interconnection Diagram of Scanner Unit





## B.6.2 NKE-1532 (AC220V)

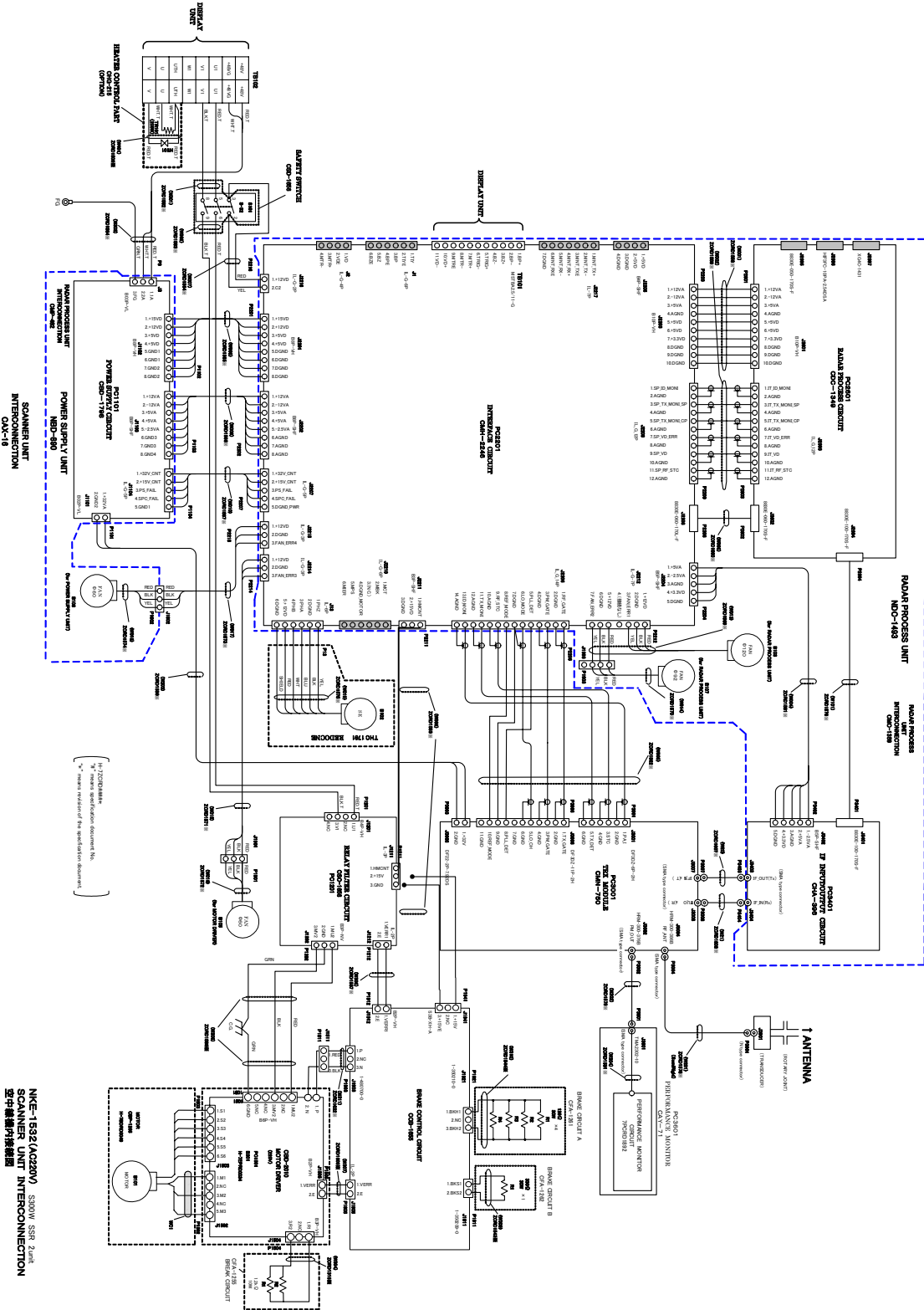

Fig B-12: Interconnection Diagram of NKE-1532 (AC220V)



# **B.7** Terminal Board Connection Diagram



## B.7.2 NCD-9170T

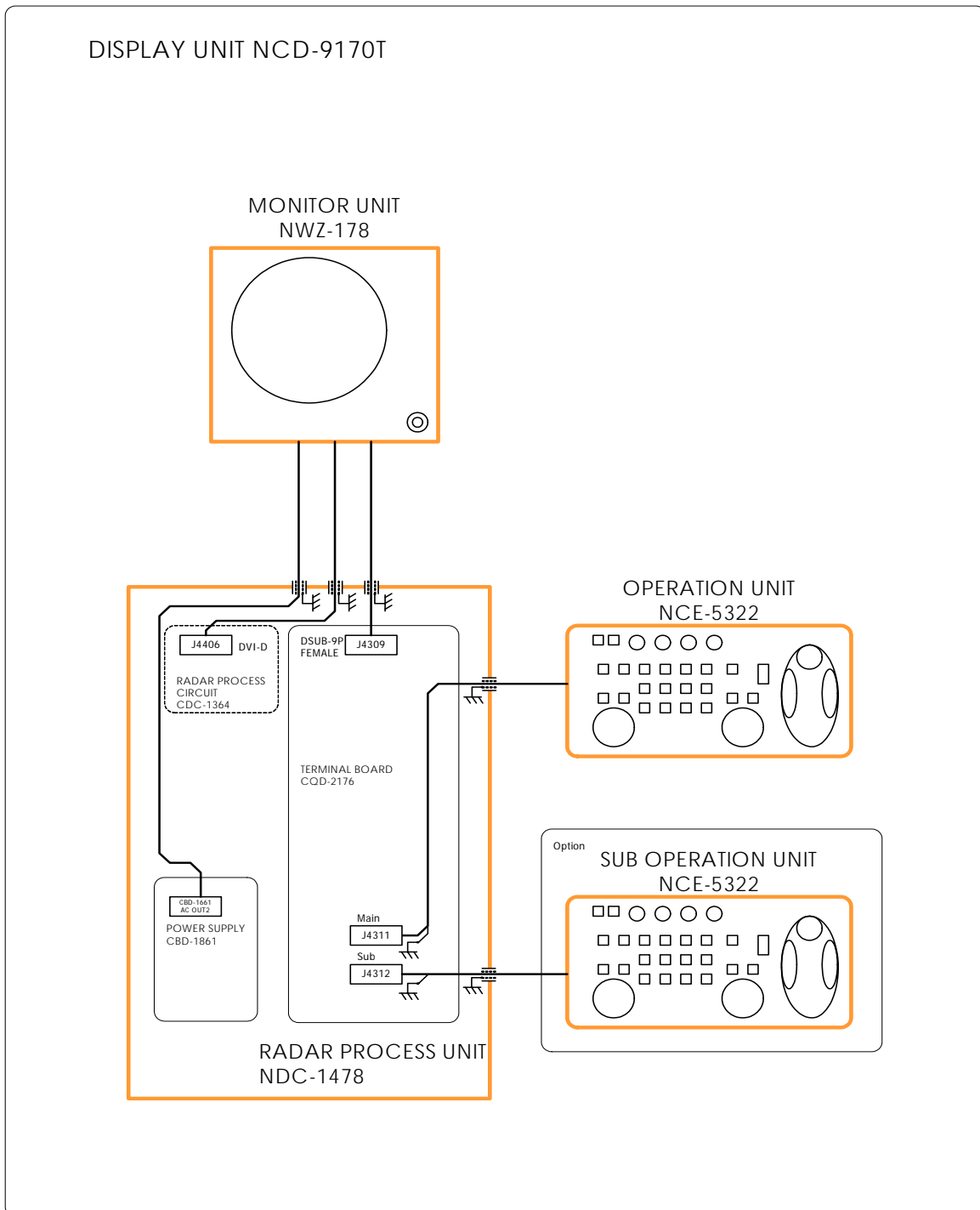

JMA-9172-SA RADAR  
NCD-9170T 卓上型レーダー指示機 ユニット間接続図  
INTERCONNECTION DIAGRAM OF DISPLAY UNIT TYPE NCD-9170T(desktop)

Fig B-14: Inter-Unit Connection Diagram of NCD-9170T

# B.8 GYRO I/F

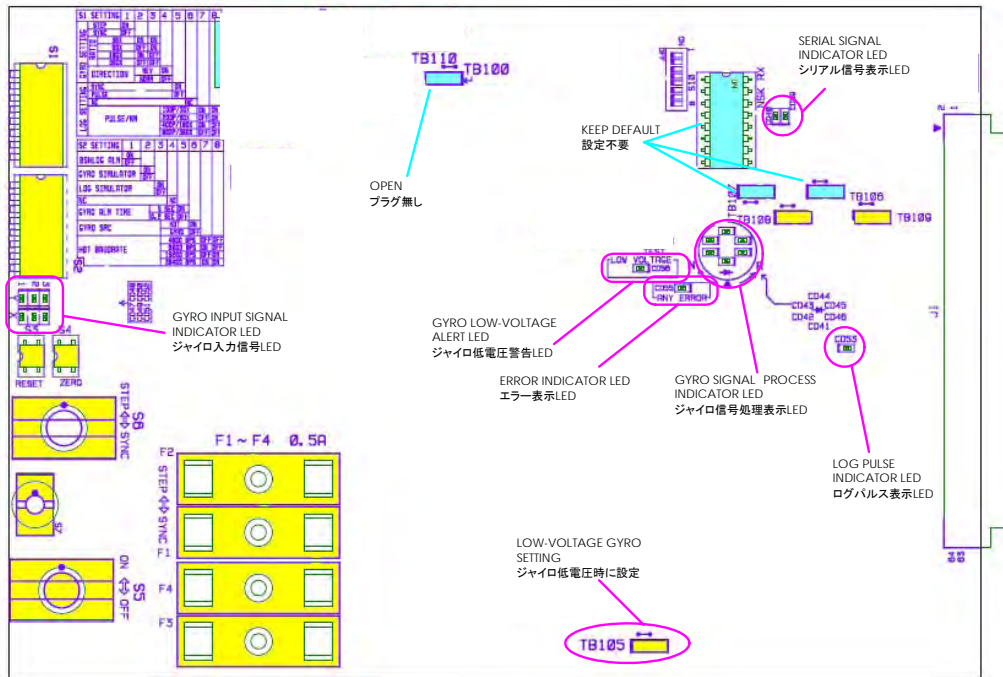

Fig B-15: Parts Location of CMJ-523

TableB-1 : Setting Table of CMJ-523 S1/S2

S1 SETTING		1	2	3	4	5	6	7	8	
ジャイロ信号号 GYRO SETTING	STEP	ON								
	SYNC	OFF								
	RATIO	36X	ON	ON						
		90X	OFF	ON						
		180X	ON	OFF						
360X		OFF	OFF							
回転方向 DIRECTION	逆/REV			ON						
シンクロ/SYNC	正/NOR		OFF		ON					
ログ信号号 LOG SETTING	パルス/PULSE				OFF					
	未接続/NC				OFF					
	パルス PULSE/NM	100P/30X				ON	ON			
		200P/90X				OFF	ON			
		400P/180X				ON	OFF			
800P/360X				OFF	OFF					

S2 SETTING		1	2	3	4	5	6	7	8
BSHLOG ALM	ON								
	OFF								
GYRO SIMULATOR	ON								
	OFF								
LOG SIMULATOR			ON						
			OFF						
N.C. (No Connection)				OFF					
GYRO ALM TIME	5 SEC				ON				
	0.2 SEC				OFF				
GYRO SRC (Heading Sensor Source)	HDT ( NMEA (HDT/THS) )				ON				
	GYRO				OFF				
NMEA BAUDRATE	4800 BPS					OFF	OFF		
	9600 BPS						ON	ON	
	19200 BPS						OFF	ON	
	38400 BPS						ON	ON	



# Appendix C

## Menu Index

### Menu Index

C.1	Main .....	C-1
C.2	PI .....	C-4
C.3	TT .....	C-5
C.4	AIS .....	C-6
C.5	AZ .....	C-7
C.6	Track .....	C-8
C.7	Route .....	C-9
C.8	U.Map .....	C-10
C.9	Serviceman Menu .....	C-11





# C.1 Main

付図 レーダーメニュー階層  
Fig. Over View of RADAR Menu

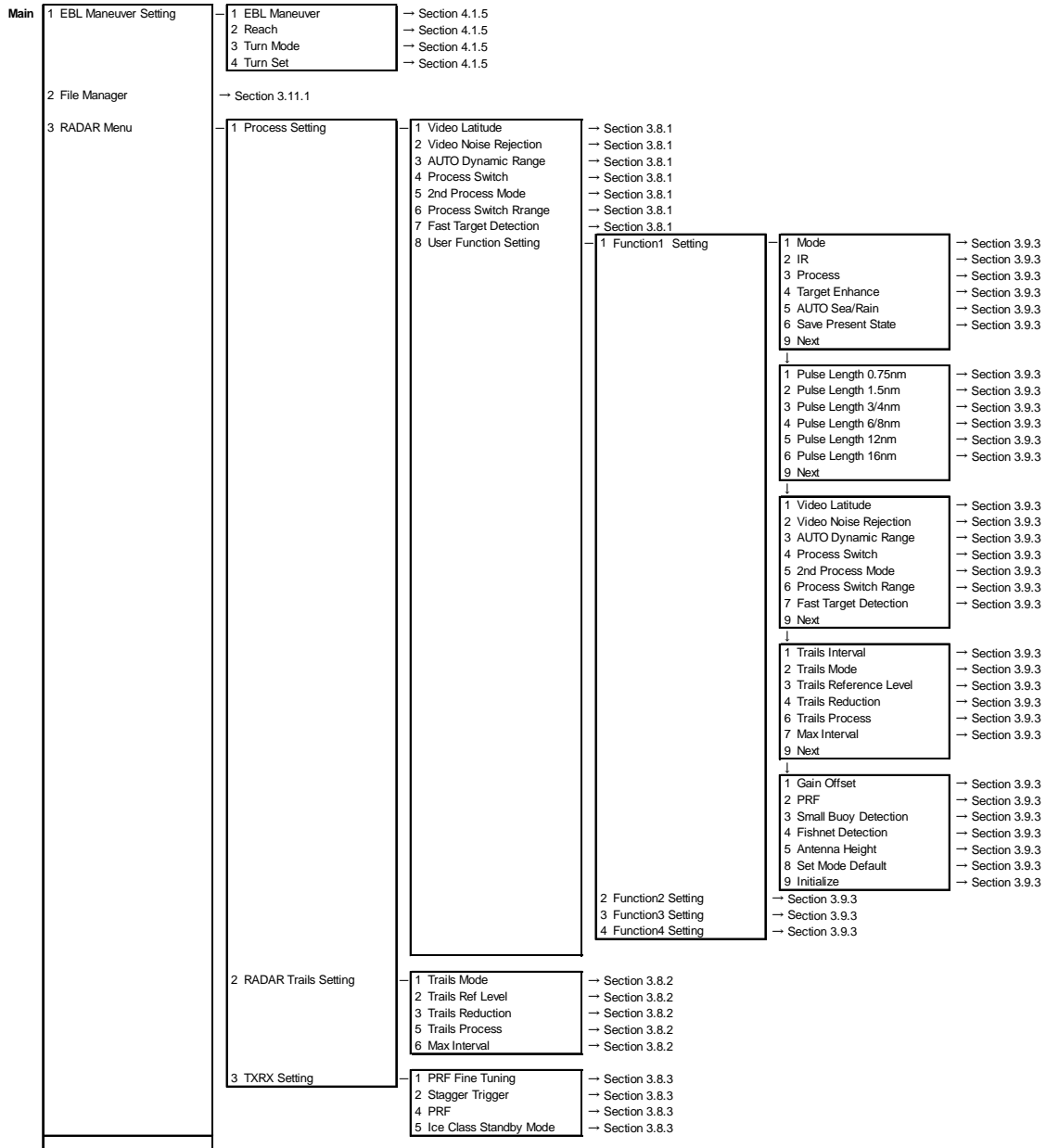

Main	4 Multi Window Setting	1 DIR/DIST EXP Display	→ Section 3.8.8		
		2 Numeric NAV INFO	→ Section 3.8.8		
		3 Depth Graph Setting	1 Depth Graph Display	→ Section 3.8.8	
			2 Depth Range	→ Section 3.8.8	
			3 Time Range	→ Section 3.8.8	
			4 Depth Unit	→ Section 3.8.8	
			4 Wind Graph Setting	1 Wind Graph Display	→ Section 3.8.8
				2 Wind Speed Unit	→ Section 3.8.8
			5 TEMP Graph Setting	1 TEMP Graph Display	→ Section 3.8.8
				2 TEMP Graph Color	→ Section 3.8.8
		3 TEMP Range	1 Temperature setting (MIN)	→ Section 3.8.8	
			2 Temperature setting	→ Section 3.8.8	
			3 Temperature setting	→ Section 3.8.8	
			4 Temperature setting	→ Section 3.8.8	
			5 Temperature setting	→ Section 3.8.8	
			6 Temperature setting (MAX)	→ Section 3.8.8	
		4 Time Range	→ Section 3.8.8		
	6 Course Bar Setting	1 Course Bar Display	→ Section 3.8.8		
		2 Autopilot Course	→ Section 3.8.8		
		3 ROT Scale	→ Section 3.8.8		
5 Map Setting	3 JRC/ERC Setting	1 Day/Night			
		2 Color of Land			
		3 Bright of Land			
		4 Color of Sea			
		5 Bright of Sea			
	6 Color of Name				
	7 Bright of Name				
	8 Bright of Track/Mark/Line				
	9 Next				
	↓				
	1 LAT/LON Line				
	2 Color of L/L Line				
	3 Bright of L/L Line				
	5 Map Display Setting	3 LAT/LON Correction			
	7 Map Draw AZI Mode				
6 NAV Equipment Setting	1 GYRO Setting	→ Section 3.4.14 → Section 7.1.7			
	2 MAG Compass Setting	1 Heading Correction	→ Section 3.4.16		
		2 Correct Value	→ Section 3.4.16		
	3 Set/Drift Setting	1 Correction	→ Section 3.4.16		
		2 Set	→ Section 3.4.16		
		3 Drift	→ Section 3.4.16		
7 Sub Menu	1 Display Color Setting	1 Day/Night	→ Section 3.8.5		
		2 Outer PPI	→ Section 3.8.5		
		3 Inner PPI	→ Section 3.8.5		
		4 Character	→ Section 3.8.5		
		5 RADAR Video	→ Section 3.8.5		
		6 RADAR Trails(Time)	→ Section 3.8.5		
		8 Target Symbol	→ Section 3.8.5		
		9 Next			
		↓			
		1 Cursor	→ Section 3.8.5		
2 Range Rings	→ Section 3.8.5				
3 EBL/VRM/PI	→ Section 3.8.5				
4 Own Symbol/HL/Vector	→ Section 3.8.5				
2 Brilliance Setting	1 RADAR Video	→ Section 3.8.5			
	2 RADAR Trails	→ Section 3.8.5			
	3 Target Symbol	→ Section 3.8.5			
	4 Range Rings	→ Section 3.8.5			
	5 EBL/VRM/PI	→ Section 3.8.5			
	6 Character	→ Section 3.8.5			
	7 Own Symbol/HL/Vector	→ Section 3.8.5			
	8 Keyboard	→ Section 3.8.5			
3 User Setting	1 Load User Setting	→ Section 3.10.2			
	2 Save User Setting	→ Section 3.10.1			
	3 Delete User Setting	→ Section 3.10.3			
4 Option Key Setting	1 Option1	→ Section 3.8.7			
	2 Option2	→ Section 3.8.7			
Main 7 Sub Menu	5 Buzzer Volume	1 Key ACK	→ Section 3.8.6		
		2 OPE Miss	→ Section 3.8.6		
		3 CPA/TCPA Alarm	→ Section 3.8.6		
		4 New Target Alarm	→ Section 3.8.6		
		5 Lost Alarm	→ Section 3.8.6		
		6 Navigation Alarm	→ Section 3.8.6		
		7 System Alarm	→ Section 3.8.6		
		8 Inter Switch	→ Section 3.8.6		

8 Plot Setting	6 Date/Time Setting	<ul style="list-style-type: none"> <li>1 UTC/LMT → Section 7.2.6</li> <li>2 LMT Date → Section 7.2.6</li> <li>3 LMT Time → Section 7.2.6</li> <li>4 Time Zone → Section 7.2.6</li> <li>5 Display Style → Section 7.2.6</li> <li>6 Synchronize with GPS → Section 7.2.6</li> </ul>	
	7 Screen Capture Setting	<ul style="list-style-type: none"> <li>1 Select Item                             <ul style="list-style-type: none"> <li>1 Graphic</li> <li>2 RADAR Video</li> <li>3 RADAR Trails</li> <li>4 Chart</li> </ul> </li> <li>2 Select Card Slot</li> <li>3 File Erase</li> <li>4 AUTO Capture Interval</li> <li>5 AUTO File Erase</li> </ul>	
	9 EBL/Cursor Setting	<ul style="list-style-type: none"> <li>1 EBL1 Bearing Fix → Section 4.1.3</li> <li>2 EBL2 Bearing Fix → Section 4.1.3</li> <li>3 Cursor Setting                             <ul style="list-style-type: none"> <li>1 EBL/VRM Control Cursor → Section 3.8.4</li> <li>2 Cursor Length → Section 3.8.4</li> <li>4 Cursor Pattern → Section 3.8.4</li> </ul> </li> </ul>	
	6 AUTO Backup	→ Section 3.8.9	
	9 Test Menu	1 Self Test	<ul style="list-style-type: none"> <li>1 Memory Test                             <ul style="list-style-type: none"> <li>1 SDRAM → Section 8.3.1</li> <li>2 SRAM → Section 8.3.1</li> <li>3 FLASH ROM → Section 8.3.1</li> <li>4 GRAPHIC → Section 8.3.1</li> </ul> </li> <li>2 Sensor Test → Section 8.3.1</li> <li>3 Line Test → Section 8.3.1</li> <li>4 Supply Voltage → Section 8.3.1</li> </ul>
		2 Monitor Test	<ul style="list-style-type: none"> <li>1 Pattern 1 → Section 8.3.1</li> <li>2 Pattern 2 → Section 8.3.1</li> <li>3 Pattern 3 → Section 8.3.1</li> <li>4 Pattern 4 → Section 8.3.1</li> <li>5 Pattern 5 → Section 8.3.1</li> <li>6 Pattern 6 → Section 8.3.1</li> <li>7 Pattern 7 → Section 8.3.1</li> <li>8 Pattern 8 → Section 8.3.1</li> </ul>
		3 Keyboard Test	<ul style="list-style-type: none"> <li>1 Key Test → Section 8.3.1</li> <li>2 Buzzer Test → Section 8.3.1</li> <li>3 Light Test → Section 8.3.1</li> </ul>
		4 MON Display	→ Section 8.3.1
		5 System Alarm Log	→ Section 8.3.1
		6 System Information	→ Section 8.3.1
7 SSR Information		→ Section 8.3.1	
0 EXIT			



# C.3

# TT

TT	1 Association Setting	1 Association	→ Section 5.4
		2 Priority	→ Section 5.4
		3 Bearing	→ Section 5.4
		4 Range	→ Section 5.4
		5 Course	→ Section 5.4
		6 Speed	→ Section 5.4
	2 Target Track Setting	1 Target Track Function	→ Section 5.6.2
		2 Target Track Color	1 All → Section 5.6.2 2 Target Track No. 1 → Section 5.6.2 3 Target Track No. 2 → Section 5.6.2 4 Target Track No. 3 → Section 5.6.2 5 Target Track No. 4 → Section 5.6.2 6 Target Track No. 5 → Section 5.6.2 7 Target Track No. 6 → Section 5.6.2 8 Target Track No. 7 → Section 5.6.2 9 Next
			1 Target Track No. 8 → Section 5.6.2 2 Target Track No. 9 → Section 5.6.2 3 Target Track No. 10 → Section 5.6.2 4 Other → Section 5.6.2
		3 Target Track Display	1 All → Section 5.6.2 2 Target Track No. 1 → Section 5.6.2 3 Target Track No. 2 → Section 5.6.2 4 Target Track No. 3 → Section 5.6.2 5 Target Track No. 4 → Section 5.6.2 6 Target Track No. 5 → Section 5.6.2 7 Target Track No. 6 → Section 5.6.2 8 Target Track No. 7 → Section 5.6.2 9 Next 1 Target Track No. 8 → Section 5.6.2 2 Target Track No. 9 → Section 5.6.2 3 Target Track No. 10 → Section 5.6.2 4 Other → Section 5.6.2
	4 Track Memory Interval	→ Section 5.6.2	
	5 Clear Track Color	→ Section 5.6.2	
	6 Clear Track Number	→ Section 5.6.2	
	7 File Operations	1 Select Card Slot → Section 5.6.2 2 Load Mode → Section 5.6.2 3 Load → Section 5.6.2 4 Save → Section 5.6.2 5 Erase → Section 5.6.2 6 Card T.TRK Display → Section 5.6.2	
3 Trial Maneuver	1 Trial Function	→ Section 5.7	
	2 Course(EBL)	→ Section 5.7	
	3 Speed(VRM)	→ Section 5.7	
	4 Vector Time	→ Section 5.7	
	5 Time to Maneuver	→ Section 5.7	
	6 Own Ship's Dynamic Trail	1 Reach → Section 5.7 3 Turn Radius → Section 5.7 4 Acceleration → Section 5.7 5 Deceleration → Section 5.7	
4 Target Number Display		→ Section 5.2.4	
9 TT Test Menu	1 Test Video	→ Section 5.2.7	
	2 TT Simulator	→ Section 5.2.7	
	3 Status	→ Section 5.2.7	
	4 Gate Display	→ Section 5.2.7	

# C.4

# AIS

AIS	1 Association Setting	1 Association → Section 5.4
		2 Priority → Section 5.4
		3 Bearing → Section 5.4
		4 Range → Section 5.4
		5 Course → Section 5.4
		6 Speed → Section 5.4
		7 Applicable AIS Target → Section 5.4
	2 Target Track Setting	1 Target Track Function → Section 5.6.2
		2 Target Track Color
		1 All → Section 5.6.2
		2 Target Track No.1 → Section 5.6.2
		3 Target Track No.2 → Section 5.6.2
		4 Target Track No.3 → Section 5.6.2
		5 Target Track No.4 → Section 5.6.2
		6 Target Track No.5 → Section 5.6.2
	7 Target Track No.6 → Section 5.6.2	
	8 Target Track No.7 → Section 5.6.2	
	9 Next	
	1 Target Track No.8 → Section 5.6.2	
	2 Target Track No.9 → Section 5.6.2	
	3 Target Track No.10 → Section 5.6.2	
	4 Other → Section 5.6.2	
	3 Target Track Display	
	1 All → Section 5.6.2	
	2 Target Track No.1 → Section 5.6.2	
	3 Target Track No.2 → Section 5.6.2	
	4 Target Track No.3 → Section 5.6.2	
	5 Target Track No.4 → Section 5.6.2	
	6 Target Track No.5 → Section 5.6.2	
	7 Target Track No.6 → Section 5.6.2	
	8 Target Track No.7 → Section 5.6.2	
	9 Next	
	1 Target Track No.8 → Section 5.6.2	
	2 Target Track No.9 → Section 5.6.2	
	3 Target Track No.10 → Section 5.6.2	
	4 Other → Section 5.6.2	
	4 Track Memory Interval → Section 5.6.2	
	5 Clear Track Color → Section 5.6.2	
	6 Clear Track Number → Section 5.6.2	
	7 File Operations	
	1 Select Card Slot → Section 5.6.2	
	2 Load Mode → Section 5.6.2	
	3 Load → Section 5.6.2	
	4 Save → Section 5.6.2	
	5 Erase → Section 5.6.2	
	6 Card T.TRK Display → Section 5.6.2	
3 Trial Maneuver	1 Trial Function → Section 5.7	
	2 Course(EBL) → Section 5.7	
	3 Speed(VRM) → Section 5.7	
	4 Vector Time → Section 5.7	
	5 Time to Maneuver → Section 5.7	
	6 Own Ship's Dynamic Trail	
	1 Reach → Section 5.7	
	2 Turn Radius → Section 5.7	
	3 Acceleration → Section 5.7	
	4 Deceleration → Section 5.7	
4 AIS Filter Setting	1 Filter Type → Section 5.3.7	
	2 Make AIS Filter → Section 5.3.7	
	3 Filter Display → Section 5.3.7	
	4 ENT	
	6 Filter Mode → Section 5.3.7	
5 Target Number Display	→ Section 5.3.6	
6 AIS Alarm Setting	1 Lost Alarm → Section 5.3.9	
	2 CPA/TCPA Alarm → Section 5.3.9	
7 Message	1 Addressed Message → Section 5.3.5	
	2 Broadcast Message → Section 5.3.5	
8 Display Lost TGT Data	→ Section 5.3.5	
9 Own Ship's AIS Data	→ Section 5.3.5	

**C.5** AZ

AZ	1 AZ 1	→ Section 5.2.1
	2 AZ 2	→ Section 5.2.1
	3 Make AZ 1	→ Section 5.2.1
	4 Make AZ 2	→ Section 5.2.1
	5 ENT	





# C.6

## Track

Track	1 DISP Own Track Color	<ul style="list-style-type: none"> <li>1 All → Section 3.5.2</li> <li>2 White → Section 3.5.2</li> <li>3 Cyan → Section 3.5.2</li> <li>4 Blue → Section 3.5.2</li> <li>5 Green → Section 3.5.2</li> <li>6 Yellow → Section 3.5.2</li> <li>7 Pink → Section 3.5.2</li> <li>8 Red → Section 3.5.2</li> </ul>
	2 Clear Own Track Color	→ Section 3.5.5
	3 Track Type	→ Section 3.5.6
	4 Num/Vector Display	→ Section 3.5.6
	5 File Operations	<ul style="list-style-type: none"> <li>1 Select Card Slot</li> <li>2 Load Mode</li> <li>3 Load</li> <li>4 Save</li> <li>5 Erase</li> <li>6 Card Own Track Display</li> </ul>
	6 Water Depth Setting	<ul style="list-style-type: none"> <li>1 Depth setting (MIN) → Section 3.5.7</li> <li>2 Depth setting → Section 3.5.7</li> <li>3 Depth setting → Section 3.5.7</li> <li>4 Depth setting → Section 3.5.7</li> <li>5 Depth setting → Section 3.5.7</li> <li>6 Depth setting (MAX) → Section 3.5.7</li> </ul>
	7 Water TEMP Setting	<ul style="list-style-type: none"> <li>1 Temperature setting (MIN) → Section 3.5.8</li> <li>2 Temperature setting → Section 3.5.8</li> <li>3 Temperature setting → Section 3.5.8</li> <li>4 Temperature setting → Section 3.5.8</li> <li>5 Temperature setting → Section 3.5.8</li> <li>6 Temperature setting (MAX) → Section 3.5.8</li> </ul>
	8 Current Setting	<ul style="list-style-type: none"> <li>1 Current Size → Section 3.5.9</li> <li>2 Layer A → Section 3.5.9</li> <li>3 Layer B → Section 3.5.9</li> <li>4 Layer C → Section 3.5.9</li> </ul>

# C.7 Route

Route	1 Select Route	→ Section 3.7.1	
	2 WPT/Route Settig	1 Waypoint Alarm	→ Section 3.7.4
		2 Route Alarm	→ Section 3.7.4
		5 Waypoint Entry	
		6 Waypoint Input	→ Section 3.7.3
		7 Save Temporary Route	
		8 Route Alarm Color	→ Section 3.7.6
		9 Next	
		↓	
		1 SEL_NUM/Comment Size	→ Section 3.7.6
2 Waypoint Vector	→ Section 3.7.6		
3 Status of Origin/DEST	→ Section 3.7.6		
4 WPT Number Display	→ Section 3.7.6		
3 WPT/Route Operations	1 Route Sequence	→ Section 3.7.5	
	2 Waypoint Switch Mode	→ Section 3.7.6	
	3 Waypoint Skip	→ Section 3.7.5	
	4 Waypoint Back Skip	→ Section 3.7.5	
	5 Set/Cancel Waypoint		
	6 Clear WPT/Route Data	→ Section 3.7.7	
4 File Operations	1 Select Card Slot	→ Section 3.7.8	
	2 Load	→ Section 3.7.8	
	3 Save	→ Section 3.7.8	
	4 Erase	→ Section 3.7.8	

# C.8

## U.Map

U.Map	1 Own Ship Position	→ Section 3.6.3		
	2 Edit User Map		1 Make with Cursor	1 Type → Section 3.6.1 2 Color → Section 3.6.1
			2 Make with L/L	1 Type → Section 3.6.1 2 Color → Section 3.6.1 3 L/L → Section 3.6.1 4 Comment → Section 3.6.1 5 Enter → Section 3.6.1 9 New Line Input → Section 3.6.1
			3 Move	→ Section 3.6.3
			4 Delete	→ Section 3.6.3
			5 Insert/Move Vertex	→ Section 3.6.3
			6 Delete Vertex	→ Section 3.6.3
			7 Delete by Type by Color	→ Section 3.6.3
	3 Shift	→ Section 3.6.4		
	4 Shift Clear	→ Section 3.6.4		
5 Mark Display Setting		1 Display Mark Type	1 All → Section 3.6.2 2 O → Section 3.6.2 3 Δ → Section 3.6.2 4 ▽ → Section 3.6.2 5 □ → Section 3.6.2 6 ◇ → Section 3.6.2 7 Wreck (mark) → Section 3.6.2 8 Δ Δ → Section 3.6.2 9 Next → Section 3.6.2	
			1 ▽ ▽ → Section 3.6.2 2 Δ ▽ → Section 3.6.2 3 ▽ Δ → Section 3.6.2 4 + → Section 3.6.2 5 x → Section 3.6.2 6 Y → Section 3.6.2 7 Hand drum (mark) → Section 3.6.2 8 Light house (mark) → Section 3.6.2 9 Next → Section 3.6.2	
			1 Trapezoid(mark) → Section 3.6.2 2 filled Trapezoid(mark) → Section 3.6.2 3 Hat(mark) → Section 3.6.2 4 ● ● → Section 3.6.2 5 ● → Section 3.6.2 6 Filled Triangle(mark) → Section 3.6.2 7 ! → Section 3.6.2 8 anchor(mark) → Section 3.6.2 9 Next → Section 3.6.2	
			1 slash-anchor(mark) → Section 3.6.2 2 circle-dotted line(mark) → Section 3.6.2 3 non-dangerous wreck(mark) → Section 3.6.2 4 ⊙ → Section 3.6.2 5 mariner's event mark(mark) → Section 3.6.2 6 · → Section 3.6.2 7 Wavy line (mark) → Section 3.6.2 8 Solid line (mark) → Section 3.6.2 9 Dashed-dotted line (mark) → Section 3.6.2	
		2 Display Mark Color	1 All → Section 3.6.2 2 White → Section 3.6.2 3 Cyan → Section 3.6.2 4 Blue → Section 3.6.2 5 Green → Section 3.6.2 6 Yellow → Section 3.6.2 7 Pink → Section 3.6.2 8 Red → Section 3.6.2	
		3 Mark Size	→ Section 3.6.2	
		4 Comment Font Size	→ Section 3.6.2	
6 Geodetic	→ Section 3.6.6			
7 File Operations		1 Select Card Slot	→ Section 3.6.5	
		2 Load Mode	→ Section 3.6.5	
		3 Load	→ Section 3.6.5	
		4 Unload	→ Section 3.6.5	
		5 Save	→ Section 3.6.5	
		6 Erase	→ Section 3.6.5	
		7 Card Mark Display	→ Section 3.6.5	

# C.9

## Serviceman Menu

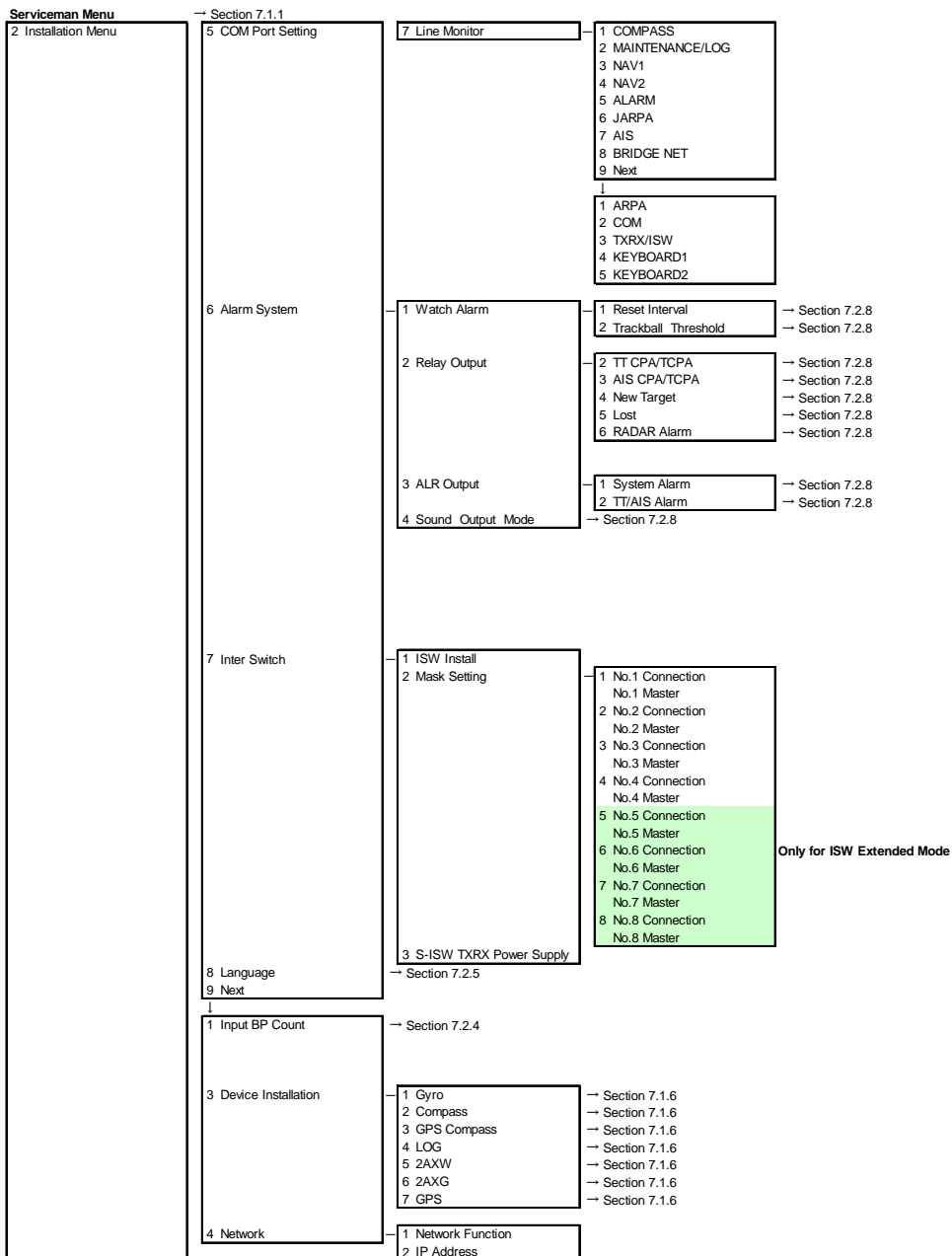
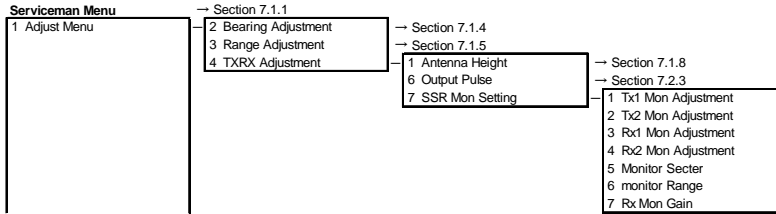

Only for ISW Extended Mode

2 Installation Menu	1 Installation Information	1 Date	→ Section 7.2.7
		2 Name	→ Section 7.2.7
		3 Company	→ Section 7.2.7
	2 Master/Slave	→ Section 7.2.4	
		3 Sector Blank	
	3 Sector Blank	1 Sector1	→ Section 7.2.2
		2 Sector2	→ Section 7.2.2
		3 Sector3	→ Section 7.2.2
		4 Make Sector1	→ Section 7.2.2
		5 Make Sector2	→ Section 7.2.2
		6 Make Sector3	→ Section 7.2.2
	4 CCRP Setting	→ Section 7.1.9	
		5 COM Port Setting	
	1 Baud Rate	1 COMPASS	→ Section 7.2.1
		2 MAINTENANCE/LOG	→ Section 7.2.1
		3 NAV1	→ Section 7.2.1
		4 NAV2	→ Section 7.2.1
		5 ALARM	→ Section 7.2.1
		6 JARPA	→ Section 7.2.1
		7 AIS	→ Section 7.2.1
		8 BRIDGE NET	→ Section 7.2.1
9 Next			
1 ARPA	1 ARPA	→ Section 7.2.1	
	2 COM	→ Section 7.2.1	
2 RX Port	1 GPS	→ Section 7.2.1	
	2 DLOG	→ Section 7.2.1	
	3 Alarm	→ Section 7.2.1	
	4 Depth	→ Section 7.2.1	
	5 Temperature	→ Section 7.2.1	
	6 Wind	→ Section 7.2.1	
	7 Current	→ Section 7.2.1	
	8 ROT	→ Section 7.2.1	
	9 Next		
1 RSA	→ Section 7.2.1		
3 RX Sentence	1 GPS(LL/COG/SOG)	→ Section 7.2.1	
	2 GPS(WPT/TIME)	→ Section 7.2.1	
	3 Depth	→ Section 7.2.1	
	4 Wind	→ Section 7.2.1	
	5 Current	→ Section 7.2.1	
1 Data Set Number	1 Data Set Number	→ Section 7.2.1	
	2 Layer A	→ Section 7.2.1	
	3 Layer B	→ Section 7.2.1	
	4 Layer C	→ Section 7.2.1	
4 TX Port	1 TTM(TT)	→ Section 7.2.1	
	2 TLL(TT)	→ Section 7.2.1	
	3 TTD(TT)	→ Section 7.2.1	
	4 TLB(TT)	→ Section 7.2.1	
	5 OSD	→ Section 7.2.1	
	6 RSD	→ Section 7.2.1	
	7 ALR	→ Section 7.2.1	
	8 ACK	→ Section 7.2.1	
	9 Next		
1 TTM(AIS)	→ Section 7.2.1		
2 TLL(AIS)	→ Section 7.2.1		
3 TTD(AIS)	→ Section 7.2.1		
4 TLB(AIS)	→ Section 7.2.1		
5 Remote Maintenance	→ Section 7.2.1		
6 JRC-ARPA	→ Section 7.2.1		
7 NMEA0183 Output Format	→ Section 7.2.1		
8 NMEA0183 Talker	→ Section 7.2.1		
9 Next			
1 NMEA0183 TX Interval	→ Section 7.2.1		
2 APB	→ Section 7.2.1		
3 BOD	→ Section 7.2.1		
4 GGA	→ Section 7.2.1		
5 GLL	→ Section 7.2.1		
6 RMC	→ Section 7.2.1		
7 RMB	→ Section 7.2.1		
8 VTG	→ Section 7.2.1		
9 Next			
1 XTE	→ Section 7.2.1		
2 BWC	→ Section 7.2.1		
3 HDT	→ Section 7.2.1		
4 THS	→ Section 7.2.1		

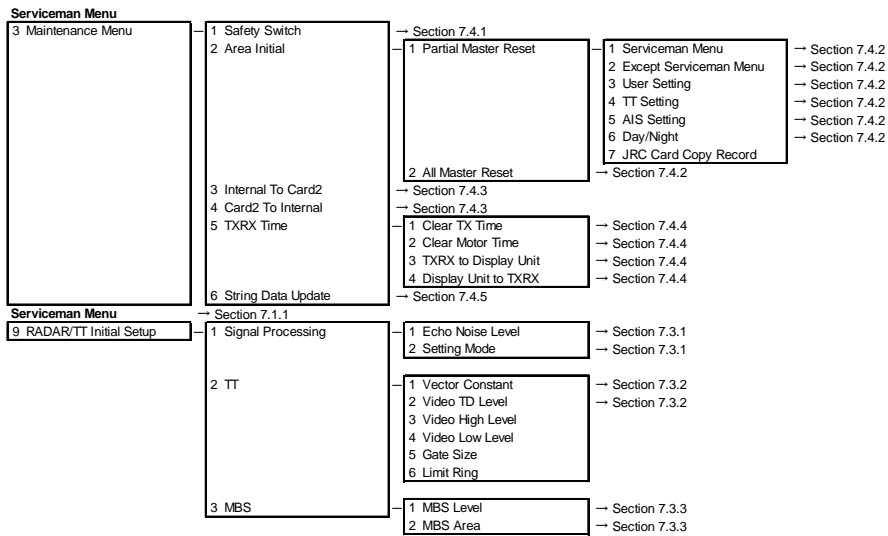







アスベストは使用しておりません  
Not use the asbestos

CODE No.7ZPRD0730

For further information, contact:



Since 1915

*Japan Radio Co., Ltd.*

URL <http://www.jrc.co.jp>

Marine Service Department

Telephone : +81-3-3492-1305

Facsimile : +81-3-3779-1420

e-mail : [tmisc@jrc.co.jp](mailto:tmisc@jrc.co.jp)

AMSTERDAM Branch

Telephone : +31-20-658-0750

Facsimile : +31-20-658-0755

e-mail : [service@jrcams.nl](mailto:service@jrcams.nl)

SEATTLE Branch

Telephone : +1-206-654-5644

Facsimile : +1-206-654-7030

e-mail : [service@jrcamerica.com](mailto:service@jrcamerica.com)

01ETM

ISO 9001, ISO 14001 Certified

©DEC. 2009 Edition 2 JRC

Printed in Japan