

MF/HF Radio Telephone

JSB-196GM

Instruction Manual

JRC *Japan Radio Co., Ltd.*

Preface

Thank you for purchasing the JSB-196GM MF/HF Radio Telephone.

This equipment is installed on small-scale ships for general telecommunications over the high-frequency band.

- Be sure to read this manual for full comprehension before using the equipment.
- Save this manual near at hand for quick reference in the future.
Make use of this manual when experiencing operation difficulties.

Before Operation

Concerning the symbols

This manual uses the following symbols to explain correct operation and to prevent injury or damage to property.



The symbols and descriptions are as follows. Understand them before proceeding with this manual.

 **WARNING** Indicates a warning that, if ignored, may result in serious injury or even death.



 **CAUTION** Indicates a caution that, if ignored, may result in injury or damage to property.

Examples of symbols





The  symbol indicates caution (including DANGER and WARNING). The illustration inside the  symbol specifies the content of the caution more accurately. (This example warns of possible electrical shock.)



The  symbol indicates that performing an action is prohibited. The illustration inside the  symbol specifies the contents of the prohibited operation. (In this example disassembly is prohibited.)



The  symbol indicates operations that must be performed. The illustration inside the  symbol specifies obligatory instructions. (In this example unplugging is the obligatory instruction.)

Concerning warning labels

A warning label is pasted to the top cover of this product.

Do not remove, damage or modify the label.

Handling Precautions

WARNING



Do not disassemble or customize this unit. Doing so may cause fire, electrical shock or malfunction.



Do not use a voltage other than specified. Doing so may cause fire, electrical shock or malfunction.



Do not touch any parts where this warning label is pasted. Doing so may cause electrical shock.

Handling Precautions

CAUTION



Do not use this equipment for anything other than specified. Doing so may cause failure or malfunction.



Do not turn the trimmer resistors or the trimmer capacitors on the PCB unit, except when and if they need to be adjusted. Doing so may cause failure or malfunction. They are preset at the factory.



Do not install this equipment in a place near water or in one with excessive humidity, steam, dust or soot. Doing so may cause fire, electric shock, or malfunction.



Do not insert anything flammable into the ventilation holes. Doing so may cause fire, electric shock or malfunction.



Do not block the ventilation holes. Doing so will cause heat to accumulate, and may cause fire or malfunction.



Do not get this equipment wet or spill any liquids on or near this equipment. Doing so may cause electrical shock or malfunction.



Do not place this equipment anywhere vibration or impact is likely to occur. Doing so may cause a fall or damage to property and persons.



Never touch the antenna terminal, grounding terminal or counterpoise when the JSB-196GM is turned ON. Doing so, may cause electrical shock.



Place Antenna Tuner NFC-196, antenna and counterpoise in position where no one touches them. Doing not so, may cause electrical shock.



Leave installation of this equipment to our repair center or agents. Installation by an unauthorized person may lead to malfunction.

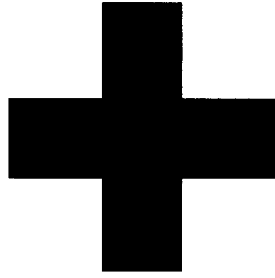

CAUTIONS AGAINST HIGH VOLTAGE

Radio and radar devices are operated by high voltages of anywhere from a few hundred volts up to many hundreds of thousands of volts. Although there is no danger with normal use, it is very dangerous if contact is made with the internal parts of these devices. (Only specialists should attempt any maintenance, checking or adjusting.)

There is a very high risk of death by even a few thousand volts, in some cases you can be fatally electrocuted by just a few hundred volts. To circumvent accidents, you should avoid contact with the internal parts of these devices at all costs. If contact is inevitable as in the case of emergency, you must switch off the devices and ground a terminal in order to discharge the capacitors. After making certain that all the electricity is discharged, only then can you insert your hand into the device. Wearing cotton gloves and putting your free hand in your pocket, in order not to use both hands simultaneously, are also very good methods of shock prevention. Quite often, an injury occurs by secondary factors, therefore it is necessary to choose a sturdy and level working surface. If someone is electrocuted it is necessary to thoroughly disinfect the affected area and seek medical attention as soon as possible.

Cautions concerning treatment of electrocution victims

When you find an electrocution victim, you must first switch off the machinery and ground all circuits. If you are unable to cut off the machinery, move the victim away from it using a non-conductive material such as dry boards or clothing.

When someone is electrocuted, and the electrical current reaches the breathing synapses of the central nervous system inside the brain, breathing stops. If the victim's condition is stable, he or she can be administered artificial respiration. An electrocution victim becomes very pale, and their pulse can be very weak or even stop, consequently losing consciousness and becoming stiff. Administration of first aid is critical in this situation.

First aid

☆Note points for first aid



Unless there is impending danger leave the victim where he or she is, then begin artificial respiration. Once you begin artificial respiration, you must continue without losing rhythm.

- (1) Make contacts with the victim cautiously, there is a risk that you may get electrocuted.
- (2) Switch off the machinery and then move the victim away slowly if you must.
- (3) Inform someone immediately (a hospital or doctor, dial emergency numbers, etc.).
- (4) Lay the victim on his or her back and loosen any constructive clothing (a tie, or belt).
- (5)
 - (a) Check the victim's pulse.
 - (b) Check for a heartbeat by pressing your ear against the victim's chest.
 - (c) Check if the victim is breathing by putting the back of your hand or face near the victim's face.
 - (d) Check the pupils of the eyes.
- (6) Open the victim's mouth and remove any artificial dentifrice, food or chewing gum. Leave the mouth opened and flatten the tongue with a towel or by putting something into the mouth to prevent the victim's tongue from obstructing the throat (If he or she is clenching their teeth and it is difficult to open the mouth, use a spoon or the like to pry open the mouth).
- (7) Continually wipe the mouth to prevent the accumulation of saliva.

☆ **If the victim has a pulse but is not breathing**
(“Mouth to mouth” resuscitation)
Figure 1

- (1) Place the victim’s head facing backward (place something under the neck like a pillow).
- (2) Point the chin upward to widen the trachea.
- (3) Pinch the victim’s nose, take a deep breath, then put your mouth over the victim’s mouth and exhale completely, making sure that your mouth completely covers the victim’s mouth. Then remove your mouth. Repeat this routine 10 to 15 times per minute (holding the nostrils).
- (4) Pay attention to the victim to notice if he or she starts to breath. If breathing returns, stop resuscitation.
- (5) If it is impossible to open the victim’s mouth, put something like a plastic straw or vinyl tube into one of the nostrils then blow air in while covering the mouth and the other nostril.
- (6) Occasionally, when the victim comes back to consciousness, they immediately try to stand up. Prevent this and keep them in a laying position. Give them something warm to drink and be sure that they rest (do not give them any alcohol).

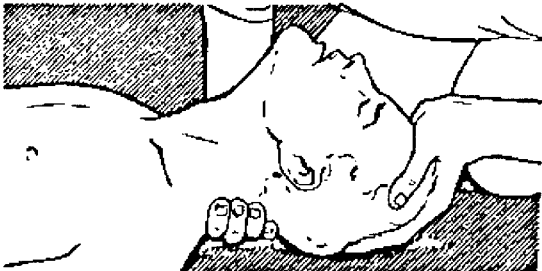
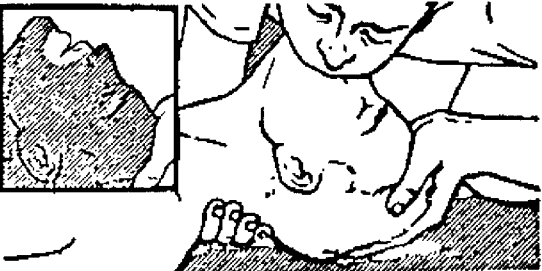
Administering artificial respiration by raising the head.

- | | | |
|---|-------------------------------------------------------------------------------------|------------------------------------------------------------------------------------------------------------------------------------------------------------------------------------------------------------------------------|
| ① |  | <p>(1) Raise the back of head, then place one hand on the forehead and place the other hand under the neck. →①
 Most victims open their mouth when doing this, making “mouth to mouth” resuscitation easier.</p> |
| ② |  | <p>(2) Cover the victim’s mouth by opening your mouth widely, then push your cheek against the victim’s nose, →②
 or pinch the victim’s nose to prevent air from leaking out of it. →③</p> |
| ③ |  | <p>(3) Completely exhale into the lungs. Exhale into the lungs until the chest is inflates. You have to blow as rapidly as possible for the first 10 times.</p> |

“Mouth to mouth” artificial respiration
 Figure 1

**☆ If the victim has no pulse and is not breathing
(Heart massage in combination with artificial respiration.)
Figure 2**

If the victim has no pulse, his or her pupils are dilated, and if you cannot detect a heartbeat, the heart may have stopped, beginning artificial respiration is critical.

- (1) Put both hands on the diaphragm, with hands on top of each other keeping both arms straight (If your elbows are bent, you cannot push with as much power). Press the diaphragm with your body weight until the chest sinks about 2 cm (about 50 times per minute).
- (2) If administering first aid when alone:
Perform the heart massage about 15 times then blow in twice. Repeat this routine.
If administering first aid with two people:
One person performs the heart massage 5 times, and the other person blows air in once. Repeat this routine (Heart massage and "mouth to mouth" resuscitation used together).
- (3) Constantly check the pupils and the pulse, if the pupils become normal and the pulse steadies, keep them in a laying position and give them something warm to drink, be sure that they rest (do not give them any alcohol). In any case you have to entrust major decision making to a doctor. Having understanding people around is essential to the victim's recovery from the mental shock of electrocution.

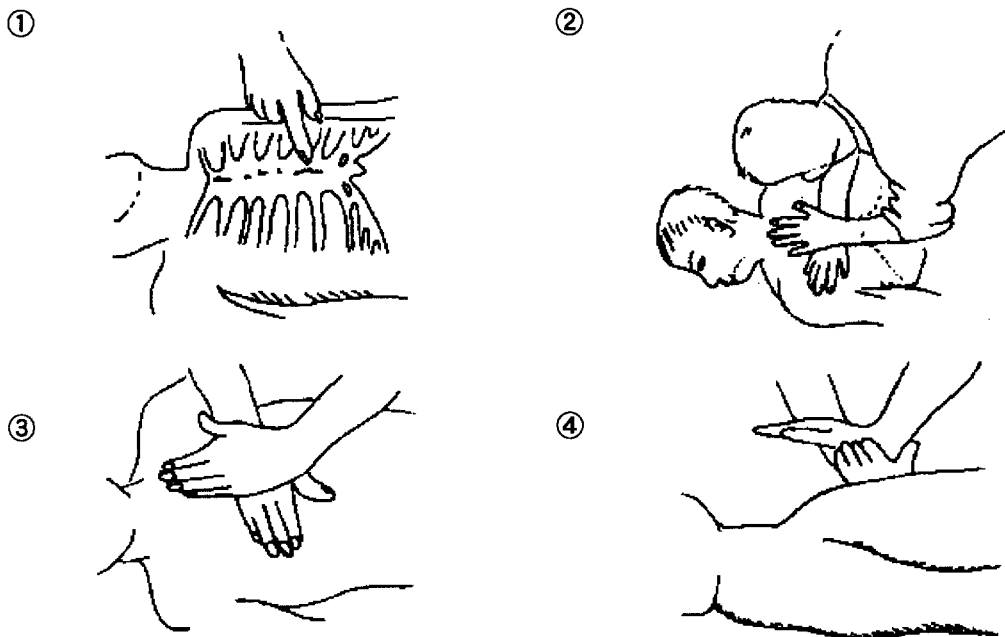

Heart massage in combination with artificial respiration.
Figure 2

DISTRESS CALLS

NCT-196

There are three methods of transmitting a distress call. These are described below. These methods are described in order of ease of use, with the easiest first.

Transmitting Distress Calls 1

Procedure

1. Open the cover on the left and press **DISTRESS** for at least 3 seconds (until the intermittent alarm tone changes to a continuous tone).

The following screen is displayed and the set distress message is transmitted.

The red "DISTRESS/URGENCY" lamp lights while transmitting. (Example: 2187.5kHz)

```
DISTRESS CALL           Transmitting
TX frequency   : 2,187.5 kHz
TX date&time   : 01.Jan.2000(Sat) 19:10
```

Note

- The same distress message is sent 5 times in succession.
- Press **STOP** to cancel the DISTRESS transmission. Note that the transmission stops after transmission of the current message.

2. The distress call transmission is repeated at random intervals of 3.5 to 4.5 minutes.

On completion of the transmission, the following screen is displayed. Transmission of the distress call is repeated when the displayed time has counted down to zero.

```
DISTRESS CALL           2,187.5 kHz
NEXT DISTRESS CALL : AFTER 3.7 min
```

Note

- A distress call is transmitted repeatedly until an acknowledge message is received or the **STOP** key is pressed.

Transmitting Distress Calls 2

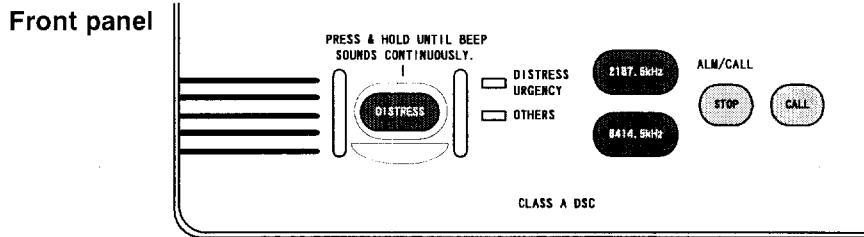

Procedure

1. Press **2187.5kHz** or **8414.5kHz**.

2. Open the cover on the left and press **DISTRESS** for at least 3 seconds (until the intermittent alarm tone changes to a continuous tone).

The following screen is displayed and the set distress message is transmitted.

The red "DISTRESS/URGENCY" lamp lights while transmitting. (Example: 2187.5kHz)

```
DISTRESS CALL           Transmitting
TX frequency           : 2,187.5 kHz
TX date&time           : 01.Jan.2000(Sat) 19:10
```

Note

- The same distress message is sent 5 times in succession.
- Press **STOP** to cancel the DISTRESS transmission. Note that the transmission stops after transmission of the current message.

3. The distress call transmission is repeated at random intervals of 3.5 to 4.5 minutes.

On completion of the transmission, the following screen is displayed. Transmission of the distress call is repeated when the displayed time has counted down to zero.

```
DISTRESS CALL           2,187.5 kHz
NEXT DISTRESS CALL     : AFTER 3.7 min
```

Note

- A distress call is transmitted repeatedly until an acknowledge message is received or the **STOP** key is pressed.
- NATURE OF DISTRESS is fixed as UNDESIGNATED.
- When a navigation aid is connected to the DSC terminal, position and time data are automatically updated, whereby the latest data is transmitted. When a navigation aid is not connected, the position data area blinks during "DSC watching".

Transmitting Distress Calls 3

The NCT-196 enables an operator to create and edit messages for transmission.

Procedure

1. Confirm that the "DSC watching" screen is displayed.

```
DSC Watching 01.jan.2000(SAT) 12:58
N12'34 E123'45 SPEED:12.4KT at 12:57

Self-ID = 000000000 [UTC]
```

2. Press **MENU**.

The "MENU #1-EDIT&CALL" screen is displayed.

```
MENU #1-EDIT&CALL          Select no._
▶ 1.Individual call
  2.Acknowledgement call
  3.Distress call
  4.Distress relay call
  5.Auto/semi-auto call
  6.All ships call
  7.Group call
  8.Area call
  9.Position request
 10.Polling call
 11.Test call
```

Use **▲** and **▼** to scroll the screen.

3. With the "MENU #1-EDIT&CALL" screen displayed, press **3** and then **ENT**.

The "DISTRESS ACK CALL" screen is displayed.

```
DISTRESS CALL          Transmissible
▶ Nature                : UNDESIGNATED DIST
Dist-position          : N31'00 E135'00
Dist-UTC               : 19:10
Dist-telecomm          : J3E TEL
Call TX/RX freq        : 2,187.5/ 2,187.5 kHz
```

Use **▲** and **▼** to scroll the screen.

You can set up the following items on this screen.

```
「Nature」              : UNDESIGNATED DIST
「Dist-position」       : N31'00 E135'00
「Dist-UTC」           : 19:10
「Dist-telecomm」      : J3E TEL
「Call TX/RX freq」    : 2,187.5/ 2,187.5 kHz
```

4. Press **CALL**.

This is DISTRESS messages!!
Press [DISTRESS] key to send.
Press [STOP] key to cancel.

5. Open the cover on the left and press **DISTRESS** for at least 3 seconds (until the intermittent alarm tone changes to a continuous tone).

The following screen is displayed, followed by the transmission of the edited message. The message is transmitted 5 times in succession.

DISTRESS CALL Transmitting
TX frequency : 2,187.5 kHz
TX date&time : 01.Jan.2000(Sat)19:10

On completion of the transmission, the following screen is displayed. Transmission of the distress call is repeated when the displayed time has counted down to zero.

DISTRESS CALL 2,187.5 kHz

NEXT DISTRESS CALL : AFTER 3.7 min

Receiving Distress Calls

When a distress call is received, the "DISTRESS/URGENCY" LED lights up red and the alarm tone sounds. Up to 20 received distress calls are automatically stored in memory for future confirmation. Note, however, that distress messages are automatically deleted 48 hours after they have been received in order to prevent unnecessary distress message relay transmission. Distress messages more than 48 hours old cannot be displayed. This does not indicate a fault in the device.

WARNINGS



When a distress call is received, be sure to inform the ship's captain or officer in charge and log the distress call. There is the possibility of legal repercussions if such a procedure is not followed.

External Views

JSB-196GM MF/HF RADIO TELEPHONE

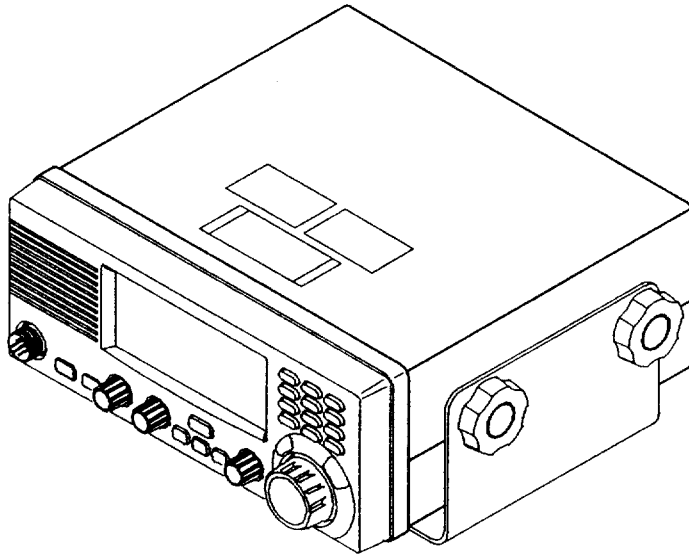

NFC-196 ANTENNA TUNER

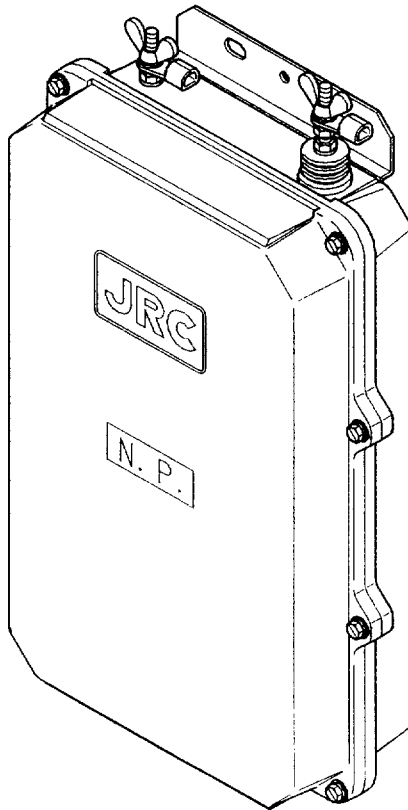

NCT-196 DSC TERMINAL

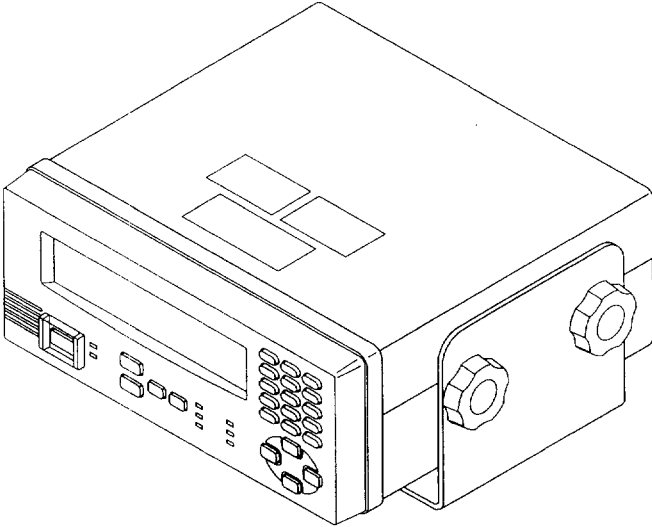

CONTENTS

Preface	i
Before Operation	ii
Handling Precautions	iii
CAUTIONS AGAINST HIGH VOLTAGE	v
Cautions concerning treatment of electrocution victims	v
First aid	vi
DISTRESS CALLS	ix
Transmitting Distress Calls 1	ix
Transmitting Distress Calls 2	x
Transmitting Distress Calls 3	xi
Receiving Distress Calls	xii
External Views	xiii
CONTENTS	xv
Abbreviations	xvii
1.GENERAL	1-1
1.1 Outlines	1-1
1.2 Features	1-1
1.3 Components	1-2
1.3.1 Standard Components	1-2
1.3.2 Options	1-2
1.4 Configuration	1-3
2.PART NAMES AND FUNCTIONS	2-1
2.1 JSB-196GM MF/HF Radio Telephone	2-1
2.1.1 External View	2-1
2.1.2 Operating Panel	2-2
2.2 NFC-196 Antenna Tuner	2-3
3.DISPLAYS	3-1
3.1 LCD Panel of JSB-196GM	3-1
4.CONNECTION DIAGRAM	4-1
4.1 JSB-196GM and NFC-196 Connection	4-1
4.2 JSB-196GM and NCT-196 Connection	4-2
5.OPERATION	5-1
5.1 Turning the Power ON / OFF	5-1
5.1.1 Turning the Power ON	5-1
5.1.2 Turning the Power OFF	5-1
5.2 Communication Procedure	5-2
5.2.1 Setting the channel number with the Jog Dial	5-2
5.2.2 Monitoring the transmission frequency	5-3
5.2.3 Setting the channel number with keypad	5-4
5.2.4 Manually inputting frequency	5-5
5.2.5 Scanning reception	5-6

5.3 Other Function Settings	5-7
5.3.1 Setting the communication mode	5-7
5.3.2 Setting the output power	5-8
5.3.3 Turning the Automatic Gain Control (AGC) ON	5-8
5.3.4 Adjusting squelch Level	5-9
5.3.5 Setting the scanning speed	5-10
5.3.6 Registering the User channel	5-10
5.3.7 Registering a channel group name	5-12
5.3.8 Setting the meter indication mode	5-13
5.3.9 Setting the Automatic Tuning Start (ATS)	5-13
5.3.10 Setting the wait time for ATS	5-14
5.3.11 Turning the key-in sounds ON / OFF	5-14
5.3.12 Setting the loudspeaker output ON / OFF	5-15
5.3.13 List of shortcut keys	5-16
6.MAINTENANCE AND INSPECTION	6-1
6.1 General Maintenance and Inspection	6-1
6.2 Maintenance Function in MENU	6-2
6.2.1 Self Diagnosis	6-2
6.2.2 Firmware-Version Display	6-3
6.3 Troubleshooting	6-4
(1) No receiving sound	6-4
(2) No display on the LCD	6-5
7.AFTER-SALES SERVICE	7-1
Before returning repair	7-1
Periodical maintenance recommended	7-1
8.SPECIFICATIONS	8-1
8.1 JSB-196GM MF/HF Radio Telephone	8-1
(1) General	8-1
(2) Transmitter	8-1
(3) Receiver	8-2
(4) Two-Tone Generator	8-2
8.2 NFC-196 Antenna Tuner	8-2
9.APPENDIX	9-1
9.1 Allocation of ITU Channels	9-1

Abbreviations

ATS:	Automatic Tuning Start
ATU:	Antenna Tuner
DIM:	Dimmer
DSC:	Digital Selective Calling
GMDSS:	Global Maritime Distress and Safety System
HF:	High Frequency
IMO:	International Maritime Organization
ITU:	International Telecommunication Union
MF:	Medium Frequency (300 kHz to 3 MHz)
PC:	Personal Computer
SSB:	Single Side Band

1 . GENERAL

1.1 Outlines

The JSB-196GM is a 150W MF/HF Radio Telephone designed for fishing vessels and other middle or small vessels. The small and lightweight components allow installation at any convenient location on any vessels. SSB radio communication is effectively available with simple operations, continuously covering 1.6 MHz to 27.5 MHz for transmission and 0.1MHz to 29.9999 MHz for reception in 100Hz steps.

1.2 Features

● Simple Installation on Small Ship

Each equipment is of very compact design for simple installation on small ship. The GMDSS-based system consists of the JSB-196GM MF/HF Radio Equipment, the NCT-196 DSC Terminal and a DC-DC converter. The main unit of the JSB-196GM and the NCT-196 can be integrated as a stacked system and installed in a easy-to-operation place on the bridge.

● Simple Operation

The JSB-196GM is designed for user-friendly operation using a single large control dial for routine work, frequency channel selection, mode setting and high/low transmit power switching. The NCT-196 integrates the DSC modem and the watchkeeping receiver in it, enabling operations to fully meet the GMDSS requirement.

● Digital Signal Processing (DSP)

The JSB-196GM Radio Telephone uses 32-bit floating fixed point DSP for digital signal processing in and after the IF stage. The DSP technology improves a number of functions including noise reduction and various types of interference rejection, ensuring enhanced performance.

● Wide Frequency Range

The JSB-196GM covers fully HF marine band, 1.6 to 27.5MHz for transmission and 0.1 to 29.9999MHz for reception in 100Hz steps, and also all ITU channels are factory programmed for ease of use.

● 200 Field Programmable Memory Channels

User definable channels are stored in a non-volatile memory and will be set-up quickly with Jog Dial operation. These channels are freely field programmable into 10 groups for scanning reception of a maximum of 20 channels.

● Self-diagnosis Function

A built-in high grade self-diagnosis facilitates troubleshooting, checking and repairing to ensure easy maintenance.

● High Expandability

The JSB-196GM can provide the HF E-mail communication capability by connecting a dedicated modem and a general-purpose personal computer.

1.3 Components

1.3.1 Standard Components

No.	Component	Part name	Quantity	Remarks
1	MF/HF Radio Telephone	JSB-196	1	
1-1 Included Accessories				
1-1-1	Hand Set	NQW-213	1	
1-1-2	Power Cable	7ZCJD0043	1	L=1m
1-1-3	Mounting screws	MPTG30762	1	
1-1-4	Plug	5JWGC00004	1	
1-1-5	Connector	5JJAJ00034	2	
1-1-6	Terminals	5JDAH00084	2	
1-1-7	Spare fuse	5ZFEX00013	4	40A
1-1-8	Instruction Manual	7ZPJD0108	1	English
1-1-9	Packing List	7ZPJD0119A	1	
1-1-10	Register List	7ZPJD0065	1	
1-1-11	Return Envelope	6ZXJD00122	1	
2	DSC Terminal	NCT-196	1	
2-1 Included Accessories				
2-1-1	DSC Power Cable	7ZCJD0062	1	L=3m
2-1-2	DSC AF Cable	7ZCJD0071	1	L=1.5m
2-1-3	DSC Control Cable	7ZCJD0072	1	L=1.5m
2-1-4	Spare fuse	5ZFEX00012	2	3A
2-1-5	Instruction Manual	7ZPJD0120	1	English
2-1-6	Packing List	7ZPJD0127	1	
3	Antenna Tuner	NFC-196	1	
3-1 Included Accessories				
3-1-1	ATU Control Cable	7ZCJD0044A	1	L=5m
3-1-2	ATU RF Cable	7ZCJD0045	1	L=5m
3-1-3	Screw	BRTG03217	2	
3-1-4	Terminal	5JTCD00393	2	1.25-3
3-1-5	Terminal	5JTCD00001	2	2-3
3-1-6	Terminal	BRTE00395	2	5.5-3
3-1-7	Washer	BSFW06000B	2	W6Bs
3-1-8	Packing List	7ZPJD0126	1	

1.3.2 Options

No.	Component	Part name	Quantity	Remarks
1	DC-DC Converter	NBG-300	1	
2	Hand Microphone	NVT-133	1	
3	Hand Microphone	NVT-140	1	

1.4 Configuration

JSB-196GM MF/HF Radio Telephone

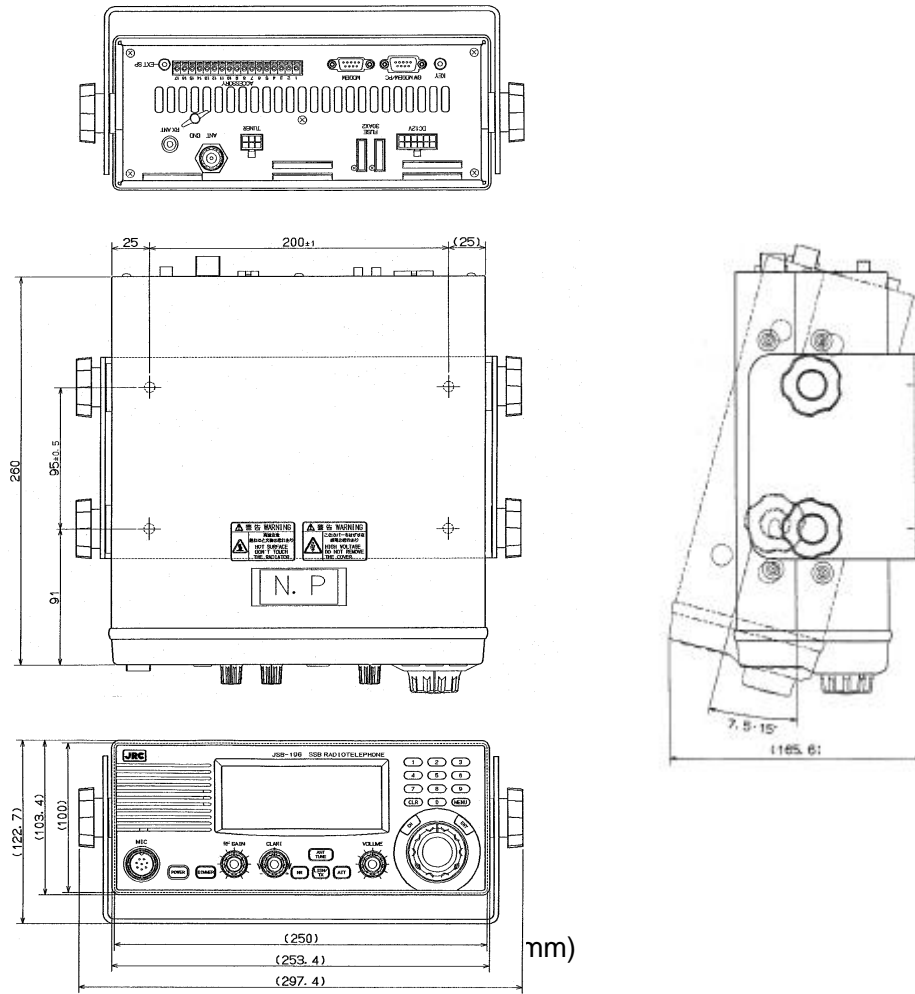

NFC-196 Antenna Tuner

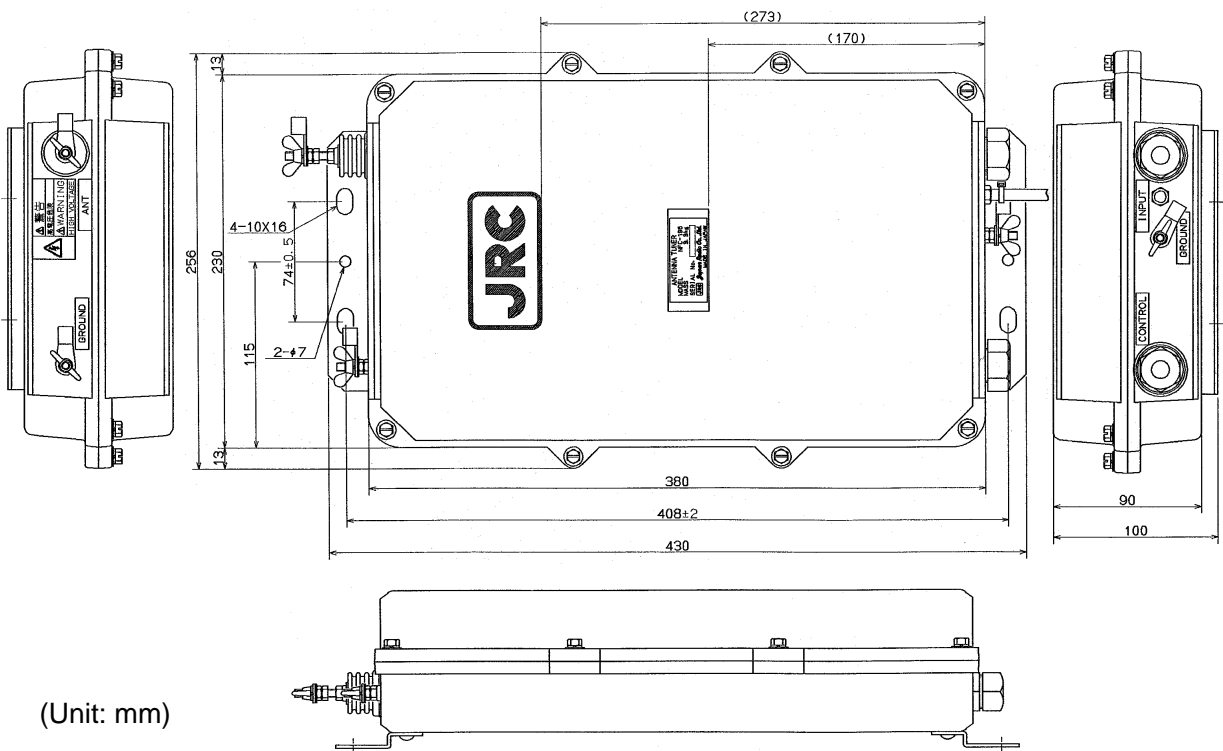

(Unit: mm)

2. PART NAMES AND FUNCTIONS

2.1 JSB-196GM MF/HF Radio Telephone

2.1.1 External View

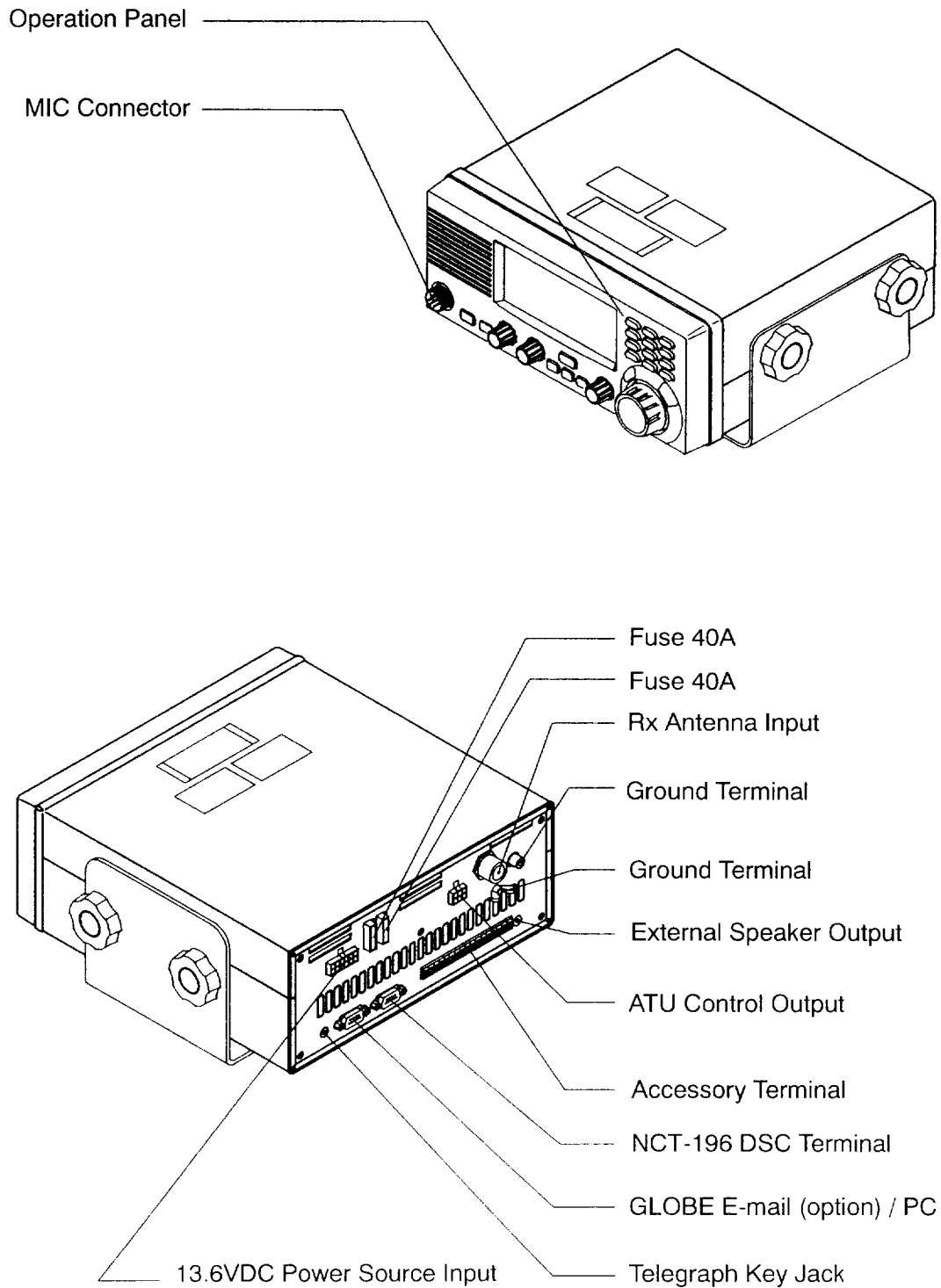

2.1.2 Operating Panel

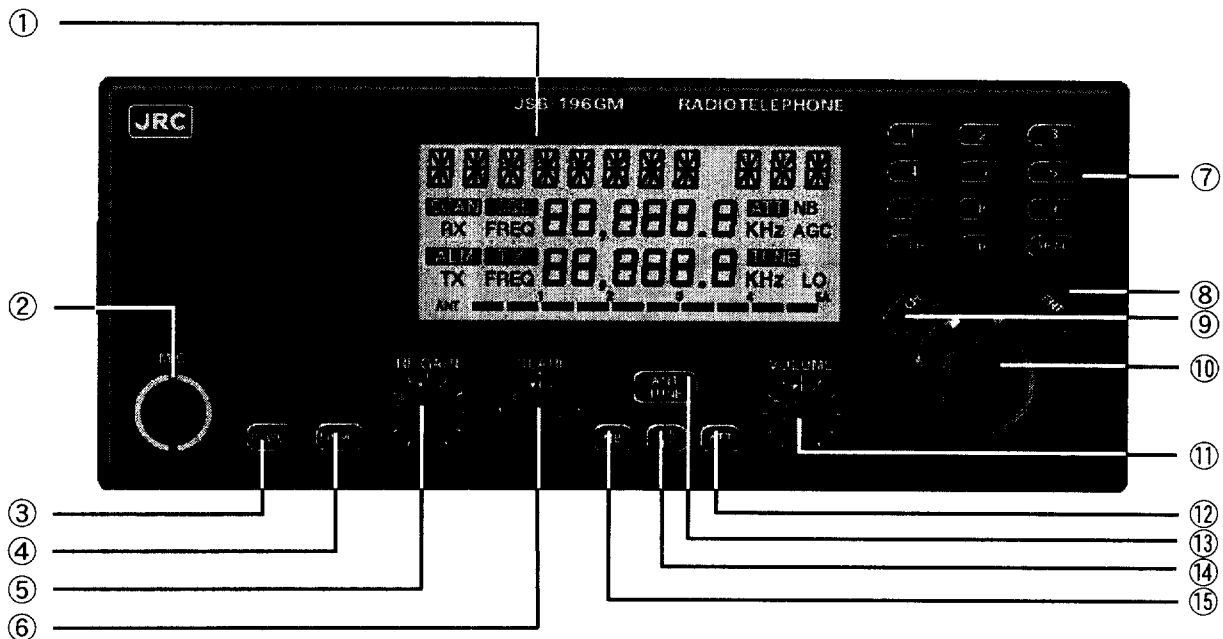

① **Liquid Crystal Display Panel**

② **MIC**
A hand microphone or handset is connected here.

③ **POWER**
Turns power ON or OFF.

④ **DIMMER**
Controls the brightness of the LCD.

⑤ **RF GAIN**
Controls the RF gain.

⑥ **CLARI**
Adjusts the frequency variation, which ranges from -200 to +200Hz in 1Hz steps.

⑦ **0 ~ 9** , **MENU** **CLR**
These buttons are used to input frequency/channel values or to set a menu.

⑧ **ENT**
Enters the input information.

⑨ **CH**
Starts channel selection.

⑩ **Jog Dial**
Used to select a channel or receive frequency or to select a menu.

⑪ **VOLUME**
Controls the sound volume of reception.

⑫ **ATT**
Turns the attenuator ON or OFF.

⑬ **ANT TUNE**
Starts antenna tuning.

⑭ **LISN/TX**
Temporarily monitors the transmission frequency in the Semi-Duplex mode

⑮ **NR**
Reduces pulsating noises.

2.2 NFC-196 Antenna Tuner

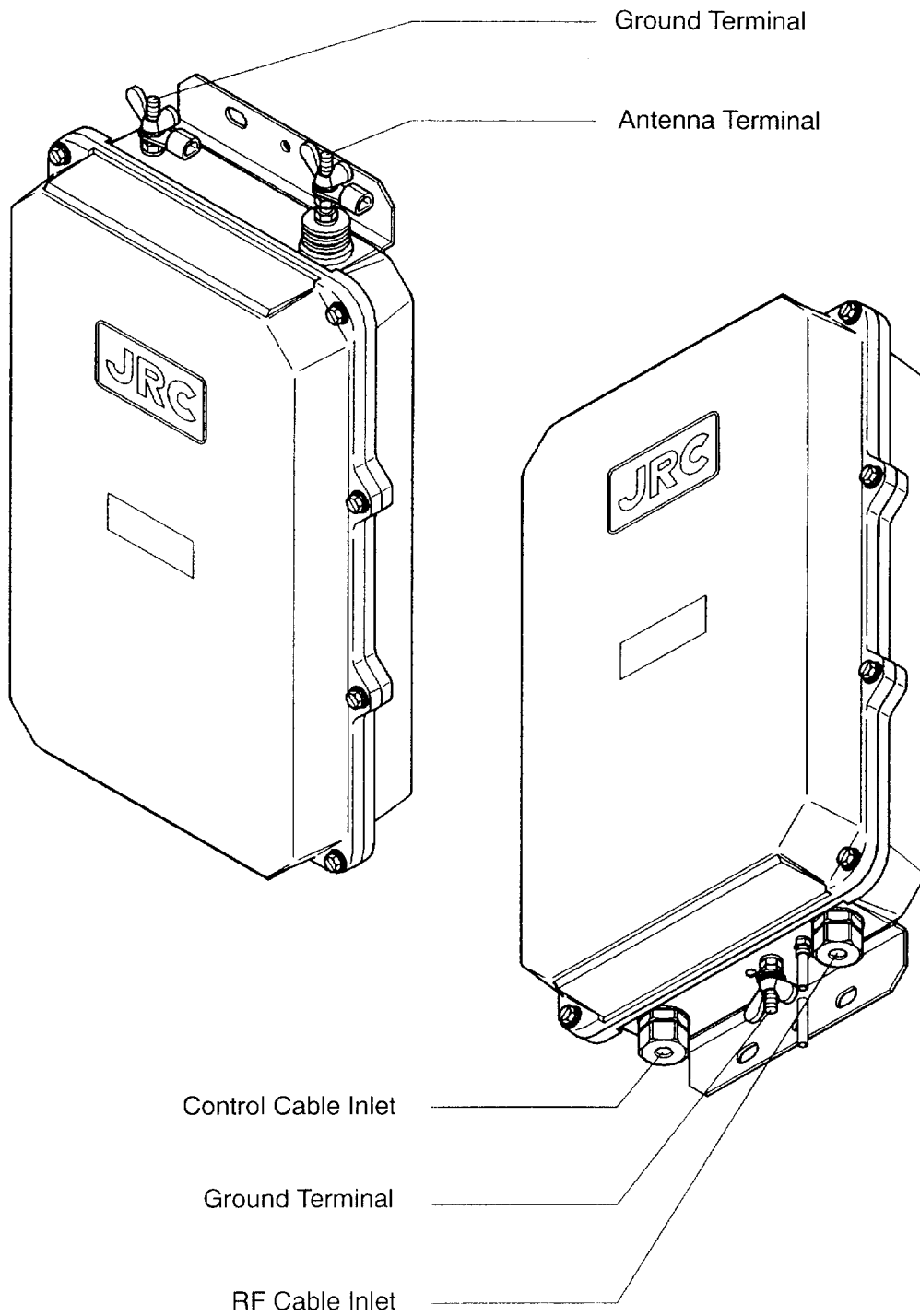

3. DISPLAYS

3.1 LCD Panel of JSB-196GM

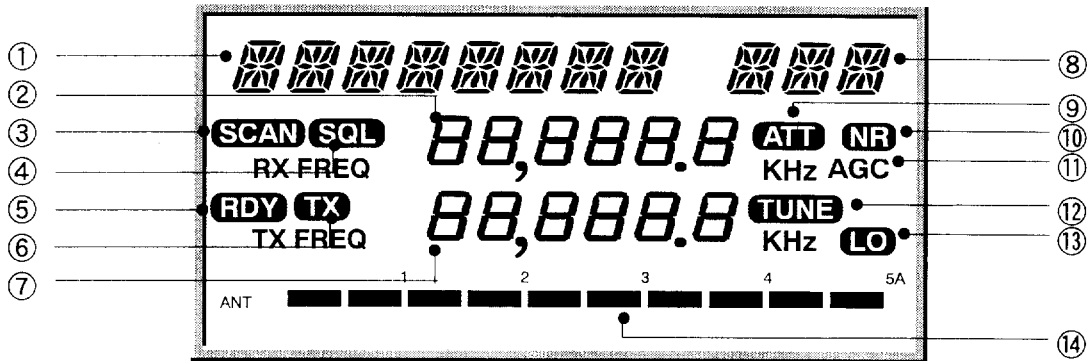

- ① **Channel display field**
User channel number or ITU channel number with channel name is displayed. While a menu function is being set, necessary information responding to the menu item is displayed.
- ② **RX frequency display**
The RX frequency responding to the channel numbers or freely-entered frequency is displayed.
- ③ **SCAN**
Indicates that the scanning reception is in progress.
- ④ **SQL**
Indicates that the squelch closed.
- ⑤ **RDY**
Indicates that transmitting is ready.
- ⑥ **TX**
Indicates the on/off state of transmission.
- ⑦ **TX frequency display**
The TX frequency responding to the channel numbers or freely-entered frequency is displayed.
- ⑧ **Mode display field**
Communication mode is displayed. While a menu function is being set, necessary information responding to the menu item is displayed.

- ⑨ **ATT**
Indicates that the attenuator is ON.
- ⑩ **NR**
Indicates that the noise reduction is ON.
- ⑪ **AGC**
Indicates that the AGC is ON.
- ⑫ **TUNE** (Blinking)
Indicates that the antenna tuner is required.
TUNE
Indicates that the antenna tuner is tuning.
- ⑬ **LO**
Indicates that the transmission output is reduced to low power level.
- ⑭ **Meter**
During reception, the stronger the signal, the more bar appears. The output power or antenna current appears during transmission.

4. CONNECTION DIAGRAM

⚠ CAUTION



Leave installation of this equipment to our service center or agents. Installation by an unauthorized person may results in malfunction.

4.1 JSB-196GM and NFC-196 Connection

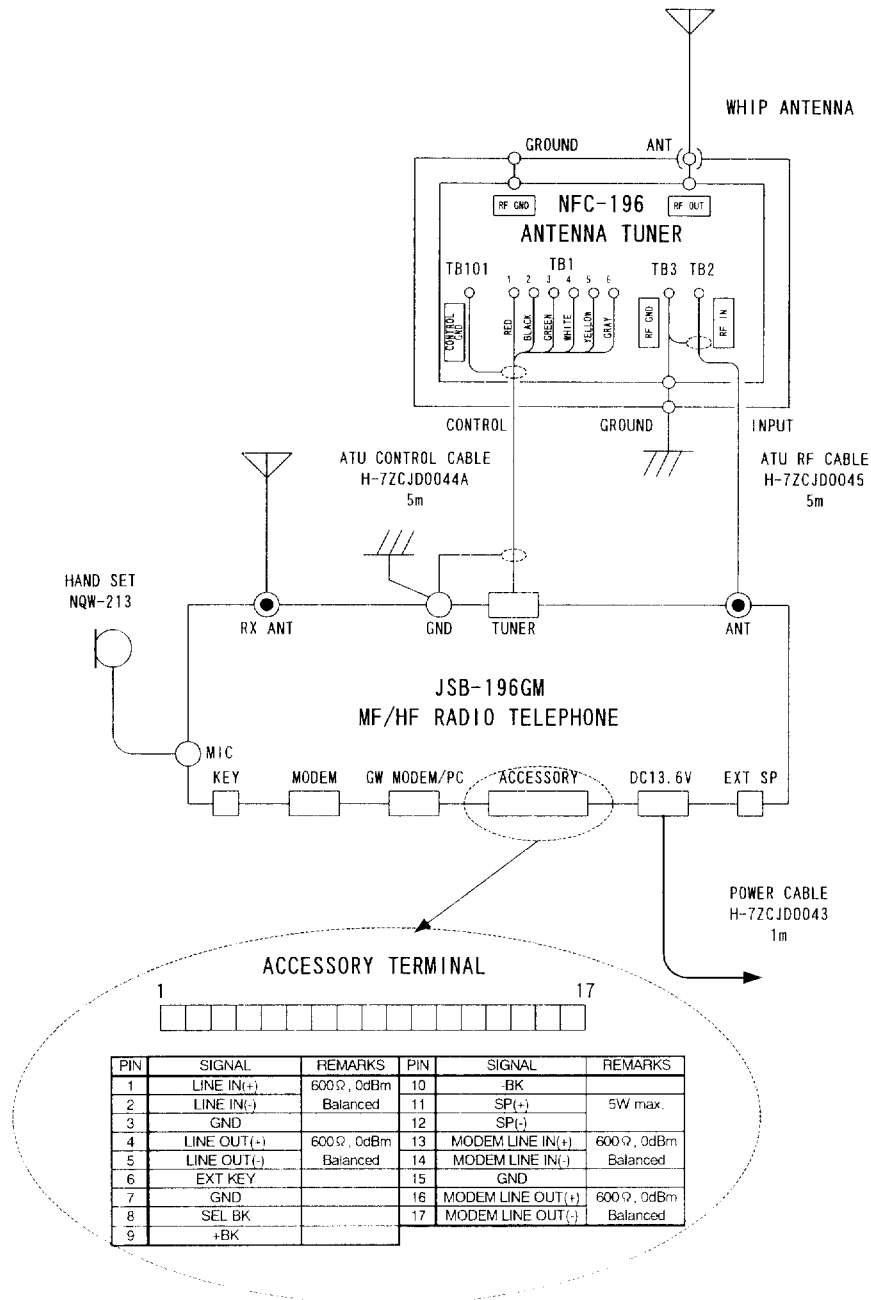

4.2 JSB-196GM and NCT-196 Connection

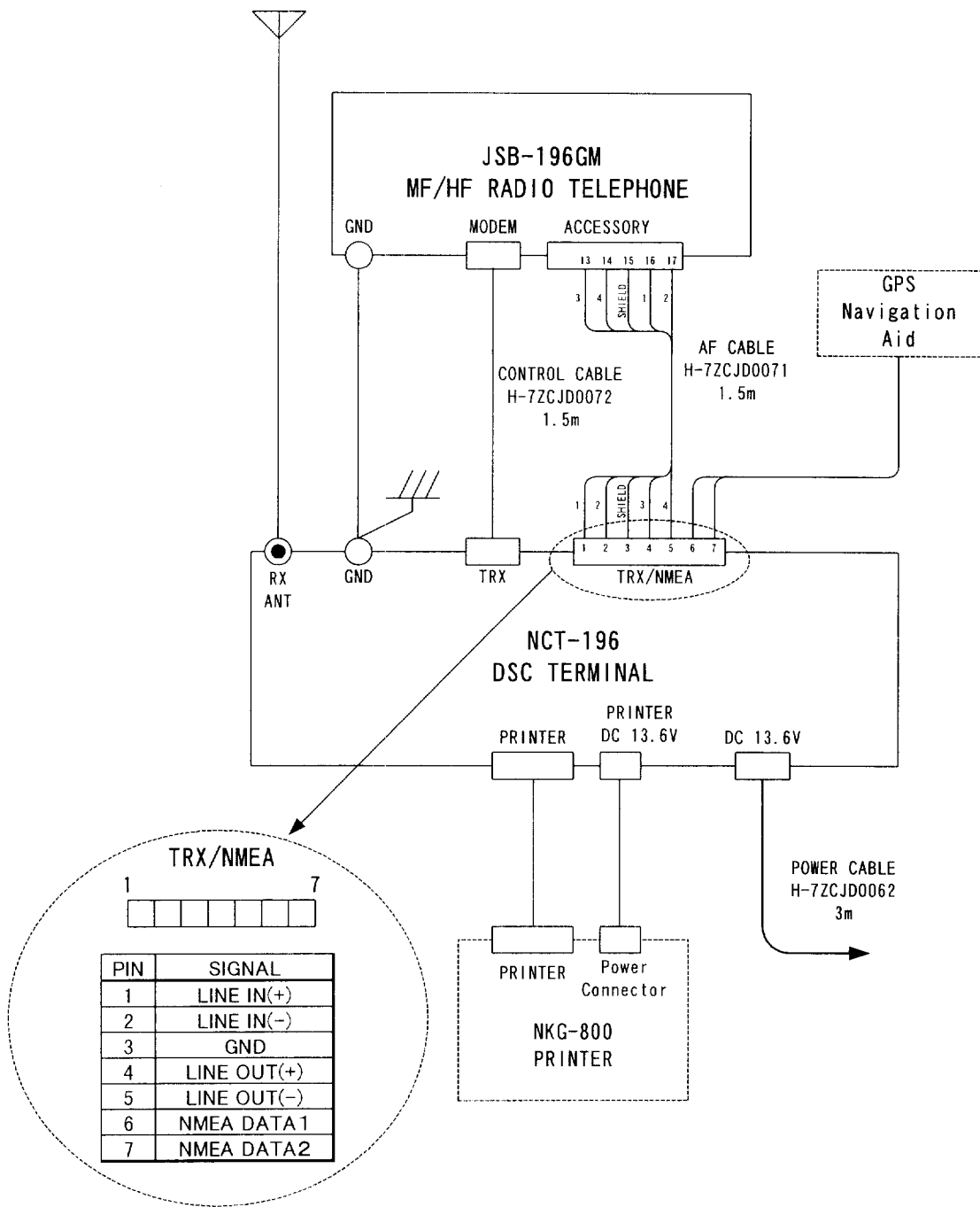



5. OPERATION

5.1 Turning the Power ON / OFF

CAUTION



Never touch the antenna terminal, grounding terminal or counterpoise when the JSB-196GM is turned ON. Doing so, may cause electrical shock.



Place Antenna Tuner NFC-196, antenna and counterpoise in position where no one touches them. Doing not so, may cause electrical shock.

5.1.1 Turning the Power ON

Press **POWER** on the front panel until the channel and frequencies are displayed as follows:

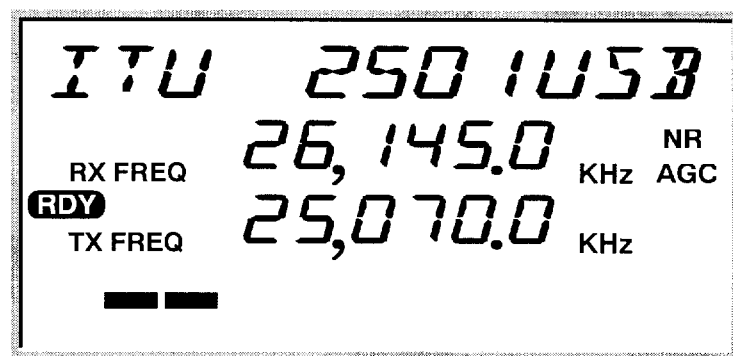

Figure 5.1 Initial display on the LCD (immediately after the equipment is powered on)

5.1.2 Turning the Power OFF

Press **POWER** until LCD disappears.

Note

The latest channel / frequency and set-up state information such as communication mode are stored in memory when the equipment is turned OFF. It will be set automatically when the equipment is powered on again except the following items and these items will be set to as follows:

- Built-in loudspeaker ON/OFF (ON as default)
- Squelch value (0 as default)

5.2 Communication Procedure

The JSB-196GM employs the Jog Dial for simply setting or selection for principal functions such as TX/RX frequency, communication mode, output power, squelch, AGC, etc. and the following procedures are provided for pleasant communication.

5.2.1 Setting the channel number with the Jog Dial

User/ITU channels can be set with the Jog Dial.

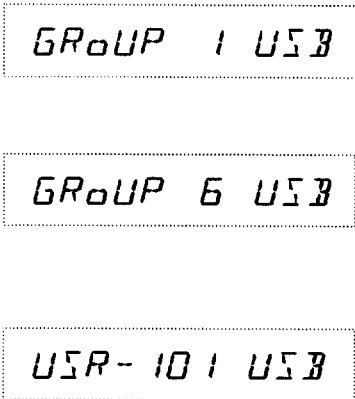
Procedure	Examples of display on the LCD
<p>Example of user channel number 101</p> <ol style="list-style-type: none">1. Press <input type="button" value="CH"/>. "GROUP 1 USB" appears in the channel field of the LCD.2. Turn Jog Dial. ^(*) Turn the Jog Dial until the group number, ex. "GROUP 6 USB", including the objective channel number is displayed.3. Press <input type="button" value="ENT"/>. User channel number is displayed.4. Turn Jog Dial again until the objective number, "USR-101" is displayed. If <input type="button" value="TUNE"/> is blinking, press <input type="button" value="ANT TUNE"/>. <input type="button" value="TUNE"/> lights steadily during tuning, and disappear when tuning is completed.5. Press <input type="button" value="ENT"/>. The selected channel number is fixed.	<p>(in the USB mode)</p>  <p>The LCD display shows the channel selection process. It starts with 'GROUP 1 USB', then 'GROUP 6 USB', and finally 'USR-101 USB'. Below these, a detailed LCD display is shown with 'USR-101 USB' at the top. The RX FREQ is 26,145.0 KHz and the TX FREQ is 25,070.0 KHz. The 'RDY' indicator is lit, and the 'TUNE' indicator is blinking. An arrow points to the 'TUNE' indicator.</p>

Procedure

6. With these steps, the JSB-196GM is ready to communicate. Start communication by pressing PTT on the hand set for radiotelephone or by telegraph key for morse radiotelegraph.

Examples of display on the LCD

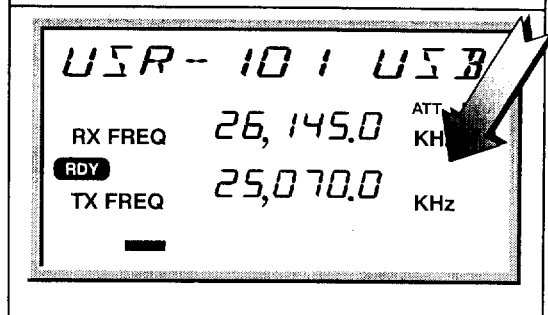

Note

To set an ITU channel, turn the Jog Dial until an ITU channel is displayed at step2, then execute the following steps as same as the user channel.

- ① Turn the Jog Dial until the band number, ex. 401, 601, 801, and so on, including the objective channel number is displayed and press
- ② Turn the Jog Dial until the objective channel is displayed, then press and go to step 5.

*1 For easy selection of a channel number, you can allocate an identification label to each channel (See "5.3.6 Registering a user channel").

5.2.2 Monitoring the transmission frequency

In semi-duplex mode the TX/RX frequency are set differently, though only one way transmission or reception is possible at the same time. The transmission frequency signal can be checked for interference.

Procedure

1. Press

JSB-196 starts to receive TX frequency. After the check, press again or transmit to return to the initial state.

5.2.3 Setting the channel number with keypad

USR/ITU channel number can be set with keypad as follows.

Procedure

Example of user channel number 101

1. Press **CH**.

"GROUP 1 USB" appears in the channel field of the LCD.

2. Press **1**, **0** and **1**.

The channel number is displayed in the channel field of the LCD.

3. Press **ENT**.

The input channel number is fixed.

4. If **TUNE** is blinking, press **ANT TUNE**.

TUNE lights steadily during tuning, and disappears when tuning is completed.

5. With these steps, the JSB-196GM is ready to communicate. Start communication by pressing PTT on the Hand set for radiotelephone or by telegraph key for morse radiotelegraph.

Examples of display on the LCD

(in the USB mode)



GRoUP 1 USB



CH- 101 USB

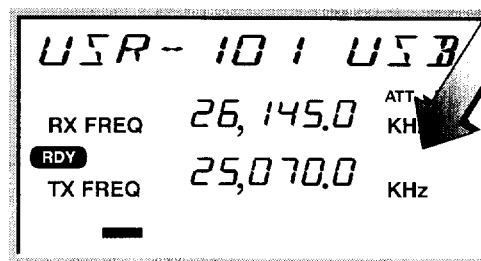
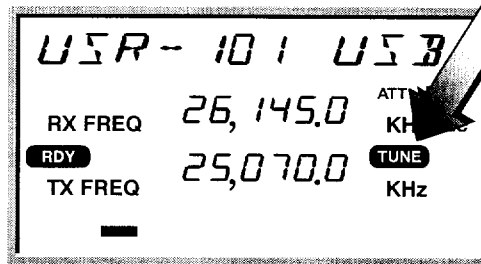

5.2.4 Manually inputting frequency

In this case, communication mode must be set in advance (For setting of a radio mode, see "5.3.1 Setting a communication mode"). TX and RX frequency can be set with keypad as follows.

Procedure

Example of RX frequency 4357.0 kHz / TX frequency 4065.0 kHz.

1. Press , , , and for the RX frequency. The RX frequency is displayed in the channel field of the LCD.

2. Press .

The RX frequency is fixed. When you want to use this frequency also as a TX frequency, press again.

3. Press , , , and for the TX frequency. The TX frequency is displayed in the channel field of the LCD.

4. Press .

The TX frequency is fixed.

5. If is blinking, press .

lights steadily during tuning, and disappear when tuning is complete.

6. With these steps, the JSB-196GM is ready to communicate. Start communication by pressing PTT on the Hand set for radiotelephone or by telegraph key for morse radiotelegraph.

Examples of display on the LCD

(in the USB mode)

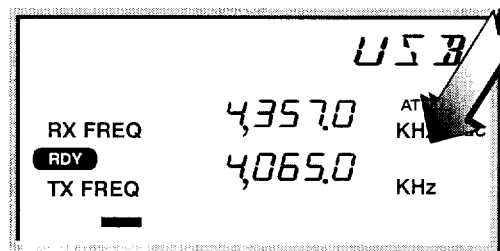
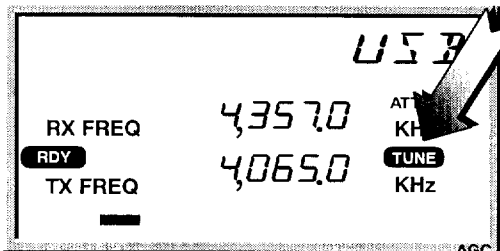
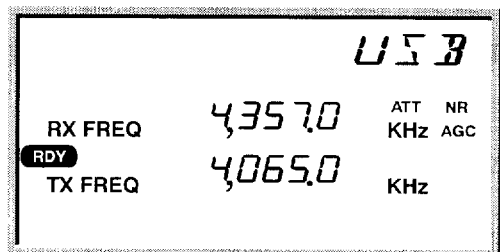
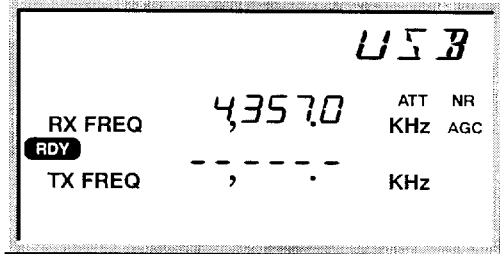

5.2.5 Scanning reception

The reception frequency stored in user channel group 1 to 10, each 20 channels can be scanned. You can select a desired group (20 user channels per group) for scanning.

Procedure

Example of group 7.

1. Press **MENU**, then turn the Jog Dial until "SCAN" appears in the channel field of the LCD.

2. Press **ENT**.

"Group 1 1" appears in the channel field of the LCD.

3. Turn the Jog Dial until objective group is displayed.

4. Press **ENT**.

Scanning reception starts.

SCAN appears on the center left of the LCD. The group name and number which are scanned are displayed in the channel field of the LCD.

5. To cancel scanning, press **CLR**. The last communication mode and the frequencies are set.

Examples of display on the LCD

(in the USB mode)

MODE USB

SCAN 5

GROUP 1 1

GROUP 7 7



- Note**
- For easy selection of a scanning group, you can allocate an identification label to each group (See "5.3.7 Registering a channel group name").
 - In addition to the above operation, you can also use a shortcut key to execute scanning reception. For using a shortcut key, see "5.3.13 List of shortcut keys" (Shortcut key number: 5).

5.3 Other Function Settings

The function setting is basically executed by using **MENU** key and the Jog Dial, and the settable items blinks and is set with **ENT** key.

5.3.1 Setting the communication mode

In the use of manually inputting frequency, communication mode must be set in advance.

Procedure

Example of A1A.

1. Press **MENU** .
"MODE" in the channel field of the LCD blinks.
2. Press **ENT** .
The current communication mode "USB" blinks.
3. Turn the Jog Dial.
Turn the Jog Dial until objective mode. "A1A" is blinking.
4. Press **ENT** .
A1A is fixed as communication mode.
5. If **TUNE** is blinking, press **ANT TUNE** .
TUNE lights steadily during tuning. and disappear when tuning is complete.

Examples of display on the LCD

(in the USB mode)

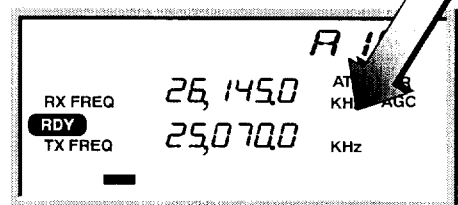
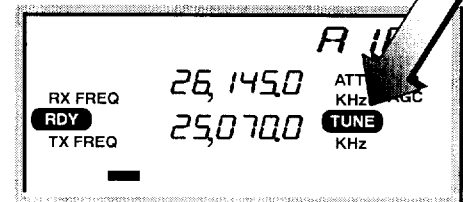
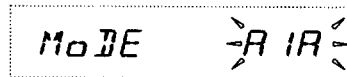
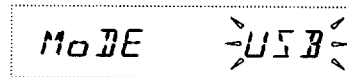
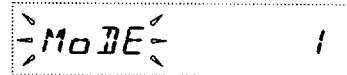

5.3.2 Setting the output power

The output power can be set to "HI(150W)" or "LOW(50W)".

Procedure

1. Press **MENU**, then turn the Jog Dial until "Power" in the channel field of the LCD blinks.
 2. Press **ENT**.
- The current out power "HI" blinks.
3. Turn the Jog Dial until "LOW " blinks.
 4. Press **ENT**.

The output power is set to "LOW ".
LO on the lower right corner of the LCD turns on.

Examples of display on the LCD

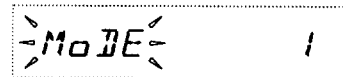

MODE 1

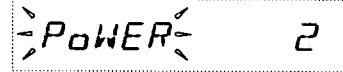

POWER 2

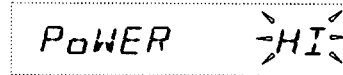

POWER HI

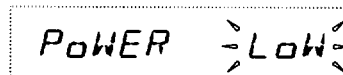

POWER LOW

5.3.3 Turning the Automatic Gain Control (AGC) ON

The AGC circuit functions to maintain a constant receiver output by automatically adjusting the gain according to the strength of the reception signals.

Procedure

1. Press **MENU**, then turn the Jog Dial until "AGC" in the channel field blinks.
 2. Press **ENT**.
- The current AGC status "SLW" blinks.
3. Turn the Jog Dial until desirable state "FST" or "OFF" appears.
 4. Press **ENT**.

The desirable "AGC" state is fixed.

AGC on the center right corner of the LCD turns on when you set to "SLW" or "FST".

Examples of display on the LCD

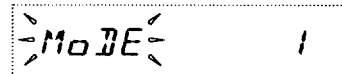

MODE 1



AGC 3



AGC SLW



AGC FST

5.3.4 Adjusting squelch level

The squelch circuit functions to mute received signals based on its level. The larger the squelch level, the larger the antenna input level is required to open the squelch circuit. When the squelch circuit is activated (mute status), **SQL** in the LCD turns on.

Procedure

1. Press **MENU**, then turn the Jog Dial until "SQUELCH" blinks.

2. Press **ENT**.

The current squelch level "0" blinks.

3. Turn the Jog Dial until desired squelch level appears. When turn the Jog Dial, the bar on the bottom of the LCD expands to indicate the squelch level.

4. Press **ENT**.

The squelch level is fixed.

Examples of display on the LCD

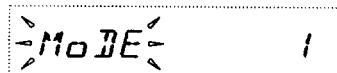

MODE 1

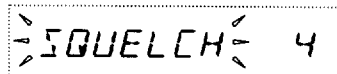

SQUELCH 4



SQUELCH 0

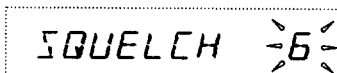

SQUELCH 6

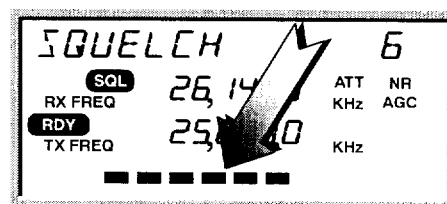

SQUELCH 6
SQL 26.14 ATT NR
RDX 25.10 KHz AGC
TX FREQ KHz

5.3.5 Setting the scanning speed

The scanning time for each channel is settable between 3 to 50 in multiple of 0.1 second.

Procedure

Example of 0.3 seconds.

1. Press **MENU**, then turn the Jog Dial until "SCAN SPD" blinks.

2. Press **ENT**.

The current value "10" blinks.

3. Turn the Jog Dial until desirable scanning time appears or manually input the value from keypad.

4. Press **ENT**.

The scanning time is fixed to 0.3 seconds.

Examples of display on the LCD

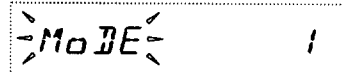

MODE 1

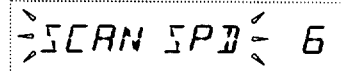

SCAN SPD 6

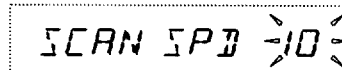

SCAN SPD 10

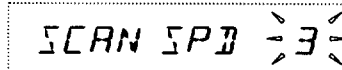

SCAN SPD 3

5.3.6 Registering the User channel

ITU channel/frequency that you use frequently can be registered as a user channel up to 200, channel number 1 to 200.

Procedure

Example of ITU channel number 1207.

1. Make sure that a objective communication mode is set and press **MENU** and then turn the Jog Dial until "USR MEMO" blinks.

2. Press **ENT** ^(*).

"USR MEMO" lights steadily and the user channel registration mode is set.

3. Press **CH**.

"4M" blinks.

Examples of display on the LCD

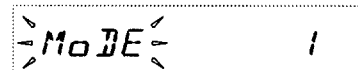

MODE 1

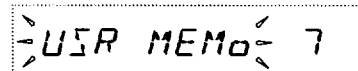

USR MEMO 7



USR MEMO 7

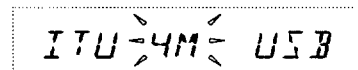

ITU 4M USR

Procedure

4. Turn the jog dial until objective ITU channel band appears.
5. Press .
The channel number "1201" appears.
6. Turn the Jog Dial until objective channel number appears.
7. Press .
The Channel Label Registration mode is set.
(*2)
8. Select an alphabet or number with the Jog Dial.
After selection, press or to fix it.
9. Input a channel number between 1 to 200 with keypad or Jog Dial.
10. Press .
Go to step 3 for further registering or press to exit.

Examples of display on the LCD

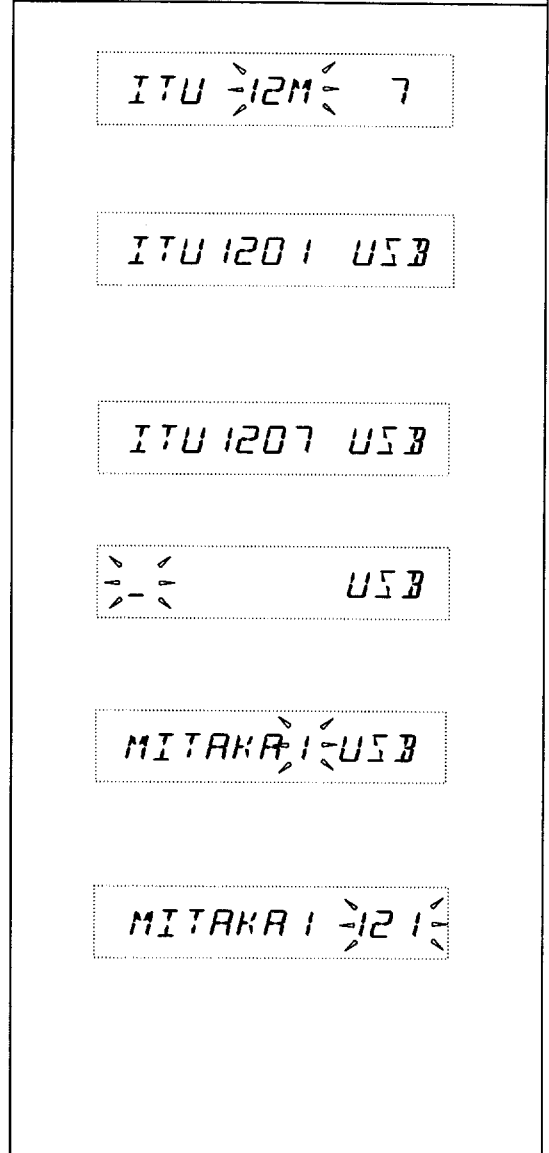

- Note** *1 In step 2, the frequency can be inputted manually. RX frequency and a TX frequency in this order and go to step 8 (When you want to use an identical frequency for reception and transmission, press only after inputting RX frequency).
- *2 In step 7, you do not want a label, press and go to step 9.

5.3.7 Registering a channel group name

200 user channels are grouped into 10 groups, each 20 channels. These groups are used for scanning reception, and can be named for quick selection.

Procedure

1. Press **MENU**, then turn the Jog Dial until "GRP MEMO" blinks.
2. Press **ENT**.
A group number "1" blinks in the right end of the channel field of the LCD.
3. Turn the Jog Dial until the objective group appears.
4. Press **ENT**.
"_" blinks.
5. Repeat to select an alphabet or number with the Jog Dial, and press **ENT** eight times.
After selection of inputting the name, press **ENT** or **CLR** to fix it.
6. Press **ENT**.
Go to step 3 for further registering or press **CLR** to exit.

Examples of display on the LCD

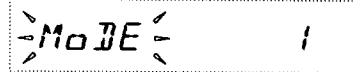

MODE 1



GRP MEMO B



GROUP 1

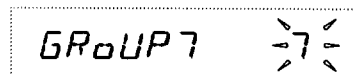

GROUP 7



_ 7

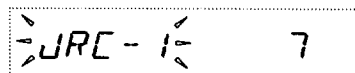

JRC-1 7

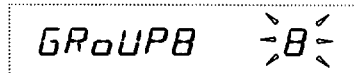

GROUP B

5.3.8 Setting the meter indication mode

The bar indicator on the bottom of the LCD indicates signal level during reception or output during transmission, furthermore output indication is settable to the output power mode or antenna current mode.

Procedure

1. Press **MENU**, then turn the Jog Dial until "METER" blinks.
2. Press **ENT**.
"VF" blinks.
3. Turn the Jog Dial until desired mode appears.
"VF" : Indication for output power.
"IA" : Indication for antenna current.
4. Press **ENT**.
Indication mode, "VF" or "IA", is fixed.

Examples of display on the LCD

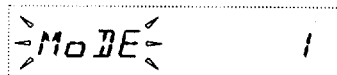

MODE 1

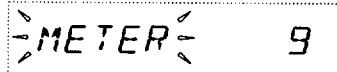

METER 9

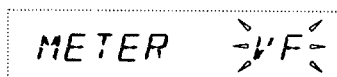

METER VF

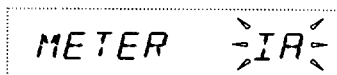

METER IA

5.3.9 Setting the Automatic Tuning Start (ATS)

The ATS function is used for pre-tuning at change of channel / frequency, and tuning starts automatically when the standing-wave ratio (SWR) is wrong.

Procedure

1. Press **MENU**, then turn the Jog Dial until "ATS" blinks.
2. Press **ENT**.
"OFF" blinks.
3. Turn the Jog Dial to set "ON" or "OFF".
4. Press **ENT**.
The ATS function is turned "ON" or "OFF".

Examples of display on the LCD

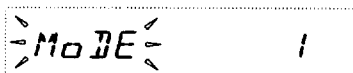

MODE 1



ATS 10



ATS OFF

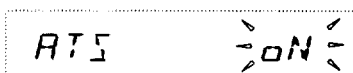

ATS ON

5.3.10 Setting the wait time for ATS

On the ATS function, wait time for tuning start after change of channel / frequency is adjustable.

Procedure

1. Press **MENU**, then turn the Jog Dial until "ATS WAIT" blinks.
2. Press **ENT**.
"1" blinks.
3. Turn the Jog Dial to select the time or manually input the time with keypad.
4. Press **ENT**.
The wait time is fixed.

Examples of display on the LCD

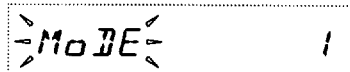

MODE 1

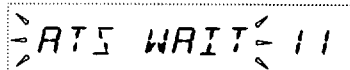

ATS WAIT 11

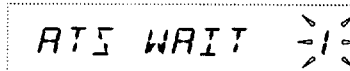

ATS WAIT 1

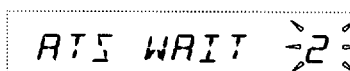

ATS WAIT 2

5.3.11 Turning the key-in sounds ON / OFF

The key-in sounds are available for keypad operation.

Procedure

1. Press **MENU**, then turn the Jog Dial until "BEEP" blinks.
2. Press **ENT**.
"BEEP" lights steadily and "ON" blinks.
3. Turn the Jog Dial to select "ON" or "OFF".
4. Press **ENT**.
The key-in sounds are turned "ON" or "OFF".

Examples of display on the LCD

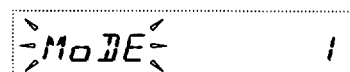

MODE 1

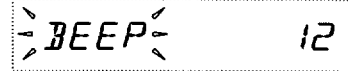

BEEP 12

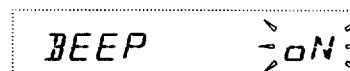

BEEP ON

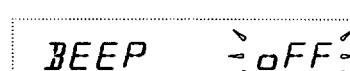

BEEP OFF

Note

The key-in sounds are suspended, when set the loudspeaker OFF.

5.3.12 Setting the loudspeaker output ON / OFF

The loudspeaker output can be turned OFF.

Procedure

1. Press **MENU**, then turn the Jog Dial until "SPEAKER" blinks.
2. Press **ENT**.
"SPEAKER" lights steadily and "ON" blinks.
3. Turn the Jog Dial to select "ON" or "OFF".
4. Press **ENT**.
The loudspeaker output is turned "ON" or "OFF".

Examples of display on the LCD

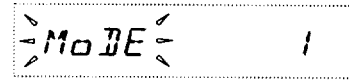

MODE 1



SPEAKER 13



SPEAKER ON



SPEAKER OFF

5.3.13 List of shortcut keys

The following shortcut keys are provided for easy selection of menu items.

Using a shortcut key: The expression "1. Press **MENU**, then turn the Jog Dial" in the above procedure steps can be substituted by " Press **MENU** and input its shortcut key number with keypad".

Menu item	Shortcut key number	Function
Radio mode	1	Selects a communication mode (USB, LSB, H3E, A1A, or F1B).
Low output power	2	Sets the output power to low (50 watts).
AGC	3	Turns ON / OFF the AGC (Auto Gain Control) function.
Squelch level	4	Adjust the squelch level.
Scan	5	Scans the reception frequencies in the selected scanning group.
Scan speed	6	Sets the scanning time.
Registration of the user channel	7	Registers the user channel.
Registration of the channel group name	8	Registers the channel group name.
Bar meter	9	Selects antenna current (IA) or output power (VF) mode.
ATS function	10	Turns ON / OFF the ATS (Automatic Tuning Start) function.
ATS wait time	11	Sets the wait time for the ATS function.
Beeps	12	Turns ON / OFF the key-in sound panel.
Loudspeaker	13	Turns ON / OFF the output of the built-in loudspeaker.
Self Diagnosis	14	Starts the Self Diagnosis function.
Version	15	Display the firmware-version on Control unit CDJ-1960, DSP and NFC-196.

6. MAINTENANCE AND INSPECTION

The performance and longevity of this equipment depend on careful maintenance. To maintain the best performance, the following periodic inspections are highly recommended.

- (1) Keep the power supply voltage within the specified value.
- (2) Know the condition of normal status when the equipment is properly functioning. Keep comparing the current status to the normal status to immediately detect any malfunctions.

WARNING



With the exception of qualified service personnel, do not attempt to service the interior of this equipment, as doing so may cause fire, electric shock or malfunction.

Each internal circuit has been fine-tuned, therefore be sure not to tune or modify without measuring instruments. If any malfunctions are detected, contact our service center or agents.

6.1 General Maintenance and Inspection

Below are listed general maintaining and inspecting items which can be done with usual tools and apparatus.

No.	Item	Maintenance and inspection
1	Cleaning	Gently clean the surface of the panel, knobs, switches, and upper/bottom cover with a soft cloth or silicon oil. Remove dust in the unit using a brush or vacuum cleaner. No oil is needed because this unit has no moving mechanisms inside.
2	Looseness of parts	Inspect for looseness and correctly tighten the following: screws, nuts, knobs, switches, volume pots, connectors and relays inserted into sockets.
3	Fuse	If the power source fuse is blown, be sure to inspect the cause before replacing the blown fuse with a new one.
4	PCB Unit	Remove screws mounting the unit, demount the unit from the main chassis, and inspect the unit for discoloration and parching of components. To exchange parts, call our service center or agents.

Note





If you remove the PCB unit, be sure to store it in a non-conductive bag.
If you wrap it up with materials such as aluminum, the buck-up power supply may short circuit and the IC may be damaged.

6.2 Maintenance Function in MENU

The JSB-196GM has the self diagnosis and firmware-version displaying function for maintenance.

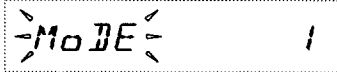
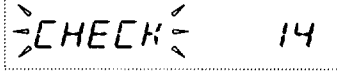
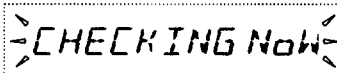
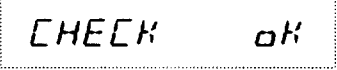
6.2.1 Self Diagnosis

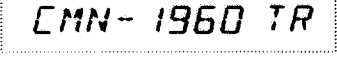
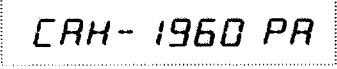
The Self Diagnosis function checks whether the internal circuit is functioning correctly or not.

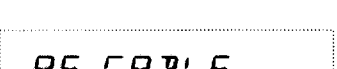
Procedure	Examples of display on the LCD
1. Press MENU .	
"MODE" blinks in the channel field of the LCD.	
2. Turn Jog Dial until "CHECK" appears.	
"CHECK" blinks in the channel field of the LCD.	
3. Press ENT .	
Self Diagnosis function starts.	
4. After completion, the result of the self diagnosis is displayed.	
<ul style="list-style-type: none"> • No fault 	
<ul style="list-style-type: none"> • Fault of Serial data line (Control unit – ATU) 	
<ul style="list-style-type: none"> • Fault of Serial data line (Control unit – DSP unit) 	
<ul style="list-style-type: none"> • Fault of CMN-1960 TRX unit 	
<ul style="list-style-type: none"> • Fault of CAH-1960 PA unit 	
<ul style="list-style-type: none"> • Fault of ATU or Antenna 	
<ul style="list-style-type: none"> • Fault of RF cable (PA unit – ATU) 	
5. Press CLR .	
The JSB-196GM exits the self diagnosis mode.	

Note

Shortcut key is available for the Self Diagnosis function as explained in "5.3.13 List of shortcut keys".

6. 2. 2 Firmware-Version Display

With this function, you can check the version of respective firmware installed in Control unit CDJ-1960, DSP and ATU NFC-196. Use this version number when you call our service center or agents.

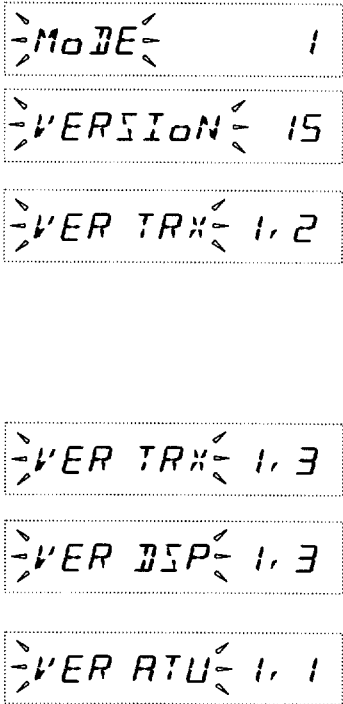
Procedure	Examples of display on the LCD
<ol style="list-style-type: none">1. Press MENU . "MODE" blinks in the channel field of the LCD.2. Turn Jog Dial until "VERSION" appears. "VERSION" blinks in the channel field of the LCD.3. Press ENT . The firmware-version number is displayed.4. Turn Jog Dial. Firmware-version numbers are displayed in the following order:<ul style="list-style-type: none">• CDJ-1960 Control UNIT• DSP• NFC-196 ATU5. Press CLR . The JSB-196GM exits the firmware-version display mode.	 <p>The LCD display examples are as follows:</p> <ul style="list-style-type: none">MODE 1VERSION 15VER TRX 1.2VER TRX 1.3VER DSP 1.3VER ATU 1.1

Note

Shortcut key is available for the firmware-version display mode as explained in "5.3.13 List of shortcut keys".

6.3 Troubleshooting

Each rectangle indicates process.

Each hexagon indicates decision.

(1) No receiving sound

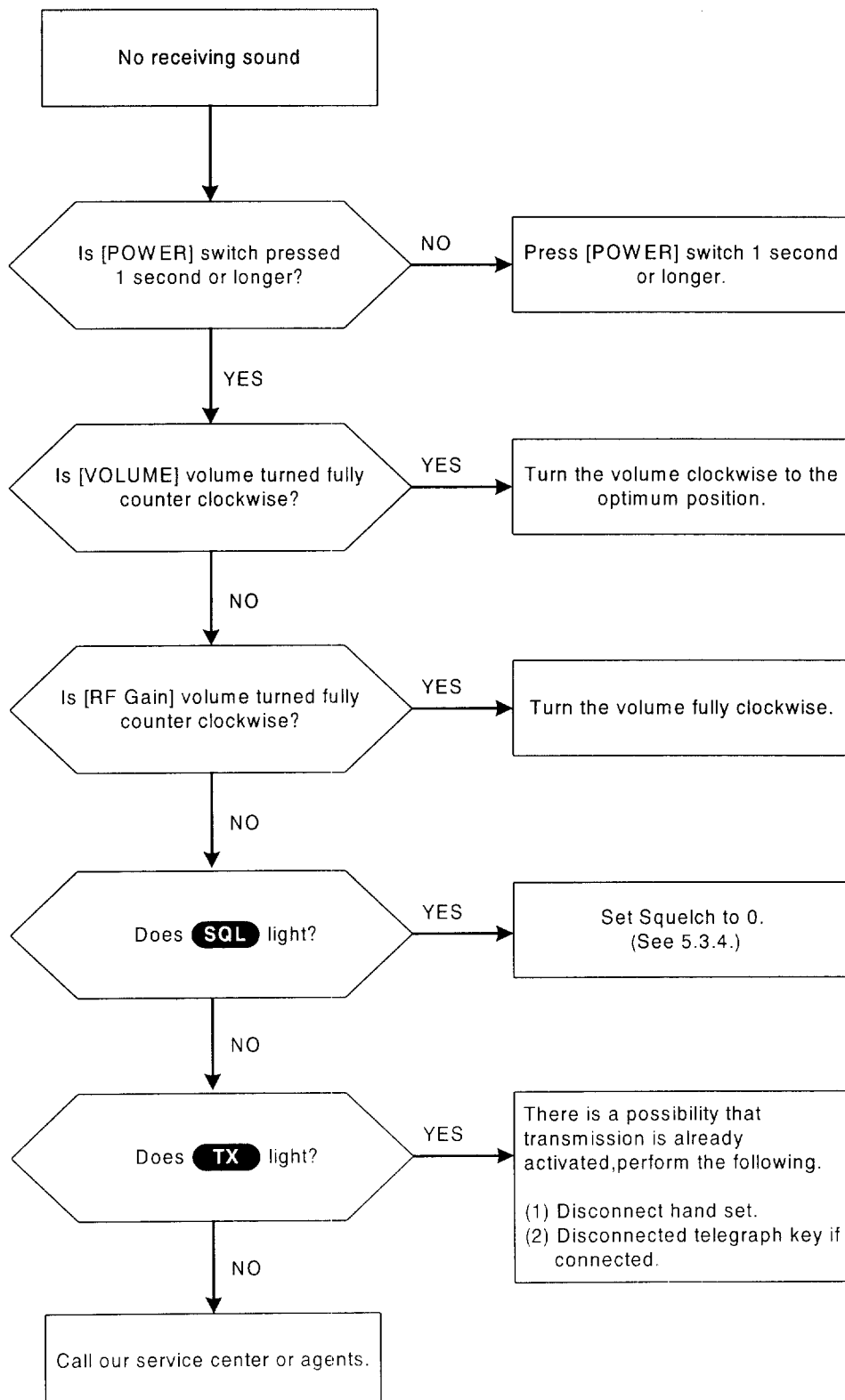

(2) No display on the LCD

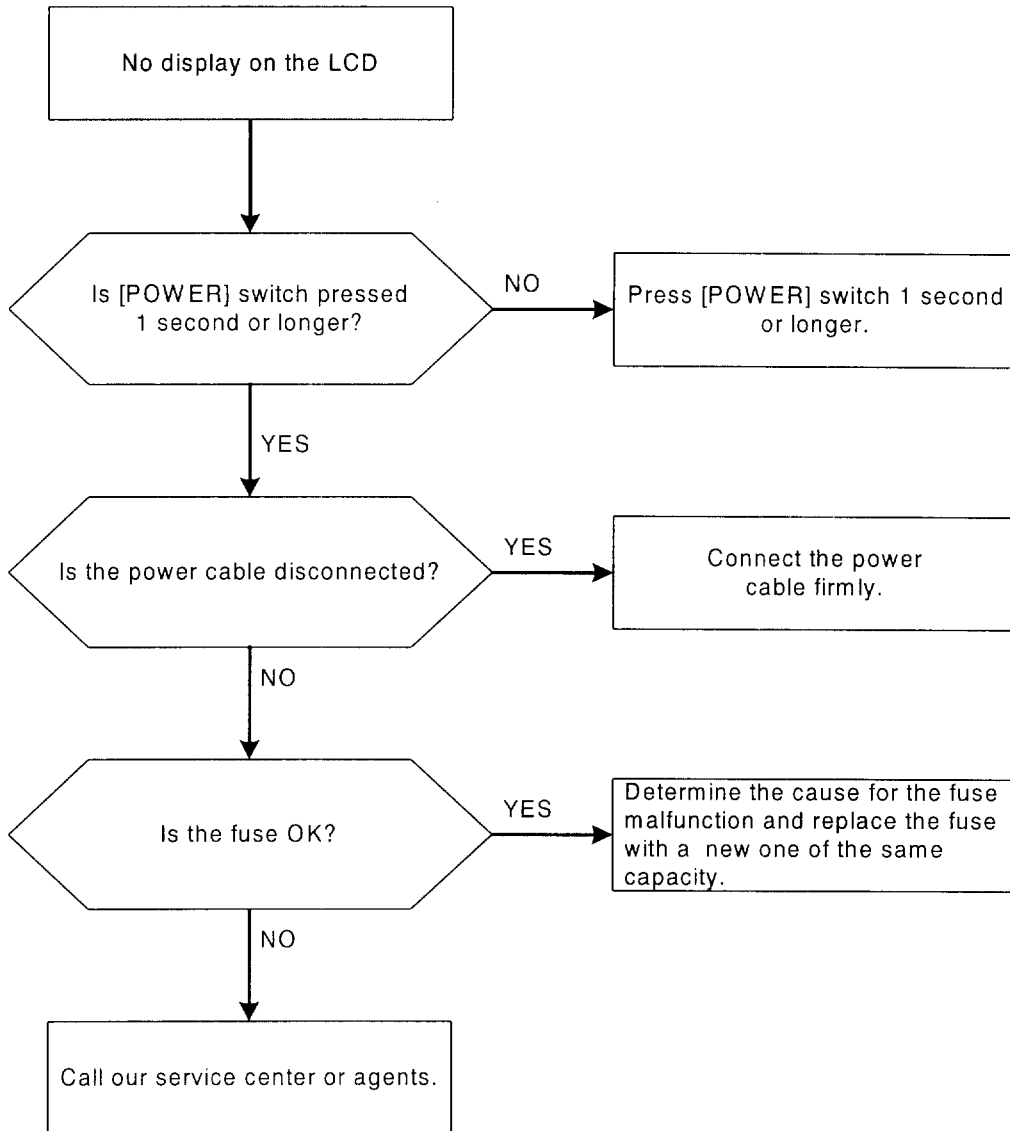

7. AFTER-SALES SERVICE

Before returning repair

If what appears to be a defect is detected, refer to “6.3 Troubleshooting” to check if the equipment is actually defective before requesting repair.

If the defect persists, immediately stop operation and call our service center or agents.

- During the warranty period, we or our agencies (*1) will repair the malfunction without any fee, according to the specified procedure.
- After the warranty expires, we will repair the malfunction for a fee, if repair is possible.
- Item for notification
Product name, type, manufactured data, serial number,
information about the malfunction (the more detailed, the better),
your company or organization name, address and phone number.

Periodical maintenance recommended

Performance of this equipment may degrade over time because parts wear out, although degradation depends on how this unit has been maintained.

We recommend periodic professional maintenance checks in addition to daily maintenance.

Call our service center or agents for periodic professional maintenance (This maintenance requires a service charge).

Call our office or the nearest agency for detailed information about after-sales service.

(*1) Refer to the inside of the back cover for contact numbers.

(3) Receiver

Sensitivity:	J3E	6.3 uV or better (1.6 to 4MHz) 3.5 uV or better (4 to 27.5MHz)
	F1B(DSC/TLX)	1.8 uV or better (1.6 to 4MHz) 1.0 uV or better (4 to 27.5MHz)
Receiving system:	Triple superheterodyne	
Intermediate frequencies:	70.455MHz, 455kHz, 20.217kHz	
Selectivity:	J3E	6 dB bandwidth 2.4 to 3kHz, 66 dB bandwidth Within ± 2.1 kHz
	F1B(DSC/TLX)	6 dB bandwidth 270 to 300Hz, 60 dB bandwidth Within ± 550 Hz
Spurious response:	60 dB or better	
Clarifier range:	± 200 Hz (1Hz steps)	
AF output:	5.0W max. 1W rated	

8.2 NFC-196 Antenna Tuner

Frequency range:	1.6 to 30MHz
Power capability:	200 W
SWR after tuning:	2:1
Tuning method:	Automatic tuning and preset tuning
Tuning time:	Automatic tuning: typical 3sec Preset tuning: typical 0.5sec
Operating temperature:	-30 to +60 °C
Power requirement:	10.2V DC to 16.2V DC, negative-grounded 1.5A max
Dimensions and mass:	230 mm(W) \times 380 mm(H) \times 90 mm(D), Approx. 3.3 kg

9. APPENDIX

9.1 Allocation of ITU Channels

Channel			Channel			Channel			Channel		
Designator	Ship Tx	Ship Rx	Designator	Ship Tx	Ship Rx	Designator	Ship Tx	Ship Rx	Designator	Ship Tx	Ship Rx
(Telephone)			820	8252.0	8776.0	1246	12365.0		1661	16540.0	
401	4065.0	4357.0	821	8255.0	8779.0				1662	16543.0	
402	4068.0	4360.0	822	8258.0	8782.0	1601	16360.0	17242.0	1663	16546.0	
403	4071.0	4363.0	823	8261.0	8785.0	1602	16363.0	17245.0			
404	4074.0	4366.0	824	8264.0	8788.0	1603	16366.0	17248.0	1801	18780.0	19755.0
405	4077.0	4369.0	825	8267.0	8791.0	1604	16369.0	17251.0	1802	18783.0	19758.0
406	4080.0	4372.0	826	8270.0	8794.0	1605	16372.0	17254.0	1803	18786.0	19761.0
407	4083.0	4375.0	827	8273.0	8797.0	1606	16375.0	17257.0	1804	18789.0	19764.0
408	4086.0	4378.0	828	8276.0	8800.0	1607	16378.0	17260.0	1805	18792.0	19767.0
409	4089.0	4381.0	829	8279.0	8803.0	1608	16381.0	17263.0	1806	18795.0	19770.0
410	4092.0	4384.0	830	8282.0	8806.0	1609	16384.0	17266.0	1807	18798.0	19773.0
411	4095.0	4387.0	831	8285.0	8809.0	1610	16387.0	17269.0	1808	18801.0	19776.0
412	4098.0	4390.0	832	8288.0	8812.0	1611	16390.0	17272.0	1809	18804.0	19779.0
413	4101.0	4393.0	833	8291.0	8291.0	1612	16393.0	17275.0	1810	18807.0	19782.0
414	4104.0	4396.0	834	8294.0		1613	16396.0	17278.0	1811	18810.0	19785.0
415	4107.0	4399.0	835	8297.0		1614	16399.0	17281.0	1812	18813.0	19788.0
416	4110.0	4402.0				1615	16402.0	17284.0	1813	18816.0	19791.0
417	4113.0	4405.0	1201	12230.0	13077.0	1616	16405.0	17287.0	1814	18819.0	19794.0
418	4116.0	4408.0	1202	12233.0	13080.0	1617	16408.0	17290.0	1815	18822.0	19797.0
419	4119.0	4411.0	1203	12236.0	13083.0	1618	16411.0	17293.0	1816	18825.0	
420	4122.0	4414.0	1204	12239.0	13086.0	1619	16414.0	17296.0	1817	18828.0	
421	4125.0	4417.0	1205	12242.0	13089.0	1620	16417.0	17299.0	1818	18831.0	
422	4128.0	4420.0	1206	12245.0	13092.0	1621	16420.0	17302.0	1819	18834.0	
423	4131.0	4423.0	1207	12248.0	13095.0	1622	16423.0	17305.0	1820	18837.0	
424	4134.0	4426.0	1208	12251.0	13098.0	1623	16426.0	17308.0	1821	18840.0	
425	4137.0	4429.0	1209	12254.0	13101.0	1624	16429.0	17311.0	1822	18843.0	
426	4140.0	4432.0	1210	12257.0	13104.0	1625	16432.0	17314.0			
427	4143.0	4435.0	1211	12260.0	13107.0	1626	16435.0	17317.0	2201	22000.0	22696.0
428	4146.0		1212	12263.0	13110.0	1627	16438.0	17320.0	2202	22003.0	22699.0
429	4149.0		1213	12266.0	13113.0	1628	16441.0	17323.0	2203	22006.0	22702.0
			1214	12269.0	13116.0	1629	16444.0	17326.0	2204	22009.0	22705.0
601	6200.0	6501.0	1215	12272.0	13119.0	1630	16447.0	17329.0	2205	22012.0	22708.0
602	6203.0	6504.0	1216	12275.0	13122.0	1631	16450.0	17332.0	2206	22015.0	22711.0
603	6206.0	6507.0	1217	12278.0	13125.0	1632	16453.0	17335.0	2207	22018.0	22714.0
604	6209.0	6510.0	1218	12281.0	13128.0	1633	16456.0	17338.0	2208	22021.0	22717.0
605	6212.0	6513.0	1219	12284.0	13131.0	1634	16459.0	17341.0	2209	22024.0	22720.0
606	6215.0	6516.0	1220	12287.0	13134.0	1635	16462.0	17344.0	2210	22027.0	22723.0
607	6218.0	6519.0	1221	12290.0	13137.0	1636	16465.0	17347.0	2211	22030.0	22726.0
608	6221.0	6522.0	1222	12293.0	13140.0	1637	16468.0	17350.0	2212	22033.0	22729.0
609	6224.0		1223	12296.0	13143.0	1638	16471.0	17353.0	2213	22036.0	22732.0
610	6227.0		1224	12299.0	13146.0	1639	16474.0	17356.0	2214	22039.0	22735.0
611	6230.0		1225	12302.0	13149.0	1640	16477.0	17359.0	2215	22042.0	22738.0
			1226	12305.0	13152.0	1641	16480.0	17362.0	2216	22045.0	22741.0
801	8195.0	8719.0	1227	12308.0	13155.0	1642	16483.0	17365.0	2217	22048.0	22744.0
802	8198.0	8722.0	1228	12311.0	13158.0	1643	16486.0	17368.0	2218	22051.0	22747.0
803	8201.0	8725.0	1229	12314.0	13161.0	1644	16489.0	17371.0	2219	22054.0	22750.0
804	8204.0	8728.0	1230	12317.0	13164.0	1645	16492.0	17374.0	2220	22057.0	22753.0
805	8207.0	8731.0	1231	12320.0	13167.0	1646	16495.0	17377.0	2221	22060.0	22756.0
806	8210.0	8734.0	1232	12323.0	13170.0	1647	16498.0	17380.0	2222	22063.0	22759.0
807	8213.0	8737.0	1233	12326.0	13173.0	1648	16501.0	17383.0	2223	22066.0	22762.0
808	8216.0	8740.0	1234	12329.0	13176.0	1649	16504.0	17386.0	2224	22069.0	22765.0
809	8219.0	8743.0	1235	12332.0	13179.0	1650	16507.0	17389.0	2225	22072.0	22768.0
810	8222.0	8746.0	1236	12335.0	13182.0	1651	16510.0	17392.0	2226	22075.0	22771.0
811	8225.0	8749.0	1237	12338.0	13185.0	1652	16513.0	17395.0	2227	22078.0	22774.0
812	8228.0	8752.0	1238	12341.0	13188.0	1653	16516.0	17398.0	2228	22081.0	22777.0
813	8231.0	8755.0	1239	12344.0	13191.0	1654	16519.0	17401.0	2229	22084.0	22780.0
814	8234.0	8758.0	1240	12347.0	13194.0	1655	16522.0	17404.0	2230	22087.0	22783.0
815	8237.0	8761.0	1241	12350.0	13197.0	1656	16525.0	17407.0	2231	22090.0	22786.0
816	8240.0	8764.0	1242	12353.0		1657	16528.0		2232	22093.0	22789.0
817	8243.0	8767.0	1243	12356.0		1658	16531.0		2233	22096.0	22792.0
818	8246.0	8770.0	1244	12359.0		1659	16534.0		2234	22099.0	22795.0
819	8249.0	8773.0	1245	12362.0		1660	16537.0		2235	22102.0	22798.0

Channel			Channel			Channel			Channel		
Designator	Ship Tx	Ship RX	Designator	Ship Tx	Ship RX	Designator	Ship Tx	Ship RX	Designator	Ship Tx	Ship RX
(Telephone)			417	4190.0		637	6298.0		857	8365.0	
2236	22105.0	22801.0	418	4190.5		638	6298.5		858	8365.5	
2237	22108.0	22804.0	419	4191.0		639	6299.0		859	8371.0	
2238	22111.0	22807.0	420	4191.5		640	6299.5		860	8371.5	
2239	22114.0	22810.0	421	4192.0		641	6300.0		861	8372.0	
2240	22117.0	22813.0	422	4192.5					862	8372.5	
2241	22120.0	22816.0	423	4193.0		801	8366.0		863	8373.0	
2242	22123.0	22819.0	424	4193.5		802	8366.5		864	8373.5	
2243	22126.0	22822.0	425	4194.0		803	8368.0		865	8374.0	
2244	22129.0	22825.0	426	4194.5		804	8369.0		866	8374.5	
2245	22132.0	22828.0	427	4195.0		805	8367.0		867	8375.0	
2246	22135.0	22831.0	428	4195.5		806	8367.5		868	8375.5	
2247	22138.0	22834.0	429	4196.0		807	8368.5		869	8376.0	
2248	22141.0	22837.0	430	4196.5		808	8369.5				
2249	22144.0	22840.0	431	4197.0		809	8370.0		1201	12550.0	
2250	22147.0	22843.0	432	4197.5		810	8370.5		1202	12550.5	
2251	22150.0	22846.0	433	4198.0		811	8342.0		1203	12552.0	
2252	22153.0	22849.0	434	4198.5		812	8342.5		1204	12553.5	
2253	22156.0	22852.0	435	4199.0		813	8343.0		1205	12551.0	
2254	22159.0		436	4199.5		814	8343.5		1206	12551.5	
2255	22162.0		437	4200.0		815	8344.0		1207	12552.5	
2256	22165.0		438	4200.5		816	8344.5		1208	12553.0	
2257	22168.0		439	4201.0		817	8345.0		1209	12554.0	
2258	22171.0		440	4201.5		818	8345.5		1210	12554.5	
2259	22174.0		441	4202.0		819	8346.0		1211	12422.0	
2260	22177.0					820	8346.5		1212	12422.5	
			601	6277.0		821	8347.0		1213	12423.0	
2501	25070.0	26145.0	602	6277.5		822	8347.5		1214	12423.5	
2502	25073.0	26148.0	603	6276.0		823	8348.0		1215	12424.0	
2503	25076.0	26151.0	604	6276.5		824	8348.5		1216	12424.5	
2504	25079.0	26154.0	605	6278.0		825	8349.0		1217	12425.0	
2505	25082.0	26157.0	606	6278.5		826	8349.5		1218	12425.5	
2506	25085.0	26160.0	607	6279.0		827	8350.0		1219	12426.0	
2507	25088.0	26163.0	608	6279.5		828	8350.5		1220	12426.5	
2508	25091.0	26166.0	609	6280.0		829	8351.0		1221	12427.0	
2509	25094.0	26169.0	610	6280.5		830	8351.5		1222	12427.5	
2510	25097.0	26172.0	611	6285.0		831	8352.0		1223	12428.0	
2511	25100.0		612	6285.5		832	8352.5		1224	12428.5	
2512	25103.0		613	6286.0		833	8353.0		1225	12429.0	
2513	25106.0		614	6286.5		834	8353.5		1226	12429.5	
2514	25109.0		615	6287.0		835	8354.0		1227	12430.0	
2515	25112.0		616	6287.5		836	8354.5		1228	12430.5	
2516	25115.0		617	6288.0		837	8355.0		1229	12431.0	
2517	25118.0		618	6288.5		838	8355.5		1230	12431.5	
			619	6289.0		839	8356.0		1231	12432.0	
(Morse)			620	6289.5		840	8356.5		1232	12432.5	
401	4182.0		621	6290.0		841	8357.0		1233	12433.0	
402	4182.5		622	6290.5		842	8357.5		1234	12433.5	
403	4184.0		623	6291.0		843	8358.0		1235	12434.0	
404	4184.5		624	6291.5		844	8358.5		1236	12434.5	
405	4183.0		625	6292.0		845	8359.0		1237	12435.0	
406	4183.5		626	6292.5		846	8359.5		1238	12435.5	
407	4185.0		627	6293.0		847	8360.0		1239	12436.0	
408	4185.5		628	6293.5		848	8360.5		1240	12436.5	
409	4186.0		629	6294.0		849	8361.0		1241	12437.0	
410	4186.5		630	6294.5		850	8361.5		1242	12437.5	
411	4187.0		631	6295.0		851	8362.0		1243	12438.0	
412	4187.5		632	6295.5		852	8362.5		1244	12438.5	
413	4188.0		633	6296.0		853	8363.0		1245	12439.0	
414	4188.5		634	6296.5		854	8363.5		1246	12439.5	
415	4189.0		635	6297.0		855	8364.0		1247	12440.0	
416	4189.5		636	6297.5		856	8364.5		1248	12440.5	

Channel Designator	Ship Tx	Ship Rx	Channel Designator	Ship Tx	Ship Rx	Channel Designator	Ship Tx	Ship Rx	Channel Designator	Ship Tx	Ship Rx
(Morse)			12110	12471.5		1651	16639.0		16113	16670.0	
1249	12441.0		12111	12472.0		1652	16639.5		16114	16670.5	
1250	12441.5		12112	12472.5		1653	16640.0		16115	16671.0	
1251	12442.0		12113	12473.0		1654	16640.5		16116	16671.5	
1252	12442.5		12114	12473.5		1655	16641.0		16117	16672.0	
1253	12443.0		12115	12474.0		1656	16641.5		16118	16672.5	
1254	12443.5		12116	12474.5		1657	16642.0		16119	16673.0	
1255	12444.0		12117	12475.0		1658	16642.5		16120	16673.5	
1256	12444.5		12118	12475.5		1659	16643.0		16121	16674.0	
1257	12445.0		12119	12476.0		1660	16643.5		16122	16674.5	
1258	12445.5		12120	12476.5		1661	16644.0		16123	16675.0	
1259	12446.0					1662	16644.5		16124	16675.5	
1260	12446.5		1601	16734.0		1663	16645.0		16125	16676.0	
1261	12447.0		1602	16734.5		1664	16645.5		16126	16676.5	
1262	12447.5		1603	16736.0		1665	16646.0		16127	16677.0	
1263	12448.0		1604	16738.0		1666	16646.5		16128	16677.5	
1264	12448.5		1605	16735.0		1667	16647.0		16129	16678.0	
1265	12449.0		1606	16735.5		1668	16647.5		16130	16678.5	
1266	12449.5		1607	16736.5		1669	16648.0		16131	16679.0	
1267	12450.0		1608	16737.0		1670	16648.5		16132	16679.5	
1268	12450.5		1609	16737.5		1671	16649.0		16133	16680.0	
1269	12451.0		1610	16738.5		1672	16649.5		16134	16680.5	
1270	12451.5		1611	16619.0		1673	16650.0		16135	16681.0	
1271	12452.0		1612	16619.5		1674	16650.5		16136	16681.5	
1272	12452.5		1613	16620.0		1675	16651.0		16137	16682.0	
1273	12453.0		1614	16620.5		1676	16651.5		16138	16682.5	
1274	12453.5		1615	16621.0		1677	16652.0		16139	16683.0	
1275	12454.0		1616	16621.5		1678	16652.5				
1276	12454.5		1617	16622.0		1679	16653.0		2201	22279.5	
1277	12455.0		1618	16622.5		1680	16653.5		2202	22280.0	
1278	12455.5		1619	16623.0		1681	16654.0		2203	22280.5	
1279	12456.0		1620	16623.5		1682	16654.5		2204	22281.0	
1280	12456.5		1621	16624.0		1683	16655.0		2205	22281.5	
1281	12457.0		1622	16624.5		1684	16655.5		2206	22282.0	
1282	12457.5		1623	16625.0		1685	16656.0		2207	22282.5	
1283	12458.0		1624	16625.5		1686	16656.5		2208	22283.0	
1284	12458.5		1625	16626.0		1687	16657.0		2209	22283.5	
1285	12459.0		1626	16626.5		1688	16657.5		2210	22284.0	
1286	12459.5		1627	16627.0		1689	16658.0		2211	22242.0	
1287	12460.0		1628	16627.5		1690	16658.5		2212	22242.5	
1288	12460.5		1629	16628.0		1691	16659.0		2213	22243.0	
1289	12461.0		1630	16628.5		1692	16659.5		2214	22243.5	
1290	12461.5		1631	16629.0		1693	16660.0		2215	22244.0	
1291	12462.0		1632	16629.5		1694	16660.5		2216	22244.5	
1292	12462.5		1633	16630.0		1695	16661.0		2217	22245.0	
1293	12463.0		1634	16630.5		1696	16661.5		2218	22245.5	
1294	12463.5		1635	16631.0		1697	16662.0		2219	22246.0	
1295	12464.0		1636	16631.5		1698	16662.5		2220	22246.5	
1296	12464.5		1637	16632.0		1699	16663.0		2221	22247.0	
1297	12465.0		1638	16632.5		16100	16663.5		2222	22247.5	
1298	12465.5		1639	16633.0		16101	16664.0		2223	22248.0	
1299	12466.0		1640	16633.5		16102	16664.5		2224	22248.5	
12100	12466.5		1641	16634.0		16103	16665.0		2225	22249.0	
12101	12467.0		1642	16634.5		16104	16665.5		2226	22249.5	
12102	12467.5		1643	16635.0		16105	16666.0		2227	22250.0	
12103	12468.0		1644	16635.5		16106	16666.5		2228	22250.5	
12104	12468.5		1645	16636.0		16107	16667.0		2229	22251.0	
12105	12469.0		1646	16636.5		16108	16667.5		2230	22251.5	
12106	12469.5		1647	16637.0		16109	16668.0		2231	22252.0	
12107	12470.0		1648	16637.5		16110	16668.5		2232	22252.5	
12108	12470.5		1649	16638.0		16111	16669.0		2233	22253.0	
12109	12471.0		1650	16638.5		16112	16669.5		2234	22253.5	

Channel Designator	Ship Tx	Ship Rx	Channel Designator	Ship Tx	Ship Rx	Channel Designator	Ship Tx	Ship Rx	Channel Designator	Ship Tx	Ship Rx
(Morse)			2510	25164.0		616	6270.5	6321.5	820	8386.0	8426.0
2235	22254.0		2511	25164.5		617	6271.0	6322.0	821	8386.5	8426.5
2236	22254.5		2512	25165.0		618	6271.5	6322.5	822	8387.0	8427.0
2237	22255.0		2513	25165.5		619	6272.0	6323.0	823	8387.5	8427.5
2238	22255.5		2514	25166.0		620	6272.5	6323.5	824	8388.0	8428.0
2239	22256.0		2515	25166.5		621	6273.0	6324.0	825	8388.5	8428.5
2240	22256.5		2516	25167.0		622	6273.5	6324.5	826	8389.0	8429.0
2241	22257.0		2517	25167.5		623	6274.0	6325.0	827	8389.5	8429.5
2242	22257.5		2518	25168.0		624	6274.5	6325.5	828	8390.0	8430.0
2243	22258.0		2519	25168.5		625	6275.0	6326.0	829	8390.5	8430.5
2244	22258.5		2520	25169.0		626	6275.5	6326.5	830	8391.0	8431.0
2245	22259.0		2521	25169.5		627	6281.0	6327.0	831	8391.5	8431.5
2246	22259.5		2522	25170.0		628	6281.5	6327.5	832	8392.0	8432.0
2247	22260.0		2523	25170.5		629	6282.0	6328.0	833	8392.5	8432.5
2248	22260.5		2524	25171.0		630	6282.5	6328.5	834	8393.0	8433.0
2249	22261.0					631	6283.0	6329.0	835	8393.5	8433.5
2250	22261.5		(Telex)			632	6283.5	6329.5	836	8394.0	8434.0
2251	22262.0		401	4172.5	4210.5	633	6284.0	6330.0	837	8394.5	8434.5
2252	22262.5		402	4173.0	4211.0	634	6284.5	6330.5	838	8395.0	8435.0
2253	22263.0		403	4173.5	4211.5	635	6300.5		839	8395.5	8435.5
2254	22263.5		404	4174.0	4212.0	636	6301.0		840	8396.0	8436.0
2255	22264.0		405	4174.5	4212.5	637	6301.5		841	8396.5	
2256	22264.5		406	4175.0	4213.0	638	6302.0		842	8397.0	
2257	22265.0		407	4175.5	4213.5	639	6302.5		843	8397.5	
2258	22265.5		408	4176.0	4214.0	640	6303.0		844	8398.0	
2259	22266.0		409	4176.5	4214.5	641	6303.5		845	8398.5	
2260	22266.5		410	4177.0	4215.0	642	6304.0		846	8399.0	
2261	22267.0		411	4177.5	4177.5	643	6304.5		847	8399.5	
2262	22267.5		412	4178.0	4215.5	644	6305.0		848	8400.0	
2263	22268.0		413	4178.5	4216.0	645	6305.5		849	8400.5	
2264	22268.5		414	4179.0	4216.5	646	6306.0		850	8401.0	
2265	22269.0		415	4179.5	4217.0	647	6306.5		851	8401.5	
2266	22269.5		416	4180.0	4217.5	648	6307.0		852	8402.0	
2267	22270.0		417	4180.5	4218.0	649	6307.5		853	8402.5	
2268	22270.5		418	4181.0	4218.5	650	6308.0		854	8403.0	
2269	22271.0		419	4181.5	4219.0	651	6308.5		855	8403.5	
2270	22271.5		420	4202.5		652	6309.0		856	8404.0	
2271	22272.0		421	4203.0		653	6309.5		857	8404.5	
2272	22272.5		422	4203.5		654	6310.0		858	8405.0	
2273	22273.0		423	4204.0		655	6310.5		859	8405.5	
2274	22273.5		424	4204.5		656	6311.0		860	8406.0	
2275	22274.0		425	4205.0		657	6311.5		861	8406.5	
2276	22274.5		426	4205.5					862	8407.0	
2277	22275.0		427	4206.0		801	8376.5	8376.5	863	8407.5	
2278	22275.5		428	4206.5		802	8377.0	8417.0	864	8408.0	
2279	22276.0		429	4207.0		803	8377.5	8417.5	865	8408.5	
2280	22276.5					804	8378.0	8418.0	866	8409.0	
2281	22277.0		601	6263.0	6314.5	805	8378.5	8418.5	867	8409.5	
2282	22277.5		602	6263.5	6315.0	806	8379.0	8419.0	868	8410.0	
2283	22278.0		603	6264.0	6315.5	807	8379.5	8419.5	869	8410.5	
2284	22278.5		604	6264.5	6316.0	808	8380.0	8420.0	870	8411.0	
2285	22279.0		605	6265.0	6316.5	809	8380.5	8420.5	871	8411.5	
			606	6265.5	6317.0	810	8381.0	8421.0	872	8412.0	
2501	25171.5		607	6266.0	6317.5	811	8381.5	8421.5	873	8412.5	
2502	25172.0		608	6266.5	6318.0	812	8382.0	8422.0	874	8413.0	
2503	25171.5		609	6267.0	6318.5	813	8382.5	8422.5	875	8413.5	
2504	25172.5		610	6267.5	6319.0	814	8383.0	8423.0	876	8414.0	
2505	25161.5		611	6268.0	6268.0	815	8383.5	8423.5			
2506	25162.0		612	6268.5	6319.5	816	8384.0	8424.0	1201	12477.0	12579.5
2507	25162.5		613	6269.0	6320.0	817	8384.5	8424.5	1202	12477.5	12580.0
2508	25163.0		614	6269.5	6320.5	818	8385.0	8425.0	1203	12478.0	12580.5
2509	25163.5		615	6270.0	6321.0	819	8385.5	8425.5	1204	12478.5	12581.0

Channel			Channel			Channel			Channel		
Designator	Ship Tx	Ship Rx	Designator	Ship Tx	Ship Rx	Designator	Ship Tx	Ship Rx	Designator	Ship Tx	Ship Rx
(Telex)			1266	12509.5	12612.0	12128	12540.5	12642.5	12190	12576.5	
1205	12479.0	12581.5	1267	12510.0	12612.5	12129	12541.0	12643.0			
1206	12479.5	12582.0	1268	12510.5	12613.0	12130	12541.5	12643.5	1601	16683.5	16807.0
1207	12480.0	12582.5	1269	12511.0	12613.5	12131	12542.0	12644.0	1602	16684.0	16807.5
1208	12480.5	12583.0	1270	12511.5	12614.0	12132	12542.5	12644.5	1603	16684.5	16808.0
1209	12481.0	12583.5	1271	12512.0	12614.5	12133	12543.0	12645.0	1604	16685.0	16808.5
1210	12481.5	12584.0	1272	12512.5	12615.0	12134	12543.5	12645.5	1605	16685.5	16809.0
1211	12482.0	12584.5	1273	12513.0	12615.5	12135	12544.0	12646.0	1606	16686.0	16809.5
1212	12482.5	12585.0	1274	12513.5	12616.0	12136	12544.5	12646.5	1607	16686.5	16810.0
1213	12483.0	12585.5	1275	12514.0	12616.5	12137	12545.0	12647.0	1608	16687.0	16810.5
1214	12483.5	12586.0	1276	12514.5	12617.0	12138	12545.5	12647.5	1609	16687.5	16811.0
1215	12484.0	12586.5	1277	12515.0	12617.5	12139	12546.0	12648.0	1610	16688.0	16811.5
1216	12484.5	12587.0	1278	12515.5	12618.0	12140	12546.5	12648.5	1611	16688.5	16812.0
1217	12485.0	12587.5	1279	12516.0	12618.5	12141	12547.0	12649.0	1612	16689.0	16812.5
1218	12485.5	12588.0	1280	12516.5	12619.0	12142	12547.5	12649.5	1613	16689.5	16813.0
1219	12486.0	12588.5	1281	12517.0	12619.5	12143	12548.0	12650.0	1614	16690.0	16813.5
1220	12486.5	12589.0	1282	12517.5	12620.0	12144	12548.5	12650.5	1615	16690.5	16814.0
1221	12487.0	12589.5	1283	12518.0	12620.5	12145	12549.0	12651.0	1616	16691.0	16814.5
1222	12487.5	12590.0	1284	12518.5	12621.0	12146	12549.5	12651.5	1617	16691.5	16815.0
1223	12488.0	12590.5	1285	12519.0	12621.5	12147	12550.0	12652.0	1618	16692.0	16815.5
1224	12488.5	12591.0	1286	12519.5	12622.0	12148	12550.5	12652.5	1619	16692.5	16816.0
1225	12489.0	12591.5	1287	12520.0	12622.5	12149	12551.0	12653.0	1620	16693.0	16816.5
1226	12489.5	12592.0	1288	12520.5	12623.0	12150	12551.5	12653.5	1621	16693.5	16817.0
1227	12490.0	12592.5	1289	12521.0	12623.5	12151	12552.0	12654.0	1622	16694.0	16817.5
1228	12490.5	12593.0	1290	12521.5	12624.0	12152	12552.5	12654.5	1623	16694.5	16818.0
1229	12491.0	12593.5	1291	12522.0	12624.5	12153	12553.0	12655.0	1624	16695.0	16818.5
1230	12491.5	12594.0	1292	12522.5	12625.0	12154	12553.5	12655.5	1625	16695.5	16819.0
1231	12492.0	12594.5	1293	12523.0	12625.5	12155	12554.0	12656.0	1626	16696.0	16819.5
1232	12492.5	12595.0	1294	12523.5	12626.0	12156	12554.5	12656.5	1627	16696.5	16820.0
1233	12493.0	12595.5	1295	12524.0	12626.5	12157	12560.0		1628	16697.0	16820.5
1234	12493.5	12596.0	1296	12524.5	12627.0	12158	12560.5		1629	16697.5	16821.0
1235	12494.0	12596.5	1297	12525.0	12627.5	12159	12561.0		1630	16698.0	16821.5
1236	12494.5	12597.0	1298	12525.5	12628.0	12160	12561.5		1631	16698.5	16822.0
1237	12495.0	12597.5	1299	12526.0	12628.5	12161	12562.0		1632	16699.0	16822.5
1238	12495.5	12598.0	12100	12526.5	12629.0	12162	12562.5		1633	16699.5	16823.0
1239	12496.0	12598.5	12101	12527.0	12629.5	12163	12563.0		1634	16700.0	16823.5
1240	12496.5	12599.0	12102	12527.5	12630.0	12164	12563.5		1635	16700.5	16824.0
1241	12497.0	12599.5	12103	12528.0	12630.5	12165	12564.0		1636	16701.0	16824.5
1242	12497.5	12600.0	12104	12528.5	12631.0	12166	12564.5		1637	16701.5	16825.0
1243	12498.0	12600.5	12105	12529.0	12631.5	12167	12565.0		1638	16702.0	16825.5
1244	12498.5	12601.0	12106	12529.5	12632.0	12168	12565.5		1639	16702.5	16826.0
1245	12499.0	12601.5	12107	12530.0	12632.5	12169	12566.0		1640	16703.0	16826.5
1246	12499.5	12602.0	12108	12530.5	12633.0	12170	12566.5		1641	16703.5	16827.0
1247	12500.0	12602.5	12109	12531.0	12633.5	12171	12567.0		1642	16704.0	16827.5
1248	12500.5	12603.0	12110	12531.5	12634.0	12172	12567.5		1643	16704.5	16828.0
1249	12501.0	12603.5	12111	12532.0	12634.5	12173	12568.0		1644	16705.0	16828.5
1250	12501.5	12604.0	12112	12532.5	12635.0	12174	12568.5		1645	16705.5	16829.0
1251	12502.0	12604.5	12113	12533.0	12635.5	12175	12569.0		1646	16706.0	16829.5
1252	12502.5	12605.0	12114	12533.5	12636.0	12176	12569.5		1647	16706.5	16830.0
1253	12503.0	12605.5	12115	12534.0	12636.5	12177	12570.0		1648	16707.0	16830.5
1254	12503.5	12606.0	12116	12534.5	12637.0	12178	12570.5		1649	16707.5	16831.0
1255	12504.0	12606.5	12117	12535.0	12637.5	12179	12571.0		1650	16708.0	16831.5
1256	12504.5	12607.0	12118	12535.5	12638.0	12180	12571.5		1651	16708.5	16832.0
1257	12505.0	12607.5	12119	12536.0	12638.5	12181	12572.0		1652	16709.0	16832.5
1258	12505.5	12608.0	12120	12536.5	12639.0	12182	12572.5		1653	16709.5	16833.0
1259	12506.0	12608.5	12121	12537.0	12640.0	12183	12573.0		1654	16710.0	16833.5
1260	12506.5	12609.0	12122	12537.5	12640.5	12184	12573.5		1655	16710.5	16834.0
1261	12507.0	12609.5	12123	12538.0	12641.0	12185	12574.0		1656	16711.0	16834.5
1262	12507.5	12610.0	12124	12538.5	12641.5	12186	12574.5		1657	16711.5	16835.0
1263	12508.0	12610.5	12125	12539.0	12642.0	12187	12575.0		1658	16712.0	16835.5
1264	12508.5	12611.0	12126	12539.5	12642.5	12188	12575.5		1659	16712.5	16836.0
1265	12509.0	12611.5	12127	12540.0	12643.0	12189	12576.0		1660	16713.0	16836.5

Channel Designator	Ship Tx	Ship Rx	Channel Designator	Ship Tx	Ship Rx	Channel Designator	Ship Tx	Ship Rx	Channel Designator	Ship Tx	Ship Rx
(Telex)			16122	16749.0	16867.0	16184	16780.0	16898.0	1813	18876.5	19687.0
1661	16713.5	16836.5	16123	16749.5	16867.5	16185	16780.5	16898.5	1814	18877.0	19687.5
1662	16714.0	16837.0	16124	16750.0	16868.0	16186	16781.0	16899.0	1815	18877.5	19688.0
1663	16714.5	16837.5	16125	16750.5	16868.5	16187	16781.5	16899.5	1816	18878.0	19688.5
1664	16715.0	16838.0	16126	16751.0	16869.0	16188	16782.0	16900.0	1817	18878.5	19689.0
1665	16715.5	16838.5	16127	16751.5	16869.5	16189	16782.5	16900.5	1818	18879.0	19689.5
1666	16716.0	16839.0	16128	16752.0	16870.0	16190	16783.0	16901.0	1819	18879.5	19690.0
1667	16716.5	16839.5	16129	16752.5	16870.5	16191	16783.5	16901.5	1820	18880.0	19690.5
1668	16717.0	16840.0	16130	16753.0	16871.0	16192	16784.0	16902.0	1821	18880.5	19691.0
1669	16717.5	16840.5	16131	16753.5	16871.5	16193	16784.5	16902.5	1822	18881.0	19691.5
1670	16718.0	16841.0	16132	16754.0	16872.0	16194	16785.0		1823	18881.5	19692.0
1671	16718.5	16841.5	16133	16754.5	16872.5	16195	16785.5		1824	18882.0	19692.5
1672	16719.0	16842.0	16134	16755.0	16873.0	16196	16786.0		1825	18882.5	19693.0
1673	16719.5	16842.5	16135	16755.5	16873.5	16197	16786.5		1826	18883.0	19693.5
1674	16720.0	16843.0	16136	16756.0	16874.0	16198	16787.0		1827	18883.5	19694.0
1675	16720.5	16843.5	16137	16756.5	16874.5	16199	16787.5		1828	18884.0	19694.5
1676	16721.0	16844.0	16138	16757.0	16875.0	16200	16788.0		1829	18884.5	19695.0
1677	16721.5	16844.5	16139	16757.5	16875.5	16201	16788.5		1830	18885.0	19695.5
1678	16722.0	16845.0	16140	16758.0	16876.0	16202	16789.0		1831	18885.5	19696.0
1679	16722.5	16845.5	16141	16758.5	16876.5	16203	16789.5		1832	18886.0	19696.5
1680	16723.0	16846.0	16142	16759.0	16877.0	16204	16790.0		1833	18886.5	19697.0
1681	16723.5	16846.5	16143	16759.5	16877.5	16205	16790.5		1834	18887.0	19697.5
1682	16724.0	16847.0	16144	16760.0	16878.0	16206	16791.0		1835	18887.5	19698.0
1683	16724.5	16847.5	16145	16760.5	16878.5	16207	16791.5		1836	18888.0	19698.5
1684	16725.0	16848.0	16146	16761.0	16879.0	16208	16792.0		1837	18888.5	19699.0
1685	16725.5	16848.5	16147	16761.5	16879.5	16209	16792.5		1838	18889.0	19699.5
1686	16726.0	16849.0	16148	16762.0	16880.0	16210	16793.0		1839	18889.5	19700.0
1687	16726.5	16849.5	16149	16762.5	16880.5	16211	16793.5		1840	18890.0	19700.5
1688	16727.0	16850.0	16150	16763.0	16881.0	16212	16794.0		1841	18890.5	19701.0
1689	16727.5	16850.5	16151	16763.5	16881.5	16213	16794.5		1842	18891.0	19701.5
1690	16728.0	16851.0	16152	16764.0	16882.0	16214	16795.0		1843	18891.5	19702.0
1691	16728.5	16851.5	16153	16764.5	16882.5	16215	16795.5		1844	18892.0	19702.5
1692	16729.0	16852.0	16154	16765.0	16883.0	16216	16796.0		1845	18892.5	19703.0
1693	16729.5	16852.5	16155	16765.5	16883.5	16217	16796.5		1846	18893.0	
1694	16730.0	16853.0	16156	16766.0	16884.0	16218	16797.0		1847	18893.5	
1695	16730.5	16853.5	16157	16766.5	16884.5	16219	16797.5		1848	18894.0	
1696	16731.0	16854.0	16158	16767.0	16885.0	16220	16798.0		1849	18894.5	
1697	16731.5	16854.5	16159	16767.5	16885.5	16221	16798.5		1850	18895.0	
1698	16732.0	16855.0	16160	16768.0	16886.0	16222	16799.0		1851	18895.5	
1699	16732.5	16855.5	16161	16768.5	16886.5	16223	16799.5		1852	18896.0	
16100	16733.0	16856.0	16162	16769.0	16887.0	16224	16800.0		1853	18896.5	
16101	16733.5	16856.5	16163	16769.5	16887.5	16225	16800.5		1854	18897.0	
16102	16739.0	16857.0	16164	16770.0	16888.0	16226	16801.0		1855	18897.5	
16103	16739.5	16857.5	16165	16770.5	16888.5	16227	16801.5		1856	18898.0	
16104	16740.0	16858.0	16166	16771.0	16889.0	16228	16802.0				
16105	16740.5	16858.5	16167	16771.5	16889.5	16229	16802.5		2201	22284.5	22376.5
16106	16741.0	16859.0	16168	16772.0	16890.0	16230	16803.0		2202	22285.0	22377.0
16107	16741.5	16859.5	16169	16772.5	16890.5	16231	16803.5		2203	22285.5	22377.5
16108	16742.0	16860.0	16170	16773.0	16891.0	16232	16804.0		2204	22286.0	22378.0
16109	16742.5	16860.5	16171	16773.5	16891.5				2205	22286.5	22378.5
16110	16743.0	16861.0	16172	16774.0	16892.0	1801	18870.5	19681.0	2206	22287.0	22379.0
16111	16743.5	16861.5	16173	16774.5	16892.5	1802	18871.0	19681.5	2207	22287.5	22379.5
16112	16744.0	16862.0	16174	16775.0	16893.0	1803	18871.5	19682.0	2208	22288.0	22380.0
16113	16744.5	16862.5	16175	16775.5	16893.5	1804	18872.0	19682.5	2209	22288.5	22380.5
16114	16745.0	16863.0	16176	16776.0	16894.0	1805	18872.5	19683.0	2210	22289.0	22381.0
16115	16745.5	16863.5	16177	16776.5	16894.5	1806	18873.0	19683.5	2211	22289.5	22381.5
16116	16746.0	16864.0	16178	16777.0	16895.0	1807	18873.5	19684.0	2212	22290.0	22382.0
16117	16746.5	16864.5	16179	16777.5	16895.5	1808	18874.0	19684.5	2213	22290.5	22382.5
16118	16747.0	16865.0	16180	16778.0	16896.0	1809	18874.5	19685.0	2214	22291.0	22383.0
16119	16747.5	16865.5	16181	16778.5	16896.5	1810	18875.0	19685.5	2215	22291.5	22383.5
16120	16748.0	16866.0	16182	16779.0	16897.0	1811	18875.5	19686.0	2216	22292.0	22384.0
16121	16748.5	16866.5	16183	16779.5	16897.5	1812	18876.0	19686.5	2217	22292.5	22384.5

Channel			Channel			Channel			Channel		
Designator	Ship Tx	Ship Rx	Designator	Ship Tx	Ship Rx	Designator	Ship Tx	Ship Rx	Designator	Ship Tx	Ship Rx
(Telex)			2279	22323.5	22415.5	22141	22354.5		2522	25183.5	26111.5
2218	22293.0	22385.0	2280	22324.0	22416.0	22142	22355.0		2523	25184.0	26112.0
2219	22293.5	22385.5	2281	22324.5	22416.5	22143	22355.5		2524	25184.5	26112.5
2220	22294.0	22386.0	2282	22325.0	22417.0	22144	22356.0		2525	25185.0	26113.0
2221	22294.5	22386.5	2283	22325.5	22417.5	22145	22356.5		2526	25185.5	26113.5
2222	22295.0	22387.0	2284	22326.0	22418.0	22146	22357.0		2527	25186.0	26114.0
2223	22295.5	22387.5	2285	22326.5	22418.5	22147	22357.5		2528	25186.5	26114.5
2224	22296.0	22388.0	2286	22327.0	22419.0	22148	22358.0		2529	25187.0	26115.0
2225	22296.5	22388.5	2287	22327.5	22419.5	22149	22358.5		2530	25187.5	26115.5
2226	22297.0	22389.0	2288	22328.0	22420.0	22150	22359.0		2531	25188.0	26116.0
2227	22297.5	22389.5	2289	22328.5	22420.5	22151	22359.5		2532	25188.5	26116.5
2228	22298.0	22390.0	2290	22329.0	22421.0	22152	22360.0		2533	25189.0	26117.0
2229	22298.5	22390.5	2291	22329.5	22421.5	22153	22360.5		2534	25189.5	26117.5
2230	22299.0	22391.0	2292	22330.0	22422.0	22154	22361.0		2535	25190.0	26118.0
2231	22299.5	22391.5	2293	22330.5	22422.5	22155	22361.5		2536	25190.5	26118.5
2232	22300.0	22392.0	2294	22331.0	22423.0	22156	22362.0		2537	25191.0	26119.0
2233	22300.5	22392.5	2295	22331.5	22423.5	22157	22362.5		2538	25191.5	26119.5
2234	22301.0	22393.0	2296	22332.0	22424.0	22158	22363.0		2539	25192.0	26120.0
2235	22301.5	22393.5	2297	22332.5	22424.5	22159	22363.5		2540	25192.5	26120.5
2236	22302.0	22394.0	2298	22333.0	22425.0	22160	22364.0		2541	25193.0	
2237	22302.5	22394.5	2299	22333.5	22425.5	22161	22364.5		2542	25193.5	
2238	22303.0	22395.0	22100	22334.0	22426.0	22162	22365.0		2543	25194.0	
2239	22303.5	22395.5	22101	22334.5	22426.5	22163	22365.5		2544	25194.5	
2240	22304.0	22396.0	22102	22335.0	22427.0	22164	22366.0		2545	25195.0	
2241	22304.5	22396.5	22103	22335.5	22427.5	22165	22366.5		2546	25195.5	
2242	22305.0	22397.0	22104	22336.0	22428.0	22166	22367.0		2547	25196.0	
2243	22305.5	22397.5	22105	22336.5	22428.5	22167	22367.5		2548	25196.5	
2244	22306.0	22398.0	22106	22337.0	22429.0	22168	22368.0		2549	25197.0	
2245	22306.5	22398.5	22107	22337.5	22429.5	22169	22368.5		2550	25197.5	
2246	22307.0	22399.0	22108	22338.0	22430.0	22170	22369.0		2551	25198.0	
2247	22307.5	22399.5	22109	22338.5	22430.5	22171	22369.5		2552	25198.5	
2248	22308.0	22400.0	22110	22339.0	22431.0	22172	22370.0		2553	25199.0	
2249	22308.5	22400.5	22111	22339.5	22431.5	22173	22370.5		2554	25199.5	
2250	22309.0	22401.0	22112	22340.0	22432.0	22174	22371.0		2555	25200.0	
2251	22309.5	22401.5	22113	22340.5	22432.5	22175	22371.5		2556	25200.5	
2252	22310.0	22402.0	22114	22341.0	22433.0	22176	22372.0		2557	25201.0	
2253	22310.5	22402.5	22115	22341.5	22433.5	22177	22372.5		2558	25201.5	
2254	22311.0	22403.0	22116	22342.0	22434.0	22178	22373.0		2559	25202.0	
2255	22311.5	22403.5	22117	22342.5	22434.5	22179	22373.5		2560	25202.5	
2256	22312.0	22404.0	22118	22343.0	22435.0	22180	22374.0		2561	25203.0	
2257	22312.5	22404.5	22119	22343.5	22435.5				2562	25203.5	
2258	22313.0	22405.0	22120	22344.0	22436.0	2501	25173.0	26101.0	2563	25204.0	
2259	22313.5	22405.5	22121	22344.5	22436.5	2502	25173.5	26101.5	2564	25204.5	
2260	22314.0	22406.0	22122	22345.0	22437.0	2503	25174.0	26102.0	2565	25205.0	
2261	22314.5	22406.5	22123	22345.5	22437.5	2504	25174.5	26102.5	2566	25205.5	
2262	22315.0	22407.0	22124	22346.0	22438.0	2505	25175.0	26103.0	2567	25206.0	
2263	22315.5	22407.5	22125	22346.5	22438.5	2506	25175.5	26103.5	2568	25206.5	
2264	22316.0	22408.0	22126	22347.0	22439.0	2507	25176.0	26104.0	2569	25207.0	
2265	22316.5	22408.5	22127	22347.5	22439.5	2508	25176.5	26104.5	2570	25207.5	
2266	22317.0	22409.0	22128	22348.0	22440.0	2509	25177.0	26105.0	2571	25208.0	
2267	22317.5	22409.5	22129	22348.5	22440.5	2510	25177.5	26105.5			
2268	22318.0	22410.0	22130	22349.0	22441.0	2511	25178.0	26106.0			
2269	22318.5	22410.5	22131	22349.5	22441.5	2512	25178.5	26106.5			
2270	22319.0	22411.0	22132	22350.0	22442.0	2513	25179.0	26107.0			
2271	22319.5	22411.5	22133	22350.5	22442.5	2514	25179.5	26107.5			
2272	22320.0	22412.0	22134	22351.0	22443.0	2515	25180.0	26108.0			
2273	22320.5	22412.5	22135	22351.5	22443.5	2516	25180.5	26108.5			
2274	22321.0	22413.0	22136	22352.0		2517	25181.0	26109.0			
2275	22321.5	22413.5	22137	22352.5		2518	25181.5	26109.5			
2276	22322.0	22414.0	22138	22353.0		2519	25182.0	26110.0			
2277	22322.5	22414.5	22139	22353.5		2520	25182.5	26110.5			
2278	22323.0	22415.0	22140	22354.0		2521	25183.0	26111.0			