

**MF/HF Radio Equipment**

**JSS-296**

**Instruction Manual**

**JRC** *Japan Radio Co., Ltd.*



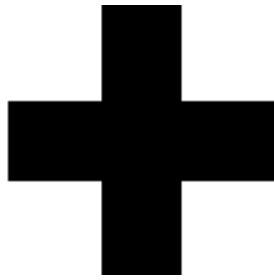

## **CAUTIONS AGAINST HIGH VOLTAGE**

Radio and radar devices are operated by high voltages of anywhere from a few hundred volts up to many hundreds of thousands of volts. Although there is no danger with normal use, it is very dangerous if contact is made with the internal parts of these devices. (Only specialists should attempt any maintenance, checking or adjusting.)

There is a very high risk of death by even a few thousand volts, in some cases you can be fatally electrocuted by just a few hundred volts. To circumvent accidents, you should avoid contact with the internal parts of these devices at all costs. If contact is inevitable as in the case of an emergency, you must switch off the devices and ground a terminal in order to discharge the capacitors. After making certain that all the electricity is discharged, only then can you insert your hand into the device. Wearing cotton gloves and putting your free hand in your pocket, in order not to use both hands simultaneously, are also very good methods of shock prevention.

Quite often, an injury occurs by secondary factors, therefore it is necessary to choose a sturdy and level working surface. If someone is electrocuted it is necessary to thoroughly disinfect the affected area and seek medical attention as soon as possible.

## **Cautions concerning treatment of electrocution victims**

When you find an electrocution victim, you must first switch off the machinery and ground all circuits. If you are unable to cut off the machinery, move the victim away from it using a non-conductive material such as dry boards or clothing.

When someone is electrocuted, and the electrical current reaches the breathing synapses of the central nervous system inside the brain, breathing stops. If the victim's condition is stable, he or she can be administered artificial respiration. An electrocution victim becomes very pale, and their pulse can be very weak or even stop, consequently losing consciousness and becoming stiff.

Administration of first aid is critical in this situation.

# First aid

## Note points for first aid

Unless there is impending danger leave the victim where he or she is, then begin artificial respiration. Once you begin artificial respiration, you must continue without losing rhythm.

- (1) Make contact with the victim cautiously, there is a risk that you may get electrocuted.
- (2) Switch off the machinery and then move the victim away slowly if you must.
- (3) Inform someone immediately (a hospital or doctor, dial emergency numbers, etc.).
- (4) Lay the victim on his or her back and loosen any constrictive clothing (a tie, or belt).
- (5)
  - (a) Check the victim's pulse.
  - (b) Check for a heartbeat by pressing your ear against the victim's chest.
  - (c) Check if the victim is breathing by putting the back of your hand or face near the victim's face.
  - (d) Check the pupils of the eyes.
- (6) Open the victim's mouth and remove any artificial dentifrice, food or chewing gum. Leave the mouth opened and flatten the tongue with a towel or by putting something into the mouth to prevent the victim's tongue from obstructing the throat. (If he or she is clenching their teeth and it is difficult to open the mouth, use a spoon or the like to pry open the mouth.)
- (7) Continually wipe the mouth to prevent the accumulation of saliva.

## If the victim has a pulse but is not breathing ("Mouth to mouth" resuscitation) Figure 1.

- (1) Place the victim's head facing backward (place something under the neck like a pillow).
- (2) Point the chin upward to widen the trachea.
- (3) Pinch the victim's nose, take a deep breath, then put your mouth over the victim's mouth and exhale completely, making sure that your mouth completely covers the victim's mouth. Then remove your mouth. Repeat this routine 10 to 15 times per minute (holding the nostrils).
- (4) Pay attention to the victim to notice if he or she starts to breath. If breathing returns, stop resuscitation.
- (5) If it is impossible to open the victim's mouth, put something like a plastic straw or vinyl tube into one of the nostrils then blow air in while covering the mouth and the other nostril.
- (6) Occasionally, when the victim comes back to consciousness, they immediately try to stand up. Prevent this and keep them in a laying position. Give them something warm to drink and be sure that they rest (do not give them any alcohol).

### Administering artificial respiration by raising the head.

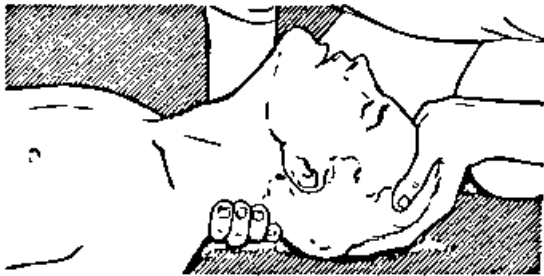
- 

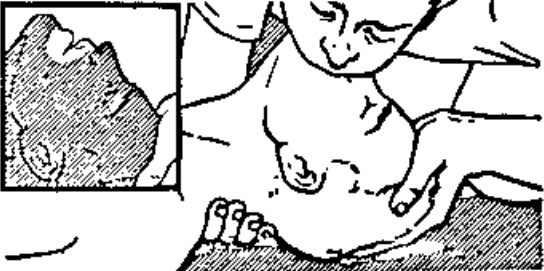
(1) Raise the back of the head, then place one hand on the forehead and place the other hand under the neck. →①  
Most victims open their mouth when doing this, making "mouth to mouth" resuscitation easier.
- 

(2) Cover the victim's mouth by opening your mouth widely, then push your cheek against the victim's nose, →②  
or pinch the victim's nose to prevent air from leaking out of it. →③
- 

(3) Completely exhale into the lungs.  
Exhale into the lungs until the chest is inflates.  
You have to blow as rapidly as possible for the first 10 times.

("Mouth to mouth" resuscitation) Figure 1.

## **If the victim has no pulse and is not breathing (Heart massage in combination with artificial respiration.) Figure 2**

If the victim has no pulse, his or her pupils are dilated, and if you cannot detect a heartbeat, the heart may have stopped, beginning artificial respiration is critical.

- (1) Put both hands on the diaphragm, with hands on top of each other keeping both arms straight. (If your elbows are bent, you cannot push with as much power.) Press the diaphragm with your body weight until the chest sinks about 2 cm (about 50 times per minute).
- (2) If administering first aid when alone:  
Perform the heart massage about 15 times then blow in twice. Repeat this routine.  
If administering first aid with two people:  
One person performs the heart massage 5 times, and the other person blows air in once. Repeat this routine. (Heart massage and "mouth to mouth" resuscitation used together.)
- (3) Constantly check the pupils and the pulse, if the pupils become normal and the pulse steadies, keep them in a laying position and give them something warm to drink, be sure that they rest (do not give them any alcohol.). In any case you have to entrust major decision making to a doctor. Having understanding people around is essential to the victim's recovery from the mental shock of electrocution.

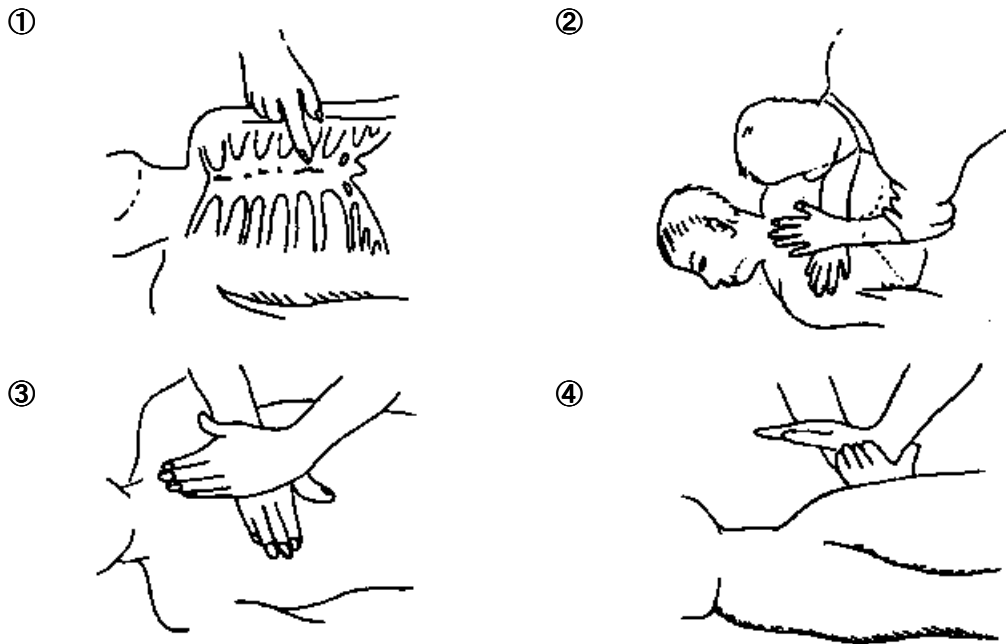

(Heart massage in combination with artificial respiration.) Figure 2

## **Preface**



Thank you for purchasing JRC MF/HF Radio Equipment model JSS-296.

For best operation and performance results, read this manual thoroughly before use.  
Keep this manual in a convenient place for future reference. Make use of this manual when experiencing operation difficulties.

## Before Operation

### Concerning the symbols

This manual uses the following symbols to explain correct operation and to prevent injury or damage to property. The symbols and descriptions are as follows. Understand them before proceeding with reading this manual.

 <b>WARNING</b>	Indicates a warning that, if ignored, may result in serious injury or even death.
 <b>CAUTION</b>	Indicates a caution that, if ignored, may result in injury or damage to property.

### Examples of symbols



The  $\triangle$  symbol indicates caution (including DANGER and WARNING). The illustration inside the  $\triangle$  symbol specifies the content of the caution more accurately. (This example is a general caution.)



The  $\circledR$  symbol indicates that performing an action is prohibited. The illustration inside or next to the  $\circledR$  symbol specifies the contents of the prohibited operation. (In this example, disassembly is prohibited.)



The  $\circledL$  symbol indicates operations that must be performed. The illustration inside the  $\circledL$  symbol specifies the obligatory operation. (In the example, unplugging is the obligatory operation.)

### Concerning warning labels

A warning label is pasted to the top cover of this product. Do not remove, damage, or modify the label.



## Handling Precautions

# WARNING



Do not disassemble or modify this unit. Doing so may cause fire, electrical shock, or failure.



Do not use a voltage other than specified. Doing so may cause fire, electrical shock, or failure.



If you remove a unit, be sure to store it in a non-conductive bag. If you wrap it up with materials such as aluminum foil, the back-up power supply may short circuit and the ICs may be damaged.



There are no user-serviceable parts inside this equipment. Inspection or maintenance by unauthorized persons may result in fire or electric shock. For inspection and maintenance, contact JRC or its authorized agents.

## Handling Precautions

# CAUTION



Do not use this equipment in an environment other than that specified. Doing so may cause failure or malfunction.



Do not turn the trimmer resistors or trimmer capacitors on the PCB unit (they are preset at the factory). Doing so may cause failure or malfunction.



Do not install the equipment in a place near water or in one with excessive humidity, steam, dust or soot. Doing so may cause fire, electric shock, or failure.



Do not get this equipment wet or spill any liquids on or near this equipment. Doing so may cause electrical shock or failure.



Do not place this equipment anywhere vibration or impact is likely to occur. Doing so may cause a failure or injury.



Do not place anything on top of this equipment. Doing so may cause fire or failure.



Leave installation of this equipment to JRC or our agents. Installation by an unauthorized person may lead to malfunction.



Be sure to turn OFF the printer's power when opening and closing the printer cover. Failure to comply could result in electrical shock, failure, or injury.



Just after printing, the temperature of the printing head is high. Do not touch the printing head until the temperature goes down. Doing so may cause a burn or an injury.



Do not touch any part of the cutter. Doing so is potentially dangerous.

# DISTRESS CALLS

## NCT-196N

There are three methods of transmitting a distress call. These methods are described below in order of ease of use, with the easiest first.

### Transmitting Distress Calls 1

#### Procedure

1. Open the cover on the left and press **DISTRESS** .  
The following screen is displayed.

```
DISTRESS CALL          Transmissible
▶Address               : XXXXXXXXXX
Nature                 : UNDESIGNATED DIST
Dist-position          : 12° 34' N123° 45' E
Dist-UTC               : 01:26
Dist-telecomm          : J3E TEL
End of sequence        : EOS
Call TX/RX freq:      2,187.5/ 2,187.5 kHz
```

**Note** • If stop the distress transmission, press **STOP** .

2. Press **DISTRESS** for 3.5 seconds continuously.

**Note** • If stop the distress transmission, release **DISTRESS** .

3. The following screen is displayed and the distress transmission is started.  
If a printer is connected, it prints out the distress message.  
The distress message is transmitted for 5 times successively.

```
DISTRESS CALL          Transmitting
TX frequency           : 2,187.5 kHz
TX date&time           : 06.Sep.2001(Thu) 01:26
                                                                1/5
```

**Note** • If break the distress transmission, press **STOP** .

4. **When the distress transmission is completed, the screen is displayed as follows for a few seconds.**

DISTRESS CALL	Send Completed
TX frequency	: 2,187.5 kHz
TX date&time	:06.Sep.2001(Thu) 01:27
	5/5

5. **The distress transmission is repeated at random intervals of 3.5 to 4.5 minutes.**  
On completion of the transmission, the screen is changed as follows. And the distress transmission is repeated when the displayed time has counted down to zero.

DISTRESS CALL	2,187.5 kHz
NEXT DISTRESS CALL	: AFTER 3.0 min

# Transmitting Distress Calls 2

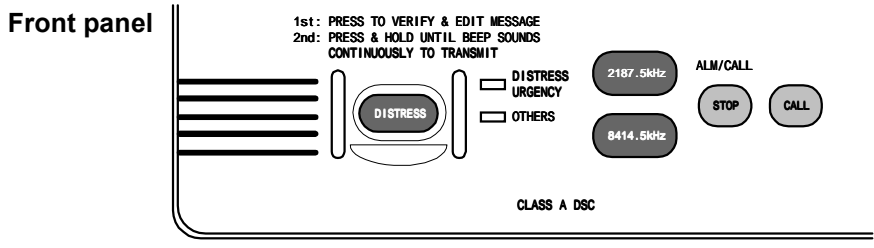

## Procedure

1. Press **2187.5kHz** or **8414.5kHz** .
  
2. Open the cover on the left and press **DISTRESS** .  
The following screen is displayed.

```

DISTRESS CALL           Transmissible
▶Address                : XXXXXXXXXX
Nature                  : UNDESIGNATED DIST
Dist-position           : 12° 34' N123° 45' E
Dist-UTC                : 01:26
Dist-telecomm           : J3E TEL
End of sequence         : EOS
Call TX/RX freq         : 2,187.5/ 2,187.5 kHz
    
```

**Note** • If stop the distress transmission, press **STOP** .

3. Press **DISTRESS** for 3.5 seconds at least.

**Note** • If stop the distress transmission, release **DISTRESS** .

4. The following screen is displayed and the distress transmission is started.  
If a printer is connected, it prints out the distress message.  
The distress message is transmitted for 5 times successively.

```

DISTRESS CALL           Transmitting
TX frequency            : 2,187.5 kHz
TX date&time            : 06.Sep.2001 (Thu) 01:26
                                                                1/5
    
```

**Note** • If break the distress transmission, press **STOP** .

5. **When the distress transmission is completed, the screen is displayed as follows for a few seconds.**

DISTRESS CALL	Send Completed
TX frequency	: 2,187.5 kHz
TX date&time	:06.Sep.2001(Thu) 01:27
	5/5

6. **The distress transmission is repeated at random intervals of 3.5 to 4.5 minutes.**  
On completion of the transmission, the screen is changed as follows. And the distress transmission is repeated when the displayed time has counted down to zero.

DISTRESS CALL	2,187.5 kHz
NEXT DISTRESS CALL	: AFTER 3.0 min

# Transmitting Distress Calls 3

The NCT-196N enables an operator to create and edit messages for transmission.

### Procedure

1. Confirm that the "DSC watching" screen is displayed.

```
DSC watching 06.Sep.2001(Thu) 01:26
12°34'N123°45'E SPEED:12.4KT at 01:26

Self-ID = XXXXXXXXXX [UTC]
```

2. Press **MENU**.

The "MENU #1-EDIT&CALL" screen is displayed.

```
MENU #1-EDIT&CALL      Select no._
▶ 1.Individual call
  2.Acknowledgement call
  3.Distress call
  4.Distress relay call
  5.Auto/semi-auto call
  6.All ships call
  7.Group call
  8.Area call
  9.Position request
 10.Polling call
 11.Test call
```

Use  and  to scroll the screen.

3. Press **3** and then **ENT** to select "3. Distress call".

The "Distress Call" screen is displayed as follows. Then setup these items except for "Address" and "End of sequence" properly.

```
DISTRESS CALL      Transmissible
▶Address           : XXXXXXXXXX
Nature            : UNDESIGNATED DIST
Dist-position     : 31°00'N 135°00'E
Dist-UTC          : 01:26
Dist-telecomm     : J3E TEL
End of sequence   : EOS
Call TX/RX freq  : 2,187.5/ 2,187.5 kHz
```

Use  and  to scroll the screen.

4. Open the cover on the left and press **DISTRESS** for 3.5 seconds at least.
5. The following screen is displayed and the distress transmission is started.  
If a printer is connected, it prints out the distress message.  
The distress message is transmitted for 5 times successively.

```
DISTRESS CALL      Transmitting
TX frequency       : 2,187.5 kHz
TX date&time      : 06.Sep.2001(Thu) 01:26
                                                         1/5
```

**Note** • If break the distress transmission, press **STOP**.

6. When the distress transmission is completed, the screen is displayed as follows for a few seconds.

```
DISTRESS CALL          Send Completed
TX frequency   : 2,187.5 kHz
TX date&time   : 06.Sep.2001 (Thu) 01:27
                                     5/5
```

7. The distress transmission is repeated at random intervals of 3.5 to 4.5 minutes. On completion of the transmission, the screen is changed as follows. And the distress transmission is repeated when the displayed time has counted down to zero.

```
DISTRESS CALL          2,187.5 kHz
NEXT DISTRESS CALL : AFTER 3.0 min
```

## Receiving Distress Calls

When a distress call is received, the "DISTRESS/URGENCY" LED lights up in red and the alarm tone sounds. Up to 20 received distress calls are automatically stored in memory for future confirmation.

### Note

The distress messages are automatically deleted 48 hours after they have been received in order to prevent unnecessary distress message relay transmission. Thus the distress messages more than 48 hours old cannot be displayed but it is a proper transaction.

### ATTENTION

When a distress call is received, inform the ship's captain or officer in charge and log the distress call. There are legal repercussions if such a procedure is not followed. Furthermore if a distress call is received, make contact immediately according to "RECEPTION OF DSC DISTRESS ALERT".



# CONTENTS

<b>CAUTIONS AGAINST HIGH VOLTAGE .....</b>	<b>i</b>
<b>Cautions concerning treatment of electrocution victims.....</b>	<b>i</b>
<b>First aid .....</b>	<b>ii</b>
<b>Preface .....</b>	<b>v</b>
<b>Before Operation .....</b>	<b>vi</b>
<b>Handling Precautions.....</b>	<b>vii</b>
<b>1. INTRODUCTION .....</b>	<b>1-1</b>
1.1 Outlines.....	1-1
1.2 Features.....	1-1
1.3 Configuration .....	1-2
1.4 External View.....	1-4
1.5 Block Diagram .....	1-6
<b>2. PART NAMES AND FUNCTIONS.....</b>	<b>2-1</b>
<b>3. OPERATIONS .....</b>	<b>3-1</b>
3.1 System Standby .....	3-1
3.1.1 Turning the Power ON .....	3-1
3.1.2 Turning the Power OFF .....	3-1
3.2 Mode Change .....	3-2
3.2.1 Mode change to DSC .....	3-2
3.2.2 Mode change to TLX .....	3-3
3.3 Setting Position and Time Data .....	3-4
3.3.1 Setting the Internal Clock (DATA&TIME EDIT).....	3-4
3.3.2 Specifying Position Input (POSITION EDIT) .....	3-6
3.4 Radiotelephone operations .....	3-7
3.4.1 Turning the Power ON/OFF .....	3-7
3.4.1.1 Turning the Power ON.....	3-7
3.4.1.2 Turning the Power OFF .....	3-7
3.4.2 Communication Procedure .....	3-8
3.4.2.1 Setting the channel number with the Jog Dial.....	3-8
3.4.2.2 Monitoring the transmissio frequency .....	3-9
3.4.2.3 Setting the channel number with keypad .....	3-9
3.4.2.4 Manually inputting frequency .....	3-10
3.4.2.5 Scanning reception .....	3-11
3.4.3 Other Functio Settings .....	3-12
3.4.3.1 Setting the communication mode.....	3-12
3.4.3.2 Setting the uotput power .....	3-13
3.4.3.3 Turning the Automatic Gain Control(AGC)ON .....	3-13
3.4.3.4 Adjusting squelch Level .....	3-14
3.4.3.5 Setting the scanning speed.....	3-15
3.4.3.6 Registering the User channel.....	3-15
3.4.3.7 Registering a channel group name .....	3-17
3.4.3.8 Setting the meter indication mode.....	3-18
3.4.3.9 Setting the Automatic Tuning Start(ATS) .....	3-18

3.4.3.10	Setting the wait time for ATS .....	3-19
3.4.3.11	Turning the key-in sounds ON/OFF .....	3-19
3.4.3.12	Setting the loudspeaker output ON/OFF .....	3-20
3.4.3.13	List of shortcut keys .....	3-21
3.5	DSC operations .....	3-23
3.5.1	Menus and Modes .....	3-23
3.5.2	Receiving Messages .....	3-25
3.5.3	Sending Messages .....	3-29
3.5.4	Other Functions .....	3-63
3.6	NBDP operations .....	3-75
3.6.1	NBDP Settings Menus and Modes .....	3-75
3.6.2	ARQ Communication .....	3-77
3.6.3	FEC Communication .....	3-81
3.6.3.1	SFEC Communication .....	3-81
3.6.3.2	CFEC Communication .....	3-83
3.6.4	Scanning for TLX mode .....	3-85
3.6.4.1	Scanning start .....	3-85
3.6.4.2	Scanning stop .....	3-86
3.7	PA operations .....	3-87
3.7.1	AC/DC power source voltage checking .....	3-87
3.7.2	DC (Battery) charge/discharge current checking .....	3-87
3.7.3	RF current of Antenna and PA checking .....	3-88
3.7.4	PA voltage (Vc) and current (Ic) checking .....	3-89
3.7.5	SWR of PA output checking .....	3-90
3.7.6	Beeping sound ON/OFF setting .....	3-91
3.7.7	PA alarm sound ON/OFF setting .....	3-91
3.7.8	Battery charge mode (Ordinary/Equal) setting .....	3-92
3.7.9	DC operation .....	3-92
3.8	Printer operations .....	3-93
3.8.1	Names and Functions .....	3-94
3.8.2	Operation Panel .....	3-95
3.8.3	Opening/Closing the Printer Cover .....	3-96
3.8.4	Replacing the Roll Paper .....	3-98
3.8.5	Replacing the Ribbon Cassette Cartridge .....	3-102
3.8.6	Adjusting the Printing Pressure (to Printing Paper Thickness) .....	3-104
3.8.7	Setting the DIP Switch .....	3-105
3.8.8	How to Attend to Error Detection .....	3-107
<b>4.</b>	<b>MAINTENANCE AND INSPECTION .....</b>	<b>4-1</b>
4.1	General Maintenance and Inspection .....	4-2
<b>5.</b>	<b>AFTER-SALES SERVICE .....</b>	<b>5-1</b>
5.1	Before returning repair .....	5-1
5.2	Periodical maintenance recommended .....	5-1
<b>6.</b>	<b>SPECIFICATIONS .....</b>	<b>6-1</b>

## Abbreviations

AM:	Amplitude Modulation. The carrier amplitude is modulated in accordance with the signal.
AMVER:	Automated Mutual-assistance Vessel Rescue System
ARQ:	Automatic Repeat Request
ASCII:	American Standard Code for Information Interchange
ATS:	Automatic Tuning Start
ATU:	Antenna Tuner
AUTO TELEX:	A kind of Telex communication. The line is automatically established by receiving a free signal transmitted from a coast station.
CFEC:	Collective Forward Error Correcting. A mode transmitting to many and unspecified stations.
CIRM:	Committee International Radio Maritime
COMSAR:	Sub-committee on Radio Communications and Search and Rescue
DIM:	Dimmer
DSC:	Digital Selective Calling
DTE:	Data Terminal Equipment
FEC:	Forward Error Correction System
GMDSS:	Global Maritime Distress and Safety System
GPS:	Global Positioning System
HF:	High Frequency

IMO:	International Maritime Organization
ITU:	International Telecommunication Union. Regulates the treaty and rules relating to the telecommunication of wire, wireless, land wires, marine, air and space. As internal machinery, there are WARC, CCIR, CCITT and others.
MF:	Medium Frequency (300 kHz to 3 MHz)
NBDP:	Narrow Band Direct Printing
NNSS:	Navy Navigation Satellite System
PC:	Personal Computer
RCC:	Rescue Coordinate Center
RR:	Radio Regulations
SAR:	Search and Rescue
SFEC:	Selective Forward Error Correcting. Destination is specified and transmitted in this mode.
SOLAS:	International Convention for the Safety of Life at Sea
SSB:	Single Side Band
UTC:	Universal Time Coordinated

# 1. INTRODUCTION

## 1.1 Outlines

The JSS-296 MF/HF Radio Equipment is designed for vessels navigating A2, A3 and A4 sea areas. It consists of mainly the JSB-196GM Radiotelephone, NFC-296 Antenna Tuning Unit (ATU), NCT-196N DSC/NBDP MODEM, NDZ-127J Data Terminal Equipment (DTE), NDF-268 Keyboard, and NAH-692 Power Amplifier, and it provides the optimum GMDSS system for the superior performance, compact, lightweight and highly efficient design of the units, which ensures easy operation for distress and safety calling as well as general communications.

## 1.2 Features

### **Fully Complies with GMDSS Requirements**

---

All the functions required by IMO resolutions A.804 (19) and A.806 (19) are equipped, and suitable for radio installations of vessels navigating A2, A3 and A4 sea areas.

### **Inadvertent Distress Alert Protection**

---

The DISTRESS button is protected by a cover to prevent inadvertent distress alert transmission.

### **AC/DC Two-way Power Supply**

---

The Power Supply equipped in the NAH-692 Power Amplifier is connected to both AC mains and auxiliary DC24V battery, and can switch them automatically.

### **Selfcheck Function**

---

A Built-in high grade selfcheck function centrally controlled using JSB-196GM Radiotelephone ensures easy maintenance.

### **Built-in Dummy Load for ATU Selfcheck**

---

The dummy load for checking the NFC-296 Antenna Tuning Unit (ATU) is built-in and not required to connect as extra unit.

### **Outdoor Installable Antenna Tuning Unit**

---

The NFC-296 Antenna Tuning Unit can be installed outdoors such as on deck, ensuring effective emission of transmitter power.

## 1.3 Configuration

### WARNING



Do not disassemble or modify this unit. Doing so may cause fire, electrical shock, or failure.



Do not use a voltage other than specified. Doing so may cause fire, electrical shock, or failure.

### CAUTION



Do not use this equipment in an environment other than that specified. Doing so may cause failure or malfunction.



Do not install the equipment in a place near water or in one with excessive humidity, steam, dust or soot. Doing so may cause fire, electric shock, or failure.



Do not get this equipment wet or spill any liquids on or near this equipment. Doing so may cause electrical shock or failure.



Do not place this equipment anywhere vibration or impact is likely to occur. Doing so may cause a failure or injury.



Do not place anything on top of this equipment. Doing so may cause fire or failure.

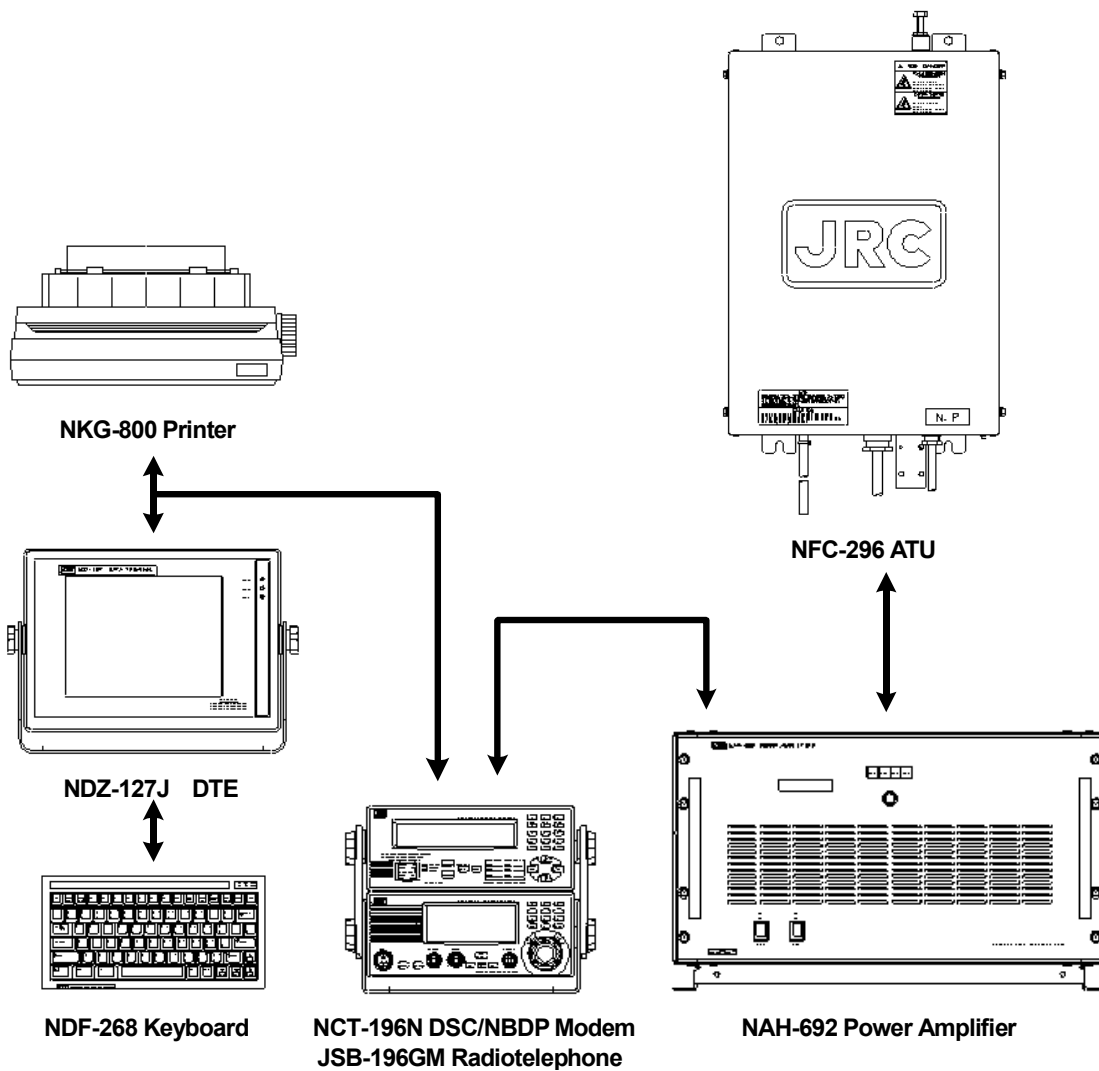

# 1.4 External View

## JSB-196GM Radiotelephone

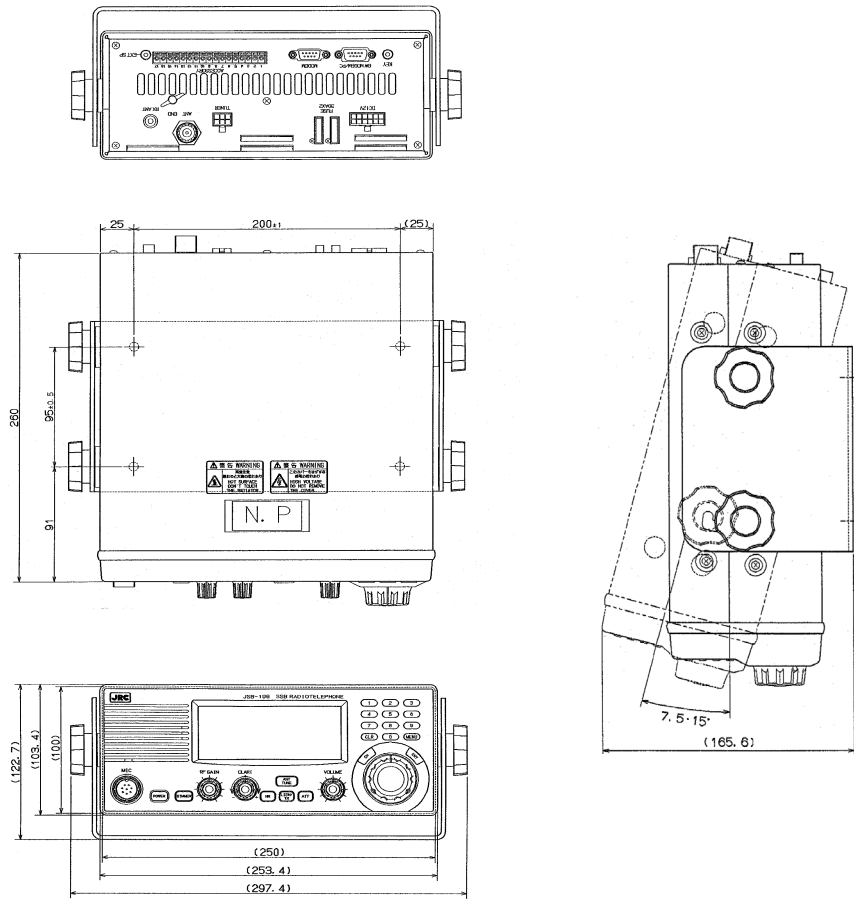

(Unit: mm)

## NFC-296 Antenna Tuner

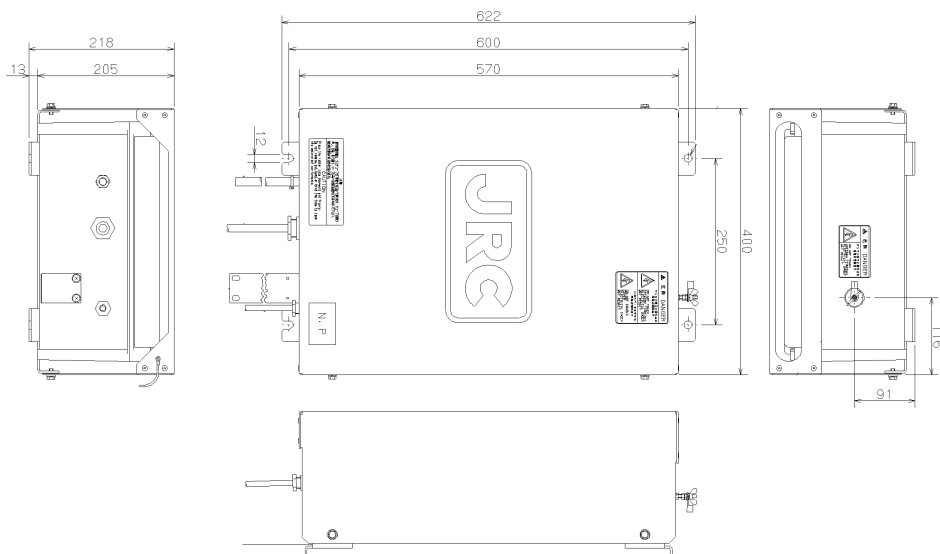

(Unit: mm)



## NCT-196N DSC/NBDP Modem

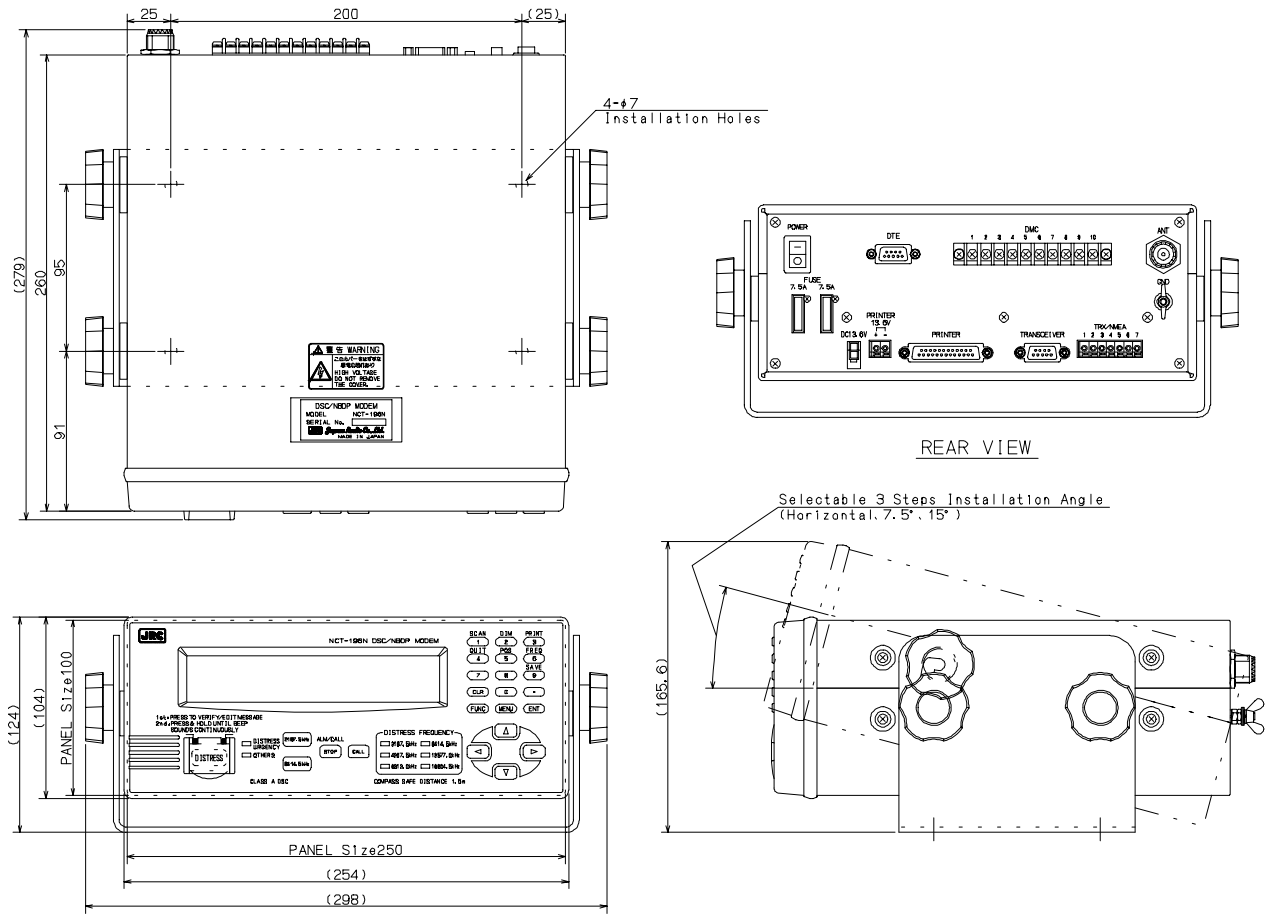

(Unit: mm)

## NAH-692 Power Amplifier

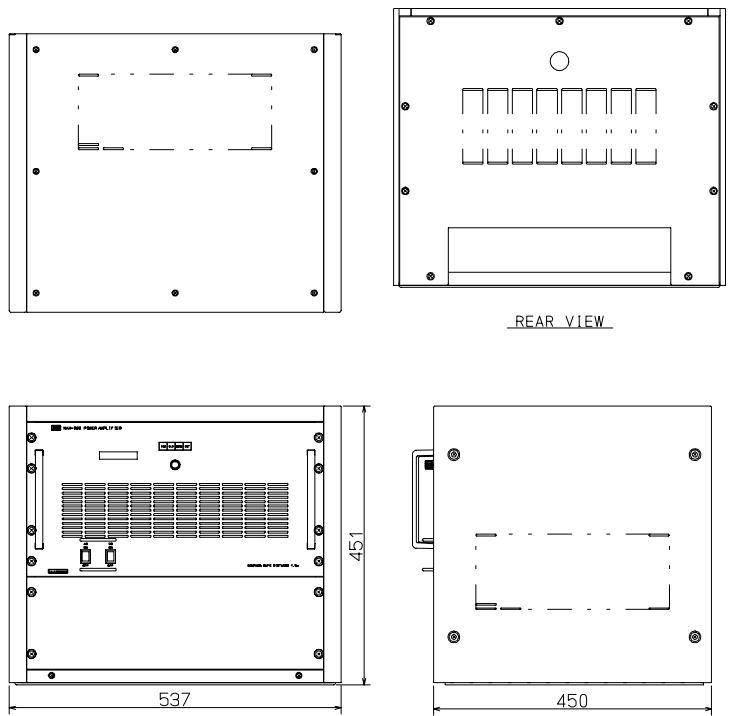

(Unit: mm)

# 1.5 Block Diagram

## JSB-196GM MF/HF Radio Equipment

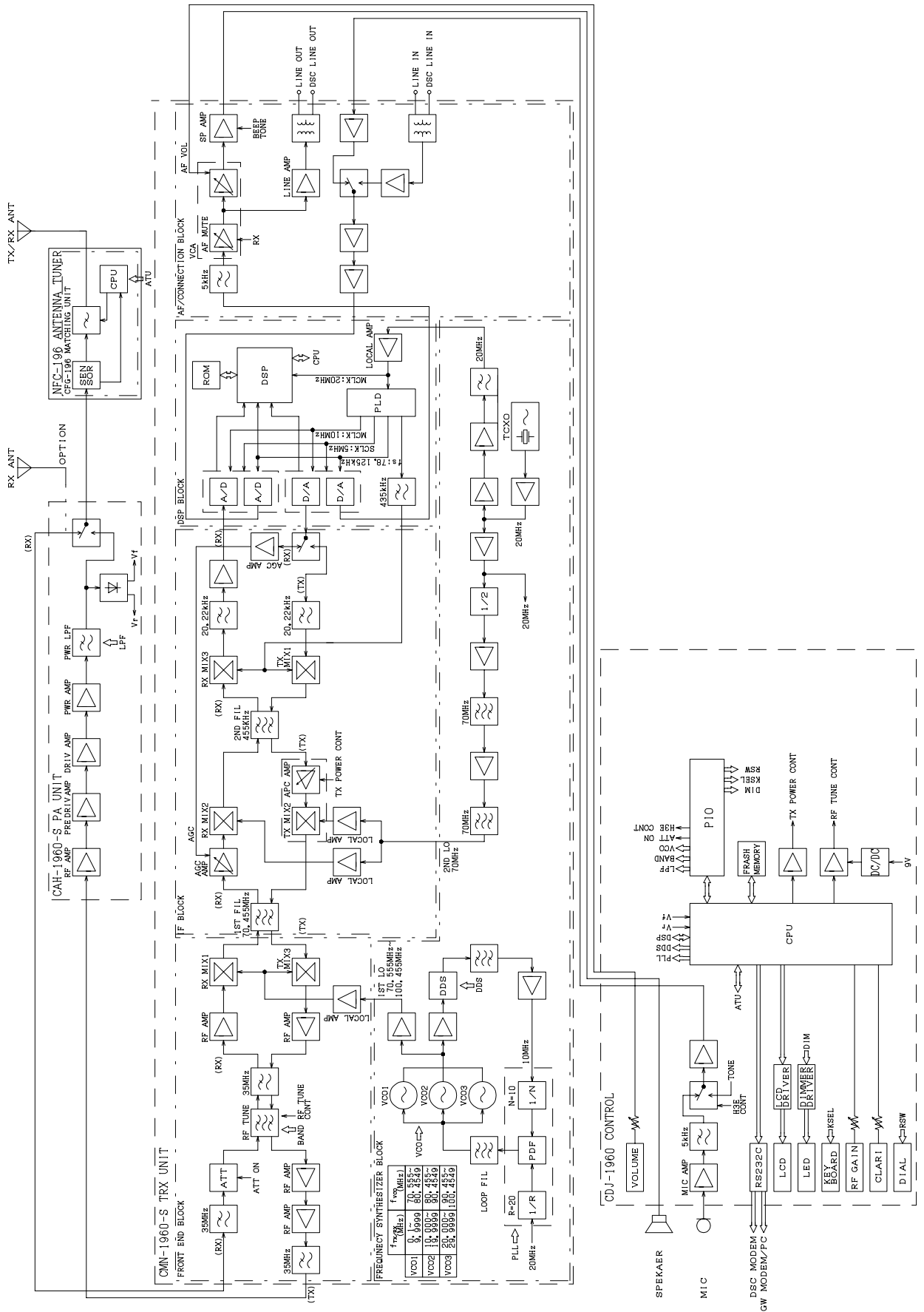

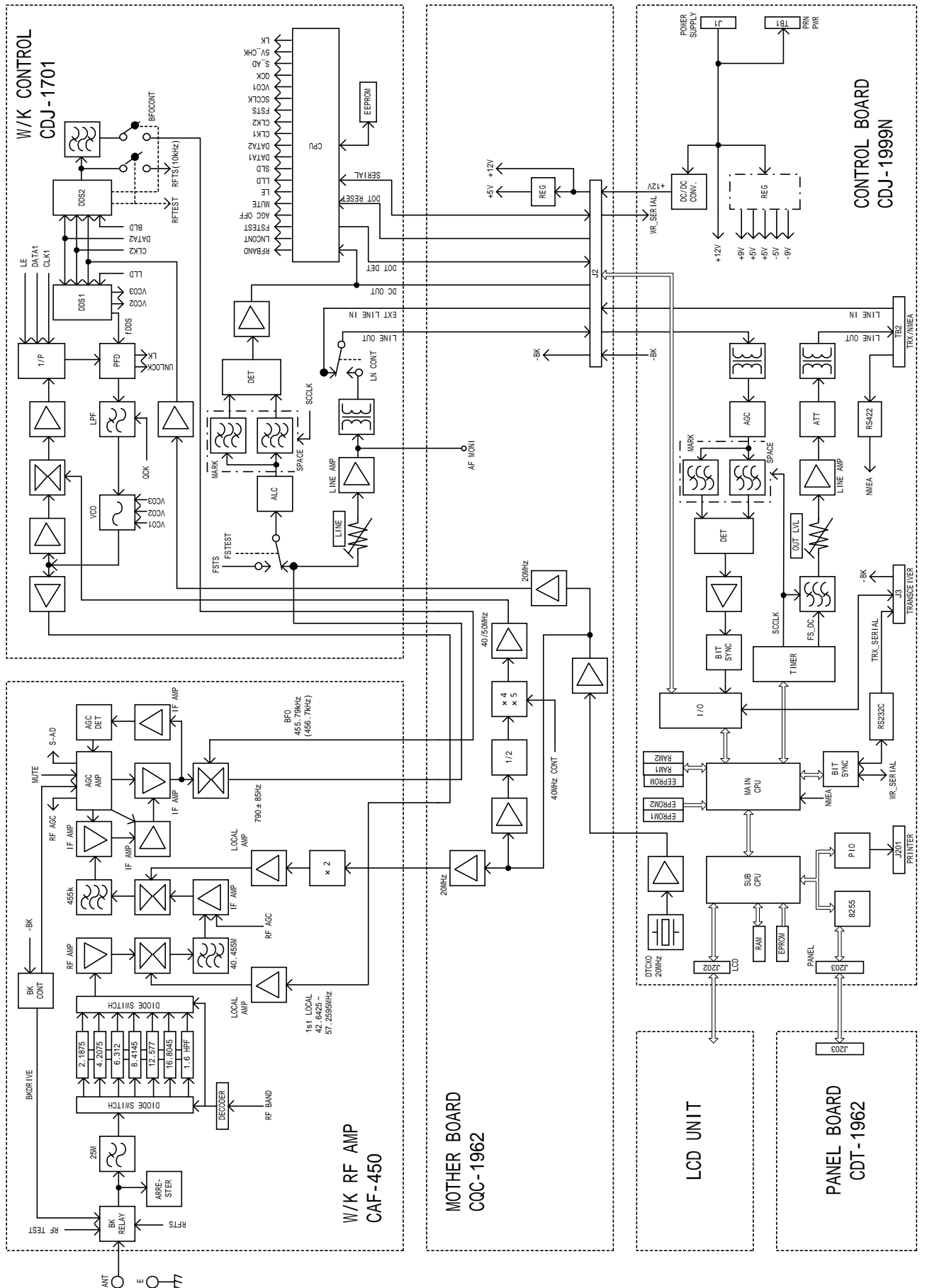

# NAH-692 Power Amplifier

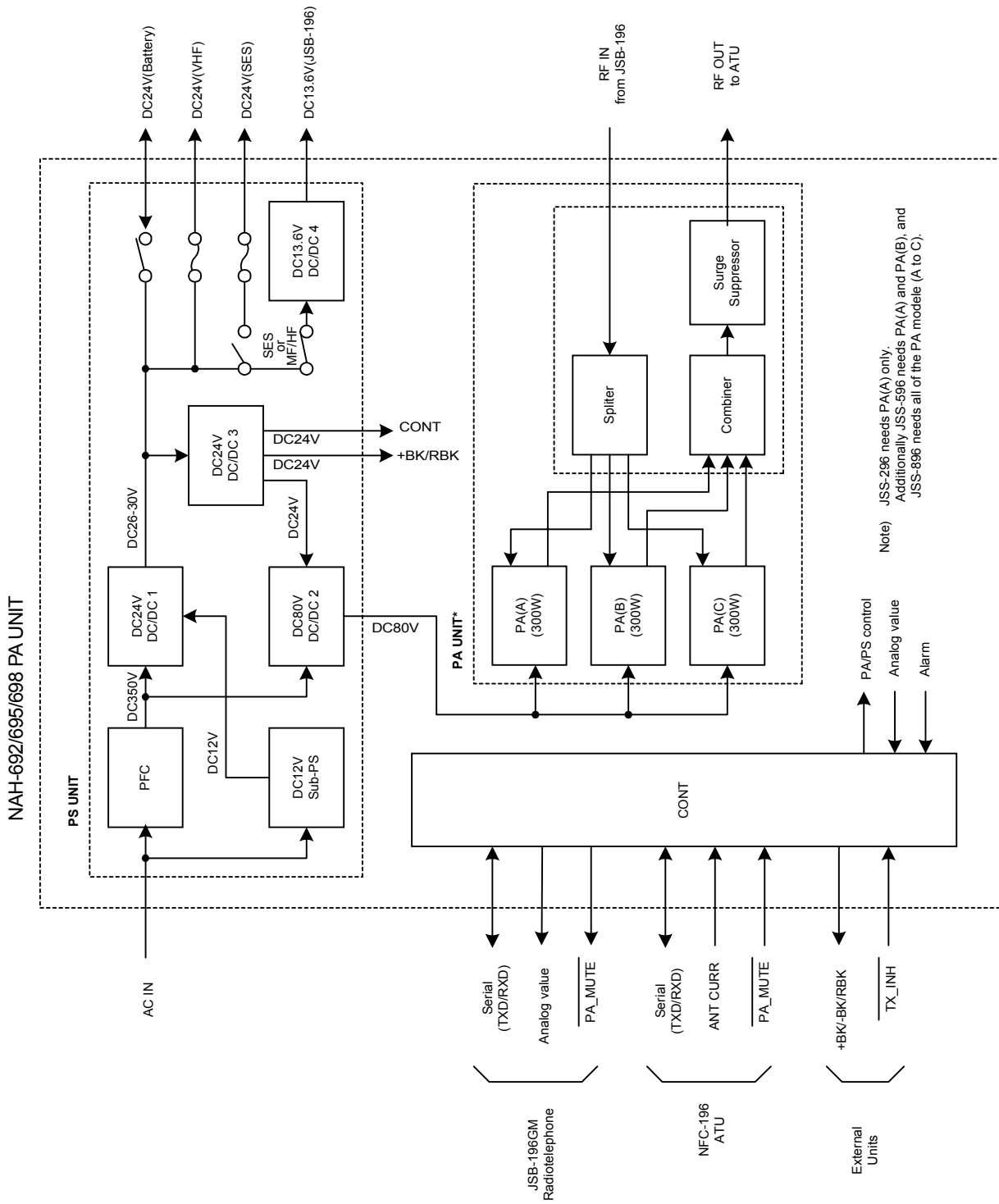

# NFC-296 Antenna Tuning Unit

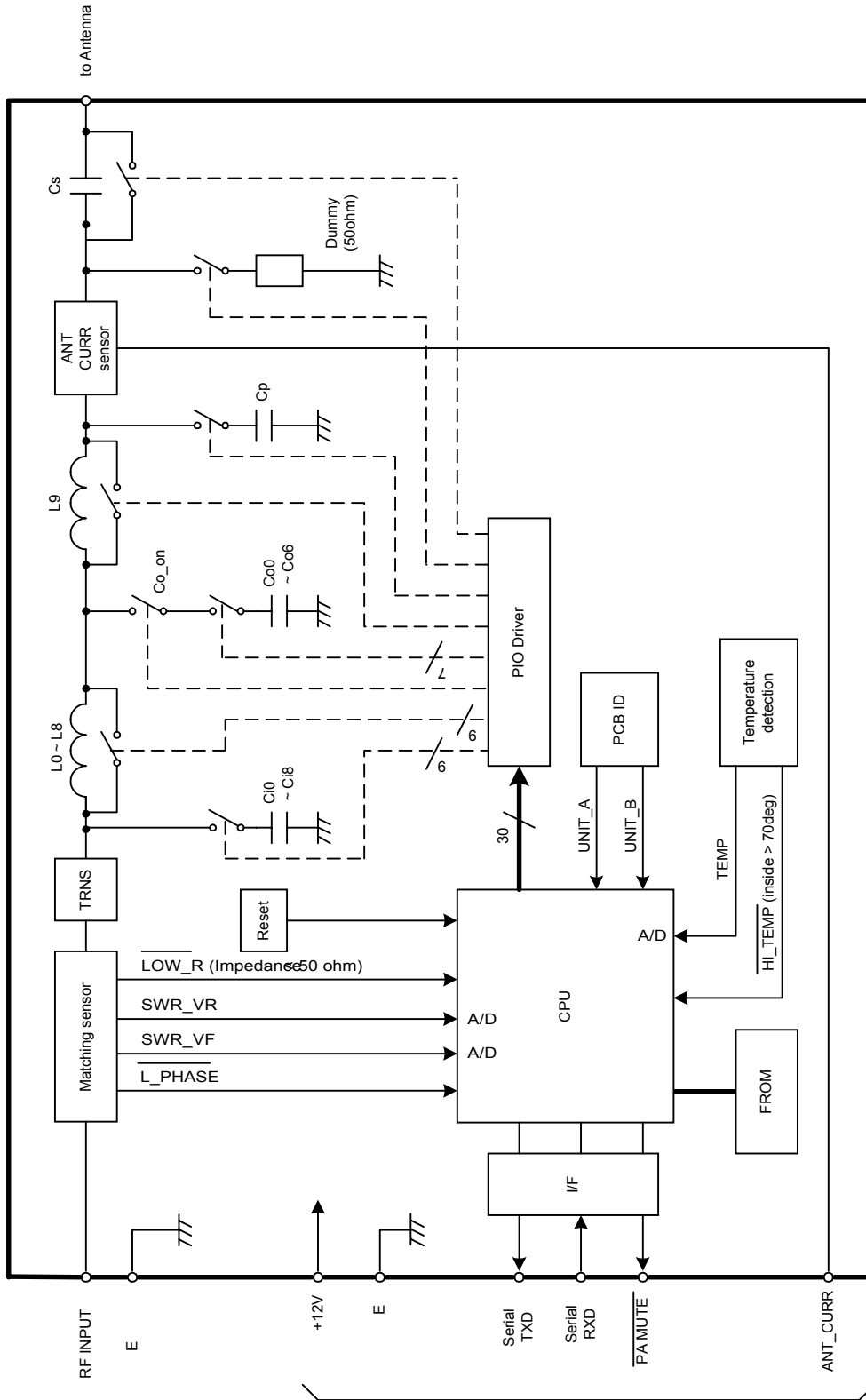

JSB-196GM  
Radiotelephone

## 2. PART NAMES AND FUNCTIONS

### JSB-196GM Radio Equipment

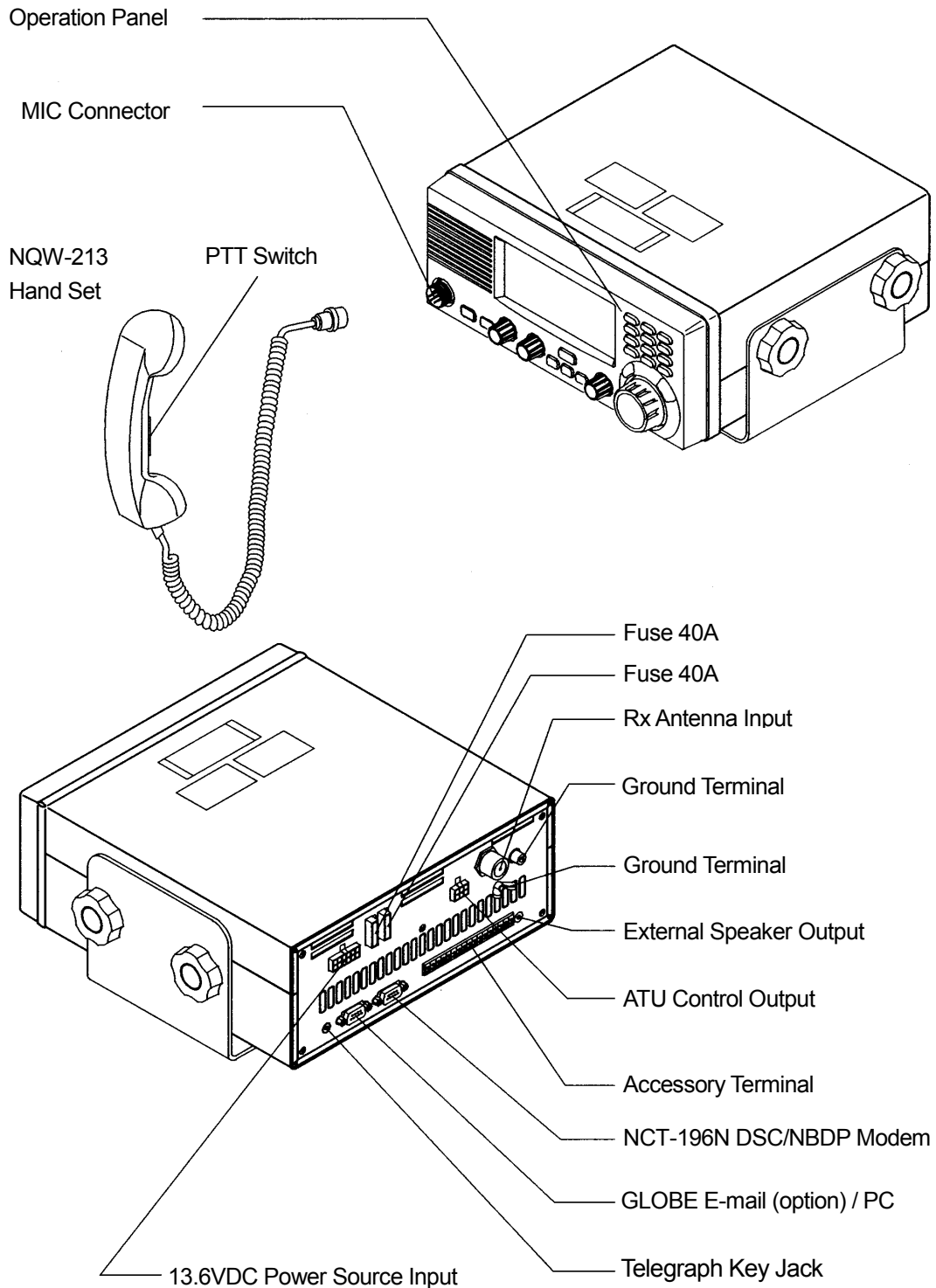

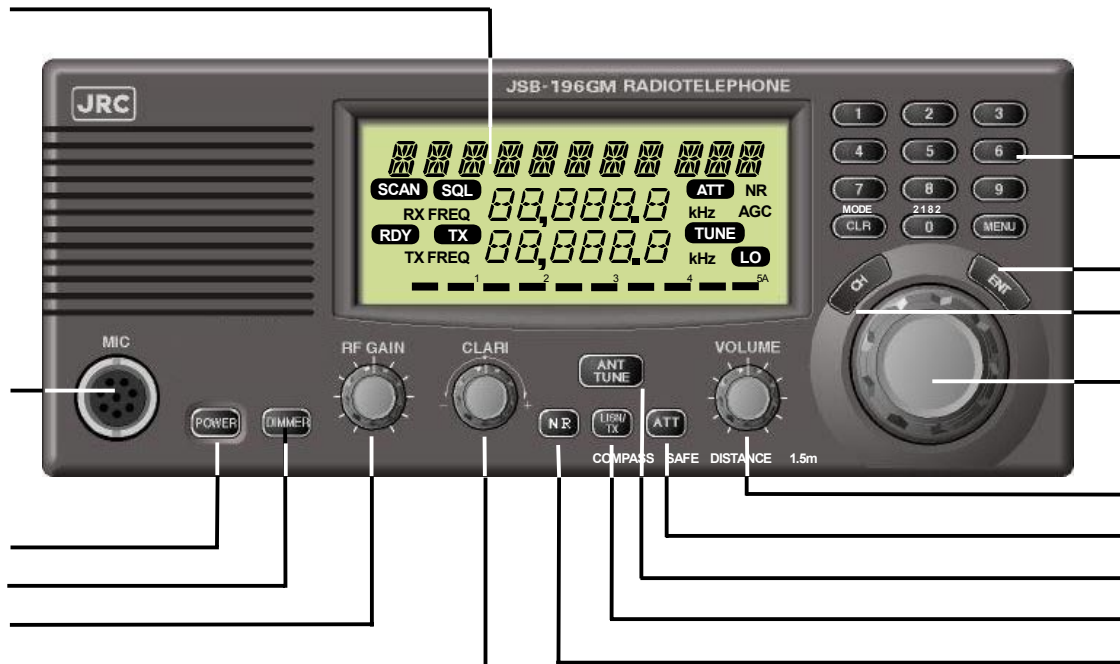

**Liquid Crystal Display Panel**

**MIC**

Connects the hand microphone or handset.

**POWER**

Turns power ON or OFF.

**DIMMER**

Controls the brightness of the LCD.

**RF GAIN**

Controls the RF gain.

**CLARI**

Adjusts the frequency variation, which ranges from -200 to +200Hz in 1Hz steps.

**0 ~ 9 , MENU CLR**

These buttons are used to input frequency/channel values or to set a menu.

**ENT**

Enters the input information.

**CH**

Starts channel selection.

**Jog Dial**

Used to select a channel or receive frequency or to select a menu.

**VOLUME**

Controls the sound volume of reception.

**ATT**

Turns the attenuator ON or OFF.

**ANT TUNE**

Starts antenna tuning.

**LISN TX**

Temporarily monitors the transmission frequency in the Semi-Duplex mode

**NR**

Reduces pulsating noises.

NCT-196N DSC/NBDP Modem

Operation Panel

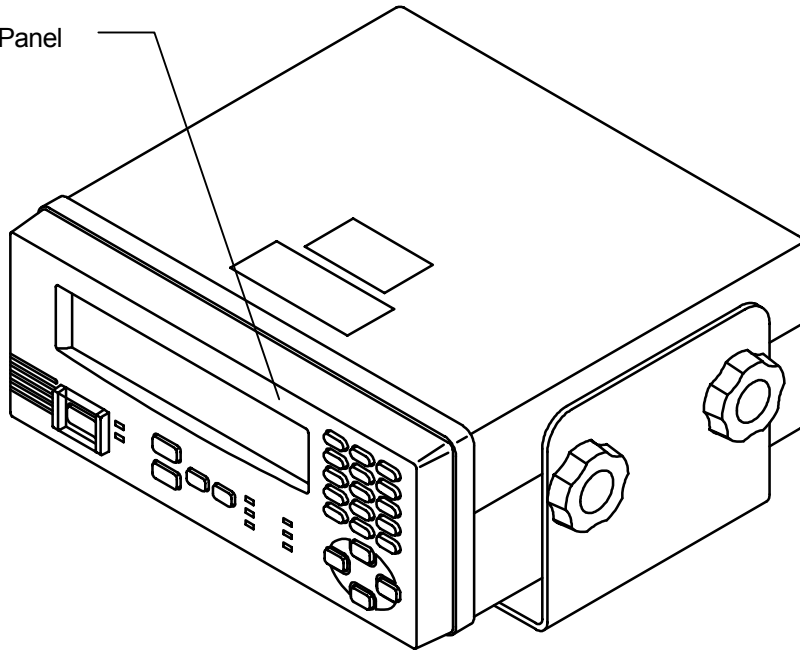

DTE Terminal

Power Switch

Fuse 7.5A

13.6VDC Power Source Input

DMC Terminal

Rx Antenna Input

Ground Terminal

TRX/NMEA Terminal

JSB-196/196GM Terminal

Printer Terminal

Printer

13.6VDC Power Output Terminal

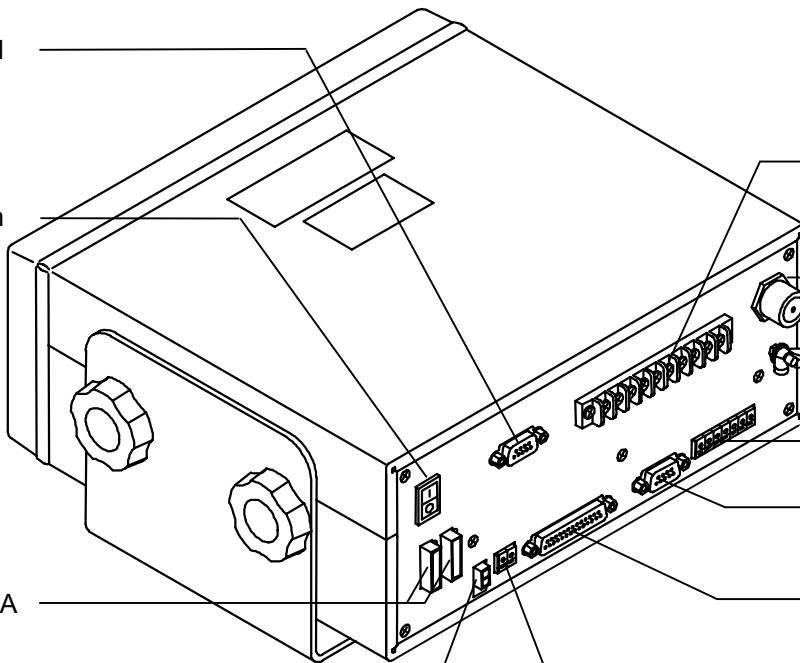



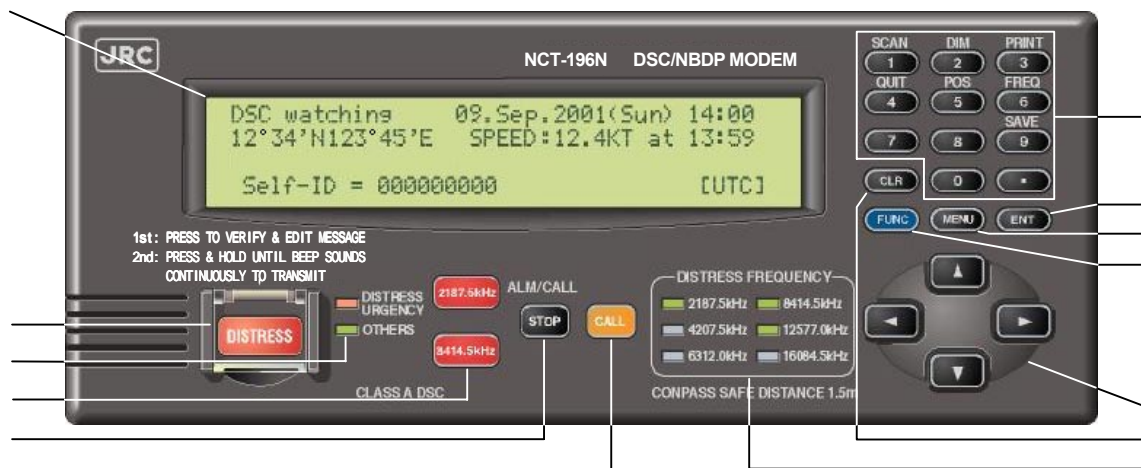

Liquid Crystal Display (LCD) Panel

**DISTRESS**

Sends a distress call.

Transmit/Receive lamp

Red: Lights when a distress or emergency call is being sent or received.

Green: Lights when a normal call is being sent or received.

2187.5kHz , 8414.5kHz

Sets the JSB-196/196GM to the designated frequency and F1B mode.

**STOP**

Stops the call if pressed while a call is being sent. Turns off the alarm lamp and cancels the buzzer if pressed when a call is being received.

If you press this key followed by the **FUNC**, the software version is displayed and the set navigation aid/radio equipment is momentarily displayed. (This is not the initial setting process.)

**CALL**

Press after editing a message to start Transmission of the message.

0 to 9, .

- When editing, these keys enter the indicated numbers.
- If you press the **FUNC** key followed by **1** to **6** and **9**, the following operations are performed:

**1** SCAN: Alternately starts and stops scanning when using the JSB-196/196GM to scan the receive frequencies.

**2** DIM Adjusts the LCD and key brightness in four steps.

**3** PRINT: Prints the current mode operations. In "DSC watching" mode, this key selects "PRINTMENU."

**4** QUIT: Quits editing and returns to the higher mode (MENU, etc.).

**5** POS: When selecting "WORK FREQUENCY" and "POSITION" when editing a message, this key switches to "POSITION".

**6** FREQ: When selecting "WORK FREQUENCY" and "POSITION" when editing a message, this key switches to "WORK FREQUENCY".

**9** SAVE: Saves edited data and returns to the higher mode (MENU, etc.).

**ENT**

Enters key input and selected items.

**MENU**

When pressed in "DSC watching" mode, the screen switches from "MENU#1" to "MENU#2" to "DSC watching", in that order.

**FUNC**

Press this key to select the functions indicated in blue.



Horizontal: Use to selectively display received messages and to select the contents when editing messages.

Vertical: Use to scroll the display and to move the screen pointer vertically.

**CLR**

- Deletes data that has been keyed in.
- Enters the initial value when entering "POSITION" or "WORK FREQUENCY."

Watch-keeping receiver channel  
Lights the channel scanned by the watch-keeping receiver. 2187.5kHz and 8414.5kHz are fixed and cannot be switched.

# NAH-692 Power Amplifier

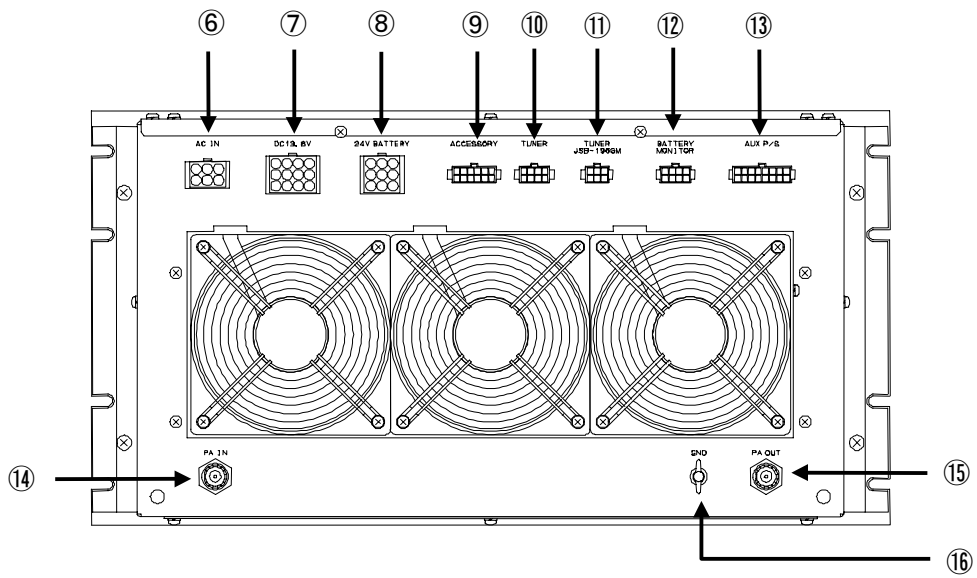
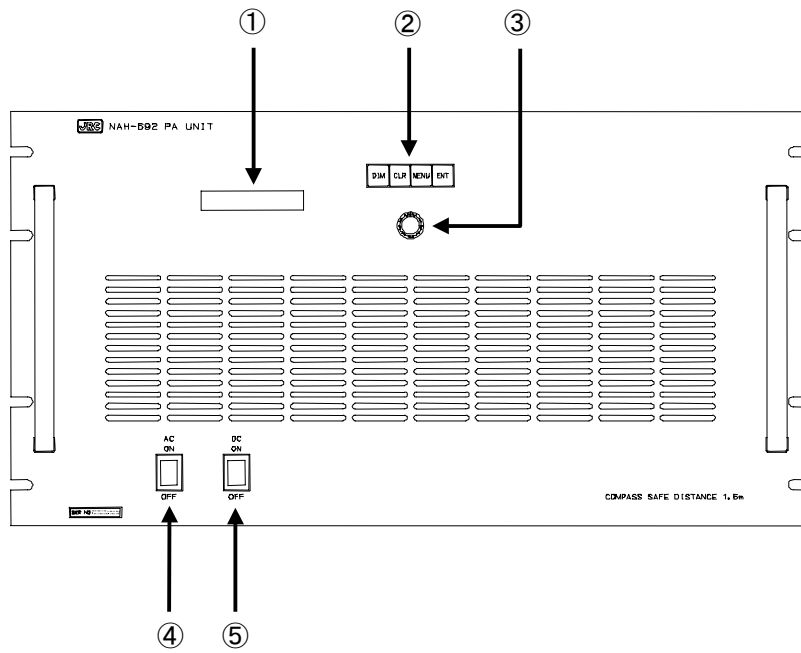

- ① **Liquid Crystal Display (LCD) Panel**  
Display for menu mode or selected meter value
- ② **Menu Buttons**
  - DIM: Dimmer control switch (High/ Medium/ Low)
  - CLR: Clear button for menu selection or alarm sound
  - MENU: MENU mode setting button
  - ENT: Selected menu or parameter entry button
- ③ **Menu Dial**  
Adjust the LCD contrast and select the menu items
- ④ **AC Power Switch**
- ⑤ **DC Power Switch**
- ⑥ **AC IN**  
AC100V~240V mains connector
- ⑦ **DC13.6V**  
DC13.6V power source output connector for JSB-196GM/NCT-196N
- ⑧ **24V BATTERY**  
DC24V power source input connector
- ⑨ **ACCESSORY**  
Peripherals (+/-BK, SES, ANT Changer, etc) control signal connector
- ⑩ **TUNER**  
Tuning control signal connector (to NFC-296 ATU)
- ⑪ **TUNER/JSB-196GM**  
Tuning control signal connector (from JSB-196GM Radiotelephone)
- ⑫ **BATTERY MONITOR**  
Battery and charger status monitor output connector
- ⑬ **AUX P/S**  
DC24V power source output connector (for SES, VHF, etc)
- ⑭ **PA IN**  
RF input connector (from JSB-196GM Radiotelephone)
- ⑮ **PA OUT**  
RF output connector (to NFC-296 ATU)
- ⑯ **GND**



# 3. OPERATIONS

This chapter describes mainly the way to use the JSS-296.

## ATTENTION

Regarding the JSB-196GM Radiotelephone or NCT-196N DSC/NBDP Modem operations in detail, see the specialized instruction manuals for them respectively.

## 3.1 System Standby

### 3.1.1 Turning the Power ON

**1. Turn on the AC and DC switches of NAH-692 Power Amplifier.**

The other components except for JSB-196GM Radiotelephone are turned ON simultaneously. After that the LCD on the front panel of the NAH-692 Power Amplifier shows as follows.

AC Volt	221V
DC Volt	24.2V

**2. Turn on the **POWER** switch of JSB-196GM Radiotelephone. (Note that it is necessary to keep the POWER switch press for 1 sec at least to turn it on.)**

**Note**

Keep the NCT-196N DSC/NBDP Modem power switch turn ON because of the obligation to watchkeep 24 hours a day while at sea.

### 3.1.2 Turning the Power OFF

**1. Turn off the AC and DC switches of NAH-692 Power Amplifier.**

**Note**

The other components including NCT-196N DSC/NBDP Modem are turned OFF simultaneously. Therefore don't turn OFF the switches while at sea because of the obligation to watchkeep 24 hours a day.

## 3.2 MODEM MODE Change

After turning ON the system, according to the mode setting when the system was turned OFF last, the NCT-196N selects the mode. However if needed to change the mode, operate the system in accordance with the following procedure.

### 3.2.1 MODE change to DSC

1. Confirm that the NCT-196N displays the following screen.

```
DSC watching 06.Sep.2001(Thu) 01:26
-----
MODE: XXXX (Press ENT to set DSC mode.)
-----
```

2. Press **ENT** on the panel of the NCT-196N.

#### Note

It is also available to press the keys concerning to Distress (**2187.5kHz** , **8414.5kHz** , or **DISTRESS**) .

3. After the mode change completed, the following initial display appears.

```
DSC watching 06.Sep.2001(Thu) 01:26
12°34'N123°45'E SPEED:12.4KT at 01:26

Self-ID = XXXXXXXXXX [UTC]
```

#### Note

The mode of the peripheral units such as JSB-196/196GM Radiotelephone and NDZ-127J DTE is changed to DSC mode simultaneously by the above-mentioned operation.

### 3.2.2 MODE change to TLX

1. Confirm that the NDZ-127J displays the following screen in any mode except for TLX.

[xxx] Tx=12345.6kHz / Rx=12345.6kHz (ITU CH= 0) 10-APR-2002 12:00(LT)	
Loc: N19.00 E115.30 at 11:00(UTC)	
File Mode Connect	Service System Help
[ STATUS INFO ]	
Scanning info	Tuner/Tx.POWER
[No scanning]	TUNER : [READY]
	Tx.POWER: [FULL]
Last status messages	
Press Enter key to set NBDP mode...	

Move the cursor to the item you want with , , , then press Enter

2. Press **Enter** on the NDF-268 Keyboard.
3. After the mode change completed, the following initial display appears.

[TLX] Tx=12345.6kHz / Rx=12345.6kHz (ITU CH= 0) 10-APR-2002 12:00(LT)	
Loc: N19.00 E115.30 at 11:00(UTC)	
<b>File</b> Mode Connect	Service System Help
[ STATUS INFO ]	
<b>ST-BY</b>	
Scanning info	Tuner/Tx.POWER
[No scanning]	TUNER : [READY]
	Tx.POWER: [FULL]
Last status messages	

Move the cursor to the item you want with , , , then press Enter

**Note**

The mode of the peripheral units such as JSB-196/196GM and NCT-196N is changed to TLX mode simultaneously by the above-mentioned operation.

## 3.3 Setting Position and Time Data

### ATTENTION

If the position and time data from navigation aids such as a GPS receiver stop for more than 5 minutes, or if it past for more than 4 hours without further input after entering position and time data manually, the NCT-196N sounds alarm. When the alarm sounding in condition of navigation aid connecting, check the navigation aid or the connections to the NCT-196N. Or when the alarm sounding in condition of no navigation aid connecting, enter the new position and time data manually.

### 3.3.1 Setting the Internal Clock(DATE & TIME EDIT)

The built-in clock of the NCT-196N can be set the date (year, month, and day) and time manually. However if the NCT-196N is connected to a navigation aid, the manual input data is overwritten because the navigation aid has priority over the NCT-196N internal clock. The standard time is UTC but it is possible to input time difference from the UTC and display the current local time (LT). Note that in case of no navigation aid connecting, time data should be set to the present time manually and periodically because the time data input manually is treated as invalid data and deleted after 23.5 hours past.

#### Procedure

#### 1. Check that the "DSC watching" screen is displayed.

```
DSC watching 06.Sep.2001(Thu) 01:26 P
12°34'N123°45'E SPEED:12.4KT at 01:26

Self-ID = XXXXXXXXXX [UTC]
```

#### Note

If the "DSC watching" screen is not displayed, press **STOP** 3 times in succession to switch to the "DSC watching" screen.  
On the screen **P** mark is displayed when no printer is connected to the NCT-196N.

#### 2. Press **MENU**.

The "MENU#1-EDIT&CALL" screen is displayed.

```
MENU #1-EDIT&CALL      Select no._
▶ 1.Individual call
  2.Acknowledgement call
  3.Distress call
  4.Distress relay call
  5.Auto/semi-auto call
  6.All ships call
  7.Group call
  8.Area call
  9.Position request
 10.Polling call
 11.Test call
```

Use  and  to scroll.



**3. Press **MENU** again.**

The "MENU#2-READOUT&SETUP" screen is displayed.

```
MENU #2 -READOUT&SETUP   Select no._
▶ 1.Received distress message readout
  2.Received others message readout
  3.Setup
  4.Self test
```

Use  and  to scroll.

**4. Press **3** , and then press **ENT** .**

The "SETUP" screen is displayed.

```
SETUP                     Select no._
▶ 1.Date&time edit
  2.Position edit
  3.Calling frequency registration
  4.Address registration
  5.Distress setup
  6.Others alarm setup
  7.Automatic acknowledgement setup
  8.Scanning setup
  9.Watchkeeping receiver setup
```

Use  and  to scroll.

**5. From the "SETUP" screen, press **1** , and then press **ENT** .**

The "DATE&TIME EDIT" screen is displayed.

```
DATE&TIME EDIT
▶ Date (dd:mm:yy):06.05.00
  Time (hh:mm)   :19:23
  Time difference:-05:00
  Display time   :UTC
```

Use  and  to scroll.

**6. Enter the respective settings.**

- When the display time is set to "LT", enter the difference to the UTC in the "Time difference" item.
- Use the cursor keys ( and ) to switch between "+/-" for the "Time difference" and between "UTC/LT" for the "Display time".

**7. On completion of entering the data, press **FUNC** , and then press **9** (SAVE).**

Operation returns to the "SETUP" screen.

**Note**

If you press **FUNC** , and then press **4** (QUIT), the settings are discarded.

### 3.3.2 Specifying Position Input (POSITION EDIT)

This operation enters the ship's position data manually. However if the NCT-196N is connected to a navigation aid, which inputs the date and time data, the data from the navigation aid overwrite this position data input manually because the navigation aid has priority over the NCT-196N. The position data is used in the distress file when pressing the DISTRESS button, in the automatic acknowledgement files and as the initial value when editing messages. For the "SETUP" screen, please see Section 3.3.1, " Setting the Internal Clock (DATE&TIME EDIT)", steps 1 to 4. Note that in case of no navigation aid connecting, the position data should be set manually and periodically because it is treated as invalid and deleted after 23.5 hours past.

#### Procedure

1. From the "SETUP" screen, press **2** and then press **ENT** .  
The "POSITION EDIT" screen is displayed.

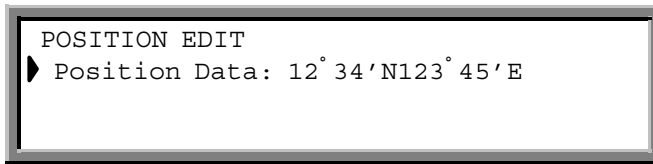

2. Enter the ship's position.

• Use the cursor keys ( **◀** and **▶** ) to switch between "NE", "NW", "SE", and "SW".

3. On completion of entering the data, press **FUNC** , and then press **9** (SAVE).  
Operation returns to the "SETUP" screen.

**Note** If you press **FUNC** , and then press **4** (QUIT), the settings are discarded.

## 3.4 Radiotelephone operations

### 3.4.1 Turning the Power ON / OFF

# ⚠ CAUTION



Never touch the antenna terminal, grounding terminal or counterpoise when the JSB-196GM is turned ON. Doing so, may cause electrical shock.



Place Antenna Tuner NFC-196, antenna and counterpoise in position where no one touches them. Doing not so, may cause electrical shock.

#### 3.4.1.1 Turning the Power ON

Press **POWER** on the front panel until the channel and frequencies are displayed as follows:

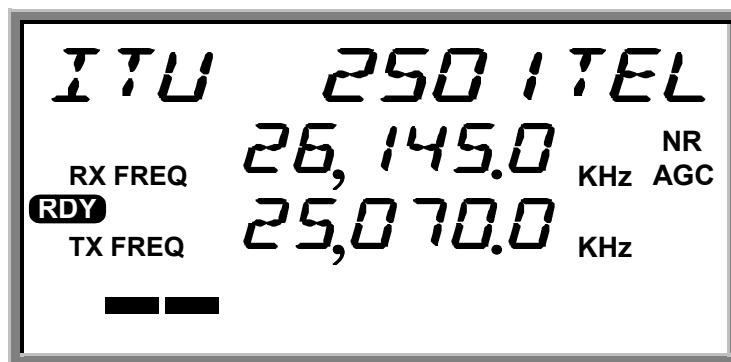

Figure 5.1 Initial display on the LCD (immediately after the equipment is powered on)

#### 3.4.1.2 Turning the Power OFF

Press **POWER** until LCD disappears.

#### Note

The latest frequency and set-up state information such as communication mode are stored in memory when the equipment is turned OFF. It will be set automatically when the equipment is powered on again except the following items and these items will be set to as follows:

- Built-in loudspeaker ON/OFF (ON as default)
- Squelch value (0 as default)

### 3.4.2 Communication Procedure

The JSB-196GM employs the Jog Dial for simply setting or selection for principal functions such as TX/RX frequency, communication mode, output power, squelch, AGC, etc. and the following procedures are provided for pleasant communication.

#### 3.4.2.1 Setting the channel number with the Jog Dial

User channels can be set with the Jog Dial.

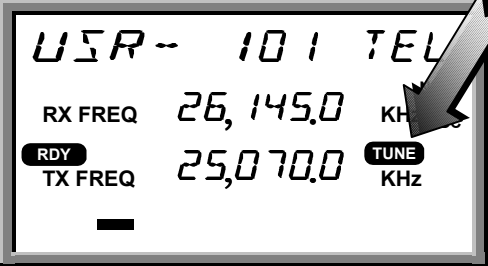
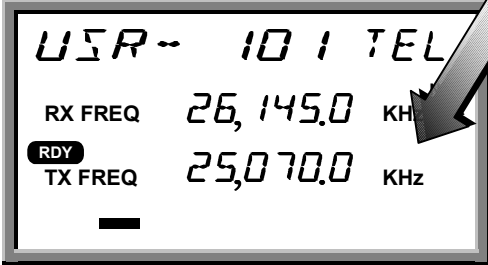
Procedure	Examples of display on the LCD
<p>Example of user channel number 101</p> <ol style="list-style-type: none"><li>1. Press <input type="button" value="CH"/> . Group number appears in the channel field of the LCD.</li><li>2. Turn the Jog Dial. (*1) Turn the Jog Dial until the group number, ex. "GROUP 6 TEL", including the objective channel number is displayed.</li><li>3. Press <input type="button" value="ENT"/> . User channel number is displayed.</li><li>4. Turn the Jog Dial again until the objective number, "USR-101" is displayed and complete setting.  If <input type="button" value="TUNE"/> is blinking, press <input type="button" value="ANT TUNE"/> . <input type="button" value="TUNE"/> lights steadily during tuning, and disappear when tuning is completed.</li><li>5. With these steps, the JSB-196GM is ready to communicate. Start communication by pressing PTT on the hand set.</li></ol>	<p>(in the TEL mode)</p> <p><input type="text" value="GROUP 1 TEL"/></p> <p><input type="text" value="GROUP 6 TEL"/></p> <p><input type="text" value="USR-101 TEL"/></p>  

**Note** For easy selection of a channel number, you can allocate an identification label to each channel (See "5.3.6 Registering a user channel").

### 3.4.2.2 Monitoring the transmission frequency

In semi-duplex mode the TX/RX frequency are set differently, though only one way transmission or reception is possible at the same time. The transmission frequency signal can be checked for interference.

#### Procedure

1. Press **LISN/TX**.

JSB-196 starts to receive TX frequency. After the check, press **LISN/TX** again or transmit to return to the initial state.

### 3.4.2.3 Setting the channel number with keypad

User channel number can be set with keypad as follows.

#### Procedure

Example of user channel number 101 (RX frequency 26145.0 kHz / TX frequency 25070.0 kHz).

1. Press **CH**.

"GROUP 1 TEL" appears in the channel field of the LCD.

2. Press **1**, **0** and **1**.

The channel number is displayed in the channel field of the LCD.

#### Note

User channel number: 1 to 200  
 ITU channel number:  
 TEL: 401 to 2517 CW: 401 to 2524  
 TLX: 401 to 2571 DSC: 401 to 2503

3. Press **ENT**.

The input channel number is fixed.

4. Input the RX/TX frequency.

See the 4.3.3.6 Registering the user channel step 4 ~ 7.

5. If **TUNE** is blinking, press **ANT TUNE**.

**TUNE** lights steadily during tuning, and disappear when tuning is completed.

6. With these steps, the JSB-196GM is ready to communicate. Start communication by pressing PTT on the Hand set.

#### Examples of display on the LCD

(in the TEL mode)

GROUP 1 TEL

CH- 101 TEL

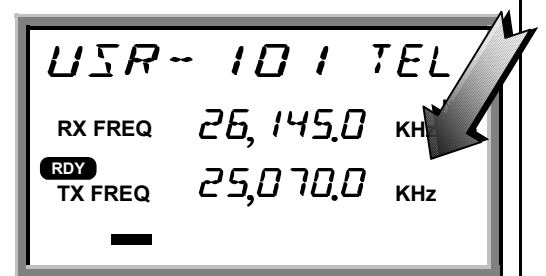
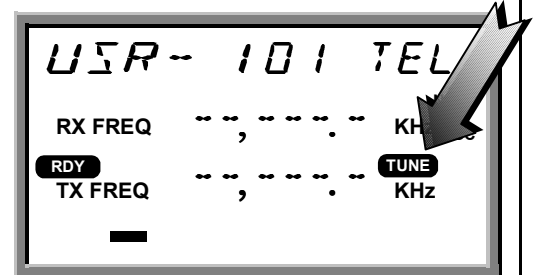

#### Note

At channel setting, current mode must not be DSC mode.

### 3.4.2.4 Manually inputting frequency

In this case, communication mode must be set in advance (For setting of a radio mode, see "5.3.1 setting a communication mode"). TX and RX frequency can be set with keypad as follows.

#### Procedure

Example of RX frequency 4357.0 kHz / TX frequency 4065.0 kHz .

1. Press **4**, **3**, **5**, **7** and **0** for the RX frequency. The RX frequency is displayed in the channel field of the LCD.

2. Press **ENT** .

The RX frequency is fixed. When you want to use this frequency also as a TX frequency, press **ENT** again.

3. Press **4**, **0**, **6**, **5** and **0** for the TX frequency. The TX frequency is displayed in the channel field of the LCD.

4. Press **ENT** .

The TX frequency is fixed.

5. If **TUNE** is blinking, press **ANT TUNE** .

**TUNE** lights steadily during tuning, and disappear when tuning is complete.

6. With these steps, the JSB-196GM is ready to communicate. Start communication by pressing PTT on the Hand set.

#### Examples of display on the LCD

(in the TEL mode)

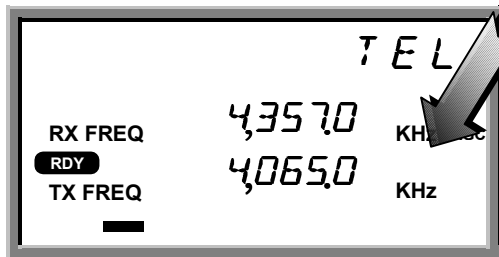
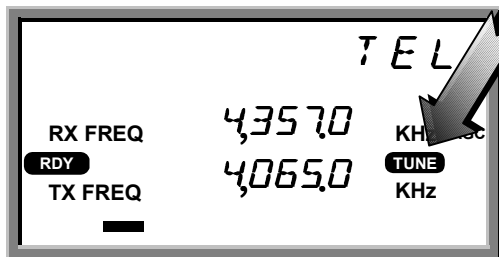
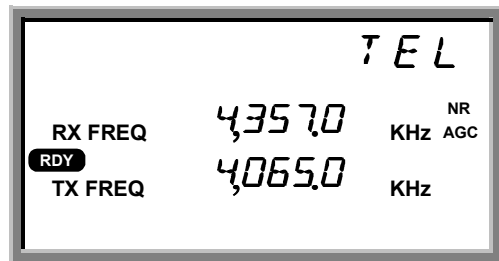
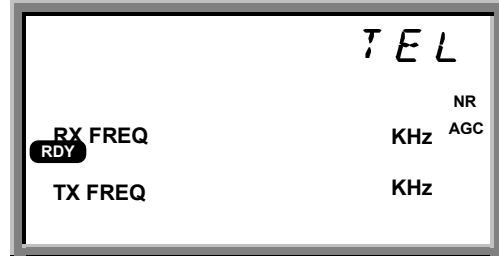

#### Note

- Press two or three times **CH** , enable to change the RX/TX frequency individually.
- Press **0** to change the DISTRESS frequency 2,182.0 kHz.

### 3.4.2.5 Scanning reception

The reception frequency stored in user channel group 1 to 10, each 20 channels can be scanned. You can select a desired group (20 user channels per group) for scanning.

#### Procedure

Example of group 7.

1. Press **MENU**, then turn the Jog Dial until "SCAN" appears in the channel field of the LCD.
2. Press **ENT**.  
"Group 1 1" appears in the channel field of the LCD.
3. Turn the Jog Dial until objective group is displayed.
4. Press **ENT**.  
Scanning reception starts.  
**SCAN** appears on the center left of the LCD.  
The group name and number which are scanned are displayed in the channel field of the LCD.
5. To cancel scanning, press **CLR**. The last communication mode and the frequencies are set.

#### Examples of display on the LCD

(in the TEL mode)

MODE TEL

SCAN 5

GROUP 1 1

GROUP 7 7



### 3.4.3 Other Function Settings

The function setting is basically executed by using **MENU** key and the Jog Dial, and the settable items blinks and is set with **ENT** key.

#### 3.4.3.1 Setting the communication mode

In the use of manually inputting frequency, communication mode must be set in advance.

#### Procedure

Example of CW.

1. Press **MENU**.

"MODE" in the channel field of the LCD blinks.

2. Press **ENT**.

The current communication mode "TEL" blinks.

3. Turn the Jog Dial.

Turn the Jog Dial until objective mode. "CW" is blinking.

4. Press **ENT**.

CW is fixed as communication mode.

5. If **TUNE** is blinking, press **ANT TUNE**.

**TUNE** lights steadily during tuning. And disappear when tuning is complete.

#### Examples of display on the LCD

(in the TEL mode)

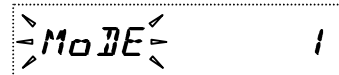

MODE 1

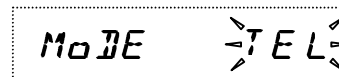

MODE TEL

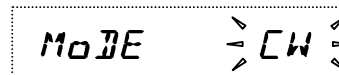

MODE CW



CW  
RX FREQ 26,145.0 KHz AGC  
RDY TX FREQ 25,070.0 KHz  
TUNE



CW  
RX FREQ 26,145.0 KHz AGC  
RDY TX FREQ 25,070.0 KHz  
TUNE

**Note** • Press **CLR** to change the communication mode successively.



### 3.4.3.2 Setting the output power

The output power can be set to "HI (150W)" or "LOW (50W)".

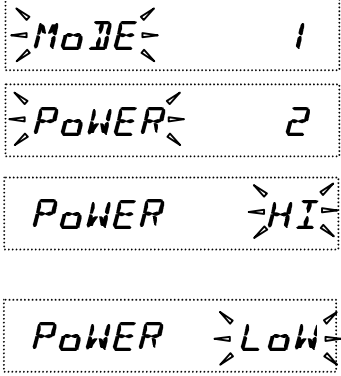
Procedure	Examples of display on the LCD
<ol style="list-style-type: none"><li>1. Press <b>MENU</b> ,then turn the Jog Dial until "Power" in the channel field of the LCD blinks.</li><li>2. Press <b>ENT</b> . The current out power "HI" blinks.</li><li>3. Turn the Jog Dial until "LOW " blinks.</li><li>4. Press <b>ENT</b> . The output power is set to "LOW ". <b>LO</b> on the lower right corner of the LCD turns on.</li></ol>	

### 3.4.3.3 Turning the Automatic Gain Control (AGC) ON

The AGC circuit functions to maintain a constant receiver output by automatically adjusting the gain according to the strength of the reception signals.

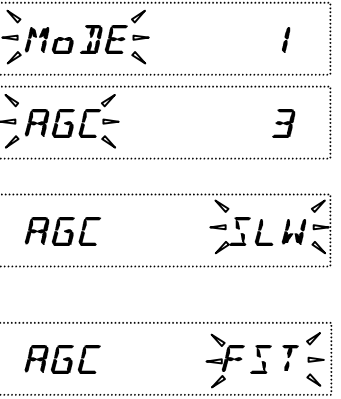
Procedure	Examples of display on the LCD
<ol style="list-style-type: none"><li>1. Press <b>MENU</b> , then turn the Jog Dial until "AGC" in the channel field blinks.</li><li>2. Press <b>ENT</b> . The current AGC status "SLW" blinks.</li><li>3. Turn the Jog Dial until desirable state "FST" or "OFF" appears.</li><li>4. Press <b>ENT</b> . The desirable "AGC" state is fixed. "AGC" turn on the right corner of the LCD when you set to "SLW" or "FST".</li></ol>	

**Note**

In "TLX" mode, "AGC" state is fixed to "FST". (You can not set to "SLW".)

### 3.4.3.4 Adjusting squelch level

The squelch circuit functions to mute received signals based on its level. The larger the squelch level, the larger the antenna input level is required to open the squelch circuit. When the squelch circuit is activated (mute status), **SQL** in the LCD turns on.

#### Procedure

1. Press **MENU** , then turn the Jog Dial until "SQUELCH" blinks.
2. Press **ENT** .  
The current squelch level "0" blinks.
3. Turn the Jog Dial until desired squelch level appears. When turn the Jog Dial, the bar on the bottom of the LCD expands to indicate the squelch level.
4. Press **ENT** .  
The squelch level is fixed.

#### Examples of display on the LCD

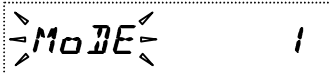

MODE 1



SQUELCH 4



SQUELCH 0



SQUELCH 6

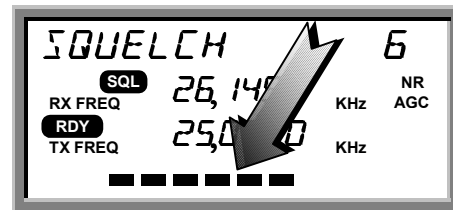

### 3.4.3.5 Setting the scanning speed

The scanning time for each channel is settable between 0.3 to 5 seconds.(multiple of 0.1 second)

#### Procedure

Example of 0.3 seconds.

1. Press **MENU** , then turn the Jog Dial until "SCAN SPD" blinks.  
  
2. Press **ENT** .  
  
The current value "10" blinks.
3. Turn the Jog Dial until desirable scanning time appears or manually input the value from keypad.
4. Press **ENT** .  
  
The scanning time is fixed to 0.3 seconds.

#### Examples of display on the LCD



MODE 1

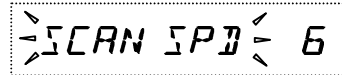

SCAN SPD 6

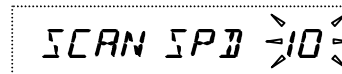

SCAN SPD 10

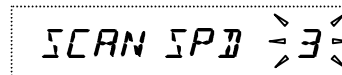

SCAN SPD 3

### 3.4.3.6 Registering the user channel

You use frequently can be registered as a user channel up to 200, channel number 1 to 200.

#### Procedure

Example of registration for RX frequency 4357.0 kHz / TX frequency 4065.0 kHz, communication mode is TEL, Channel Label Registration is MITAKA1 at the user channel number 1.

1. Make sure that a objective communication mode is set and press **MENU** and then turn the Jog Dial until "USR MEMO" blinks.
2. Press **ENT** .  
  
Select the user channel number with the Jog Dial or keypad.
3. Press **ENT** .  
  
Select the communication mode with the Jog Dial<sup>(\*)</sup>.

#### Examples of display on the LCD

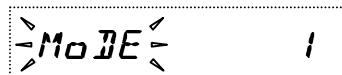

MODE 1



USR MEMO 7



USR 001 1



USR 001 TEL

## Procedure

4. Press  .  
Press , , ,  and  for the RX frequency. The RX frequency is displayed in the channel field of the LCD.
5. Press  .  
The RX frequency is fixed<sup>(\*)2</sup>.
6. Press , , ,  and  for the TX frequency. The TX frequency is displayed in the channel field of the LCD.
7. Press  .  
The TX frequency is fixed.
8. Select an alphabet or number(MITAKA1) with the Jog Dial. Input decision or "SPACE" key is  .  
After selection, press , and fix to press  <sup>(\*)3</sup>.
9. The Channel Label Registration mode is set. If you want to complete the inputting user channel, two times  .

## Examples of display on the LCD

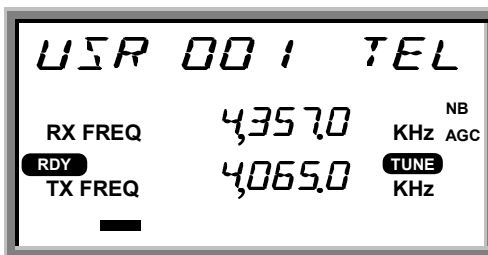
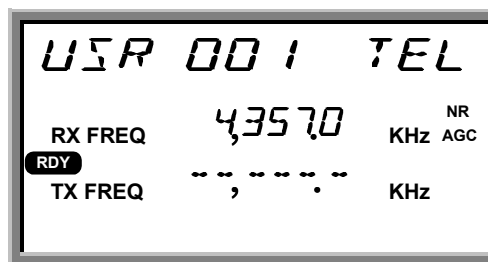

### Note

- \*1 When correct the registered channel, press  , then select the collection item as follows:  
In case of change the communication mode or clear the channel, turn the Jog Dial. Then press  .  
In case of change the RX or TX frequency or the channel Label, press  successively and input the new parameter.
- \*2 In step 2, the frequency can be inputted manually. RX frequency and a TX frequency in this order and go to step 8 (When you want to use an identical frequency for reception and transmission, press  only after inputting RX frequency).
- \*3 In step 7, you do not need the label, press  and go to step 9.

### 3.4.3.7 Registering a channel group name

200 user channels are grouped into 10 groups, each 20 channels. These groups are used for scanning reception, and can be named for quick selection.

#### Procedure

1. Press **MENU** , then turn the Jog Dial until "GRP MEMO" blinks.
2. Press **ENT** .  
A group number "1" blinks in the right end of the channel field of the LCD.
3. Turn the Jog Dial until the objective group appears.
4. Press **ENT** .  
" \_ " blinks.
5. Repeat to select an alphabet or number with the Jog Dial, and press **ENT** eight times.
6. Channel group number is fixed.

#### Examples of display on the LCD

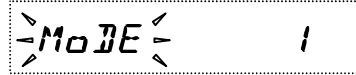

MODE 1



GRP MEMO 8

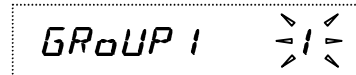

GROUP 1

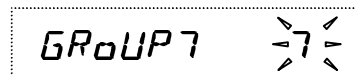

GROUP 7



\_ 7

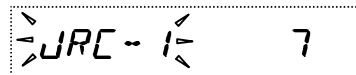

JRC-1 7

### 3.4.3.8 Setting the meter indication mode

The bar indicator on the bottom of the LCD indicates signal level during reception or output during transmission, furthermore output indication is settable to the output power mode or antenna current mode.

#### Procedure

1. Press **MENU** , then turn the Jog Dial until "METER" blinks .
2. Press **ENT** .  
"PWR" blinks.
3. Turn the Jog Dial until desired mode appears.  
"PWR" : Indication for output power.  
"ANT" : Indication for antenna current.
4. Press **ENT** .  
Indication mode, "PWR" or "ANT", is fixed.

#### Examples of display on the LCD

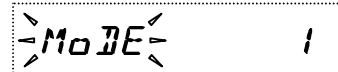

MODE 1

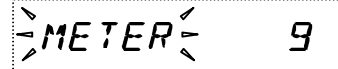

METER 9

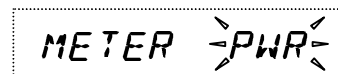

METER PWR

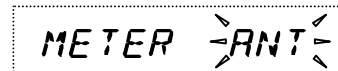

METER ANT

### 3.4.3.9 Setting the Automatic Tuning Start (ATS)

The ATS function is used for pre-tuning at change of channel / frequency, and tuning starts automatically when the standing-wave ratio (SWR) is wrong.

#### Procedure

1. Press **MENU** , then turn the Jog Dial until "ATS" blinks.
2. Press **ENT** .  
"OFF" blinks.
3. Turn the Jog Dial to set "ON" or "OFF".
4. Press **ENT** .  
The ATS function is turned "ON" or "OFF" .

#### Examples of display on the LCD

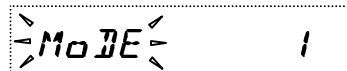

MODE 1

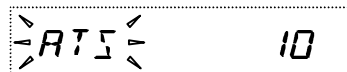

ATS 10

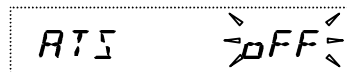

ATS OFF

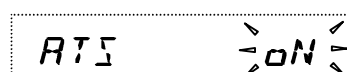

ATS ON

### 3.4.3.10 Setting the wait time for ATS

On the ATS function, wait time for tuning start after change of channel / frequency is adjustable.

#### Procedure

1. Press **MENU** , then turn the Jog Dial until "ATS WAIT" blinks.
2. Press **ENT** .  
"3" blinks.
3. Turn the Jog Dial to select the time or manually input the time with keypad.
4. Press **ENT** .  
The wait time is fixed.

#### Examples of display on the LCD

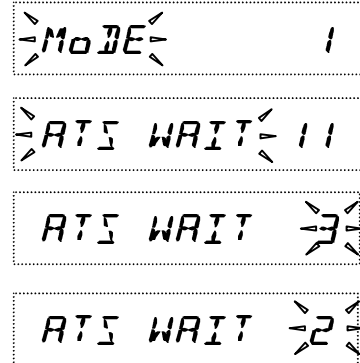

### 3.4.3.11 Turning the key-in sounds ON / OFF

The key-in sounds are available for keypad operation.

#### Procedure

1. Press **MENU** , then turn the Jog Dial until "BEEP" blinks.
2. Press **ENT** .  
"BEEP" lights steadily and "ON" blinks.
3. Turn the Jog Dial to select "ON" or "OFF".
4. Press **ENT** .  
The key-in sounds are turned "ON" or "OFF".

#### Examples of display on the LCD



#### Note

The key-in sounds are suspended, when set the loudspeaker OFF.

### 3.4.3.12 Setting the loudspeaker output ON / OFF

The loudspeaker output can be turned OFF.

#### Procedure

1. Press **MENU** , then turn the Jog Dial until "SPEAKER" blinks.
2. Press **ENT** .  
"SPEAKER" lights steadily and "ON" blinks.
3. Turn the Jog Dial to select "ON" or "OFF".
4. Press **ENT** .  
The loudspeaker output is turned "ON" or "OFF".

#### Examples of display on the LCD

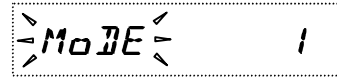

MODE 1



SPEAKER 13



SPEAKER ON



SPEAKER OFF



### 3.4.3.13 List of shortcut keys

The following shortcut keys are provided for easy selection of menu items.

Using a shortcut key: The expression "1. Press  , then turn the Jog Dial" in the above procedure steps can be substituted by " Press  and input its shortcut key number with keypad".

Menu item	Shortcut key number	Function
MODE	1	Select the communication mode. TEL (J3E), DSC (F1B), TLX (F1B), CW (A1A), AME (H3E)
POWER	2	Set the output power to low (50 watts).
AGC	3	Select the AGC (Auto Gain Control) function.
SQUELCH	4	Adjust the squelch level.
SCAN	5	Enable the scanning function.
SCAN SPD	6	Set the scanning time.
USR MEMO	7	Register the user channel.
GRP MEMO	8	Register the channel group name.
METER	9	Select the bar-meter function. ANT: antenna current, PWR: output power.
ATS	10	Enable the ATS (Automatic Tuning Start) function.
ATS WAIT	11	Set the wait time for the ATS function.
BEEP	12	Disable the key-in sound panel.
SPEAKER	13	Disable the output of the built-in loudspeaker.
CHECK	14	Perform the Self Diagnosis function.
VERSION	15	Display the firm-ware version on Control unit CDJ-1960, DSP, Antenna Tuner and Power Amplifier.

**Note**

In JSS-296, Control unit's version must be 2.00 or later.



## 3.5 DSC operations

This section describes menus and modes (Section 3.5.1), receiving DSC calls (Section 3.5.2), and making DSC calls (Section 3.5.3). Section 3.5.4 describes how to store the calling frequencies used with the DSC, and the setting of destination IDs, etc.

### 3.5.1 Menus and Modes

#### (1) Menu Hierarchy

The menus displayed on the screen have the following hierarchical structure.

DSC watching

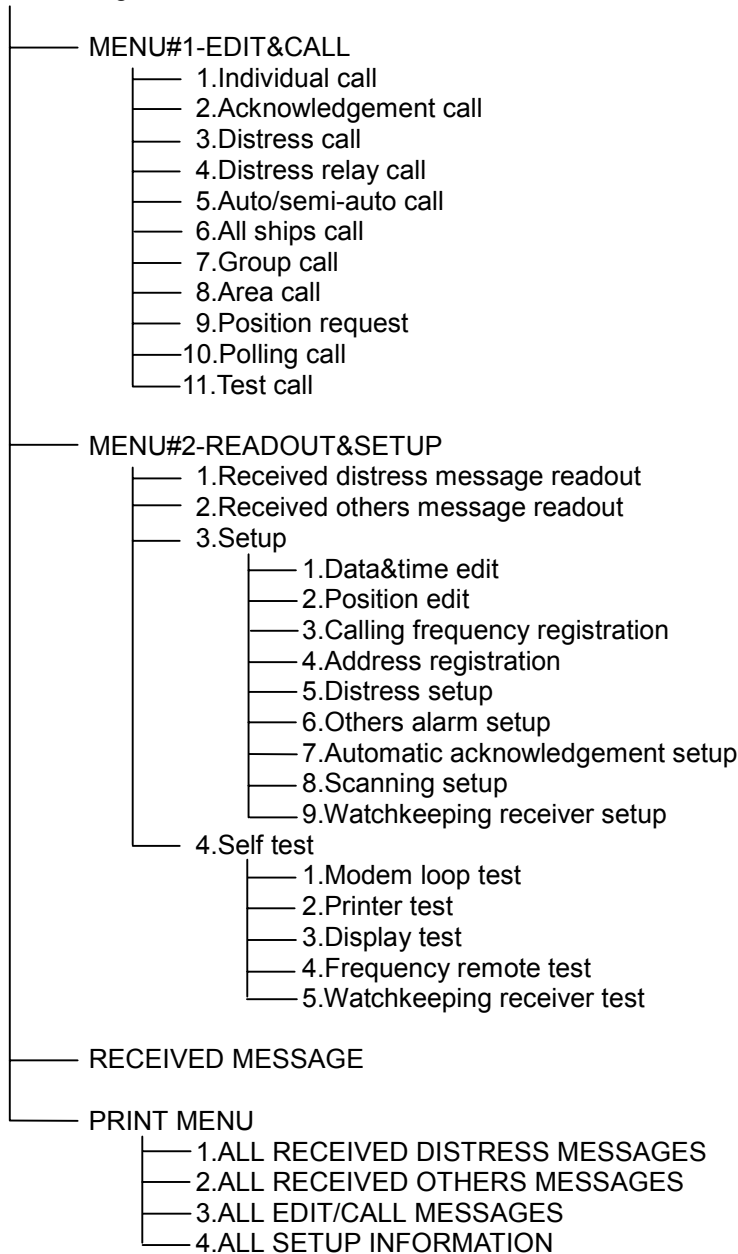

**(2) Transition Among Modes**

The following chart shows the keys and key combinations used to shift from one mode to another on the NCT-196N.

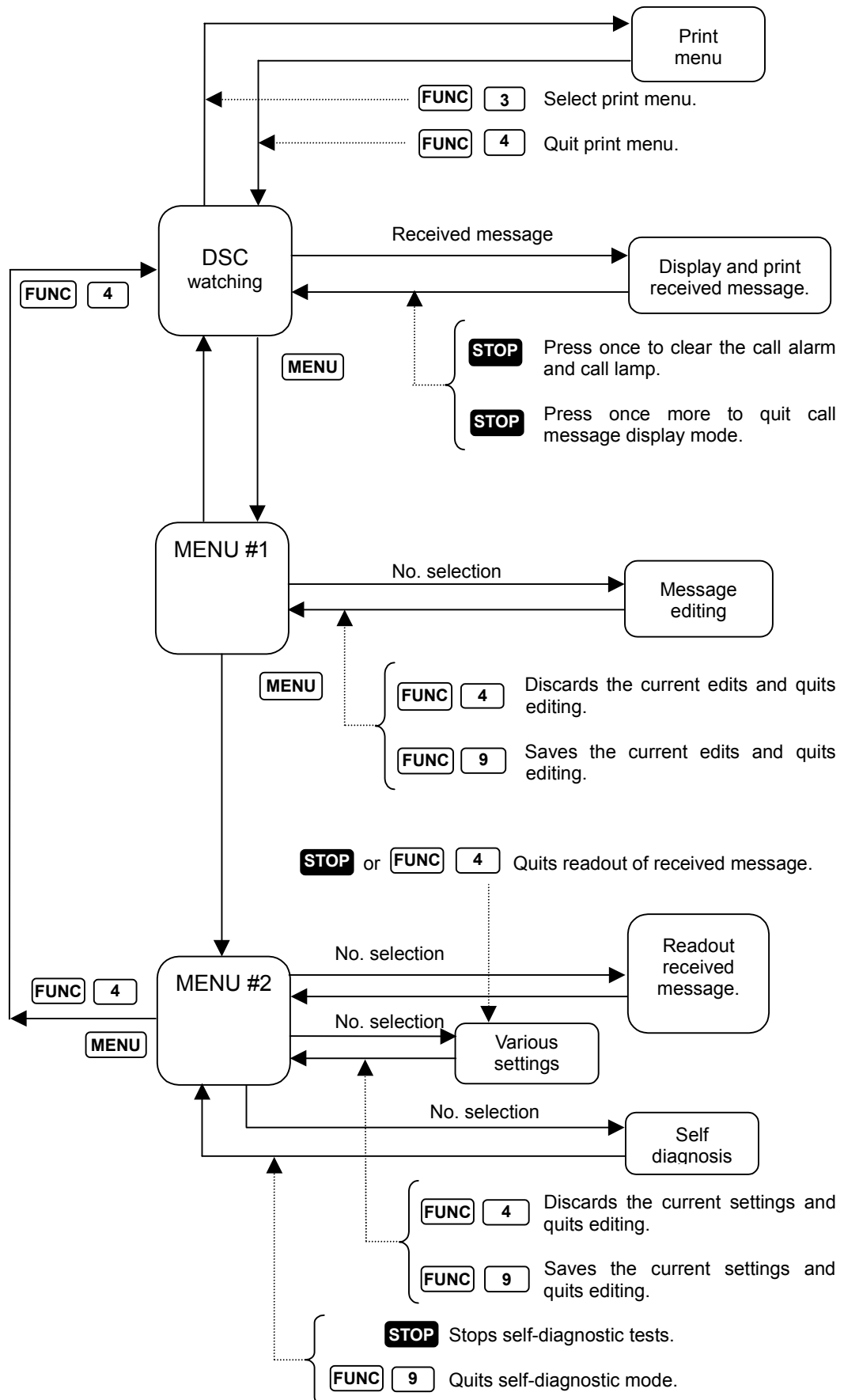

(From any mode, press **STOP** three times to return to "DSC watching.")

## 3.5.2 Receiving Messages

### (1) Receiving a Message

When a message is received, it is displayed on the screen and printed out on the printer, if a printer is connected. In addition, depending on its content, the message is classified as either a distress/urgent message or a general message and the corresponding panel lamp blinks. Simultaneously, a buzzer sounds to indicate which type of message has been received. The message is then saved as either a distress/urgent message or a general message.

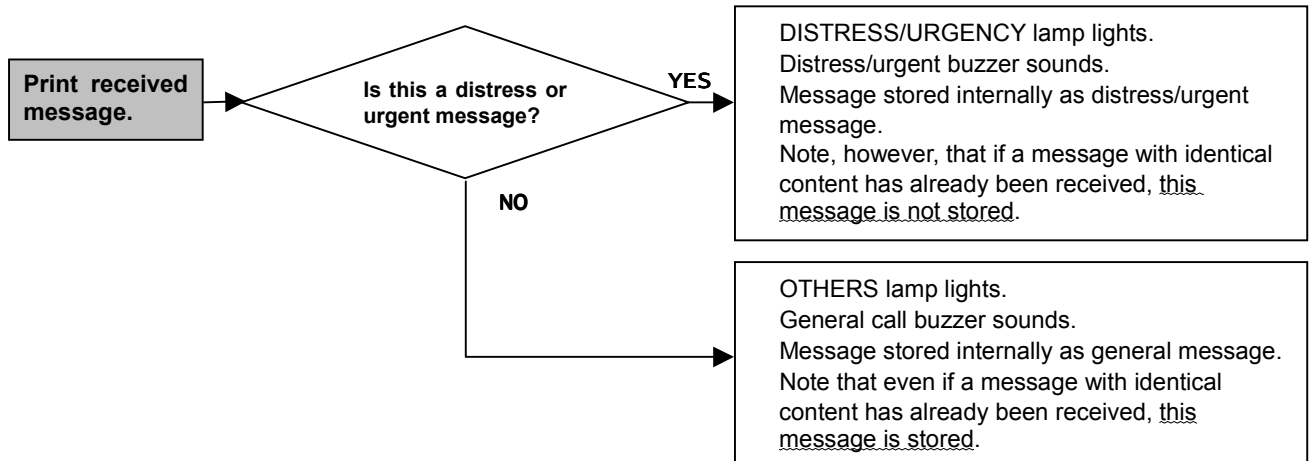

The NCT-196N stores up to 20 received distress/urgent messages and up to 20 general messages. When 20 messages have been stored, the oldest message is deleted each time a new message is received.

In case of distress/urgent messages, newly received messages are not stored if a message with the same content already exists in memory. However, if any error occurs while receiving the message, both of the messages containing the error and the error-free message are stored.

In case of general messages, the NCT-196N stores both the original message and the new message even if they have the same content as each other.

#### Note

Distress/urgent messages ..... Messages in "DISTRESS" format or for which the category is "DISTRESS" or "URGENCY".

General messages ..... Messages other than distress/urgent messages.

## (2) Reading a Distress/Urgent Message

Messages are loaded at the "DSC watching" screen.

### ATTENTION

To prevent unnecessary distress message relay transmission, the NCT-196N automatically deletes distress/urgency messages after 48 hours since these received. Thus the procedure above-mentioned to read distress message received is invalid at that time.

### Procedure

#### 1. Check that the "DSC watching" screen is displayed.

```
DSC watching 06.Sep.2001(Thu) 01:26 P
12°34'N123°45'E SPEED:12.4KT at 01:26
Self-ID = XXXXXXXXX [UTC]
```

### Note

If the "DSC watching" screen is not displayed, press **STOP** 3 times in succession to switch to the "DSC watching" screen.  
On the screen **P** mark is displayed when no printer is connected to the NCT-196N.

#### 2. Press **MENU**.

The "MENU#1-EDIT&CALL" screen is displayed.

```
MENU #1-EDIT&CALL      Select no._
▶ 1.Individual call
  2.Acknowledgement call
  3.Distress call
  4.Distress relay call
  5.Auto/semi-auto call
  6.All ships call
  7.Group call
  8.Area call
  9.Position request
 10.Polling call
 11.Test call
```

Use  and  to scroll.

#### 3. Press **MENU** again.

The "MENU#2-READOUT&SETUP" screen is displayed.

```
MENU #2 -READOUT&SETUP  Select no._
▶ 1.Received distress message readout
  2.Received others message readout
  3.Setup
  4.Self test
```

Use  and  to scroll.

**4. Press [1], and then press [ENT].**

The "RECEIVED DISTRESS MESSAGE READOUT" screen is displayed.

```
RECEIVED DISTRESS MESSAGE READOUT #01
RX date&time :06.Sep.2001(Thu) 01:26
Format      :DISTRESS
Address     :XXXXXXXXX
Nature      :UNDESIGNATED DIST
Dist-position :12° 34'N123° 45'E
Dist-UTC    :01:26
Dist-telecomm :J3E TEL
End of sequence:EOS
RX frequency : . kHz
```

Use [ ] and [ ] to scroll.

Use the horizontal cursor keys (◀) and (▶) to display other received messages.

**Note**

The following screen is displayed if no distress messages have been received or deleted after 48hours past.

```
RECEIVED DISTRESS MESSAGE READOUT

Received message not found !!
```

**5. After reading the message(s), press [FUNC], and then press [4].**

Operation returns to the "MENU#2 READOUT&SETUP" screen.

**6. Press [MENU].**

Operation returns to the "DSC watching" screen.

### (3) Reading a General Message

Messages are loaded at the "DSC watching" screen.

#### Procedure

**1. Press  twice to display the "MENU#2-READOUT&SETUP" screen.**

The screen shown in step 3 of "(2) Reading a Distress/Urgent Message" is displayed.

**2. Press , and then .**

```
RECEIVED OTHERS MESSAGE READOUT #01
RX date&time :06.Sep.2001(Thu) 01:26
Format      :INDIVIDUAL
Address     :XXXXXXXXXX
Category    :ROUTINE
Telecommand1 :J3E TEL
Telecommand2 :NO INFORMATION
Work TX/RX freq:12,321.0/12,343.2 kHz
End of sequence:ACK RQ
RX frequency :12,187.5 kHz
```

Use  and  to scroll.

#### Note

The following screen is displayed if no general messages have been received.

```
RECEIVED OTHERS MESSAGE READOUT

Received message not found !!
```

**3. After reading the message(s), press , and then press .**

Operation returns to the "MENU#2 READOUT&SETUP" screen.

**4. Press .**

Operation returns to the "DSC watching" screen.



### 3.5.3 Sending Messages

The following table lists the menus and menu items. When compiling a message, select the necessary items from these menus. Refer to the section on making calls for how to select the items for the respective call types.

Menu	Menu items	Content
FORMAT	INDIVIDUAL AUTO / SEMI - AUTO DISTRESS ALL SHIPS GROUP AREA	
CATEGORY	URGENCY SAFETY SHIP'S BUSINESS ROUTINE DISTRESS	
TELECOMMAND1	POLLING UNCOMPLY DATA MODEM J3E TEL F1B / J2B FEC TTY F1B / J2B ARQ TTY F1B / J2B REC TTY F1B / J2B TTY A1A MORSE RECORD SHIP'S POSITION A1A MORSE KEY F1C / F2C / F3C FAX NO INFORMATION F3E / G3E SIMP TEL F3E / G3E DUP TEL DISTRESS RELAY DISTRESS ACK END OF SEQUENCE TEST	
TELECOMMAND2	NO INFORMATION RES18SHIP / AIR MEDICAL TRANS PUB CALL OFFICE NO REASON CONGESTION BUSY QUEUE STATION BARRED NO OPERATOR NO OPR TEMPRY EQUIP DISABLED UNUSABLE FREQ UNUSABLE MODE ITU - T V.21 ITU - T V.22 ITU - T V.22 BIS ITU - T V.23 ITU - T V.26 BIS ITU - T V.26 TER ITU - T V.27 TER ITU - T V.32	

Menu	Menu items	Content
NATURE	UNDESIGNATED DIST ABANDONING EPIRB EMISSION FIRE / EXPLOSION FLOODING COLLISION GROUNDING LISTING SINKING DISABLED / ADRIFT MAN OVERBOARD PIRACY / ROBBERY	
TELECOMMAND	J3E TEL F3E / J3E SIMP TEL F3E / J3E DUP TEL F1B / J2B FEC TTY F1B / J2B ARQ TTY	
EOS	ACK RQ ACK BQ EOS	

**(1) INDIVIDUAL CALL**

Compiling and transmitting the message is enabled by specifying the address of a specific coastal or ship station.

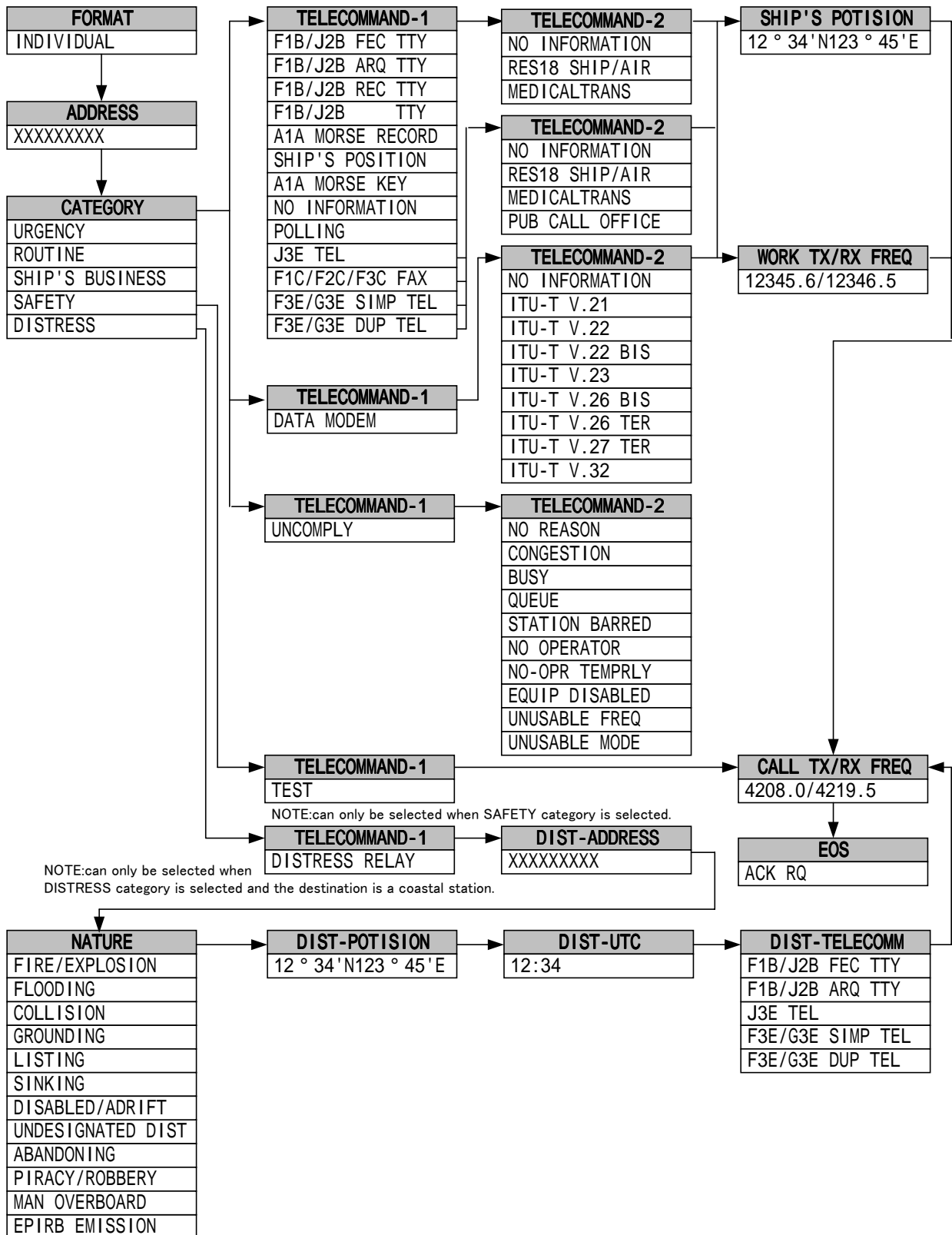

## Procedure

Example: ROUTINE procedure.

### 1. Check that the "DSC watching" screen is displayed.

```
DSC watching 06.Sep.2001(Thu) 01:26
12°34'N123°45'E SPEED:12.4KT at 01:26

Self-ID = XXXXXXXXXX [UTC]
```

### 2. Press **MENU**.

The "MENU#1-EDIT&CALL" screen is displayed.

```
MENU #1-EDIT&CALL      Select no._
▶ 1.Individual call
  2.Acknowledgement
  3.Distress call
  4.Distress relay call
  5.Auto/semi-auto call
  6.All ships call
  7.Group call
  8.Area call
  9.Position request
 10.Polling call
 11.Test call
```

Use  and  to scroll the screen.

### 3. Press **1**, and then press **ENT**.

The "INDIVIDUAL CALL" screen is displayed.

```
INDIVIDUAL CALL      Transmissible
▶ Address             : XXXXXXXXXX
Category             : ROUTINE
Telecommand-1       : J3E TEL
Telecommand-2       : NO INFORMATION
Ship's position     : 12°34'N123°45'E
Call TX/RX freq    : 4,208.0 / 4,219.5 kHz
```

Use  and  to scroll the screen.

The following items have been set in this example.

```
「Address」       : XXXXXXXXXX
「Category」     : ROUTINE
「Telecommand-1」 : J3E TEL
「Telecommand-2」 : NO INFORMATION
「Ship's position」 : 12°34'N123°45'E
「Call TX/RX freq」 : 4,208.0/4,219.5 kHz
```

### Entering the respective items:

After selecting each item, press **ENT** to confirm the selection.

- (1) Address: Use the numerical keys ( **0** to **9** ) to specify the address of the destination station (coastal or ship station).
- (2) Category  
Telecommand-1: Use the **◀** and **▶** keys to select the items.  
Telecommand-2
- (3) Ship's position: Use the **◀** and **▶** keys to determine the direction, and then input the ship's position using the numerical keys ( **0** to **9** ).
- (4) Call TX/RX freq: Use the **◀** and **▶** keys to select one of the preset frequencies, or use the numerical keys ( **0** to **9** ,and **.** ) to specify a frequency directly.
- (5) Other settings:
  - "Work TX/RX freq": Use the numerical keys ( **0** to **9** ,and **.** ) to specify a frequency directly.
  - Switching from "Ship's position" to "Work TX/RX freq": Press **FUNC** **6** (FREQ).
  - Switching from "Work TX/RX freq" to "Ship's position": Press **FUNC** **5** (POS).

### Note

Set the "Work TX/RX freq" to a frequency in the same band as "Call TX/RX freq".

### 4. Press **CALL**.

The following screen is displayed and the message is transmitted.

```
INDIVIDUAL CALL      Transmitting
TX frequency   : 4,208.0 kHz
TX date&time   : 06.Sep.2001(Thu) 01:30
```

When the transmission is completed, the following screen is displayed for a while, and the message is saved. After that returns to the "MENU#1-EDIT&CALL" screen.

```
INDIVIDUAL CALL      Send Completed
TX frequency   : 4,208.0 kHz
TX date&time   : 06.Sep.2001(Thu) 01:30
```

### Note

Refer to the example in "(6) ALL SHIPS CALL" for information on the DISTRESS RELAY procedure.  
To store a message without sending it, press **FUNC** **9** (SAVE).  
To discard the message and quit, press **FUNC** **4** (QUIT).

**(2) ACKNOWLEDGEMENT CALL**

In the event that the received general message requests acknowledgement, a message of acknowledgement is automatically produced. Creating and transmitting a distress acknowledgement message is also possible.

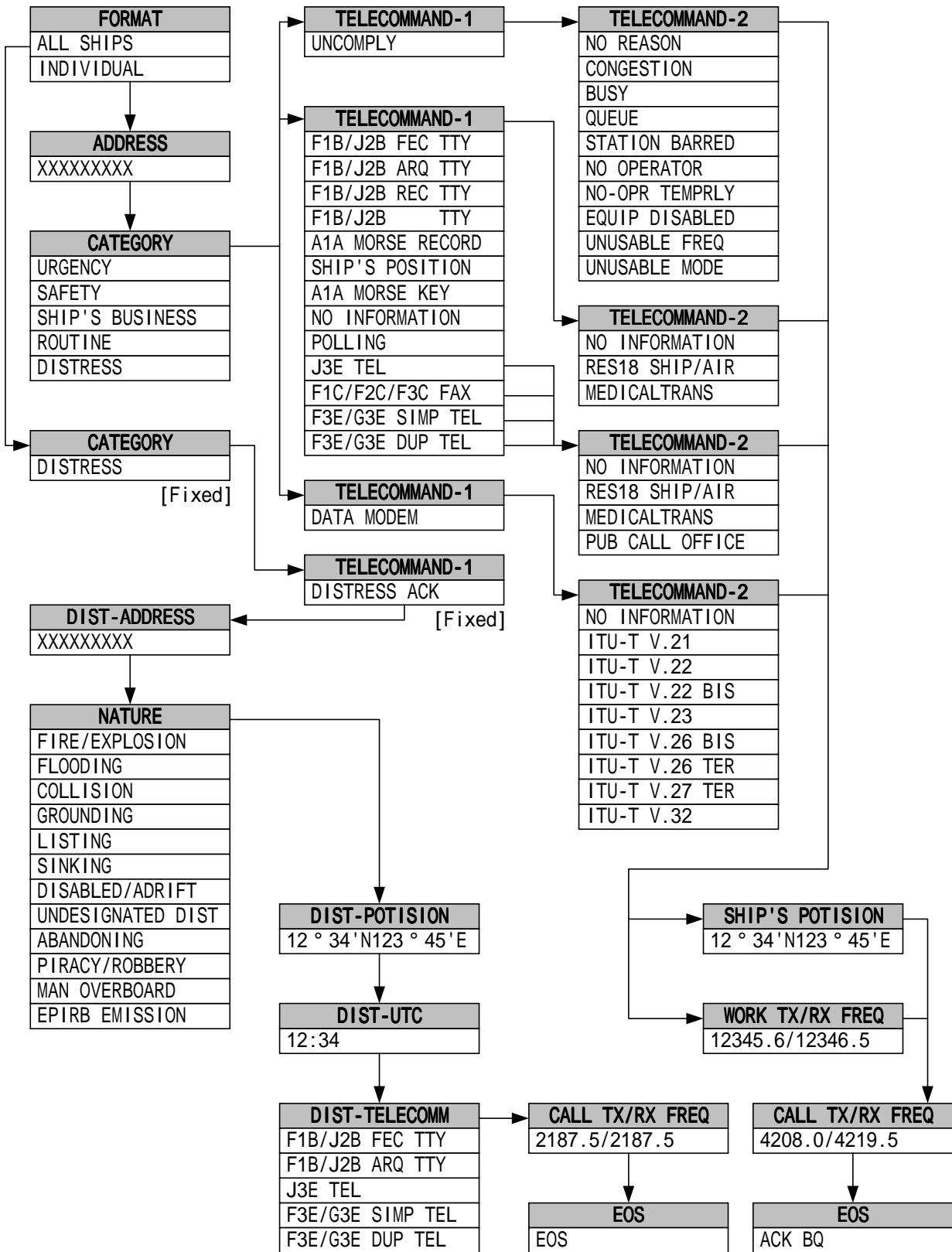

## (2-1) INDIVIDUAL ACK CALL

### Procedure

Example: An acknowledgement call based on the message received

1. From the "MENU#1-EDIT&CALL" screen, press **[2]**, and then press **[ENT]**.

The "Acknowledgement" screen is displayed.

```
ACKNOWLEDGEMENT          Select no._
▶ 1.INDIVIDUAL ack.      Rcv : 06.Sep.01:20
  2.INDIVIDUAL ack.      EDIT
  3.DISTRESS ack.        EDIT
```

### Note

- 1 :Select 1 to edit the received message.
- 2, 3 :Select 2 or 3 to edit a new acknowledgement message.

2. Press **[1]**, and then press **[ENT]**.

The "INDIVIDUAL ACK CALL" screen is displayed.

```
INDIVIDUAL ACK CALL
▶ Address      : XXXXXXXXX
  Category     : ROUTINE
  Telecommand-1 : J3E TEL
  Telecommand-2 : NO INFORMATION
  Work TX/RX freq : 12,345.6/12,456.7kHz
  Call TX/RX freq : 4,357.0/ 4,388.5kHz
```

Use **[ ]** and **[ ]** to scroll the screen.

The following items have been set in this example.

```
「Address」      : XXXXXXXXX
「Category」     : ROUTINE
「Telecommand-1」 : J3E TEL
「Telecommand-2」 : NO INFORMATION
「Work TX/RX freq」 : 12,345.6/12,456.7 kHz
「Call TX/RX freq」 : 4,357.0/4,388.5 kHz
```

### Entering the respective items:

After selecting each item, press **[ENT]** to confirm the selection.

- (1) Address: Use the numerical keys (**[0]** to **[9]**) to specify the address of the destination station (coastal or ship station).
- (2) Category  
Telecommand-1: Use the **[◀]** and **[▶]** keys to select the items.  
Telecommand-2
- (3) Work TX/RX freq: Use the numerical keys (**[0]** to **[9]**, and **[.]**) to directly specify a frequency.
- (4) Call TX/RX freq: Use the **[◀]** and **[▶]** keys to select one of the preset frequencies, or use the numerical keys (**[0]** to **[9]**, and **[.]**) to specify a frequency directly.
- (5) Other settings:
  - Switching from "Ship's position" to "Work TX/RX freq": Press **[FUNC]** **[6]** (FREQ).
  - Switching from "Work TX/RX freq" to "Ship's position": Press **[FUNC]** **[5]** (POS).

### 3. Press **CALL**.

The following screen is displayed and the message is transmitted.

```
INDIVIDUAL ACK CALL   Transmitting
TX frequency   : 4,357.0 kHz
TX date&time   : 06.Sep.2001(Thu) 01:30
```

#### Note

If the tuner is not tuned to the transmission frequency, the "tuner mismatch!!" warning message is displayed. Press **ENT** to tune the tuner, then transmit the message.

When the transmission is completed, the following screen is displayed for a while. After that returns to the "MENU#1-EDIT&CALL" screen.

```
INDIVIDUAL ACK CALL   Send Completed
TX frequency   : 4,357.0 kHz
TX date&time   : 06.Sep.2001(Thu) 01:30
```

#### Note

- Unable to store the message.
- To discard the message and quit without sending it, press **FUNC** **4** (QUIT).



## (2-2) DISTRESS ACK CALL

Perform the distress acknowledgement call as follows. The message is not made automatically because confirmation of the distress condition is necessary. Compile the acknowledgment message manually and then transmit it.

Compile the acknowledgment call so that the contents are the same as the received distress message.

### ATTENTION

When a distress call is received, perform communication according to "RECEPTION OF DSC DISTRESS ALERT".

## Procedure

**Example: Acknowledgement call procedure based on received distress message**

1. From the "MENU#1-EDIT&CALL" screen, press **[2]**, and then press **[ENT]**.

The "Acknowledgement" screen is displayed.

```
ACKNOWLEDGEMENT          Select no._
▶ 1.INDIVIDUAL ack.      Rcv : 06.Sep.01:20
  2.INDIVIDUAL ack.      EDIT
  3.DISTRESS ack.        EDIT
```

### Note

1 :Select 1 to edit the received message.

2, 3 :Select 2 or 3 to edit a new acknowledgement message.

2. Press **[3]**, and then press **[ENT]**.

The "DISTRESS ACK CALL" screen is displayed.

```
DISTRESS ACK CALL
▶ Dist-address      : XXXXXXXXXX
  Nature           : UNDESIGNATED DIST
  Dist-position    : 12° 34'N123° 45'E
  Dist-UTC         : 01:20
  Dist-telecomm    : J3E TEL
  Call TX/RX freq : 2,187.5 / 2,187.5 kHz
```

Use **[ ]** and **[ ]** to scroll the screen.

The following items have been set in this example.

```
「Address」      : XXXXXXXXXX
「Nature」       : UNDESIGNATED DIST
「Dist-position」 : 12° 34'N123° 45'E
「Dist-UTC」     : 01:20
「Dist-telecomm」 : J3E TEL
「Call TX/RX freq」 : 2,187.5/2,187.5 kHz
```

### Entering the respective items:

After selecting each item, press **[ENT]** to confirm the selection.

(1) Address: Use the numerical keys (**[0]** to **[9]**) to specify the address of the destination station (coastal or ship station).

(2) Nature

Dist-telecomm: Use the **[◀]** and **[▶]** keys to select the items.

- (3) Dist-position: Use the ◀ and ▶ keys to determine the direction, and then input the ship's position using the numerical keys (0 to 9).
- (4) Dist-UTC: Use the numerical keys (0 to 9) to enter the time.
- (5) Call TX/RX freq: Use the ◀ and ▶ keys to select one of the preset frequencies, or use the numerical keys (0 to 9, and .) to specify a frequency directly.

### 3. Press **CALL**.

The following screen is displayed and the message is transmitted.

```

DISTRESS ACK CALL   Transmitting
TX frequency : 2,187.5 kHz
TX date&time : 06.Sep.2001(Thu) 01:30
```

If the tuner is not tuned to the transmission frequency, the following screen is displayed. Press **ENT** to tune the tuner and then transmit the message.

```

tuner mismatch !!
Press [ENT] key to tune & send
Press [CLR] key to send
```

When the transmission is completed, the following screen is displayed and, after a brief interval, operation returns to the "MENU#1-EDIT&CALL" screen.

```

DISTRESS ACK CALL   Send Completed
TX frequency : 2,187.5 kHz
TX date&time : 06.Sep.2001(Thu) 01:30
```

**Note**

- Unable store the message.
- To discard the message and quit without sending it, press **FUNC** **4** (QUIT).

**(3) DISTRESS CALL**

Data such as the nature of the distress, position, and time can be compiled and transmitted in detail. A distress call is transmitted repeatedly at 3.5- to 4.5-minute intervals until acknowledgement is received.

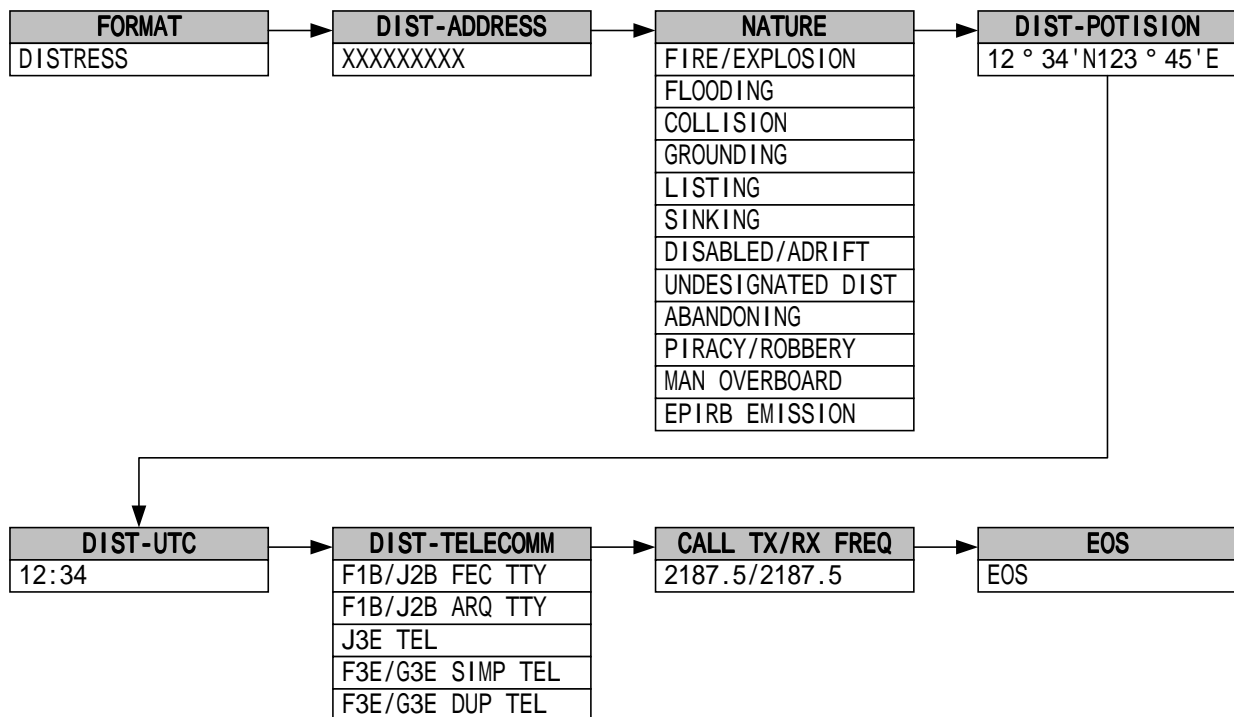

## Procedure

1. From the "MENU#1-EDIT&CALL" screen, press **[3]**, and then press **[ENT]**.

The "DISTRESS CALL" screen is displayed.

```

DISTRESS CALL          Transmissible
▶Address               : XXXXXXXXXX
Nature                 : UNDESIGNATED DIST
Dist-position          : 12° 34'N123° 45'E

Dist-UTC               : 01:20
Dist-telecomm          : J3E TEL
End of sequence        : EOS
Call TX/RX freq       : 2,187.5 / 2,187.5 kHz
  
```

Use **[ ]** and **[ ]** to scroll the screen.

The following items have been set in this example.

```

*「Address」           : XXXXXXXXXX
「Nature」             : UNDESIGNATED DIST
「Dist-position」      : 12° 34'N123° 45'E
「Dist-UTC」           : 01:20
「Dist-telecomm」      : J3E TEL
*「End of sequence」  : EOS
「Call TX/RX freq」    : 2,187.5/2,187.5 kHz
  
```

### Note

\* Not edit the these setting.

Entering the respective items:

After selecting each item, press **[ENT]** to confirm the selection.

- (1) Nature  
Dist-telecomm: Use the **[◀]** and **[▶]** keys to select the items.
- (2) Dist-position: Use the **[◀]** and **[▶]** keys to determine the direction, and then input the ship's position using the numerical keys (**[0]** to **[9]**).
- (3) Dist-UTC: Use the numerical keys (**[0]** to **[9]**) to enter the time.
- (4) Call TX/RX freq: Use the **[◀]** and **[▶]** keys to select one of the preset frequencies, or use the numerical keys (**[0]** to **[9]**, and **[.]**) to specify a frequency directly.

2. Press **[DISTRESS]** for at least 3.5 seconds (until the intermittent alarm tone changes to a continuous tone).

The following screen is displayed and the message is transmitted. The same distress message is sent 5 times in succession.

```

DISTRESS CALL          Transmitting
TX frequency           : 2,187.5 kHz
TX date&time           : 06.Sep.2001(Thu) 01:30
                                                                1/5
  
```

On completion of the transmission, the following screen is displayed. Transmission of the distress call is repeated when the displayed time has counted down to zero.

```

DISTRESS CALL          2,187.5 kHz
NEXT DISTRESS CALL : AFTER 3.7 min
  
```

### Note

Press **[STOP]** to cancel the DISTRESS transmission.  
 To store the message without sending it, press **[FUNC]** **[9]** (SAVE).  
 To discard the message and quit without sending it, press **[FUNC]** **[4]** (QUIT).  
 The distress call is sent repeatedly until a distress call acknowledgement is received.

## About Distress Calls

Distress calls, distress relay and distress acknowledgement functions are described here.

### Distress Call Transmission

Distress type	FORMAT	CATEGORY	TELECOMMAND-1	Operating keys	No. of transmissions
DISTRESS	DISTRESS	-	-	DISTRESS	5 successive transmissions with intervals
DISTRESS	DISTRESS	-	-	CALL > DISTRESS	5 successive transmissions with intervals
DISTRESS	INDIVIDUAL ALL SHIPS GROUP AREA	DISTRESS	J3E TEL, etc.	CALL > DISTRESS	Once only
DISTRESS RELAY	INDIVIDUAL	DISTRESS	DISTRESS RELAY	CALL > DISTRESS	Once only
DISTRESS RELAY	ALL SHIPS	DISTRESS	DISTRESS RELAY	CALL > DISTRESS	Once only
DISTRESS ACK	ALL SHIPS	DISTRESS	DISTRESS ACK	CALL	Once only

### Distress Calls

When transmitting without editing and using only the **DISTRESS** key, the message with the contents previously compiled in the distress setting is transmitted. This message is transmitted five times successively at 3.5- to 4.5-minute intervals.

The following are two ways of distress transmitting after editing:

1. Transmitting details of distress conditions

This transmission is made according to 3.5.3 (3), "DISTRESS CALL." The nature of the distress, the ship's position, time, and communication method are transmitted. The message is transmitted five times successively at 3.5- to 4.5-minute intervals.

This is the primary method.

2. This transmission includes INDIVIDUAL, ALL SHIPS, GROUP, and AREA, and it is enabled when "DISTRESS" is selected for the CATEGORY. The contents of the message are the same as other messages. This message is transmitted only once.

### DISTRESS RELAY CALL

This transmission is made according to 3.5.3 (4), "DISTRESS RELAY CALL." The message to be transmitted can be edited by selecting "DISTRESS" for FORMAT and "DISTRESS RELAY" for CATEGORY in individual or all ships calls. However, the contents are the same. The received message is edited so that it is the same as the received distress message. It is then transmitted to a coastal station. This message is transmitted only once.

### DISTRESS ACK CALL

This transmission is made according to 3.5.3 (2), "ACKNOWLEDGEMENT CALL (2-2)." The message is not created automatically because the contents need to be confirmed. The acknowledgement message is edited manually and then transmitted. It is necessary to edit the message to be transmitted according to the contents of the received message. This message is transmitted only once by using **CALL** key.

## ATTENTION

When a distress message is received, make the transmission according to "RECEPTION OF DSC DISTRESS ALERT".