

# NJJ-200

## Handy Search Users Guide

(For FCC and CE Version)



# **I. Preface**

Thank you very much for purchasing JRC NJJ-200 Handy Search. This product nondestructively locates, detects, and displays the depths and positions of rebars in reinforced concrete structures.



- Before starting to use this product read this manual carefully to ensure correct and trouble-free operations.
- Keep this manual handy for reference. Refer to the manual when facing uncertainties or when experiencing troubles during operation.

DC20 – NJJ-200  
Firust Edition Nov 2013





## II. Before Operation

### Pictorial Indication

Various icons are indicated in this manual and are labeled on this product to ensure your safe and correct operations and to prevent any danger to you and/or other persons and any damage to your property during operation. Such indications and their meanings are as follows. Please understand them before reading this manual.













 <b>WARNING</b>	This indication is shown when danger of being killed or seriously injured is possible if this indication is neglected and this product is not operated correctly.
 <b>CAUTION</b>	This indication is shown when injury or property damage is possible if this indication is neglected and this product is not operated correctly.

### Examples of Pictorial Indication













 Electric shock		A $\Delta$ mark indicates CAUTION (including DANGER and WARNING). Detailed content of the specific CAUTION (“Electric Shock” in the example on the left.) is shown in the mark.
 Disassembling Prohibited	 Prohibition	A $\circ$ mark indicates prohibition. Detailed content of the prohibited action (“Disassembling Prohibited” in the example on the left.) is shown in the mark.
 Disconnect the power plug	 Instruction	A $\bullet$ mark indicates instruction. Detailed content of the instruction (“Disconnect the power plug” in the example on the left.) is shown in the mark.

- JRC assumes no liability for any damage (such as damage caused to rebars, electrical pipes, gas pipes, etc.) arising from scan results using this product.
- JRC assumes no liability for any damage arising from the disappearance of scan results stored in memory cards.
- Make sure to select and use Smartphone which is confirmed that it can be connected to the sensor unit by referring to Smartphone’s manual. For the requirements to Smartphone, refer to Section 13.4 Smartphone. JRC assumes no liability for any damage (such as damage caused to Smartphone and the sensor unit, etc.) arising from the incorrect operation different from the operation described in this manual.

### III. Precautions for Use

 <b>WARNING</b>	
	Do not use any battery pack other than the recommended battery packs. Doing so may cause fire, electric shock, or breakdown.
	Do not short-circuit the terminals of the battery charger or battery pack. Doing so may cause fire, explosion, or breakdown.
	Do not insert metallic or flammable objects into the CF memory slot. Doing so may cause injury, fire, electric shock, or breakdown.
	Do not disassemble, modify, heat, or place battery pack in fire. Doing so may cause fire, explosion, or breakdown.
	Do not use any charger other than the recommended battery charger to charge the battery pack. Doing so may cause fire, electric shock, or breakdown.
	Do not disassemble, modify, or repair this product by yourself. Doing so may cause fire, electric shock, or breakdown.
	If the power cord is damaged (exposure of the core wire, open circuit failure, or break in the sheath), contact our nearest branch office (See Section 14), sales outlet, or service station for a replacement power cord. Use of a damaged power cord may cause fire or electric shock.
	Do not connect/disconnect the power plug by wet hands. Doing so could cause an electric shock.
	Do not use (place) this product in a location where it is exposed to flammable or corrosive gas. Doing so could cause fire, personal injury, or breakdown.
	This product has a waterproof construction but must not be dipped in water. Do not expose this product to water or moisture, and do not use it in rainy weather. Doing so could cause an electric shock or breakdown.
	Stop using this product immediately when a sign of malfunctioning is detected, and follow only the instruction described in Section 9.3 Troubleshooting. If it cannot be restored to normal operation, contact our nearest branch office (See Section 14), sales outlet, or service station. Use of this product in an abnormal state could cause fire or breakdown.
	Should this product emit an abnormal sound, odor, or smoke, immediately turn off the power switch, remove the battery pack, disconnect the power plug from the socket outlet, and contact our nearest branch office (See Section 14), sales outlet, or service station. Use of this product in an abnormal state could cause fire, electric shock, or breakdown.

 **CAUTION**

	Before disposing of the used lithium ion battery, insulate the charging terminals by taping or the like. Otherwise, the battery could cause fire or explosion if short-circuited.
	Judge the scan result with considering the depth sensing capability of this product. Since the depth scan capability of this product is subject to the conditions of the object of investigation, judging the scan result with no consideration of the depth scan capability may cause the cutting of rebars.
	Put your hand through the hand strap and hold this product. Dropping of this product may cause an accident such as a device breakdown or personal injury.
	When disconnecting the power cord, hold the plug. Pulling the power cord by itself may cause cord damage, fire, or electric shock.
	Do not place this product on an unstable place such as a wobbly table or sloping surface. Doing so may cause a personal injury or breakdown when it drops or falls.
	Do not use (place) this product in a humid or dusty location, or a location where water, oil, or chemical may splash onto this product. Doing so may cause fire, electric shock, or breakdown.
	Do not use (place) this product in a location where it is subject to vibration or shock. Doing so may cause a personal injury or breakdown.
	When loading/unloading printing paper, be careful not to cut or jam your fingers in the printer. Otherwise a personal injury, accident, or breakdown may be caused.
	Point the antenna surface in the direction of the object (concrete) while you are performing a probe. If it is pointed into the air or otherwise unsuitable direction, it can cause malfunction of other equipment or other such accidents.
	Do not use this product near a radio or TV set. Doing so may cause noise or poor reception such as disturbance of television pictures. Doing so also adversely affects the depth sensing capability of this product, and may cause the cutting of rebars.
	Do not use this product near a transceiver that transmits electromagnetic waves. Electromagnetic waves from the transceiver may adversely affect the depth sensing capability of this product, and may cause the cutting of rebars.
	When this product is used for probing on a road, take safety precautions such as providing guard fences to prevent traffic accidents.



## CAUTION



IMPORTANT NOTE: To comply with FCC & IC RF exposure compliance requirements, the antenna used for this transmitter must be installed to provide a separation distance of at least 20 cm from all persons and must not be co-located or operating in conjunction with any other antenna or transmitter.

**IV. Appearance**





## V. Glossary of Terms

A-mode	Displays received waveform as it is. The conditions of concrete directly underneath this product are displayed as reflected waveform in real time.
B-mode	Displays the vertical cross section of a scan point by gradating the reflected waveform shown in A-mode according to reflection intensity and continuously displaying it.
BA-mode	Displays both B-mode and A-mode images at the same time.
Real time auto surface wave processing	Image processing to automatically remove the unwanted waves reflected from the concrete surface during scanning by using the internal fixed surface wave data and shows only the reflected wave from rebars etc.
Real time manual deduction processing	Image processing used in the case where the unwanted waves reflected from the concrete surface can not be fully removed by using the real time auto surface wave processing and the unwanted waves remain as the form of stripes in the scan result. In this Image processing, an arbitrary line is designated while scanning. The data of the designated line is subtracted from the scan result data, and the reflected wave from the concrete surface is automatically removed. Thus, only the reflected waves from rebars etc. are shown.
Real time auto user surface wave processing	Image processing to automatically remove the unwanted waves reflected from the concrete surface during scanning by using the surface wave data which are defined by the user and stored in the product and shows only the reflected wave from rebars etc.
Fixed surface wave processing	Image processing to remove the unwanted waves reflected from the concrete surface by using the internal fixed surface wave data and shows only the reflected wave from rebars etc.
User surface wave processing	Image processing to remove the unwanted waves reflected from the concrete surface by using the surface wave data which are defined by, used, and stored in the product. This image processing shows only the reflected wave from rebars etc.

## Glossary of Terms (continued)

Deduction processing	Image processing to remove the stripe reflected waves throughout the entire depth, such as reflected waves from the concrete surface and from the rear surface etc. In this processing, an arbitrary line in the scan result is designated and the designated line is subtracted from the scan result data. Only the reflected waves from rebars etc. are shown.
Manual surface wave processing	Image processing to remove the unwanted waves reflected from the concrete surface by using the surface wave data of the designated position in the search results and shows only the reflected waves from rebars etc. In this processing, an arbitrary line is designated from scan results. The surface portion of the designated line is subtracted from the scan result data, and the reflected waves from the concrete surface are removed.
Average wave processing	Image processing to remove the stripe reflected waves throughout the entire depth, such as reflected waves from the concrete surface and from the rear surface etc. In this processing, the averaged waveform of the entire scan results data are calculated and is subtracted from the scan result data, Only the reflected waves from rebars etc. are shown.
Peak processing	Image processing that shows only the waveform of the first peak on the +side of the scan result. This enables removal of multiple reflected signals and only displays the upper rebars.
Original image	Restores the image processed result to the original state and displays unprocessed raw data.
Distance feed scan	Scan method that performs scanning in accordance with Handy Search's traveling distance, using the distance detector mounted on the wheels of this product.
Time feed scan	Scan method that performs B-mode scanning at preset time intervals, regardless of movement of this product.
Relative dielectric constant	Object-specific coefficient. The radio wave propagation velocity changes with the relative permittivity (dielectric constant). Therefore, the wave propagation velocity and search depth change based on the relative permittivity of the concrete. Calculation error of search depth can be reduced by setting a depth calibration value.

## Contents

I. Preface .....	i
II. Before Operation.....	ii
III. Precautions for Use.....	iii
IV. Appearance .....	vi
V. Glossary of Terms .....	vii
1. Product overview .....	1
1.1. FUNCTIONS AND PERFORMANCES.....	2
1.2. FEATURES.....	3
1.3. CONFIGURATION .....	5
1.4. OVERALL SYSTEM DIAGRAM .....	6
1.5. NAME AND FUNCTION OF EACH PART .....	7
2. Preparation before starting to use .....	10
2.1. OVERVIEW OF PREPARATION .....	10
2.2. NJJ-200 APPLICATION INSTALLATION .....	11
2.3. SMARTPHONE LANGUAGE SETUP .....	17
2.4. ATTACHMENT AND DETACHMENT OF THE HANDLE.....	17
2.5. ATTACHMENT OF THE HANDSTRAP .....	18
2.6. ATTACHMENT OF THE BATTERY PACK .....	19
2.7. DETACHMENT OF THE BATTERY PACK.....	20
2.8. COMMUNICATION SETUP .....	21
2.9. ATTACHMENT AND DETACHMENT OF SMARTPHONE.....	24
3. Basic scan procedure .....	25
3.1. PREPARATION FOR SCANNING LINES .....	27
3.2. BATTERY CAPACITY CHECK.....	28
3.3. SCANNING .....	30
3.4. INTERPRETING THE SCAN RESULTS .....	33
3.5. POWER OFF.....	34
3.6. SHUTDOWN AND STORAGE .....	34
4. NJJ-200 application functions.....	35
4.1. MAIN SCREEN.....	35
4.2. CURSOR AND SCROLL.....	38

4.3.	[MARK] ICON .....	39
4.3.1.	MARKER ADDITION .....	39
4.3.2.	MARKER DELETION .....	40
4.3.3.	MARKER LIST .....	41
4.4.	[FILE/PRINT] ICON .....	43
4.5.	[PARAMETER] ICON .....	44
4.5.1.	[COLOR] MENU .....	44
4.5.2.	[UNIT] MENU .....	46
4.6.	[DISPLAY MODE] ICON .....	48
4.7.	[RELATIVE PERMITTIVITY] ICON .....	49
4.7.1.	RELATIVE PERMITTIVITY AND DEPTH CALIBRATION .....	50
4.8.	[VIEW RANGE] ICON .....	51
4.9.	[SENSITIVITY] ICON .....	52
4.9.1.	SENSITIVITY .....	53
4.10.	[IMAGE PROCESSING] ICON .....	54
4.10.1.	IMAGE PROCESSING .....	55
4.10.2.	FIXED SURFACE PROCESSING .....	56
4.10.3.	USER SURFACE PROCESSING .....	56
4.10.4.	SUBTRACTION .....	59
4.10.5.	MANUAL SURFACE PROCESSING .....	61
4.10.6.	AVERAGING .....	63
4.10.7.	PEAK PROCESSING .....	64
4.10.8.	ORIGINAL IMAGE .....	65
4.11.	PARAMETER SETUP SCREEN .....	66
4.11.1.	DEVICE SETTING: [RELATIVE PERMITTIVITY] MENU .....	67
4.11.2.	DEVICE SETTING: [SENSITIVITY] MENU .....	68
4.11.3.	DEVICE SETTING: [VIEW RANGE] MENU .....	69
4.11.4.	DEVICE SETTING: [IMAGE PROCESSING] MENU .....	70
4.11.5.	DEVICE SETTING: [COLOR] MENU .....	71
4.11.6.	DEVICE SETTING: [DEVICE ORIENTATION SETTING] MENU .....	73
4.11.7.	DEVICE SETTING: [UNIT] MENU .....	74
4.11.8.	DEVICE SETTING: [LOCATION NOTIFICATION] MENU .....	75
4.11.9.	DEVICE SETTING: [SOUND] MENU .....	75
4.11.10.	PREFERRED SETTING: [RELATIVE PERMITTIVITY] MENU .....	76
4.11.11.	PREFERRED SETTING: [SENSITIVITY] MENU .....	76
4.11.12.	PREFERRED SETTING: [RANGE] MENU .....	77
4.11.13.	PREFERRED SETTING: [COLOR] MENU .....	77
4.11.14.	PREFERRED SETTING: [UNIT] MENU .....	78
4.11.15.	SENSOR SETTING: [MEASUREMENT MODE] MENU .....	79
4.11.16.	SENSOR SETTING: [LED] MENU .....	80
4.11.17.	SENSOR SETTING: [DISTANCE CORRECTION] MENU .....	80
4.11.18.	SENSOR SETTING: [CHANNEL] MENU .....	81
4.11.19.	OTHER: [SENSOR SELECT] MENU .....	82
4.11.20.	OTHER: [VERSION] MENU .....	83
4.11.21.	OTHER: [INITIAL SETTING] MENU .....	84
4.12.	FILE OPERATION SCREEN .....	85



4.12.1.	[OPEN] MENU.....	86
4.12.2.	[SAVE/PRINT] MENU .....	87
4.12.3.	[SELECT FOLDER] MENU.....	88
4.12.4.	[DATA NUMBER SETTING] MENU .....	89
4.13.	MARKER OPERATION.....	90
4.13.1.	[HIDE MARKERS] MENU .....	90
4.13.2.	[SHOW MARKER LIST] MENU .....	91
4.13.3.	[MARKER DETAILS] MENU .....	92
4.13.4.	[SORT MARKER] MENU .....	94
4.13.5.	[AUTOMARK] MENU .....	94
4.13.6.	[MARKER GROUP SETTING] MENU .....	95
<b>5.</b>	<b>External output .....</b>	<b>96</b>
5.1.	SAVE THE SCAN RESULT INTO THE FILE.....	96
5.1.1.	BINARY FORMAT.....	96
5.1.2.	TEXT FORMAT.....	99
5.2.	SAVING THE SCAN DATA .....	100
5.3.	DATA FILE OPERATION .....	102
5.4.	DISPLAYING THUMBNAIL IMAGE OF THE DATA FILE.....	103
5.5.	READING THE SCAN DATA FROM THE DATA FILE.....	104
5.6.	DELETING THE DATA FILE.....	105
5.7.	DELETE ALL FILES UNDER THE FOLDER .....	106
5.8.	PRINTER OUTPUT .....	107
5.8.1.	PREPARATION FOR THE PRINTER .....	107
5.8.2.	BLUETOOTH PAIRING.....	114
5.8.3.	PRINTING SCAN DATA .....	117
<b>6.</b>	<b>Application .....</b>	<b>120</b>
6.1.	RELATIVE PERMITTIVITY SETUP.....	120
6.2.	PROCEDURE TO MARK THE REBAR .....	125
6.2.1.	FORWARD SCAN MARKING .....	125
6.2.2.	BACKWARD SCAN MARKING .....	126
6.3.	AUTOMARK FUNCTION .....	127
6.4.	LOCATION NOTIFICATION FUNCTION .....	133
6.5.	SCREEN ROTATION .....	137
6.6.	SORT MARKER .....	138
6.7.	COMMUNICATION CHANNEL SETUP .....	141
6.8.	DISTANCE ERROR CORRECTION.....	142
6.9.	SOFTWARE VERSION UP .....	143
6.9.1.	SMARTPHONE APPLICATION VERSION UP .....	143
6.9.2.	SOFTWARE VERSION UP FOR SENSOR UNIT .....	149
<b>7.</b>	<b>Battery pack and battery charger .....</b>	<b>153</b>
7.1.	BATTERY PACK HST30002 .....	154
7.2.	BATTERY CHARGER PPT20003 .....	155

8. Theory.....	156
8.1. APPLICABLE CONDITION.....	157
9. Maintenance and inspection.....	158
9.1. DAILY INSPECTION.....	158
9.2. DAILY MAINTENANCE.....	158
9.3. TROUBLESHOOTING.....	159
10. After sales service.....	161
11. Disposal.....	162
11.1. DISPOSAL OF THE USED BATTERY PACK.....	162
11.2. DISPOSAL OF THIS PRODUCT.....	162
12. Regulation Note.....	163
12.1. FCC/IC CAUTION.....	163
12.2. FCC NOTICE (FOR U.S. CUSTOMERS):.....	164
13. Specifications.....	166
13.1. HANDY SEARCH NJJ-200.....	166
13.2. BATTERY PACK HST30002.....	168
13.3. BATTERY CHARGER PPT20003.....	168
13.4. SMARTPHONE.....	168
14. Where to contact.....	169

## 1. Product overview

To extend the life of concrete buildings, continuing the inspection and implementing renovation and repair appropriately of the buildings is essential. At the same time, the accurate and quick method for the building inspection is required to promote the building maintenance. This product is indispensable for repairing/rebuilding and maintaining reinforced concrete structures using its accurate and speedy diagnostic technology.

This product (concrete internal probe device) radiates electromagnetic waves through the surface of concrete and receives reflected signals from objects inside the concrete such as rebars, cavities, or other objects that have different electrical characteristics from concrete. Object position and depth are then displayed and recorded as image data.

 <b>CAUTION</b>	
	Judge the scan result in consideration of the depth sensing capability of this product. Since the depth sensing capability of this product is subject to the conditions of the object of investigation, judging the scan result with no consideration of the depth sensing capability may cause the accidental cutting of rebars.
	<b>IMPORTANT NOTE:</b> To comply with FCC & IC RF exposure compliance requirements, the antenna used for this transmitter must be installed to provide a separation distance of at least 20 cm from all persons and must not be co-located or operating in conjunction with any other antenna or transmitter.

## 1.1. Functions and performances

Table 1-1 shows functions and performances of this product..

**Table 1-1 Functions and performances (1/2)**

No.	Item		Functions and Performances
1	Search method		Electromagnetic wave radar method
2	Search object		Rebar, Polyvinyl-chloride pipe, Cavity, etc.
3	Search depth		5 to 300 mm for concrete having a relative dielectric constant 6.2 and the top rebar of the diameter $\geq 6$ mm
4	Depth resolution		Approx. 1 mm at the view range setting of Shallow Approx. 2 mm at the view range setting of Deep
5	Horizontal discrimination resolution		$\geq 75$ mm for the scanned object located at depth $< 75$ mm $\geq$ Depth of the scanned object located at depth $\geq 75$ mm ※Typical performance for the reference concrete provides discrimination between two rebars of the interval 15 mm at depth 75 mm and of the interval 40 mm at depth 175 mm.
6	Horizontal distance resolution		2.5 mm
7	Maximum scan distance		No limit (The scan data shown on Smartphone screen and saved into the file is maximum 15 m of the latest scan data from the scan stop point.)
8	Display mode		B-mode (Vertical Cross Section) and BA-mode(Vertical Cross Section and Reflection Waveform Graph)
9	Image processing	When scanning	Real time auto surface wave processing, Real time manual deduction processing, Real time user surface wave processing
		At idle state	Fixed surface wave processing, User surface wave processing, Deduction processing, Manual surface wave processing, Average wave processing, Peak processing, Original image
10	Depth calibration		2.0 to 20.0 ( 0.1 step) and time
11	Maximum scan speed		Approx. 40 cm/s, Over speed alarm capability
12	Control functions		Marker functions, Battery capacity indicator, Screen rotation, AutoMark function, Location notification function, File operations, Image data processing, Display functions (color, etc)
13	Data output functions		Data saving into the memory inside Smartphone (Approx. 100 scan data (15 m scan data of binary format) can be saved into the memory of 1 GB capacity) Print out to the optional printer: Monochrome printer
14	Scan dead space		$\leq 80$ mm



## 1.2. Features

This product has the following features. This product can:

**(1) Detect either metallic or non-metallic object.**

Reflected electromagnetic waves are generated at an interface when the electrical property of an object is different from that of concrete. Thus, this product can probe polyvinyl-chloride pipes and cavities (dependent on the position and size) as well as the rebar. Note that polyvinyl-chloride pipes and cavities echo weakly in compared with the rebar. If a polyvinyl-chloride pipe or cavity is near or below the rebar, the reflected signals from the polyvinyl-chloride pipe or cavity may not be obtained due to the strong reflected signals from the rebar. Thus, care should be taken when you make a judgment on the scan result.

**(2) Detect rebars that cross the scanning direction.**

Rebars that cross the scanning direction make a large magnetic wave reflection. On the other hand, the rebar that is parallel to the scanning direction makes a smaller magnetic wave reflection. Even if scanning is performed above rebars that is parallel to the scanning direction, this product can still detect any rebars that are crosswise to the scanning direction.

**(3) Obtain continuous scan results.**

The scan result are obtained as a representation of the vertical cross section (continuous scan result) of the inside of concrete. Thus, a comprehensive view of the internal concrete conditions can be obtained.

**(4) Obtain scan results at the site.**

This product does not need to be secured to the surface of concrete. Scanning is carried out while this product is moved, and scan results concerning the internal conditions of the concrete can be provided immediately.

**(5) Save and recall scan data.**

The scan data can be saved and recalled to/from an internal memory of Smartphone (controller). The data saved in Smartphone can also be sent to an external PC by using PC connection function of Smartphone.

**(6) Print the scan data without cable connection.**

The scan data can be printed out to the optional printer via the Bluetooth interface of Smartphone as the controller.

**(7) Perform real time automatic surface wave processing**

Internal fixed surface wave data is used to automatically remove the wave reflected from the concrete surface during scanning enabling the showing of the reflected wave from rebars. Furthermore, surface wave processing can be switched to processing that uses scan data surface waves during scanning (real time manual deduction) enabling highly accurate surface processing.

**(8) Change sensitivity and perform image processing for scan data after completing the scan.**

This product can display scan results after changing sensitivity or performing image processing (manual surface wave processing, peak processing, original image, fixed surface wave processing, or deduction processing). Thus, performing a scanning again with a new sensitivity setting is not necessary.

**(9) Display the data of an arbitrary point after scanning (scroll function).**

This product can store the data of 15 m width at a time and display the data of arbitrary points continuously.

**(10) Compact and light weight.**

This product weighs only about 1.0 kg(not including the controller: Smartphone), and it has easy operations.

**(11) Operate with the battery pack.**

This product (sensor unit not including the controller) can operate with the battery pack for about 7 hours (at normal temperature).

## 1.3. Configuration

### (1) Standard configuration

Table 1-2 shows the standard configuration of this product.

**Table 1-2 Standard Configuration**

Name	Model Number	Qty	Remarks
Handy search	NJJ-200	1	Sensor unit and handle
Battery pack	HST3002	1	For sensor unit
Battery charger	PPT20003	1	
AC cable	28AD0-J	1	For battery charger
Hand strap	MPXP35073	1	
Storage box	MPBX48072	1	
Controller application software	H-7YRBD0007	1	CD-R
Interface cable between Smartphone and a PC	—	1	USB cable
Users manual	DC00-NJJ-200	1	This manual
Quick operation guide	DC10-NJJ-200	1	
Test results	—		

### (2) Option

Table 1-3 shows optional accessories that are available in addition to the standard components.

**Table 1-3 Options**

Name	Model Number	Remarks
Controller	—	Smartphone
Battery pack	HST30002	For the sensor unit
Battery charger	PPT20003	For the battery pack used in the sensor unit
Printer	PD-24BT	Including an operation manual, a battery pack, an AC adapter, and a printing paper (1 ea)
Printing paper	RP11250T	One box including 10 paper rolls
Battery pack for the printer	PD69910	
AC adapter for the printer	PD79936-00F	
AC cable for the printer	PD79914-0S	
Charger for the printer	PD69922	
Extension bar	MPBC38332	
Calibration certification	—	
Traceability certification	—	

## 1.4. Overall system diagram

Figure 1-1 shows the overall system diagram of this product.

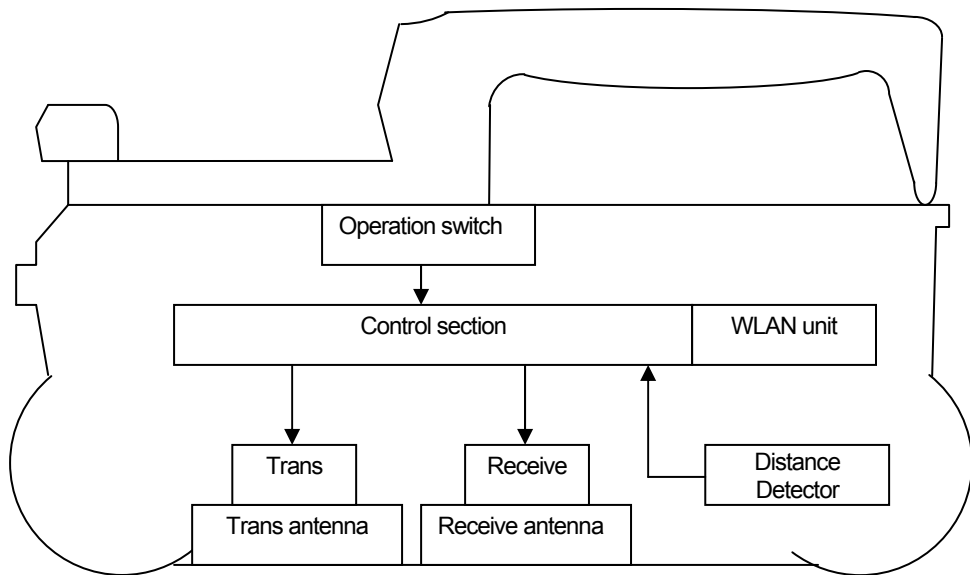

**Figure 1-1 System Diagram**

## 1.5. Name and function of each part

This section shows the name and function of each part of NJJ-200 sensor unit and handle.

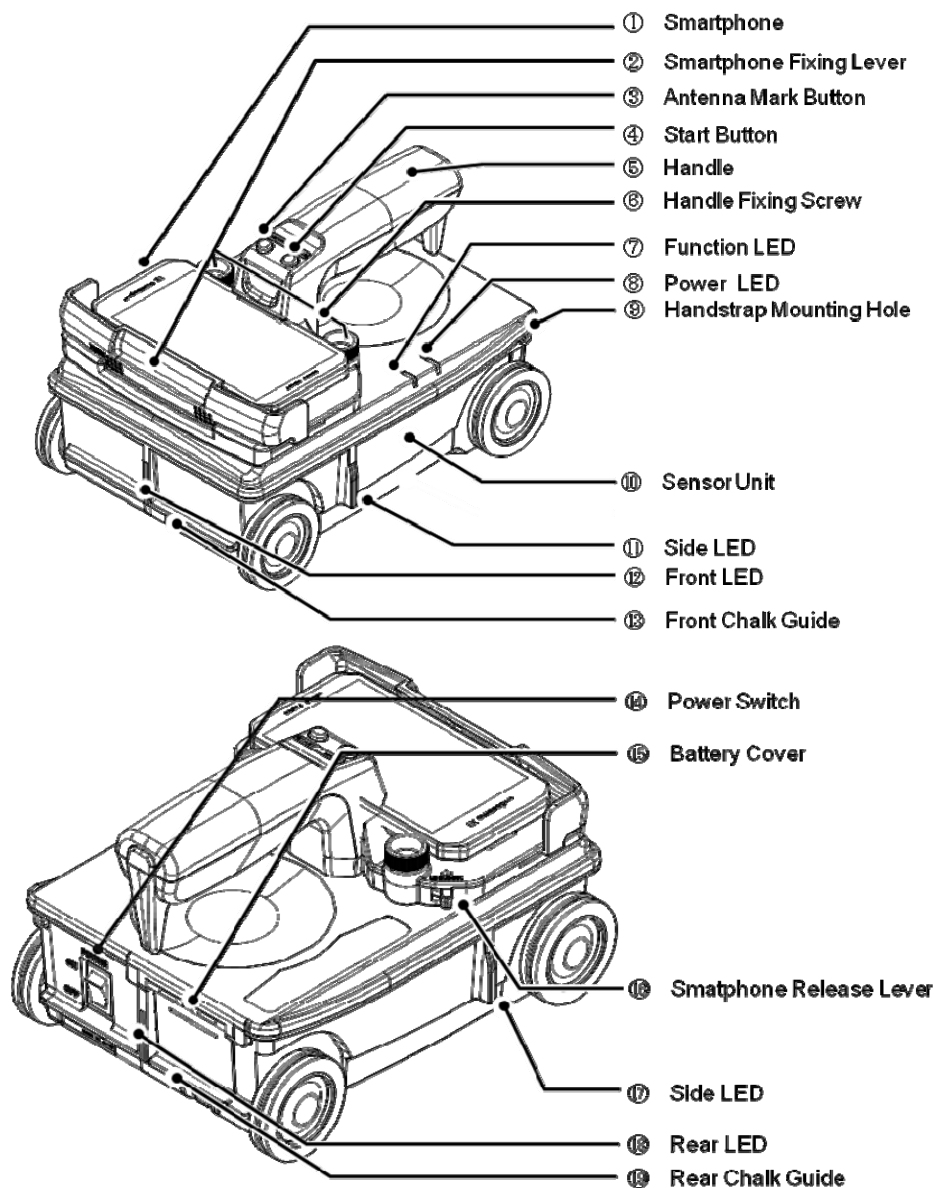

Figure 1-2 Name and function of each part

**Table 1-4 Name and function of each part (1/2)**

Ref	Name	Function
①	<b>Smartphone</b>	Controls the sensor unit (⑩) and displays the scan data obtained by the sensor unit on its screen.
②	<b>Smartphone fixing lever</b>	Used to fix Smartphone (①) to the handle (⑤). For more details, refer to Section 2.9 Attachment and detachment of Smartphone.
③	<b>Antenna mark button</b>	Used to enter antenna marks during the scan.
④	<b>Start button</b>	Used to start and stop the scan.
⑤	<b>Handle</b>	Used to fix Smartphone (①) to the sensor unit (⑩) and to move the sensor unit (⑩). It is removable. For more details, refer to Section 2.4 Attachment and detachment of the handle.
⑥	<b>Handle fixing screw</b>	Used to fix the handle (⑤) to the sensor unit (⑩). For more details, refer to Section 2.4 Attachment and detachment of the handle.
⑦	<b>Function LED</b>	Multi-functional LED. It shows the battery capacity at the power on. For more details, refer to Section 3.2 Section Battery capacity check.
⑧	<b>Power LED</b>	Indicates the power state (on/off) of the sensor unit (⑩).
⑨	<b>Handstrap mouting hole</b>	Used to mount the handstrap. For more details, refer to Section 2.5 Attachment of the handstrap.
⑩	<b>Sensor unit</b>	Sensor unit of this product. It is controlled by Smartphone. In scanning, it transmits the electromagnetic wave, receives the wave reflected from the embedded object, then sends detected data to Smartphone..
⑪ ⑰	<b>Side LED</b>	Indicates the position of the sensor unit being superposing on the specific location (the position of a marker or an antenna mark). Also it is used to align the position (center of the built-in antenna) of the sensor unit with the start line (orthogonal for the scan line).
⑫ ⑱	<b>Front LED Rear LED</b>	Indicates the position of the sensor unit being superposing on the specific location (the position of a marker or an antenna mark). Also it is used to align the position (center of the built-in antenna) of the sensor unit with the scan line.
⑭	<b>Power switch</b>	Power switch of the sensor unit.

**Table 1-4 Name and functions of each part (2/2)**

Ref	Name	Function
⑮	<b>Battery cover</b>	Battery cover of the sensor unit. For more details, refer to Sections 2.6 Attachment of the battery pack and 2.7 Detachment of the battery pack.
⑯	<b>Smartphone release lever</b>	Lever used to remove Smartphone from the handle (⑤). It can release Smartphone fixing lever (②). For more details, refer to Section 2.9 Attachment and detachment of Smartphone.
⑰	<b>Rear chalk guide</b>	Chalk guide used to mark the rebar position when scanning forward. For more details, refer to Section 6.2 Procedure to mark the rebar.
⑱	<b>Front chalk guide</b>	Chalk guide used to mark the rebar position when scanning backward. For more details, refer to Section 6.2 Procedure to mark the rebar.

## **2. Preparation before starting to use**

This section describes the preparation before starting to use this product.

This product uses a Smartphone as the control display, so that it requires the preparation of the Smartphone before starting to use. As the preparation related with Smartphone, you need to install the control software NJJ-200 application into Smartphone and to complete the communication setup between Smartphone and the sensor unit.

NJJ-200 application installation is executed by copying NJJ-200 application file from PC to Smartphone and installing NJJ-200 application as an external application software into Smartphone. The procedure depends on Smartphone model. This section describes the general procedure most common for Smartphone. If the procedure provided in this section is not matched with Smartphone used, install NJJ-200 application into Smartphone by referring to the manual of the Smartphone used.

### **2.1. Overview of preparation**

The preparation consists of the following steps.

- (1) Install NJJ-200 application into Smartphone. For the detailed procedure, refer to Section 2.2 NJJ-200 application installation.
- (2) Set the language for the Smartphone. For the detailed procedure, refer to Section 2.3 Smartphone language setup.
- (3) Attach the handle to the sensor unit. For the detailed procedure, refer to Section 2.4 Attachment and detachment of the handle.
- (4) Attach the handstrap to the sensor unit. For the detailed procedure, refer to Section 2.5 Attachment of the handstrap.
- (5) Attach the battery pack to the sensor unit. For the detailed procedure, refer to Section 2.6 Attachment of the battery pack.
- (6) Set the communication setup between Smartphone and the sensor unit. For the detailed procedure, refer to Section 2.8 Communication setup.
- (7) Attach Smartphone to the sensor unit. For the detailed procedure, refer to Section 2.9 Attachment and detachment of Smartphone.



## 2.2. NJJ-200 application installation

Install NJJ-200 application into Smartphone with the following procedure.

- (1) Copy NJJ-200 application file from PC to Smartphone with the following procedure.  
NJJ-200 application file is provided in the CD-R attached to this product.

By connecting Smartphone and a PC by using a USB cable (or a micro USB cable), Smartphone can be recognized and mounted as a removal data drive on the PC, then the file copy operation of drag and drop become available. By using this capability, copy NJJ-200 application from the PC to Smartphone.

- a) On Smartphone, enable the file operation on Smartphone's memory card from the PC by setting Smartphone into **Card reader mode** or **File transfer mode (MSC)**. For the detailed procedure, refer to the manual attached to Smartphone.  
Example: Tap [**Setting**], [**Device setting**], [**External Connection**], [**USB Connection**], then [**Card reader mode**].
- b) Connect Smartphone to a USB port of the PC by using a micro USB cable.
- c) On Smartphone, tap [**Turn on USB Storage**].
- d) On the PC, Confirm that Smartphone's data storage is recognized and mounted as a removal data drive on the PC.
- e) Create the folder "NJJ200" in Smartphone data drive mounted in steps above.
- f) Insert the furnished CD-R into the CD-R Drive of the PC.
- g) Copy NJJ-200 application file (File name: "NJJ-200.apk") on the CD-R to the folder "NJJ200" on Smartphone by using the drag and drop capability.
- h) Remove the drive of Smartphone from the PC by using the PC function of the safety hardware removal.
- i) On Smartphone, tap [**Turn off USB storage**].

- (2) Install NJJ-200 application into Smartphone with the following procedure.
- a) At the security setting in Smartphone, set the setting so as to allow the installation of applications from the unknown sources. For the detailed procedure, refer to the manual attached to Smartphone.  
Example: Tap **[Setting]**, **[Device setting]**, **[Lock & Security]**, and tap **[Unknown source]**.
  - b) Activate the file management application (**Contents manager**, **File commander**, etc.) in Smartphone. Then install NJJ-200 application by tapping **[NJJ-200]** which was copied into the memory card of Smartphone.

Make sure **[NJJ-200]** icon is registered in **[Downloaded]** at **[Application]** screen on Smartphone. If the icon is not registered, check if steps (1) and (2) above have been done correctly. Figure 2-1 shows an example of NJJ-200 application installation procedure.

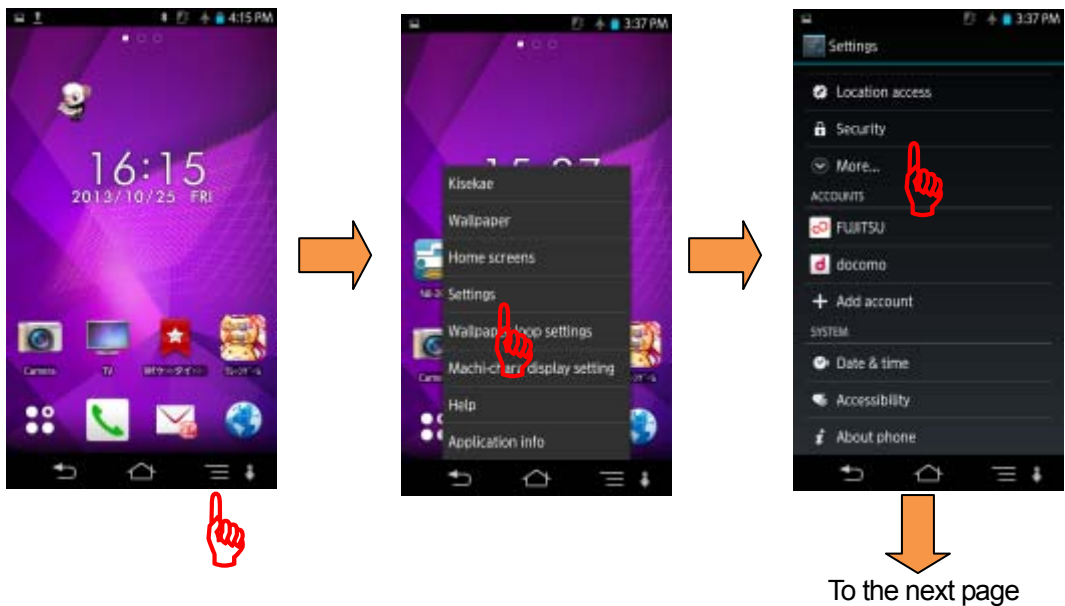
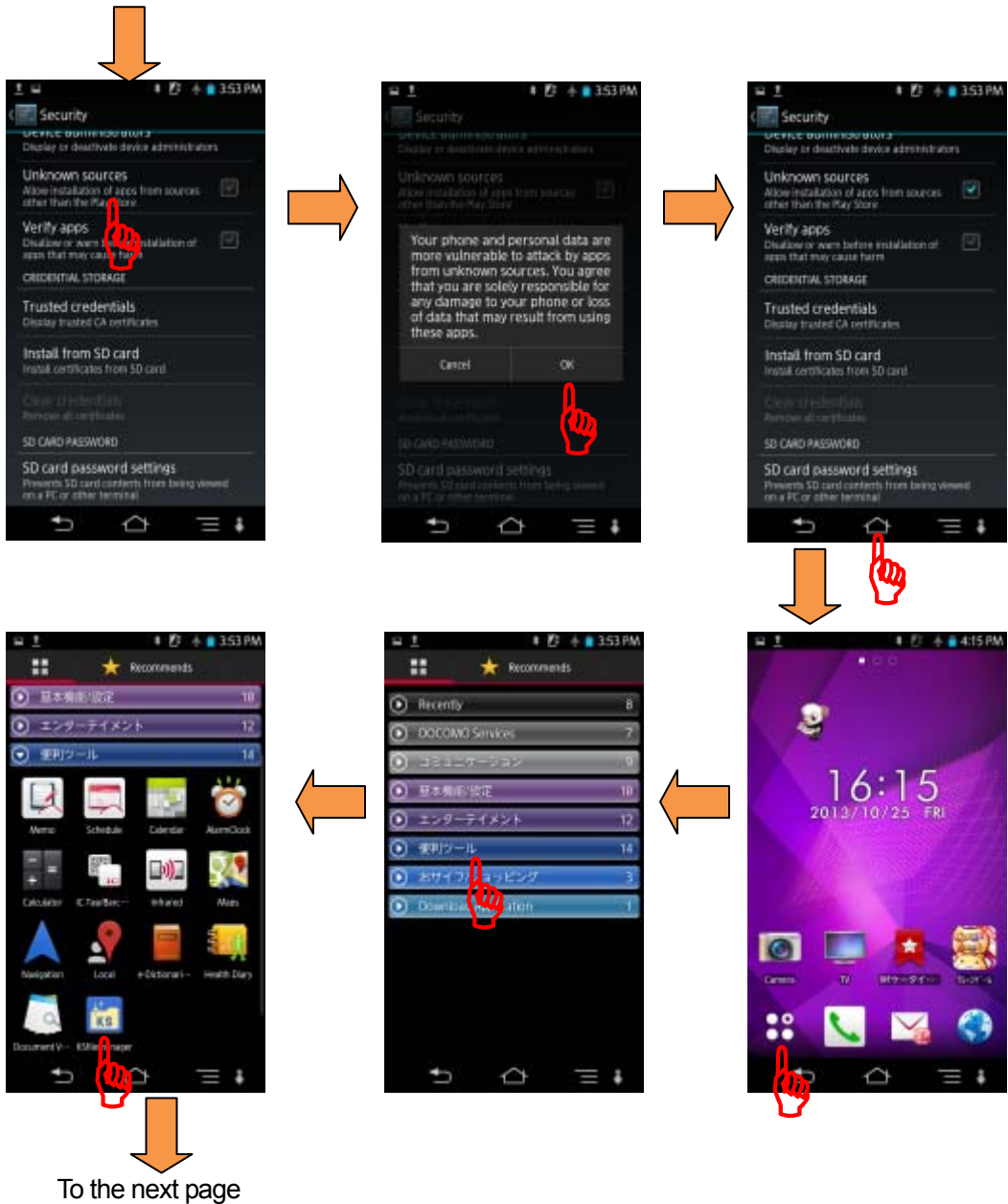

Figure 2-1 NJJ-200 application installation (1/4)

From the previous page



To the next page

Figure 2-1 NJJ-200 application installation (2/4)

From the previous page

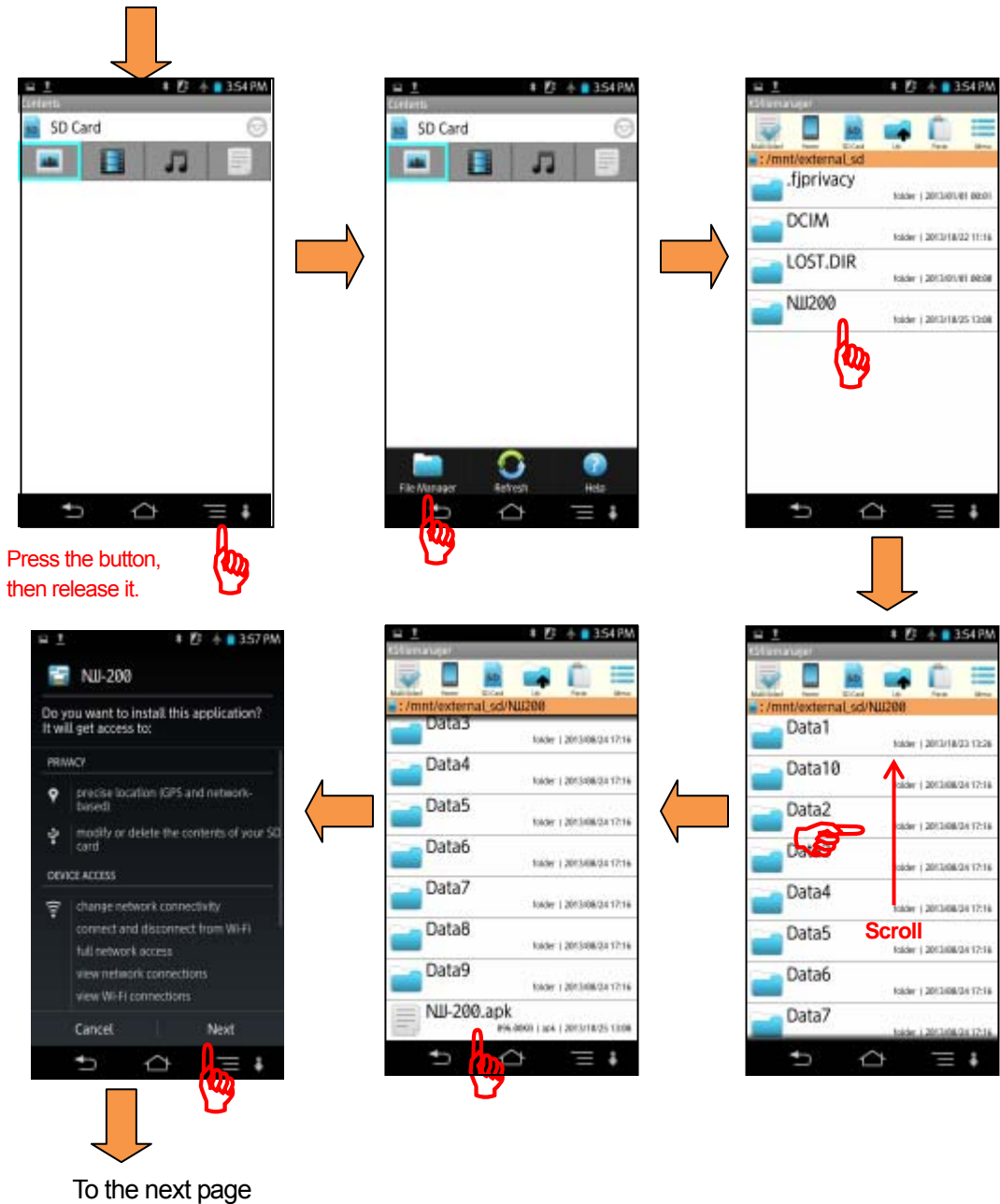

Figure 2-1 NJJ-200 application installation (3/4)

From the previous page

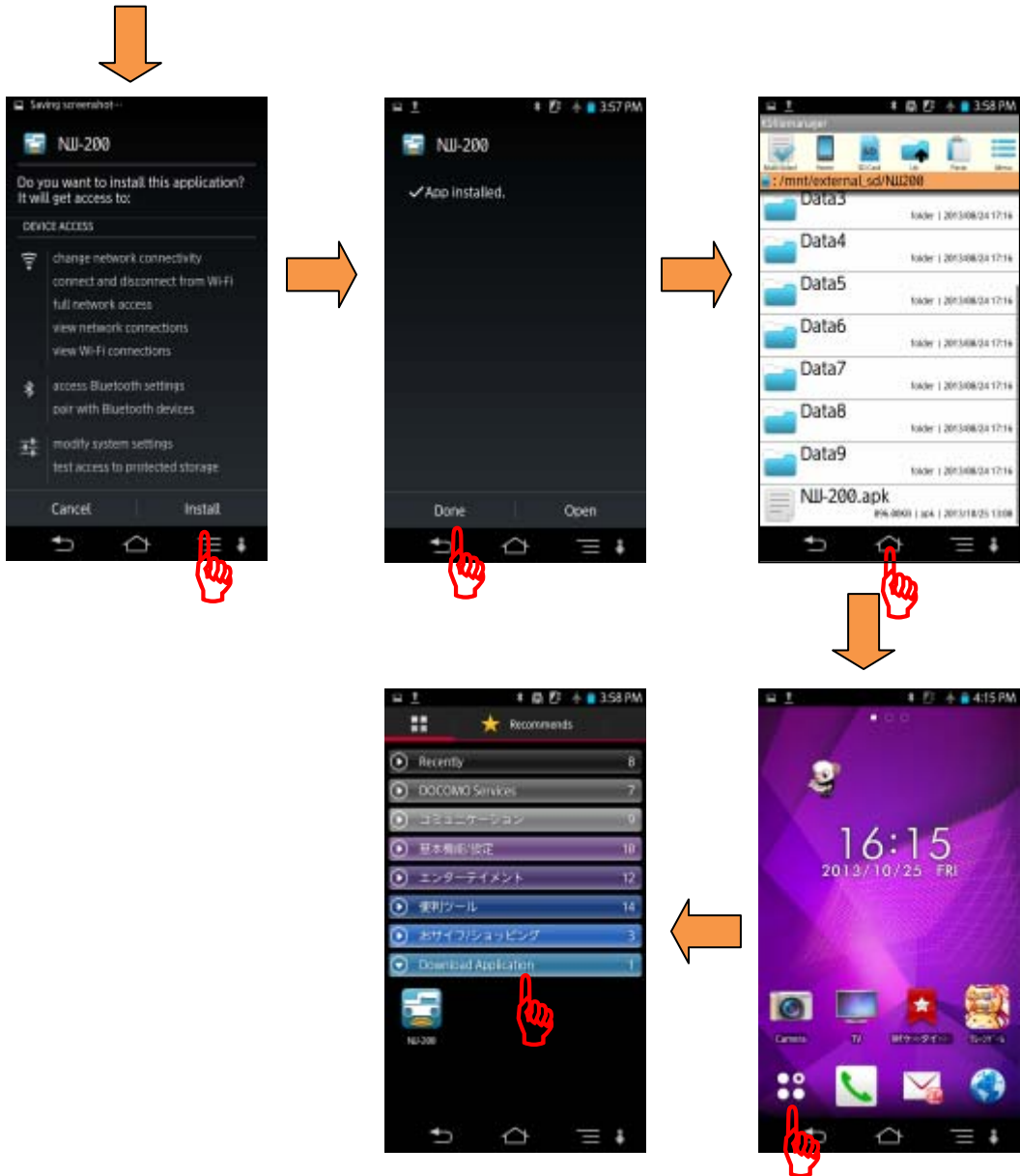

Figure 2-1 NJJ-200 application installation (4/4)

(1) NJJ-200 application operational verification

Make sure that NJJ-200 application is properly installed in Smartphone by the following procedures (Refer to Figure 2-2). If it displays the main screen of NJJ-200 application, the installation is completed successfully.

- a) Turn on Smartphone. Wait a little, then the home screen of Smartphone appears.
- b) Tap **[Application]** icon in the home screen of Smartphone.
- c) Tap **[NJJ-200]** icon shown in **[Download Application]** to run NJJ-200 application.

Then an opening screen of NJJ-200 application appears as shown, then the main screen of NJJ-200 application appears.



Figure 2-2 NJJ-200 application boot-up screen

## 2.3. Smartphone language setup

Switching the language of NJJ-200 application is made by the language setting in Smartphone. Set the language of your choice to Smartphone by referring to the Smartphone manual. NJJ-200 application supports Japanese and English. If other languages are chosen, English is selected in NJJ-200 application..

## 2.4. Attachment and detachment of the handle

The handle is attachable to and detachable from the sensor unit. The attachment and detachment procedure are provided below.

### (1) Detachment of the handle

Rotate the handle fixing screw counterclockwise. Remove the handle by pulling it toward the rear and upward.

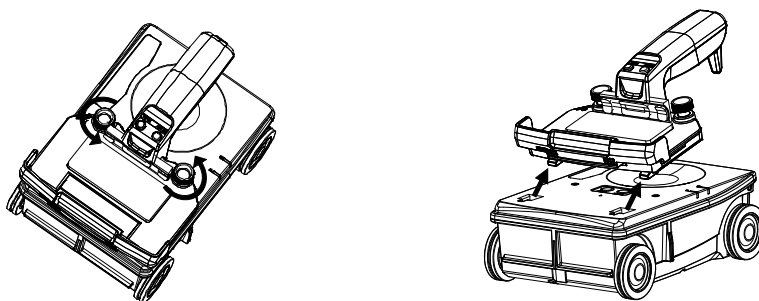

Figure 2-3 Detachment of the handle

### (2) Attachment of the handle

Align and insert two hooks located at the front back plain of the handle into holes located at the front top of the sensor unit. Then rotate the handle fixing screw clockwise and tighten the screw.

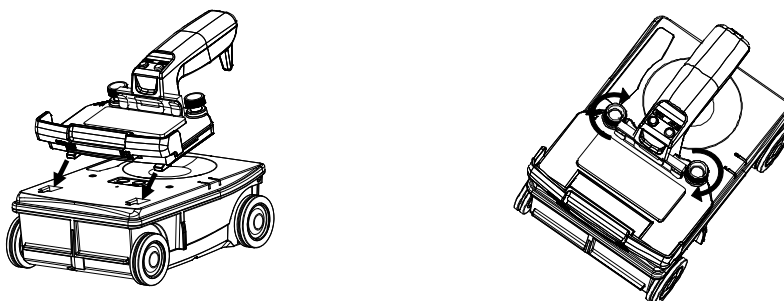

Figure 2-4 Attachment of the handle

## 2.5. Attachment of the handstrap

A handstrap is furnished to the sensor unit as the standard accessory to prevent the accidental dropping of the sensor unit. Attach the handstrap as shown in Figure 2-5 before starting to use this product, and make sure to apply the handstrap to your wrist when operating this product

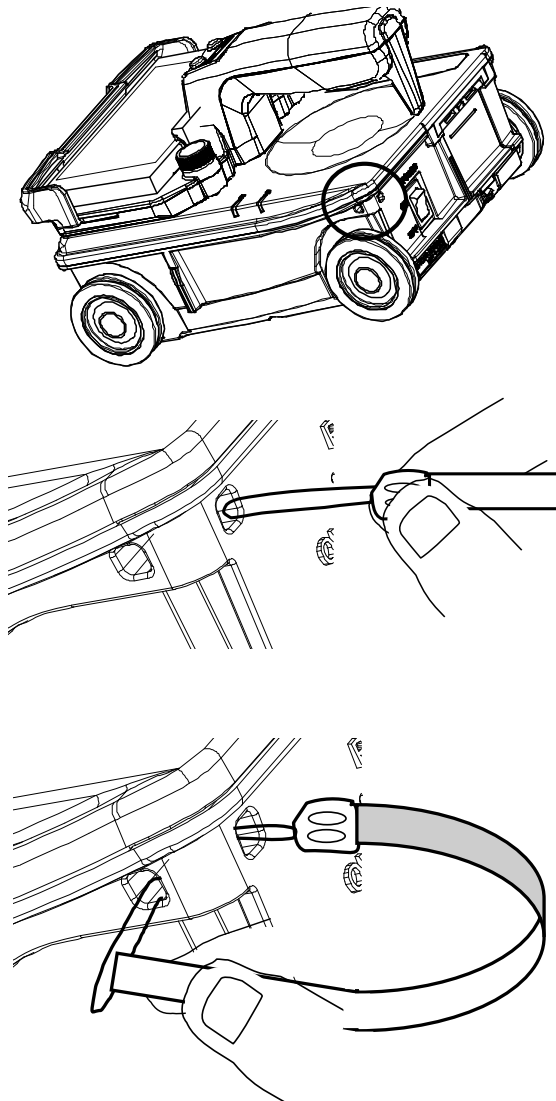

Figure 2-5 Attachment of the handstrap



## 2.6. Attachment of the battery pack

This product supports only the battery pack as its power source. Attach the battery pack into the sensor unit in accordance with the following steps.

- (1) Make sure that the power switch (Figure 1-2 ⑭) is in **OFF** position.
- (2) Open the battery cover by pushing up the locking tab located on the lower part of the battery cover (Figure 1-2 ⑮).
- (3) Insert the battery pack pin side first until it locks into place. (You should hear a “click” when it locks into place.) Close the battery cover.

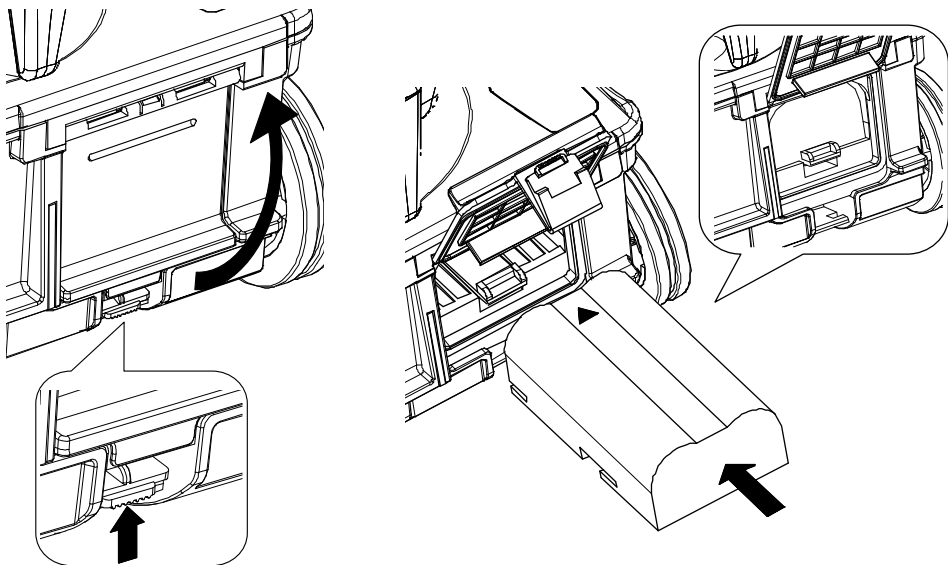

Figure 2-6 Attachment of the battery pack

### Note

- Always confirm that the power switch is turned to **OFF** position before installing or removing the battery pack.

## 2.7. Detachment of the battery pack

When removing the battery pack, perform the following steps.

- (1) Make sure that the power switch is in **OFF** position.
- (2) Open the battery cover by pushing up the lock tab located on the lower part of the battery cover.
- (3) Press down the battery pack release button. Then the battery will be pushed out. Remove the battery pack from the sensor unit. Be careful so as not to drop the battery.
- (4) Close the battery cover.

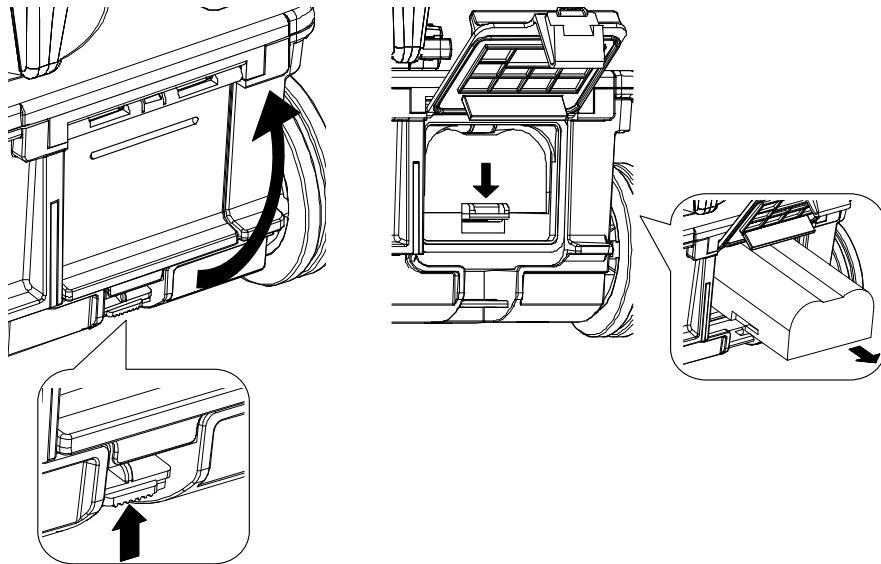

Figure 2-7 Detachment of the battery pack

### Caution

- When safekeeping this product for a long term, make sure to detach the battery pack from the sensor unit. If this product is left in the incorrect state for a long time where the battery pack is not attached fully and the battery pack release button is pushed down by the battery pack, the battery pack release button may be damaged and become difficult to be locked due to its shape change.

## 2.8. Communication setup

Use the following procedure to establish the communication between the sensor unit and Smartphone through wireless LAN.

- (1) Make sure the battery pack is installed and the sensor unit is switched to **ON** position.
- (2) Turn on Smartphone. Home screen of Smartphone will appear after a while.
- (3) Set Smartphone to **Airplane mode**.
- (4) Tap **[Application]** icon on the home screen.
- (5) Tap **[NJJ-200]** icon in **[Downloaded application]**. Then the opening screen of NJJ-200 application appears and shows the main screen automatically.
- (6) Long tap **[Parameter]** icon. Then the parameter setup screen appears.
- (7) Tap **[Sensor select]** menu in the parameter setup screen. Then the sensor select screen appears and lists sensor units available nearby Smartphone.
- (8) Tap the ID of the used sensor unit in the sensor select screen.
- (9) Return to the main screen. Then the communication between Smartphone and the sensor unit is established, and the antenna icon turns from red to green and the color of the sensor unit's power LED changes from red to green.

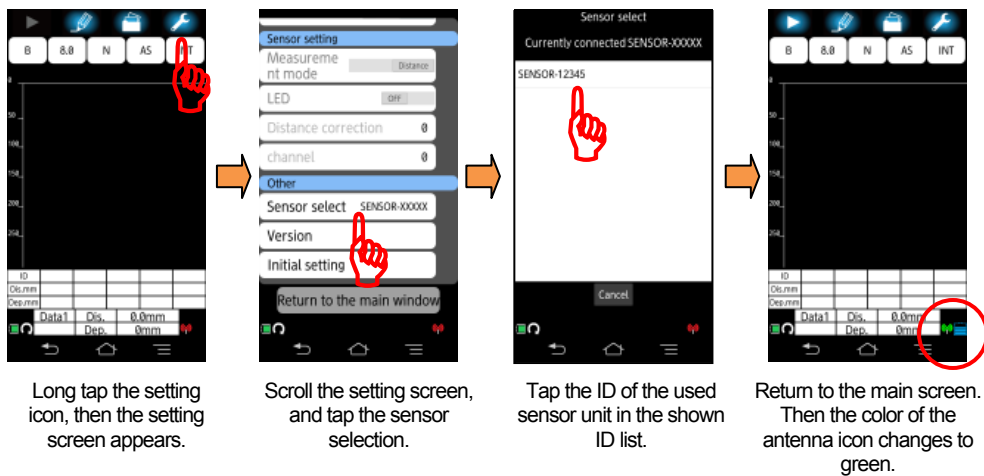

**Figure 2-8 Communication setup**

**Notes on wireless communication:**

- Some devices operate using the same frequency bands adopted by this product. Equipment such as microwave ovens and other home electronics, radios and equipment used in various types of radio stations including Amateur Radio stations, and devices that operate on industrial, scientific, or medical frequency bands may experience interference from this product.
- In case any harmful radio interference occurred, immediately stop to use this product. Then contact to one of our contact points described in Section 14 or the distributor from which you purchased this product to get consultation about the solution.

**Caution**

- Make sure that Smartphone is set to **Airplane mode:ON**. If NJJ-200 application is started on Smartphone with **Airplane mode:OFF**, a message “Could not be set to airplane mode.” appears. If such a messages appears, tap the **[OK]**, then stop NJJ-200 application. Set Smartphone to be in **Airplane mode**, then restart NJJ-200 application.
- Use this product in the area of small electrical and magnetic noise. Otherwise , especially when using near a microwave oven, this product may be influenced by magnetic or electrical noise, resulting noise level increased in the scan result or unstable communication between the sensor unit and Smartphone.
- If used near TV or radio, harmful interference (including TV image distortion) may occur.
- If the same channel is used by nearby wireless LAN access points, NJJ-200 application may not detect available sensor units correctly. In such case, change the communication channel by referring to Section 6.7 Communication channel setup.

**Note**

- The digits following “SENSOR-“ in the sensor unit’s ID number displayed on the sensor select screen corresponds with the last 5 digits in the serial number of the sensor unit.
- Once Smart phone establishes the communication with the sensor unit, the ID of the the sensor unit is registered as the present connection destination. From the next boot up, NJJ-200 application establishes the communication with the registered sensor unit automatically. When you want to connect with other sensor unit, choose the desired ID of the sensor unit on a sensor select screen.
- The communication between Smartphone and the sensor unit is made at one by one. When Smartphone has established the communication already with a sensor unit, the other Smartphone cannot communicate with the sensor unit.
- When two or more sensor units are near Smartphone, the sensor select screen displays all ID numbers of sensor units nearby Smartphone. Choose a ID number including the serial number of the used sensor unit, then you can establish the communication with the used sensor unit.

## 2.9. Attachment and detachment of Smartphone

Smartphone is put on the handle and fixed by Smartphone fixing lever of the handle. When attaching Smartphone on the handle, make sure first to release completely Smartphone fixing lever, then place Smartphone on the handle. For the detachment procedure of Smartphone, refer to the following (2) .

### (1) Attachment Procedure

Place Smartphone at the front part of the handle. Then push and slide Smartphone fixing lever located at the front end of the handle to lock Smartphone.

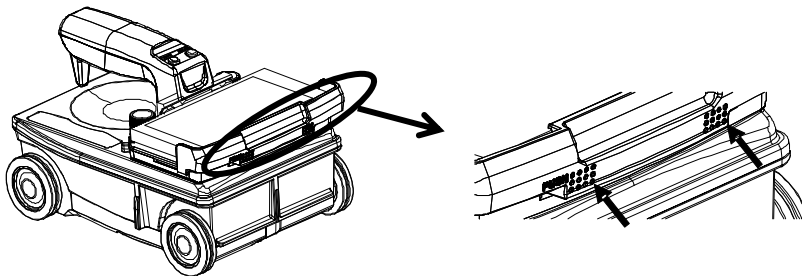

Figure 2-9 Attachment of Smartphone

### (2) Detachment

Push the lock lever located at the side of the handle toward the direction shown by the label "Unlock", then release Smartphone fixing lever completely. After confirming the lever released completely, remove Smartphone from the handle.

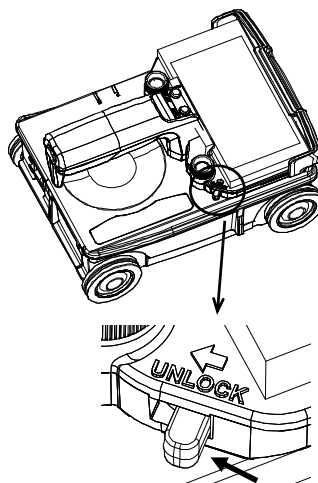











Figure 2-10 Detachment of Smartphone









### 3. Basic scan procedure

This section describes the basic scan procedure. The following description assumes all the preparations described in Section 2 have been completed successfully. If some preparations have not been made yet, complete all the preparations in accordance with Section 2. In the following description, each icon or button displayed in NJJ-200 application is referred by using **[its name]**.

 <b>WARNING</b>	
	Do not use any battery pack other than the recommended battery packs. Doing so could cause fire, electric shock, or breakdown.
	Do not short-circuit the terminals of the battery charger or battery pack. Doing so could cause fire, explosion, or breakdown.
	Do not insert anything metallic or flammable into the battery pack slot. Doing so could cause a personal injury, fire, electric shock, or breakdown.
	Do not use any charger other than the dedicated battery charger to charge the battery pack. Doing so could cause fire, electric shock, or breakdown.
	Do not use (place) this product in a location where it is exposed to flammable or corrosive gas. Doing so could cause fire, personal injury, or breakdown.
	Handy Search has a waterproof construction but must not be placed in water. Do not expose this product to water or moisture, and do not use it in rainy weather. Doing so could cause an electric shock or breakdown.

 <b>CAUTION</b>	
	Making a judgment on the scan results considers the depth scan capability of this product. Since the depth scan capability of this product is subject to the conditions of the object of investigation, judging the scan results with no consideration of the depth scan capability may cause the cutting of rebars.
	Put your hand through the hand strap and hold this product. Dropping of this product may cause an accident such as a device breakdown or personal injury.

## CAUTION

	Point the antenna surface in the direction of the probed object (concrete) while you are performing a probe. If it is pointed into the air or otherwise unsuitable direction, it can cause malfunction of other equipment or other such accidents.
	Do not place this product on an unstable place such as a wobbly table or sloping surface. Doing so may cause a personal injury or breakdown when it drops or falls.
	Do not use (place) this product in a humid or dusty location, or a location where water, oil, or chemical may splash onto this product. Doing so may cause fire, electric shock, or breakdown.
	Do not use (place) this product in a location where it is subject to vibration or shock. Doing so may cause a personal injury or breakdown.
	When loading/unloading printing paper, be careful not to cut or jam your fingers in the printer. Otherwise a personal injury, accident, or breakdown may be caused.
	Do not use this product in the vicinity of a radio or TV set. Doing so may cause noise or poor reception such as disturbance of television pictures. Doing so also adversely affects the depth sensing capability of this product, and may cause the cutting of rebars.
	Do not use this product near a transceiver that transmits electromagnetic waves. Electromagnetic waves from the transceiver adversely affect the depth sensing capability of this product, and may cause the cutting of rebars.
	When this product is used for scanning on the road, take safety precautions such as providing guard fences to prevent traffic accidents.



### 3.1. Preparation for scanning lines

Mark the start line and scanning line by using a chalk (or similar) on the concrete surface to indicate where to start scanning (starting line) and where to scan (scanning line). Make sure the start line and the scanning line are orthogonal. As necessary, in order to perform a re-scan, use the end point of the wall as the reference point for the start line and scanning line. An example for scanning line is shown in Figure 3-1.

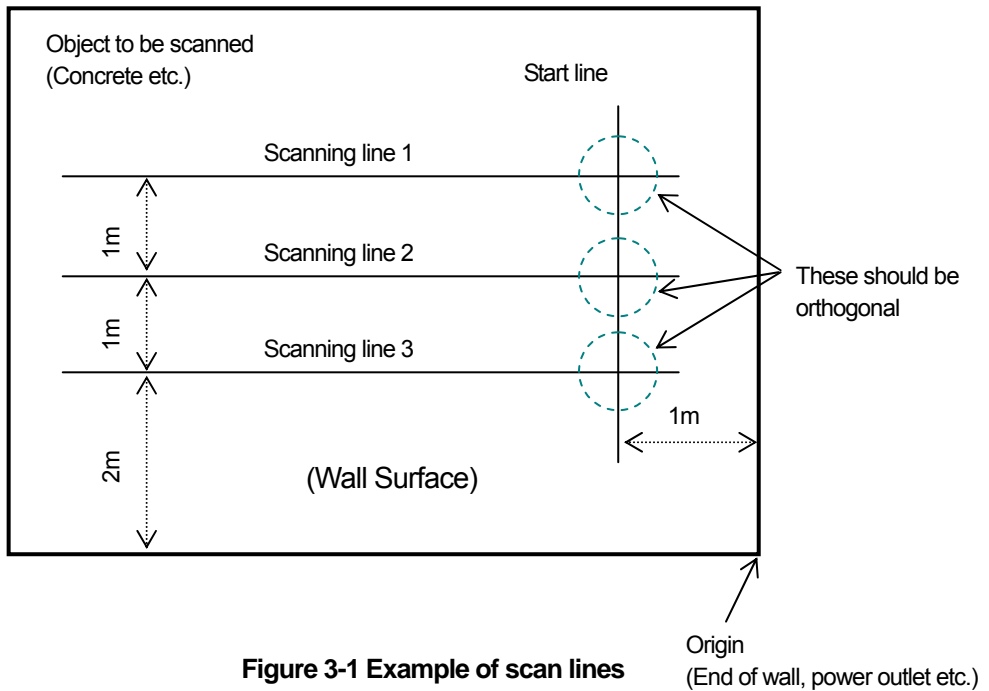

Figure 3-1 Example of scan lines

### 3.2. Battery capacity check

Confirm that batteries attached into Smartphone and NJJ-200 sensor unit are sufficiently charged with the following procedure.

(1) Smartphone battery capacity

NJJ-200 application indicates the battery capacity of Smartphone on the left bottom of the main screen after the boot-up. (Refer to Figure 4-1 ⑬.) Figure 3-2 shows the remained capacity of the battery shown by each indication.

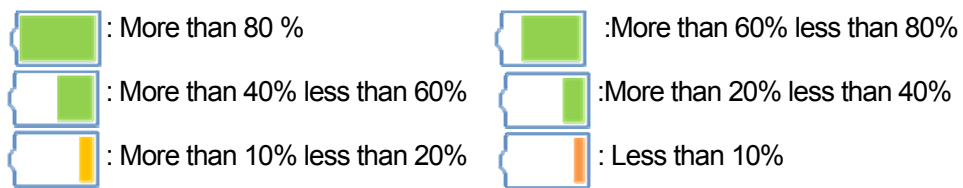

**Figure 3-2 Smartphone battery capacity Indication**

(2) Sensor unit battery capacity

The battery capacity of the sensor unit can be checked by the LED state after turning on the sensor unit. For the procedure to confirm the battery capacity by LED state, refer to the following a). And NJJ-200 application indicates the remained capacity after starting the communication between Smartphone and the sensor unit. For the procedure, refer to the following b).

a) When turning on the sensor unit

After the sensor unit turned on, the function LED blinks and shows the remained capacity of the sensor unit's battery as shown in Table 3-1.

**Table 3-1 Sensor Unit Battery Capacity Indication by Function LED**

Remained Capacity	Numbers of LED Flashes
More than 75 %	4 flashes repeated 3 times
More than 50 % less than 75 %	3 flashes repeated 3 times
More than 25 % less than 50 %	2 flashes repeated 3 times
Less than 25 %	1 flash repeated 3 times
None	No flash

b) When starting the communication between Smartphone and the sensor unit NJJ-200 application shows the remained capacity of the sensor unit's battery after starting the communication between Smartphone and the sensor unit. Figure 3-3 shows the remained capacity of the battery shown by each indication.

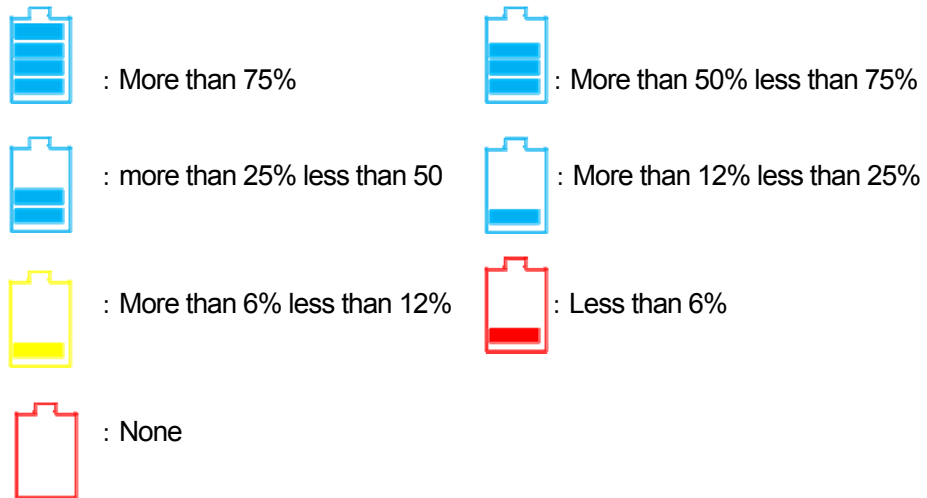

**Figure 3-3 Sensor Unit Battery Capacity Indication**

**Note**

- This product supports only the battery as its power source.
- The continuous operation time for the fully charged battery is approx. 7 hours. The time depends on the operation content. When the continuous operation time is forecasted beyond 7 hours, the preparation of a second battery is recommended.

### 3.3. Scanning

Perform the scan with the following procedure.

(1) **Confirm all settings of the product.**

The settings to be confirmed are **[Display mode]** (B/BA) , **[Measurement mode]** (Distance/Time), **[Color]** (Absolute /Offset), **[Relative permittivity]**, and **[Sensitivity]**. For the setting procedure, refer to Section 4 NJJ-200 application functions. When the location of the embedded steel bar is known or the width of concrete is known, perform the depth calibration in accordance with Section 6.1 Relative permittivity setup.

(2) **Place this product on the start line.**

The position to be sensed is the cross point of the line between both side LEDs (Refer to Figure 1-2 ⑪ and ⑰.) and the line between the front and rear LEDs (Refer to Figure 2-1 ⑫ and ⑱). Place the sensor unit so as to superpose the line between both side LEDs on the start line (Refer to Figure 3-1) and to superpose the line between the front and rear LEDs on the scanning line (Refer to Figure 3-1).

(3) **Start the scan.**

Tap **[Start]** icon (Refer to Figure 4-1 ① ) on the main screen of Smartphone, or press **[Start]** button (Refer to Figure 1-2 ④) on the sensor unit. After one second, a beep sounds and the fix cursor is displayed on B mode screen.

**Note**

- The scan is automatically stopped when the sensor unit stays at a position more than 8 seconds.

(4) **Move the sensor unit along with the scan line.**

Make sure the moving speed is less than 40cm/s.

**Caution**

- If the speed exceeds beyond 40 cm/s, a beep sounds and the scan becomes invalid. Any scan data are not obtained during this time. If the sounds, stop the scan and re-start the scan (from the step (2) above).

(5) **As necessary, add antenna markers on the scan screen.**

Tap **[Marker]** icon on the main screen or press **[Antenna mark]** button on the sensor unit (Refer to Figure 1-2 ③) to add an antenna mark. When the antenna marker is added, a mark ↓ is displayed on the distance scale. The antenna marker is useful to show the location of the rebar shown in the drawing or the position of the planned drill hole on the scan screen.

- (6) **As necessary, perform the image processing of Real time manual subtraction.** Waves reflected by objects to be probed (e.g., reinforcing steel) at a position near the concrete surface are difficult to identify because they are combined with waves reflected by the concrete surface (called surface waves). This product contains the standard surface wave data (fixed surface wave data) with which it eliminates the influence of the concrete surface waves in real time by subtracting the fixed surface wave from the received reflection signal. By performing this image processing, you can more easily identify the object location. However there are some cases for example, special conditions (very humid surface, lightweight concrete, etc.) of the concrete surface, where subtracting the fixed surface wave cannot remove the influence of the surface wave due to the difference between the fixed surface wave and the actual surface wave. In such case, horizontal lines (noise) may appear near the surface. In this case, you can use the actually received signal as the surface wave in place of the fixed surface wave. The image processing using the actually received surface wave is called real time surface wave processing. The real time surface wave processing can remove the horizontal lines near by the surface. To use the real time surface wave processing, move the fixed cursor to the position where any embedded objects are not detected, then tap **[Image processing]** icon (Figure 4-1 ⑤). (Refer to Figure 3-4.)

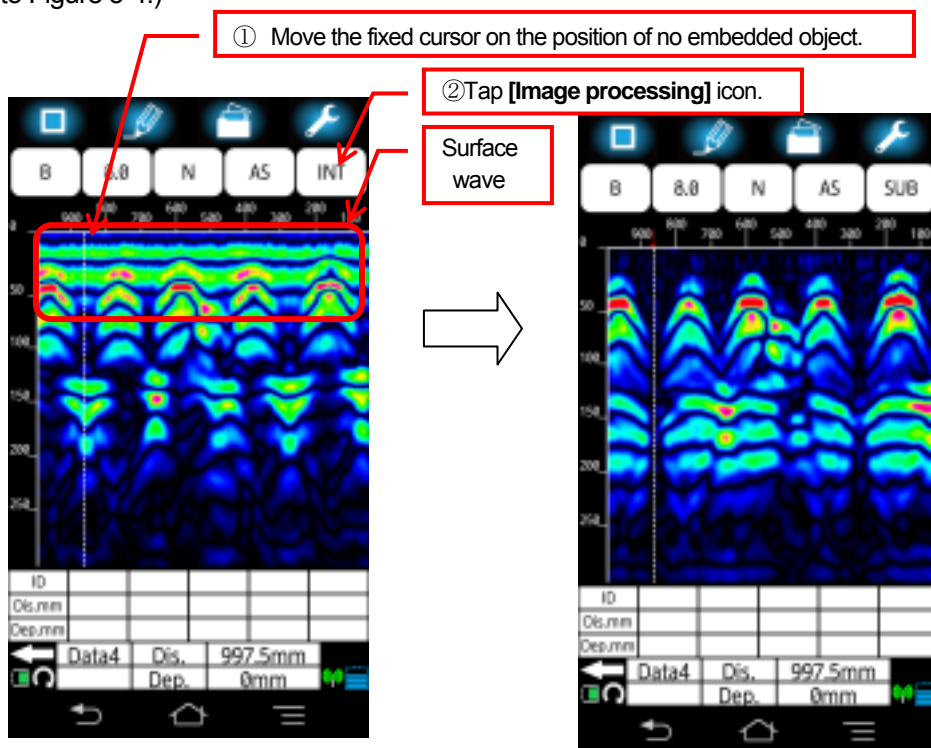

**Figure 3-4 B Mode scan result (during scanning)**

(7) **Stop the scan.**

Tap [**Start**] icon (Refer to Figure 4-1 ①) of the main screen or press [**Start**] button on the sensor unit (Refer to Figure 1-2 ④) to stop the scan. Then a beep sounds twice and the scan is stopped. Figure 3-5 shows an example of the scan result. ([**Start**] icon is displayed as [□] during the scan, and after the scan stopped, its shape changes to [▷].)

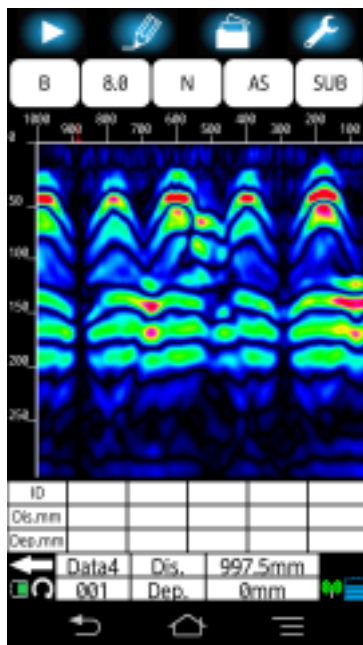

Figure 3-5 Example of B mode scan result

**Note**

- When moving the sensor unit at the speed beyond 40 cm/s, a beep sounds and the scan becomes invalid. No scan data is obtained during this time.
- The final scanned point of B mode data represents the data obtained at the position of the line between both side LEDs (Refer to Figure 1-2 ⑪と⑰) of the sensor unit showing the center of the sensor unit's built-in antenna.
- The scan is automatically stopped when the sensor unit stays at a position more than 8 seconds.

(8) **As necessary, optimize the sensitivity, color, image processing.**

By changing the sensitivity, color, image processing settings, find for the best settings to get the scan result which provide easy identification of the object position.

(9) **Store the data into the file.**

Tap [**File /Print**] icon on the main screen to save the scan data into the file or print out the scan data to the external printer.

### 3.4. Interpreting the scan results

Here describes the general procedure to identify position of the detected object.

When the scan result shown in Figure 3-6 is obtained after the rebar detection, the image of the detected rebar would have the inverse U shape as shown in Figure 3-6. By using this description, you can determine that a rebar is located at the reverse U shape.

The position of the detected object can be determined from the obtained image as described below.

Position of the moving direction: Top of the inverse U shape (See ↓ in Figure 3-6)

Rough Depth (Cover width): Center of the inverse U shape (See ● in Figure 3-6)

To reduce the depth error of the detected object, perform the depth calibration (Refer to Section 4.11.1 Device setting: [Relative permittivity) and identify the depth from A mode wave shown in the BA mode display (Refer to Section 4.6 [Display mode] icon). The depth of the detected object (a rebar, etc.) is matched with the right side peak of A mode wave. You can get the exact depth value by moving the cursor exactly on the peak of the A mode wave.

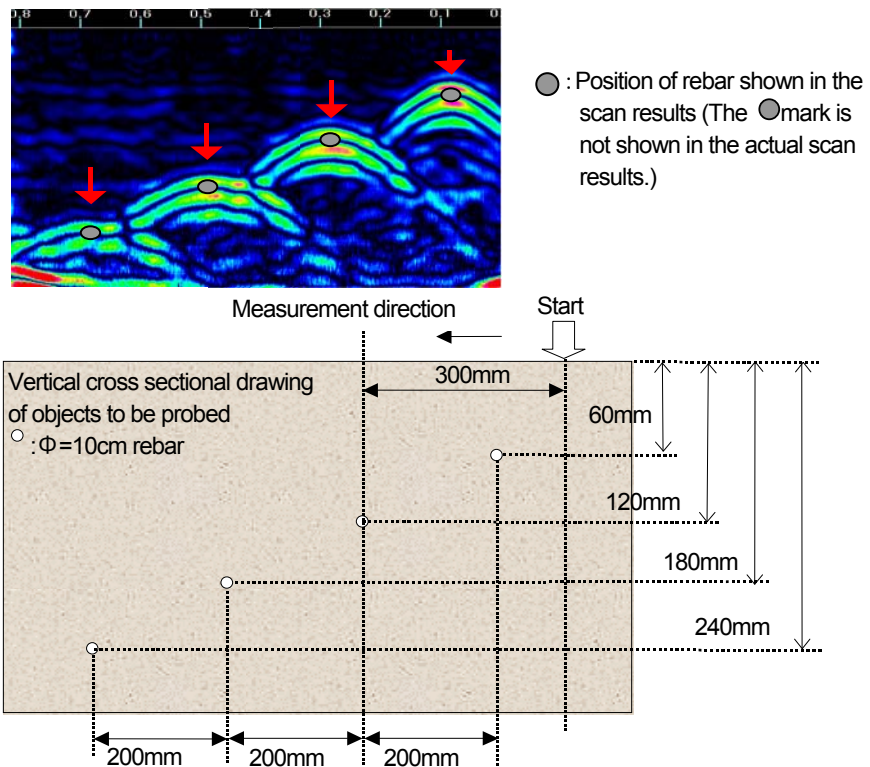

Figure 3-6 Scan result example

### 3.5. Power off

After completing all scan works, turn off NJJ-200 by switching the power switch to the OFF position. For Smartphone, tap Home button of Smartphone to end NJJ-200 application.

#### Caution

- When ending NJJ-200 application without saving the scan result into a file, the scan data disappear.
- When turning off Smartphone display without ending NJJ-200 application, you can get the previous screen of NJJ-200 application by turning on the display.
- When NJJ-200 application is ended during the scan, the scan is ended forcedly.

### 3.6. Shutdown and storage

Make sure to turn off this product after using and put it back into its case.

#### Caution

- When safekeeping this product for a long term, make sure to detach the battery pack from the sensor unit. If this product is left in the incorrect state for a long time where the battery pack is not attached fully and the battery pack release button is pushed down by the battery pack, the battery pack release button may be damaged and become difficult to be locked due to its shape change.

#### Note

- When not using this product for a long time, store this product after removing the battery from the sensor unit.