

JMA-1030Series

MARINE RADAR EQUIPMENT

INSTRUCTION MANUAL

PRECAUTIONS BEFORE OPERATION

■ Cautions for high voltage

High voltages from hundreds volts to tens of thousands volts are to be applied to the electronic equipment such as radio and radar devices. You do not face any danger during normal operation, but sufficient care is required for maintenance, inspection and adjustment of their internal components. (Maintenance, check-up and adjustment of the inside of the equipment are prohibited except by maintenance specialists.) High voltages of tens of thousands volts are so dangerous as to bring a death from electric shock, but even voltages of hundred volts may sometimes lead to a death from electric shock. To prevent such an accident, make it a rule to turn off the power switch, discharge capacitors with a wire surely earthed on one end, make sure that internal parts are no longer charged before you touch any parts inside these devices. At the time, wearing dry cotton gloves ensures you further to prevent such danger. It is also a necessary caution to put one of your hands in the pocket and not to use your both hands at the same time.

It is also important to select a stable foothold always to prevent additional injuries once you were shocked by electricity. If you were injured from electric shock, disinfect the burn sufficiently and get it taken care of promptly.

■ What to do in case of electric shock

When finding a victim of electric shock, turn off the power source and earth the circuit immediately. If it is impossible to turn off the circuit, move the victim away promptly using insulators such as dry wood plate and cloth without touching the victim directly. In case of electric shock, breathing may stop suddenly if current flows to the respiration center in the brain. If the shock is not so strong, artificial respiration may recover breathing. When shocked by electricity, the victim will come to look very bad with weak pulse or without beating, resulting in unconsciousness and rigidity. In this case, it is necessary to perform an emergency measure immediately.

FIRST-AID TREATMENTS

■ First-aid treatments

As far as the victim of electric shock is not in dangerous condition, do not move him and practice artificial respiration on him immediately. Once started, it should be continued rhythmically.

- 1 Do not touch the victim confusedly as a result of the accident, but the rescuer may also get an electric shock.
- 2 Turn off the power source calmly and move the victim away quietly from the electric line.
- 3 Call a physician or ambulance immediately or ask someone to call a doctor.
- 4 Lay the victim on this back and loosen his necktie, clothes, belt, etc.
- 5
 - a. Examine the victim's pulse.
 - b. Examine his heartbeat bringing your ear close to his heart.
 - c. Examine his breathing bringing the back of your hand or your face close to his face.
 - d. Check the size of the pupils of his eyes.
- 6 Open the victim's mouth and take out artificial teeth, cigarette or chewing gum if any. Keep his mouth open, stretch his tongue and insert a towel or the like in his mouth to prevent the tongue from suffocating. (If it is hard to open his mouth due to set teeth, open it with a screwdriver and insert a towel in this mouth.)
- 7 Then, wipe his mouth so that foaming mucus does not accumulate inside.

■When pulse is beating but breathing has stopped

(Mouth-to-mouth respiration) Fig. 1

- 1 Tilt the victim's head back as far as this face looks back. (A pillow may be inserted his neck.)
- 2 Push his jaw upward to open his throat wide (to spread his airway).
- 3 Pinch the victim's nostrils and take a deep breath, block his mouth completely with yours and blow into his mouth strongly. Take a deep breath again and blow into his mouth.
Continue this 10 to 15 times a minutes (blocking his nostrils).
- 4 Carefully watch that he has recovered his natural breathing and atop practicing artificial respiration.
- 5 If it is difficult to open the victim's mouth, insert a rubber or vinyl tube into one of his nostrils and blow into it blocking the other nostril and his mouth completely.
- 6 When the victim recovers consciousness, he may try to stand up suddenly, but let him lie calmly and serve him with a cup of hot coffee or tea and keep him warm and quiet. (Never give him alcoholic drinks.)

●Method of mouth-to-mouth respiration by raising head

Fig. 1 Mouth-to mouth respiration

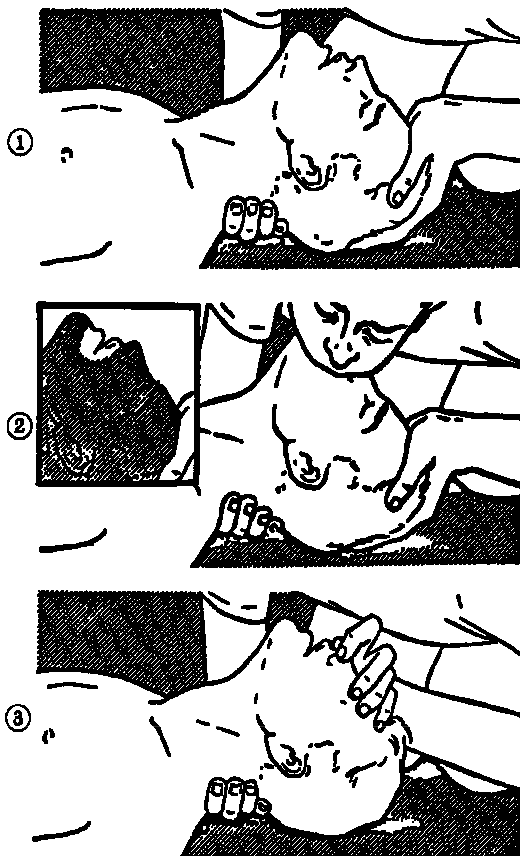

- (1) Raise the victim's head. Support his forehead with one of your hand and his neck with the other hand. →①
When you tilt his head backward, the victim, in most cases, opens his mouth to the air. This makes mouth-to mouth respiration easy.
- (2) Cover his mouth as widely as possible with yours and press your cheek against his nose→②
Or, pinch his nostrils with your fingers to prevent air from leaking. →③
- (3) Blow into his lungs. Continue blowing into his mouth until his breast swells. Blow into his mouth as quickly as possible for the first 10 times.

■When both pulse and breathing have stopped

Perform the (Cardiac massage) Fig. 2 and (Mouth-to-mouth respiration) Fig. 1

When no pulse has come not to be felt, his pupils are open and no heartbeat is heard, cardiac arrest is supposed to have occurred and artificial respiration must be performed.

- 1 Place your both hands, one hand on the other, on the lower one third area of his breastbone and compress his breast with your elbows applying your weight on his breast so that it is dented about 2cm (Repeat compressing his breast 50 times or so a minutes). (Cardiac massage)
- 2 In case of one rescuer, Repeat cardiac massages about 15 times and blow into his mouth 2 times quickly, and repeat this combination.
In case of two rescuers, one person repeats cardiac massages 15 times while the other person blow into his mouth twice, and they shall repeat this combination. (Perform the cardiac massage and mouth-to-mouth respiration)
- 3 Examine his pupils and his pulse sometimes. When the both have returned to normal, stop the artificial respiration, serve him with a cup of hot coffee or tea and keep him warm and calm while watching him carefully. (Never give him alcoholic drinks.) Commit the victim to a medical specialist depending on his condition. To let him recover from the mental shock, it is necessary for persons concerned to understand his situations and the necessary treatment.

Fig. 2 Cardiac massage

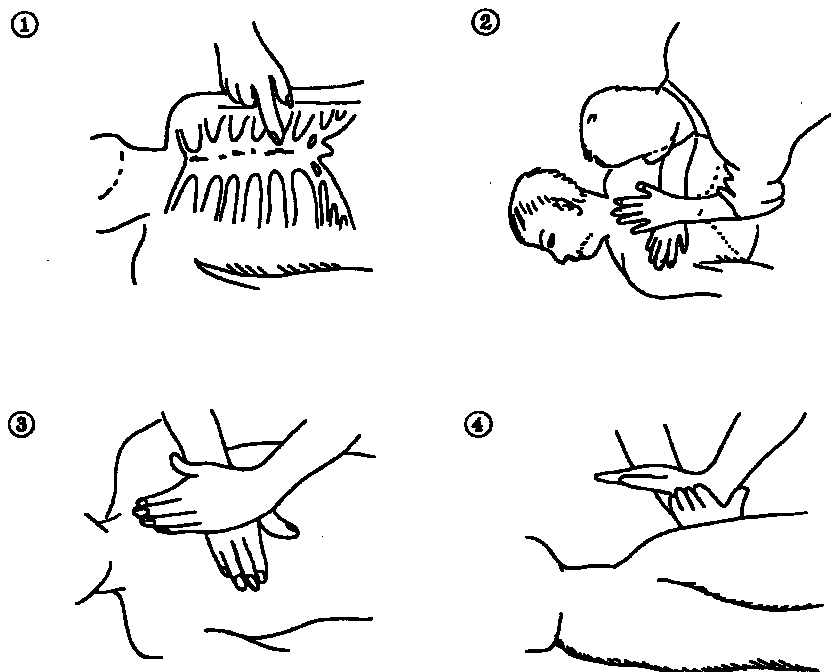

PREFACE

Thank you very much for purchasing the JRC marine radar equipment, JMA-1030 series. This equipment is a marine radar equipment designed to obtain safe operation of marine ships. This equipment consists of a scanner unit and a display unit as its main units.

- Before operating the equipment, be sure to read this instruction manual carefully for correct operation.
- Maintain this instruction manual so that operators can refer to it at anytime. Refer to this manual when any inconvenience or defect occurs.
- In this equipment manual, contains easy operational bridge card on appendix page. Please copy it and equip them around the set.

About equipment type names:

JMA-1030 is a radar series model name.

Individual name is changes according to the combination of units.

JMA-1030 Series

JMA-1032  Display NCD-2256 + Scanner NKE-1066

JMA-1034  Display NCD-2256 + Scanner NKE-2044

CHECKING THE SUPPLIED ITEMS

STANDARD SUPPLY ITEMS

Standard supply items are as follows.

The normal installation cable length is 10m between scanner and display.

Optional special length cables are prepared by JRC if request.

Standard cable length is 10m.

Optional special length cables are 5m, 15m, 20m 30m each.

(Please order if necessary)

SCANNER UNIT 1 set

DISPLAY UNIT 1 set

LCD DISPLAY COVER 1Piece

INSTALLATION CABLE (SCANNR TO DISPLAY) 1Piece (Standard 10m)

POWER SUPPLY CABLE (DC input cable 2m) 1Piece

STANDARD SPARE PARTS 1Piece (7ZXRD0032: SPARE FUSE:58V/7.5A 2pices)

OPERATIONAL MANUARU 1Piece (This book)

TENPLATE SHEET FOR SCANNER MOUNTING SCREW HOLES 1Piece

NOTE:

This radar display is possible to use AIS, TT, LL_ position, Depth, and N-UP functions.

But those all function needs the signal input from GPS, AIS. GYRO. LOG ECHO SOUNDERS.

ALL external signals are connect using NMEA connecting cable.

This cable is option, not include standard supply items.

Option units.(Not included standard supplied items)

Please order to JRC agent or factory if necessary.

☆ **SCANNER to DISPLAY Cable : 5m,15m、 20m each one (necessary length)**

☆ **NMEA Signal connection cable: length 1m**

☆ **RGB external monitor connection unit (NQA-2447) (Not include RGB monitor)**



☆ **Rectify unit (NBD-865) : AC100/220V to DC24V**

BEFORE OPERATION





■ PICTORIAL INDICATION

Various pictorial indications are included in this manual and are shown on these equipment so that you can operate them safely and correctly and prevent any danger to you and/or to other persons and any damage to your property during operation. Such indications and their meanings are as follows.

Understand them before you read this manual.

 DANGER	This indication is shown where incorrect equipment operation due to negligence may cause death or serious injuries.
 WARNING	This indication is shown where any person is supposed to be in danger of being killed or seriously injured if this indication is neglected and these equipments are not operated correctly.
 CAUTION	This indication is shown where any person is supposed to be injured or any property damage is supposed to occur if this indication is neglected and these equipments are not operated correctly.

■ EXAMPLES OF PICTORIAL INDICATION

	The Δ mark represents CAUTION (including DANGER and WARNING). Detailed contents of CAUTION ("Electric Shock" in the example on the left.) is shown in the mark.
	The \circledR mark represents prohibition. Detailed contents of the prohibited action ("Disassembling Prohibited" in the example on the left.) is shown in the mark.
	
	The \bullet mark represents instruction. Detailed contents of the instruction ("Disconnect the power plug" in the example on the left.) is shown in the mark.
	

■ WARNING LABEL

Warning label is patched on the equipment visible surface.

Do not try to remove, break or modify the label.



■RUSSIA CTP MARK

According to the requirements of clause 20 of Technical Regulations about safety of Maritime transport objects, approved by Resolution of the Russian Federation Government #620 dated August 12, 2010 and requirements Technical Regulation of the Russian Federation Government #623 dated August 12, 2010 navigation & radiotelephone equipment should be marked by company – manufacturer with market-circulation mark the way it is determined by Legislation of the Russia federation on technical regulation.



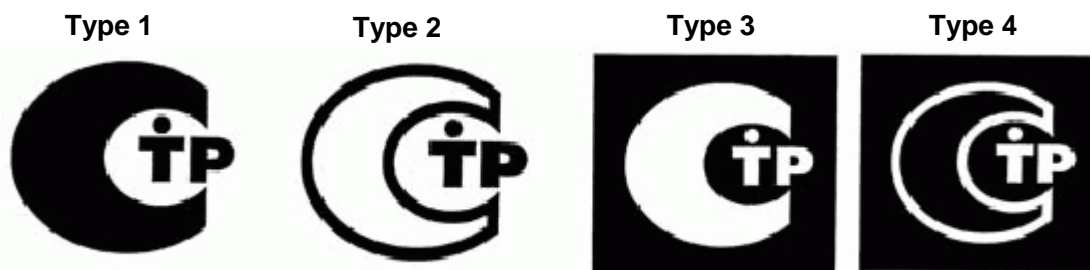

According to the article 27 PZ No184 –FZ of Federal Law about Technical Regulation dated December 12, 2002 and Resolution of the Russian Federation Government dated 19.11.03 No0696 navigation equipment has an appropriate marking. The marking can be performed by one of four variants, depending on surface colour of equipment.







The images should be grey scale and should contrast against the surface colour (ref. to the Resolution of the Russian Federation Government No696 <<About market circulation mark>> dated November 19, 2003).







The marking of Radio and navigation equipment should be done by the manufacturer (supplier) according to the clause 2 of the article 27 of the Federal Law No.184 –FZ << About technical Regulation>> and should be applied right to device surface.

PRECAUTIONS

 DANGER	
	<p>Never carry out internal inspection or repair work of the equipment by users.</p> <p>Inspection or repair work by unauthorized personnel may result in fire hazard or electric shock.</p> <p>For inspection and repair work of equipment components, consult with our branch office, branch shop, sales office, or our distributor in your district.</p>
	<p>When conducting maintenance, make sure to turn the main power off. Failure to comply may result in electrocution.</p>
	<p>Turn off the main power before cleaning the equipment. Especially when a rectifier is used, make sure to turn it off since voltage is still output from the rectifier even after the radar is turned off.</p> <p>Failure to comply may result in equipment failure, electric shock or serious injury.</p>
	<p>When conducting maintenance work on the antenna, make sure to turn its main power off.</p> <p>Failure to comply may result in electrocution or injuries.</p>

WARNING

	<p>Never directly touch the internal components of the antenna, receiver/transceiver, or indicator.</p> <p>Direct contact with these high-voltage components may cause electrocution. For maintenance, inspection, or adjustment of equipment components, consult with our branch office, branch shop, sales office, or our distributor in your district.</p>
	<p>Microwave radiation level:</p> <p>Keep away from a scanner when it is transmitting.</p> <p>The high level of microwave is radiated from the front face of the scanner specified below. The microwave exposure at close range could result in injuries (especially of the eyes).</p>
	<p>Make sure to install the antenna at a place higher than human height.</p> <p>Direct exposure to electromagnetic waves at close range will have adverse effects on the human body.</p>
	<p>Direct exposure to electromagnetic waves at close range will have adverse effects on the human body. When it is necessary to get close to the antenna for maintenance or inspection purposes, make sure to turn the indicator power switch to "OFF" or "STBY."</p> <p>Direct exposure to electromagnetic waves at close range will have adverse effects on the human body.</p>
	<p>When conducting maintenance work, make sure to turn off the power and unplug the power connector J1 of the display unit so that the power supply to the equipment is completely cut off.</p> <p>Some equipment components can carry electrical current even after the power switch is turned off, and conducting maintenance work without unplugging the power connector may result in electrocution, equipment failure, or accidents.</p>

 CAUTION	
	<p>A malfunction may occur if the power in the ship is instantaneously interrupted during operation of the radar. In this case, the power should be turned on again.</p>
	<p>Always use the automatic tuning mode. Use the manual tuning mode only when the automatic tuning mode does not provide the best tuning state due to deterioration of magnetron for example.</p>
	<p>If sensitivity is set too high, unnecessary signals such as noises in the receiver and false echoes increase to lower target visibility. At the same time, if sensitivity is set too low, detection of targets such as ships and dangerous objects may be hindered. Therefore, sensitivity must always be set to an optimal level.</p>
	<p>When using the sea clutter suppression function, never set the suppression level too high canceling out all image noises from the sea surface at close range. Detection of not only echoes from waves but also targets such as other ships or dangerous objects will become inhibited. When using the sea clutter suppression function, make sure to choose the most appropriate image noise suppression level.</p>
	<p>Use the radar only as a navigation aid. The final navigation decision must always be made by the operator him/herself. Making the final navigation decision based only on the radar display may cause accidents such as collisions or running aground.</p>
	<p>Use the target tracking function (TT) only as a navigation aid. The final navigation decision must always be made by the operator him/herself. Making the final navigation decision based only on the target tracking function (TT) information may cause accidents. The target tracking function (TT) information such as vector, target numerical data, and alarms may contain some errors. Also, targets that are not detected by the radar cannot be acquired or tracked. Making the final navigation decision based only on the radar display may cause accidents such as collisions or running aground.</p>



CAUTION

	<p>Target Tracking Function Test is provided to test if the target tracking function is operating normally. Thus, do not use the function except when you test the target tracking function.</p> <p>Note especially that, if this function is used during actual navigation, simulated targets are displayed and may become confused with other actual targets. Therefore, never use this function during actual navigation.</p>
	<p>When a large value is set as an association condition, a tracked target near an AIS target is identified as the AIS target and may thus disappear from the display.</p> <p>For example, when a pilot vessel equipped with the AIS function (a small target which is not a tracked target) goes near a cargo vessel which is a tracked target without the AIS function, the tracked target symbol for the cargo vessel may disappear.</p>
	<p>Since these alarms may include some errors depending on the target tracking conditions, the navigation officer himself should make the final decision for ship operations such as collision avoidance.</p> <p>Making the final navigation decision based only on the alarm may cause accidents such as collisions.</p>
	<p>When setting an automatic acquisition zone, make sure to properly adjust gain, sea-surface reflection suppression level, and rain/snow reflection suppression level so that the optimal target images are always on the radar screen. The automatic acquisition zone alarm will not be activated for targets undetected by the radar, and it may result in accidents such as collisions.</p>
	<p>Any adjustments must be made by specialized service personnel. Incorrect settings may result in unstable operation.</p>
	<p>Do not make any adjustments during navigation. Failure to comply may result in adverse effects on the radar function which may lead to accidents or equipment failure.</p>
	<p>Any adjustments must be made by specialized service personnel. Failure to comply may result in accidents or equipment failure.</p>
	<p>Make sure to shut off the main power before replacing parts. Failure to comply may result in electrocution or equipment failure.</p>



CAUTION



When replacing magnetrons, make sure to shut off the main power and let the equipment stand for more than 5 minutes to discharge the high-voltage circuit.

Failure to comply may result in electrocution.



Make sure to take off your watch when your hand must get close to the magnetron.

Failure to comply may result in damage to the watch since the magnetron is a strong magnet.



When cleaning the display screen, do not wipe it too strongly with a dry cloth. Also, do not use gasoline or thinner to clean the screen.

Failure to comply will result in damage to the screen surface.

WARNING LABEL MOUNTING POINT

NKE-1066 SCANNER UNIT

View from cable inlet side.

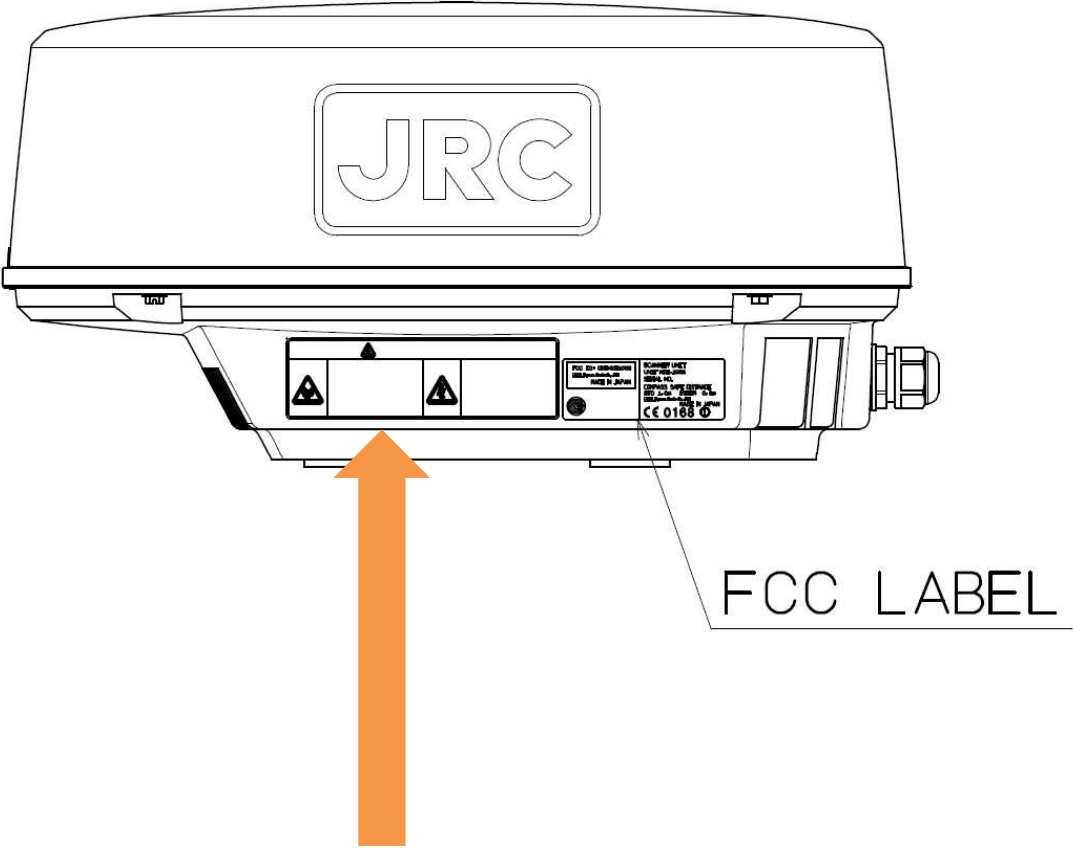

NKE-2044 SCANNER UNIT

View from cable inlet side.

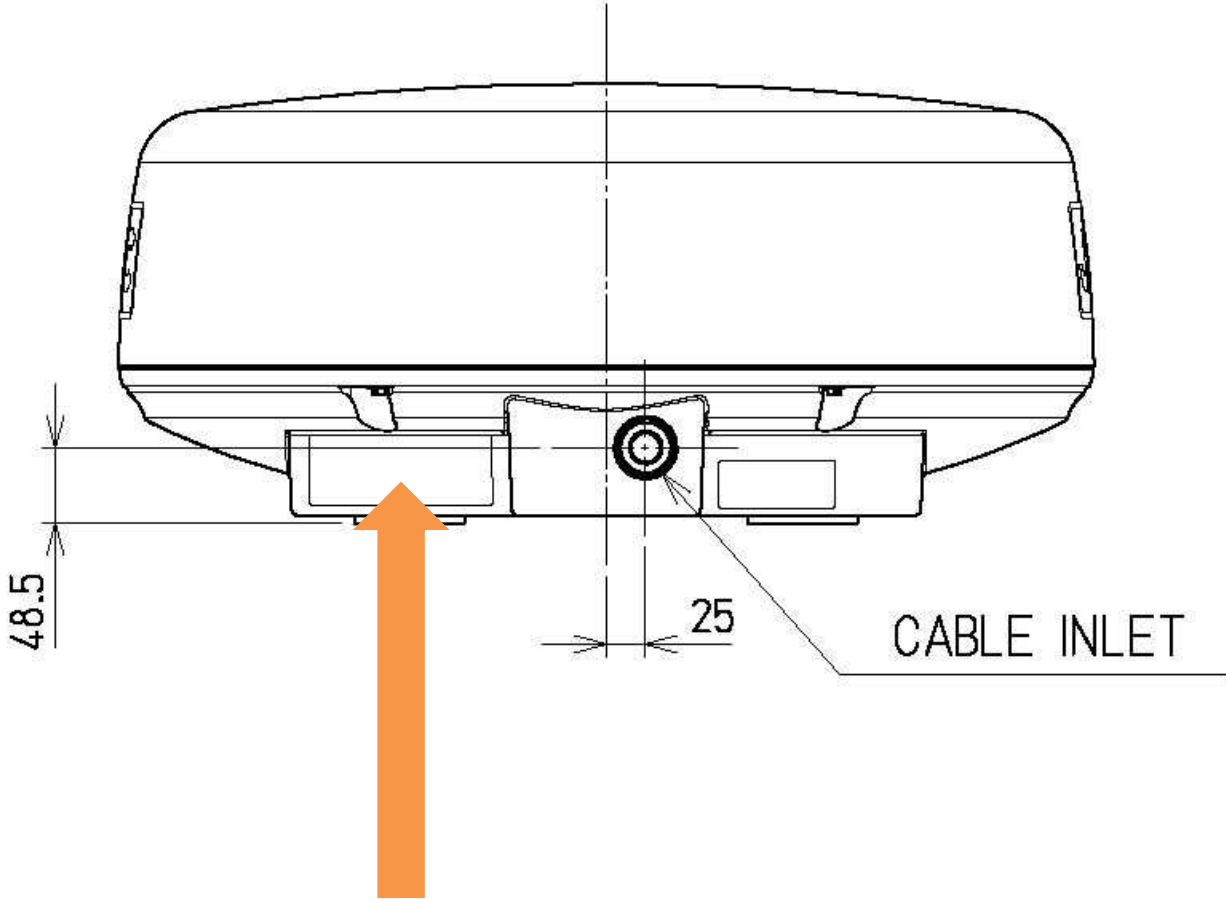

⚠ 警告 WARNING			
	送信中は近づくな 電磁波傷害の恐れあり RADIATION HAZARD DO NOT APPROACH		このカバーをはずすな 感電の恐れあり HIGH VOLTAGE DO NOT REMOVE THE COVER

EQUIPMENT APPEARANCE

JMA-1030 is a series name.

Individual TYPE name are change by combination of units.

TYPE	JMA-1032	NCD-2256	+	NKE-1066
TYPE	JMA-1034	NCD-2256	+	NKE-2044

JMA-1030 Series system diagram

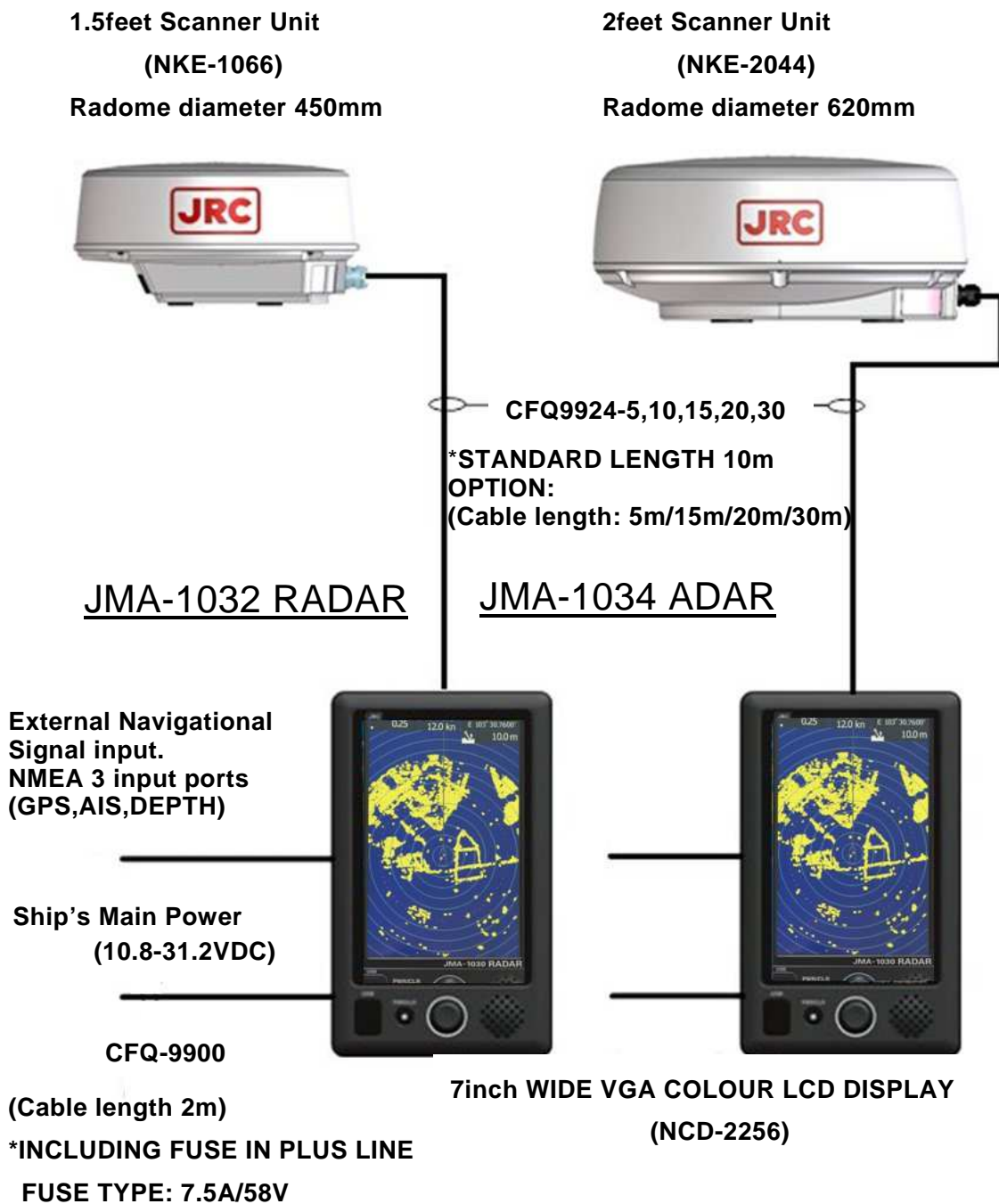

DISPLAY APPEARANCE

DISPLAY TYPE NAME NCD-2256

TABLE TOP MOUNTING





SCANNER APPEARANCE

1.5-FT SCANNER NKE-1066

2FT SCANNER NKE-2044

FCC ID: CKENKE1066  <i>Japan Radio Co., Ltd.</i> MADE IN JAPAN	SCANNER UNIT UNIT NKE-1066 SERIAL NO. COMPASS SAFE DISTANCE STD 1.0m STEER 0.6m  <i>Japan Radio Co., Ltd.</i> MADE IN JAPAN CE 0168 ⓘ
---	--

FCC ID: CKENKE2044  <i>Japan Radio Co., Ltd.</i> MADE IN JAPAN	SCANNER UNIT UNIT NKE-2044 SERIAL NO. COMPASS SAFE DISTANCE STD 1.2m STEER 0.7m  <i>Japan Radio Co., Ltd.</i> MADE IN JAPAN CE 0168 ⓘ
---	--

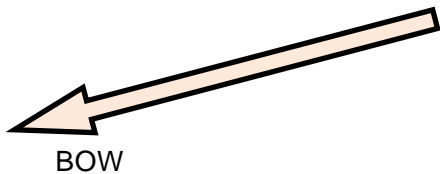

BOW

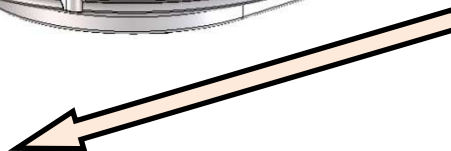

BOW

NCD-2256 + NKE-1066

NCD-2256 + NKE-2044





CONTENTS

PREFACE.....	v
CHECKING THE SUPPLIED ITEMS.....	vi
BEFORE OPERATION.....	vii
PRECAUTIONS.....	x
WARNING LABEL MOUNTING POINT.....	xv
EQUIPMENT APPEARANCE.....	xvii
CONTENTS.....	A
GLOSSARY.....	a
Chapter 1 INSTALLATION.....	1
1-1 OVERVIEW.....	1
1-2 INSTALLATION OF THE DISPLAY UNIT.....	2
1-2-1 SELECTING THE INSTALLATION POSITION.....	2
1-2-2 SELECTION OF DISPLAY MOUNTING.....	2
1-2-3 DIMENSIONAL DRAWING OF DISPLAY MOUNTING.....	3
1-2-4 EXAMPLES OF DISPLAY MOUNTING.....	5
1-2-5 POWER CABLE INSTALLATION.....	10
1-2-6 EXTERNAL NAVIGATIONAL SIGNAL CONNECTION.....	11
1-3 INSTALLATION OF THE SCANNER UNIT.....	12
1-3-1 SELECTING THE INSTALLATION POSITION.....	12
1-3-2 LOWEST SCANNER INSTALLATION HEIGHT.....	13
1-3-3 MOUNTING RACK AND MAST FOR THE SCANNER.....	13
1-3-4 SCANNER AND THE SURROUNDING STRUCTURAL OBJECTS.....	14
1-3-5 ENSURING VIEW ANGLE.....	15
1-3-6 CONFIRM MOUNTING BASE BEFORE INSTALL.....	17
1-4 CONNECTING THE INSTALLATION CABLE.....	20
1-4-1 NKE-1066 SCANNER(1.5FEET).....	21
1-4-2 NKE-2044 SCANNER (2FEET).....	25
Chapter 2 START THE BASIC OPERATION.....	29
2-1 GUIDE FOR OPERATION.....	33
2-2 POWER ON (STAND BY FOR TRANSMIT).....	33
2-3 DISPLAY SCREEN.....	34
2-3-1 SCREEN LAYOUT.....	34
2-3-2 ICON'S TABLE.....	37
2-3-3 BRIEF EXPLANATION OF ICON'S FUNCTION.....	43
2-4 TRANSMIT.....	47
2-5 LEAVE THE USEFUL ICON ON SCREEN.....	49
2-6 FUNCTION CALL BY SCREEN TAP.....	51
Chapter 3 ADJUST THE RADAR ECHO.....	53
3-1 CHANGE RANGE.....	53

3-2 ADJUSTS GAIN (RADAR SENSITIVITY)	55
3-3 ADJUST SEA (CLUTTER CONTROL)	56
3-4 ADJUST RAIN AND SNOW CLUTTER CONTROL	57
3-5 ADJUST BRILLIANCE OF SCREEN	58
Chapter 4 MEASURE THE SURROUND SHIPS	60
4-1 MEASURE DIRECTION AND RANGE USING VRM/EBL	60
4-1-1 ICON DISPLAY	60
4-1-2 OPERATION OF VRM, EBL ICON	60
4-1-3 EXAMPLE OF VRM FUNCTION	61
4-1-4 EXAMPLE OF EBL FUNCTION	61
Chapter 5 USEFUL FUNCTIONS	63
5-1 MOB (MAN OVER THE BOAT)	63
5-2 OFF-CENTER FUNCTION	63
5-3 CURSOR FUNCTION	64
5-4 SETUP THE GUARD ZONE	65
5-5 TRAIL (DISPLAY THE WAKE BEHIND THE SHIP)	66
5-5-1 Selection of trail length	66
5-5-2 Select Radar Trail Mode	68
5-6 AIS (AUTOMATIC SHIP IDENTIFICATION SYSTEM)	70
5-7 TT (TARGET TRACKING)	72
Chapter 6 OPTIONAL FUNCTIONS	73
6-1 EXTERNAL MONITOR DISPLAY OUTPUT	73
6-2 NMEA CABLE (OPTIONAL PURCHASE)	74
6-3 RECTIFIER UNIT	75
Chapter 7 INITIAL SETTING	76
7-1 INITIAL SETTING MENU	76
7-1-1 RECOMMEND SETTING BEFORE INITIAL SETTING	76
7-1-2 NECESSARY SETTING BEFORE USE	76
7-1-3 ALREADY SETTED-UP IN FACTORY	76
7-2 LANGUAGE SELECTION	79
7-3 TUNING ADJUSTMENT	80
7-4 BEARING ADJUSTMENT	81
7-5 RANGE ADJUSTMENT	83
7-6 ANTENNA HEIGHT SET UP	85
7-7 ALREADY SETTED-UP ADJUSTMENT IN FACTORY	86
7-8 COMMUNICATION PORT SETUP	87
7-8-1 BAUD RATE	88
7-8-2 RX PORT	88
7-8-3 TX PORT	90
7-8-4 TX DATA FORMAT	92
7-8-5 TARGET INFORMATION TX	93
7-9 EXTERNAL INPUT SIGNAL SELECTION	94

7-9-1 HEADING SIGNAL DEVICE SELECT..... 94

7-9-2 MANUAL HEADING INPUT..... 95

7-9-3 SPEED INPUT SELECTION 95

7-9-4 MANUAL SPEED INPUT 96

7-9-5 MAGNETIC COMPASS SETUP 96

Chapter 8 DETAIL PERFORMANCE SETTING.....97

8-1 RADAR ECHO SETUP..... 97

8-1-1 MAIN BANG SUPPRESSION..... 100

8-1-2 TARGET EXPANSION..... 101

8-1-3 GAIN LEVEL..... 101

8-1-4 SEA CLUTTER LEVEL 102

8-1-5 RAIN AND SNOW CLUTTER LEVEL 103

8-1-6 RADAR Alarm LEVEL 104

8-2 TT(TARGET TRACKING) FUNCTION 105

8-3 SCANNER FUNCTION..... 107

8-3-1 PULSE REPETITION FREQUENCY FINE TUNING (PRF ADJUST)..... 107

8-3-2 STAGGER TRIGGER..... 108

8-3-3 SCANNER ROTATIONAL SPEED..... 109

8-3-4 ECONOMY MAGNETRON SETUP (PRF , PULSE LENGTH)..... 110

8-3-5 TIMED TX..... 110

8-3-6 TUNE PEAK LEVEL..... 111

8-3-7 TUNE INDICATOR LEVEL 111

8-4 CONTROL 112

8-4-1 BEARING REFERENCE..... 112

8-4-2 BUZZER..... 112

8-5 MAINTENANCE SETTING 114

8-5-1 SYSTEM TIME CLEAR 114

8-5-2 SCANNER TIME CLEAR 114

8-6 SYSTEM SETTING 116

8-6-1 MASTER/SLAVE/DEMO..... 116

8-6-2 Own Ship Outline 116

8-6-3 UNIT 117

8-6-4 MOVE OWN SHIP 119

8-6-5 USE RANGE SELECT 120

8-7 DISPLAY SCREEN 122

8-7-1 OWN VECTOR DISPLAY 122

8-7-2 ST-BY DISP SELECT..... 122

8-7-3 OPERATION NUMERICAL DISPLAY..... 123

8-7-4DISPLAY COLOR 123

8-7-5WAYPOINT DISPLAY..... 130

8-7-6AIS FILTER..... 130

8-8 ERROR ALARM MASK..... 131

8-8-1 SCANNER.....	131
8-8-2 DISPLAY UNIT	133
8-8-3 CONNECTION DEVICE	135
8-8-4 RX DATA	136
Chapter 9 MAINTENANCE AND CHECK.....	138
9-1 ROUTINE MAINTENANCE	138
9-2 MAINTENANCE OF EACH UNIT	139
9-2-1 SCANNER NKE-1066.....	139
9-2-2 SCANNER NKE-2044.....	140
9-2-3 DISPLAY NCD-2256	141
9-3 PERFORMANCE CHECK.....	142
9-3-1 TEST MENU.....	143
9-3-2 SYSTEM INFORMATION.....	143
9-3-3 SYSTEM TIME.....	143
9-3-4 SCANNER INFORMATION	144
9-3-5 HARDWARE INFORMATION.....	144
9-3-6 ERROR LOG	144
9-3-7 LINE MONITOR.....	144
9-3-8 SELF TEST	145
9-4 REPLACEMENT OF MAJOR PARTS	147
9-4-1 PARTS REQUIRED FOR PERIODIC REPLACEMENT.....	148
9-5 FAULT FINDING.....	149
9-5-1 ALARMS AND OTHER DISPLAY LISTS.....	149
9-5-2 FUSE.....	149
9-6 TROUBLE SHOOTING	149
9-6-1 INCLUDED ACCESSORIES.....	149
9-6-2 SPECIAL PARTS	149
9-6-3 CIRCUIT BLOCK TO BE REPAIRED	150
Chapter 10 AFTER-SALE SERVICE	152
10-1 KEEPING PERIOD OF MAINTENANCE PARTS	152
10-2 WHEN YOU REQUEST FOR REPAIR	152
10-3 RECOMMENDED MAINTENANCE	152
10-4 RADAR FAILURE CHECK LIST	153
Chapter 11 DISPOSAL	154
11-1 DISPOSAL OF THE UNIT	154
11-2 DISPOSAL OF USED MAGNETRON.....	155
11-3 CHINA ROHS	155
Chapter 12 SPECIFICATIONS	158
12-1 SCANNER DIMENSION	159
12-1-1 NKE-1066.....	159
12-1-2 NKE-2044.....	160
12-2 DISPLAY DIMENSION	161

12-2-1 NCD-2256..... 161

12-3 EQUIPMENT OUTLINE 163

12-3-1 CONFIGURATION 163

12-3-2 FEATURE 163

12-3-3 RADAR MODEL 163

12-3-4 SYSTEM DIAGRAM 164

12-4 GENERAL SPECIFICATIONS 165

12-5 SCANNER 166

12-5-1 SCANNER (NKE-1066) SPECIFICATION 166

12-5-2 SCANNER (NKE-2044) SPECIFICATION 167

12-6 DISPLAY 168

12-6-1 INTEGRATED DISPLAY UNIT (NCD-2256) 168

12-6-2 OPERATIONAL PANEL 170

12-6-3 AIS FUNCTION (STANDARD BUILT IN)..... 170

12-6-4 TT FUNCTION (STANDARD BUILT IN)..... 170

12-7 INPUT/ OUTPUT SIGNAL 171

12-7-1 INPUT ENABLE SIGNAL..... 171

12-7-2 OUTPUT POSSIBLE SIGNAL (THREE-LINE GPS/HDG/TTM)..... 172

12-7-3 STANDARD CONFIGURATION..... 172

12-7-4 OPTION CABLE..... 172

Chapter 13 APPENDIX 1

NKE-1066(1.5FT) SCANNER INTRCONNECTION DIAGRAM..... 1

NKE-2044(2FT) SCANNER INTRCONNECTION DIAGRAM..... 2

NCD-2256 DISPLAY UNIT INTER CONNECTION DIAGRAM..... 3

JMA-1030 PRIMARY POWER SUPPLY DIAGRAM..... 4

JMA-1030 INTER CONNECTION DIAGRAM..... 5

OPERATION SHEET..... 7

MENU FUNCTION LIST 8

GLOSSARY

This section describes the main terms used for this equipment and general related maritime terms.

A

AZ	Acquisition/Activation zone A zone set up by the operator in which the system should automatically acquire radar targets and activate reported AIS targets when entering the zone.
Activated target	A target representing the automatic or manual activation of a sleeping target for the display of additional information.
AIS	Automatic Identification System A system which enables ships and shore stations to obtain identifying and navigation information about other ships at sea, using an automated transponder.
Anti-clutter rain	Rain/snow clutter suppression.
Anti-clutter sea	Sea clutter suppression.
AZI	Azimuth stabilization mode

B

BCR/BCT	Bow Crossing Range and Bow Crossing Time
---------	--

C

C up	Course up Own ship's course is pointed to the top center of the radar display.
CCRP	The Consistent Common Reference Point A location on own ship, to which all horizontal measurements such as target range, bearing, relative course, relative speed, CPA or TCPA are referenced, typically the conning position of the bridge.
Clutter	Unwanted reflections on a radar screen, from sea surface, rain or snow.
COG	Course Over Ground The direction of the ship's movement relative to the earth, measured on board the ship, expressed in angular units from true north
CORREL	Correlation
CPA/TCPA	The distance to the Closest Point of Approach and Time to the Closest Point of Approach. Limits are set by the operator and are related to own ship.
CTW	Course Through Water The direction of the ship's movement through the water

D

DRIFT	The current velocity for manual correction or the current speed on the horizontal axis of the 2-axis log is displayed.
-------	--

E

EBL Electronic Bearing Line
An electronic bearing line originated from own ship's position.

ENH Enhance

ETA Estimated Time of Arrival

G

Ground stabilization A display mode in which speed and course information are referred to the ground, using ground track input data.

H

HDG Heading
The horizontal direction that the bow of a ship is pointing at any instant, expressed in angular units from a reference direction.

HL Heading line
A graphic line on a radar presentation drawn from the consistent common reference point to the bearing scale to indicate the heading of the ship

H up Head up
Own ship's heading line is always pointed to the top center of the radar display.

I

IR Radar Interference Rejecter

L

Lost AIS target A target symbol representing the last valid position of an AIS target before the reception of its data was lost, or its last dead-reckoned position.

Lost tracked target One for which target information is no longer available due to poor, lost or obscured signals.

LP Long Pulse

M

MMSI Maritime Mobile Service Identity

MOB Man Over Board

MP Medium Pulse

N

NM 1NM=1852m

NSK North Stabilization Kit

N up North up
The north is always pointed to the top center of the radar display.

O

Own track Display function of own ship's track

P

PI	Parallel Index line
Past positions	Equally time-spaced past position marks of a tracked or AIS target and own ship.
POSN	Position
PRF	Pulse Repetition Frequency The number of radar pulses transmitted each second.
PROC	Process Radar signal processing function

R

Radar beacon	A navigation aid which responds to the radar transmission by generating a radar signal to identify its position and identity
Radar cross-section	Radar cross-section of a target determines the power density returned to the radar for a particular power density incident on the target
Range Rings	A set of concentric circles labeled by distance from CCRP.
Reference target	A symbol indicating that the associated tracked stationary target is used as a speed reference for the ground stabilization
Relative course	The direction of motion of a target relative to own ship motion
Relative speed	The speed of a target relative to own ship's speed data
Relative vector	A predicted movement of a target relative to own ship's motion
RM	Relative Motion A display on which the position of own ship remains fixed, and all targets move relative to own ship.
RM(R)	Relative Motion. Relative Trails.
RM(T)	Relative Motion. True Trails.
ROT	Rate Of Turn Change of heading per time unit.
Route	A set of waypoints.
RR	Range Rings

S

SART	Search And Rescue Transponder Radar transponder capable of operating in the 9GHz band
Sea stabilization	A display mode in which speed and course information are referred to the sea.
Sea state	Status of the sea condition due to the weather environment, expressed as a sea state 0 for flat conditions with minimal wind, to sea state 8 for very rough sea conditions.
SET	The current direction for manual correction or the current speed on the horizontal axis of the 2-axis log is displayed.
Sleeping AIS target	A target indicating the presence and orientation of a vessel equipped with AIS in a certain location.
SOG	Speed Over the Ground The speed of the ship relative to the earth, measured on board of the ship.
SP	Short Pulse
STAB	Stabilization
STW	Speed Through Water The speed of the ship relative to the water surface.

T

TCPA	Time to Closest Point of Approach to own ship
Test target	Radar target of known characteristics used for test requirement
TM	True Motion A display across which own ship moves with its own true motion.
Trails	Display Radar Trails (Other Ships' Trails)
True course	The direction of motion relative to ground or to sea, of a target expressed as an angular displacement from north
True speed	The speed of a target relative to ground, or to sea
True vector	A vector representing the predicted true motion of a target, showing course and speed with reference to the ground or sea
TT	Target Tracking. A computer process of observing the sequential changes in the position of a radar target in order to establish its motion. Such a target is a Tracked Target.
TTG	Time To Go. Time to next waypoint.
TXRX	Transceiver Unit

U

UTC Universal Time Coordinated.
The international standard of time, kept by atomic clocks around the world.

V

VRM Variable Range Marker
An adjustable range ring used to measure the distance to a target.

W

Waypoint A geographical location on a route indicating an event.

Chapter 1 INSTALLATION

1-1 OVERVIEW

The proper installation of the radar equipment is critical in ensuring its effective and reliable performance as well as facilitating maintenance and repair. Carefully install the radar equipment by following the procedures below.

- Install the scanner as high as possible while taking the scanner's weight into consideration.
- It is preferable to install the display unit in the wheel house to facilitate observations.
- Available cable lengths and types for installing the radar JMA-1030 are as shown in the table below. Request an appropriate cable from JRC beforehand.

A cable longer than the sufficient length may degrade radar performance, so give it careful consideration when planning the installation.

10-m cable is the standard configuration.

Installation cable

TYPE CFQ9924-10 **Length 10m (8core) STANDARD SUPPLY**



CFQ9924-5	5m (8core)	*Option
CFQ9924-15	15m (8 core)	*Option
CFQ9924-20	20m (8 core)	*Option
CFQ9924-30	30m (8 core)	*Option

Power Cable CFQ-9900 2m
STANDARD SUPPLY



Installation cable Length 10m

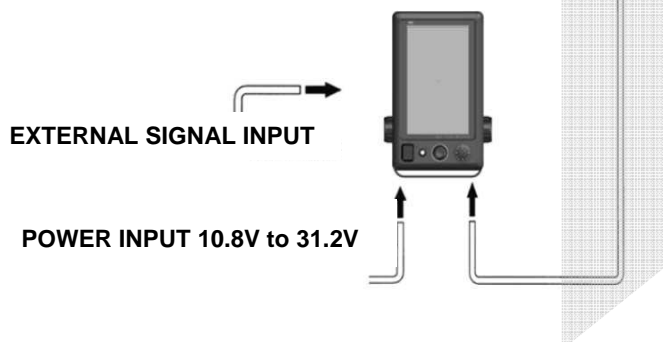

1-2 INSTALLATION OF THE DISPLAY UNIT

1-2-1 SELECTING THE INSTALLATION POSITION

Select the display unit installation position by taking into consideration the following.

- Install the display unit so that the user can easily conduct observations.
- To reduce effect on the magnetic compass, install the display unit more than 1 meter away from the compass.
- Take precautions to prevent water from splashing through the window or door of the bridge onto the display unit.
- Install the display unit by considering convenience of maintenance.
- Install the display unit so that when the user is looking ahead, the lookout view is not obscured.
- Install the unit away from direct sunlight and heat source.

1-2-2 SELECTION OF DISPLAY MOUNTING

Display is designed to various mounting way for users circumstance.

(The attachment tool is required for option except desk top installation.)

Mounting way (1) desk top installation, (2) flush mount, (3) ceiling installation.

■ DESKTOP INSTALLATION

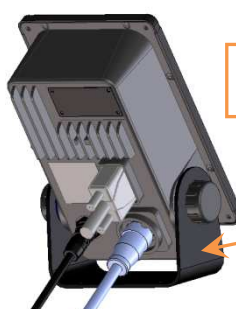

Standard mounting base.

■ FLUSH MOUNTING



Front cap

■ CEILING INSTALLATION



Option: Fixation tool



1-2-3 DIMENSIONAL DRAWING OF DISPLAY MOUNTING

REAR CASE
 COLOR : N2.5 SEMI-GLOSS
 OTHER COLOR : NOT ACCEPTABLE

FRONT PANEL
 COLOR : N2.5 SEMI-GLOSS
 OTHER COLOR : NOT ACCEPTABLE

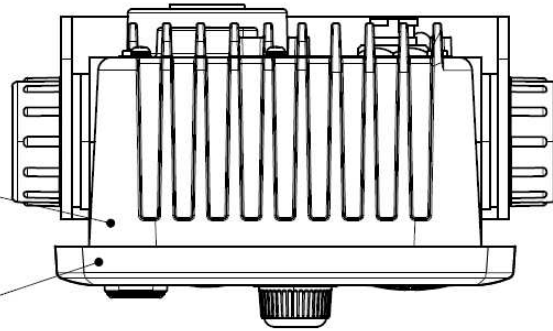

4- ϕ 4.6 FLUSH MOUNTING HOLES

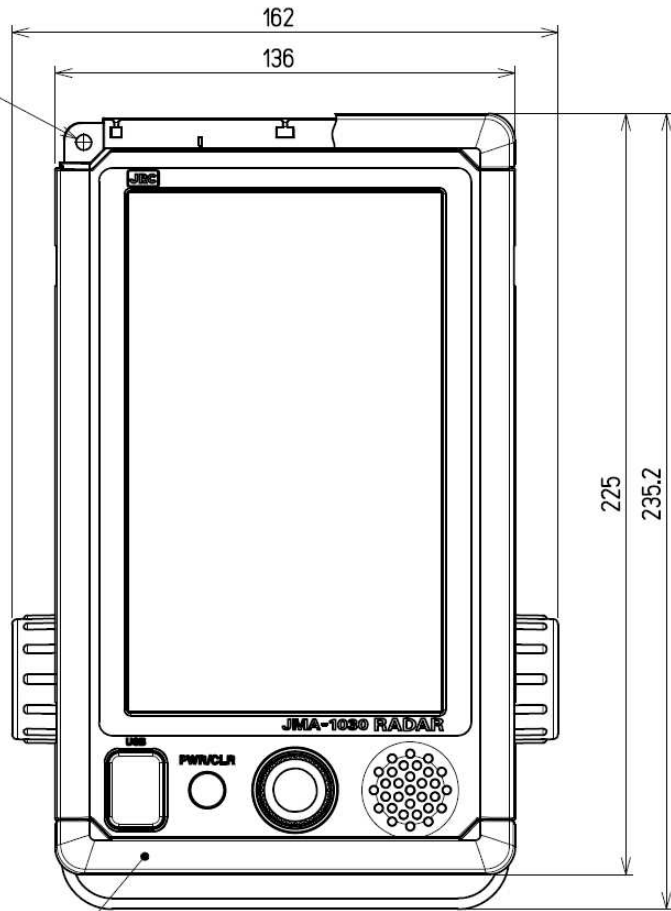
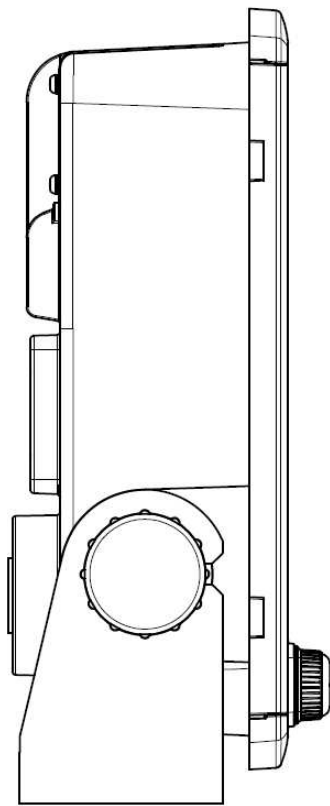

FRONT CAP

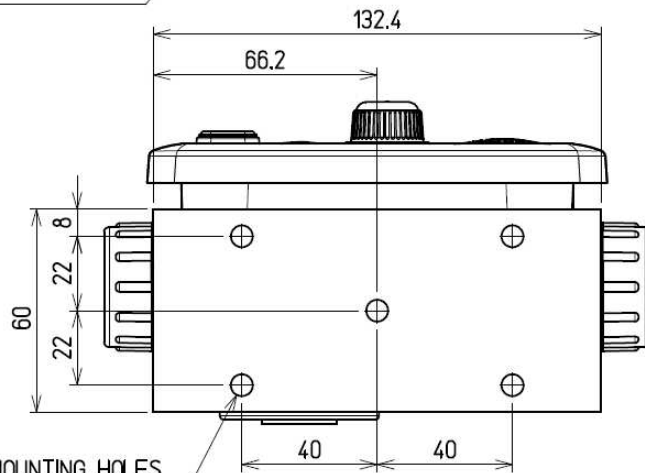

4- ϕ 6.5 MOUNTING HOLES

OUTLINE DIMENSIONS		PERMISSIBLE OUTLINE DIMENSIONAL DEVIATIONS	PERMISSIBLE MOUNTING DIMENSIONAL DEVIATIONS
OVER	TO		
3	6	±0.5	±0.5
6	30	±1	
30	120	±1.5	±1
120	400	±2.5	
400	1000	±4	±2

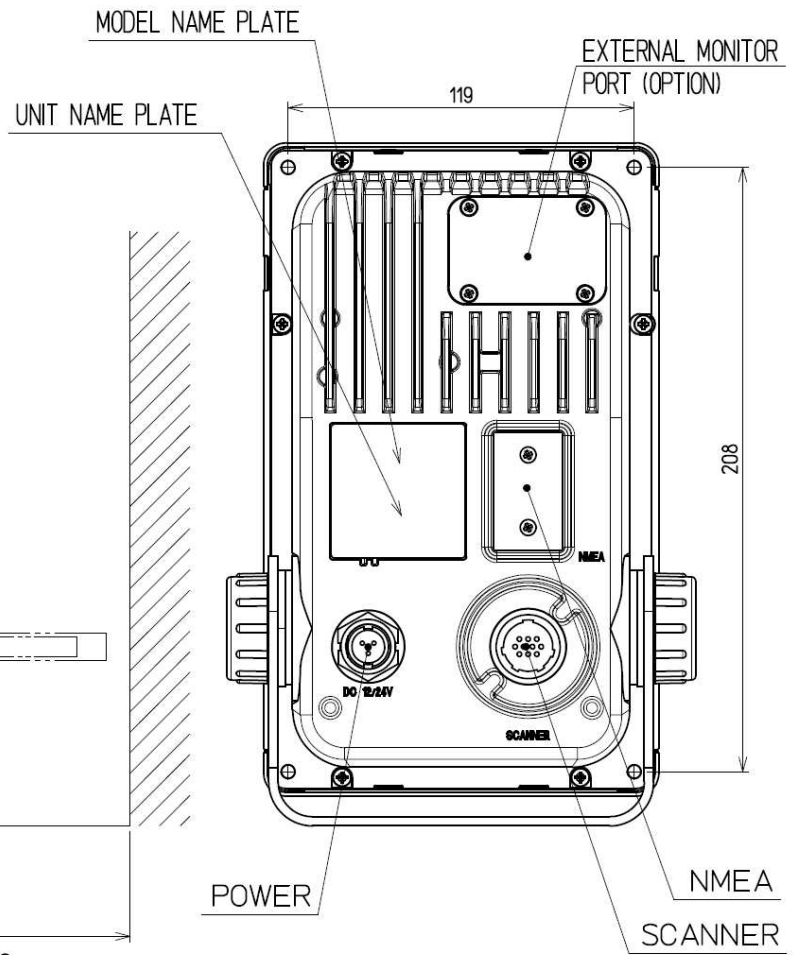
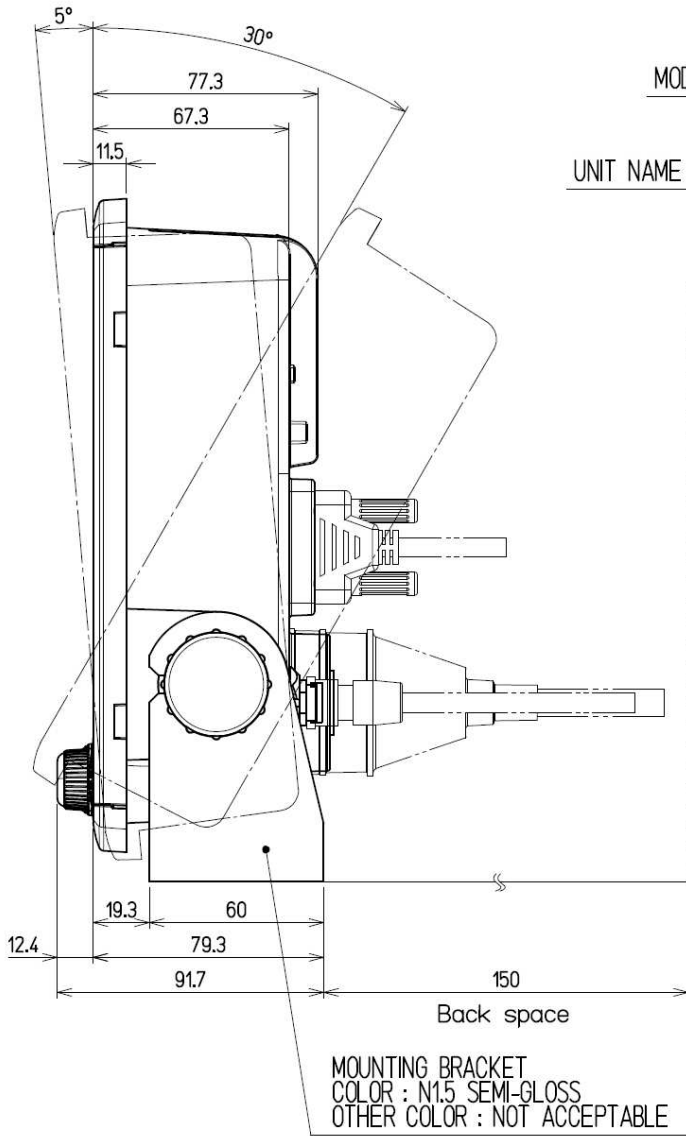

1-2-4 EXAMPLES OF DISPLAY MOUNTING

■ DESK TOP INSTALLATION



Standard mounting base.

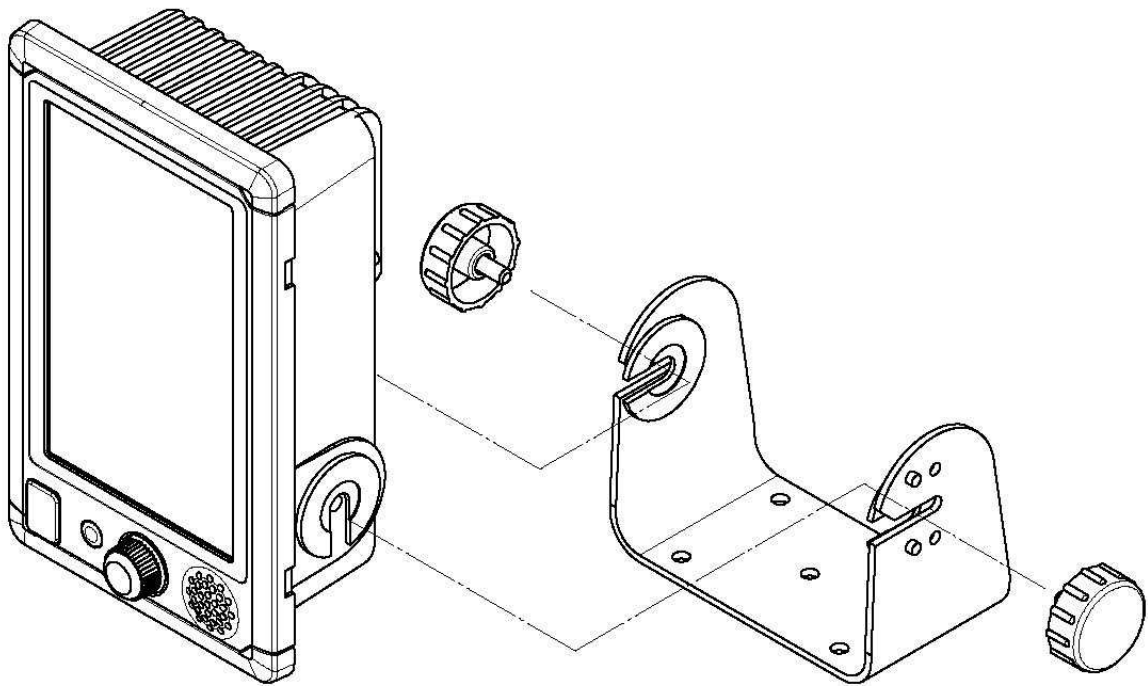

Disktop Mounting Template.

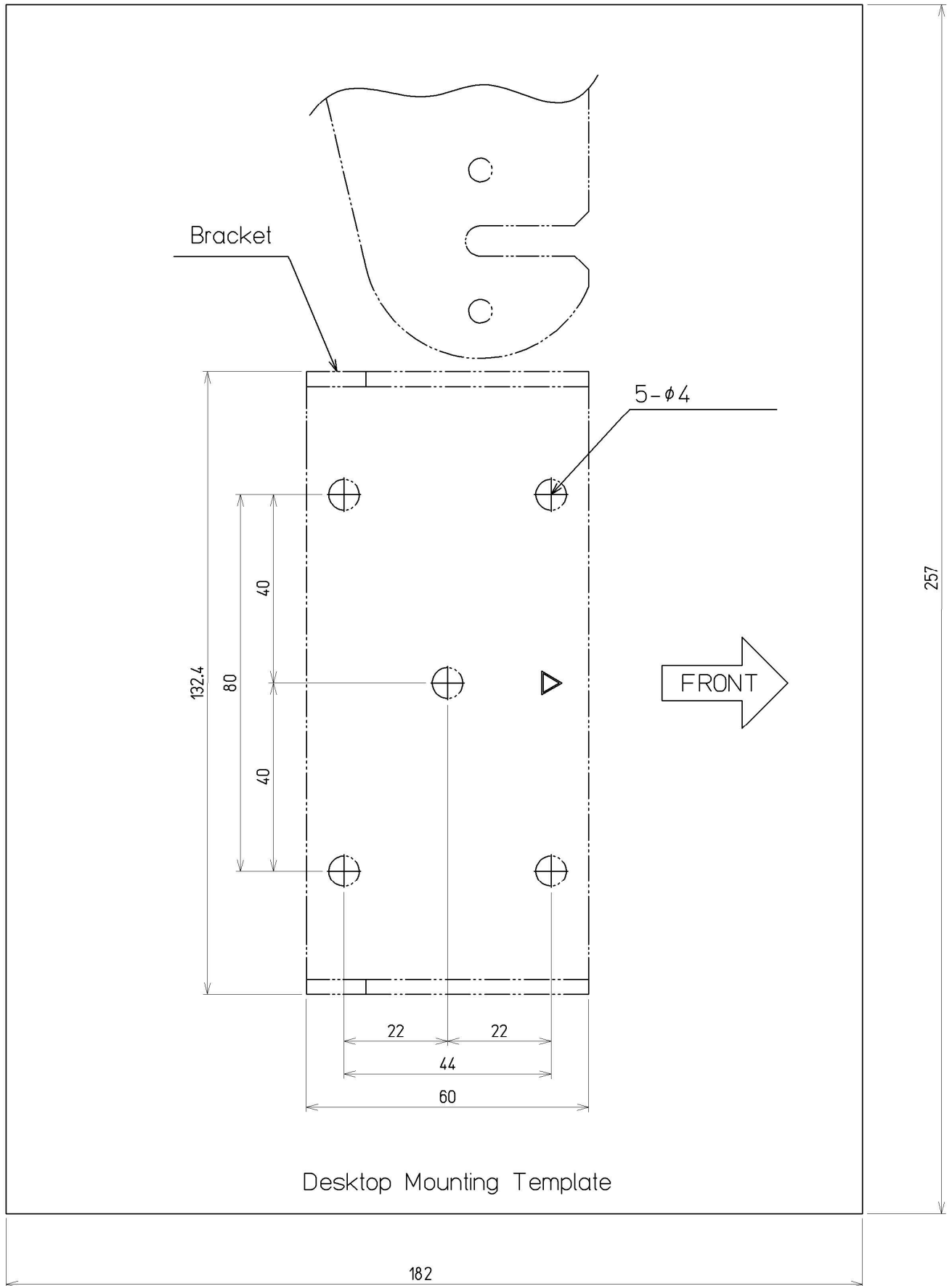

■ FLUSH MOUNT

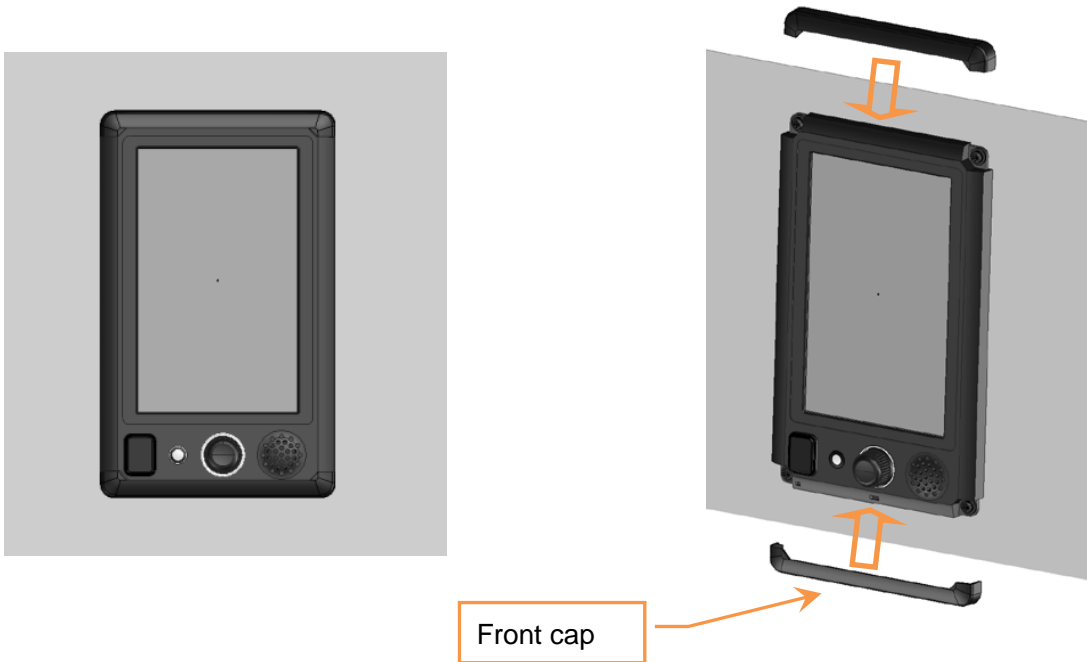

Flash mount:

Remove base, and take out cover of front panel

Fix with the front 4corner screws to the wall.

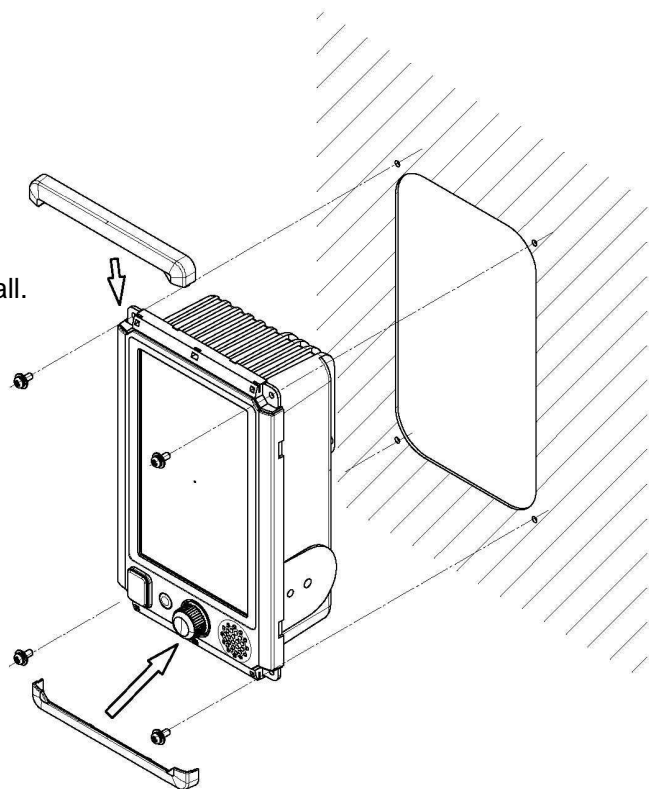

Flush Mounting Template

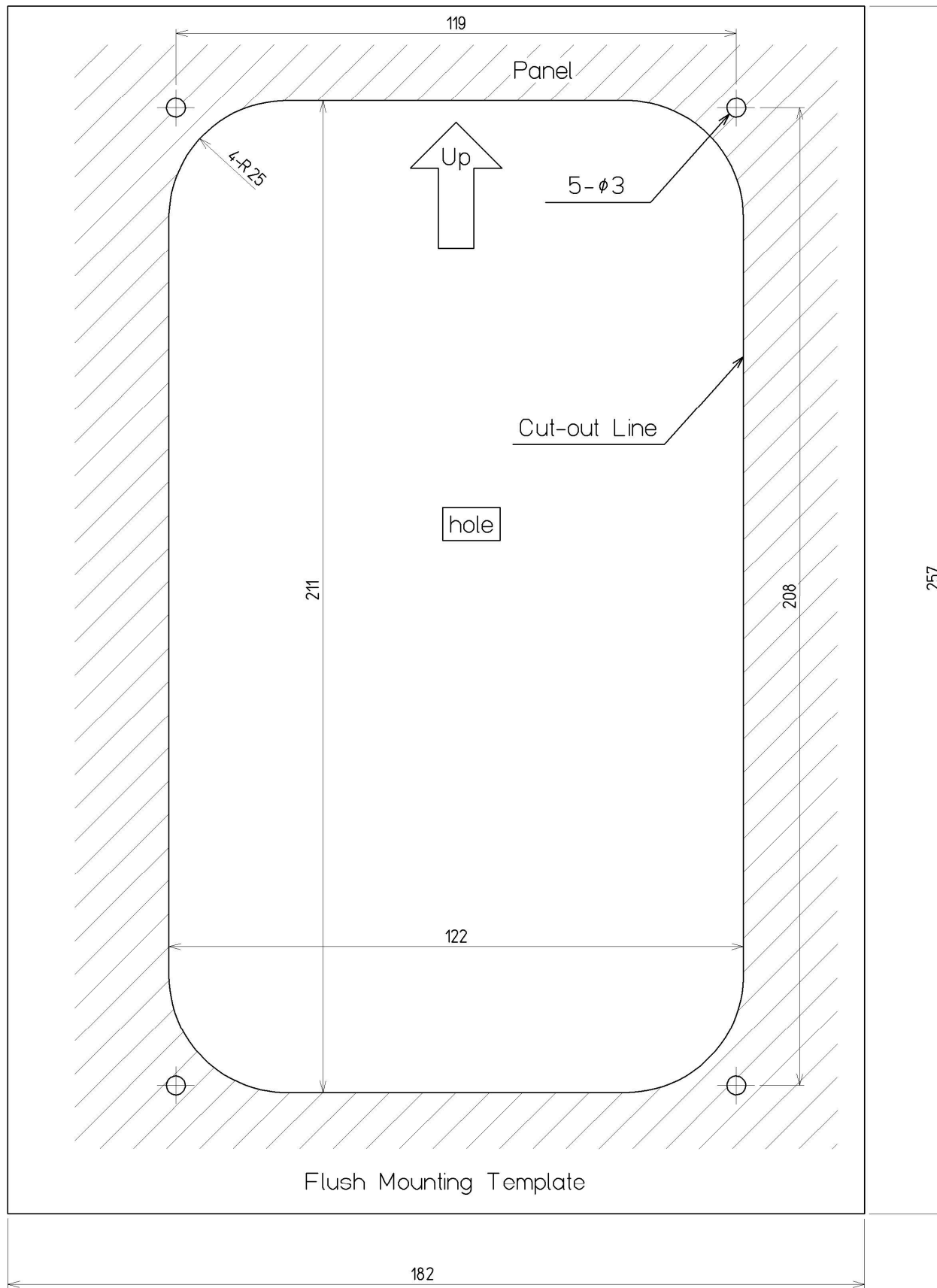

■ CEILING INSTALLATION



1-2-5 POWER CABLE INSTALLATION

This radar includes 2m power cable, which radar side was already ended with connector.

Cable assembly name: **CFQ-9900**

The cable's core color is white (+), black (-), shield mesh + green (frame ground).

Wire : AWG16

The fuse box is built into the cable (white line side).

In the case of fuse brown, please carry out exchange insertion of the same rate thing.

(Fuse: 58V/7.5A)

Red : +12/24V

Black : -0V

Shield + green: FG (frame ground)

Please connect power supply cable terminals using crimper firmly.



CAUTION



When you directly connect with the ship's power supply without using the optional rectifier, measure the voltage between the hull's earth and the positive side of ship's power supply, and the hull's earth and the negative side of this. And check voltage of 38 volts or more is not required.

If voltage of 38 volts or more is required, take the measures which do not require 38 volts or more between the above mentioned terminals.

Connection without taking the measures causes system failure or accident.

■ Connecting the cable to the display unit

Connect the CFQ-9900 connector to the Display "Power Input" firmly.

1-2-6 EXTERNAL NAVIGATIONAL SIGNAL CONNECTION

(GPS, AIS, GYRO, LOG, etc.) Connecting cable is option

Navigation system interfaces, such as GPS

Telecommunications standard NMEA0183 / 61162 to 1EC1 conformity

Communications protocol: 4800 bps, start 1bit, data 8bit, stop 1bit, and no parity

Input sentence NMEA0183: V1,5 : GGA/ GLL/ RMC

V2,0: GGA/G LL/ RMC/ZDA

V2,3: GGA/GLL/RMC/GNS/ZDA

(Talker= "G P" etc.)

Information ship position and the time; GGA/G NS/G LL/RMC

Day ZDA/RMC

Time of equipment: ZDA/GGA/GNS/GLL/RMC

Reference :

■ NMEA0183 content outline of standard input / output sentence

\$xxACK	Acknowledgement alarm
\$xxBWC	Bearing and Distance to Waypoint
\$xxCUR	Water current layer
\$xxGGA	Global Positioning System Fix Data
\$xxGLL	Geographic Position - Latitude/Longitude
\$xxGNS	GNSS fixdata
\$xxMTW	Water temperature
\$xxMWD	Wind direction and speed
\$xxMWV	Wind speed and angle
\$xxRMA	Recommended minimum specific LORAN-C data
\$xxRMB	Recommended Minimum Navigation Information
\$xxRMC	Recommended Minimum Specific GNSS Data
\$xxROT	Rate of turn
\$xxRSA	Ruddersensor angle
\$xxTHS	True heading and status
\$xxVBW	Dual ground/water speed
\$xxVDM	AIS VHF data-link message
\$xxVDO	AIS VHF Data-link Own-vessel report
\$xxVTG	Course Over Ground and Ground Speed
\$xxZDA	Time and date

1-3 INSTALLATION OF THE SCANNER UNIT

1-3-1 SELECTING THE INSTALLATION POSITION

■ PHYSICAL SELECTION CRITERIA

- Install the scanner at the center of the mast on the keel line.
- If the scanner cannot be installed at the above position for some reason, the amount of deviation must be minimized. And, reinforce the mount base and the platform and take precautions to protect the scanner from vibration and impact at the installation position.
- There needs to be no influence of the dust by smoke from a chimney.
- Please secure maintenance spaces (a platform, a safety link, a handrail, a step, etc.).

■ ELECTRICAL SELECTION CRITERIA

- The installation height of the scanner relates to the maximum detection distance.
The higher, the better. However, if it is too high, radio wave energy greatly attenuates above the scanner's vertical beam width (the point -3 dB from the peak of the main-lobe). As a result, it is difficult to detect a close-in target. Sea clutter also increases.
Determine the installation height by taking into consideration the weight, maximum length of the cable, and maintenance after installation. If the installation height of the scanner is low, it is difficult to detect a long distance target. The ship's mast, derrick, and chimney interfere with radiating beam causing the range that cannot be viewed on the radar display to increase.
Generally, the lowest scanner installation position is supposed to be on the A-B line shown in Fig. 1-3-2. In the case of the JMA-1030 type radar, 2θ equals 25° .
Specifically, the scanner position is normally elevated so that the chimney and the shrine-gate type mast do not interfere with radiating beam.

1-3-2 LOWEST SCANNER INSTALLATION HEIGHT

JMA-1030 : $\theta = 12.5^\circ$ $2\theta = 25^\circ$

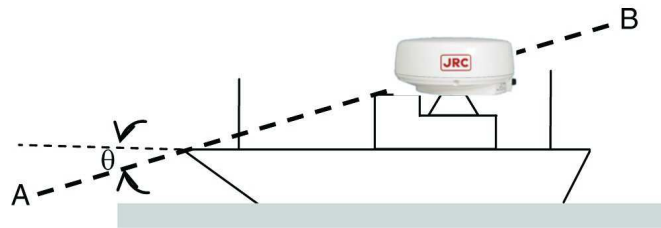

Fig. 1-3-2

- If it is considered that sufficient installation height cannot be provided when the scanner is installed directly on the roof of the wheelhouse, use a mounting rack or radar mast (Fig. 2.1-3). Normally, when the scanner installation height is less than 2 meters from the roof of the wheelhouse, provide a mounting rack assembled at an angle frame to install the scanner. When the scanner installation height is 2 m or higher from the roof of the wheelhouse, provide a cylindrical radar mast to install the scanner. Consider the convenience of the service staff who take care of installation, maintenance, adjustment, and repair of the scanner by providing adequate footholds to the mounting rack and the radar mast

1-3-3 MOUNTING RACK AND MAST FOR THE SCANNER

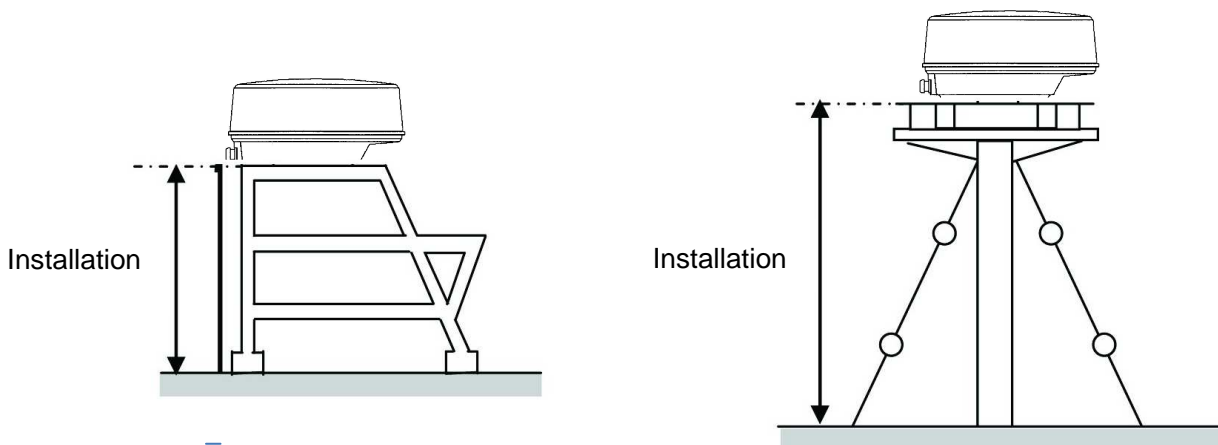

Fig. 1-3-3

- When installing the scanner, select a location where there are the fewest structural objects in the surrounding area so that false images which interfere with target detection will not be generated by signal reflection from other scanners, deck structures, and cargo. Only as a guide, note that structural objects should not exist within the range of the vertical beam width (Fig. 1-3-4).

1-3-4 SCANNER AND THE SURROUNDING STRUCTURAL OBJECTS

Vertical beam width of X-band: Approx. 20° ($\pm 10.0^{\circ}$ when the height of the radiating section is 0°).

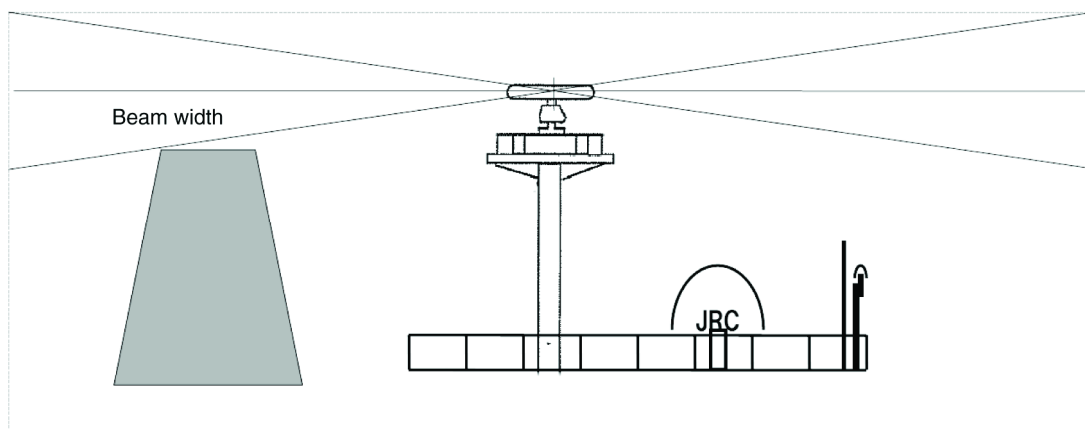

Fig. 1-3-4

When installing two scanners, provide a height difference so that those two scanners do not enter each other's vertical beam width range.

To avoid interference with other equipment and to prevent radio noise from generating, do not place the VHF antenna, GPS antenna, and INMARSAT's dome within the range of the vertical beam width. Keep a record of installation height data. The data is necessary for the initial setting of the display unit.

- Minimize the blind sector, and ensure the adequate view angle so that the blind sector does not exist in the range 22.5° from side to rear (Fig. 1-3-5). Specifically, ensure a sufficient view field in the straight front (relative bearing 000°).

1-3-5 ENSURING VIEW ANGLE

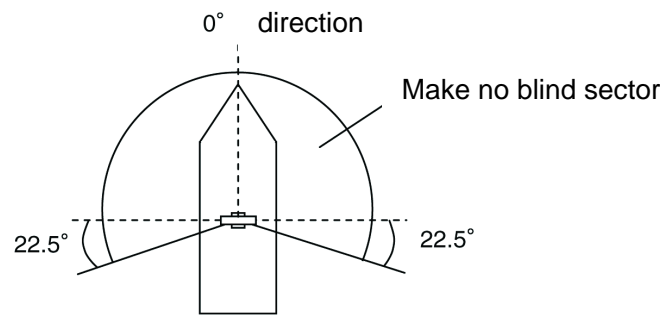

Fig. 1-3-5

- Magnetron which has strong magnetic force is included in the scanner. Install the scanner at least 3 meters away from nautical instruments including magnetic compasses and chronometers.
- * If there is a concern that structural objects existing within the vertical beam width may generate false images, equip the structural objects with a radio wave absorber. (There are two types of absorbers: broadband type having no specific resonant frequency and narrowband type which can absorb a band with a specific frequency. Use those where applicable.) Furthermore, it is effective to install a metal reflector, which reflects radio waves upwardly, between the scanner and a structural object so that the radar's radio wave will not directly come in contact with the structural object

Reference:

- Because most radio wave absorbers have poor durability, some must be replaced every year.
When installing a reflector, the area to the rear of the reflector becomes a blind sector. Therefore, minimize the size of the reflector.
 - The above procedures for selecting an scanner installation position are described based on the radar's scanner. Comprehensively select the scanner position by considering other scanners' installation procedure manual, hull's structure, strength of the selected position, and vibration.
-

■ Confirmation during test run

If the scanner vibrates a lot during test run, try to reduce or prevent vibration by reinforcing the scanner mount base or using wire stays attached to the radar mast.

■ Others

- The design of the mounting platform for the scanner should take into account the vibration requirements defined by IEC 60945.

Vibration

Frequency	2 to 13.2 Hz 13.2 Hz to 100 Hz
Amplitude	+/-1 mm +/-10 %
Acceleration	7m/s² constant

- All installations should facilitate protection of equipment, including cabling, from damage.
 - The cables should be kept as short as possible to minimize attenuation of the signal.
 - Crossing of cables should be done at right angles(90°) to minimize magnetic field coupling.
 - Install the radar cable as far as from the cables of other radio equipment in order to prevent other radio equipment from interfering with the radar operations. Especially inter-wiring cables between scanner unit and display unit of the radar should not be run parallel with the cables of other radio equipment.
 - Cable should not be exposed sharp bends.
 - Ensure that the equipment is grounded.
- Maintain a flat level surface on which to install the scanner.
- Use sufficiently thick steel material and reinforcement material for the scanner's installation surface (mount base) to reduce vibration and impact. Keep the mount base flat and smooth.
 - If there is a partial gap between the mount base and the scanner chassis's legs, work on the installation surface so that it becomes flat and smooth, or make adjustments by inserting metal shims.
If a gap exists and the scanner is tightly clamped, the chassis will distort and become damaged by vibration.
- Avoid using vibration-proof rubber and resin
- Do not insert an elastic body, such as vibration-proof rubber or resin, between the mount base and the scanner chassis' legs. If rubber or resin is inserted, the amplitude of vibration increases, resulting in the possibility of damage to the scanner.
Furthermore, if installation bolts become loose due to deterioration of rubber or resin, the scanner may be damaged or fall from its mount

1-3-6 CONFIRM MOUNTING BASE BEFORE INSTALL

NKE-1066 1.5FT SCANNER

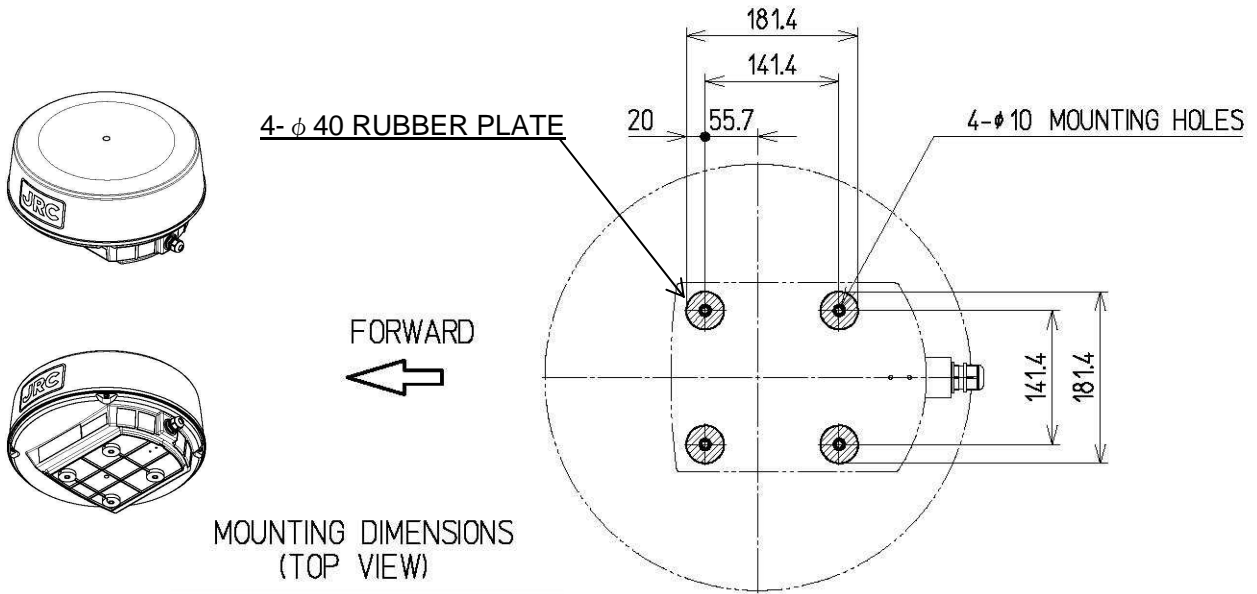

Fig 1-3-6-1

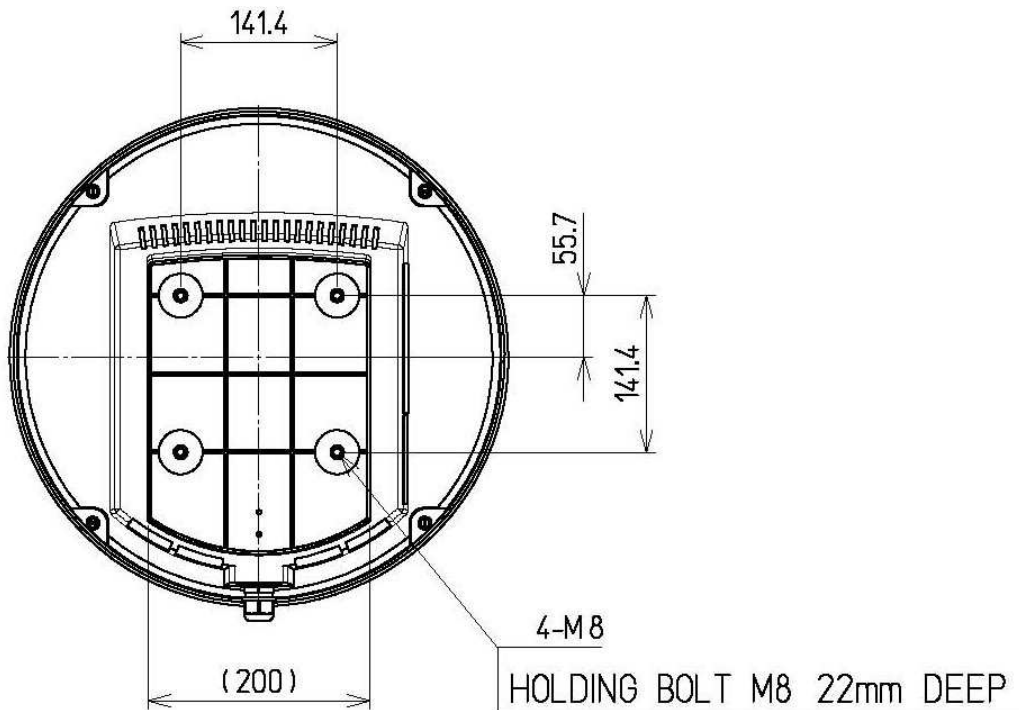

Fig 1-3-6-2

NKE-2044 2 FT SCANNER

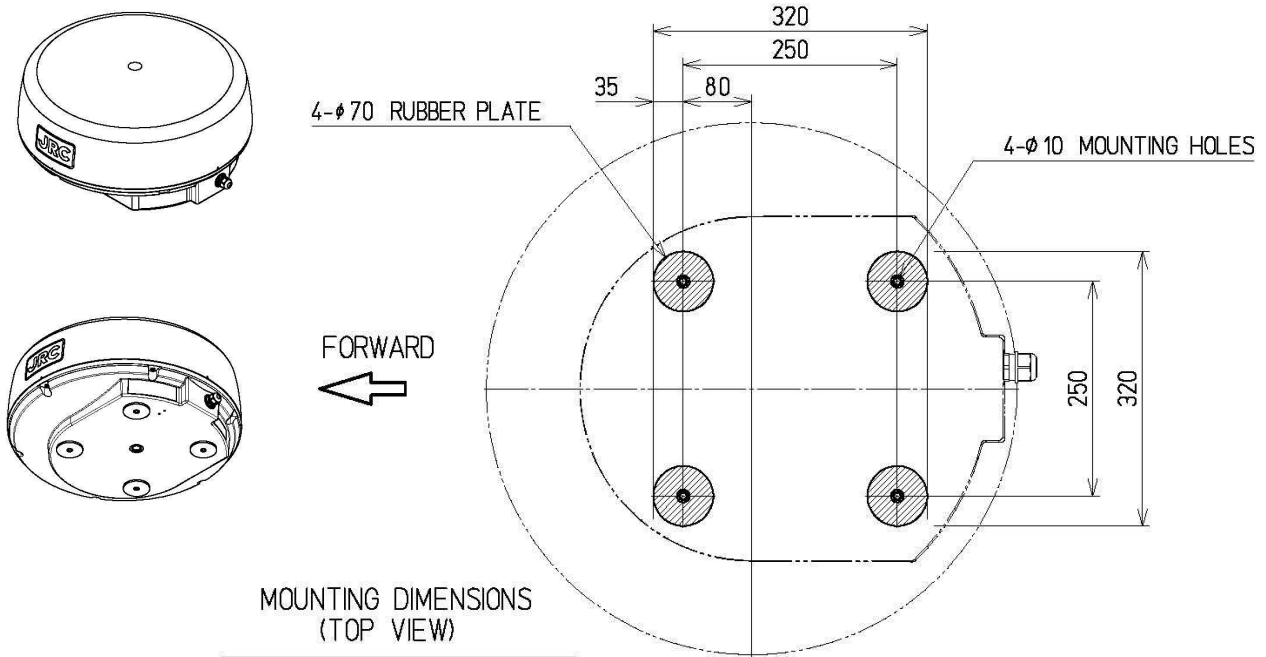

Fig 1-3-6-3

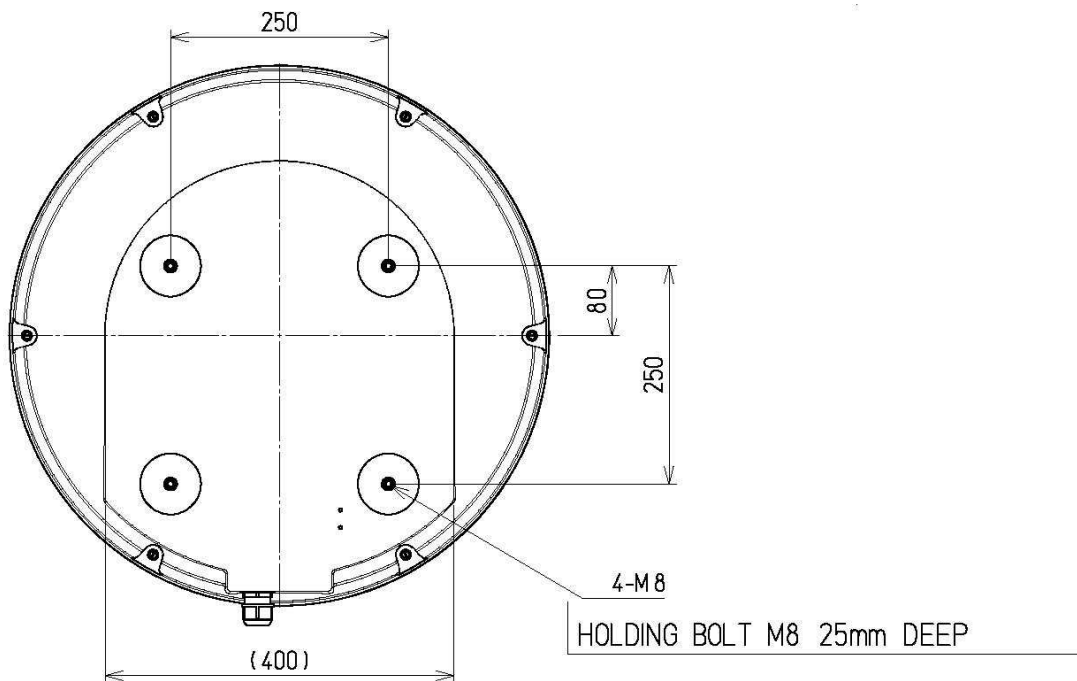

Fig 1-3-6-4

■ Installation and clamping method

■ Installation direction

Installation should be done so that the cable gland is oriented toward the stern.

■ Bolts, nuts and tightening torque to be used

- Use stainless steel bolts for the scanner and uniformly tighten all of the bolts using double nuts for each bolt so that the scanner will not become loose (Table 1-2-1).
- Although the length of the bolt will differ according to the thickness of the mount base, use a bolt long enough so that more than 4 millimeters of thread protrudes beyond the double nuts after the double nuts have been tightened.

Table 1-3-6-1 Length of scanner mounting bolts and tightening torque

Thickness of Mount Base (mm)	Bolt	Torque (N-m)
3-15 mm (Recommend)	M8X30SUS (attachment)	20 N-m

■ Use of washer and corrosion-resistant measures

- At the location where a bolt's head or nut comes in contact with the scanner chassis' legs and the mount base, insert a plain washer which fits the bolt; and, at the location where the nut comes in contact with the plain washer, insert a spring washer, and then securely tighten the nuts .
- To prevent corrosion due to the contacts between different metals, such as the scanner chassis' legs, installation surface, bolts, nuts, etc., cover the bolt's head and nuts with sealant .

■ Grounding and corrosion-resistant measures

- Do not install the scanner in place where puddles are often formed.

1-4 CONNECTING THE INSTALLATION CABLE

Scanner type is selected from two types.

2 ft scanner (NKE-2044) ,and 1.5 ft scanner(NKE-1066).

Both are the radome type, they are no affect from the wind blow.

Because inside microwave radiator is protected by fixed radome.

Even under the strong wind blow conditions, microwave radiator can rotate stable anytime.

The cable's both ends is already processed in factory.

First step, remove radome and connect the cables as follow.

Open cover, and connect as follows.

Display side

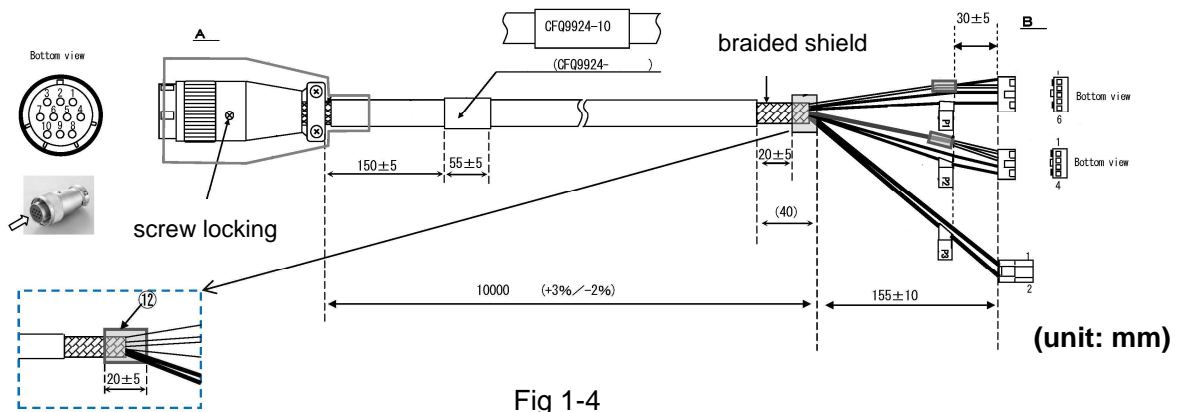
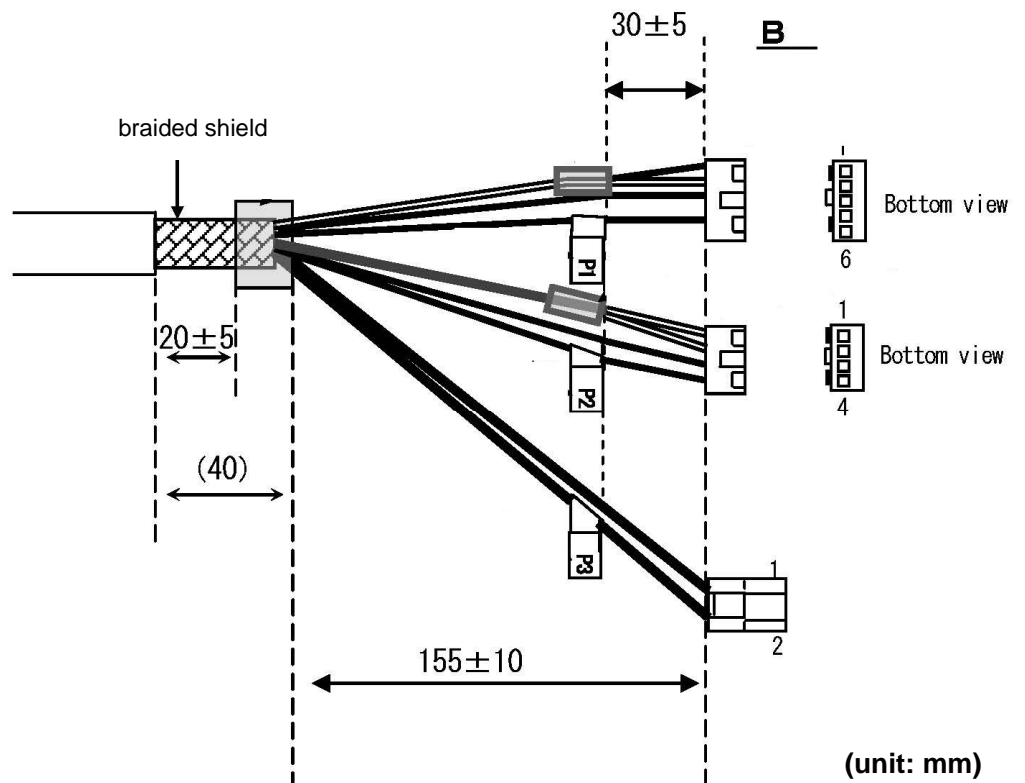

Fig 1-4

Scanner side



1-4-1 NKE-1066 SCANNER(1.5FEET)

Set the cable inlet side to stern.

(Any direction is possible to install and possible to initial setup.

, but it is better selection to select the cable length must be minimize along the mast.)



Fig. 1-4-1-1

1 Open radome

Using box spanner tool, lift up the radome.

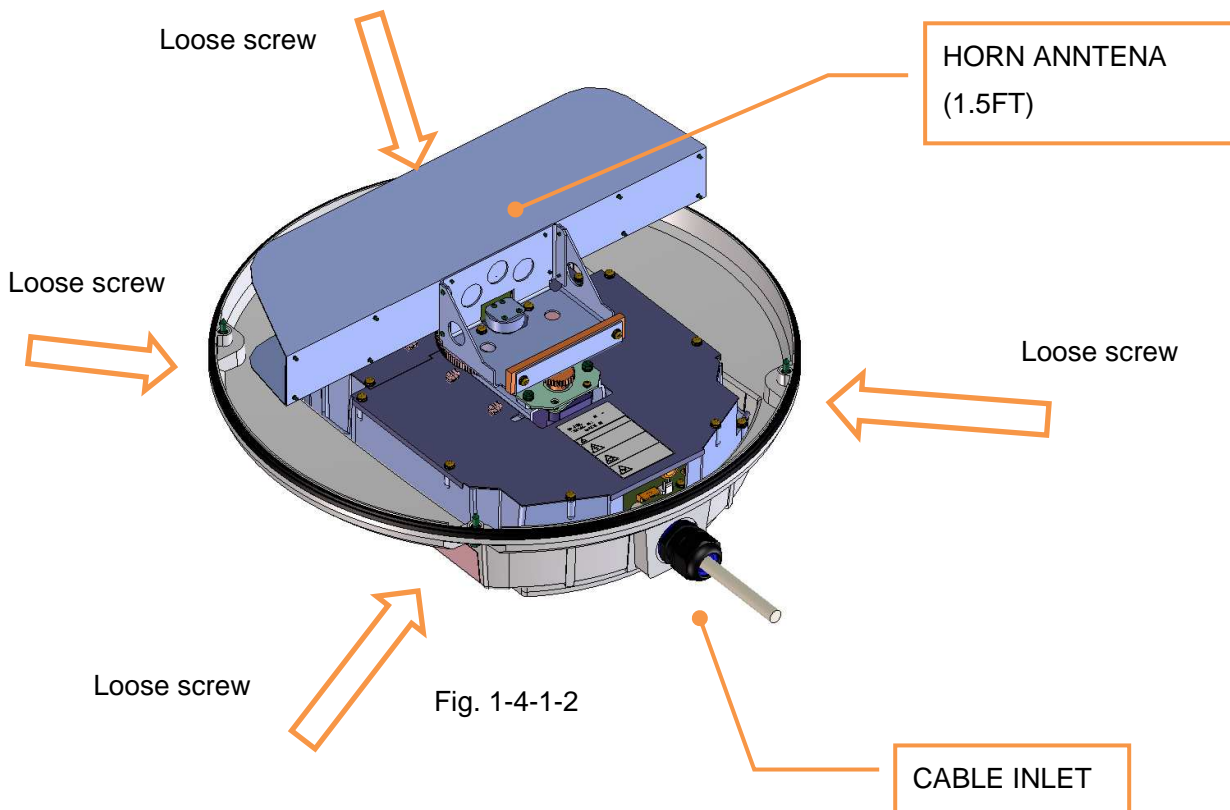

Fig. 1-4-1-2

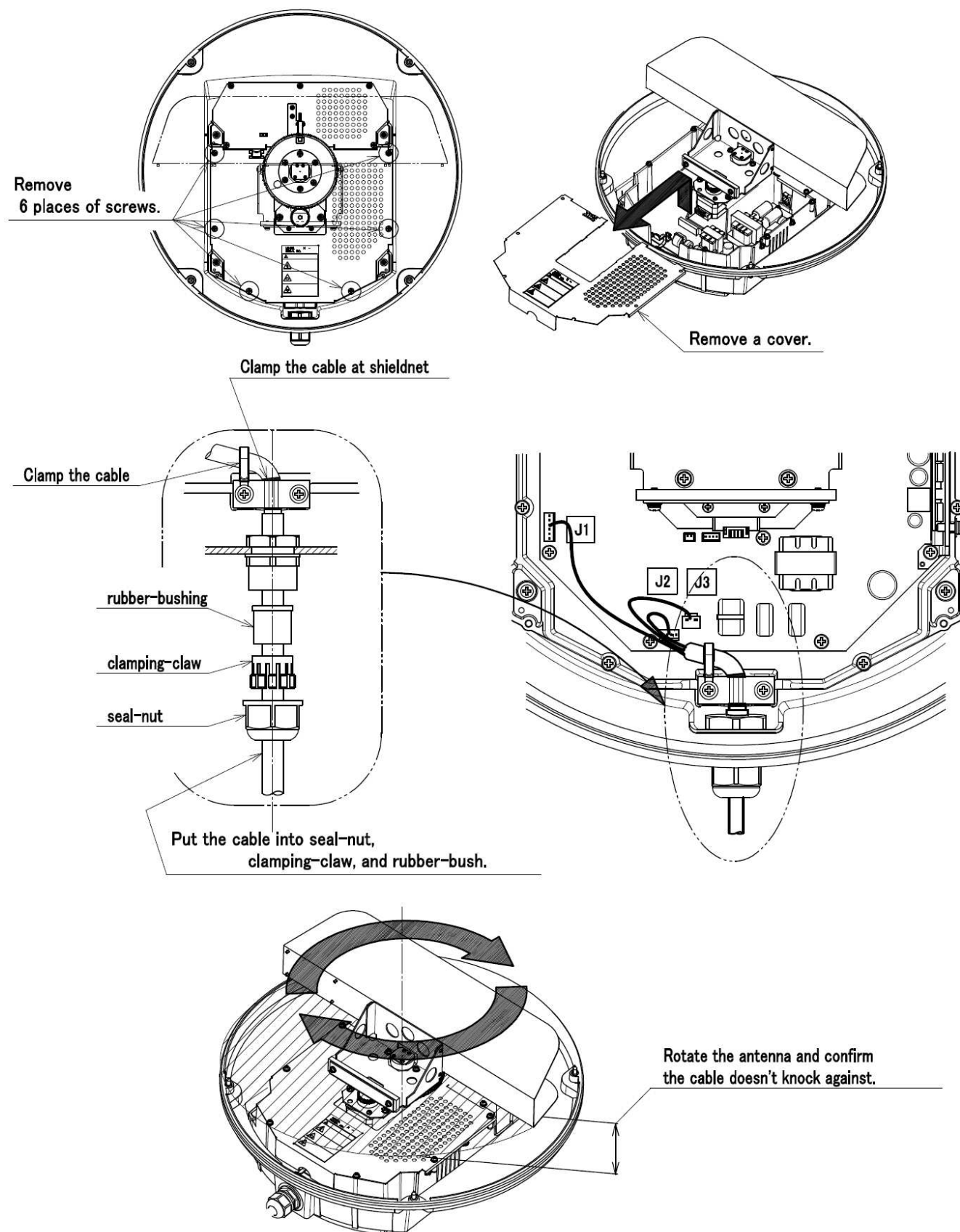

Fig. 1-4-1-3

CAUTION

When mounting the scanner unit, please check the maximum length of the holding bolts.

If the bolts are too long, it gives severe damage to inside of the scanner.

When mounting the scanner unit, please use the attached bolts.

The mounting base thickness must not exceed 15mm(0.6inch).

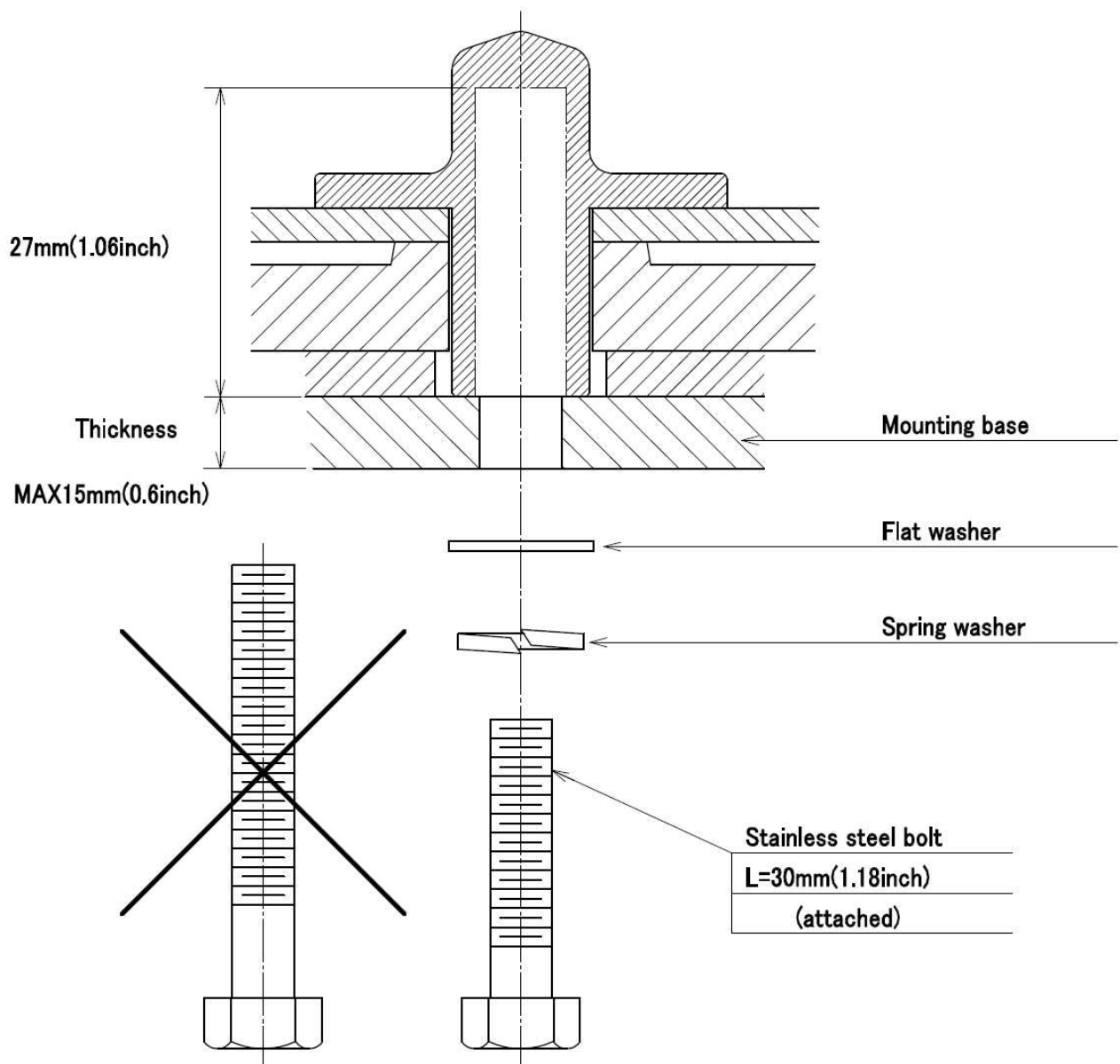

※ FIX THE BOLTS BY USING A STANDARD WRENCH (LENGTH 135mm TORQUE 2058[N·cm])

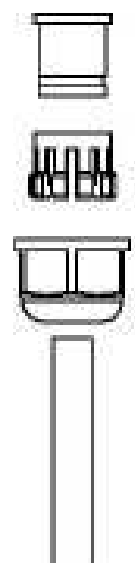
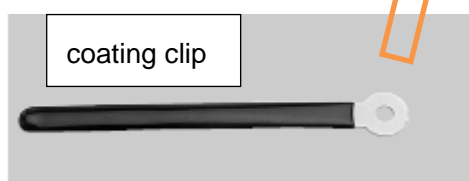
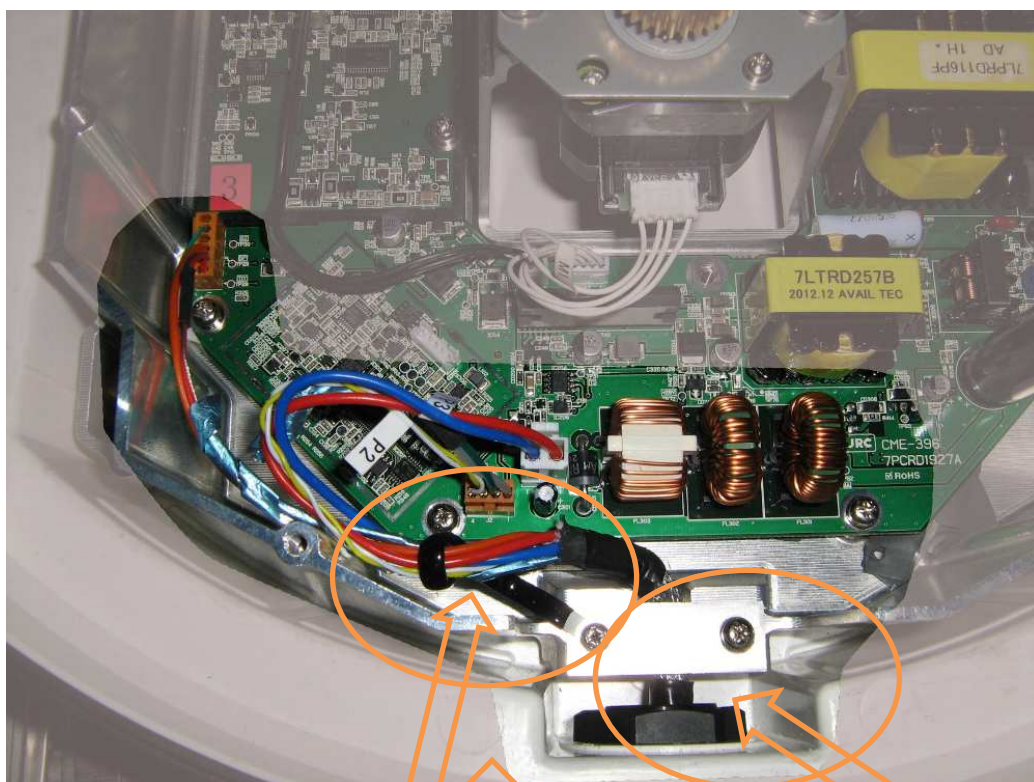

Connect cable's mesh wire as Ground.

Pull and fix the cable toward the outside with coating clip.
(Avoid to touch the cable to electrical parts)

Fig. 1-4-1-4

1-4-2 NKE-2044 SCANNER (2FEET)

Set the cable inlet side to stern.

(Any direction is possible to install and possible to initial setup.

, but it is better selection to select the cable length must be minimize along the mast.)



Fig. 1-4-2-1

1 Open radome

Using box spanner tool, lift up the radome.

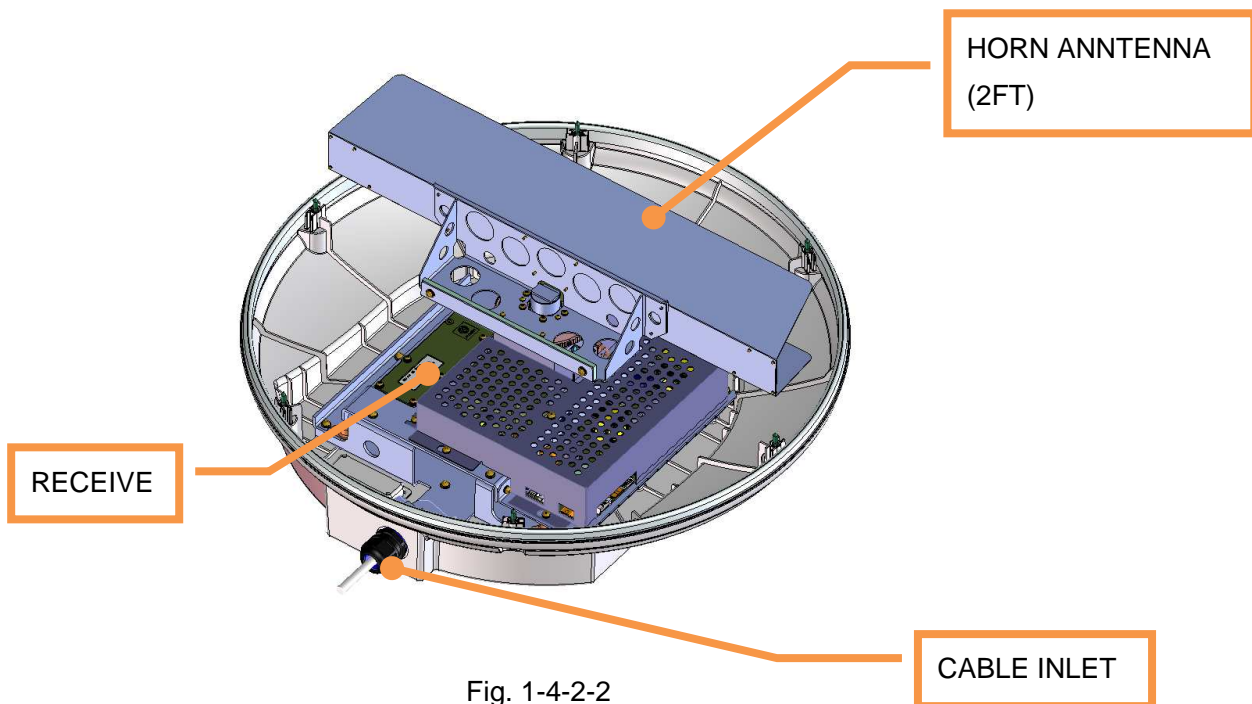

Fig. 1-4-2-2

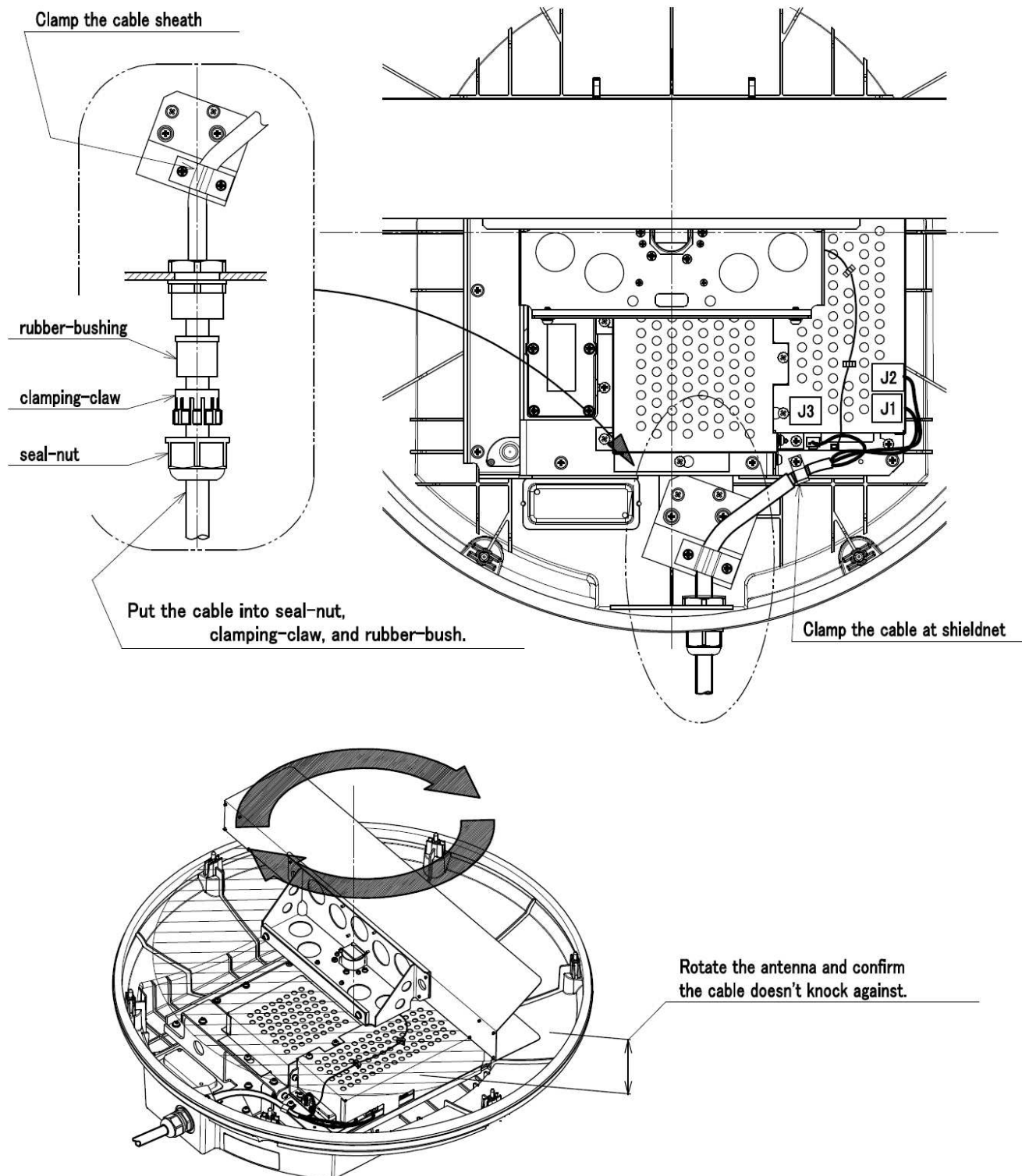
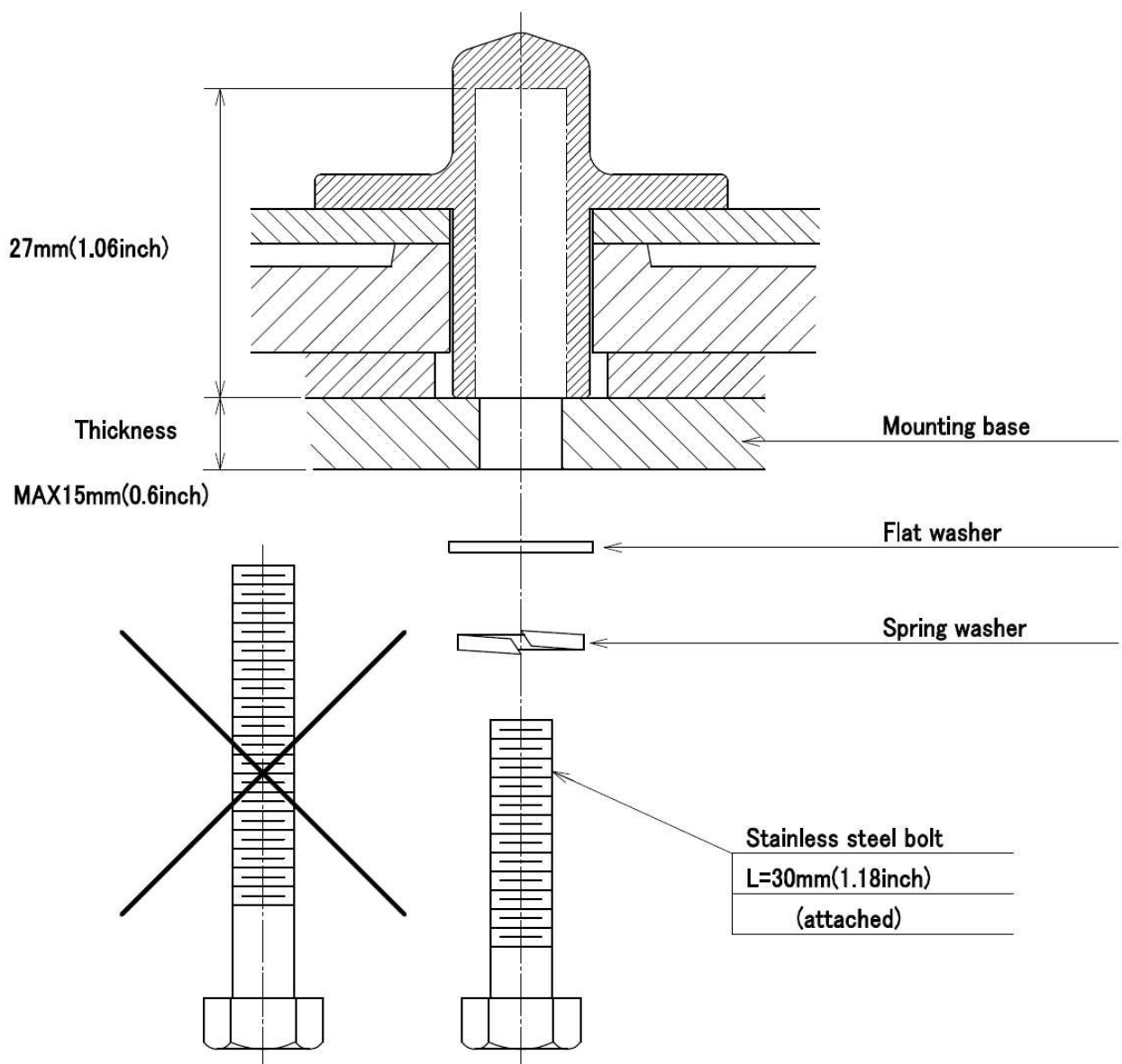

Fig. 1-4-2-3

CAUTION

When mounting the scanner unit, please check the maximum length of the holding bolts.
 If the bolts are too long, it gives severe damage to inside of the scanner.
 when mounting the scanner unit, please use the attached bolts.
 The mounting base thickness must not exceed 15mm(0.6inch).



※ FIX THE BOLTS BY USING A STANDARD WRENCH (LENGTH 135mm TORQUE 2058[N•cm])

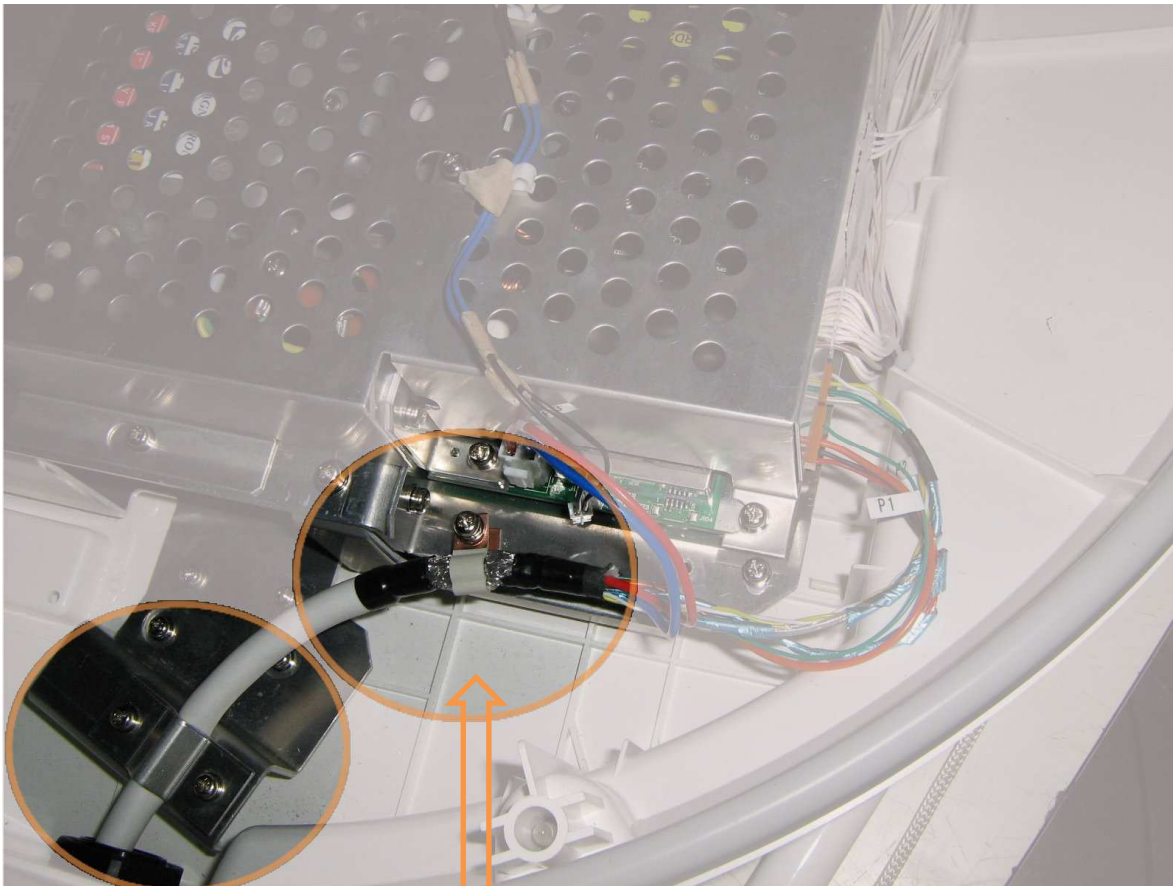

Connect cable's mesh wire as Ground.

Clamp whole cable

Fig. 1-4-2-4