

[2] Relative Vector Mode

The relative vector does not represent the true motion of the target, but its relative relation with own ship. This means that a target with its relative vector directed to own ship (passing through the CPA Limit ring) will be a dangerous target. In the Relative Vector mode, it can be seen at a glance where the CPA Limit of the dangerous target is.

Therefore, the True / Relative mode shall optionally be used for the purpose of observation: the True vector mode for grasping the true aspect of a target, and the Relative vector mode for grasping a target's closest point of approach (CPA).

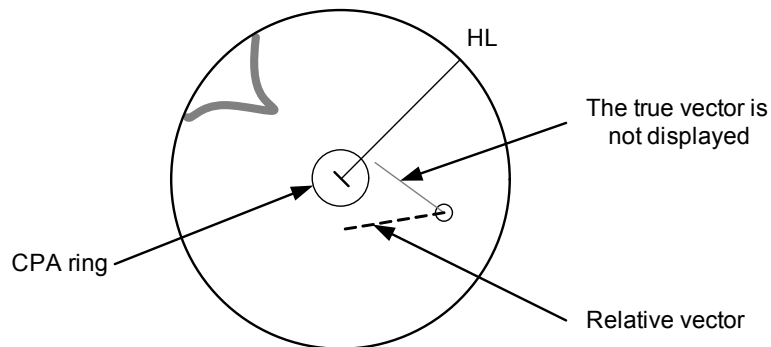

Fig 5-5: Relative Vector

5.1.3.3 Vector Length (Vector Time)

The vector length of a target is proportional to its speed, and the vector time can be switched in a range of 1 to 60 minutes.

The diagram below illustrates a vector length of a target for 6 minutes, and the tip of the vector represents the target's position expected to reach 6 minutes later.

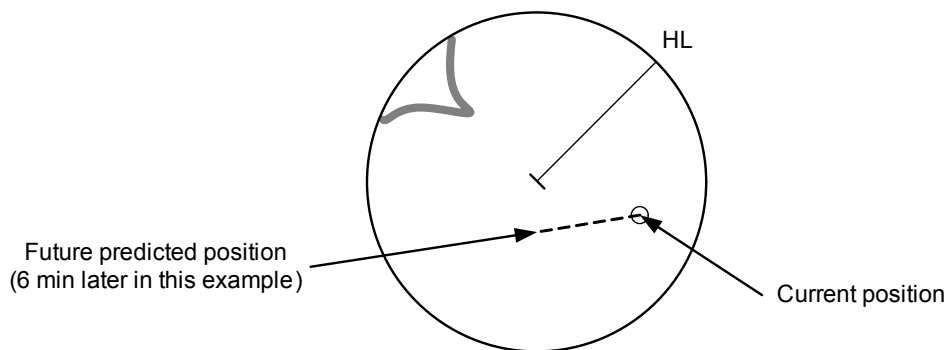

Fig 5-6: Vector Length

Refer to Section 5.1.6 "Setting Vectors (Vector Time)".

5.1.4 Cursor Modes (Cursor)

5.1.4.1 Types and Functions of Cursor Modes

The types of cursor modes are listed in the table below. To use the function of a cursor mode, move the cursor onto the PPI object and left-click.

Mode	Function
ACQ TT	Enables the target tracking function to acquire a target in manual mode.
ACT AIS	Activates AIS targets, and sets a point filter.
TGT Data	Displays the numeric data of a tracking target or AIS target.
CNCL TT	Cancels a tracking target.
DEACT AIS	Deactivates AIS target.
Data CNCL	Hides the displayed numeric data of a tracked target or AIS target.
Mark	Puts a temporary mark.
Property	Displays the information of tracked targets, AIS targets, and marks.
AUTO	Changes operation in accordance with the object at the cursor position.

5.1.4.2 Change of Cursor Mode

Procedures

- 1) **Left-click the Cursor button located at the upper right of the display. Alternatively, on the PPI, right-click and select a desired cursor mode from the list.**

The selected cursor mode will be shown at the cursor mode (Upper right of the display on page 2-4).



If the function of a selected cursor mode is not used for one minute or more, the cursor mode is automatically changed to AUTO .

5.1.4.3 Operation of AUTO Mode

As shown below, the AUTO mode performs operation in accordance with the object at the cursor position when left-clicked.

The AUTO mode permits to access that you want by intuitive operation.

Object at Cursor Position	Operation
None	Acquires a target.
EBL	EBL operation.
VRM	VRM operation.
Intersection point of EBL and VRM	Performs EBL operation and VRM operation at the same time.
Parallel index line	Operates the parallel index line.
Tracked target	Displays the numeric data of the tracked target.
Tracked target with numeric data displayed	Hides the numeric data.
Sleeping AIS target	Activates the AIS target.
Activated AIS target	Displays the AIS target information.
AIS target with numeric data displayed	Hides the AIS target information.
Automatic acquisition / activation zone	Operates the automatic acquisition / activation zone.
AIS filter	Operates the AIS filter zone.

5.1.5 Setting Collision Decision Criteria

Attention

- **Set the optimum values of collision decision conditions, depending upon vessel type, water area, weather and oceanographic conditions. (For the relations between those conditions and alarms, refer to Section 5.5 "ALARM DISPLAY".)**

5.1.5.1 Input of CPA Limit

Procedures

- 1) **Left-click the CPA limit setting button in the Target Information located at the upper right of the display.**

The CPA Limit value input screen will appear.

- 2) **Enter the value to be set as a CPA limit.**

For inputs to the value input screen, refer to Section 3.3.4 "Operation on Numeric Value, Latitude / Longitude and Character Input menu".

5.1.5.2 Input of TCPA Limit

Procedures

- 1) **Left-click the TCPA limit setting button in the Target Information located at the upper right of the display.**

The TCPA Limit value input screen will appear.

- 2) **Enter the value to be set as a TCPA limit.**

For inputs to the value input screen, refer to Section 3.3.4 "Operation on Numeric Value, Latitude / Longitude and Character Input menu".

5.1.5.3 Setting CPA Ring (CPA Ring)

While the distance of the specified CPA Limit value is used as the radius, the CPA ring is displayed with a red circle.

Procedures

- 1) **Left-click the CPA Ring button located at the lower right of the display.**

The CPA ring will be displayed.

NOTE: The CPA ring is not displayed when the true vector mode is selected.

5.1.6 Setting Vectors (Vector Time)

Vector time can be set in minutes in the range 1 to 60 min.

A true vector mode or relative vector mode can be selected.

5.1.6.1 Setting vector time on the display (Vector)

Procedures

- 1) **Left-click the target vector time setting button in the Target Information located at the lower right of the display.**

The Vector Time value input screen will appear.

- 2) **Enter the value to be set as vector time.**

For inputs to the value input screen, refer to Section 3.3.4 "Operation on Numeric Value, Latitude / Longitude and Character Input menu".

5.1.6.2 Setting vector mode [T/R VECT]

Procedures

- 1) **Press the [T/R VECT] key.**

The current vector mode **T** (true vector) or **R** (relative vector) will be displayed in the target vector display true / relative switching in Target Information located at the upper right of the display.

5.1.7 Setting the GPS antenna location

Set the GPS antenna location. Set offset ranges in longitudinal direction and latitudinal direction from the own ship's reference position.

For the setting procedure, refer to Section 7.1.9 "Setting of CCRP (CCRP Setting)".

Attention

- **If offset ranges are not set correctly, AIS symbols and radar echoes may be displayed shifted.**
- **When offset ranges are set, latitude and longitude data received from the GPS is offset, and the offset data is displayed as the latitude and longitude of own ship's position.**

5.2 TARGET TRACKING OPERATION

This section explains how to use the target tracking function.

The target tracking function automatically tracks a target, and displays the target's course and speed as vectors. The target tracking function calculates CPA and TCPA, and issues an alarm as needed.

The tracking data is erased from memory when the power is turned off or during transmission standby.

5.2.1 Acquiring Target [ACQ]

Target acquisition can be performed on two modes, Automatic and Manual, and both modes can be used at the same time.

5.2.1.1 Automatic acquisition

NOTE: If the number of targets being tracked has reached the allowable maximum and other targets (not being tracked) go into the acquisition/activation zone, automatically acquired targets are canceled in ascending order of danger.

The position of the scanner shall be at the centre of the azimuth or range in the acquisition/activation zone.

[1] Turning On / Off the automatic acquisition and AIS activation (AZ Menu)

Procedures

- 1) Open the AZ menu by following menu operations.

AZ

The AZ Menu will appear.

- 2) Left-click the item button of 1. AZ1 or 2. AZ2.

The acquisition / activation zone 1 (AZ1) or acquisition / activation zone 2 (AZ2) will be set to on or off.

On

:The acquisition / activation zone is turned on. The mark \bigcirc_{12} and target ID number are put to an acquired target and move with the target. The vectors are displayed within 1 minute. AIS targets are activated.

Off

:The acquisition/activation zone is turned off. The acquisition/activation zone will disappear from the radar display, but the system continues to track the acquired target. The activated AIS targets remain activate.

[2] Creating the automatic acquisition and AIS activation Zone (Make AZ)

Procedures

- 1) **Open the AZ menu by following menu operations.**

AZ

= 捕捉・活性化メニュー (AZ Menu) が開きます。

- 2) **Left-click the item button of 3. Make AZ1 or 4. Make AZ2 .**

The range setting of the acquisition / activation zone 1 (AZ1) or acquisition / activation zone 2 (AZ2) will be started.

- 3) **Set the starting azimuth and range by turning the [EBL] dial and [VRM] dial, and left-click.**
- 4) **Set the ending azimuth and range by turning the [EBL] dial and [VRM] dial, and left-click.**

The acquisition / activation zone will be determined.

5

5.2.1.2 Manual Acquisition [ACQ MANUAL]

NOTE: If more targets are acquired manually in the condition that the maximum number of targets are under tracking, the targets cannot be acquired.

Procedures

- 1) **Move the cursor onto the target to be acquired, and press the [ACQ MANUAL] key.**

The target will be acquired and the initial acquisition symbol will be displayed.

The vector will be displayed within one minute.

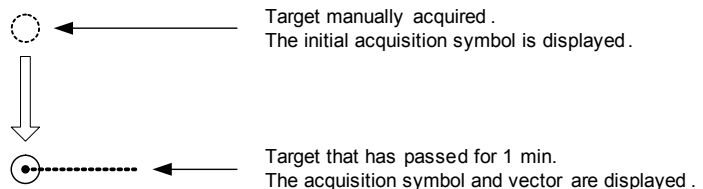

To perform operation only in the manual acquisition mode without automatic acquisition/activation, turn off the automatic acquisition/activation function.

[1] Use of Automatic and Manual Acquisition Modes

Use the manual acquisition mode while the automatic acquisition mode is on.

Manually acquire the target to which particular attention should be paid, and get the other targets automatically acquired. If a new target appears exceeding the maximum number of targets, the manually acquired target is displayed even in the background until it gets out of the display. However, automatically acquired targets are canceled starting far distance from own ship.

5.2.2 Canceling Unwanted Tracked Targets [ACQ CANCEL]

Unwanted tracked targets can be canceled one by one in the following cases:

- Tracking is no longer necessary for targets with which vectors/symbols are displayed after being acquired and tracked.
- The number of vectors on the radar display needs to be reduced for easy observation.

When targets are to be re-acquired from the beginning, all the current vectors can also be canceled.

5.2.2.1 Canceling targets one by one [ACQ CANCEL]

Procedures

- 1) Put the cursor on the tracked target to the desired for canceling target, and press the [ACQ CANCEL] key.

The vectors and symbols of the tracked targets will disappear, and only the radar video remain.

5.2.2.2 Canceling all targets collectively [ACQ CANCEL]

Procedures

- 1) Press the [ACQ CANCEL] key for 5 seconds.

The vectors and symbols of all the targets will disappear, and only the radar videos remain.

NOTE: When all the targets have been canceled, the system stops tracking them. Thus, you need to re-acquire targets in manual or automatic acquisition mode. Do not cancel all the targets unless otherwise required.

5.2.3 Tracked Target Data Display [TGT DATA]

Attention

When a target or own ship changes its course, or when a new target is acquired, its vector may not reach a given level of accuracy until 3 minutes or more has passed after such course change or target acquisition.

Even if 3 minutes or more has passed, the vector may include an error depending upon the tracking conditions.

5.2.3.1 Type of Data Display (Target Information)

Target Data	
Target identification (TT ID)	ID number of the target
True bearing(BRG)	0.1° unit
Range	0.01NM unit
Course	0.1° unit
Speed	0.1knot unit
Closest point of approach (CPA)	0.01NM unit
Time to CPA (TCPA)	0.1min unit
Bow crossing range (BCR)	0.01NM unit
Bow crossing time (BCT)	0.1min unit

The target for which its numeric data is displayed is marked with a symbol $\text{⊙}_{12}^{\text{---}}$ to distinguish from other targets.

If a target's data is displayed, but without the symbol $\text{⊙}_{12}^{\text{---}}$, such a target exists outside the currently displayed radar display.

5.2.3.2 Method of Displaying Numeric Data [TGT DATA]

Procedures

- 1) **Put the cursor on the tracked target for which numeric data is to be displayed, and press the [TGT DATA] key.**

Then, the data of the designated target will appear, it will be marked with a symbol $\text{⊙}_{12}^{\text{---}}$. The target data will remain on the radar display until the target is lost and its vector disappears, or until another target is designated.

If a target with the mark ○_{12} is designated, only its true bearing and range will appear until its vector appears.

5.2.3.3 Cancellation of Numeric Data Display (CNCL Data)

Procedures

- 1) **Put the cursor on the tracked target with which numeric data is displayed, and right-click.**

The cursor mode list will appear.

- 2) **Left-click  button.**

The numeric value will disappear.

5.2.4 Displaying Target ID No.(Target Number Display)

A target ID number is a value displayed beside the acquisition symbol when a target is acquired.

A target ID number 1 to 100 is assigned to each target in acquisition order. Once a target ID number is assigned, it identifies the target until the target is lost or the target acquisition is canceled.

Procedures

- 1) **Open the TT Menu by following menu operation.**



- 2) **Left-click the item button of .**

Target Number Display will appear.

- 3) **Press the [numeric] key corresponding to the display method to be set.**

 : Displays target ID numbers.

 : Hides target ID numbers.

 : Displays target ID number with target track.

If there are many tracking targets and their symbol display is confusing, set Target Number Display to off to view the radar display easily.



An ID number is always displayed for only targets with which numeric data is displayed.

5.2.5 Adding Tracked Target ID Name (Name)

The system can enter a name for each of tracking targets that have been acquired.

Procedures

- 1) **Put the cursor on the tracked target, and right-click.**

The cursor mode list will appear.

- 2) **Left-click** 

The Property will appear.

- 3) **Left-click the item button of**  .

The setting items for ship name (Name) will be displayed.

- 4) **Select the input method.**

 **Data Base**

:Selection of one of previously input ship names. When this method is selected, a list of ship names that have been input by selecting  will be displayed.

 **Input**

:Input of a new ship name. When this method is selected, the ship name (Name) input window will open.

5.2.5.1 Entering a new ship name (Input)

- 5) **Input a new ship name.**

Up to 8 characters can be input as a ship name. For the input method on the character input screen, see Section 3.3.4.7 "Entering a character".

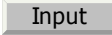
The input name by selecting  is saved in **Data Base** .

5.2.5.2 Selecting one of previously input ship names (Data Base)

- 5) **Press the [numeric] key corresponding to the ship name to be selected.**

The selected ship name will be entered.



Data Base can contain 30 ship names.

5.2.6 Reference Target (Reference)

The system can display the own ship's speed. To do so, it sets a reference target by tracking a target for which ground fixed.

Attention

- The reference target function is to be used if the own ship's speed cannot be displayed normally due to trouble such as a speed sensor malfunction. Do not use the reference target function except in emergencies.
- If the speed or course of the own ship is changed or a new reference target is set, the displayed speed may take 3 minutes or more to reach the specified speed after the speed / course change or the setting.
- Even after 3 minutes or more has passed, the speed may differ from the specified speed depending on the tracking condition.
- If a large radar echo such as a land target is set as a reference target, the vectors of the speed and other tracking targets will not be displayed correctly and may cause an accident.
- If a sailing ship is set as a reference target, the vectors of the speed and other tracking targets will not be displayed correctly and may cause an accident.
- If the **REF.** is selected for the speed sensor, the AIS function cannot be turned on.
- If the reference target is lost or the target tracking function is stopped, the speed sensor is placed in manual mode **MAN**.
- The loss of a reference target may have a major impact on the accuracy of the results for true speed and true course of the target and that own speed will be degraded.
- The reference targets are only used for the calculation of true speed.

Procedures

- 1) Tracking a target for which ground fixed.
- 2) Put the cursor on the tracked target, and right-click.

The cursor mode list will appear.

3) **Left-click** 8. Property

The Property will appear.

4) **Left-click the item button of** 3. Reference

The reference target function will be set to on or off.

On :A reference target is set.

Off :The reference target is canceled.

5) **Left-click the speed sensor switching button in the Own Ship Information located at the upper right of the display, and select** REF. .

The speed of own ship calculated from the reference target will be displayed.

When a reference target is set, the symbol display is changed to .

Only one target can be set as a reference target. When a new reference target is set, the previously set reference target is canceled.

5.2.7 Operation Test (TT Test Menu)



CAUTION



This function is provided to test if the target tracking function is operating normally. Thus, do not use the function except when you test the target tracking function.

In particular, if the operation test mode is used during navigation, pseudo targets appear on the radar display and they are confused with actual targets.

Do not use the mode during navigation. Otherwise, an accident may result.

The following functions are available for testing the target tracking function:

- | | |
|--------------|---|
| Test Video | Makes an operation check on the target detection circuit. |
| TT Simulator | Generates pseudo targets on the radar display in order to test if the target tracking function is operating normally. |
| Status | Displays the status of the target tracking function. |
| Gate Display | Displays the gate size for acquiring / tracking a target. |

5.2.7.1 Test Video (Test Video)

Test Video is used to check whether the video signals under target acquisition and tracking are inputted to and processed in the target detection circuit normally.

However, it is sufficient to check that VDH in Test Video is displayed.

NOTE: Test Video may not be displayed for a target which is not yet acquired or tracked. Test Video may not be displayed either if the [GAIN] dial or [SEA] dial is not properly adjusted.

Procedures

- 1) **Open the TT test menu by following menu operation.**

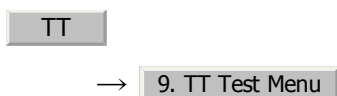

- 2) **Left-click the item button of 1. Test Video .**

The setting items for Test Video will be displayed.

- 3) **Select the test video to be displayed.**

In general, **VDH** is sufficient for target display checks in test video mode.

 If any target displayed clearly in the radar display is not displayed in the Test Video mode, the target detection circuit of the Target Tracking unit may have a trouble.

Cancel

- 1) **Left-click the item button of 1. Test Video while the TT Test Menu is displayed.**

The setting items for Test Video will be displayed.

- 2) **Left-click **Off** button.**

The test video display will be turned off.

5.2.7.2 Target Tracking Simulator (Target Tracking Simulator)

Pseudo targets can be generated in certain known positions to check whether the target tracking units are operating normally. Since the pseudo targets move depending on known parameters, the values for these pseudo targets can be compared with the known value if the pseudo targets are acquired and tracked, and displayed. Thus, it can be checked if the system is operating normally.

Procedures

- 1) **Press the [TX/STBY] key to stop the transmitting.**

The equipment will enter the transmission standby state.

- 2) **Open the TT Test Menu by performing the following menu operation.**

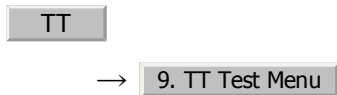

- 3) **Left-click the item button of 2. TT Simulator .**

The setting items for TT Simulator will be displayed.

- 4) **Select the scenario to be set.**

- 5) **Press the [TX/STBY] key to transmit.**

The simulator will be activated and generate pseudo targets. The characters "X" at the bottom of the radar display blinks indicating that the simulation mode is active.

Target tracking simulator / scenario

Scenario	Target start point		Target end point		Pseudo-target speed
	Distance	Bearing	Distance	Bearing	
1	3.2NM	20°	1NM	90°	20kn
2	6NM	0°	0NM	0°	10kn
3	6NM	18° every	1NM	18° every	10kn
4	6NM	45°	1NM	45°	105kn
5	6NM	45°	6NM	150°	20kn
6	6NM	45°	6NM	150°	20kn



When the simulator is operating, set 0° as the heading bearing, and 0 kn as the speed of own ship. When the range between own ship and the pseudo target is 0, the target will disappear.

Exit

- 1) **Press the [TX/STBY] key to stop the transmitting.**

The equipment will enter the transmission standby state.

- 2) **Left-click the item button of 2. TT Simulator while the TT Test Menu is displayed.**

The setting items for TT Simulator will be displayed.

- 3) **Left-click Off .**

The TT Simulator display will be turned off.

5.2.7.3 Status display (Status)

The current Target Tracking status will appear.

Procedures

- 1) **Open the TT Test Menu by performing the following menu operation.**

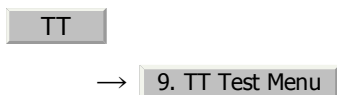

- 2) **Left-click the item button of 3. Status .**

The setting items for Status will be displayed.

*Constant : Vector response

*VID Level TD : Threshold value used for automatic acquisition

*VID Level HIGH : Threshold value used for tracking

*VID Level LOW : Unused

*Gate Size : Size of gate used for tracking

*Tracking : Number of targets currently acquired

5.2.7.4 Gate Display

The gate displays an area monitoring a target using the Target Tracking function. This radar equipment allows the gate size to change automatically according to target range and size. User can check the gate size using the following function.

Procedures

- 1) **Open the TT Test Menu by performing the following menu operation.**

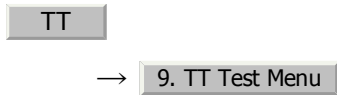

- 2) **Left-click the item button of 4. Gate Display .**

The gate display mode is switched.

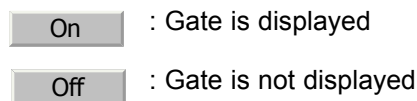

- 3) **Display the numeric value of a target according to Section 5.2.3 "Tracked Target Data Display [TGT DATA]" .**

The numeric value of the target will be displayed, and the tracked target symbol will be enclosed in a green gate.



The Target Tracking can display the gate of two targets simultaneously.

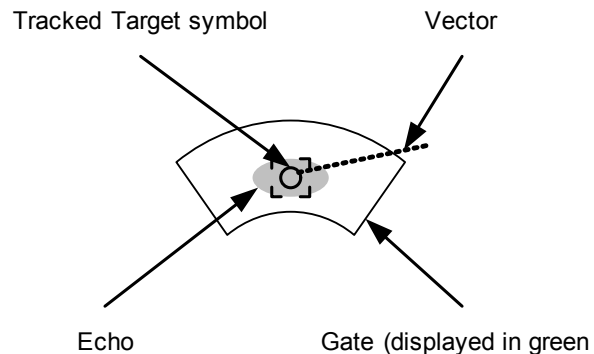

5.3 AIS OPERATION

5.3.1 Restrictions

The following restrictions are placed on use of the AIS function.

The AIS function is unavailable in the following cases:

- **MAN** or **REF.** is selected for the speed sensor. The current offset (Set/Drift Setting) is set while **LOG** or **2AXW** is selected for the speed sensor.

LOG or **2AXW** cannot be selected for the speed sensor in the following case:

- The AIS function is turned on and the current offset (Set/Drift Setting) is selected.

MAN cannot be selected for the speed sensor in the following case:

- The AIS function is On.

Current offset (Set/Drift Setting) cannot be turned On in the following case:

- **LOG** or **2AXW** is selected for the speed sensor while the AIS function is on.

5.3.2 Setting AIS Display Function (AIS Function)

Attention

- When the AIS function is set to Off, the AIS display function is turned off and AIS symbols are no longer displayed.
- Once the AIS display function is set to Off, it is not automatically switched to On even if a dangerous target exists.

Procedures

- 1) Press the [AIS/TT] key. Alternatively, left-click the **AIS** button in the Target Information located at the upper right of the display.

The received AIS information will be shown on the radar display.

5.3.3 Activate AIS Targets (Activate AIS)

Activate an AIS target, and display the target's vector and make a collision decision.

5.3.3.1 Manual activation (ACT AIS)

Activate an AIS target in manual mode to display the vector and heading line.

Procedures

- 1) Put the cursor on the AIS symbol to be activated, and right-click.

The setting items for cursor modes will be displayed.

- 2) Left-click **2. ACT AIS**.

The selected AIS target will be activated.

5.3.3.2 Automatic activation

Activate an AIS target in automatic mode to display the vector and heading line.

When the automatic activation function is used, AIS targets are automatically activated when they go into the automatic activation zone. The automatic activation zone is identical to the automatic acquisition zone (AZ) used for target tracking. For the zone setting, refer to Section 5.2.1 "Acquiring Target [ACQ]"

The position of the scanner shall be at the centre of the azimuth or range in the acquisition/activation zone.

If there are more AIS targets than the allowable maximum, they are deactivated in the low-priority (See the Section 5.1.2 "Definitions of Symbols").



If an AIS target is activated but the vector is not displayed, refer to Section 5.3.6 "Displaying Target ID No. (Target Number Display)".

5.3.4 Deactivate AIS Targets (Deactivate AIS)

Deactivate an AIS target and clear the display of the vector and heading line.

Procedures

- 1) Put the cursor on the AIS target to be deactivated, and right-click.

The setting items for cursor modes will be displayed.

- 2) Left-click **5. DEACT AIS**

The selected AIS target will be deactivated.



This operation is available only for an activated AIS target.

5.3.5 Displaying AIS Information [TGT DATA]

5.3.5.1 Types of information displayed

There are two modes (simple and detail) to display AIS target information. The display items are determined by the selected mode.

Display Item	Detail mode	Simple mode
NAME (ship name)	Up to 20 characters	
Call Sign	Up to 7 characters	
MMSI	Up to 9 characters	
COG (course over ground) or CTW (course through water)	0.1° unit	
SOG (speed over ground) or STW (speed through water)	0.1kn unit	
CPA (closest point of approach)	0.01NM unit	
TCPA (time to CPA)	0.1min unit	
BRG (true bearing)	0.1° unit	Not displayed
Range	0.01NM unit	
HDG (heading bearing)	0.1° unit	
ROT (rate of turn)	0.01° /min	
POSN (latitude / longitude)	0.001' unit	
Destination (waypoint)	Up to 20 characters	
NAV Status	Status (number)	

The detail mode displays the numeric data of only a single ship, the simple mode can display the numeric data of up to two ships.

For NAV Status, one of the following statuses is displayed in accordance with Navigation Status:

No.	Status
0	Under Way Using Engine
1	at Anchor
2	Not Under Command
3	Restricted Manoeuvrability
4	Constrained by Her Draft
5	Moored
6	Aground
7	Engaged in Fishing
8	Under Way Sailing
9	Reserved
10	Reserved
11-14	Reserved
15	Not Defined

5.3.5.2 Displaying AIS Target Information [TGT DATA]

Procedures

- 1) Put the cursor on the AIS target of which information is to be displayed , and press the [TGT DATA] key.

The information of the selected AIS target will be displayed.

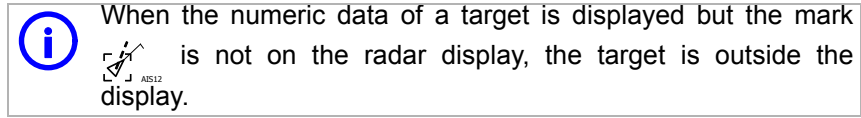

5.3.5.3 Canceling AIS Target Information Display (CNCL Data)

Procedures

- 1) Put the cursor on the activated AIS target of which information display is to be cancelled, and right-click.

The setting items for cursor modes will be displayed.

- 2) Left-click **6. CNCL Data** .

The information display of the selected AIS target will be cleared.

5.3.5.4 Selecting Detail / Simple Mode for AIS Target Information Display

Procedures

- 1) Left-click the or button in the Digital Information located at the center right of the display.

The detail or simple mode display for AIS target information will be selected.

5.3.5.5 Message

Received AIS messages can be displayed.

Up to 10 messages of addressed message and up to 10 messages of broadcast message can be displayed.

If the number of messages exceeds 10, the oldest received messages are sequentially deleted.

[1] Displaying Message Selected from List (Message)

Procedures

- 1) Open the Message menu by performing the following menu operation.

AIS

→ 9. TT Test Menu

- 2) **Left-click** Addressed Message **or** Broadcast Message .

Addressed messages list or broadcast messages list are displayed.

Each list shows ship names and message-received time.

For an unread message, * is displayed to the left of the item number.

- 3) **Left-click the item button to display the message.**

The message will appear.

[2] Displaying Specified Target's Message

Procedures

- 1) **Display AIS target information.**

If there are messages from the target, a message mark will be displayed in the Digital Information located at the center right of the display.

- 2) **Left-click the unread message display button in the Digital Information located at the center right of the display.**

The message will appear.

[3] Deleting Message (Delete)

Procedures

- 1) **Left-click** 1. Delete **while the message is displayed.**

The Confirmation Window will appear.

- 2) **Left-click** 1. Yes **to delete the message.**

The message will be deleted, and the ship name and message-received time will disappear from the list.

5.3.5.6 Displaying Data of Lost AIS Target (Display Lost TGT Data)

The data of the last-lost AIS target can be displayed.

The data of only one target that has been lost most recently can be displayed.

Procedures

- 1) Open the Display Lost Target Data menu by performing the following menu operation.

AIS

→ 8. Display Lost Target Data

The data of the last-lost AIS target will be displayed.

5.3.5.7 Displaying Own Ship's AIS Data (Own Ship's AIS Data)

The AIS data of own ship can be displayed.

Procedures

- 1) Open the Own Ship's AIS Data menu by performing the following menu operation.

AIS

→ 9. Own Ship's AIS Data

The own ship's AIS data will be displayed.

5.3.6 Displaying Target ID No. (Target Number Display)

When an AIS target is activated, a target ID number is displayed next to the AIS target symbol.

A target ID number 1 to 100 is assigned to each target in activation order. Once a target ID number is assigned, it identifies the target until the target is lost or deactivated.

Procedures

- 1) Open the Target Number Display menu by performing the following menu operation.

AIS

→ 4. AIS Filter Setting

- 2) **Left-click the item button corresponding to the display method to be set.**

On : Displays target ID numbers.

Off : Hides target ID numbers.

Target Track : Displays target ID number with AIS track.

Ship's Name : Displays the ship's name.

If there are many tracking targets and their symbol display is confusing, set Target Number Display to off to view the radar display easily.



An ID number or ship's name is always displayed for only targets with which numeric value is displayed.

5.3.7 Setting AIS Filter (AIS Filter Setting)

5.3.7.1 About an AIS filter

By setting an AIS filter, an AIS target in the area can be displayed by priority or only the targets in the area can be displayed. An AIS filter is initially set in a circle having a radius of 20 [nm] from the CCRP. If 301 or more AIS targets exist in the filter range, they are displayed in the priority order explained in Section 5.1.2 "Definitions of Symbols".

5.3.7.2 Types of AIS Filters (Filter Type)

There are the following 3 types of AIS filters:

Range : A filter is set in a circle with a set range as the radius.

Sector : A filter is set in a sector formed by two bearings with the bow as reference.

Zone : A filter is set in a zone formed by two bearings and two ranges with the bow as reference.

Procedures

- 1) **Left-click the AIS filter mode switching in Target Information located at the upper right of the display, and select the filter to be set.**

The AIS filter will be selected.

5.3.7.3 Creation of AIS Filter (Make AIS Filter)

Procedures

- 1) Open the AIS Filter Setting menu by performing the following menu operation.



- 2) Left-click **2. Make AIS Filter**.

The mode to make an AIS filter will be activated.

[1] Setting Range Filter

- 3) Set a filter range by turning the [VRM] dial, and left-click.

[2] Setting Sector Filter

- 3) Set a starting bearing by turning the [EBL] dial, and left-click.
- 4) Set an ending bearing by turning the [EBL] dial, and left-click.

[3] Setting Zone Filter

- 3) Set a starting bearing and range by turning the [EBL] dial and [VRM] dial, and left-click.
- 4) Set an ending bearing and range by turning the [EBL] dial and [VRM] dial, and left-click.



When the automatic activation function is enabled, the filter range is automatically changed for covering the automatic activation zone. Thus, the automatic activation zone is always within the filter range.

5.3.7.4 AIS Filter Display On/Off (Filter Display)

Procedures

- 1) Open the AIS Filter Setting menu by performing the following menu operation.



- 2) Left-click the item button of **3. Filter Display** .

Filter Display will be set to on or off.

5.3.7.5 Display of Targets outside AIS Filter (Filter Mode)

Procedures

- 1) Open the Filter Mode menu by performing the following menu operation.



- 2) Left-click the item button of **6. Filter Mode** .

Display : Displays only AIS targets in the AIS filter.

Priority : Displays AIS targets in the AIS filter by priority, and also displays targets outside the AIS filter.



Activated AIS targets can be displayed even when they are outside the AIS filter.

5.3.7.6 Point Filter

AIS targets which are not displayed because they are outside the AIS filter or at low priority levels can be activated by giving a higher priority to them.

Procedures

- 1) **Put the cursor on the position where a point filter is to be set, and right-click to select the filter to be set.**

The setting items for cursor modes will be displayed.

- 2) Left-click .

A point filter will be set at the cursor position.

If an AIS target is in the point filter, it will be activated.

When an AIS target is activated or an AIS target is not found within one minute, the point filter will be cleared.



The point filter's range is 1 nm, and cannot be changed.

5.3.8 Conditions for Deciding AIS Target to be Lost

About a lost target

When the data of an AIS target cannot be received for a specified time, the target is decided to be lost and the target data is deleted. As shown in the table below, the time until target data is deleted varies depending on the class of receive data and the target status.

Deciding AIS Target to be Lost

Target status	Time until data deletion	
	SOLAS ship (Class A)	SOLAS ship (Class B)
Vessel below 3 knots (Class A) or 2 knots (Class B) and it is now at anchor or on the berth	18 min	18 min
Vessel of 3 knots or more and it is now at anchor or on the berth	60 sec	18 min
Vessel of 0 to 14 knots (Class B: 0 to 14 knots)	60 sec	180 sec
Vessel of 14 to 23 knots	36 sec	180 sec
Vessel of 23 knots or more	30 sec	180 sec



When a dangerous target ship is lost, a lost alarm is issued and the symbol changes to a lost symbol. The system calculates the current position from the last-received data and continues displaying the symbol for eternity.

If the [ALARM ACK] key is pressed, the symbol is cleared.

5.3.9 Setting Conditions for AIS Alarm (AIS Alarm Setting)

Conditions for issuing a Lost alarm and CPA/TCPA alarm for AIS targets can be set.

5.3.9.1 Setting of Condition for Lost Alarm

Procedures

- 1) Open the AIS Alarm Setting menu by performing the following menu operation.

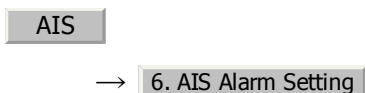

- 2) Left-click the item button of **1. Lost Alarm**.

The setting items for Lost Alarm will be displayed.

- 3) Left-click the item button corresponding to the condition to be set.

Off : A lost alarm is not issued.

Danger : A lost alarm is issued only for AIS targets for which a dangerous target alarm has been issued.

ACT&Danger : A lost alarm is issued only for activated AIS targets and AIS targets for which a dangerous target alarm has been issued.

 A lost alarm is not issued for sleeping AIS targets.

5.3.9.2 Setting of Condition for CPA/TCPA Alarm

Procedures

- 1) Open the AIS Alarm Setting menu by performing the following menu operation.

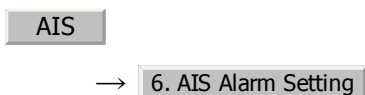

- 2) Left-click the item button of **CPA/TCPA Alarm**.

The setting items for CPA/TCPA Alarm is switched.

ACT : A CPA/TCPA alarm is issued only for activated AIS targets.

ACT&Sleep : A CPA/TCPA alarm is issued for all AIS targets on the radar display.

5.4 DECISION OF TARGETS AS IDENTICAL (Association)

5.4.1 Setting of Function to Decide Targets as Identical (Association)

When an AIS target and a tracking target are decided to be identical, an association symbol is displayed for the targets regarded as identical. In this case, the AIS target symbol is automatically activated.

Attention

- Turn off **Association** in order not to make a decision on if targets are identical, or in order to display symbols that have disappeared.

Procedures

- 1) Left-click the **Association** in Target Information located at the upper right of the display.

Association will be set to on or off.

5.4.2 Setting of Conditions for Deciding AIS and Tracked Targets as Identical (Association Setting)

Procedures

- 1) Open the Association Setting menu by performing the following menu operation.

AIS

→ 1. Association Setting

The Association Setting menu will appear.

- 2) Select and enter the item to be set.

Conditions for deciding targets as identical will be set. When the differences of all item between AIS and tracked target are under the set conditions..

Once regard as identical, when one of the differences exceed 125% of the set condition, they are regarded as dissidence.



The setting for this function is common to Association Setting in the AIS Menu.

5.4.3 Types of Decision Conditions to be Set

Decision conditions	
1. Association	On / Off (Function to decide targets as identical)
2. Priority	AIS / TT (Symbol to be displayed)
3. Bearing	0.0 ~ 9.9°
4. Range	0 ~ 999m
5. Course	0 ~ 99°
6. Speed	0 ~ 99kn
7. Applicable AIS Target	ACT or ACT&Sleep (activated AIS target or all AIS target)



CAUTION



If a great value is set as a condition for deciding targets as identical, a tracking target near an AIS target is regarded as identical to the AIS target and it may not be displayed any more.

For example, when a pilot boat (which is a small target not being tracked) equipped with an AIS function approaches a cargo ship as a tracking target not equipped with an AIS function, the tracking target symbol of the cargo ship may not be displayed any more.

5.5 ALARM DISPLAY

Alarm messages for Target Tracking (TT) and AIS functions:

Error message	Description
CPA/TCPA	There is a dangerous target.
New Target	A new target is acquired in the automatic acquisition zone.
Lost	There is a lost target.
REF Target	The accuracy of the reference target may be decreased.
95% Capacity	The number of targets being tracked by the Target Tracking function has reached 95% of the maximum.
MAX Target	The number of targets being tracked by the Target Tracking function has reached the maximum.
AIS 95% Capacity	The number of displayed AIS target symbols has reached 95% of the maximum.
AIS MAX Target	The number of received data items exceeds the maximum number of AIS target symbols that can be displayed.
AIS ACT 95% Capacity	The number of activated AIS targets by the AIS function has reached 95% of the maximum.
AIS ACT MAX	The number of activated AIS targets by the AIS function has reached the maximum.
AIS Alarm ***	Alarm information issued with the ALR sentence by the AIS. *** is a 3-digit number which is Local Alarm No in the ALR sentence.
AIS Alarm 001	Tx malfunction
AIS Alarm 002	Antenna VSWR exceeds limit
AIS Alarm 003	Rx channel 1 malfunction
AIS Alarm 004	Rx channel 2 malfunction
AIS Alarm 005	Rx channel 70 malfunction
AIS Alarm 006	general failure
AIS Alarm 008	MKD connection lost
AIS Alarm 025	external EPFS lost
AIS Alarm 026	no sensor position in use
AIS Alarm 029	no valid SOG information
AIS Alarm 030	no valid COG information
AIS Alarm 032	Heading lost/invalid
AIS Alarm 035	no valid ROT information



Error message and alarm are displayed in the lower right of the display.

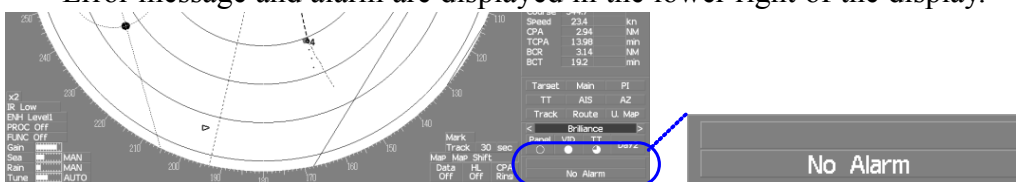

5.5.1 CPA / TCPA Alarm



CAUTION



Since these alarms may include some errors depending on the target tracking conditions, the navigation officer himself should make the final decision for ship operations such as collision avoidance.

Making the final navigation decision based only on the alarm may cause accidents such as collisions.





In the system, targets are categorized into two types: tracked / activate AIS targets and dangerous targets.

The grade of danger can easily be recognized on the display at a glance. So the officer can easily decide which target he should pay attention to.

It is not possible to switch off the tracked target visual alarm, unless tracking is ceased, or the alarm condition no longer applies.

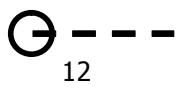
The types of target and alarm are shown below.

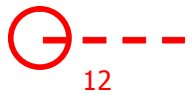
CPA / TCPA Alarm

Status	Symbol display	on	A l a r m characters	A l a r m sound	Conditions
Tracked target	 12		(Off)	(Off)	<ul style="list-style-type: none"> • CPA > CPA LIMIT • 0 > TCPA • TCPA > TCPA LIMIT The symbol is displayed when one of the above conditions is met.
Activated AIS target	 AIS12				
Dangerous target	 12 Red blinking		CPA/TCPA	Beep sound (pee-poh) Alarm acknowledge	<ul style="list-style-type: none"> • CPA ≤ CPA LIMIT • 0 ≤ TCPA ≤ TCPA LIMIT An alarm is issued when all the conditions are met. The AIS targets that issues alarm refer to 5.3.9
	 AIS12 Red blinking				

CPA Limit and TCPA Limit: The Setting Values

5.5.2 Alarm for New Target Acquired in Automatic Acquisition Zone (New Target)



CAUTION



In setting an automatic acquisition zone, it is necessary to adjust the gain, sea clutter suppression and rain / snow clutter suppression to ensure that target echoes are displayed in the optimum conditions. No automatic acquisition zone alarms will be issued for targets undetected

The automatic acquisition function sets a zone in a range and issues an alarm when a new target (which is not yet acquired) goes into this zone.

For the setting of an automatic acquisition zone, refer to "Acquiring Target" in Section 5.2.1.1 "Automatic acquisition".



Alarm for New Target Acquired in Automatic Acquisition Zone

Status	Symbol display	on	A l a r m characters	Alarm sound	Conditions
New target in automatic acquisition zone	 Red Blinking		New Target	Beep sound (pipi-pipi) Alarm acknowledge able	The alarm is issued when a new target is acquired in the automatic acquisition zone.



When an already acquired target goes into automatic acquisition zone, the alarm message is not displayed and the buzzer does not sound either.

5.5.3 Lost Target Alarm (Lost)

Attention



- **If the gain, sea clutter suppression, rain/snow clutter suppression are not adjusted adequately, the lost target alarm may be easily generated. So such adjustments should be mad carefully.**

When it is impossible to continue tracking any acquired and tracked target, or the data of AIS target cannot received for a specified time, the Lost Alarm will be generated. The typical causes for alarm generation are shown below, but not limited to the following:

- The target echo is very weak.
- The target is shadowed by a shore or a large ship and its echo is not received.
- The target echo is blurred by sea clutter returns.

If a target under tracking goes out of a range of 32 nm and can no longer be tracked, it is canceled without a lost target alarm.

Lost Target Alarm

Status	Symbol on display	Alarm characters	Alarm sound	Conditions
Lost Target	 Red Blinking	Lost	Beep sound (pee) Alarm acknowledgeable	The alarm will sound once when a lost target symbol is displayed.
	 Red Blinking			

5.5.4 Gyro Set Alarm

The GYRO I/F in this system receives signals from a gyro. Even if the power is turned off, the system will follow up the gyro. However, the system stops the follow-up operation when the power of the master gyro is turned off or when any trouble occurs to the line. When the power of the master gyro is recovered, the Set Gyro alarm will be generated.

If this alarm occurs, set the gyro.

Gyro Set Alarm

Alarm characters	Alarm sound	Conditions
Set Gyro	Beep sound (pipi-pipi)	The signals from the gyro are stopped, but the gyro is recovered.

5.6 TRACK FUNCTION

5.6.1 Past Position (Past POSN)

Procedures

- 1) **Left-click the past position display interval unit switching button in the Target Information located at the upper right of the display, and set a desired unit.**

The past position display interval unit will be set to or .

- 2) **Left-click the past position display interval switching button in the Target Information located at the upper right of the display, and set a desired track display interval.**

The past position will be set.

: Tracks are not displayed.

Numeric : Tracks are displayed at intervals of a specified value.

The past position function can display up to ten past positions of a target under tracking. The past position display interval can be set to specified time intervals of 0.5, 1, 2, or 4 minutes, or specified range intervals of 0.1, 0.2, 0.5, or 1 nm.

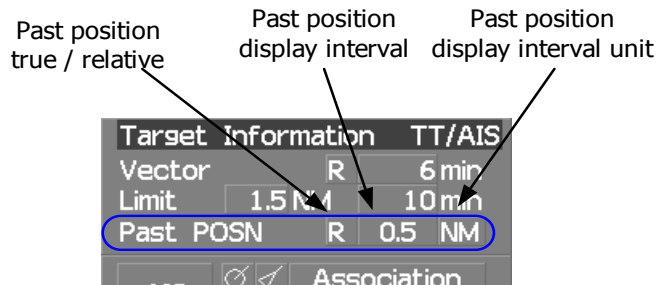

The specified interval is displayed in the past position display interval switching in Target Information located at the upper right of the display. When is displayed, the track display function is turned off.

The track mode operates in conjunction with the vector mode, and a true or relative track is displayed. In relative vector mode, the relative tracks of the target are displayed. In true vector mode, true tracks that are calculated from the relative bearing, range, own ship's course, and speed are displayed.

The target is acquisition, past position of traced target is start plot. The AIS target is displayed, past position of AIS target is start plot.

If the past position plotted time is short, the indicated past position duration may not have achieved the specified time or range.

5.6.2 Target Ship's Tracks (Target Track)

This function makes settings for the tracks of tracked targets and AIS targets.

The system can display the tracks of up to 20 target ships.

5.6.2.1 Track Color Setting (Target Track Color)

Procedures

- 1) **Put the cursor on the tracked target or activated AIS target, and right-click.**

The setting items for cursor modes will be displayed.

- 2) **Left-click** Property .

The Property will appear.

- 3) Left-click the item button of 2. Track Color .

The setting items for Track Color will be displayed.

- 4) **Left-click the button corresponding to the track color to be set.**

Colors set by performing the procedure in Section 5.6.2.3 "Setting of Target Ship's Track Colors (Target Track Color)" can be selected.

Individual colors can be set for up to 10 ships. The same color is set for 11 to 20 ships.

5.6.2.2 Target Ship's Track Function On/Off (Target Track Function)

Procedures

- 1) **Open the T.TRK menu by performing the following menu operation.**

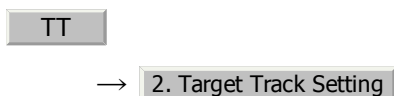

- 2) Left-click the item button of 1. Target Track Function .

The Target Track Function will be set to on or off.

On : Target Track Function is turned on.

Off : Target Track Function is turned off.



Note that when this function is turned off, all the other ship's track functions are turned off. In this case, the track data of other ships is not saved, so they cannot be traced later.

5.6.2.3 Setting of Target Ship's Track Colors (Target Track Color)

You can set either one track color for all targets under tracking, or individual colors for the ships of track numbers 1 to 10. The tracks of ships 11 to 20 are displayed in the same color.



If the other ship's track function (Target Track Function) is turned off, the track data of other ships is not saved.

Procedures

- 1) **Open the Target Track Color menu by performing the following menu operation.**

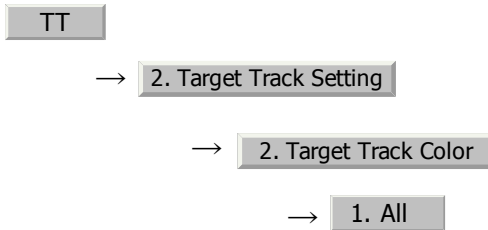

The setting items for All will be displayed.

- 2) **Left-click the button corresponding to the track display to be set.**

Individual : Track color is set individually for ships.
 color name : One color is set for all ships.

Individual setting

- 3) **Left-click the button corresponding to the track number to be set.**

The setting items for the selected track number will be displayed.

- 4) **Left-click the button corresponding to the track color to be set.**

The track color of the selected track number will be set.

When **Individual** is selected, the track numbers **Target Track No.1** to **No.10** and the individual setting for **Other** are valid. Select a color for each target.

The color list is displayed by left-clicking the button corresponding to the item number to be set. Select a desired color. There are 8 color choices: **Off**, **White**, **Gray**, **Blue**, **Green**, **Yellow**, **Pink**, and **Red**.

Target Track No.1 ~ **No.10** : Setting for 1 to 10 ships
Other : Setting for 11 to 20 ships



Note that the individual setting is not enabled unless **Individual** is selected.

5.6.2.4 Setting of Target Ship's Track Display (Target Track Display)

The target track display function can be turned on / off. Choices for track display are displaying / hiding the tracks of all ships and Individual (displaying the tracks of individual ships).

Procedures

- 1) **Open the Target Track Display menu by performing the following menu operation.**

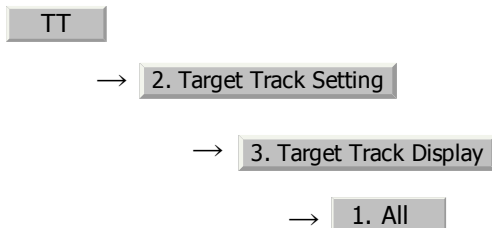

The setting items for All will be displayed.

- 2) **Left-click the button corresponding to the track display to be set.**

- : Track display is set for individual ships.
- : The tracks of all ships are hidden.
- : The tracks of all ships are displayed.



Even when Target Track Display is turned off, the track data of other ships is saved if Track Memory Interval is set.

Individual setting

- 3) **Left-click the button corresponding to the track number to be set.**

The selected track number display will be set to on or off.

- : The track number display is turned on.
- : The track number display is turned off.

When is selected, the track numbers to and the individual setting for are valid. Select on / off for each target.

- ~ : Setting for 1 to 10 ships
- : Setting for 11 to 20 ships



Note that the individual setting is not enabled unless Individual is selected.

5.6.2.5 Setting of Target Ship's Track Saving Interval (Track Memory Interval)

An interval for saving target ship's track data can be set.



This function is not available when the Target Track Function is turned off.

Procedures

- 1) **Open the Track Memory Interval menu by performing the following menu operation.**

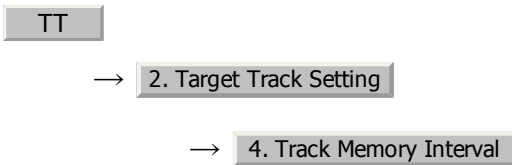

- 2) **Left-click the button corresponding to the interval to be set.**

Select an interval from the following:

- Off/
- 3sec/5sec/10sec/30sec/
- 1min/3min/5min/10min/30min/60min/
- 1NM/3NM/5NM/10NM

5.6.2.6 Clear of Target Ship's Track (Clear Track)

The target ship's track can be cleared by setting a color or a track number.



If Card T.TRK Display is used, target ship's tracks displayed through the card cannot be cleared.

[1] Clear of Tracks by Setting Color (Clear Track Color)

Procedures

- 1) **Open the Clear Track Color menu by performing the following menu operation.**

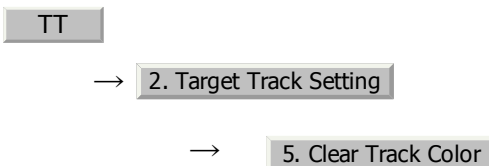

The setting items for Clear Track Color will be displayed.

- 2) **Left-click the button corresponding to the color of the target tracks to be cleared.**

The Confirmation Window will appear.

- 3) Left-click **1. Yes** to clear the track line.

All the tracks of the selected color will be cleared.

[2] Clear of Tracks by Setting Track Number (Clear Track Number)

Procedures

- 1) **Open the T.TRK menu by performing the following menu operation.**

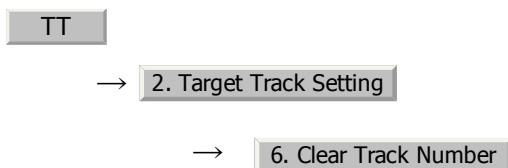

The setting items for Clear Track Number will be displayed.

- 2) **Left-click the button corresponding to the number of the tracks to be cleared.**

The Confirmation Window will appear.

- 3) **Left-click 1. Yes to clear the track line.**

The tracks of the selected number will be cleared.

5.6.2.7 Operation of Target Ship's Track Data Saved on Card (File Operations)

Target ship's track data can be saved on a flash memory card and read from the card.



Data can be saved to a flash memory card until the card becomes full, but the number of files that can be read and displayed is limited to 64 in alphanumeric order. When the number of files has reached 64, delete unnecessary files.

[1] Loading File (Load)

Procedures

- 1) **Insert a flash memory card into the card slot**

Flash memory card (option) is necessary.

- 2) **Open the File Operations menu by performing the following menu operation.**

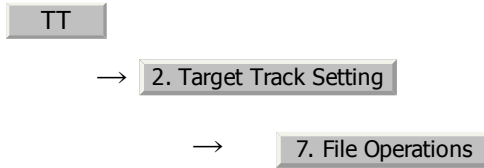

- 3) Left-click the item button of to select a card slot.

The setting item for Select Card Slot is switched between Slot1 and Slot2.

- 4) **Left-click the item button of to select Add or Overwrite.**

The setting item for Load Mode is switched between and .

When is selected, new data is added to the current data on the card. When is selected, new data is saved over the current data on the card.

- 5) **Left-click .**

Currently saved target ship's track data will be listed.

- 6) **Left-click the button corresponding to the file to be loaded.**

The Confirmation Window will appear.

- 7) **Left-click to load the file.**

The selected target track data will be loaded and shown on the radar display.

[2] Saving File (Save)

Procedures

- 1) **Insert a flash memory card into the card slot.**

Flash memory card (option) is necessary.

- 2) **Open the File Operations menu by performing the following menu operation.**

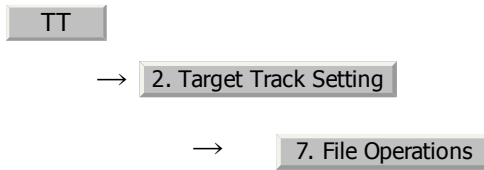

- 3) **Left-click the item button of 1. Select Card Slot to select a card slot.**

The setting item for Select Card Slot is switched between Slot1 and Slot2.

- 4) **Left-click 4. Save .**

The Input File Name menu will appear.

- 5) **Input the file name to be saved.**

Up to ten characters can be input as a file name.

For inputs to the characters input screen, refer to Section 3.3.4.7 "Entering a character". After the input, the Confirmation Window will appear.

- 6) **Left-click 1. Yes to save the file.**

The currently displayed target track data will be saved.

[3] Erasing File (Erase)**Procedures**

- 1) **Insert the flash memory card into the card slot.**

Flash memory card (option) is necessary.

- 2) **Open the File Operations menu by performing the following menu operation.**

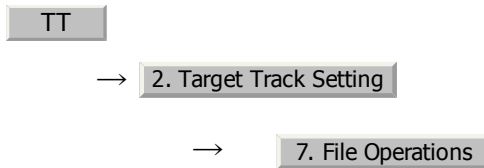

- 3) **Left-click the item button of 1. Select Card Slot to select a card slot.**

The setting item for Select Card Slot is switched between Slot1 and Slot2.

- 4) **Left-click 5. Erase.**

The Erase menu will appear.

Currently saved target ship's track data on the card will be listed.

- 5) **Left-click the button corresponding to the file to be erased.**

The Confirmation Window will appear.

- 6) **Left-click 1. Yes to erase the file.**

The selected target track data will be erased and the file name will disappear from the list.

[4] Displaying File (Card Target Track Display)

Procedures

- 1) **Insert the flash memory card into the card slot.**

Flash memory card (option) is necessary.

- 2) **Open the File Operations menu by performing the following menu operation.**

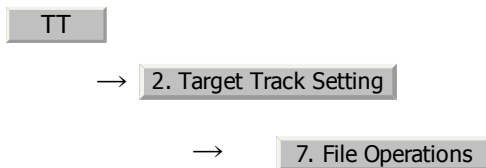

- 3) **Left-click the item button of 1. Select Card Slot to select a card slot.**

The setting item for Select Card Slot is switched between Slot1 and Slot2.

- 4) **Left-click 6. Card T.TRK Display .**

The Card T.TRK Display menu will appear.

Currently saved target ship's track data on the card will be listed.

- 5) **Left-click the button corresponding to the file to be displayed.**

The Confirmation Window will appear.

- 6) **Left-click 1. Yes to display the T.TRK line.**

The selected file will be highlighted, and the currently saved target track data will be displayed.

Cancel

- 1) **Open the Card T.TRK Display window.**

The displayed file is highlighted.

- 2) **Left-click the button corresponding to the displayed file.**

The file will be deselected and returned to normal display.

5.7

TRIAL MANEUVERING (Trial Maneuver)

Attention

- **Trial maneuvering is to simulate own ship's course and speed in the conditions that the course and speed of a target ship are unchanged as they are. As the situation is different from any actual ship maneuvering, set values with large margins to CPA Limit and TCPA Limit.**

5

The trial maneuvering is the function of simulating own ship's course and speed for collision avoidance when a dangerous target appears. When the own ship's course and speed are entered in manual mode, the trial maneuvering function checks if pre-acquired or pre-activated targets are dangerous.

The ranges of course and speed to be entered manually:

Course: 360° (in 0.1° intervals) [EBL] dial

Speed: 0 to 100kn (in 0.1kn step) [VRM] dial

5.7.1 Trial Maneuvering in the True Vector Mode

In the True Vector mode, calculations are performed according to the values set by Trial Speed, Trial Course and other features, and the result is displayed as a bold-line that represents the change of own ship's vector as shown in the Fig 5-7 below (an example of the course changed to the right).

In this Fig 5-7, the dangerous target forward left becomes safe as a result of simulation.

The tracked target information indicates the current CPA and TCPA values regardless of the result of simulation.

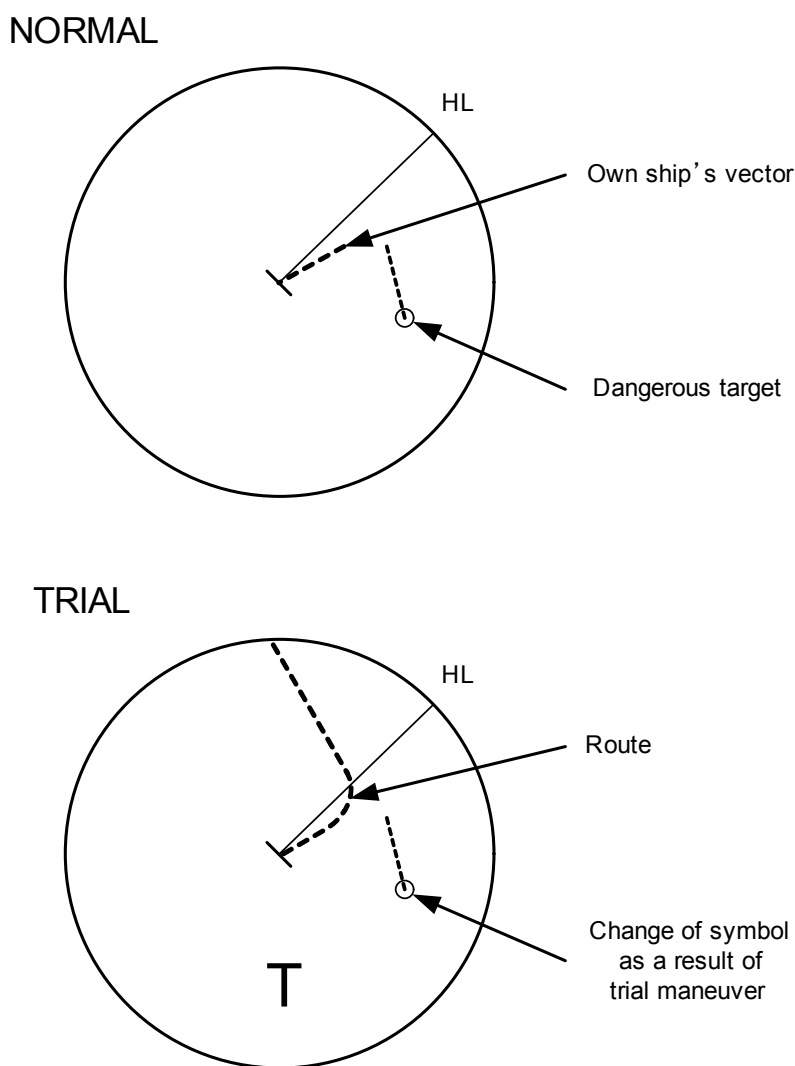
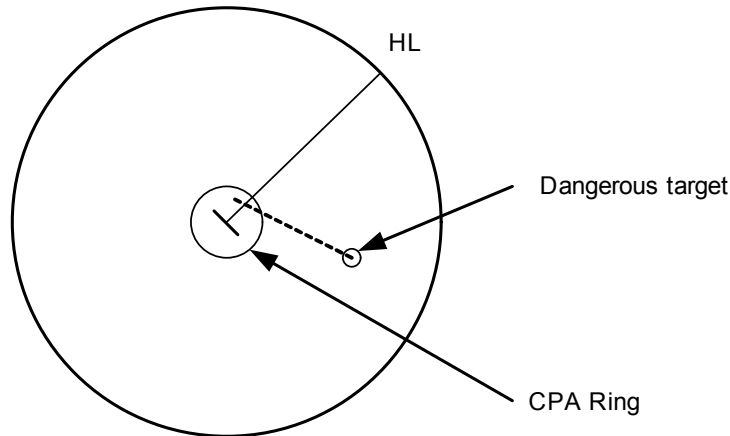

Fig 5-7: True Vector Mode

5.7.2 Trial Maneuvering in the Relative Vector Mode

The result of Trial maneuvering in the Relative Vector mode is shown by a change in target vector. In the Fig 5-8 below (in the same conditions as in the True Vector mode in the previous page), it is seen that the acquired target is a dangerous one because its vector is crossing the CPA RING.

NORMAL



TRIAL

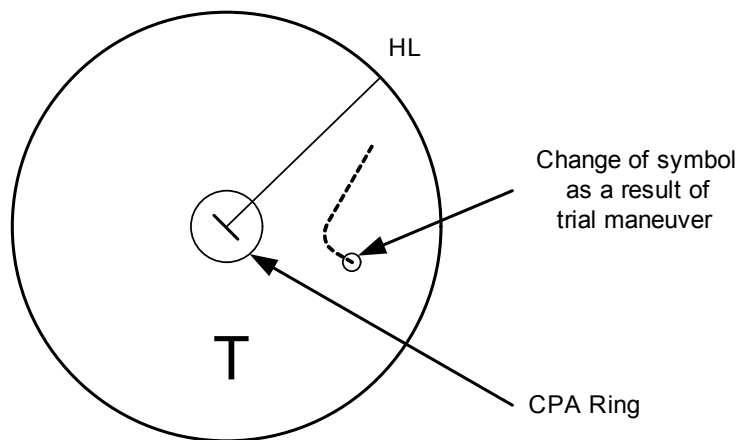

Fig 5-8: *Relative Vector Mode*

The above Fig 5-8 shows that the relative vector of the target has changed as shown in the figure as a result of simulation (course and speed), so that the symbol color is changed into “White”, a safe target.

Irrespective of the simulation results, the current CPA and TCPA values are shown in the tracked target information just like when the true vector mode is active.

The course change of own ship is displayed as a dotted-line.

Better information is provided by using relative motion and sea stabilization.

5.7.3 Operation of Trial Maneuvering Function

Procedures

- 1) **Open the Trial Maneuver menu by performing the following menu operation.**



- 2) **Left-click the item button of 1. Trial Function .**

The Trial Function will be set to on or off.

On : The trial maneuvering function is turned on.

Off : The trial maneuvering function is turned off.

When Trial Function is set to on, the character " T " indicating trial maneuvering blinks in the own ship display field of the radar display.

- 3) **Set values for Course by turning the [EBL] dial, and for Speed by turning the [VRM] dial.**

- 4) **Set other characteristics.**

Vector Time : Vector time (1 to 60 min)

Time to Maneuver : Time until trial maneuvering is started (0 to 30 min)

Own Ship Dynamic Trait : Dynamic trait of the own ship

→ **Reach** : Range from when steered to when the ship begins to turn (0 to 2000 m)

→ **Turn Radius** : Turning radius (0.10 to 2.00 nm)

→ **Acceleration** : Acceleration (0.0 to 100 knots/min)

→ **Deceleration** : Deceleration (0.0 to 100 knots/min)

For inputs to the value input screen, refer to Section 3.3.4.2 "Directly entering a numeric value".

Dangerous target symbols are displayed in red and safe target symbols in white.

 Vector Time is valid only when Trial Function is set to on. If it is off, the vector time before trial maneuvering is displayed.

Time until the start of trial maneuvering is counted down immediately after the input. The acceleration and deceleration are influenced depending on the relationship between the current speed and the input speed for trial maneuvering.

If 0.0 kn/min is set for Acceleration when the speed for trial maneuvering is faster than the current speed, or for Deceleration when the speed for trial maneuvering is slower than the current speed, the system performs simulation on the assumption that the speed is changed immediately after the time set for Time to Maneuver .

Cancel

- 1) **Open the Trial Maneuver menu by performing the following menu operation.**



- 2) **Left-click the item button of 1. Trial Function .**

The Trial Function will be set to on or off.

Off : The Trial Function will be set to off.

SECTION 6

TRUE AND FALSE ECHOES ON DISPLAY

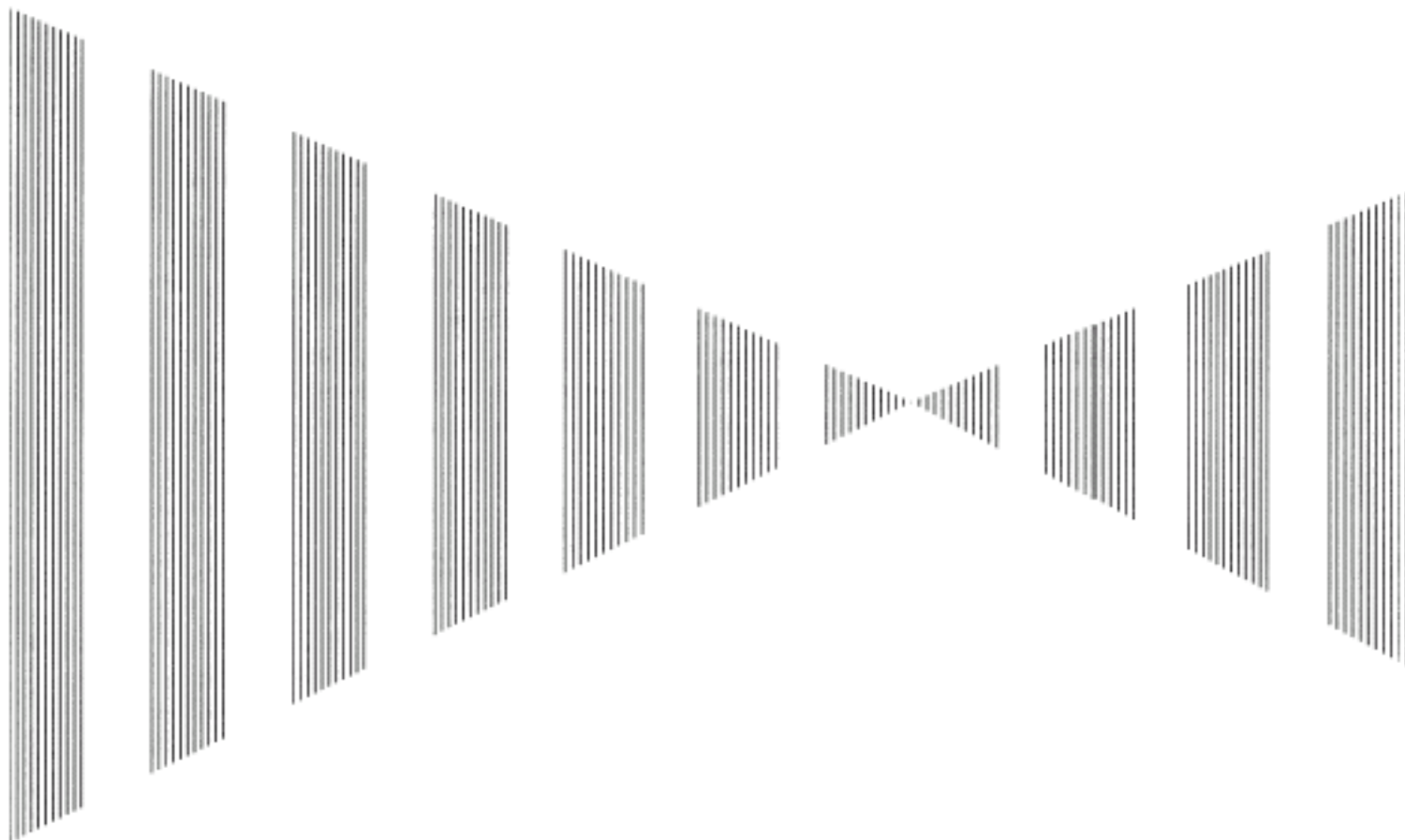

TRUE AND FALSE ECHOES ON DISPLAY

6.1	RADAR WAVE WITH THE HORIZON	6-1
6.2	STRENGTH OF REFLECTION FROM THE TARGET	6-3
6.3	SEA CLUTTER AND RAIN AND SNOW CLUTTER	6-5
6.4	FALSE ECHOES	6-9
6.5	DISPLAY OF RADAR TRANSPONDER (SART)	6-12

The radar operator has a role of interpreting the radar displays to provide his best aid in maneuvering the ship. For this purpose, the operator has to observe the radar displays after fully understanding the advantages and disadvantages that the radar has. For better interpretation of radar display, it is important to gain more experiences by operating the radar equipment in fair weathers and comparing the target ships watched with the naked eyes and their echoes on the radar display.

The radar is mainly used to monitor the courses of own ship and other ships in open seas, to check buoys and other nautical marks when entering a port, to measure own ship's position in the coastal waters relative to the bearings and ranges of the shore or islands using a chart, and to monitor the position and movement of a heavy rain if it appears on the radar display.

Various types of radar display will be explained below.

6.1 RADAR WAVE WITH THE HORIZON

Radar beam radiation has the nature of propagating nearly along the curved surface of the earth. The propagation varies with the property of the air layer through which the radar beam propagates. In the normal propagation, the distance (D) of the radar wave to the horizon is approximately 10% longer than the distance to the optical horizon. The distance (D) is given by the following formula:

$$D = 2.23(\sqrt{h_1} + \sqrt{h_2}) \text{ [NM]}$$

h_1 : Height (m) of radar scanner above sea level

h_2 : Height (m) of a target above sea level

Fig 6-2 is a diagram for determining the maximum detection range of a target that is limited by the curve of the earth surface in the normal propagation.

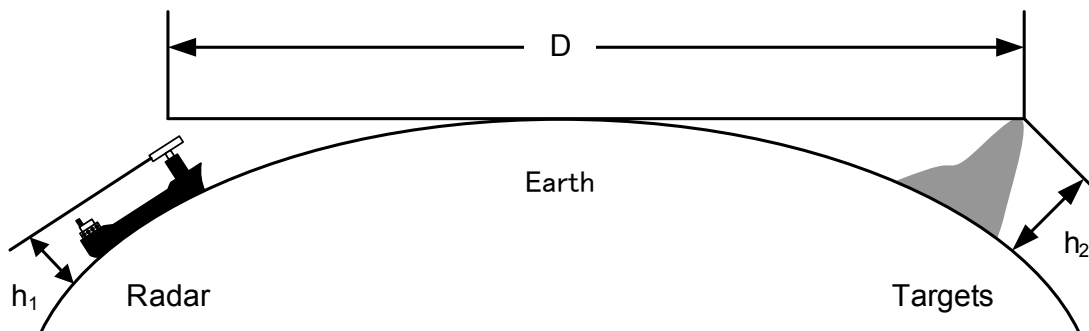

Fig 6-1: RADAR wave with the horizon

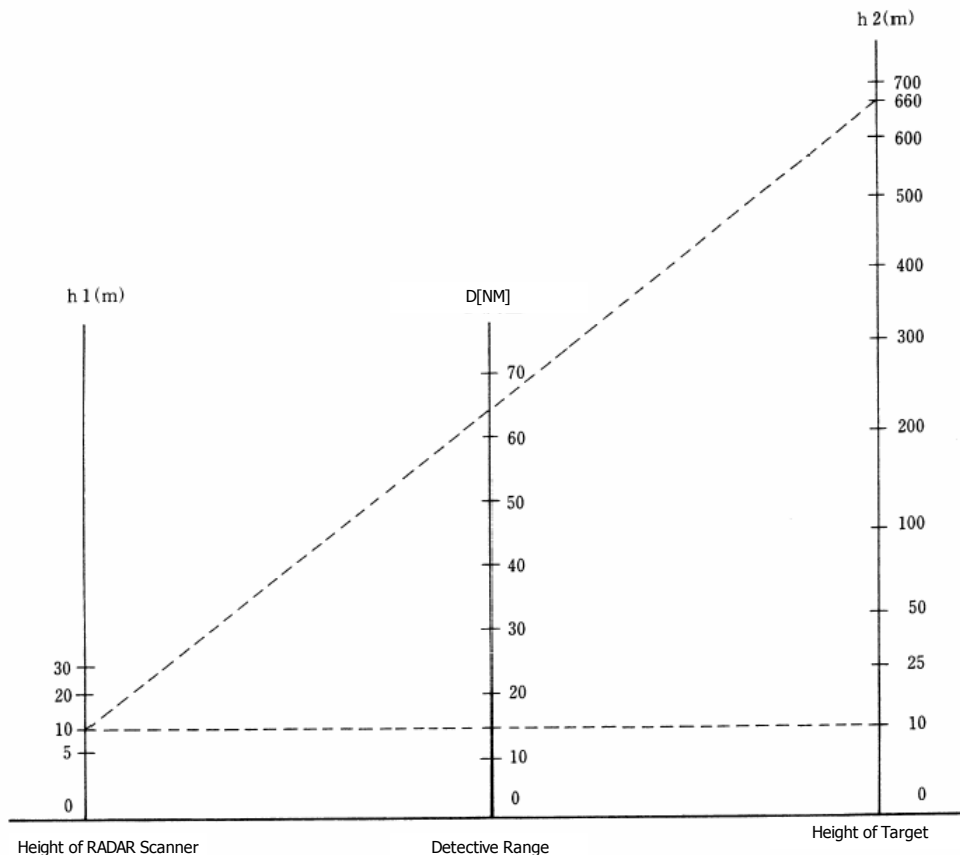

Fig 6-2: Maximum detection range of a target

When the height of own ship's scanner is 10 m for instance,

- i. A target that can be detected at the radar range of 64 nm on the radar display is required to have a height of 660 m or more.
- ii. If the height of a target is 10 m, the radar range has to be approx. 15 nm. However, the maximum radar range at which a target can be detected on the radar display depends upon the size of the target and the weather conditions, that is, the radar range may increase or decrease depending upon those conditions.

6.2

STRENGTH OF REFLECTION FROM THE TARGET

The signal intensity reflected from a target depends not only on the height and size of the target but also on its material and shape. The echo intensity from a higher and larger target is not always higher in general.

In particular, the echo from a coast line is affected by the geographic conditions of the coast. If the coast has a very gentle slope, the echo from a mountain of the inland appears on the radar display.(Fig 6-3) Therefore, the distance to the coast line should be measured carefully.

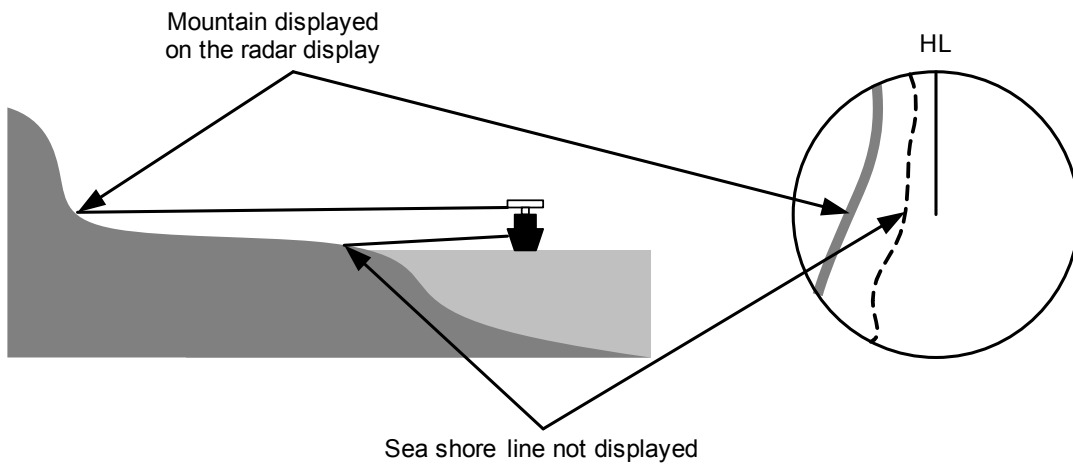

Fig 6-3: Sea shore line which is not displayed

Table 6-1 shows the graph indicating the relation between the target detection distance and the radar reflection cross-sectional area (RCS) with regard to the type and the height of the target in a situation in which the weather is good, the sea state is calm and the radio wave propagation is normal. As revealed by this table, even on the same sea shore line, detection distance greatly differs depending on the height of the target from the surface of the sea. Furthermore, because the target detection distance is greatly influenced by the shape and material of the target and environmental conditions, such as the sea state, weather, and radio wave propagation, caution should be taken when detecting distance of target.

Table 6-1 : Relation between type and height of target and detection distance and RCS

Type of target	Height from sea surface (m)	Detection distance (NM)		RCS [m_2]	
		X band	S band	X band	S band
Sea shore line	60	20	20	50,000	50,000
Sea shore line	6	8	8	5000	5000
Sea shore line	3	6	6	2500	2500
SOLAS target ship (>5000GT)	10	11	11	50,000	30,000
SOLAS target ship (>500GT)	5	8	8	1800	1000
Small boat with IMO standard compatible radar reflector	4	5.0	3.7	7,5	0,5
Marine buoy with corner reflector	3,5	4.9	3.6	10	1
Standard marine buoy	3,5	4.6	3.0	5	0,5
10-meter small boat without radar reflector	2	3.4	3.0	2,5	1,4
Waterway location beacon	1	2.0	1.0	1	0,1



Detection distance shown in the above table may greatly decrease depending on the shape of the target, sea state, weather and radio wave propagation conditions.

6.3

SEA CLUTTER AND RAIN AND SNOW CLUTTER

In addition to the echo required for observing ships and land, radar video image also includes unnecessary echo, such as reflection from waves on the sea surface and reflection from rain and snow. Reflection from the sea surface is called "sea clutter," and reflection from rain and snow is called "rain and snow clutter," and those spurious waves must be eliminated by the clutter rejection function.

a. Sea clutter

Sea clutter appears as an image radiating outwardly from the center of the radar display and changing depending on the size and the shape of waves. Generally, as waves become larger, image level of the sea clutter is intensified and the clutter far away is also displayed. When waves are large and the sea clutter level is high, it is difficult to distinguish sea clutter from a small boat whose reflection intensity is weak. Accordingly, it is necessary to properly adjust the sea clutter rejection function. Table 6-2 shows the relation between the sea state (SS) showing the size of waves generated by wind and the radar's detection probability.

Table 6-2 : Sea state and probability of target detection

S band radar (probability to detect a target at a distance of 0.4 NM)				
RCS	SS1 ~ 2	SS2 ~ 3	SS3 ~ 4	SS4 ~ 5
0.1m2	V ⁱ	V-M ⁱⁱ	M-NV ⁱⁱⁱ	
0.5 m2	V	V	V-M	M-NV
1 m2	V	V	V	V-M

X band radar (probability to detect a target at a distance of 0.7 NM)				
RCS	SS1 ~ 2	SS2 ~ 3	SS3 ~ 4	SS4 ~ 5
1m2	V-M	M-NV		
5 m2	V	V-M	M-NV	
10 m2	V	V	V	V-M

i. V: Detection probability of 80 %

ii. M: Detection probability of 50 %

iii. NV: Detection probability of less than 50 %

As shown in Table 6-2, the number of SS increases as the wind speed becomes high and the waves become large. Table 6.2 reveals that detection probability decreases from V (80 %) to NV (less than 50 %) as the number of SS increases. Therefore, even if the sea state is calm and a target clearly appears on the radar display, when the sea state becomes rough, target detection probability decreases resulting in difficulty of target detection by the radar.

Table 6-3 : Relation between Douglas sea state and average wind speed and significant wave height

Sea state	Average wind speed (kn)	Significant wave height (m) ⁱ
0	<4	<0,2
1	5-7	0,6
2	7-11	0,9
3	12-16	1,2
4	17-19	2,0
5	20-25	3,0
6	26-33	4,0

i. Significant wave height: an average of top N/3 higher waves when the number of waves detected within a constant time duration is N

For example, in the case of a standard marine buoy, RCS of X band radar is 5 m² as shown in Table 6-1. When observing such a target in the sea state (SS3) in which significant wave height exceeds 1.2 meters, detection probability is M-NV, as shown in Table 6-2, which indicates 50 % or less.

b. Rain and snow clutter

Rain and snow clutter is a video image that appears in a location where rain or snow is falling. The image changes according to the amount of rain (or the amount of snowfall). As precipitation increases, the image of rain and snow clutter becomes intensified on the radar display, and in the case of localized heavy rain, an image similar to the image indicating land is displayed in some cases. Furthermore, because radio waves tend to attenuate due to rain and snow, the ability to detect a target in the rain and snow clutter or a target beyond the rain and snow clutter may decrease. The amount of attenuation depends on the transmission frequency, antenna beam width, and the pulse length. Fig 6-4 and Fig 6-5 show examples in which detection distance is reduced due to the influence of precipitation. Because of this, a target, which clearly appeared up to 10 NM by an X band radar (pulse width of 0.8μs) when it was not raining, may become dimly visible up to 5 NM when the amount of rain becomes 4 millimeters per hour. Furthermore, when comparing the X band radar with the S band radar, target detection distance decreases less when an S band radar is used, which means it is influenced less by precipitation.

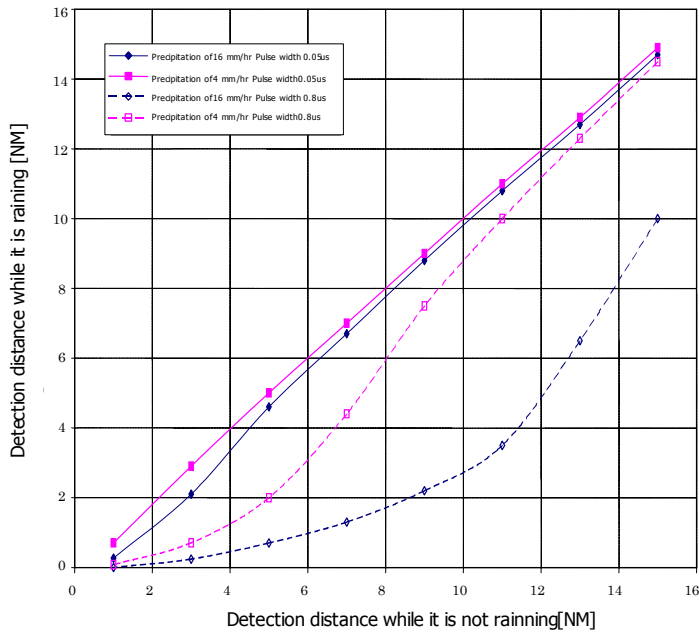

Fig 6-4: Decreased target detection distance by S band radar due to precipitation

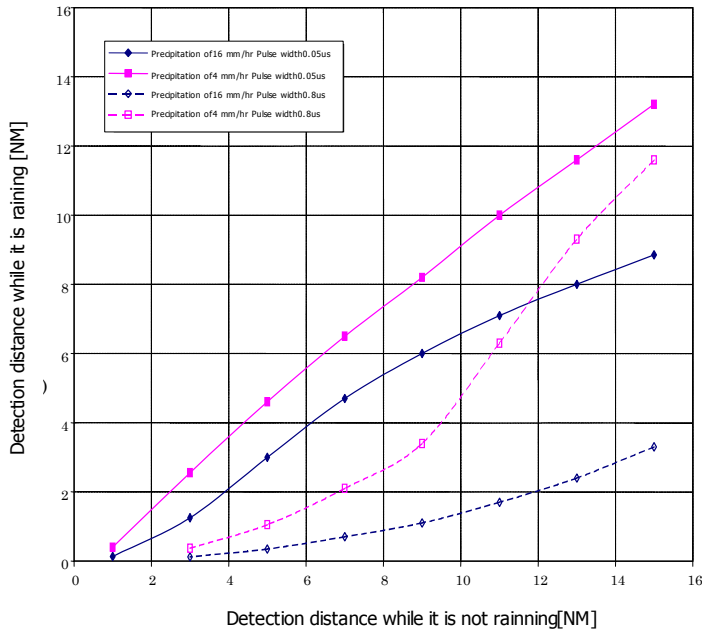

Fig 6-5: Decreased target detection distance by X band radar due to precipitation

6

c. Coping with sea clutter and rain and snow clutter

When the weather is bad and the ocean is rough, the use of an S band radar is effective because the radar is not influenced by sea clutter so much and attenuation due to rain drops is small. When an X band radar is used, reducing the pulse width will reduce the influence by spurious waves, and also the spurious wave rejection function effectively works; therefore, the use of short pulse is effective when the weather is bad. By using image processing functions PROC1 1 to 3, it is expected that spurious waves are further suppressed. Since optimal settings for those items can be automatically made by using the function mode, it is recommended that STORM or RAIN be used by selecting the function mode when the weather is bad. For details of the function mode, see Section 3.9 "USE FUNCTION KEY [USER]".

However, these functions may make some targets invisible, particularly targets with higher speeds.

6.4 FALSE ECHOES

The radar observer may be embarrassed with some echoes that do not exist actually. These false echoes appear by the following causes that are well known:

a. Shadow

When the radar scanner is installed near a funnel or mast, the echo of a target that exists in the direction of the funnel or mast cannot appear on the radar display because the radar beam is reflected on the funnel or mast. Whether there are some false echoes due to shadows can be checked monitoring the sea clutter returns, in which there may be a part of weak or no returns.

Such shadows appear always in the same directions, which the operator should have in mind in radar operation.

b. Side Lobe Effect

A broken-line circular arc may appear at the same range as the main lobe of the radar beam on the radar display. This type of false echo can easily be discriminated when a target echo appears isolated. (see Fig 6-6)

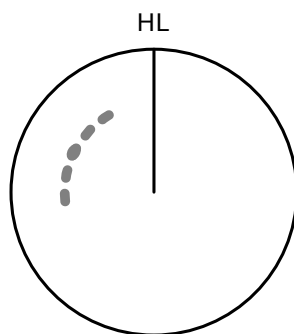

Fig 6-6: *False echo*

c. False Echo by Secondary Reflection

When a target exists near own ship, two echoes from the single target may appear on the radar display.

One of those echoes is the direct echo return from the target and the other is the secondary reflection return from a mast or funnel that stands in the same direction as shown in Fig 6-7.

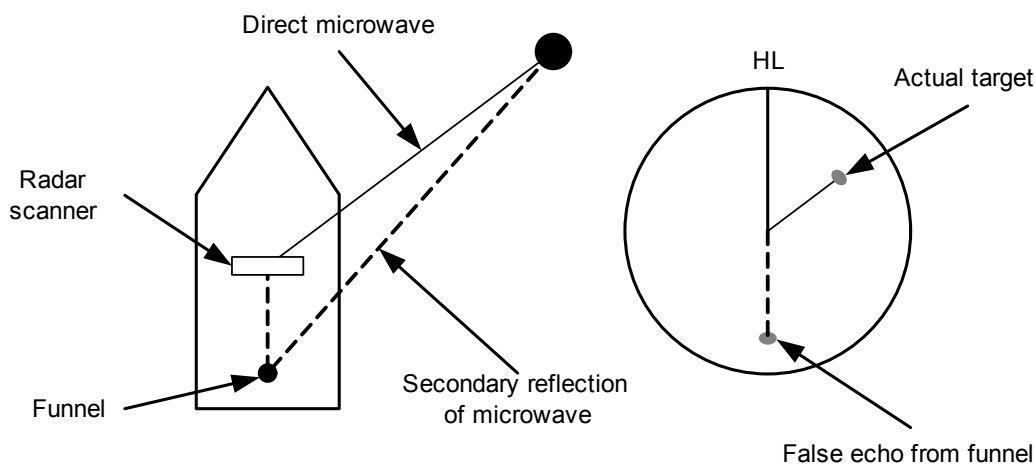

Fig 6-7: False echo by secondary reflection

d. False Echo by Multiple Reflection

When there is a large structure or ship with a high vertical surface near own ship as shown in Fig 6-8, multiple reflection returns may appear on the radar display. These echoes appear in the same intervals, of which the nearest echo is the true echo of the target.

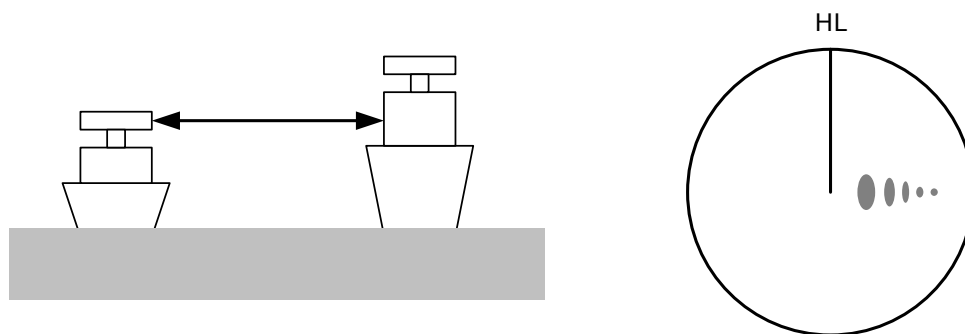

Fig 6-8: False echo by mutiple reflection

e. Second Time Echoes

The maximum radar detection range depends upon the height of the scanner and the height of a target as described in the Section 6.1 "RADAR WAVE WITH THE HORIZON". If a so-called "duct" occurs on the sea surface due to a certain weather condition, however, the radar beam may propagate to a abnormally long distance, at which a target may be detected by the radar.

For instance, assuming that the pulse length is MP3 (on the repetition frequency of 1400 Hz), the first pulse is reflected from a target at about 58 NM or more and received during the next pulse repetition time. In this case, a false echo (second time echo) appears at a position that is about 58 NM shorter than the actual distance. If the false echo appears at 5 NM on the radar display, the true distance of the target is $5+58=63$ NM. On the pulse length is SP1 (on the repetition frequency of 2250 Hz), a false echo may appear at a position that is about 36 NM shorter than the actual distance.

This type of false echo can be discriminated by changing over the range scale (the repetition frequency), because the distance of the target changes accordingly.

If second time echo is appeared, the use of Economy mode in PRF menu is effective. Otherwise, Stagger Trigger menu set to on. (See Section 3.8.3 "Set Scanner Unit (TXRX Setting)").

f. Radar Interference

When another radar equipment using the same frequency band as that on own ship is near own ship, a radar interference pattern may appear on the radar display. This interference pattern consists of a number of spots which appear in various forms. In many cases, these spots do not always appear at the same places, so that they can be discriminated from the target echoes. (See Fig 6-9)

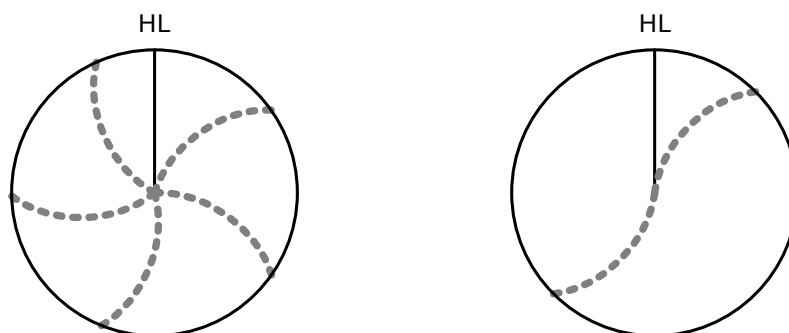

Fig 6-9: Radar interference

If radar equipment causing an interference pattern and this radar are of the same model, their transmitting repetition frequency is nearly the same. As a result, interference patterns may be displayed concentrically.

In this case, the interference patterns cannot be eliminated by using only the interference reflector function, so in-tune the transmitting repetition frequency. (See Section 3.8.3 "Set Scanner Unit (TXRX Setting)")

An interference suppressing effect can be heightened by applying a different transmitting repetition frequency to the interference pattern source radar and this radar.

6.5

DISPLAY OF RADAR TRANSPONDER (SART)

The SART (Search and rescue Radar Transponder) is a survival device authorized by the GMDSS (Global Maritime Distress and Safety System), which is used for locating survivors in case that a distress accident occurs at sea. The SART is designed to operate in the 9 GHz frequency band.

When receiving the 9 GHz radar signal (interrogating signal) transmitted from the radar equipment on a rescue ship or search aircraft, the SART transmit a series of response signals to inform the distress position to the rescue and search party.



This radar provides a shortcut item to make settings for SART signal reception. Execution of this item automatically switches to the setting for SART reception. It also functions for detect the beacon or target enhancer.

Procedures

- 1) Press [RANGE +] or [RANGE -] key to set the radar range to 6 NM or 12 NM.
- 2) Set the SART display mode according to the procedures below.

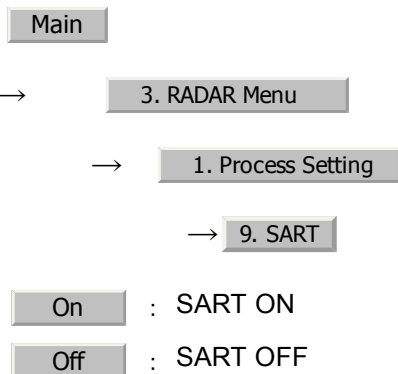

With the SART display mode set to ON, settings as shown below are made automatically.

- Sea clutter control : Minimum (Most counterclockwise)
- AUTO SEA function : OFF
- Rain and Snow Clutter Control (RAIN) : Minimum
- Auto Rain and Snow Clutter function : OFF
(AUTO RAIN)
- TUNE control : No tuning (to weaken clutter echoes)
- Interference rejection (IR) : OFF
- PROCESS : OFF

[Example of Display]

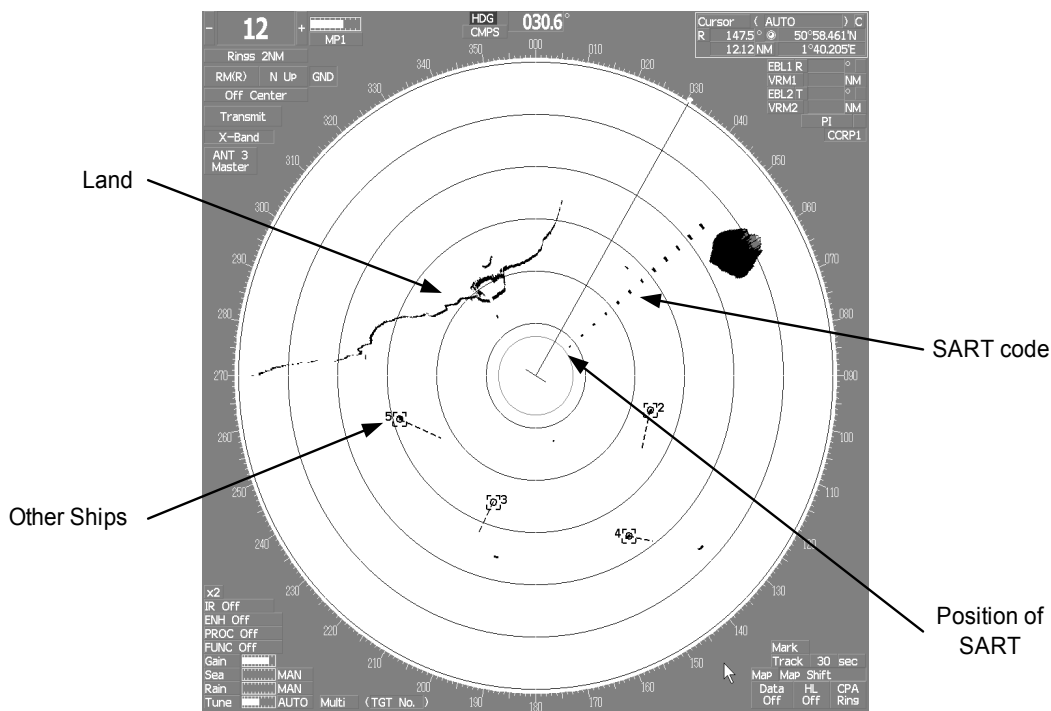

Attention

- **When the SART function is set to ON, small targets around own ship will disappear from the radar display. So it is necessary to exercise full surveillance over the conditions around own ship by visual watch in order to avoid any collision or stranding.**

If two or more sets of radar equipment are installed on own ship, use one set of 9 GHz band radar for detection of the SART signal and operate others as normal radars for avoiding collision, monitoring targets around own ship, and checking on own ship's position and avoidance of stranding.

After end of detecting the SART signal, turn the SART display off. Then the radar returns normally to the nautical mode.



SECTION 7

SETTINGS FOR SYSTEM OPERATION

SETTINGS FOR SYSTEM OPERATION

7.1	SETTINGS AT INSTALLATION	7-1
7.1.1	How to Open the Serviceman Menu (Service Man Menu)	7-1
7.1.2	GYRO I/F Setting	7-2
7.1.3	Tuning (Tune Adjustment)	7-5
7.1.4	Bearing Adjustment	7-7
7.1.5	Range Adjustment	7-7
7.1.6	Navigator Setting (Device)	7-8
7.1.7	Setting of True Bearing Value	7-9
7.1.8	Antenna Height Setting (Antenna Height)	7-9
7.1.9	Setting of CCRP (CCRP Setting)	7-10
7.2	SETTINGS	7-12
7.2.1	Communication Port Setting (COM Port Setting)	7-12
7.2.2	Sector Blank Setting (Sector Blank)	7-16
7.2.3	TNI Blank Setting (TNI Blank)	7-17
7.2.4	Setting of Bearing Pulses from Scanner Unit (Output Pulse) ...	7-18
7.2.5	Slave Mode Setting (Master/Slave)	7-19
7.2.6	Language Setting (Language)	7-20

7.2.7	Date Time Setting	7-20
7.2.8	Input Installation Information	7-21
7.2.9	Setting the Alarm System	7-22
7.3	ADJUSTMENT	7-26
7.3.1	Noise Level Adjustment (Noise Level)	7-26
7.3.2	Adjustment of Target Tracking Function (TT)	7-27
7.3.3	Main Bang Suppression Level Adjustment (MBS)	7-29
7.3.4	Adjustment of Performance Monitor	7-31
7.4	MAINTENANCE MENU	7-33
7.4.1	Antenna Safety Switch (Safety Switch)	7-33
7.4.2	Initialization of Memory Area(Area Initial)	7-34
7.4.3	Save of Internal Memory Data (Card1/2)	7-35
7.4.4	Restoration of Scanner Unit Operation Time (TXRX Time)	7-36
7.4.5	Update of Character String Data (String Data Update)	7-38

7.1 SETTINGS AT INSTALLATION

This section describes the electrical adjustment procedures to be performed by service engineers during system installation.

The bearing adjustment value is saved to non-volatile memory in the scanner. Other settings are saved to non-volatile memory in the radar process unit.



CAUTION



- Do not carry out the adjustments of the equipment except authorized service persons. If wrong setting is carried out, this may cause unstable operation.
- Do not carry out the adjustments during navigation. Otherwise, the radar performance may be affected, resulting in an accident or trouble.

7.1.1 How to Open the Serviceman Menu (Service Man Menu)

Procedures

- 1) Hold down the **Main** button at the lower right of the display together with the left key.

The Code Input menu will appear.

- 2) Left-click the **0** button.
- 3) Left-click the **ENT** button.

The Serviceman Menu will appear.



Fig 7-1: Code Input

7.1.2 GYRO I/F Setting

a. Gyro Settings (STEP or SYNC)

The GYRO I/F circuit of the system is designed to be compatible with most types of gyro compasses by simply setting the switches.

Step motor type: DC24V to DC100V

Synchro-motor type: Primary excitation voltage 50 to 115 VAC

Before power-on operation can be performed, the switches S1, S2, S5, S6, S7 and jumper TB105 on the gyro interface circuit (PC4201) must be set in accordance with the type of your gyro compass by performing the procedure below.

The switches are factory-set for a gyration ratio of 180X and the step motor type. Make sure of the type of the gyro compass installed on the own ship before starting the procedure below.

Procedures

1) **Set S5 to "OFF".**

The gyro compass and GYRO I/F are broken off.

2) **Set S6 and S7 in accordance with the type of your gyro compass.**

There are two types of gyro compasses: one type outputs a step signal, and the other type outputs a synchro signal. Make sure of the type of the gyro compass installed on the own ship before setting the switches S6 and S7.

Synchro signal: Set the switches to [SYNC].

Step signal: Set the switches to [STEP].

3) **Set the DIP switch S1 in accordance with the type of the compass.**

The items to be set are listed below. For the settings, refer to Table 7-1: Gyro and Log Select Switches (S1 DIP Switch).

S1-1: Type of gyro signal (step/synchro)

S1-2/3: Gyration ratio of gyro compass

S1-4: Gyration direction of gyro compass

S1-5: Type of log signal (pulse/synchro)

S1-7/8: Ratio of log signal

4) **Set the DIP switch S2.**

The items to be set are listed below. For the setting, refer to Table 7-2: Gyro and Log Select Switches (S2 DIP Switch).

1	2	3	4	5	6	7	8
ON	OFF	OFF	OFF	ON	OFF	ON	OFF

5) **Confirm the settings of the DIP switch S10.**

The DIP switch must be set as shown below. Do not change any of the settings.

1	2	3	4	5	6	7	8
OFF	OFF	OFF	OFF	OFF	OFF	OFF	OFF

6) **Set the jumper TB105.**

The TB105 is set for using a low-voltage step signal.

1-2 connected: Setting for normal use

2-3 connected: Setting for a step signal of 22 V or less

7) **Connect the gyro signal and log signal cables to the terminal block.**

8) **Set S5 to "ON".**

The gyro compass and GYRO I/F are connected.

9) **After power-on operation, make sure of the radar video and the operation with the true bearing value.**

See the Section 7.1.7 "Setting of True Bearing Value".

10) **If the true bearing value of the radar equipment is reversed, change the setting of the switch S1-4.**

Table 7-1 : Gyro and Log Select Switches (S1 DIP Switch)

		1	2	3	4	5	6	7	8	
GYRO SIG	STEP	ON								
	SYNC	OFF								
	360X			OFF	OFF					
	180X			ON	OFF					
	90X			OFF	ON					
	36X			ON	ON					
	DIRECTION			REV		ON				
			NOR		OFF					
LOG SIG	TYPE	SYNC				ON				
		PULSE				OFF				
	PULSE / NM	Don't care						OFF		
		100P / 30X							ON	ON
		200P / 90X							OFF	ON
		400P / 180X							ON	OFF
		800P / 360X							OFF	OFF

Table 7-2 : Gyro and Log Select Switches (S2 DIP Switch)

S2 SETTING TABLE		1	2	3	4	5	6	7	8
OTHER SETTING	LOG ALARM	ON							
		OFF							
	GYRO SIMULATOR	ON							
		OFF							
	LOG SIMULATOR	ON							
		OFF							
	N.A.	Don't care			any				
	GYRO ALARM TIME	5s				ON			
		0.2s				OFF			
	HEADING SENSOR SOURCE	NMEA(HDT/THS)			ON				
		GYRO SIGNAL			OFF				
	NMEA BAUDRATE SETTING	4800				OFF	OFF		
		9600				ON	OFF		
		19200				OFF	ON		
38400				ON	ON				

7.1.3 Tuning (Tune Adjustment)

Adjust the tuning control for the transmitter and receiver.

The turning control should be adjusted when the system is installed or when the magnetron is replaced.

Procedures

- 1) **Set a range of 48 NM or more.**
- 2) **Open the Serviceman Menu.**
- 3) **Perform the following menu open procedure to open the Tune Adjustment menu.**

1. Adjust Menu

→

1. Tune Adjustment

- 4) **Adjust the tune adjustment value so that the tune indicator bar at the upper left of the display is maximized.**

For inputs to the value input screen, refer to Section 3.3.4.3 "Increasing or decreasing a numeric value".

- 5) **Move the cursor onto the **ENT** button, and left-click .**

7.1.3.1 Tune Indicator Adjustment)

Set the scale mark when the tune indicator bar reaches the maximum point.

Procedures

- 1) **Set a range of 48 NM or more.**
- 2) **Open the Serviceman Menu.**
- 3) **Perform the following menu open procedure to open the Tune Indicator Adjust menu.**



1. Adjust Menu

→

4. TXRX Adjustment

→

3. Tune Indicator Adjust

- 4) **Adjust the tune indicator adjustment value by operating the  /  button so that the tune indicator bar at the upper left of the display reaches a point of 80 to 90% of the maximum.**

For inputs to the value input screen, refer to Section 3.3.4.3 "Increasing or decreasing a numeric value".

- 5) **Move the cursor onto the  button, and left-click .**



With the NKE-2103 SCANNER UNIT:

For this model, perform Tune Peak Adjustment explained below. After the above adjustment procedure, perform the adjustment procedures below.

7.1.3.2 Tune Peak Adjustment

Adjust the tune indicator and echo peak.

Procedures

- 1) **Set a range of 48 NM or more.**
- 2) **Open the Serviceman Menu.**
- 3) **Perform the following menu open procedure to open the Tune Peak Adjustment menu.**



→ 

→ 

- 4) **Adjust the tune peak adjustment value by operating the  /  button so that the tune indicator bar at the upper left of the display is maximized.**

For inputs to the value input screen, refer to Section 3.3.4.3 "Increasing or decreasing a numeric value".

- 5) **Move the cursor onto the  button, and left-click.**

7.1.4 Bearing Adjustment

Make adjustment so that the bearing of the target measured with the ship's compass matches the bearing of the target echo on the radar display.

Procedures

- 1) Select **H Up** for the bearing presentation. Set video processing (PROC) to **PROC Off**.
- 2) Measure the bearing of an adequate target (e.g., a ship at anchor, a breakwater, or a buoy) relative to own ship's heading.
- 3) Open the Serviceman Menu.
- 4) Perform the following menu open procedure to open the Bearing Adjustment menu.

1. Adjust Menu

→

2. Bearing Adjustment

For inputs to the value input screen, refer to Section 3.3.4.3 "Increasing or decreasing a numeric value".

Make adjustment by the 0.1°.

- 5) Adjust the bearing adjustment value by operating the **+** / **-** button so that the target measured in step 2) is adjusted to the correct bearing.
- 6) Left-click the **ENT** button to determine the value.

7.1.5 Range Adjustment

Make adjustment so that the range of a target on the radar display is shown correctly.

Procedures

- 1) Search the radar display for a target of which range is already known.
- 2) Open the Serviceman Menu.

- 3) **Perform the following menu open procedure to open the Range Adjustment menu.**

1. Adjust Menu

→

3. Range Adjustment

For inputs to the value input screen, refer to Section 3.3.4.3 "Increasing or decreasing a numeric value".

- 4) **Adjust the range adjustment value by operating the / button so that the target measured in step 1) falls in the correct range.**
- 5) **Left-click the button to determine the value.**

7.1.6 Navigator Setting (Device)

Determine whether to connect navigators to the radar equipment.

Only the navigators set to ON here can be used.

Procedures

- 1) **Open the Serviceman Menu.**
- 2) **Perform the following menu open procedure to open the Device Installation menu.**

1. Adjust Menu

→

9. Next

→

3. Device Installation

- 3) **Select for navigators connected to the radar equipment, and for navigators not connected.**

Gyro : Gyro (via GYRO I/F)

Compass : Compass (Compliant with IEC61162)

GPS Compass : GPS Compass (JRC)

LOG : Log (via GYRO I/F)

2AXW : 2-axis log (Speed over water: Compliant with IEC61162)

2AXG : 2-axis log (Speed over ground: Compliant with IEC61162)

GPS : GPS (Compliant with IEC61162)

7.1.7 Setting of True Bearing Value

If GYRO I/F is used to input a gyro signal, the true bearing value indicated by the master gyro does not match the value indicated by the radar equipment only in a rare case. In this case, perform the following procedure to adjust the true bearing value of the radar equipment to the value of the master gyro.

Procedures

- 1) **Perform the following menu open procedure to open the true bearing value setting menu.**

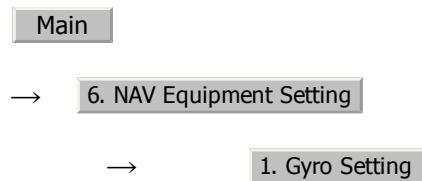

- 2) **Input the master gyro value to the value input screen.**

For inputs to the value input screen, refer to Section 3.3.4.3 "Increasing or decreasing a numeric value".

7.1.8 Antenna Height Setting (Antenna Height)

Set the height of radar antenna above sea level. Do not change this setting carelessly.

Procedures

- 1) **Measure the height of radar antenna above sea level in advance.**
- 2) **Open the Serviceman Menu.**
- 3) **Perform the following menu open procedure to open the Antenna Height setting menu.**

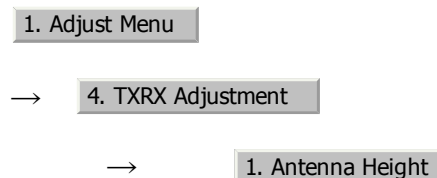

The Antenna Height menu will open.

- 4) **Select the setting that matches the antenna height measured in step 1).**

7.1.9 Setting of CCRP (CCRP Setting)

Set the own ship's CCRP location, radar antenna installation location, and GPS installation location.

CCRP : Up to four locations can be input. (One location selected when used)

Radar antenna: Up to eight radar antennas can be input. (Automatically selected in response to ISW operation)

GPS : Up to four locations can be input. (One location selected when used)

Procedures

- 1) **Measure the CCRP location, radar antenna location, and GPS antenna location in advance.**
- 2) **Open the Serviceman Menu.**
- 3) **Perform the following menu open procedure to open the CCRP Setting menu.**

2. Installation Menu

→ 4. CCRP Setting

- 4) **Specify the ship length for Length at the upper right of the CCRP Setting Menu, and the ship width for Beam.**
- 5) **Move the cursor onto the CCRP1 X, Y value, and left-click to input the CCRP1 location.**

When $X > 0$, the CCRP is on the starboard side of the ship.

When $X < 0$, it is on the port side.

- 6) **To input the second CCRP, click the CCRP2 button to display the CCRP2 X,Y value, and input the value in the same manner for step 5).**

Similarly, input the third and subsequent CCRPs.

- 7) **Repeat the above steps to input the GPS location(s) and radar antenna location(s).**
- 8) **If multiple CCRP locations and GPS locations are input, select the CCRP location and GPS location to be used by pressing the buttons at the upper left of the menu.**
- 9) **Click the 0.Exit to close the CCRP Setting menu.**

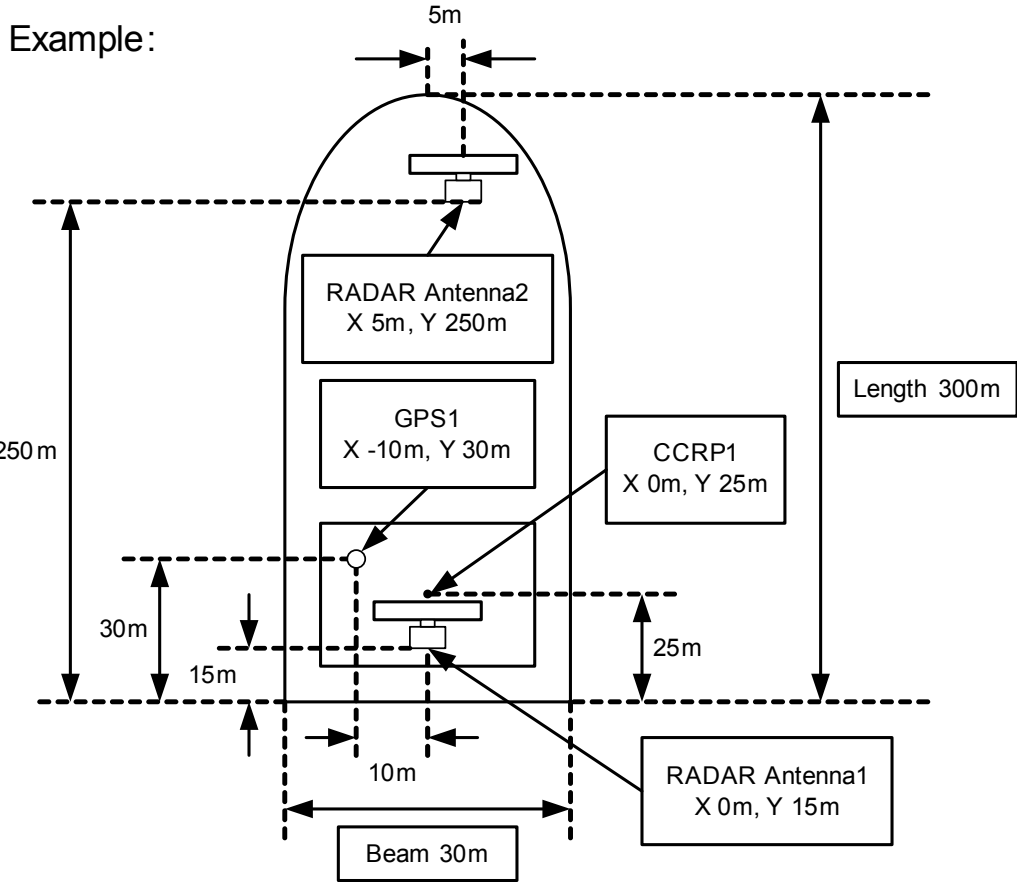

CCRP Settings

1. Select CCRP

2. Select GPS

Length
Beam

	X	Y
GPS1	-10.0	30.0 m
GPS2		m
GPS3		m
GPS4		m

	X	Y
RADAR Antenna1	0.0	15.0 m
RADAR Antenna2	5.0	250.0 m
RADAR Antenna3		m
RADAR Antenna4		m
RADAR Antenna5		m
RADAR Antenna6		m
RADAR Antenna7		m
RADAR Antenna8		m

	X	Y
CCRP1	0.0	25.0 m
CCRP2		m
CCRP3		m
CCRP4		m

0.

Y[m]

X[m]

(0,0)

- GPS
- RADAR Antenna
- CCRP

7

7.2 SETTINGS

This section describes the electrical adjustment procedures to be performed by service engineers during system installation.



CAUTION



- Do not carry out the adjustments of the equipment except authorized service persons. If wrong setting is carried out, this may cause unstable operation.
- Do not carry out the adjustments during navigation. Otherwise, the radar performance may be affected, resulting in an accident or trouble.

7.2.1 Communication Port Setting (COM Port Setting)

External sensor signals are input to the radar equipment through a communication port. The radar equipment has ten communication ports. For signals to be input from sensors or to be output to the sensors, communication ports need to be set in accordance with the sensors.

7.2.1.1 Baud Rate Setting (Baud Rate)

Set the baud rate of the signal to be input to the COM port.

Procedures

- 1) Open the Serviceman Menu.
- 2) Perform the following menu open procedure to open the Baud Rate setting menu.

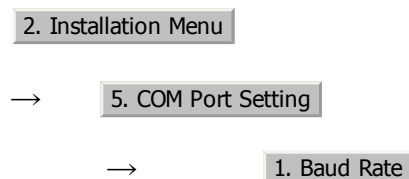

3) **Set the baud rate of the port to be set.**

1. COMPASS ^a :	4800(NMEA)/9600(NSK)/ 38400(fast NMEA) ^b bps
2. MAINTENANCE/LOG :	1200/ 4800 /9600/38400 bps
3. NAV1 :	1200/ 4800 /9600/38400 bps
4. NAV2 :	1200/ 4800 /9600/38400 bps
5. ALARM :	1200/ 4800 /9600/38400 bps
6. JARPA ^c :	1200/ 4800 /9600/38400 bps
7. AIS :	1200/4800/9600/ 38400 bps
8. ARPA ^d :	1200/ 4800 /9600/38400 bps
9. COM :	1200/ 4800 /9600/38400/115200 bps

- a. The compass port is a receive-only port that is dedicated to COMPASS signals.
- b. The bold values are factory-set.
- c. The JARPA port is a transmit-only port that is dedicated to JRC ARPA signals.
- d. The ARPA port is a transmit-only port.

7.2.1.2 **Reception Port Setting(RX Port)**

Set the numbers of ports for receiving signals from sensors.

There are two methods for receiving signals: specifying a port for each sensor, or using the automatic recognition function without specifying ports.

Procedures

- 1) **Open the Serviceman Menu.**
- 2) **Perform the following menu open procedure to open the RX Port setting menu.**

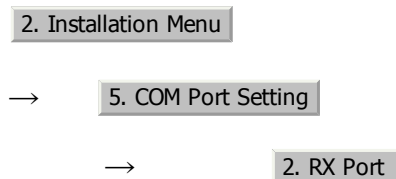

- 3) **Set a port for each sensor.**

Settable sensor signals	GPS、DLOG、Alarm、Depth、Temperature、Wind、Current、ROT、RSA
Selectable ports	When the automatic recognition function is used: AUTO
	When ports are specified: LOG、NAV1、NAV2、ALARM、ARPA、COM



7.2.1.3 Reception Sentence Setting (RX Sentence)

Set signal sentences to be received from sensors.

The system is factory-set for using all sentences. To receive only specified sentences, select **No Use** for sentences which are not necessary.

Procedures

- 1) **Open the Serviceman Menu.**
- 2) **Perform the following menu open procedure to open the RX Sentence setting menu.**

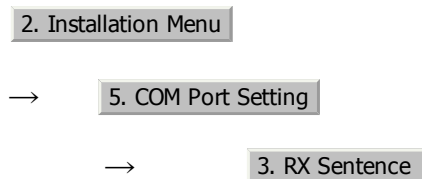

- 3) **Select the sentences to be used by the sensors to be set.**

Selection value: **Use** or **No Use** can be set for each sentence.

1. GPS(LL/COG/SOG) :	GGA/RMC/RMA/GNS/GLL/VTG
2. GPS(WPT/Time) :	GGA/RMC/RMB/BWC/BWR/ZDA
3. Depth :	DPT/DBK/DBT/DBS
4. Wind :	MWV/MWD
5. Current :	
→Data Set Number :	0-9. Set the number of the sentence to be used by Data Set Number. (Initial value 0)
→Layer A :	Set the number of the sentence to be used with layer A by Layer Number. (Initial value 3)
→Layer B :	Set the number of the sentence to be used with layer B by Layer Number. (Initial value 4)
→Layer C :	Set the number of the sentence to be used with layer C by Layer Number. (Initial value 5)

7.2.1.4 Transmission Port Setting (TX Port)

For each sentence, set a communication port through which signals are transmitted to sensors.

Procedures

- 1) **Open the Serviceman Menu.**
- 2) **Perform the following menu open procedure to open the TX Port setting menu**

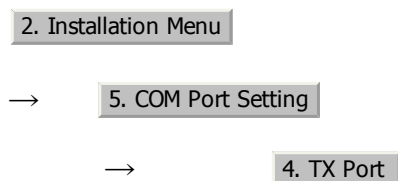

- 3) **Select the communication port through which the sentence to be set is output.**

Settable sentences	TTM(TT), TLL(TT), TTD(TT), TLB(TT), OSD, RSD, ALR, ACK, TTM(AIS), TLL(AIS), TTD(AIS), TLB(AIS), RemoteMaintenance, JRC-ARPA, APB, BOD, GGA, GLL, RMC, RMB, VTG, XTE, BWC, HDT, THS
Selectable ports	MAINTENANCE, NAV1, NAV2, ALARM, JARPA, ARPA, COM

- 4) **Select the output format, talker, and transmission interval.**

Signals for which the above items can be set:

Item	Name	Option
NMEA0183 Output Format	APB, BOD, GGA, GLL, RMC, RMB, VTG, XTE, BWC, HDT	V1.5 V2.0 V2.3^a
NMEA0183 Talker ^b	APB, BOD, RMB, XTE, BWC, HDT, THS	STANDARD : The talker is RA . GP : The talker is GP.
NMEA0183 TX Interval	APB, BOD, GGA, GLL, RMC, RMB, VTG, XTE, BWC, HDT, THS	Set an interval in the range 1 to 9 seconds.

- a. The **bold** values are factory-set.
- b. For TTM, TLL, OSD, RSD, and ALR, the talker is always RA .
For GGA, GLL, RMC, and VTG, the talker is always GP.



7.2.2 Sector Blank Setting (Sector Blank)

In order not to display radar echoes, set a sector range and stop transmission in the bearing range. Three types of sectors can be created.

The sector blank function operates in the relative bearing with the bow as the benchmark.

7.2.2.1 Sector Blank Function On/Off (Sector1,2 and 3)

Procedures

- 1) Open the Serviceman Menu.
- 2) Perform the following menu open procedure to open the Sector Blank setting menu.

2. Installation Menu

→ 3. Sector Blank

- 3) Set the sector blank number **Sector 1** , **Sector 2** , or **Sector 3** with which the sector blank function operates.

The system allows the use of up to three sector blank areas.

Set each sector blank area to on or off.

On : The sector blank function of the number is operated.

Off : The sector blank function of the number is stopped.

7.2.2.2 Sector Blank Area Creation (Make Sector 1,2,3)

Procedures

- 1) Open the Serviceman Menu.
- 2) Perform the following menu open procedure to open the Sector Blank setting menu.

2. Installation Menu

→ 3. Sector Blank

- 3) Select the sector blank number (**Make Sector 1** to **Make Sector 3**) for sector creation, and click the **Make Sector** button in the menu.

The selected sector blank will be made.

- 4) **Set the starting azimuth of the sector blank by operating the [EBL] dial, and left-click the button.**

The start angle of the sector blank will be set.

- 5) **Set the ending azimuth of the sector blank by operating the [EBL] dial, and left-click the button.**

The end angle of the sector blank will be set.

7.2.3 TNI Blank Setting (TNI Blank)

Set a sector range and stop tuning operation in the bearing range.

If a structure such as the mast is close to the radar antenna, automatic tuning operation may become unstable. In this case, set a TNI blank in the direction of the structure in order to stabilize the tuning operation.

Only one type of a sector can be created. The TNI blank function operates in the relative bearing with the bow as the benchmark.

7.2.3.1 TNI Blank Function On/Off (Sector)

Procedures

- 1) **Open the Serviceman Menu.**
- 2) **Perform the following menu open procedure to open the TNI Blank setting menu.**

→

→

- 3) **Select the item in the menu, and turn on or off the TNI blank function.**

: The TNI blank function is operated.

: The TNI blank function is stopped.

7.2.3.2 TNI Blank Area Creation (Make Sector)

Procedures

- 1) **Open the Serviceman Menu.**

- 2) **Perform the following menu open procedure to open the Sector Blank setting menu.**

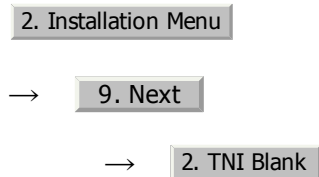

- 3) **Left-click the 2. Make Sector button in the menu.**

The selected sector blank will be made.

- 4) **Set the starting azimuth of the TNI blank by operating the [EBL] dial, and left-click the ENT button.**

The start angle of the TNI blank will be set.

- 5) **Set the ending azimuth of the TNI blank by operating the [EBL] dial, and left-click the ENT button.**

The end angle of the TNI blank will be set.

7.2.4 Setting of Bearing Pulses from Scanner Unit (Output Pulse)

Set the output value of bearing pulses from the scanner unit. The system can set 2048 pulses or 4096 pulses. This setting is enabled only when the scanner unit of 25 or 30 kW is used.

Procedures

- 1) **Open the Serviceman Menu.**
- 2) **Perform the following menu open procedure to open the Output Pulse setting menu.**

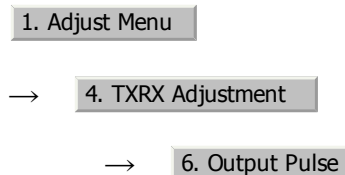

- 3) **Set the number of pulses to be output by the scanner unit.**

^a :2048 pulses per antenna rotation (Recommended value)

:4096 pulses per antenna rotation

a. If a 10 kW antenna is used, 2048 is always set.

7.2.5 Slave Mode Setting (Master/Slave)

Place the system in the Slave mode when it is to be operated as the sub-display that displays radar echoes by using radar signals from other radar equipment.

The input value of externally input bearing pulses can be set. The system can set 2048 pulses or 4096 pulses.

7.2.5.1 Slave Mode Setting (Master/Slave)

Procedures

- 1) Open the Serviceman Menu.
- 2) Perform the following menu open procedure to open the installation setting menu.

2. Installation Menu

- 3) Select Slave for the item 2. Master Slave in the menu.

Master :The system operates as radar equipment while the own antenna is connected.

Slave :The system operates as a sub-display while the signal cable of other radar equipment is connected.

7.2.5.2 Setting of Input Bearing Pulse (Input BP Pulse)

Procedures

- 1) Open the Serviceman Menu.
- 2) Perform the following menu open procedure to open the second page of the installation setting menu.

2. Installation Menu

→ 9. Next

- 3) Set the number of pulses for the item 1. Input BP Count in the menu.

2048 : 2048 pulses per antenna rotation

4096 : 4096 pulses per antenna rotation

7.2.6 Language Setting (Language)

The system is designed to switch between display languages, Japanese and English.

Procedures

- 1) **Open the Serviceman Menu.**
- 2) **Perform the following menu open procedure to open the language setting menu.**

2. Installation Menu

→

8. Language

- 3) **Select the language to be used.**

1. English

2. Japanese

3. Other ^a

- a. Other is an option to display character strings created by our overseas agents. Ask the overseas agent or our sales department if your language is supported. To determine the selected language, turn the power off, and then turn it on.

7.2.7 Date Time Setting

To display time, the local time, local date, and time-zone difference must be set.

However, if the "ZDA" sentence of NMEA0183 is received, time can be automatically displayed.

Procedures

- 1) **Perform the following menu open procedure to open the language setting menu.**

Main

→

7. Sub Menu

→

6. Date Time Setting

The Date Time Setting menu will open.

- 2) **Set information about date and time**
 - 2)-1. UTC/LMT (Time display system)

UTC : Universal Time Coordinate

LMT : Local Mean Time

2)-2. LMT Date

Input the date in local time.

2)-3. LMT Time

Input the date in local time.

2)-4. Time Zone

Input the time-zone difference between the universal time and local time.

2)-5. Display Style

Set one of the following date display formats.

例 : 2007-12-31

例 : DEC 31, 2007

例 : 31 DEC, 2007

2)-6. Synchronize with GPS

A ZDA sentence sent by the GPS is used, thereby displaying time synchronized with the GPS time.

^a : Time synchronized with the GPS time

: Time not synchronized with the GPS time

a. If On is selected for this item but a ZDA sentence is not input, the system internal clock function is used to display the date and time.

7.2.8 Input Installation Information

The system can input installation information.

Procedures

- 1) **Open the Serviceman Menu.**
- 2) **Perform the following menu open procedure to open the language setting menu.**

→

- 3) **Input the installation information.**

For the input method on the numeric value and character input screens, see Section 3.3.4 "Operation on Numeric Value, Latitude / Longitude and Character Input menu".

Input the date of installed system.

Input the name of installation personel.

Input the name of radar installer.

7.2.9 Setting the Alarm System

7.2.9.1 Setting the reset interval (Reset Interval)

This function enables the control of WMRST terminal (on the terminal board circuit).The reset signal is turned on when operation in a set period of time.

Procedures

- 1) **Open the Serviceman Menu.**
- 2) **Perform the following menu open procedure to open the Reset Interval menu.**

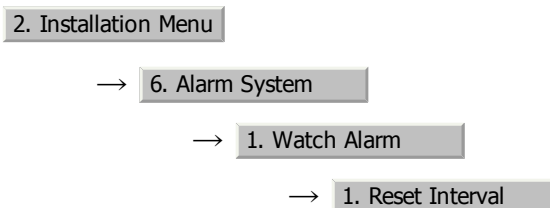

- 3) **Input the value to be set.**

For how to input numeric data on the numeric value input screen, see Section 3.3.4 "Operation on Numeric Value, Latitude / Longitude and Character Input menu".

7.2.9.2 Setting the Trackball Threshold

This function enables the control of WMRST terminal (on the terminal board circuit).

The reset signal is turned off when trackball is moved, that caused by vibration.If trackball move distance go over the threshold (dot unit) when reset signal is turned on.

Procedures

- 1) **Open the Serviceman Menu.**
- 2) **Perform the following menu open procedure to open the Trackball Threshold menu.**

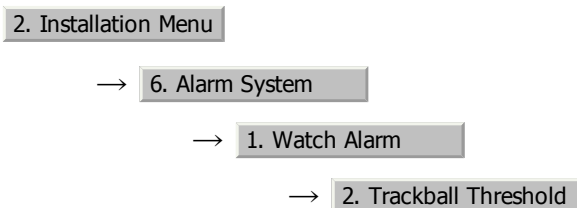

- 3) **Input the value to be set.**

For how to input numeric data on the numeric value input screen, see Section 3.3.4 "Operation on Numeric Value, Latitude / Longitude and Character Input menu".

7.2.9.3 Setting the relay output (Relay Output)

This function enables the control of ARPAALM terminal (on the terminal board circuit).

Procedures

- 1) **Open the Serviceman Menu.**
- 2) **Perform the following menu open procedure to open the Relay Output menu.**

2. Installation Menu

→ 6. Alarm System

→ 2. Relay Output

- 3) **Left-click the 1. Relay Output Mode button in the menu.**

The Relay Output mode is switched.

Continuous : The output is continuously controlled.

Intermittent : The output is intermittently controlled.

- 4) **Click the item button corresponding to the item to be changed.**

The item can be turned on / off.

On : The relay output is turned on when alarm have issued.

Off : The relay output is not turned on when alarm have issued.

2. TT CPA/TCPA : There is a dangerous target. (tracked target)

3. AIS CPA/TCPA : There is a dangerous target. (AIS target)

4. New Target : A new target is acquired in the automatic acquisition zone.

5. Lost : There is a lost target. (Target Tracking / AIS).

7.2.9.4 Setting the ALR output (ALR Output)

This function enables the control of ALR port (See Section 7.2.1 "Communication Port Setting (COM Port Setting)").

Procedures

- 1) **Open the Serviceman Menu.**

- 2) **Perform the following menu open procedure to open the ALR Output menu.**

2. Installation Menu

→ 6. Alarm System

→ 2. Relay Output

- 3) **Click the item button corresponding to the item to be changed.**

The item is turned on / off.

On : The ALR sentence is output when alarm have issued.

Off : The ALR sentence is not output when alarm have issued.

1. System Alarm : The internal alarm.

2. TT/AIS Alarm : Target Tracking Alarms and AIS Function Alarms.

7.2.9.5 Setting the External Acknowledgement (External ACK Setting)

This function enables the control of system when ACK sentence have received.

Procedures

- 1) **Open the Serviceman Menu.**
- 2) **Perform the following menu open procedure to open the External ACK Setting menu.**

2. Installation Menu

→ 6. Alarm System

→ 5. External ACK Setting

- 3) **Click the item button corresponding to the menu to be changed.**

Critical Alarm : CPA/TCPA alarm.

Normal Alarm : Exept Critical Alarm.

4) **Click the item button corresponding to the item to be changed.**

The item is switched.

Audio : Setting of alarm sound.

→ **On** : The alarm sound is not stopped when acknowledgement have received.

→ **Off** : The alarm sound is stopped when acknowledgement have received.

Indication : Setting of alarm indication.

→ **Lightning** : The alarm indication brinking is stopped when acknowledgement have received.

→ **Brinking** : The alarm indication brinking is not stopped when acknowledgement have received..

Acknowledge State : Setting of ALR sentence.

→ **A;ACK** : Add acknowledgement to ALR sentence.

→ **V;UNACK** : Add no acknowledgement (unrecognized) to ALR sentence.

7.2.9.6 Setting the Alarm Buzzer (Sound Output Mode)

This function enables the control of alarm buzzer.

Procedures

- 1) **Open the Serviceman Menu.**
- 2) **Perform the following menu open procedure to open the External ACK Setting menu.**

2. Installation Menu

→ 6. Alarm System

→ 4. Sound Output Mode

- 3) **Select the function to be used.**

On , **Off1** and **Off2**

Setting and Alarm Function

Alarm Setting	Operation	Operation Miss	CPA/TCPA	New Target	Lost	NAV	System	ISW
On					①			
Off1		①				②		
Off2		①		③		①	②	①

①: Followed by Buzzer Volume menu setting.

②: Alarm Buzzer is turned off.

③: If Relay Output menu is turned on when Alarm Buzzer is turned off. If Relay Output menu is turned off when Alarm Buzzer is turned on.

For how to setting Buzzer Volume menu, see Section 3.8.6 "Adjust Sound Volume (Buzzer Volume)".

7.3 ADJUSTMENT

This section describes the electrical adjustment procedures to be performed by service engineers during system installation.



CAUTION



Do not carry out the adjustments of the equipment except authorized service persons. If wrong setting is carried out, this may cause unstable operation.

Do not carry out the adjustments during navigation. Otherwise, the radar performance may be affected, resulting in an accident or trouble.

7.3.1 Noise Level Adjustment (Noise Level)

7.3.1.1 Noise Level Adjustment for Signal Processing

Procedures

- 1) **Open the Serviceman Menu.**

- 2) **Perform the following menu open procedure to open the noise level adjustment menu.**

9. RADAR/TT Initial Setup

→ 1. Signal Processing

→ 1. Echo Noise Level

- 3) **Increase/decrease the noise level adjustment value.**

The noise level is factory-set. (Initial value: 140)

After system installation, a great change in the noise level adjustment value should be avoided; it should be fine adjusted within ± 5 .

7.3.1.2 Noise Level Adjustment Mode (Setting Mode)

A noise level is factory-adjusted while this mode is turned on.

Procedures

- 1) **Open the Serviceman Menu.**
- 2) **Perform the following menu open procedure to open the noise level adjustment menu.**

9. RADAR/TT Initial Setup

→ 1. Signal Processing

→ 2. Setting Mode

The noise level adjustment mode is switched between on and off.

Factory-adjustment method

- The noise level adjustment value is once decreased to about 130.
- While the noise level adjustment value is gradually increased, the value with which radar echoes start turning yellow is determined as the set value.
- The noise level adjustment mode is turned off when the adjustment is finished.

7.3.2 Adjustment of Target Tracking Function (TT)

7.3.2.1 Vector Constant Adjustment (Vector Constant)

Adjust the vector follow-up performance of the target tracking function.

The vector constant is adjusted to an optimal value, so do not change it carelessly.

Attention

Do not change the set value carelessly.

The vector constant shall be set to 5 normally. If the vector constant value is higher, a target's vector will be better followed up when the target and own ship change their course or speed, but the vector accuracy will be lower on the contrary.

Procedures

- 1) **Open the Serviceman Menu.**
- 2) **Perform the following menu open procedure to open the Vector Constant adjustment menu.**

9. RADAR/TT Initial Setup

→ 2. TT

→ 1. Vector Constant

The window for setting vector constants will appear.

3) **Input the value to be set.**

For how to input numeric data on the numeric value input screen, see Section 3.3.4 "Operation on Numeric Value, Latitude / Longitude and Character Input menu".

7.3.2.2 Quantization Level Adjustment (Video TD Level)

Use the target tracking function (TT) to adjust the level of the signal to be recognized as a target. If a small value is set, even weak target signals will be input to the target detection circuit of the target tracking function. However, many unnecessary signals are also input, which may cause unstable target acquisition or tracking. It is important to set a value four or five greater than the value with which unnecessary signals are detected.

The quantization level is adjusted to an optimal value, so do not change it carelessly.



CAUTION



Do not change the set quantization level carelessly. If the level deviates from the proper value, the target acquisition and tracking functions will deteriorate. Otherwise, this may cause accidents.

Procedures

- 1) **Open the Serviceman Menu.**
- 2) **Perform the following menu open procedure to open the target tracking setting menu.**

9. RADAR/TT Initial Setup

→ 2. TT

- 3) **To change the quantization level of the automatic acquisition area, specify the item 2. Video TD Level in the menu. To change the quantization level of tracking and manual acquisition, specify the item 3. Video High Level .**

- 4) **Input the value to be set.**

7.3.3 Main Bang Suppression Level Adjustment (MBS)

Main Bang Suppression is adjusted to suppress main bang, a reflection signal from 3D circuit including wave guide tube, that generally appears as a circular image focusing on the center of the radar display. Optimum adjustment allows main bang image to remain lightly on the display.



CAUTION



Do not change this adjusted level carelessly.

Incorrect adjustment may erase targets in point-blank range and cause collision, resulting in death or serious injury.

7.3.3.1 Adjustment of Main Bang Suppression Level (MBS Level)

Procedures

- 1) **Open the Serviceman Menu.**
- 2) **Perform the following menu open procedure to open the MBS level adjustment menu.**

9. RADAR/TT Initial Setup

→ 3. MBS

→ 1. MBS Level

- 3) **Set the radar as follows:**
 - Set the radar range to 0.125 NM.
 - Set the radar video enhance function (ENH) to OFF.
 - Set the image processing (PROC) to OFF.
 - Turn the [RAIN] control to the minimum position (fully to the left).
 - Turn the [GAIN] control to the maximum position (fully to the right).
 - Turn the [SEA] control to achieve the strength with which main bang can be judged.
- 4) **Adjust the value so that the main bang can be erased.**

7.3.3.2 Adjustment of Main Bang Suppression Area (MBS Area)

Procedures

- 1) Open the Serviceman Menu.
- 2) Perform the following menu open procedure to open the MBS Area adjustment menu.

9. RADAR/TT Initial Setup

→ 3. MBS

→ 2. MBS Area

- 3) Set the radar as follows:
 - Set the radar range to 0.125 NM.
 - Set the radar video enhance function (ENH) to OFF.
 - Set the image processing (PROC) to OFF.
 - Turn the [RAIN] control to the minimum position (fully to the left).
 - Turn the [GAIN] control to the maximum position (fully to the right).
 - Turn the [SEA] control to achieve the strength with which main bang can be judged.
- 4) Adjust the value so that the main bang can be erased.

7.3.4 Adjustment of Performance Monitor

After replacement of either of the following units, adjust the performance monitor according to the procedures in this section:

- Performance monitor
- Antenna unit

7.3.4.1 Transmission Monitor Adjustment (MON Adjustment)

Adjust the circuit for monitoring the transmission performance of the radar equipment.

Procedures

- 1) If the performance monitor is equipped with an inter-switch function, set it as the master display unit.
- 2) Open the Serviceman Menu.
- 3) Perform the following menu open procedure to open the Performance Monitor Adjustment menu.

1. Adjust Menu

→ 4. TXRX Adjustment

→ 4. MON Adjustment

- 4) Increase or decrease the adjustment value so that the farthest point of the performance monitor pattern touches the 18.0 nm line on the chart.

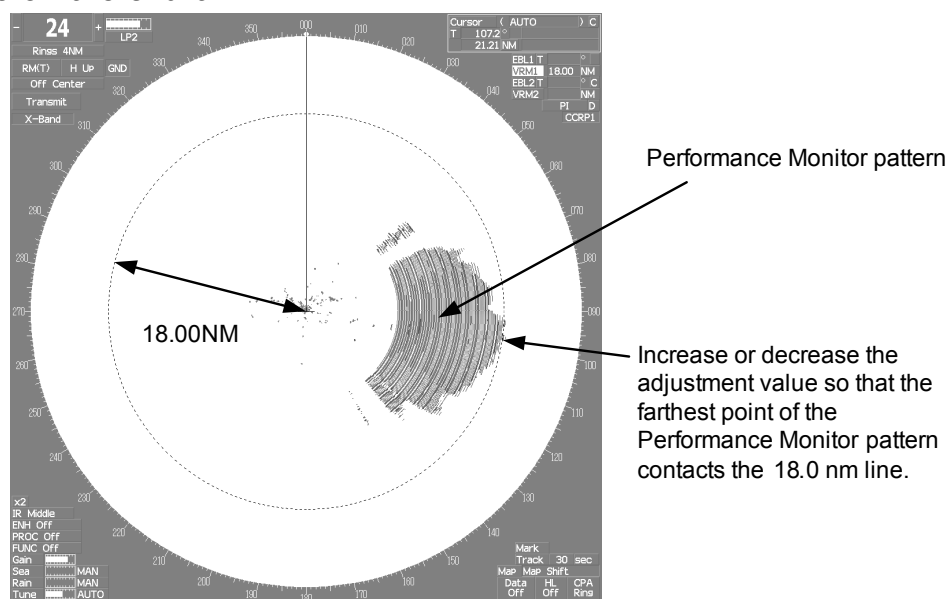

Fig 7-2: MON Adjustment

7.3.4.2 Reception Monitor Adjustment (MON Indicator Adjustment)

Adjust the circuit for monitoring the reception performance of the radar equipment.

Procedures

- 1) If the performance monitor is equipped with an inter-switch function, set it as the master display unit.
- 2) Open the Serviceman Menu.
- 3) Perform the following menu open procedure to open the performance monitor Indicator Adjustment menu.

1. Adjust Menu

→ 4. TXRX Adjustment

→ 4. MON Adjustment

- 4) Increase or decrease the adjustment value so that the performance monitor level indicator will be adjusted to "8".

MON 

- 5) Attach the INFORMATION LABEL provided with the performance monitor to an appropriate position on the display unit.
- 6) Write the performance monitor bar value check date to the INFORMATION LABEL.



During performance monitor adjustment, all acquisitions by the target tracking function are released.

The released target acquisitions are not recovered.

7.4 MAINTENANCE MENU

This item is provided for equipment maintenance, including settings of antenna safety switch, master reset, etc.



CAUTION

Only our service engineers are to make the adjustment. Neglecting this caution may cause accidents and failures.

Do not make the adjustments during navigation. Otherwise, adjustments may affect the radar functions, causing accidents and failures.

7.4.1 Antenna Safety Switch (Safety Switch)

Use this switch to measure the transmission/reception performance while the antenna is in stopped state.

Procedures

- 1) **Open the Serviceman Menu.**
- 2) **Perform the following menu open procedure to open the Safety Switch setting menu.**

3. Maintenance Menu

→ 1. Safety Switch

- 3) **Select the item to be set.**

Set operation when the antenna safety switch is turned off.

1. TX-OFF : The transmitter stops transmission. The screen on the display unit remains in transmission state.

2. Standby : (Normal setting) The transmitter stops transmission. The screen on the display unit is placed in standby state.

3. TX-ON : The transmitter continues transmission. The screen on the display unit remains in transmission state. In this case, however, an error such as a bearing signal failure occurs because the safety switch is turned off.

- 4) **Change the setting back to 2. Standby when the work is finished.**

7.4.2 Initialization of Memory Area(Area Initial)

If system operation is unstable, it may be stabilized by initializing the memory area. To initialize the memory area, follow the procedure in this section. The memory area is reset to the factory setting when initialized.

7.4.2.1 Partial Master Reset

Procedures

- 1) **Open the Serviceman Menu.**
- 2) **Perform the following menu open procedure to open the Partial Master Rest operation menu for the memory area.**

3. Maintenance Menu

→ 2. Area Initial

→ 1. Partial Master Reset

- 3) **Select the items to be initialized.**

1. Serviceman Menu : The set values in the Serviceman menu are initialized.

2. Except Serviceman Menu : The set values not in the Serviceman menu are initialized.

3. User Setting : The user-set values are initialized.

4. TT Setting : The set values for the target tracking function are initialized.

5. AIS Setting : The set values for the AIS display function are initialized.

6. Day/Night : The color scheme and brilliance setting for the day/night mode are initialized.

- 4) **Select 1. Yes in the Confirmation Menu.**

The memory areas of specified items are initialized, and the system is restarted.

7.4.2.2 All Master Reset

Procedures

- 1) **Open the Serviceman Menu.**
- 2) **Perform the following menu open procedure to open the All Master Rest operation menu for the memory area.**

3. Maintenance Menu

→ 2. Area Initial

→ 2. All Master Reset

- 3) **Select 1. Yes in the Confirmation Menu.**

The whole memory area is initialized, and the system is restarted.

7.4.3 Save of Internal Memory Data (Card1/2)

The system can save internal memory data such as item settings in all menus onto a flash memory card. If the radar processing circuit in the system has been replaced, the set values before the circuit replacement can be restored by reading the set values you saved before the replacement.

To save the internal memory data onto a flash memory card (option), the card must be inserted in card slot beforehand.

7.4.3.1 Copying of Internal Settings onto Card (Internal To Card1/2)

Save the internal memory data, such as item settings in menus, onto a flash memory card.

The internal memory data should be saved at completion of system setting, and the operation condition should be saved periodically.

Procedures

- 1) **Open the Serviceman Menu.**
- 2) **Perform the following menu open procedure to open the Internal to Card2 menu.**

3. Maintenance Menu

→ 3. Internal To Card2

- 3) **Select 1. Yes in the Confirmation Menu.**

The internal memory data is saved on the flash memory card.

7.4.3.2 Reading of Internal Settings from Card (Card1/2 To Internal)

Read the saved memory data from the flash memory card into the system memory.

Perform the read operation in order to return the system to the previous operation condition after replacement of the radar processing circuit in the system.

Procedures

- 1) **Open the Serviceman Menu.**
- 2) **Perform the following menu open procedure to open the Card2 to Internal menu.**

3. Maintenance Menu

→ 4. Card2 To Internal

- 3) **Select 1. Yes in the Confirmation Menu.**

The memory data is read from the flash memory card into the system memory.

After the internal memory area is updated, the system is restarted.

7.4.4 Restoration of Scanner Unit Operation Time (TXRX Time)

The system adds up the following operation time and contains it in the scanner unit:

- Transmission time
- Motor run time

Clear the above total time when the magnetron or scanner unit motor is replaced.

7.4.4.1 Clear of Motor Run Time (Clear TX Time)

Clear the scanner's motor run time.

Perform the following procedure to clear the motor run time when the scanner motor is replaced.

Procedures

- 1) **Open the Serviceman Menu.**
- 2) **Perform the following menu open procedure to open the Clear Motor Time menu.**

3. Maintenance Menu

→ 5. TXRX Time

→ 1. Clear TX Time

- 3) **Select 1. Yes in the Confirmation Menu.**

The motor run time in the TXRX's internal control circuit is cleared to 0.

7.4.4.2 Save of Antenna Time (Clear Motor Time)

Save the following scanner unit time data from the scanner unit into the display unit.

Perform the following procedure to inherit the scanner unit time data when the TXRX's internal control circuit is replaced.

Procedures

- 1) **Open the Serviceman Menu.**
- 2) **Perform the following menu open procedure to open the Clear Motor Time menu.**

3. Maintenance Menu

→ 5. TXRX Time

→ 2. Clear Motor Time

- 3) **Select 1. Yes in the Confirmation Menu.**

The motor run time in the TXRX's internal control circuit is cleared to 0.

7.4.4.3 Save of Scanner Unit Time (TXRX To Display Unit)

Save the following scanner unit time data from the scanner unit into the display unit.

Perform the following procedure of 7.4.4.4 to inherit the scanner unit time data when the TXRX's internal control circuit is replaced.

Procedures

- 1) **Open the Serviceman Menu.**
- 2) **Perform the following menu open procedure to open the TXRX to Display Unit menu.**

3. Maintenance Menu

→ 5. TXRX Time

→ 3. TXRX To Display Unit

- 3) **Select 1. Yes in the Confirmation Menu.**

The scanner unit time data in the TXRX's internal control circuit is saved transferred to the display unit.

7.4.4.4 Restoration of Antenna Time (Display Unit To TXRX)

Restore the antenna time data from the display unit into the antenna's internal control circuit.

Perform the above procedure of 7.4.4.3 to inherit the antenna time data when the antenna's internal control circuit is replaced.

Procedures

- 1) **Open the Serviceman Menu.**
- 2) **Perform the following menu open procedure to open the Display Unit to TXRX menu.**

3. Maintenance Menu

→ 5. TXRX Time

→ 4. Display Unit To TXRX

- 3) **Select 1. Yes in the Confirmation Menu. 実行確認画面で、を選択する。**

The scanner unit time data in the display unit is restored transferred to the antenna's internal control circuit.

7.4.5 Update of Character String Data (String Data Update)

The system is designed to transfer and display external character strings as the second language display. The second language is factory-set to "Japanese."

Ask our agent or sales department for the supply of character strings to be updated.

To update character strings, the flash memory card (option) containing the character string file must be inserted in card slot 2.

Procedures

- 1) **Open the Serviceman Menu.**
- 2) **Perform the following menu open procedure to open the String Data Update menu.**

3. Maintenance Menu

→ 6. String Data Update

- 3) **Select 1. Yes in the Confirmation Menu.**

The character string file on the flash memory card is read into the system, and the second language area is updated.

To display the read character strings in the second language, select Other in the menu shown in Section 7.2.6 "Language Setting (Language)".

SECTION 8

COUNTERMEASURES FOR TROUBLE AND ADJUSTMENT

COUNTERMEASURES FOR TROUBLE AND ADJUSTMENT

8.1	ROUTINE MAINTENANCE	8-1
8.2	MAINTENANCE ON EACH UNIT	8-2
8.2.1	Scanner Unit NKE-1125/1129/1130/1139/2103/2254	8-2
8.2.2	Wave Guide Tube (JMA-9123-7XA/9XA)	8-4
8.2.3	Coaxial Cable (JMA-9133-SA)	8-4
8.2.4	Transmitter Receiver Unit (NTG-3225/3230)	8-5
8.2.5	Display Unit (NCD-4990)	8-5
8.3	PERFORMANCE CHECK	8-6
8.3.1	Check Performance on Test Menu	8-6
8.3.1.1	Self-diagnosis function (Self Test)	8-7
8.3.1.2	Monitor Test	8-9
8.3.1.3	Operation Unit Test (Keyboard Test)	8-9
8.3.1.4	Check of the Performance Monitor (MON Display)	8-10
8.3.1.5	System Alarm Log display	8-10
8.3.1.6	System Information	8-11
8.3.1.7	Magnetron Current	8-11
8.4	REPLACEMENT OF MAJOR PARTS	8-12

8.4.1	Parts Required for Periodic Replacement	8-13
8.4.2	Replacement of magnetron	8-13
8.4.2.1	Scanner Unit NKE-1130	8-14
8.4.2.2	Scanner Unit NKE-2254, NKE-1125	8-16
8.4.2.3	Scanner Unit NKE-2103	8-19
8.4.2.4	Transmitter Receiver Unit NTG-3230	8-21
8.4.2.5	Transmitter Receiver Unit NTG-3225	8-24
8.4.3	Replacement of Motor	8-28
8.4.3.1	Scanner Unit NKE-1139/1130	8-28
8.4.3.2	Scanner Unit NKE-1125/2254	8-30
8.4.3.3	Scanner Unit NKE-2103	8-31
8.4.4	Replacement of LCD Monitor	8-33
8.4.4.1	Display Unit NCD-4990	8-33
8.4.5	Replacement of Backup Battery	8-36
8.4.5.1	About the Battery Alarm	8-36
8.4.5.2	How to Replacement of Backup Battery	8-36

8.1 ROUTINE MAINTENANCE



WARNING



- **Never carry out internal inspection or repair work of the equipment by users. Inspection or repair work by unauthorized personnel may result in fire hazard or electric shock. Ask the nearest branch, business office or a dealer for inspection and repair.**



- **Turn off the main power before maintenance work. Otherwise, an electric shock may result.**



- **Turn off the main power before cleaning the equipment. Especially, make sure to turn off the indicator if a rectifier is used. Otherwise, equipment failure, or death or serious injury due to electric shock may result, because voltage is outputted from the rectifier even when the radar is not operating.**

For operating the radar equipment in the good conditions, it is necessary to make the maintenance work as described below. If maintenance is made properly, troubles will reduce. It is recommended to make regular maintenance work.

Common points of maintenance for each unit are as follow:

- Clean the equipment.

Remove the dust, dirt, and sea water rest on the equipment cabinet with a piece of dry cloth.

Especially, clean the air vents with a brush for good ventilation.





8.2

MAINTENANCE ON EACH UNIT

8.2.1 Scanner Unit NKE-1125/1129/1130/1139/2103/2254



WARNING

- 
 - Turn off the main power source before starting maintenance. Otherwise, an electric shock or injury may be caused.
- 
 - Do not touch the radiator. Even if the power is turned off, the radiator may be rotated by the wind.
- 
 - Turn "OFFⁱ" the safety switch to stop the scanner unit. (Refer to Section 1.4 "EXTERIOR DRAWINGS".) Otherwise, you may be injured if touching the rotating scanner unit by accident.
- 
 - Do not touch the radiator. Even if the power is turned off, the radiator may be rotated by the wind.

i. After the work, turn "ON" the scanner unit safety switch.

a. Precautions in Mounting the Cover

When the cover is removed for regular checkup and replacement of parts and refitted after such work, the procedures of fastening bolts shall be taken with the following precautions:

- 1) **The proper fastening torque of the fitting bolts (M8) is 1176 to 1470 N/cm (120 to 150kgf/cm) (which makes the inside water-tight and protects the packings against permanent compressive strain).The packings start producing from the cover at a torque of approximately 1470N/cm (150kgf/cm). Do not fasten the bolts with a torque exceeding the specified value. Otherwise, the screws may be broken.**
- 2) **Use an offset wrench of 11 mm X 13 mm or a double-ended wrench of 13 mm X 17 mm (not longer than 200 mm).**
- 3) **Screw all the bolts by hand first to prevent them playing, then fasten them evenly in order not to cause one-sided fastening. (Fasten the bolts with 25% of the required torque at the first step.)**

*Fasten the bolts in the diagonal order.

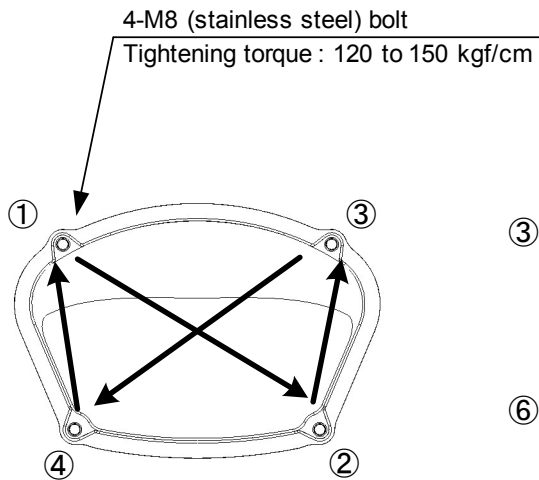

Bolt Tightening Procedure of
NKE-1125/1129/2254 Cover

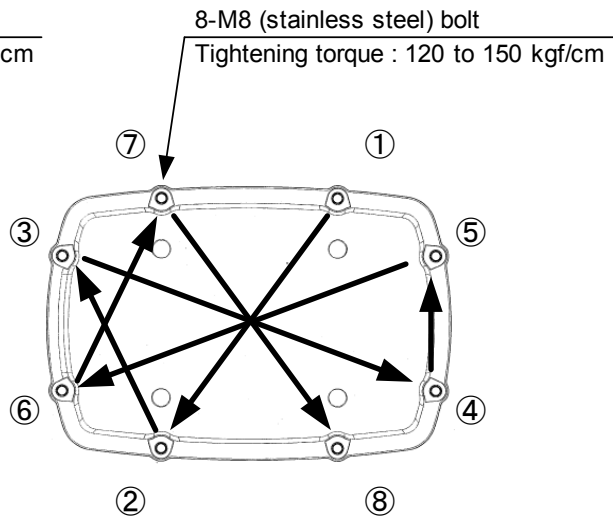

Bolt Tightening Procedure of
NKE-1130/1139 Cover

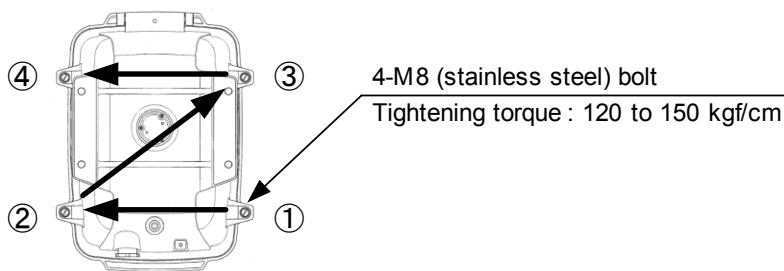

Bolt Tightening Procedure of
NKE-2103 Cover

b. Radiator

Attention

- If the radiator front face (radiation plane) is soiled with smoke, salt, dust, paint or birds' droppings, wipe it with a piece of soft cloth wetted with alcohol or water and try to keep it clean at all times. Otherwise, radar beam radiation may attenuate or reflect on it, resulting in deterioration of radar performance.
- Never use solvents of gasoline, benzine, trichloroethylene and ketone for cleaning. Otherwise, the radiation plane may deteriorate.

Check up and clean the radiator.

c. Rotating section

c-1 Supply Oil Seal

When there is not a grease nipple, the replenishment of grease oil is unnecessary.

Remove the cap on the grease nipple located on the side of the X band radar or on the front of S band radar at which the radiator is supported, and grease with a grease gun. Make the oiling every six months. The oil quantity shall be approximately 100 g, which is as much as the grease comes out of the oil seal. Use the grease of Mobilux 2 of Mobil Oil.

c-2 Oiling gears

Apply grease evenly to the tooth surfaces of the main shaft drive gear and the encoder drive gear with a spreader or brush. Oiling in short intervals is more effective to prevent the gears from wear and tear and extend their service life, but oil at least every six months.

Use Mobilux2 of Mobile Oil.

c-3 Mounting legs

Check the mounting legs and mounting bolts of the antenna unit case for corrosion at intervals and maintain them to prevent danger. Apply paint to them once a half year because painting is the best measure against corrosion.

8.2.2 Wave Guide Tube (JMA-9123-7XA/9XA)

Attention



- **Install wave guide tubes without any clearance. Leaving a clearance may cause water leakage or corrosion later.**

8.2.3 Coaxial Cable (JMA-9133-SA)

The coaxial tube gland of a coaxial cable terminal is fully waterproofed when installed. To prevent a water leakage accident, periodically inspect the coaxial tube gland. In particular, the coaxial tube gland should be repainted every six months.



WARNING

- 
 - Do not apply strong shock to the coaxial cable by striking it with a tool or hammering it. Otherwise, an open circuit failure may result.
- 
 - Do not place anything heavy on the coaxial cable. Otherwise, an open circuit failure may result.
- 
 - Do not twist or pull the coaxial cable.

For details, refer to the coaxial cable installation procedure for S-band radars.

8.2.4 Transmitter Receiver Unit (NTG-3225/3230)

Wipe dust off the transmitter and receiver with a dry cloth or feather duster.

8.2.5 Display Unit (NCD-4990)



WARNING

- 
 - When cleaning the screen, do not wipe it too strongly with a dry cloth. Also, do not use gasoline or thinner to clean the screen. Otherwise the screen surface may be damaged

Dust accumulated on the screen will reduce clarity and darken the video. For cleaning it, wipe it with a piece of soft cloth (flannel or cotton).

Do not wipe it strongly with a piece of dry cloth nor use gasoline or thinner.

8.3 PERFORMANCE CHECK

Make operational check on the radar equipment regularly and if any problem is found, investigate it immediately. Pay special attention to the high voltage sections in checking and take full care that no trouble is caused by any error or carelessness in measurement. Take note of the results of checking, which can be used effectively in the next check work.

Operational check shall be made in accordance with Table 8-1 Function Check List in the order as specified in it.

Table8-1 : Performance Check List

Equipment	Item to be checked	Criteria	Remarks
Transmitter Receiver Unit	Tuning LED of Receiver	The LED is lighting during operation	48NM range
Display Unit	Video and echoes on the screen Sensitivity LCD brilliance can be controlled correctly Various markers Various numerical indications Lighting	Can be correctly controlled	
	Memory	See the Section [1] "Memory Test"	
	Communications Lines	See the Section [3] "Check of Communication Lines (Line Test)"	
	Power Supply, Backup Battery	See the Section [4] "Supply Voltage"	
	Monitor	See the Section 8.3.1.2 "Monitor Test"	
	Operation Unit	See the Section 8.3.1.3 "Operation Unit Test (Keyboard Test)"	
	System Alarm Log Display	See the Section 8.3.1.5 "System Alarm Log display"	
	System Information Display	See the Section 8.3.1.6 "System Information"	
	Magnetron current	See the Section 8.3.1.7 "Magnetron Current"	
	Target Tracking	See the Section 5.2.7 "Operation Test (TT Test Menu)"	
Scanner Unit	Signals from the Scanner Unit	See the Section [2] "TXRX Test"	
	Performance Monitor	See the Section 8.3.1.4 "Check of the Performance Monitor (MON Display)"	

8.3.1 Check Performance on Test Menu

The radar operating state can be checked by opening the Test Menu.

Procedures

- 1) Perform the following menu open procedure to open the Test Menu.

Main

→ 9. Test Menu

- 2) Select the items to be checked.

1. Self Test	8.3.1.1Self-diagnosis function (Self Test)
2. Monitor Test	8.3.1.2Monitor Test
3. Keyboard Test	8.3.1.3Operation Unit Test (Keyboard Test)
4. MON Display	8.3.1.4Check of the Performance Monitor (MON Display)
5. System Alarm Log	8.3.1.5System Alarm Log display
6. System Information	8.3.1.6System Information
Magnetron Current	8.3.1.7Magnetron Current

The list of check items will appear.

8.3.1.1 Self-diagnosis function (Self Test)

Check of memory, scanner unit, and communications Lines

1. Memory Test	[1]Memory Test
2. TXRX Test	[2]TXRX Test
3. Line Test	[3]Check of Communication Lines (Line Test)
4. Supply Voltage	[4]Supply Voltage

[1] Memory Test

Checks for the performance of built-in memory.

1. SDRAM	SDRAM Check
2. SRAM	SRAM Check
3. FLASH ROM	FLASH ROM Check
4. GRAPHIC	GRAPHIC Check

When no abnormality is found, OK is displayed. When an abnormality is found, NG is displayed.

[2] TXRX Test

Checks for signals from the scanner.

Safety Switch	Scanner's safety switch check
AZI Pulse	Scanner rotation signal check
HL Pulse	Heading line signal check
MH Current	Check on the load current of high voltage in the modulator
Trigger	Radar trigger signal check
Video	Radar video check

When no abnormality is found, OK is displayed. When an abnormality is found, NG is displayed.

In standby, ** will appear.

[3] Check of Communication Lines (Line Test)

Check the status of communications with options.

TXRX	Check on connection with the transmitter-receiver
SIG. PROC	Check on connection with the signal processing circuit
TT	Check on connection with the target tracking unit
GYRO I/F	Check on connection with the GYRO I/F unit
ISW	Check on connection with the interswitch

When no abnormality is found, OK is displayed. When an abnormality is found, NG is displayed.

The status display field of equipment not connected is left blank.

[4] Supply Voltage

Check the voltage of internal power supply.

Item	Normal value
12V	11.4 to 12.6V
5V	4.75 to 5.25V
3.3V	3.14 to 3.46V
Battery	2.5V or more

8.3.1.2 Monitor Test

Checks for the display.

The test pattern will be shown on the display.

- 1. Pattern1 : All colors are filled with white.
- 2. Pattern2 : A white box is displayed on the black background of 1280 × 1024dot.
- 3. Pattern3 : Displays rectangle X 2, circle X 2, and cross-shape X13 (white lines on the black background).
- 4. Pattern4 : Displays “H” of 9 dots X 9 dots on the entire screen (white character on the black background).
- 5. Pattern5 : Gray scale display (16 levels)
- 6. Pattern6 : Displays a color bar.
- 7. Pattern7 : Displays the VDR test pattern.
- 8. Pattern8 : Displays the specified color.

To return to the normal display, press any key.

If errors occur in the monitor, no test pattern will appear.

8.3.1.3 Operation Unit Test (Keyboard Test)

Checks for the controls and switches of the operation panel.

- 1. Key Test [1]Key Test
- 2. Buzzer Test [2]Buzzer Test
- 3. Light Test [3]Light Test

[1] Key Test

Checks for the controls and switches of the operation panel.

Each key on the operation panel on the display is shown in reverse video at the same time the key is pressed, and the name of the pressed key is displayed.

[2] Buzzer Test

Checks for the operation panel buzzer.

The buzzer will sound. The buzzer automatically stops after it sounds for a specified length of time.

[3] Light Test

Checks for the control panel light.

The brightness of the operation panel is gradually intensified at four levels.

8.3.1.4 Check of the Performance Monitor (MON Display)

Displays the performance monitor status.

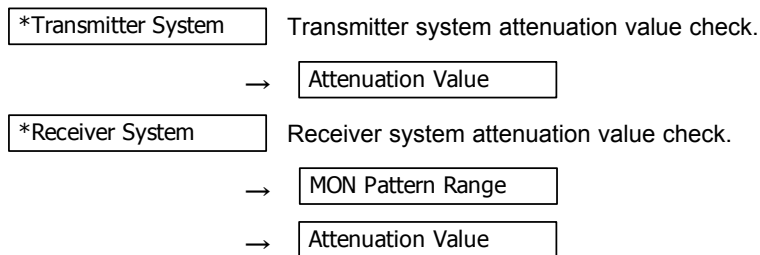

Procedures

- 1) Turn the [VRM] dial to make adjustments so that the farthest point of the performance monitor pattern.

The Attenuation Value of *Receiver System is displayed.

8.3.1.5 System Alarm Log display

Displays previously occurred system errors with the dates and times when they occurred.

The current error is displayed at the lower right of the radar display. For details, refer to Section 9.1.1 "List of Alarms and other Indications".

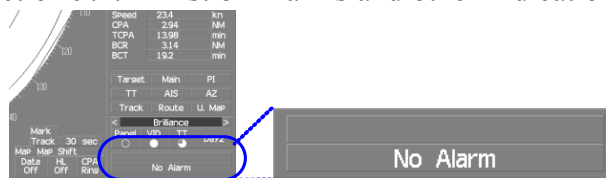

The Error log display button (page2-31 Alarm) is clicked, in the same way as that one.

To erase the alarm logs, press the All Clear button in the log display window.

8.3.1.6 System Information

Displays the current system information.

Indicator	Processor software version information
TXRX	Scanner software version information
System No.	System number
TX Time	Total magnetron transmitting time (Total time during which radar was transmitted)
→	X-Band
→	S-Band
Motor Time	Total operating time (Total power-on time)
TXRX Total Time	Total operating time of the scanner unit (Total power-on time of the scanner unit)
Total Time	Total operating time of the display unit (Total power-on time of the display unit)

8.3.1.7 Magnetron Current

↗ Displays the Magnetron Current bar indicating the magnetron current to check.

When a 48 NM range is set, the magnetron current is normal if the Magnetron Current bar reads the value below.

10kW : 4 to 6 scale marks

25/30kW : 6 to 9 scale marks

8.4

REPLACEMENT OF MAJOR PARTS

The system includes parts that need periodic replacement. The parts should be replaced as scheduled. Use of parts over their service life can cause a system failure.



CAUTION



- Turn off the main power source before replacing parts. Otherwise, an electric shock or trouble may be caused.



- Before replacing the magnetron, turn off the main power source and wait for 5 minutes or more until the high voltage circuits are discharged. Otherwise, an electric shock may be caused.



- Take off your wrist watch when bringing your hands close to the magnetron. Otherwise, your watch may be damaged because the magnetron is a strong magnet.



- Two or more persons shall replace the liquid crystal monitor. If only one person does this work, he may drop the LCD, resulting in injury.



- Even after the main power source is turned off, some high voltages remain for a while. Do not contact the inverter circuit in the LCD with bare hands. Otherwise, an electric shock may be caused.

8.4.1 Parts Required for Periodic Replacement

Here are parts required for periodic replacement

Part name	Interval	Radar model	Part type	Part code
1. Magnetron	4,000 hours	JMA-9110-6XA/6XAH	5VMAA00102	5VMAA00102
		JMA-9122-6XA/9XA/6XAH	5VMAA00106	5VMAA00106
		JMA-9123-7XA/9XA		
		JMA-9132-SA JMA-9133-SA	5VMAA00104	5VMAA00104
2. Motor	10,000 hours	JMA-9110-6XA/6XAH	7BDRD0048	7BDRD0048
		JMA-9122-6XA/9XA	MDBW10822	MDBW10822
		JMA-9123-7XA/9XA		
		JMA-9122-6XAH	7BDRD0045A	7BDRD0045A
		JMA-9132-SA JMA-9133-SA	MDBW10823	MDBW10823
3. Fan (Scanner Unit)	20,000 hours	JMA-9110-6XA/6XAH	7BFRD0002	7BFRD0002
		JMA-9122-6XA/9XA/6XAH		
		JMA-9132-SA		
4. LCD PANEL	50,000 hours		7WSRD0002A	7WSRD0002A
5. Fan				
(Radar Process Circuit)	20,000 hours		109R0612S4D13	5BFAB00588
(Power Supply)	20,000 hours		H-7BFRD0006	7BFRD0006
7. Backup battery	5 years		5ZBCJ00012	5ZBCJ00012

8.4.2 Replacement of magnetron



Replacement of magnetron must be made by specialized service personnel.

For details, refer to Service Manual.

When mounting a new magnetron, do not touch the magnet with a screwdriver or put it on an iron plate. After replacement, connect the lead wire correctly.

Handling of Magnetron under Long-Time Storage

The magnetron that has been kept in storage for a long time may cause sparks and operate unstably when its operation is started. Perform the aging in the following procedures:

- 1) **Warm up the cathode for a longer time than usually. (20 to 30 minutes in the STBY state.)**
- 2) **Start the operation from the short pulse range and shift it gradually to the longer pulse ranges. If the operation becomes unstable during this process, return it to the standby mode immediately. Keep the state for 5 to 10 minutes until the operation is restarted.**

8.4.2.1 Scanner Unit NKE-1130

[Required tools]

- A Phillips screwdriver for 4 mm screw
- A Phillips screwdriver for 6 mm screw
- A wrench (width across flats 13 mm, for M8 screws)

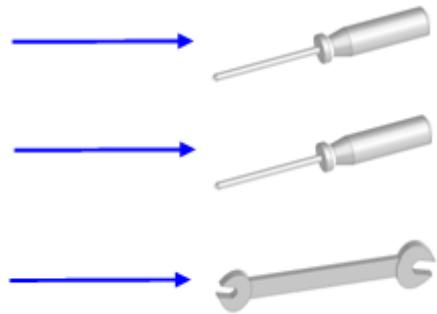

[Replacement procedure]

- 1) *Before starting part replacement work, turn off the safety switch of the scanner unit. The safety switch is located on the rear (stern) side. Remove the cover and turn off (to the lower side) the safety switch.*

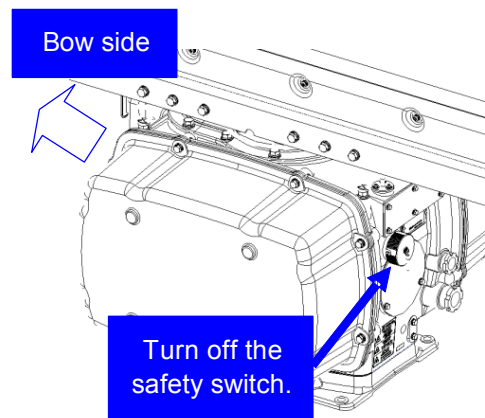

- 2) *Remove the pedestal cover. Make sure that there is no foreign matter or dust adhered to the gasket when you put the cover on.*

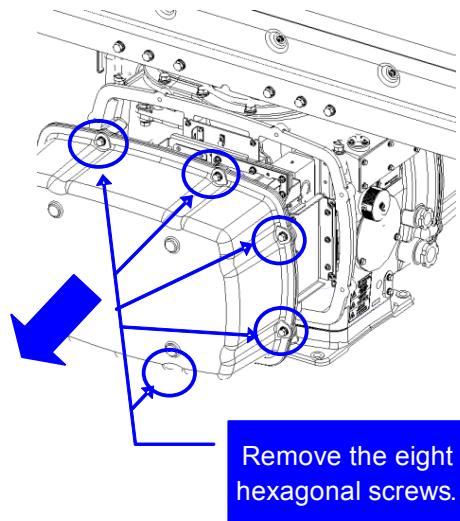

Removing the port side cover

- 3) Remove the cover on the left (port) side and check that there is no remaining electric charge in the modulation high-voltage circuit board.

Remove the two screws (M4) holding the magnetron cables (both yellow and green).

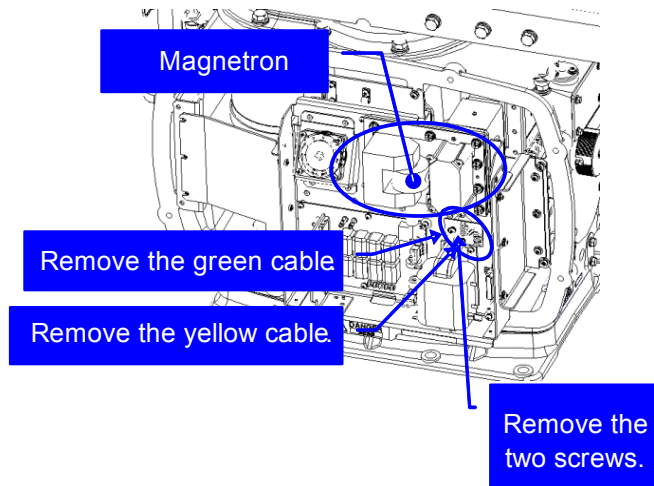

- 4) Remove the eight screws (M6) to remove the fixture holding the magnetron. The screws cannot be removed from the fixture, so loosen the all eight screws and remove the magnetron together with the fixture.

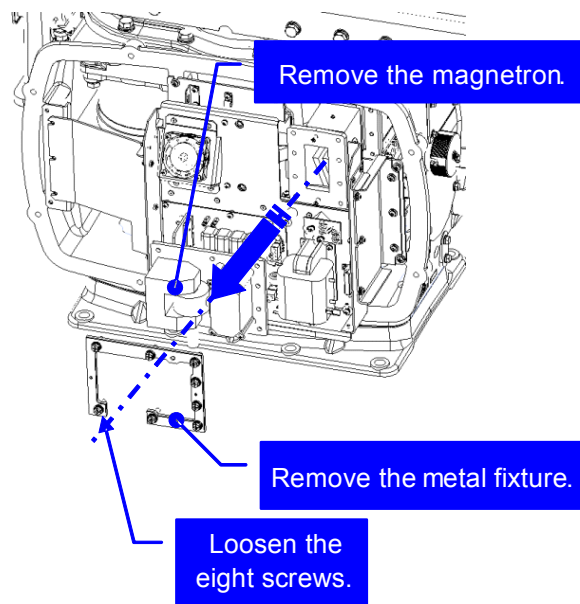

CAUTION
The magnetron is held by a hook, but be careful not to let it fall.

CAUTION
Use a non-magnetic screwdriver. If the magnetron comes into contact with any metal (tool), its performance may deteriorate.

- 5) Install the new magnetron together with the fixture and tighten the screws to hold the cables.

Follow the removal procedure in the reverse order.

Do not forget to tighten the screws and connect the cables.

[Operation check]

After you have completed the replacement work, follow the procedure below to check the operation.

- 1) Turn on the power supply for the radar. Allow sufficient time for the radar to be preheated (about 20 to 30 minutes / bring the radar unit to STBY mode).
- 2) Start emitting radio waves from the short pulse range and gradually change the emissions to the long pulse range. Open the service engineer menu to perform tuning adjustment.

If operation becomes unstable, bring the radar unit back to STBY mode and restart emission after allowing for an interval of 5 to 10 minutes.

- 3) Emit radio waves in long pulse range mode for about 15 minutes and reopen the service engineer menu to perform tuning adjustment.

Adjust the setting in the service engineer menu until the tuning indication bar on the display unit reaches the 8th calibration marking.

Check in the service engineer menu that the magnetron current is between the 6th and 9th calibration markings.

- 4) Finally, initialize the transmission time in the service engineer menu.

8.4.2.2 Scanner Unit NKE-2254, NKE-1125

[Required tools]

- A Phillips screwdriver for 4 mm screw
- A Phillips screwdriver for 6 mm screw
- A wrench (width across flats 13 mm, for M8 screws)

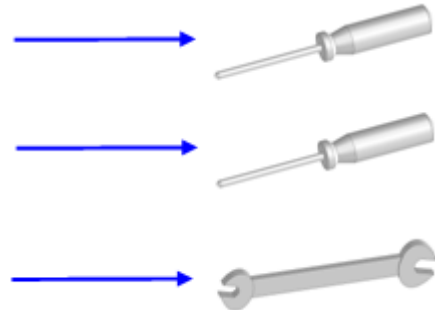

[Replacement procedure]

- 1) Before starting part replacement work, turn off the safety switch of the scanner unit.

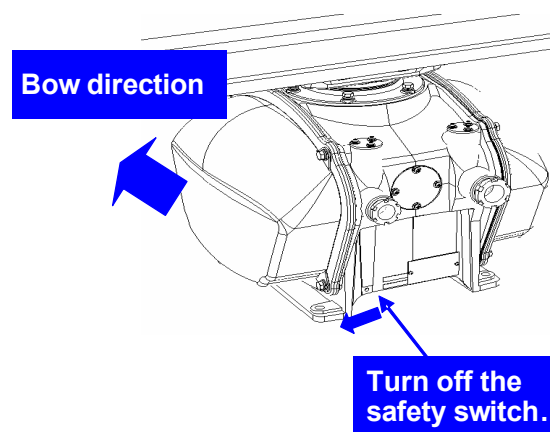

- 2) *Loosen the hexagonal bolts (4) and remove the pedestal cover.*

Make sure that there is no foreign matter or dust adhered to the gasket when you put the cover on.

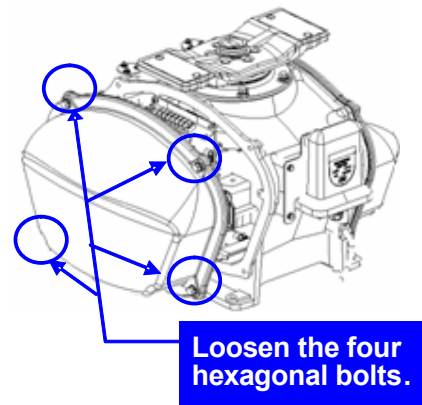

When the starboard side cover is removed

- 3) *Loosen the screws (four M4 screws) to remove the magnetron cover.*

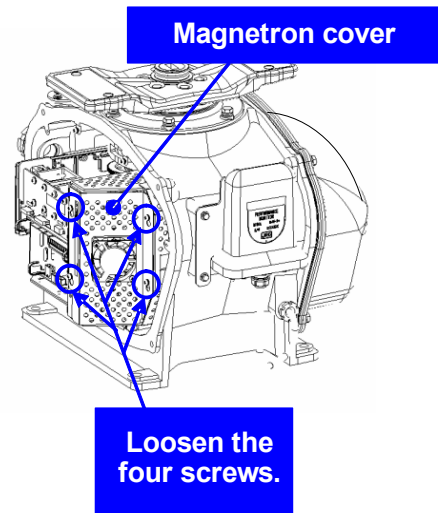

- 4) *Make sure there is no charge remaining in the modulation high-voltage circuit board, and then remove the screws (two M4 screws) holding the magnetron cables (yellow and green) in place.*

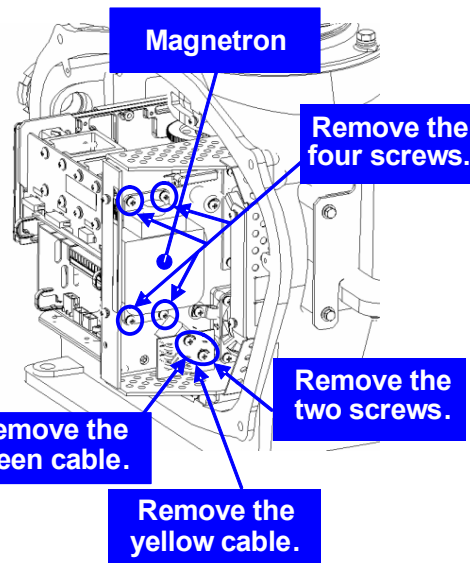

- 5) *Remove the screws (four M4 screws) holding the magnetron in place, then replace the magnetron after cutting the leads (yellow and green) for the replacement magnetron to an appropriate length.*



CAUTION

Use a non-magnetic screwdriver. If the magnetron comes into contact with any metal (tool), its performance may deteriorate.

- 6) *After having replaced the magnetron, reassemble the unit by following the disassembly procedure in the reverse order.*

Do not forget to tighten the bolts and screws, and do not forget to reconnect the cables.



CAUTION

Extreme care should be taken to connect the leads (yellow and green) to the magnetron for prevention of contact with other parts or the casing. Contact may cause them to discharge.

[Operation check]

After you have completed the replacement work, follow the procedure below to check the operation.

- 1) *Turn on the power supply for the radar. Allow sufficient time for the radar to be preheated (about 20 to 30 minutes / bring the radar unit to STBY mode).*
- 2) *Start emitting radio waves from the short pulse range and gradually change the emissions to the long pulse range. Open the service engineer menu to perform tuning adjustment.*

If operation becomes unstable, bring the radar unit back to STBY mode and restart emission after allowing for an interval of 5 to 10 minutes.

- 3) *Emit radio waves in long pulse range mode for about 15 minutes and reopen the service engineer menu to perform tuning adjustment.*

Adjust the setting in the service engineer menu until the tuning indication bar on the display unit reaches the 8th calibration marking.

Check in the service engineer menu that the magnetron current is between the 6th and 9th calibration markings.

- 4) *Finally, initialize the transmission time in the service engineer menu.*

8.4.2.3 Scanner Unit NKE-2103

[Required tools]

- 
- A Phillips screwdriver for 6 mm screw
- A wrench (width across flats 13 mm, for M8 screws)

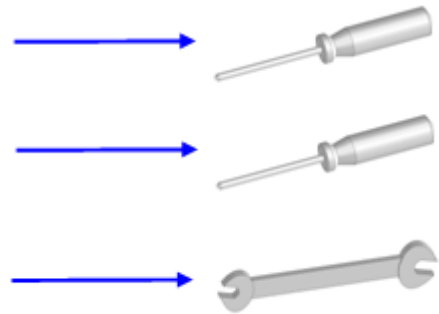

- 1) *Before starting part replacement work, turn off the safety switch on the bottom of the scanner unit.*

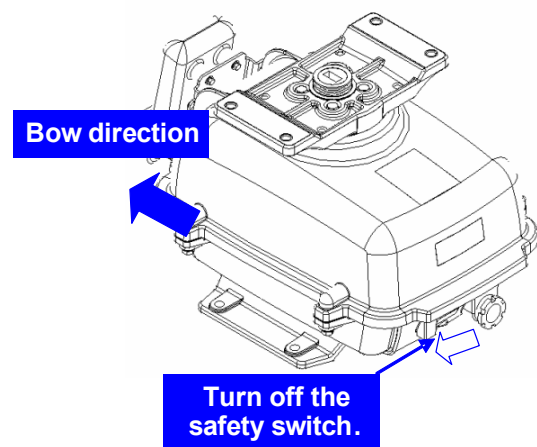

- 2) *Loosen the hexagonal bolts (four bolts) and open the upper cover until the stopper of the stay operates.*

 **CAUTION.**
When closing the upper cover, release the stay stopper and then tighten the cover.

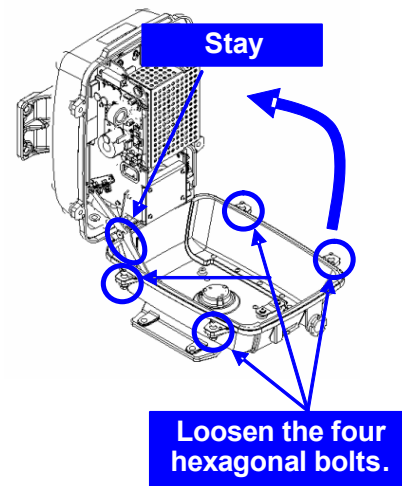

- 1) Loosen the screws (four M4 screws), remove the transmitter-receiver unit cover, and remove the cables connected to the transmitter-receiver unit (ten cables). Slide the cover of the transmitter-receiver unit to remove it.

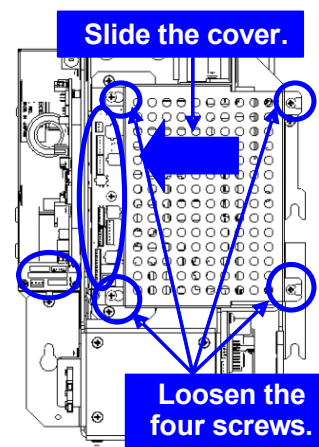

- 2) Loosen the bolts (five M5 bolts) and remove the transmitter-receiver unit. Slide the transmitter-receiver unit upward to remove it.

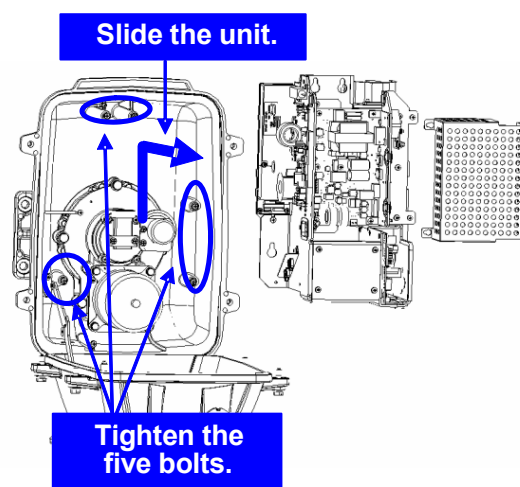

- 3) Remove the screws (six M4 screws) holding the magnetron in place and replace the magnetron.



CAUTION

Use a non-magnetic screwdriver. If the magnetron comes into contact with any metal (tool), its performance may deteriorate.

- 4) Cut the leads (yellow and green) for the replacement magnetron to an appropriate length, then tighten the screws and fix the cables in place.

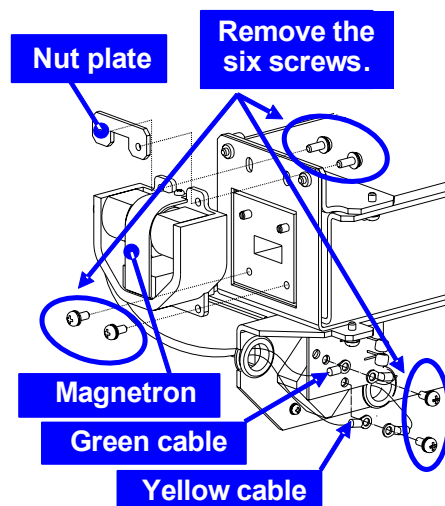

After having replaced the magnetron, reassemble the unit by following the disassembly procedure in the reverse order.



CAUTION

Do not forget to tighten the bolts and screws, and do not forget to reconnect the cables.



CAUTION

Extreme care should be taken to connect the leads (yellow and green) to the magnetron for prevention of contact with other parts or the casing.

[Operation check]

After you have completed the replacement work, follow the procedure below to check the operation.

- 1) *Turn on the power supply for the radar. Allow sufficient time for the radar to be preheated (about 20 to 30 minutes / bring the radar unit to STBY mode).*
- 2) *Start emitting radio waves from the short pulse range and gradually change the emissions to the long pulse range. Open the service engineer menu to perform tuning adjustment.*

If operation becomes unstable, bring the radar unit back to STBY mode and restart emission after allowing for an interval of 5 to 10 minutes.

- 3) *Emit radio waves in long pulse range mode for about 15 minutes and reopen the service engineer menu to perform tuning adjustment.*

Adjust the setting in the service engineer menu until the tuning indication bar on the display unit reaches the 8th calibration marking.

Check in the service engineer menu that the magnetron current is between the 4th and 6th calibration markings.

- 4) *Finally, initialize the transmission time in the service engineer menu.*

8.4.2.4 Transmitter Receiver Unit NTG-3230

[Required tools]

A flatblade screwdriver for 6 mm screws

- A Phillips screwdriver for 4 mm screw
- A Phillips screwdriver for 6 mm screw

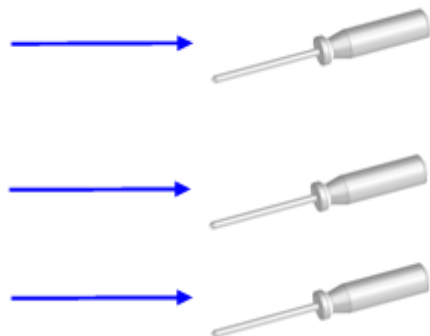

[Replacement procedure]

- 1) *Loosen the four screws and remove the cover.*

The screws are slotted captive screws. Use a flatblade screwdriver.

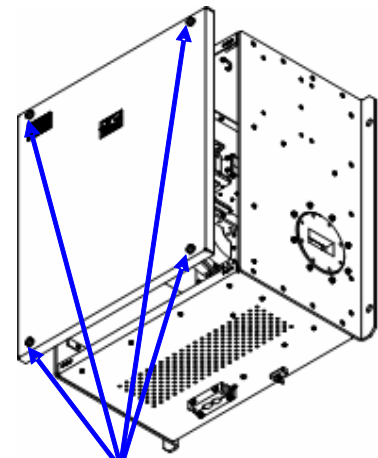

Remove the four screws.

- 2) *Remove the screws (six M4 screws) and slide the modulator cover to the right to remove it.*

Modulator cover

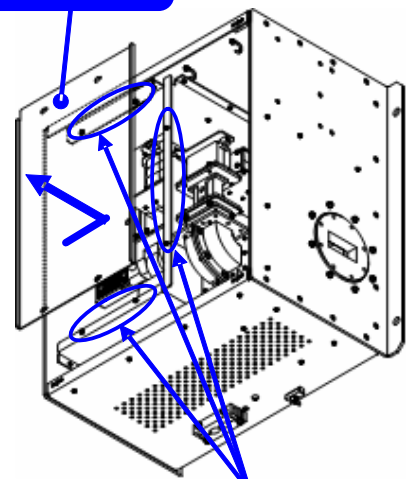

Loosen the six screws.

- 3) Remove the screws holding the cables (two M4 screws) and the bolts holding the magnetron (eight M6 screws) and remove the metal fitting and the magnetron.



CAUTION

Use a non-magnetic screwdriver. If the magnetron comes into contact with any metal (tool), its performance may deteriorate.

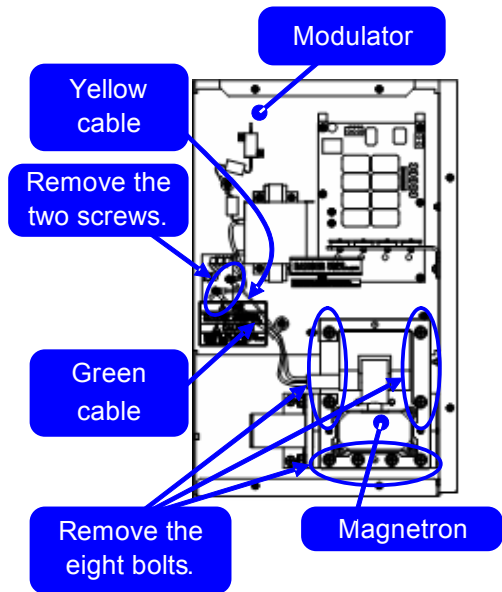

- 4) Be careful to attach the colored cables (yellow and green) to the correct connections on the replacement magnetron.

After having replaced the magnetron, reassemble the unit by following the disassembly procedure in the reverse order.



CAUTION

Do not forget to tighten the bolts and screws, and do not forget to reconnect the cables.

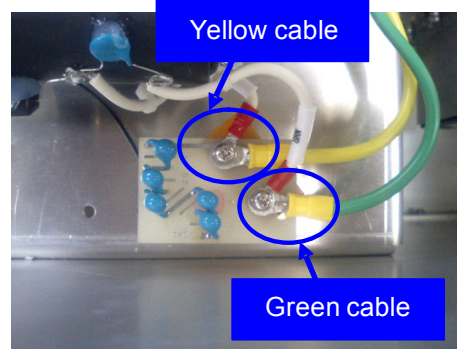

[Operation check]

After you have completed the replacement work, follow the procedure below to check the operation.

- 1) Turn on the power supply for the radar. Allow sufficient time for the radar to be preheated (about 20 to 30 minutes / bring the radar unit to STBY mode).
- 2) Start emitting radio waves from the short pulse range and gradually change the emissions to the long pulse range. Open the service engineer menu to perform tuning adjustment.
If operation becomes unstable, bring the radar unit back to STBY mode and restart emission after allowing for an interval of 5 to 10 minutes.
- 3) Emit radio waves in long pulse range mode for about 15 minutes and reopen the service engineer menu to perform tuning adjustment.

Adjust the setting in the service engineer menu until the tuning indication bar on the display unit reaches the 8th calibration marking.

Check in the service engineer menu that the magnetron current is between the 6th and 9th calibration markings.

- 4) *Finally, initialize the transmission time in the service engineer menu.*

8.4.2.5 Transmitter Receiver Unit NTG-3225

[Required tools]

A flatblade screwdriver for 6 mm screws

- A Phillips screwdriver for 4 mm screw

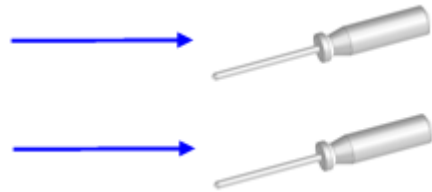

[Replacement procedure]

- 1) *Loosen the four screws and remove the cover.*

The screws are slotted captive screws. Use a flatblade screwdriver.

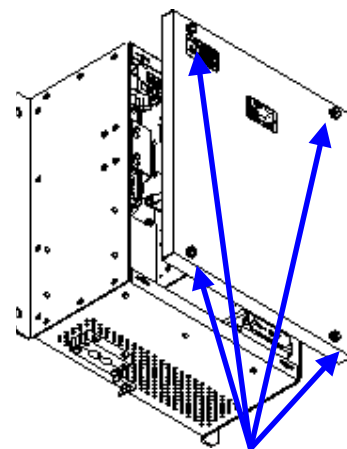

Loosen the four screws.

- 2) Loosen the upset head bolt (one M4 bolt), and slide the tightening metal fitting, located between the modulator and the circulator, to remove it.

The magnetron is installed within the modulator.

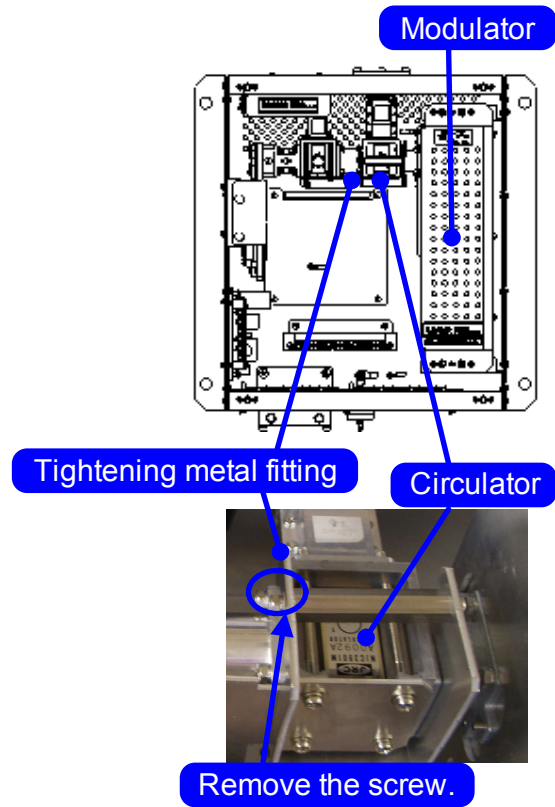

- 3) Loosen the inside screws of the modulator (four M4 screws).

Removing the outside screws makes it possible to slide the modulator.

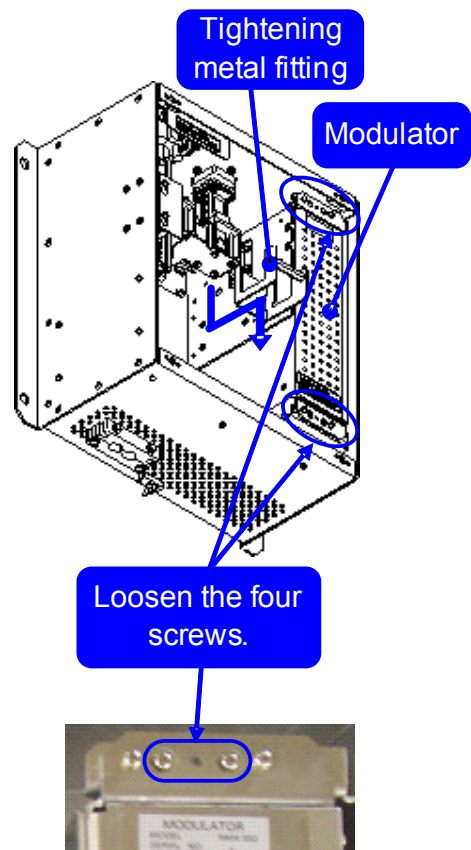

- 4) Remove the cables connected to the modulator and the screws on the outside of the modulator (four M4 screws) and slide the modulator to the right to remove it.

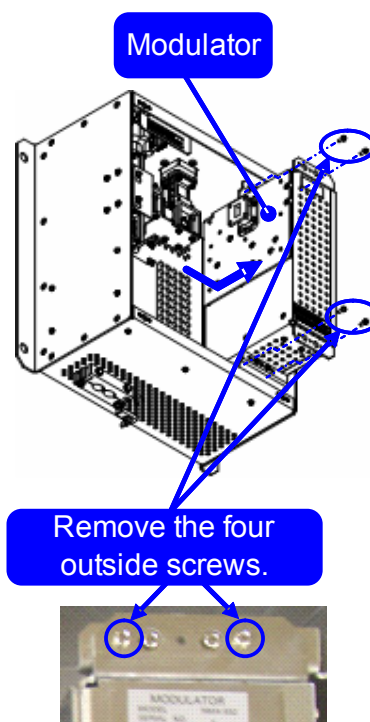

- 5) Remove the screws (six M4 screws) and take off the modulator cover.

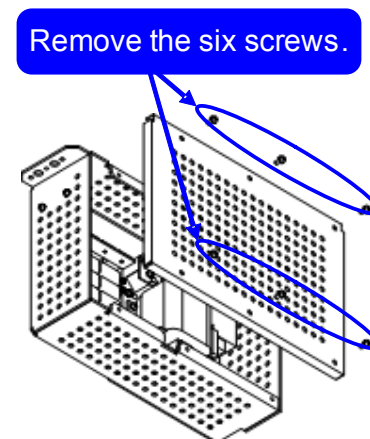

- 6) Remove the screws holding the cables (two M4 screws) and the screws holding the magnetron (four M4 screws) and remove the metal fitting and the magnetron.

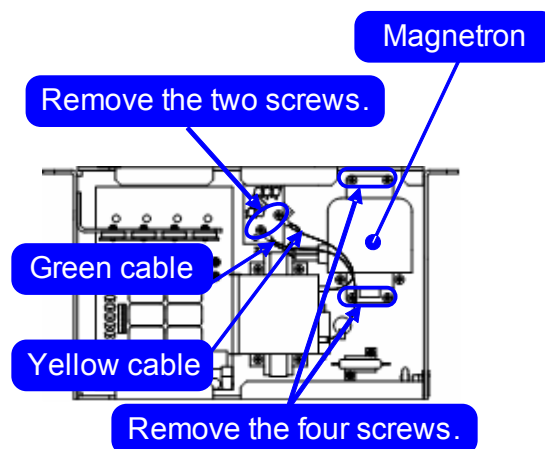

CAUTION

Use a non-magnetic screwdriver. If the magnetron comes into contact with any metal (tool), its performance may deteriorate.

- 7) *Be careful to attach the colored cables (yellow and green) to the correct connections on the replacement magnetron.*

After having replaced the magnetron, reassemble the unit by following the disassembly procedure in the reverse order.

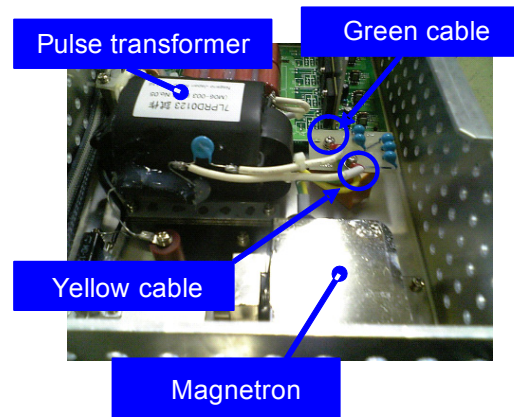

CAUTION

Do not forget to tighten the bolts and screws, and do not forget to reconnect the cables.

[Operation check]

After you have completed the replacement work, follow the procedure below to check the operation.

- 1) *Turn on the power supply for the radar. Allow sufficient time for the radar to be preheated (about 20 to 30 minutes / bring the radar unit to STBY mode).*
- 2) *Start emitting radio waves from the short pulse range and gradually change the emissions to the long pulse range. Open the service engineer menu to perform tuning adjustment.*

If operation becomes unstable, bring the radar unit back to STBY mode and restart emission after allowing for an interval of 5 to 10 minutes.

- 3) *Emit radio waves in long pulse range mode for about 15 minutes and reopen the service engineer menu to perform tuning adjustment.*

Adjust the setting in the service engineer menu until the tuning indication bar on the display unit reaches the 8th calibration marking.

Check in the service engineer menu that the magnetron current is between the 6th and 9th calibration markings.

- 4) *Finally, initialize the transmission time in the service engineer menu.*

8.4.3 Replacement of Motor



Replacement of motor must be made by specialized service personnel.

For details, refer to Service Manual.

8.4.3.1 Scanner Unit NKE-1139/1130

[Required tools]

- A wrench (width across flats 17 mm, for M10 screws)
- A Phillips screwdriver for 4 mm screw
- Tools for removing the cover from the scanner unit.(Refer to the 8.4.2.1)

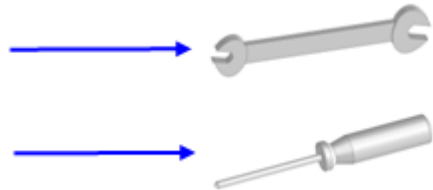

[Replacement procedure]

- 1) Remove the cover on the right (starboard) side (see 8.4.2.1) and loosen the four screws (M4) to remove the driver unit, which has the motor driver circuit board on its back side.

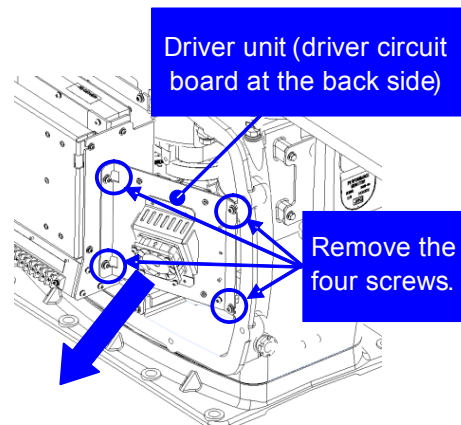

Disconnect the cables connecting the motor to the motor driver circuit board.

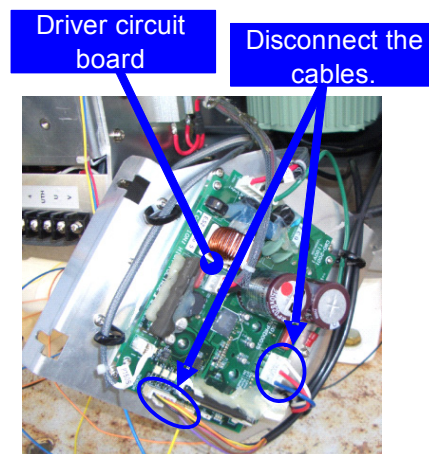

- 2) Remove the cover on the left (port) side and remove the five screws (M5) to remove the fixture.

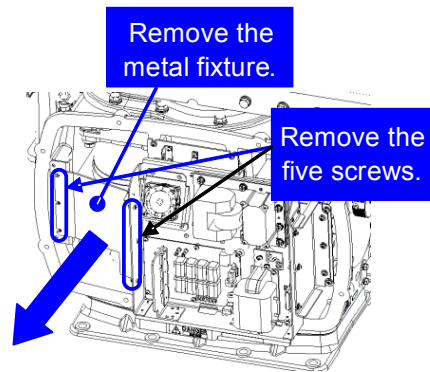

- 3) Remove the four hexagonal screws (M10x40, SW10, and W10) that hold the motor from both the right and left sides to remove the motor.

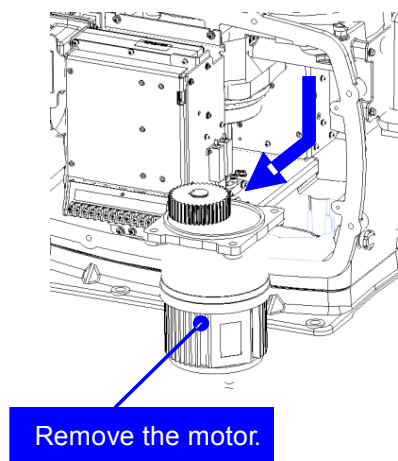
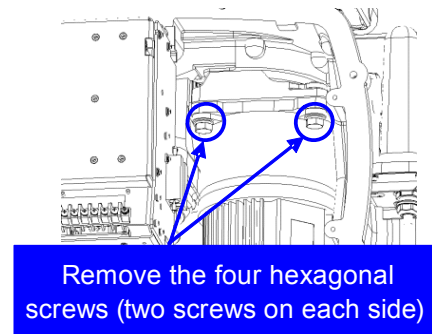

- 4) Apply grease to the gear wheel of the new motor.
- 5) Install the new motor in the scanner unit and secure it using the hexagonal screws. Tighten the screws with the specified torque (380 kgf-cm).
- 6) After replacing the motor, assemble the unit in the reverse order of the disassembly procedure.

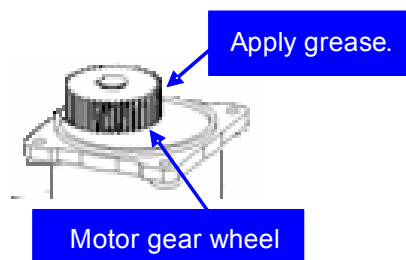

CAUTION
Do not forget to tighten the screws and connect the cables.

[Operation check]

After you have completed the replacement work, follow the procedure below to check the operation.

- 1) Turn on the radar power supply. After the countdown is completed, start emission and check that the radar image appears without error. Check that you do not hear any unusual sound when the motor starts, rotates, and stops.
- 2) Open the service engineer menu to initialize the motor rotation time.

8.4.3.2 Scanner Unit NKE-1125/2254

[Required tools]

- Single-ended wrench (width across flats 17 mm for M8 bolts)
- Tools for removing the cover from the scanner unit.(Refer to the 8.4.2.2)



[Replacement procedure]

- 1) Remove the cover on the left (port) side (see Section 8.4.2.2) and remove the cables connected to the motor driver circuit board.
- 2) Remove the hexagonal bolts (four M8 bolts) and remove the motor.

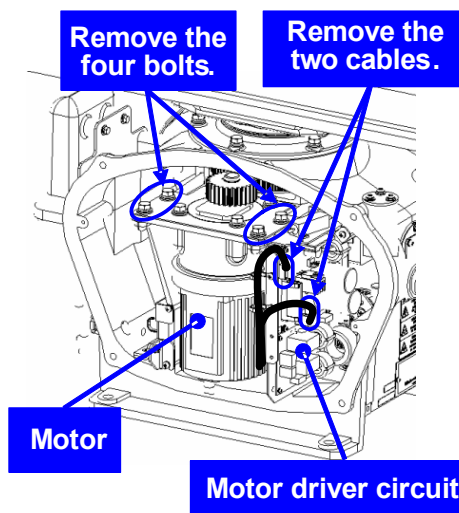

- 3) Remove the hexagonal bolts (four M8 bolts) and remove the installation plate from the motor.

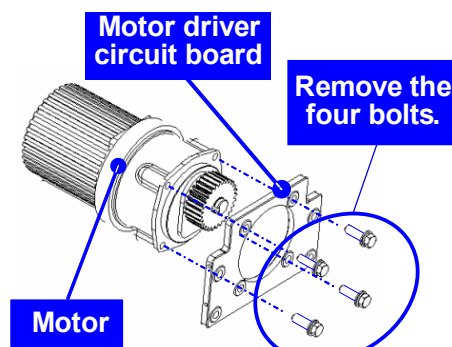

4) Attach the installation plate to the replacement motor. Do not forget to tighten the hexagonal bolts to an appropriate torque (210 kgf-cm) so they are free of looseness.

5) Install the motor into the scanner unit. Press the motor against the protrusions of the arm fixed to the motor on which the arm extends through the wall of the casing, adjust it to minimize backlash, and fix it in place.

Do not forget to tighten the hexagonal bolts, to an appropriate torque (140 kgf-cm) so they are free of looseness.

6) After having installed the motor, grease the gear wheel.

7) After having replaced the motor, reassemble the unit by following the disassembly procedure in the reverse order.

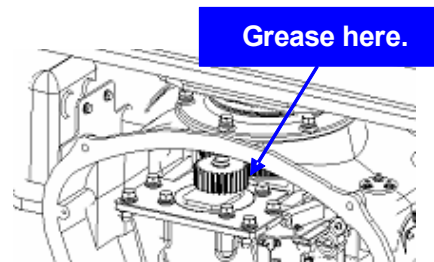
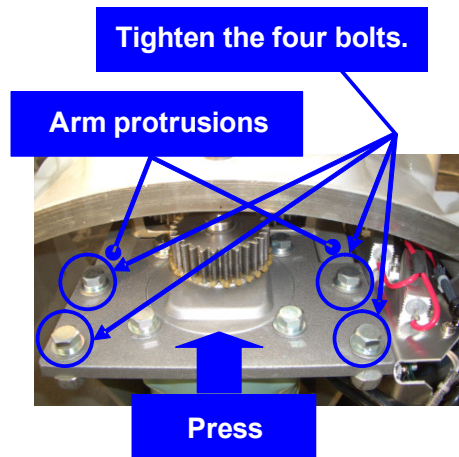

CAUTION

Do not forget to tighten the bolts and screws, and do not forget to reconnect the cables.

8)

8.4.3.3 Scanner Unit NKE-2103

[Required tools]

- A Phillips screwdriver for 4 mm screw
- A Phillips screwdriver for 5 mm screw
- Single-ended wrench (width across flats 10 mm for M6 bolts)
- Tools for removing the cover from the scanner unit.(Refer to the 8.4.2.3)

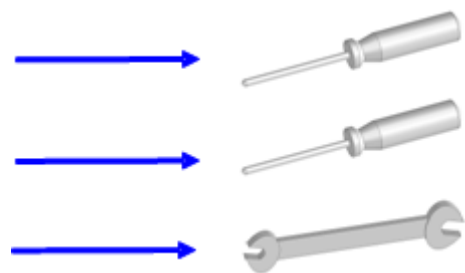

[Replacement procedure]

- 1) *Open the upper cover (see Section 8.4.2.3) to remove the transmitter-receiver unit.*
- 2) *Remove the hexagonal bolts (four M6 bolts) and remove the motor. Grease the gear wheel of the replacement motor and place it in the casing. Do not forget to tighten the hexagonal bolts to an appropriate torque (72 kgf-cm) so they are free of looseness.*

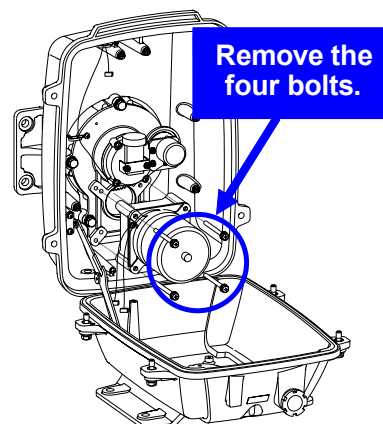

- 3) *After having replaced the motor, reassemble the unit by following the disassembly procedure in the reverse order.*

**CAUTION**

Do not forget to tighten the bolts and screws, and do not forget to reconnect the cables.

**CAUTION**

Clamp the cables so they do not interfere with the rotation of the motor's rotors.

[Operation check]

After you have completed the replacement work, follow the procedure below to check the operation.

- 1) *Turn on the radar and emit radar waves once the countdown is finished, and check that the radar image is correctly displayed. Check that the motor does not make any abnormal sound when it starts to rotate, while it is rotating, or when it stops.*