

Chapter 2 OPERATIONS

2.1 SCREEN DISPLAY

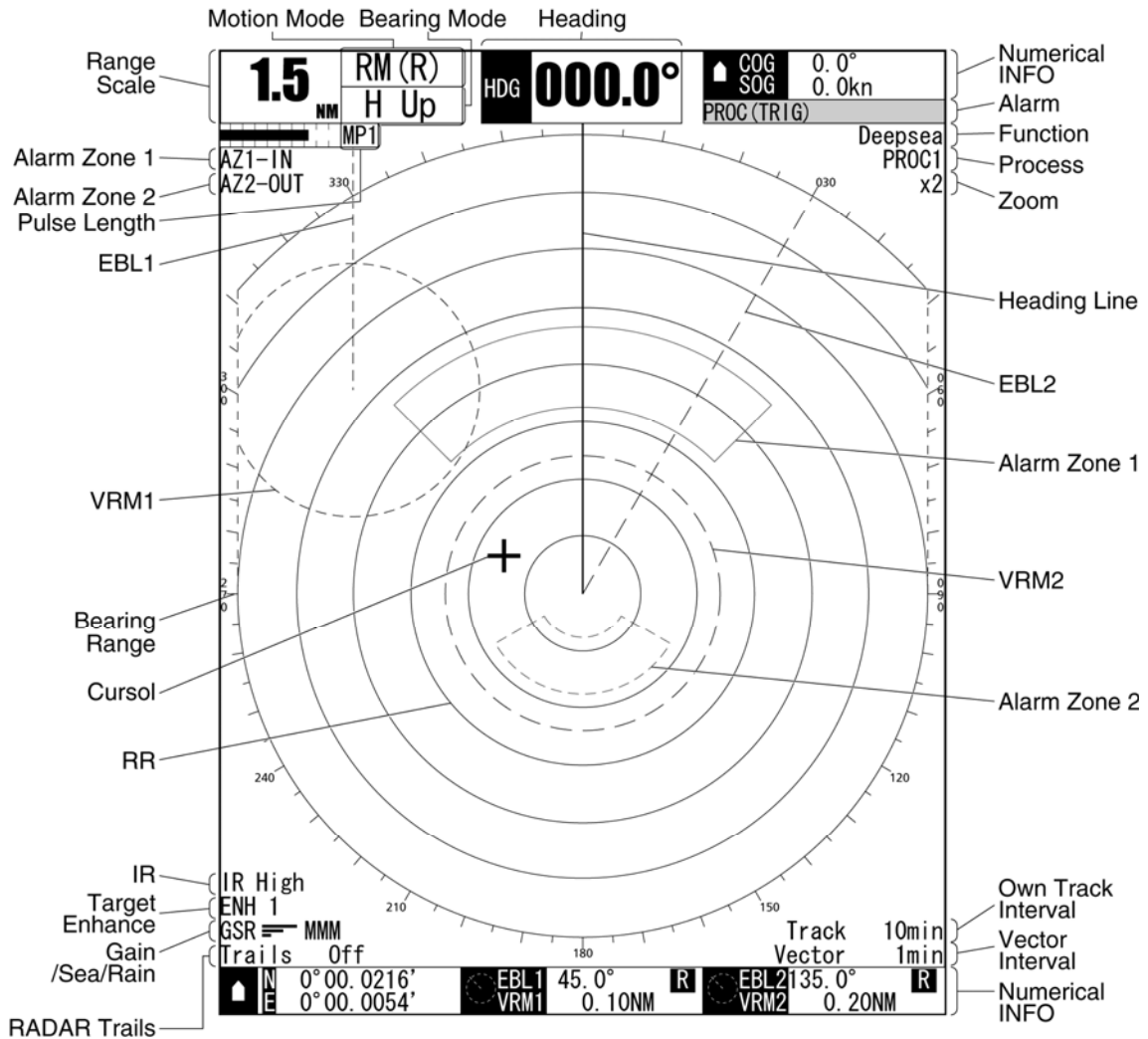

2.2 PANEL

Operate this equipment with the panel of the Display unit.

No.	Key	Description
①	MENU	Press: Opens/closes the menu. Hold down: Opens the code input screen (the Adjust Menu).
②	CLEAR	Press: Cancels menu operations. Returns to upper menu. Stops the alarm sound.
③	ENT	Press: Enters the selected menu item.
	Cursor keys	Press: Selects menu items. Moves the cursor. Hold down: Accelerates cursor movement.
④	GAIN	Press: Performs the user key 1 function. Hold down: Switches the sensitivity between manual and automatic modes. Turn: Adjusts receiving sensitivity.
⑤	SEA	Press: Performs the user key 2 function. Hold down: Switches the sea clutter suppression function between manual and automatic modes. Turn: Removes sea clutter.
⑥	RAIN	Press: Performs the user key 3 function. Hold down: Switches the rain/snow clutter suppression function between manual and automatic modes. Turn: Removes rain/snow clutter.
⑦	RANGE	Press: Switches the range.
⑧	FUNC	Press: Switches function settings. Hold down: Opens the function setting menu.
⑨	BRILL	Press: Changes the display brilliance Hold down: Opens the display color menu.
⑩	MULTI	Press: Opens the soft key menu. Turn: Adjusts the selected mode. Changes the setting values. Selects soft key menu items.
⑪	USB MEMORY	Saves files. Updates the software.
⑫	STBY	Press: Turns on this equipment (when it is turned off). Turns to standby state (when the equipment is transmitting). Press multiple keys: Turns off the equipment when pressed together with the TX/PRF key.
⑬	TX/PRF	Press: Starts transmitting (in standby state) Tunes the repetition frequency (when transmitting). Hold down: Turns off the heading line. (after preheating finished).
⑭	Soft keys	Press: Opens the soft key menu.

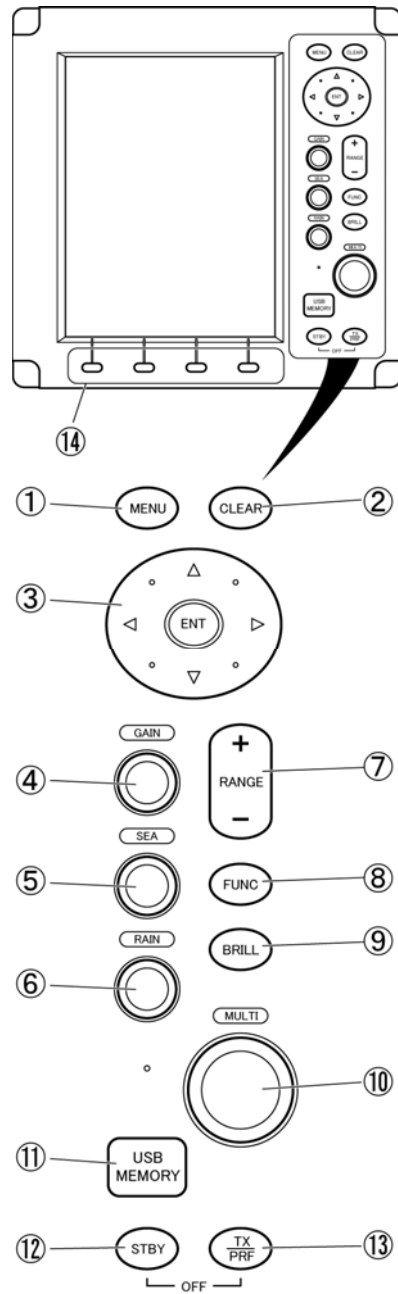

■ Key Operations

- Press: Press a key, then release the key before 2 seconds elapse.
- Hold down: Press a key, and hold down the key for 2 seconds or more.
- Press multiple keys: Press multiple keys simultaneously.
- Turn: Turn a control in clockwise/counterclockwise direction.

2.3 POWER ON/OFF

CAUTION



A malfunction may occur if the power in the ship is instantaneously interrupted during operation of the radar. In this case, the power should be turned on again.

Note:

- Wait for about 2 seconds before turning on the power again.
- Immediately after the radar is installed, at start of the system after it has not been used for a long time, or after the magnetron is replaced, preheat the equipment in the standby state for 20 to 30 minutes before setting it into the transmit state.
- If the preheating time is short, the magnetron causes sparks, resulting in its unstable oscillation.

Start transmission on a short-pulse range and change the range to the longer pulse ranges in turn. If the transmission is unstable in the meantime, immediately place the system back into the standby state and maintain it in the standby state for 5 to 10 minutes before restarting the operation. Repeat these steps until the operation is stabilized.

■ Power On

- 1 Press the [STBY] key on the display unit to turn on the display unit.



The display unit is turned on, and the preheating time screen is displayed.



When the preheating time is over, the preheating time screen disappears.

■ Starting transmission

- 1 Press the [TX/PRF] key.



The radar starts transmission and the antenna starts rotating.

Reference:

The radar cannot start transmission if you press the [TX/PRF] key while the preheating time is displayed.

■ Stopping transmission

- 1 Press the [STBY] key on the display unit.



The radar stops transmission and the antenna stops rotating.

Maintain the standby state if radar observation is restarted in a relatively short time.

Only pressing the [TX/PRF] key starts observation.

■ Power Off

- 1 Press the [STBY] key and the [TX/PRF] key simultaneously.

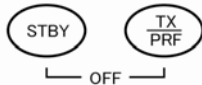

The system is turned off.

 **WARNING**





When conducting maintenance work, make sure to turn off the power and unplug the power connector J1 of the display unit so that the power supply to the equipment is completely cut off. Some equipment components can carry electrical current even after the power switch is turned off, and conducting maintenance work without unplugging the power connector may result in electrocution, equipment failure, or accidents.

2.4 SENSITIVITY ADJUSTMENT

Sensitivity can be adjusted.

Adjust the noise on the display unit to achieve better observation state.

**CAUTION**



If sensitivity is set too high, unnecessary signals such as noises in the receiver and false echoes increase to lower target visibility. At the same time, if sensitivity is set too low, detection of targets such as ships and dangerous objects may be hindered. Therefore, sensitivity must always be set to an optimal level.

■ Noise Adjustment

- 1 Turn the [GAIN] control.



Turn the [GAIN] control clockwise to increase sensitivity.

Turn the [GAIN] control counterclockwise to decrease sensitivity.

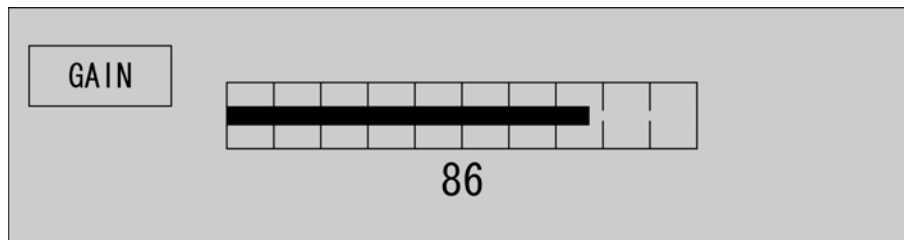

The sensitivity adjustment screen appears when turning the [GAIN] control.

Sensitivity can be adjusted between 0 and 100.

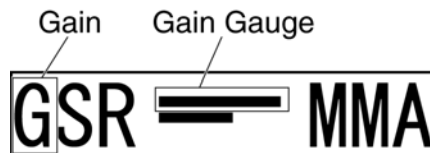

When turning the [GAIN] control, the gain control indication is stretched or shrunk.

● [GAIN] Control

Turning the [GAIN] control clockwise increases receiving sensitivity and extends the radar observation range. If the sensitivity is too high, the receiver noise increases reducing the contrast between the targets and the background video. As a result, the targets become obscure on the radar display. To observe densely crowded targets or short-range targets, turn the [GAIN] control counterclockwise to reduce the sensitivity so that the targets are easy to observe. However, be careful not to overlook important small targets.

■ Switching to Manual/Automatic Mode

- 1 Hold down the [GAIN] control.



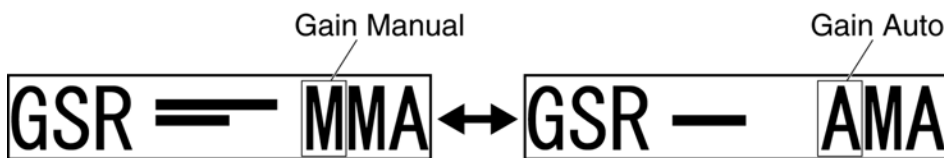

The sensitivity can be switched between manual and automatic modes. The mode is indicated as shown below.



2.5 SEA CLUTTER SUPPRESSION

The sea clutter suppression function suppresses sea clutter returns.

 **CAUTION**



When using the sea clutter suppression function, never set the suppression level too high canceling out all image noises from the sea surface at close range. Detection of not only echoes from waves but also targets such as other ships or dangerous objects will become inhibited.

When using the sea clutter suppression function, make sure to choose the most appropriate image noise suppression level.

■ Manual Sea Clutter Suppression Function

Adjust the sea clutter returns on the display unit to achieve better observation state.

- 1 Turn the [SEA] control.



Turn the [SEA] control clockwise to suppress sea clutter returns.

Turn the [SEA] control counterclockwise to intensify sea clutter returns.

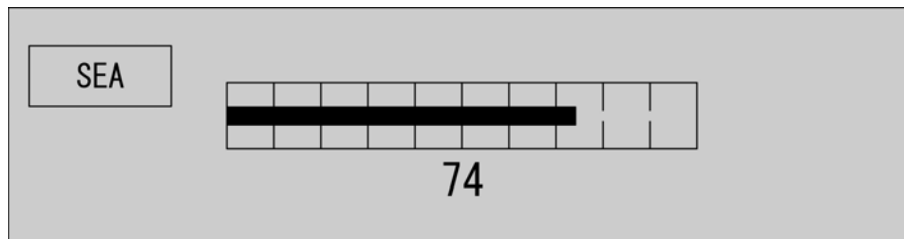

The sea clutter suppression adjustment screen appears when turning the [SEA] control.

Sea clutter suppression can be adjusted between 0 and 100.

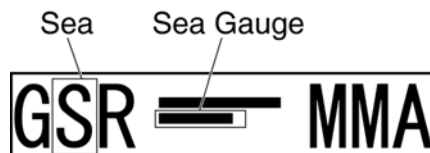

When turning the [SEA] control, the sea clutter control indication is stretched or shrunk.

● [SEA] Control

The sea clutter suppression function suppresses sea clutter returns by decreasing the receiving sensitivity on a short range. Turn the [SEA] control clockwise to heighten the effect of sea clutter suppression. However, be careful that excessive suppression causes low signal-strength targets such as buoys and boats to disappear from the radar display.

■ Automatic Sea Clutter Suppression Function

Sea clutter suppression can be performed in accordance with the level of sea clutter. Use this automatic mode when sea clutter returns vary in direction.

- 1 Hold down the [SEA] control.



Automatic function is selected.

Even when the automatic function is selected, you can manually perform fine adjustments by turning the [SEA] control.

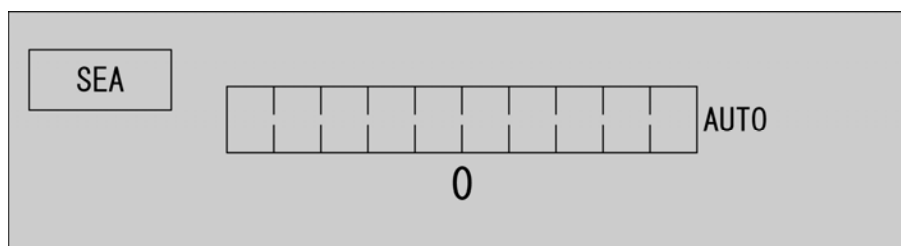

The sea clutter suppression adjustment screen appears when turning the [SEA] control. Sea clutter suppression can be adjusted between 0 and 100.

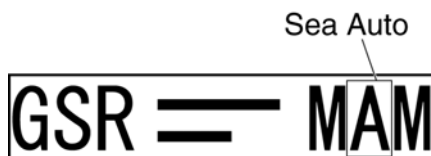

When the sea clutter suppression (Auto) is set to "0"

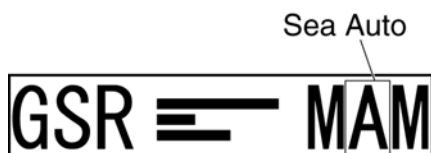

When the sea clutter suppression (Auto) is set to "10"

■ Canceling Automatic Sea Clutter Suppression Function

- 1 Hold down the [SEA] control.



Automatic function is canceled.

The mode is indicated as shown below.

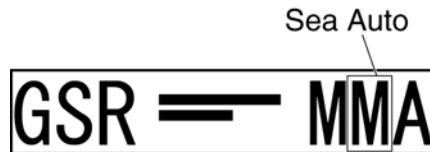

Reference:

When the automatic mode is selected for the sea clutter suppression function, the rain/snow clutter suppression function is switched to the manual mode.

The sea clutter suppression function (Auto) and the rain/snow clutter suppression function (Auto) cannot be selected at the same time.

2.6 RAIN/SNOW CLUTTER SUPPRESSION

This function suppresses rain/snow clutter returns.

 **CAUTION**



When using the sea clutter suppression function, never set the suppression level too high canceling out all image noises from the rain or snow at close range. Detection of not only echoes from the rain or snow but also targets such as other ships or dangerous objects will become inhibited.

When using the sea clutter suppression function, make sure to choose the most appropriate image noise suppression level.

■ Manual Rain/Snow Clutter Suppression Function

Adjust the rain/snow clutter returns on the display unit to achieve better observation state.

- 1 Turn the [RAIN] control.



Turn the [RAIN] control clockwise to suppress rain/snow clutter returns.

Turn the [RAIN] control counterclockwise to intensify rain/snow clutter returns.

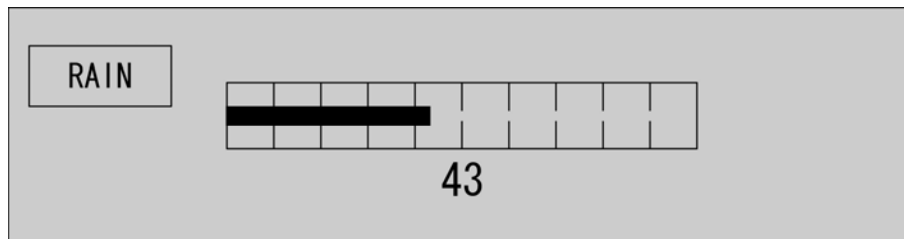

The rain/snow clutter suppression adjustment screen appears when turning the [RAIN] control.

Rain/snow clutter suppression can be adjusted between 0 and 100.

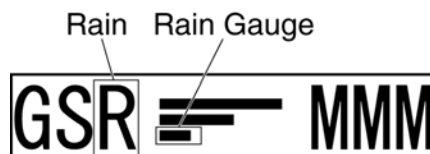

When turning the [RAIN] control, the rain/snow clutter control indication is stretched or shrunk.

● [RAIN] Control

When the [RAIN] control is turned clockwise, targets hidden by rain/snow clutter returns appear on the radar display. However, be careful that excessive suppression may cause small targets to be overlooked. Since the rain/snow clutter suppression function also has the effect of suppressing sea clutter, the suppression efficiency improves when using with the [SEA] control. In general, set the value to "0".

■ Automatic Rain/Snow Clutter Suppression Function

Rain/snow clutter suppression can be performed in accordance with the level of rain/snow clutter. Use this automatic mode when rain/snow clutter returns vary in direction.

- 1 Hold down the [RAIN] control.



Automatic function is selected.

Even when the automatic function is selected, you can manually perform fine adjustments by turning the [RAIN] control.

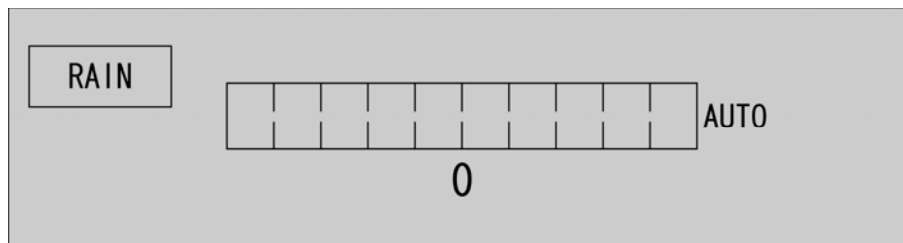

The rain/snow clutter suppression adjustment screen appears when turning the [RAIN] control. Rain/snow clutter suppression can be adjusted between 0 and 100.

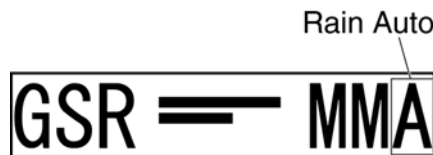

When the rain/snow clutter suppression (Auto) is set to "0"



When the rain/snow clutter suppression (Auto) is set to "10"

■ Switching to Manual/Automatic Mode

- 1 Hold down the [RAIN] control.



Automatic function is canceled.

The mode is indicated as shown below.



Reference:

When the automatic mode is selected for the rain/snow clutter suppression function, the sea clutter suppression function is switched to the manual mode.

The sea clutter suppression function (Auto) and the rain/snow clutter suppression function (Auto) cannot be selected at the same time.

2.7 SOFT KEY OPERATION

This radar can be operated with the soft keys and the MULTI control placed on the front panel of the display unit. You can access to functions without opening the menu screen.

To change the default settings, press the [MENU] key to open the menu screen.

This section describes the operation with the soft keys and the MULTI control.

■ Keys for operation

- Soft keys 1, 2, 3 and 4
- [MULTI] control
- [CLEAR] key

■ Soft Key Operations (Example: Opening "Display Screen")

This section describes how to operate with the soft keys shown below.

- TUNE/PRF
- Display Screen
- TM/RM
- Bearing Mode
- Pulse Length
- Off Center
- Symbol Display
- MOB
- Mark
- Line
- Own Track
- Event Mark
- AIS Filter
- TLL TX

- 1 Press the [[MULTI] control.

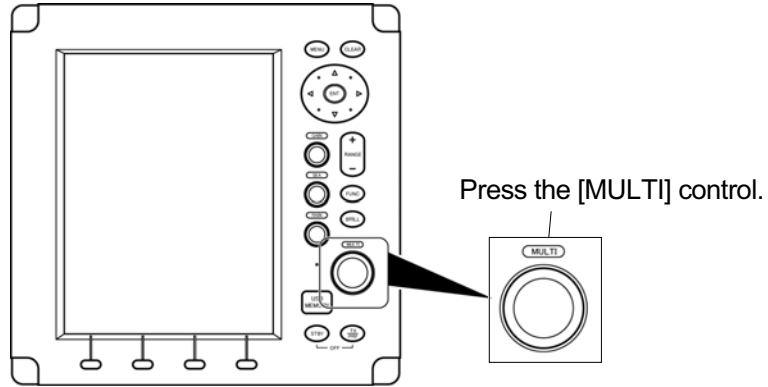

- 2 Turn the [MULTI] control to select Display Screen on the soft key menu.

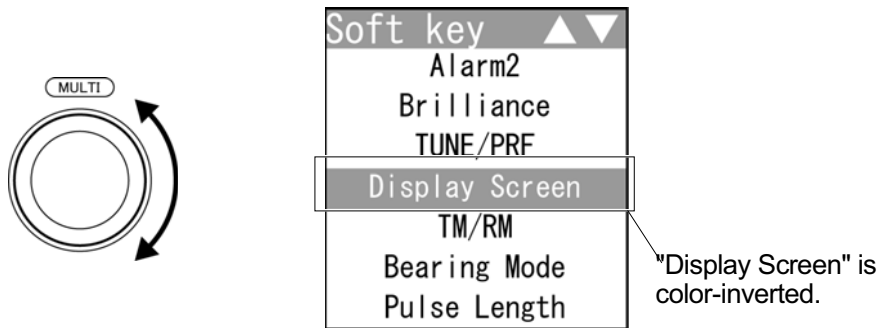

Reference:

When a certain time elapses without any key operation after selecting an item on the soft key menu, the soft key menu and the soft key display automatically disappear.

- Turning the [MULTI] control clockwise

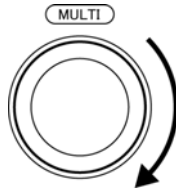

To select "Own Track" - "TLL TX"

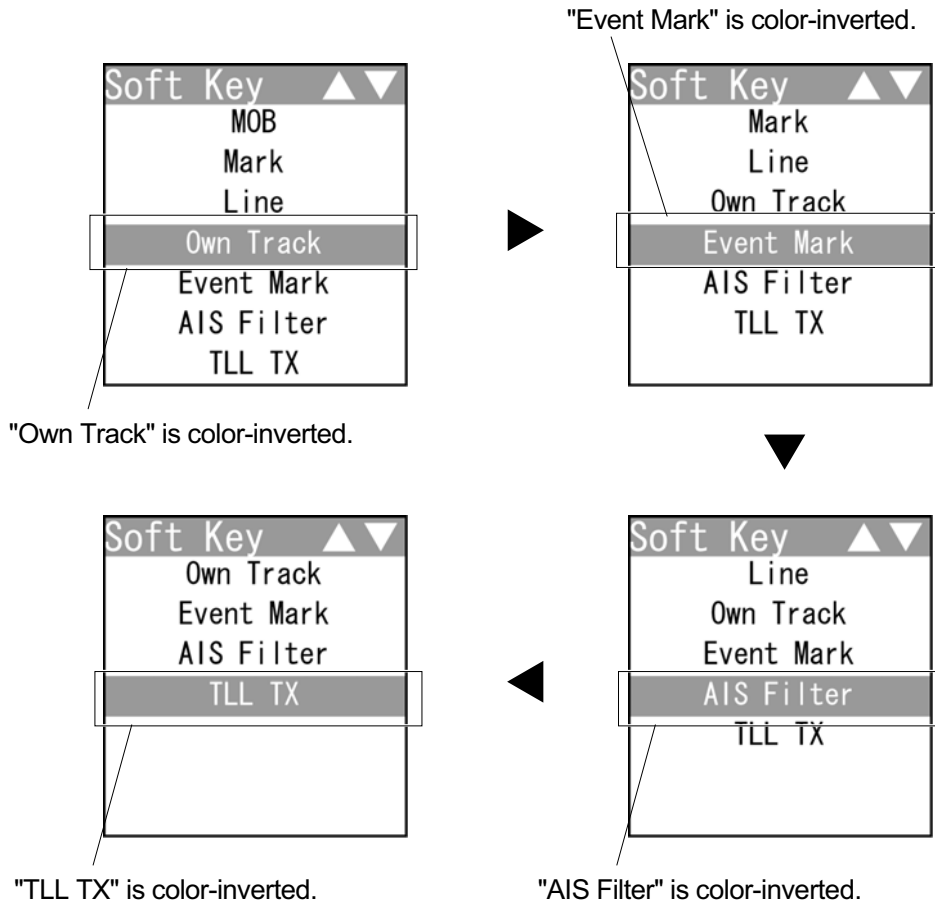

Reference:

When the item at the bottom of the soft key menu is color-inverted, the soft key menu does not scroll any more even if the control is turned clockwise.

- Turning the [MULTI] control counterclockwise

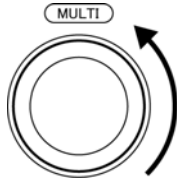

To select "VRM2" - "EBL1"

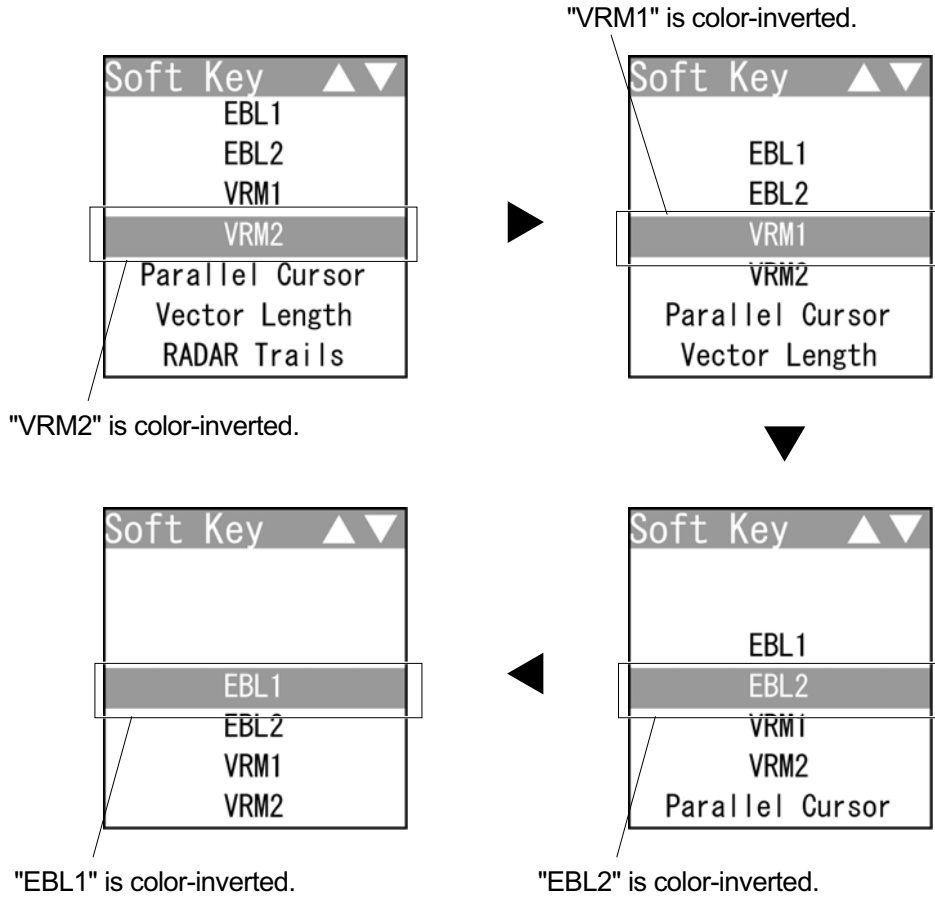

Reference:

When the item at the top of the soft key menu is color-inverted, the soft key menu does not scroll any more even if the control is turned counterclockwise.

● Soft key 1

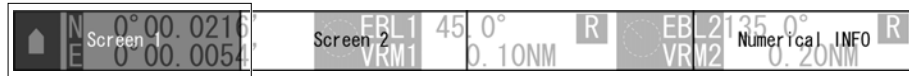

"Screen 1" is color-inverted.

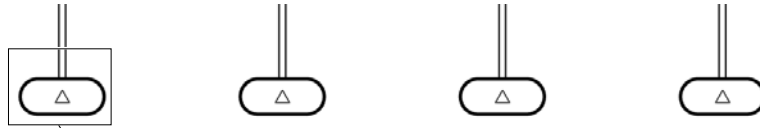

Press the [soft key 1].

The screen changes to the layout set in the section "4.13.7 LOCATION CHANGE" - "1. Screen1".

● Soft key 2



"Screen 2" is color-inverted.



Press the [soft key 2].

The screen changes to the layout set in the section "4.13.7 LOCATION CHANGE" - "2. Screen2".

● Soft key 4

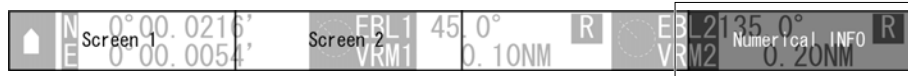

"Numerical INFO" is color-inverted.



Press the [soft key 4].

Each time you press the soft key 4 when "Numerical INFO" is set, the soft key display toggles in the following order:

"Numerical INFO" → "TT Detail" → "AIS Detail" → "Own AIS INFO"
→ "MOB INFO".

● Closing the soft key menu



Press the [CLEAR] key to turn off the soft key menu and the soft key display.

● Soft keys 1, 2, 3 and 4

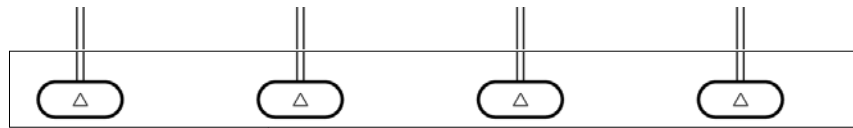

Press any of the soft keys.

If any of the soft keys is pressed when the soft key menu is turned off, the soft key menu and the soft key display which were displayed previously appear again.

■ "Soft key Operations (Example: Opening "Brilliance")

This section describes how to operate with the soft keys shown below.

- EBL1
- EBL2
- VRM1
- VRM2
- Parallel Cursor
- Vector Length
- RADAR Trails
- AIS
- TT
- Alarm1
- Alarm2
- Brilliance

1 Press a soft key.

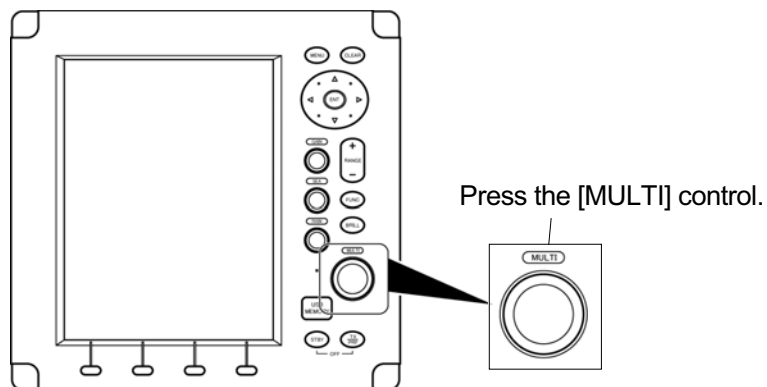

2 Turn the [MULTI] control to select Brilliance on the soft key menu.

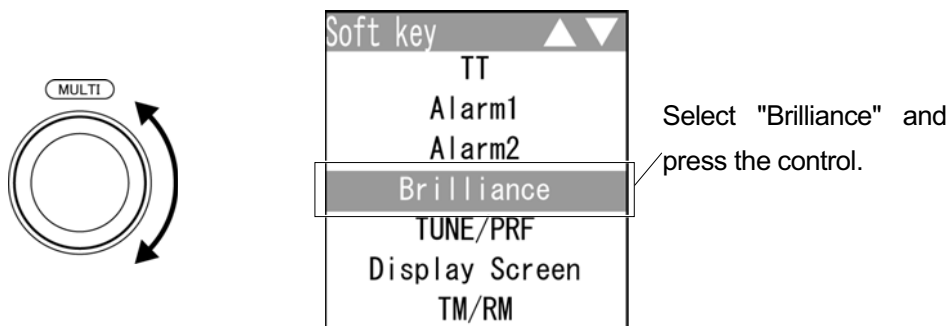

The soft key menu disappears and "Monitor BRILL" of the soft key display is color-inverted.

"Brilliance" is activated.

Reference:

Perform the same operations for the other soft key menu items to activate the functions.

● Soft key 1



"Monitor BRILL" is color-inverted.

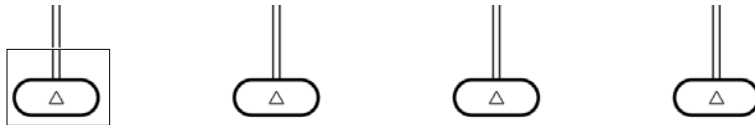

Press the [soft key 1].

When the soft key 1 is pressed, the display color is switched.

● Soft key 2



"Monitor BRILL" is color-inverted.



Press the [soft key 2].

"Monitor BRILL" is color-inverted, and is activated.

Press the [BRILL] key to adjust at eight levels.

Also, you can turn the [MULTI] control to change the level.

● Setting with the soft key menu

To determine the setting of the soft key menu item, press one of the followings:

- [Multi] control
- [CLEAR] key

The soft key menu item is determined, then the soft key menu and the soft key display are turned off and the setting is finished.

- Soft keys 1, 2, 3 and 4

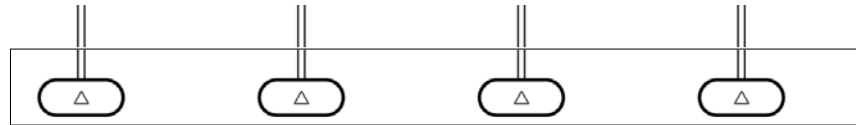

Press any of the soft keys.

If any of the soft keys is pressed when the soft key menu is turned off, the soft key menu and the soft key display which were displayed previously appear again, and the function is activated.

2.7.1 MEASURING TARGET BEARING (EBL)

Measures bearing with EBLs (Electronic Bearing Lines).

- 1 Select **EBL1** **EBL2** on the soft key menu.

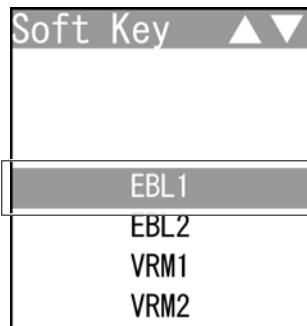

Select "EBL1" and press the control.

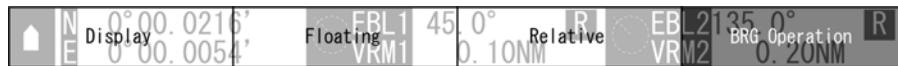

When "EBL1" is selected, the soft key menu is turned off and "BRG Operation" of the soft key display is color-inverted.

"EBL1" is activated.

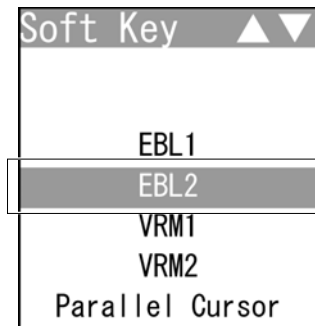

Select "EBL2" and press the control.

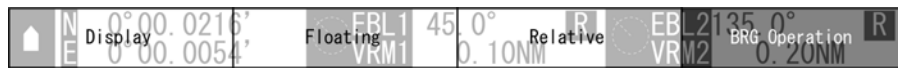

When "EBL2" is selected, the soft key menu is turned off and "BRG Operation" of the soft key display is color-inverted.

"EBL2" is activated.

2 Operate with the soft keys.

Soft key 1:

"Display Off": "EBL1"/"EBL2" is not displayed.

"Display": "EBL1"/"EBL2" is displayed.

Reference:

When "Display Off" is selected for the soft key 1, the equipment performs the followings:

- EBL is not displayed.
- The soft key menu and the soft key display disappears, and EBL function is terminated.

Soft key 2:

When pressing the soft key 2, "Floating" is color-inverted.

The starting point of the currently operating EBL can be switched from the center of the radar display (floating off) to floating state.

Press the cursor keys to move the starting point of "EBL1"/"EBL2".

Press the [ENT] key at the starting point of "EBL1"/"EBL2" you want to move.

The starting point of "EBL1"/"EBL2" is determined.

Reference:

The floating position of the EBL's starting point can be fixed on the radar display or at specific latitude and longitude.

Floating function must be turned on to use floating.

For details of settings, refer to "2.11.1 SETTING OPERATIONS FOR EBLs (ELECTRONIC BEARING LINES)".

Soft key 3:

Sets whether to display EBLs (Electronic Bearing Lines) in true bearing mode or relative bearing mode.

"True": "EBL1"/"EBL2" is displayed in true bearing mode.

"Relative": "EBL1"/"EBL2" is displayed in relative bearing mode.

Reference:

Bearing signal input is required to display true motion.

Soft key 4: BRG Operation

When "EBL1" or "EBL2" of the soft key menu is selected, "BRG Operation" of the soft key display is color-inverted.

Turn the [MULTI] control to change the direction of "EBL1"/"EBL2".

To determine the setting of "EBL1"/"EBL2", press one of the followings: the [MULTI] control, the soft key 4 or the [CLEAR] key.

The bearing is set and operation state ends.

Reference:

When "EBL1"/"EBL2" is not selected on the soft key menu, press the soft key 4 to activate the EBL function.

■ EBL Bearing Display

The bearing values of EBL1 and EBL2 displayed on the PPI are indicated at the radar display.

Even if EBL1 and EBL2 are not displayed, the bearing values are displayed.

2.7.2 MEASURING RANGE TO TARGET (VRM)

Measures the range with VRM (Variable Range Marker).

- 1 Select VRM1 VRM2 on the soft key menu.

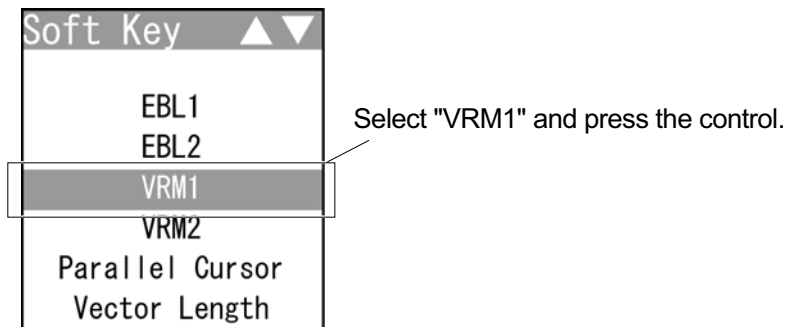

When "VRM1" is selected, the soft key menu is turned off and "DIST Operation" of the soft key display is color-inverted.

"VRM1" is activated.

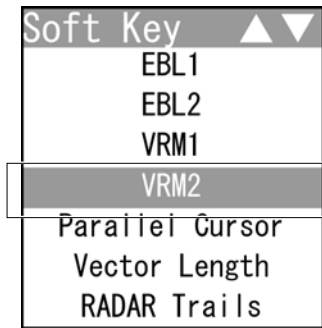

Select "VRM2" and press the control.

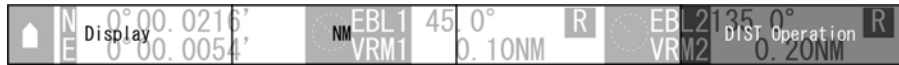

When "VRM1" is selected, the soft key menu is turned off and "DIST Operation" of the soft key display is color-inverted.

"VRM2" is activated.

2 Operate with the soft keys.

Soft key 1:

"Display Off": "VRM1"/"VRM2" is not displayed.

"Display": "VRM1"/"VRM2" is displayed.

Reference:

When "Display Off" is selected for the soft key 1, the equipment performs the followings:

- VRM is not displayed.
- The soft key menu and the soft key display disappears, and VRM function is terminated.

Soft key 2:

Selects units of "VRM1"/"VRM2" range.

Soft key 3: Not available

Soft key 4:

When "VRM1" or "VRM2" of the soft key menu is selected, "DIST Operation" of the soft key display is color-inverted.

Turn the [MULTI] control to operate "VRM1"/"VRM2".

Press the [MULTI] control, the soft key 4 or the [CLEAR] key to determine the "VRM1" and "VRM2" settings. Distance is set and operation state ends.

Reference:

When "VRM1"/"VRM2" is not selected on the soft key menu, press the soft key 4 to activate the VRM function.

■ Variable Range Marker

VRM1 is represented as a broken line, and VRM2 as a dotted line. When EBL1 is displayed, VRM1 marker appears on the EBL1. When EBL2 is displayed, VRM2 marker appears on the EBL2.

If the starting point of an EBL is offset, the center of a VRM marker is positioned at the starting point of the EBL.

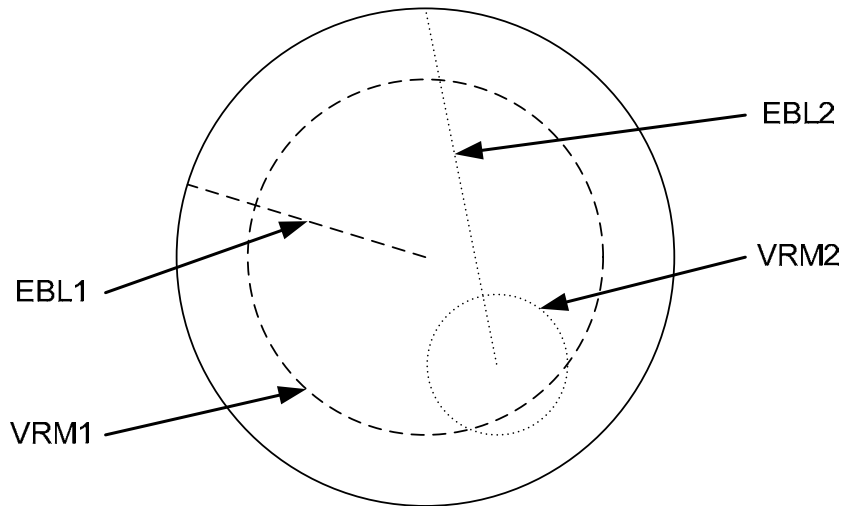

2.7.3 DISPLAYING PARALLEL CURSORS

Displays parallel cursors.

- 1 Select **Parallel Cursor** on the soft key menu.

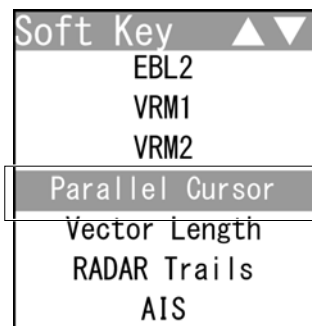

Select "Parallel Cursor" and press the control.

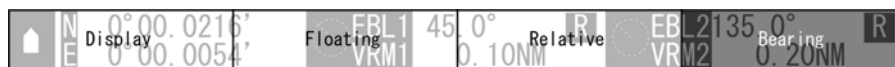

The soft key menu disappears and "BRG Operation" of the soft key display is color-inverted.

"Parallel Cursor" is activated.

2 Operate with the soft keys.

Soft key 1: Display Off Display

Displays/hides parallel cursors.

"Display Off": The parallel cursors are not displayed.

"Display": The parallel cursors are displayed.

Reference:

When "Display Off" is selected for the soft key 1, the equipment performs the followings:

- "Parallel Cursor" is not displayed.
 - The soft key menu and the soft key display disappears, and Parallel Cursor function is terminated.
-

Soft key 2: Floating

When pressing the soft key 2, "Floating" is color-inverted.

The starting point of the currently operating parallel cursor can be switched from the center of the radar display (floating off) to floating state.

Press the cursor keys to move the starting point of "Parallel Cursor".

Press the [ENT] key at the starting point of "Parallel Cursor" you want to move.

The starting point of "Parallel Cursor" is determined.

Reference:

The floating position of the parallel cursor starting point can be fixed on the radar display or at specific angle.

Floating function must be turned on to use floating.

For details of settings, see "2.11.2 SETTING OPERATIONS FOR PARALLEL CURSORS".

Chapter 2 OPERATIONS
2.7 SOFT KEY OPERATION

Soft key 3: True Relative

Sets whether to display parallel cursors in true bearing mode or relative bearing mode.

"True": "Parallel Cursor" is displayed in true bearing mode.

"Relative": "Parallel Cursor" is displayed in relative bearing mode.

Reference:

Bearing signal input is required to display true motion.

Soft key 4: Bearing Interval

When "Parallel Cursor" of the soft key menu is selected, "BRG Operation" of the soft key display is color-inverted.

When "Bearing" is displayed above the soft key 4

Turn the [MULTI] control to change the direction of "Parallel Cursor".

Press the soft key 4 to determine the bearing setting of "Parallel Cursor" for length setting.

Length setting can be operated.

Press the [MULTI] control or the [CLEAR] key when you want to set the bearing only. Bearing is set and operation state ends.

When "Interval" is displayed above the soft key 4

Turn the [MULTI] control to change the length of "Parallel Cursor".

Press the [MULTI] control, the soft key 4 or the [CLEAR] key to determine the length setting of "Parallel Cursor". Length is set and operation state ends.

Reference:

When "Parallel Cursor" is not selected on the soft key menu, press the soft key 4 to activate the Parallel Cursor function.

2.7.4 SETTING VECTORS

Sets TT and AIS vectors.

Reference:

The bearing and speed signal input are required to display TT and AIS vectors.

- 1 Select **Vector Length** on the soft key menu.

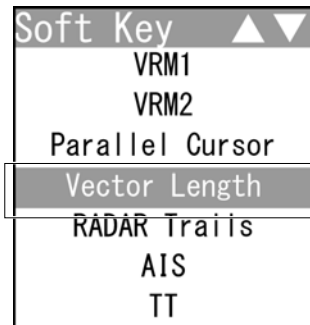

Select "Vector Length" and press the control.

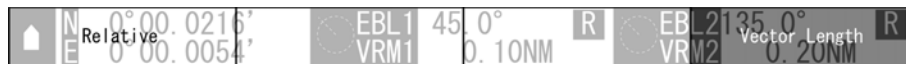

The soft key menu disappears and "Vector Length" of the soft key display is color-inverted.

"Vector Length" is activated.

- 2 Operate with the soft keys.

Soft key 1: **True** **Relative**

Switches between true vector mode and relative vector mode.

Soft key 2: Not available

Soft key 3: Not available

Soft key 4: **Vector Length**

When "Vector Length" of the soft key menu is selected, "Vector Length" of the soft key display is color-inverted.

Vector time can be set in minutes in the range 1 to 60 min.

Turn the [MULTI] control to set the vector length.

Reference:

When "Vector Length" is not selected on the soft key menu, press the soft key 4 to activate the Vector Length function.

■ Vector display

Note:

- When a target or own ship changes its course, or when a new target is acquired, its vector may not reach a given level of accuracy until three minutes or more has passed after such course change or target acquisition. Even if three minutes or more has passed, the vector may include an error depending upon the tracking conditions.

A vector to represent a target's predicted position can be presented in the True vector or Relative vector mode. In each mode, a vector length can be freely changed for a time interval of 1 to 60 minutes.

■ Vector Modes

● True Vector Mode

In the true vector mode, the direction of a target vector indicates the true course of the target and its vector length is proportional to its speed.

In this mode, own ship's vector is displayed as shown below.

In this mode, the movements of other ships around own ship can be accurately and easily monitored.

However, no CPA RING can appear in this mode.

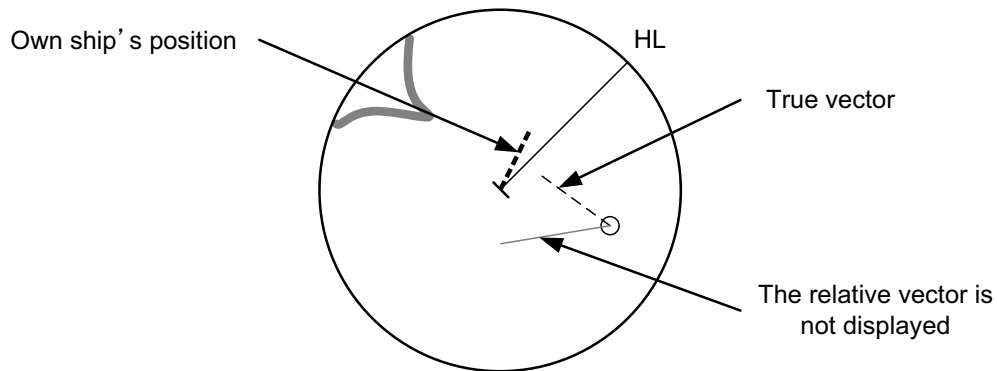

● Relative Vector Mode

The relative vector does not represent the true motion of the target, but its relative relation with own ship. This means that a target with its relative vector directed to own ship (passing through the CPA LIMIT ring) will be a dangerous target.

In the Relative Vector mode, it can be seen at a glance where the CPA LIMIT of the dangerous target is.

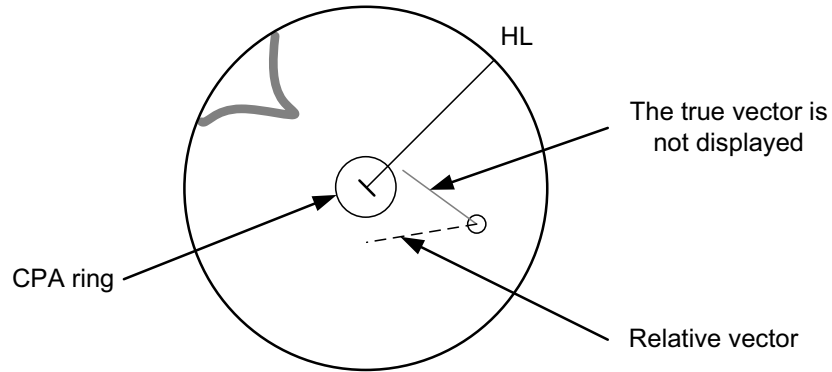

Therefore, the TRUE/REL mode shall optionally be used for the purpose of observation: the TRUE vector mode for grasping the true aspect of a target, and the REL vector mode for grasping a target's closest point of approach (CPA).

■ Vector Length

The vector length of a target is proportional to its speed, and the vector time can be switched in a range of 1 to 60 minutes.

The diagram below illustrates a vector length of a target for six minutes, and the tip of the vector represents the target's position expected to reach six minutes later.

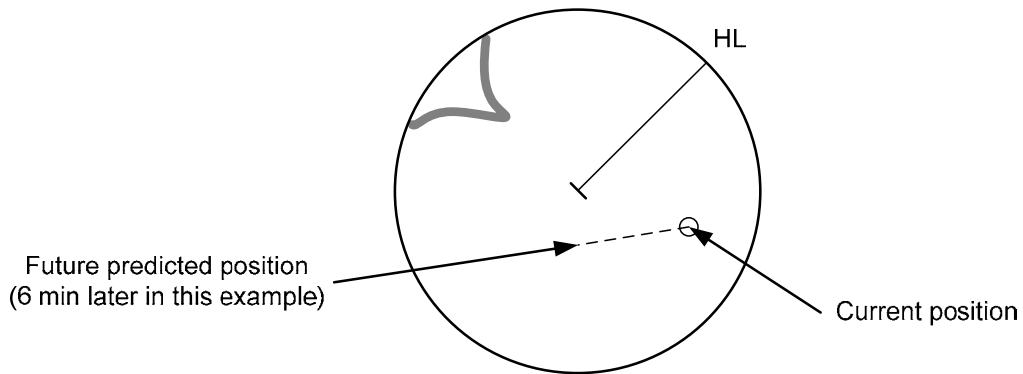

2.7.5 DISPLAYING OTHER SHIP'S TRACKS (RADAR TRAILS)

Sets radar trails.

Other ships' movements and speeds can be monitored from the lengths and directions of their trails, serving for collision avoidance.

- 1 Select on the soft key menu.

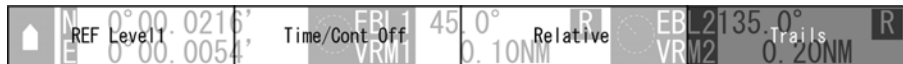
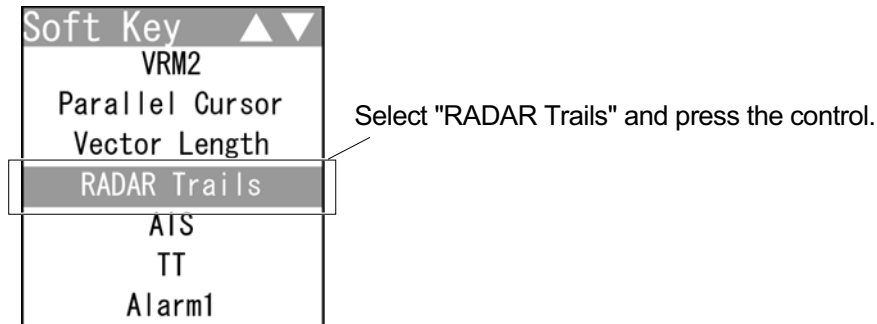

The soft key menu disappears and "Trails" of the soft key display is color-inverted. "RADAR Trails" is activated.

- 2 Operate with the soft keys.

Soft key 1:

Selects a radar video level required for plotting radar trails.

"REF Level1" is the lowest level while "REF Level4" is the highest level.

- When radar trails are plotted with unwanted waves, change to a higher level.
- To thin radar trails, change to a higher level.
- If radar trails are plotted in snatches, change to a lower level.

Soft key 2:

This function superimpose-displays time radar trails and continuous radar trails.

When "Time/Cont Off" is selected, this superimpose-display is disabled.

When "Time/Cont On" is selected, this superimpose-display is enabled.

Soft key 3:

Switches the radar trail display between true and relative motion trail modes.

True motion trails:

The system plots the absolute motion trails of a target, irrespective of the own ship's position.

The operator can easily judge the course and speed of the target.

The system does not plot the trails of land and other fixed targets.

Relative motion trails:

The system plots the trails of a target at a position relative to the own ship.

The operator can easily judge whether the target is approaching the own ship.

While the own ship is moving, the system also plots the trails when the own ship is turning.

Reference:

True bearing signal input and speed signal input are required to display radar trails in true motion trail mode.

Soft key 4: Trails

When "RADAR Trails" of the soft key menu is selected, "Trails" of the soft key display is color-inverted.

Turn the [MULTI] control to change the radar trail length.

Reference:

When "RADAR Trails" is not selected on the soft key menu, press the soft key 4 to activate the RADAR Trails function.

Short:

Off/15sec/30sec/1min/2min/3min/4min/5min/6min/10min/15min/All

Middle:

Off/30sec/1min/2min/3min/4min/5min/6min/10min/15min/All

Long:

Off/1min/2min/3min/4min/5min/6min/10min/15min/30min/1hr/All

Super Long:

Off/30min/1hr/2hr/3hr/4hr/5hr/6hr/10hr/12hr/24hr/All

To select the maximum time for displaying radar trails, see Section "2.10 RADAR TRAIL LENGTH SETTING")

2.7.6 AIS OPERATIONS

The AIS function shows the target's information on the radar display, using other ship's information sent out from the AIS unit.

Reference:

- The inputs of heading, latitude/longitude and AIS signal are required to display AIS.
- For detail settings of AIS functions, see "2.15 SETTING TT/AIS".

- 1 Select **AIS** on the soft key menu.

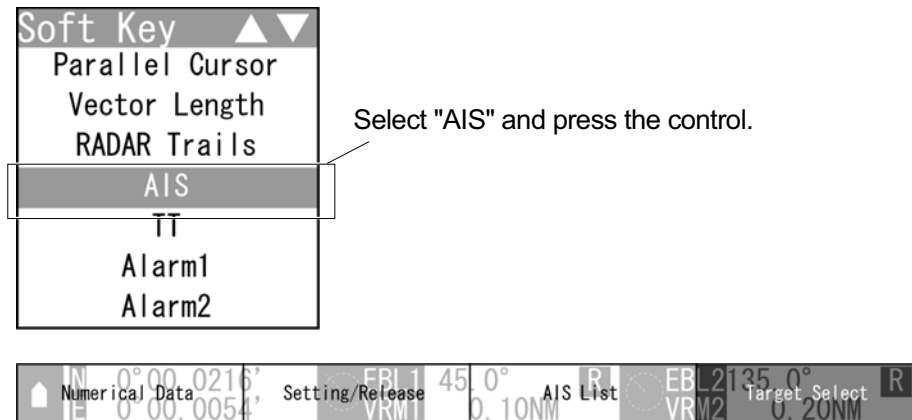

The soft key menu disappears and "Target Select" of the soft key display is color-inverted.

"AIS" is activated.

- 2 Operate with the soft keys.

Soft key 1: **Numerical Data** **Retrieved Vessel** **DEST Ship**

"Numerical Data": The mode is set to AIS numerical data display selection mode.

"Retrieved Vessel": The mode is set to AIS retrieved vessel selection mode.

"DEST Ship": The mode is set to AIS destination ship selection mode

Soft key 2: **Setting/Release**

AIS data display (numerical display, retrieved vessel and destination ship) can be set/released.

Soft key 3: **AIS List** **AIS Number SEL**

"AIS List": AIS list is displayed.

"AIS Number SEL": AIS list is not displayed.

Soft key 4: **Target Select**

When "AIS" of the soft key menu is selected, "Target Select" of the soft key display is color-inverted.

Sets the numerical display, retrieved vessel and destination ship.

Reference:

When "AIS" is not selected on the soft key menu, press the soft key 4 to activate the AIS function.

■ AIS Retrieved Vessel

AIS retrieved vessel is the function to preferentially display the user-specified ship.

■ AIS Destination Ship

AIS destination ship is the function to display the user-specified ship as the destination.

■ AIS data (Numerical Data, Retrieved Vessel, DEST Ship)

● Displaying AIS data (Operation with the soft key menu)

1 Press the cursor keys to select "AIS", then press the [ENT] key.

- When "Numerical Data" is displayed above the soft key 1



- When "Retrieved Vessel" is displayed above the soft key 1



- When "DEST Ship" is displayed above the soft key 1



The specified target data is displayed and the symbol is changed.

The target data will remain on the radar display until the target is lost, or until another target is designated.

Note:

- Numerical Data, AIS retrieved vessel and AIS destination ship can be operated when

Soft key 1:

are selected.

● Displaying AIS data (Operation with the [ENT] key)

AIS data (numerical display) can be done by the [ENT] key operation without displaying the soft key menu.

- 1 Press the cursor keys to select "AIS", then press the [ENT] key.



The selected AIS numerical display is set, and the "AIS" soft key is displayed.

Note:

- If operating with the [ENT] key when the soft key menu is closed, the equipment performs the followings:
 - On the AIS symbol: Opens the AIS soft key and the numerical display of AIS.
 - On the TT symbol: Opens the TT soft key and the numerical display of TT.
 - Not on the AIS or TT symbol:
 - Opens the TT soft key, it will be acquired.
- If operating with the [ENT] key when the AIS symbol overlaps the TT symbol, the numerical display of AIS symbol takes priority.

Reference:

- After setting the AIS numerical display, perform the same operations in "● Displaying AIS data (Operation with the soft key menu)".
 - AIS data (numerical data) is displayed when the soft key 4 is set to "AIS Detail" in the section "2.7.11 SETTING DISPLAY SCREEN".
-

● Releasing AIS data display

- 1 Press the cursor keys to select "AIS", then press the [ENT] key.

Numerical Data, AIS retrieved vessel and AIS destination ship are canceled.

■ Displaying the other AIS data

Reference:

- AIS retrieved vessel can be set by specifying MMSI number.
For details of settings, see "2.15.8 SETTING AIS RETRIEVED VESSEL".
- AIS destination ship can be set by specifying MMSI number.
For details of settings, see "2.15.7 SETTING AIS DESTINATION SHIP".

● Displaying AIS data

1 Turn the [MULTI] control to select "AIS", then press the soft key 3 "Setting/Release".

- When "Numerical Data" is displayed above the soft key 1



- When "Retrieved Vessel" is displayed above the soft key 1



- When "DEST Ship" is displayed above the soft key 1



The specified target data is displayed and the symbol is changed.

The target data will remain on the radar display until the target is lost, or until another target is designated.

No.	BRG [°] R	RNG [NM]	NAME	MMSI	▲ ▼
# 12	36.9	0.99		377470001	
\$ 15	109.7	1.02		377470003	
* 20	322.7	1.00		377470009	
11	359.7	1.00		377470000	
13	72.6	1.01		377470002	
14	287.2	1.02		377470008	
17	144.6	1.03		377470004	

When the target for the numerical display is set, "#" is displayed in the AIS list.

"#" disappears when the target is released.

Chapter 2 OPERATIONS
2.7 SOFT KEY OPERATION

When the AIS retrieved vessel is set, "*" is displayed in the AIS list.
 "*" disappears when it is released.
 When the AIS destination ship is set, "\$" is displayed in the AIS list.
 "\$" disappears when it is released.

Reference:

AIS data (Numerical Data) is displayed when the soft key 4 is set to "AIS Detail" in the section "2.7.11 SETTING DISPLAY SCREEN"

Note:

- Numerical Data, AIS retrieved vessel and AIS destination ship can be operated when

Soft key 1: Numerical Data Retrieved Vessel DEST Ship

are selected.



- Releasing AIS data display

1 Turn the [MULTI] control to select "AIS", then press the soft key 3 "Setting/Release".

Numerical Data, AIS retrieved vessel and AIS destination ship are canceled.

■ AIS Symbols

This section describes types and definitions of AIS symbols.

Symbol	Definition	Remarks
	Activated AIS target	This symbol shows the position of an AIS target on the PPI. The shape is an isosceles triangle, and its vertex shows the approximate heading direction. If heading bearing information or COG information is not received, the target is displayed toward PPI.
	Selection	When selecting an AIS target to display its numeric information, this symbol is superimpose-displayed on the selected target. This is displayed with a split square (basic color is white).
	AIS SART	This symbol shows the position of an AIS SART target on the PPI. This is displayed with a circle and cross lines.

■ Setting AIS Symbol Display

For details of displaying/hiding of the AIS symbols, see Section "2.7.16 SETTING SYMBOL".

2.7.7 TT OPERATIONS

The target tracking function calculates the course and speed of a target by automatically tracking the target's move.

Note:

- There are the following limitations on use of the target acquisition and target tracking functions.

[I] Resolution between adjacent targets and swapping during automatic target tracking

Depending on the particular distance and echo size, resolution between adjacent targets during automatic target tracking usually ranges somewhere between 0.03 to 0.05 NM. If multiple targets approach each other, resolution will become about 0.05 NM and this may cause the system to regard them as one target and thus to swap them or lose part of them. Such swapping or loss of targets may also occur if the picture of the target being tracked is affected by rain/snow clutter returns or sea clutter returns or moves very close to land.

[II] Intensity of echoes and the target tracking function

The intensity of echoes and the tracking function have a relationship, and thus the target will be lost if no echoes are detected during seven scans in succession.

If a lost target exists, therefore, radar gain must be increased to support detection of the target. If, however, radar gain is increased too significantly, sea clutter returns or other noise may be erroneously detected and tracked as a target, and resultingly, a false alarm may be issued.

To execute accurate tracking, it becomes necessary to appropriately adjust the [GAIN], [SEA] and [RAIN] controls of the radar so that the target to be acquired and tracked is clearly displayed on the radar display.

Inappropriate settings of these adjustments reduce the reliability / accuracy of automatic tracking.

 **CAUTION**



Use the radar only as a navigation aid.
The final navigation decision must always be made by the operator him/herself.
Making the final navigation decision based only on the radar display may cause accidents such as collisions or running aground.



Use the target tracking function (TT) only as a navigation aid. The final navigation decision must always be made by the operator him/herself.
Making the final navigation decision based only on the target tracking function (TT) information may cause accidents.
The target tracking function (TT) information such as vector, target numerical data, and alarms may contain some errors. Also, targets that are not detected by the radar cannot be acquired or tracked.
Making the final navigation decision based only on the radar display may cause accidents such as collisions or running aground.

- 1 Select TT on the soft key menu.

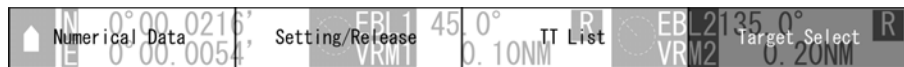
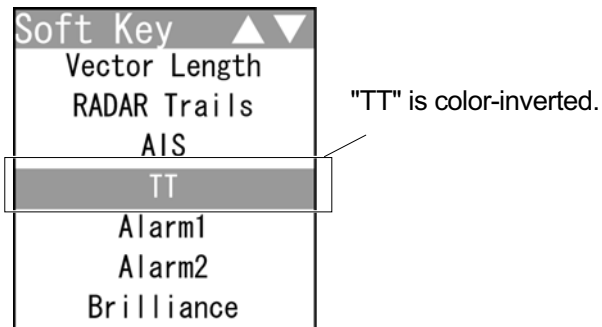

The soft key menu disappears and "Target Select" of the soft key display is color-inverted.

"TT" is activated.

- 2 Operate with the soft keys.

Soft key 1: Numerical Data TT Acquisition TT Release

"Numerical Data": The mode is set to TT numerical data display selection mode.

"TT Acquisition": The mode is set to TT acquisition selection mode.

"TT Release": The mode is set to TT release selection mode

Soft key 2: Setting/Release

Target tracking data (numerical display) can be set/released.

Soft key 3: TT List TT Number SEL

"TT List": TT list is displayed.

"TT Number SEL": TT list is not displayed.

Soft key 4: Target Select

When "TT" of the soft key menu is selected, "Target Select" of the soft key display is color-inverted.

Sets the numerical display, TT acquisition and TT release.

Reference:

When "TT" is not selected on the soft key menu, press the soft key 4 to activate the TT function.

■ Target acquisition

This equipment has automatic acquisition and manual acquisition.

● Manual acquisition (Operation with the soft key menu)

Note:

- Manual acquisition can be operated when

Soft key 1: TT Acquisition

are selected.

- If the range is switched, the acquisitions of targets acquired before switching the range are released when those targets get out of the echo radius.

- 1 Press the cursor keys to select the target for acquisition with the cursor, then press the [ENT] key.



An initial acquisition symbol appears.

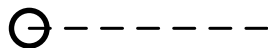

After one minute elapses, the target tracking symbol and vector are displayed.

Reference:

When the number of targets tracked has reached to the maximum (10 targets), any new target is not acquired.

Delete the unnecessary targets, then acquire new targets.

● Manual acquisition (Operation with the [ENT] key)

Target can be acquired by the [ENT] key operation without displaying the soft key menu.

Note:

- If operating with the [ENT] key when the soft key menu is closed, the equipment performs the followings:

On the AIS symbol: Opens the AIS soft key and the numerical display of AIS.

On the TT symbol: Opens the TT soft key and the numerical display of TT.

Not on the AIS or TT symbol:

Opens the TT soft key, it will be acquired.

- If operating with the [ENT] key when the AIS symbol overlaps the TT symbol, the numerical display of AIS symbol takes priority.

- 1 Press the cursor keys to select the target for acquisition with the cursor, then press the [ENT] key.



An initial acquisition symbol appears, and the "TT" soft key is displayed.

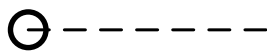

After one minute elapses, the target tracking symbol and vector are displayed.

Reference:

- When operating the [ENT] key on a TT symbol, the "TT" soft key and the target tracking data are displayed.
 - When operating the [ENT] key on an AIS symbol, the "AIS" soft key and the selected AIS data (numerical display) are displayed.
-

● Automatic acquisition

- 1 Perform the procedure as shown below to start automatic acquisition.

Open from the soft key menu.

Soft key 1:

Soft key 2:

Reference:

- If untracked targets intrude into the automatic acquisition area in the conditions that maximum number of targets (10 targets) is under tracking, the targets acquired automatically will be cancelled in the order of lower levels of danger.
- For details of automatic acquisition operation, refer to "2.7.8 DISPLAYING THE RADAR ALARM AND AUTOMATIC ACQUISITION OPERATIONS".

■ Deleting the unnecessary targets

Note:

- Releasing manual acquisition can be operated when
Soft key 1:
are selected.

- 1 Press the cursor keys to select the target for releasing with the cursor, then press the [ENT] key.

The target's vectors and symbols disappear, and only the radar video remains.

■ Target tracking data (numerical display)

Note:

- The numerical display can be operated when
Soft key 1:
are selected.

- Displaying tracking target data (Operation with the soft key menu)

- 1 Press the cursor keys to select the target for the numerical display with the cursor, then press the [ENT] key.



The specified target data is displayed and the symbol is changed.

The target data will remain on the radar display until the target is lost and its vector disappears, or until another target is designated.

Reference:

- If a target with the mark "O" is designated, only its true bearing and range will appear until its vector appears.
 - Tracking target data is displayed when the soft key 4 is set to "TT Detail" in the section "2.7.11 SETTING DISPLAY SCREEN"
-

● **Displaying tracking target data (Operation with the [ENT] key)**

The target tracking data can be displayed by the [ENT] key operation without displaying the soft key menu.

Note:

- If operating with the [ENT] key when the soft key menu is closed, the equipment performs the followings:
On the AIS symbol: Opens the AIS soft key and the numerical display of AIS.
On the TT symbol: Opens the TT soft key and the numerical display of TT.
Not on the AIS or TT symbol:
Opens the TT soft key, it will be acquired.
- If operating with the [ENT] key when the AIS symbol overlaps the TT symbol, the numerical display of AIS symbol takes priority.

- 1 Press the cursor keys to select the target for numerical display with the cursor, then press the [ENT] key.



The selected target tracking numerical display is set, and the "TT" soft key is displayed.

Reference:

After setting the TT numerical display, perform the same operations in "● Displaying tracking target data (Operation with the soft key menu)".

● **Releasing tracking target data display**

- 1 Press the cursor keys to select the target for the numerical display with the cursor, then press the [ENT] key.
Numerical data display is released.

■ Displaying the other tracking target data

Note:

- The numerical display can be operated when
Soft key 4: Target Select
are selected.

● Displaying tracking target data

- 1 Turn the [MULTI] control to select the target for the numerical display, then press the soft key 3 "Setting/Release".



The specified target data is displayed and the symbol is changed.

The target data will remain on the radar display until the target is lost and its vector disappears, or until another target is designated.

No.	BGR[°]R	RNG[NM]	COG[°]	SOG[kn]
# 1	302.5	0.65	33.2	9.9
2	303.9	1.15	36.0	15.2
3	308.0	1.66	20.0	10.0
4	268.4	1.51	337.9	8.7
5	265.8	0.79	20.6	10.0
6	39.2	0.98	9.5	11.2
8	316.2	0.73	4.4	12.2

When the target for the numerical display is set, "#" is displayed in the TT list.

"#" disappears when the target is released.

Reference:







- If a target with the mark "○" is designated, only its true bearing and range will appear until its vector appears.
- Tracking target data is displayed when the soft key 4 is set to "TT Detail" in the section "2.7.11 SETTING DISPLAY SCREEN".

● Releasing tracking target data display

- 1 Turn the [MULTI] control to select the target for the numerical display, then press the soft key 3 "Setting/Release".
Numerical data display is released.

■ Target Tracking Symbols

This section describes types and definitions of target tracking symbols.

Symbol	Definition	Remarks
	Initial acquisition	This symbol is displayed where the target is acquired. This is displayed with a circle of thin dotted line (basic color is white). This symbol is also used for the target acquired automatically.
	Tracking target	This symbol is displayed for the target which becomes the tracking target after acquired. This is displayed with a circle of thick line (basic color is white).
	New tracking target	This symbol is displayed for the target which becomes the tracking target after automatically acquired. This is displayed with a circle of thick line (basic color is red). This is changed to a normal tracking target when acknowledged to new target alarm.
	Dangerous target	This symbol is displayed when the tracking target becomes a dangerous target with CPA/TCPA decision. This is displayed with a circle of thick line (basic color is red). This blinks while this is not acknowledged. Then, it stops blinking when it is acknowledged. When there are some dangerous targets, targets which is not acknowledged blinks, and targets which has been acknowledged does not blink.
	Lost	When a tracking target is no longer detected as a target, this symbol is superimpose-displayed on the target symbol. This is displayed with cross lines (basic color is red). This is superimpose-displayed on tracking targets, new tracking targets or dangerous targets.
	Selection	When selecting a tracking target to display its numeric information, this symbol is superimpose-displayed on the selected target. This is displayed with a split square (basic color is white). This is superimpose-displayed on tracking targets, new tracking targets or dangerous targets.

■ Setting Tracking Target Symbol Display

For details of displaying/hiding of the tracking target symbols, see Section "2.7.16 SETTING SYMBOL".

2.7.8 DISPLAYING THE RADAR ALARM AND AUTOMATIC ACQUISITION OPERATIONS

With a fan-shaped range made, the radar alarm can give an alarm to ships that enter or depart from the range.

- 1 Select Alarm1 Alarm2 on the soft key menu.

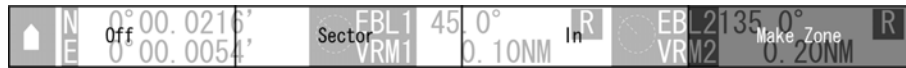
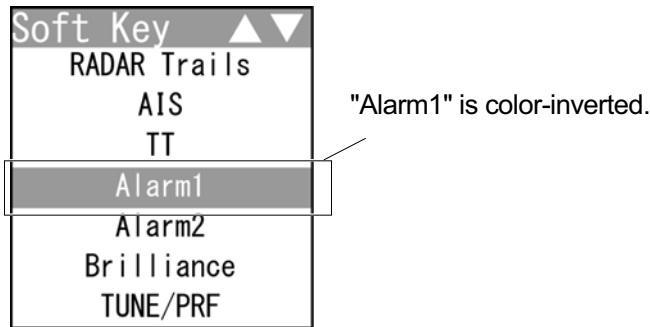

The soft key menu disappears and "Make Zone" of the soft key display is color-inverted.

"Alarm1" is activated.

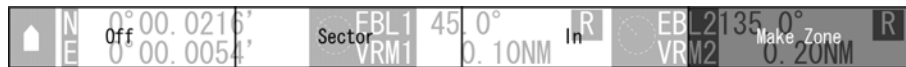
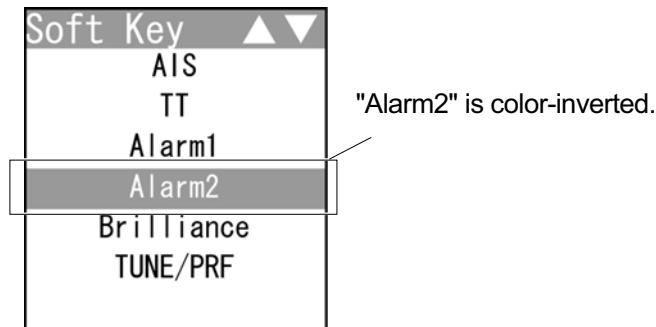

The soft key menu disappears and "Make Zone" of the soft key display is color-inverted.

"Alarm2" is activated.

2 Operate with the soft keys.

Soft key 1: When Alarm1 is selected

When Alarm2 is selected

Turns on/off the alarm display.

Soft key 2: When Alarm1 is selected

When Alarm2 is selected

"Sector":

Displays a fan-shaped radar alarm.

"Rectangle":

Displays a rectangle-shaped radar alarm.

"AZ1" "AZ2":

Displays the acquisition area.

Soft key 3: When Alarm1 is selected

When Alarm2 is selected

Sets the alarm issuing conditions for the radar alarm.

"In": An alarm is issued when ship enters.

"Out": An alarm is issued when ship departs.

Soft key 4: When Alarm1 is selected

When Alarm2 is selected

"Make Zone" "Make Zone":

When "Make Zone" of the soft key menu is selected, "Target Select" of the soft key display is color-inverted.

Reference:

When "Alarm1"/"Alarm2" is not selected on the soft key menu, press the soft key 4 to activate the Alarm1/Alarm2 function.

■ Automatic acquisition operations

Reference:

If untracked targets intrude into the acquisition area in the conditions that maximum number of targets (10 targets) is under tracking, the targets acquired automatically will be cancelled in the order of lower levels of danger.

● Turning on the automatic acquisition

1 Perform the following settings.

Soft key 1: When Alarm1 is selected

When Alarm2 is selected

Soft key 2: When Alarm1 is selected

When Alarm2 is selected

The acquisition area is activated.



An initial acquisition symbol appears for an acquired target.

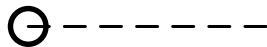

After one minute elapses, the target tracking symbol is displayed.

● Turning off the automatic acquisition

1 Perform the following settings.

Soft key 1: When Alarm1 is selected

When Alarm2 is selected

The acquisition area is deactivated.

The acquisition area disappears from the radar screen, however, the tracking target which has been already acquired are continued to be tracked.

■ Creating a fan-shaped radar alarm/acquisition area

- 1 Perform the following settings.

Soft key 2: When Alarm1 is selected

Sector AZ1

When Alarm2 is selected

Sector AZ2

The range setting is started for a fan-shaped radar alarm/acquisition area.

- 2 Press the cursor keys to move the cursor to the first point (setting of the start bearing and range), then press the [ENT] key.

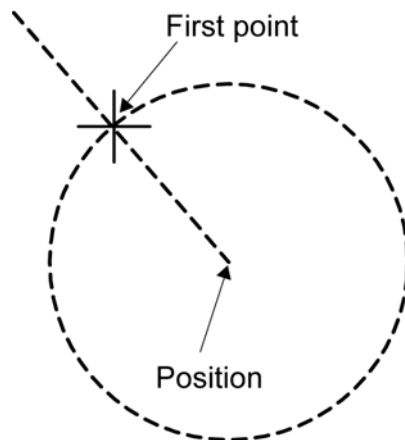

- 3 Press the cursor keys to move the cursor to the second point (setting of the end range), then press the [ENT] key.

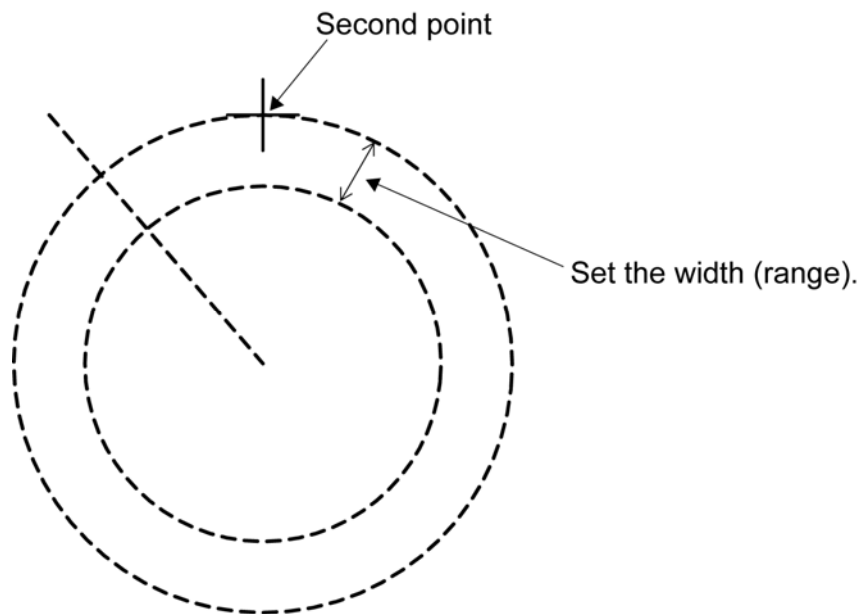

- 4 Press the cursor keys to move the cursor to the third point (setting of the end bearing), then press the [ENT] key.

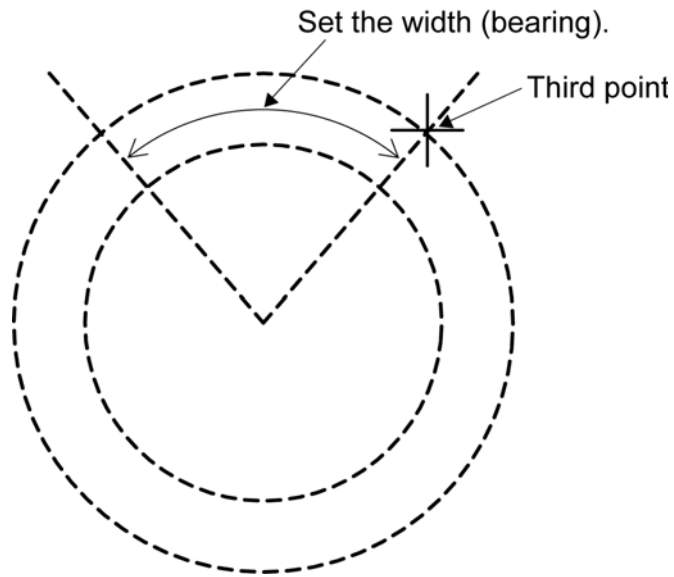

- 5 A fan-shaped radar alarm/acquisition area is determined.

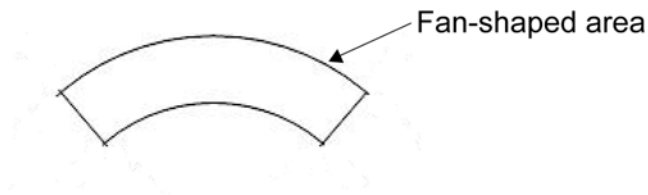

Reference:

After the fan-shaped radar alarm/acquisition area is determined, the soft key menu and the soft key display disappears, and Alarm1 function is terminated.

■ **Creating a rectangle-shaped radar alarm**

- 1 Perform the following settings.

Soft key 2: When Alarm1 is selected

When Alarm2 is selected

The range setting is started for a rectangle-shaped radar alarm.

- 2 Press the cursor keys to move the cursor to the first point (setting of the start latitude and longitude), then press the [ENT] key.

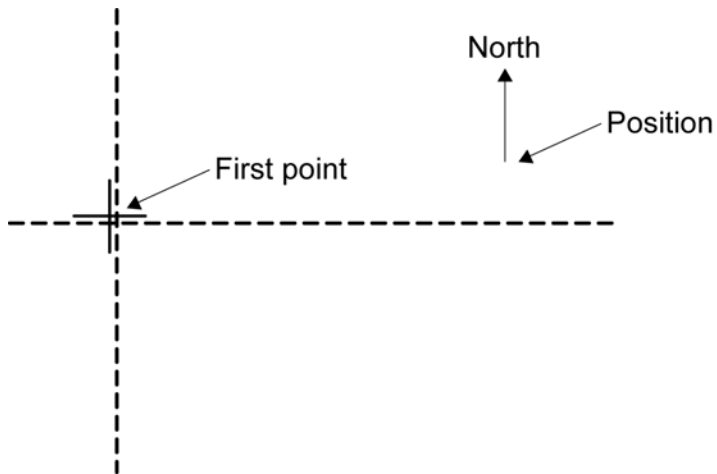

- 3 Press the cursor keys to move the cursor to the second point (setting of the end latitude), then press the [ENT] key.

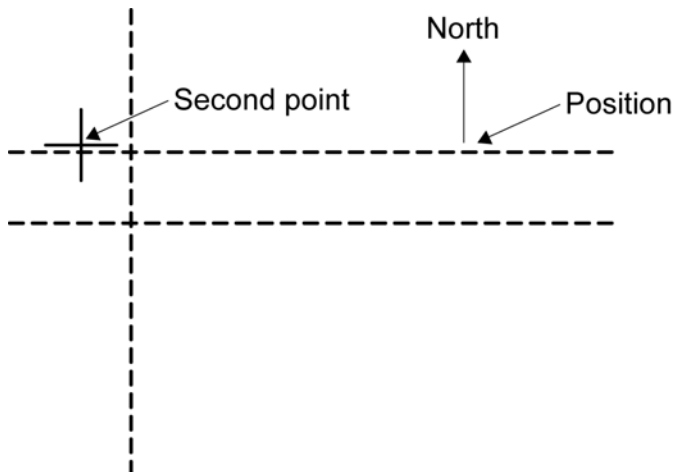

- 4 Press the cursor keys to move the cursor to the third point (setting of the end latitude), then press the [ENT] key.

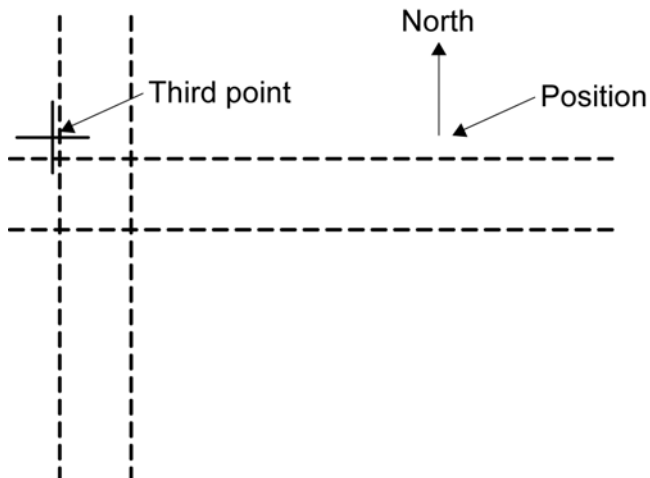

5 Rectangle-shaped area

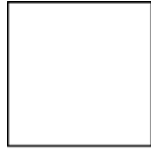

↙
Rectangle-shaped area

Rectangle-shaped area is set with Nup as reference.

Reference:

After the fan-shaped radar alarm/acquisition area is determined, the soft key menu and the soft key display disappears, and Alarm1 function is terminated.

2.7.9 SETTING DISPLAY BRILLIANCE AND DISPLAY COLOR

Display brilliance and display color can be changed.

- 1 Select **Brilliance** on the soft key menu.

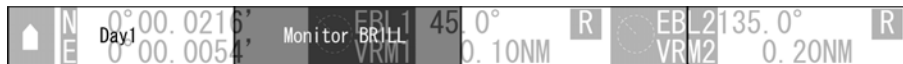
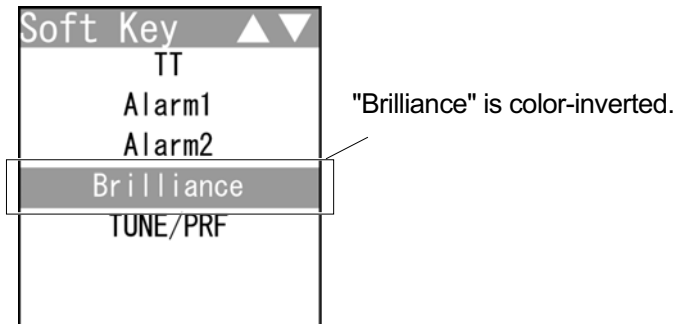

The soft key menu disappears and "Monitor BRILL" of the soft key display is color-inverted.

"Brilliance" is activated.

- 2 Operate with the soft keys.

Soft key 1: **Day1** **Day2** **Day3** **Dusk** **Night**

Display color is changed in accordance with the setting of "Main Menu" - "Display Color".

Each time the soft key 1 is pressed when "Day1" is displayed above the soft key 1, the setting changes in order of "Day2" → "Day3" → "Dusk" → "Night".

If "Main Menu" - "Display Color" - "Day1" - "Soft Key" is set to "Off", "Day1" is not displayed above the soft key 1.

Operate the same way for "Day2", "Day3", "Dusk" and "Night".

Soft key 2: **Monitor BRILL**

When "Brilliance" of the soft key menu is selected, "Monitor BRILL" of the soft key display is color-inverted.

Press the [BRILL] key to adjust at eight levels.

Also, you can turn the [MULTI] control to change the level.

Soft key 3: Not available

Soft key 4: Not available

Reference:

When "Brilliance" is not selected on the soft key menu, press the soft key 4 to activate the Brilliance function.

2.7.10 ADJUSTING SCANNER

There are automatic tuning mode (AUTO) and manual tuning mode (MAN). In the automatic tuning mode, transmission and receiving frequencies are tuned and adjusted automatically. In the manual tuning mode, tuning is carried out using the MULTI control.

- 1 Select **TUNE/PRF** on the soft key menu.

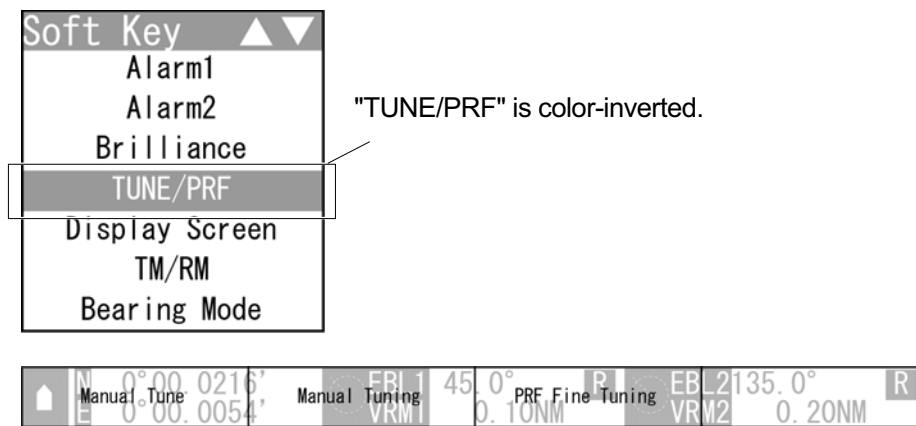

The "TUNE/PRF" soft key display appears.

- 2 Operate with the soft keys.

Soft key 1: **AUTO Tune** **Manual Tune**

Selects whether to use the tuning function in automatic or manual mode.

Soft key 2: **Manual Tuning**

When pressing the soft key 2, "Manual Tuning" is color-inverted.

- When "MAN" is displayed above the soft key 1
You can manually adjust using the MULTI control.

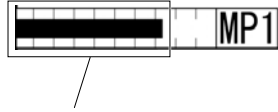

Tune indicator bar

Turn the MULTI control to adjust tuning.

Adjust the video to be the largest by observing the tune indicator bar.

Because the tune indicator bar is the guide during manual tuning, adjust the tune indicator bar to the maximum.

- When "AUTO" is displayed above the soft key 1
"Manual Tuning" is not color-inverted. The equipment automatically adjust tuning. Tuning is adjusted when transmission is started, the range is changed or pulse length is changed.

Soft key 3: **PRF Fine Tuning**

When pressing the soft key 3, "PRF Fine Tuning" is color-inverted.

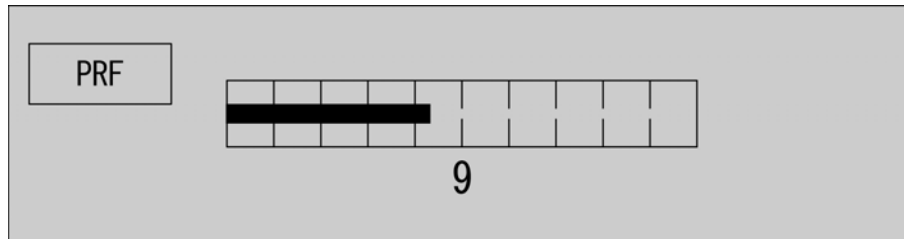

The PRF fine tuning screen appears.

Fine-tune the transmitting repetition frequency of the transmitter in the range 90 to 100%.

If radar's interference patterns are concentrically displayed, increment or decrement the set value by 3 to 4 in order to heighten the effect of interference rejection.

The same operation can be performed by pressing the [TX/PRF] key several times.

Use the [MULTI] control to perform PRF fine tuning between 0 and 31.

When the soft key 3 "PRF Fine Tuning" is pressed, color-inverted display returns to normal color.

Soft key 4: Not available

2.7.11 SETTING DISPLAY SCREEN

Sets the layout of radar screen.

- 1 Select on the soft key menu.

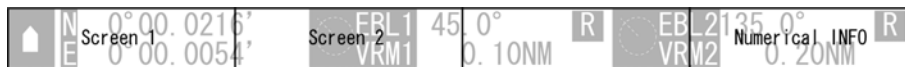
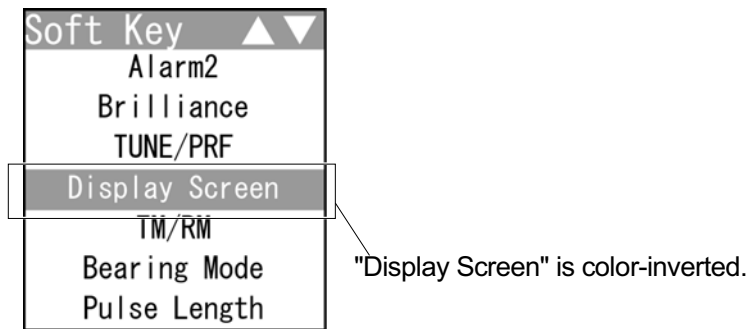

The "Display Screen" soft key display appears.

- 2 Operate with the soft keys.

Soft key 1:

The screen changes to the layout set with the menu "Adjust Menu" - "Display Screen" - "Location Change" - "Screen1".

Soft key 2:

The screen changes to the layout set with the menu "Adjust Menu" - "Display Screen" - "Location Change" - "Screen2".

Soft key 3: Not available

Soft key 4:

Each time you press the soft key 4 when "Numerical INFO" is set, the soft key display toggles in the following order:

"Numerical INFO" → "TT Detail" → "AIS Detail" → "Own AIS INFO"
→ "MOB INFO".

■ Numerical INFO

If "Screen1" has been set in the menu

When "Numerical INFO" is displayed above the soft key 4, "Numerical INFO" which has been set in the menu "Screen 1" is displayed.

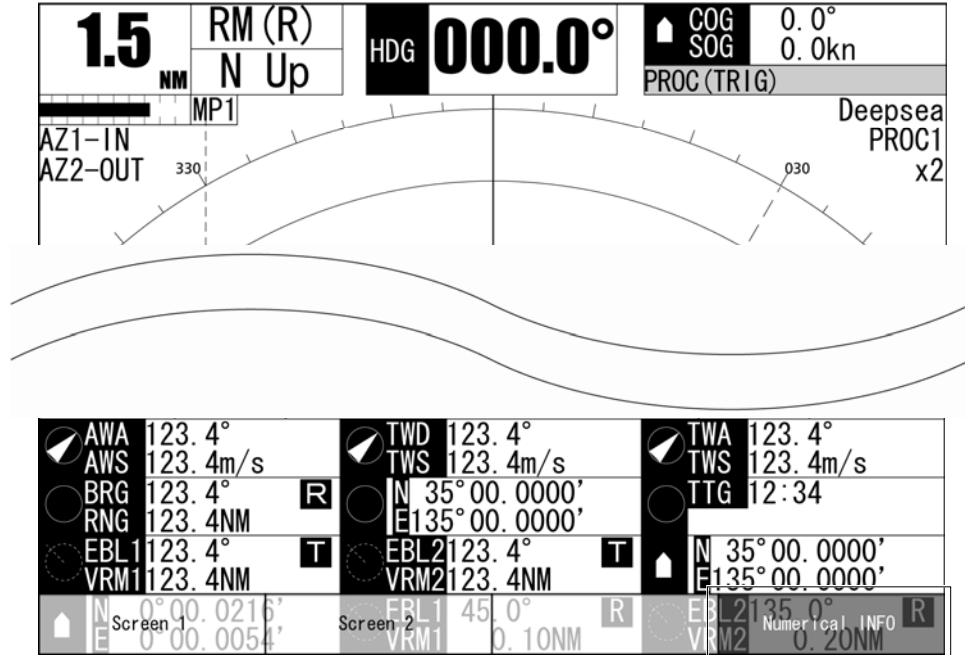

Numerical INFO

If "Screen2" has been set in the menu

When "Numerical INFO" is displayed above the soft key 4, "Numerical INFO" which has been set in the menu "Screen 2" is displayed.

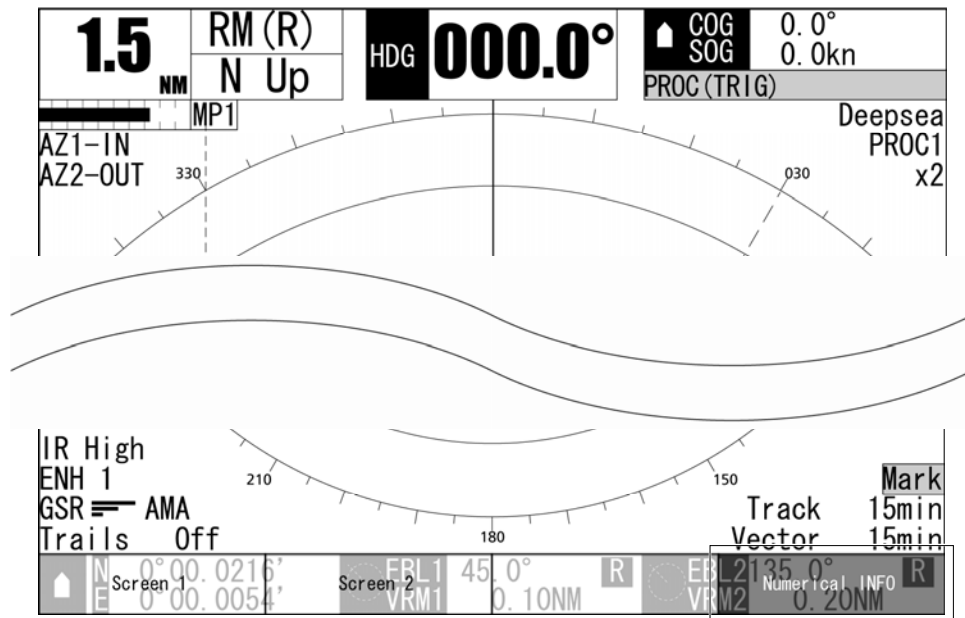

Numerical INFO

■ TT Detail

When "Numerical INFO" is displayed above the soft key 4, press the soft key 4 to display "TT Detail" on the radar screen.

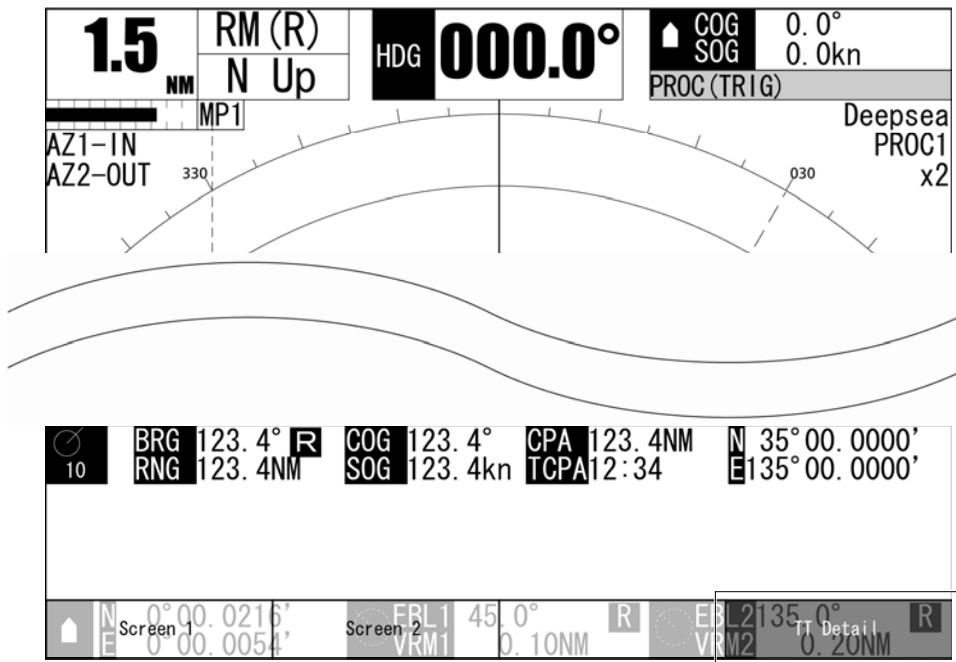

TT Detail

■ AIS Detail

When "TT Detail" is displayed above the soft key 4, press the soft key 4 to display "AIS Detail" on the radar screen.

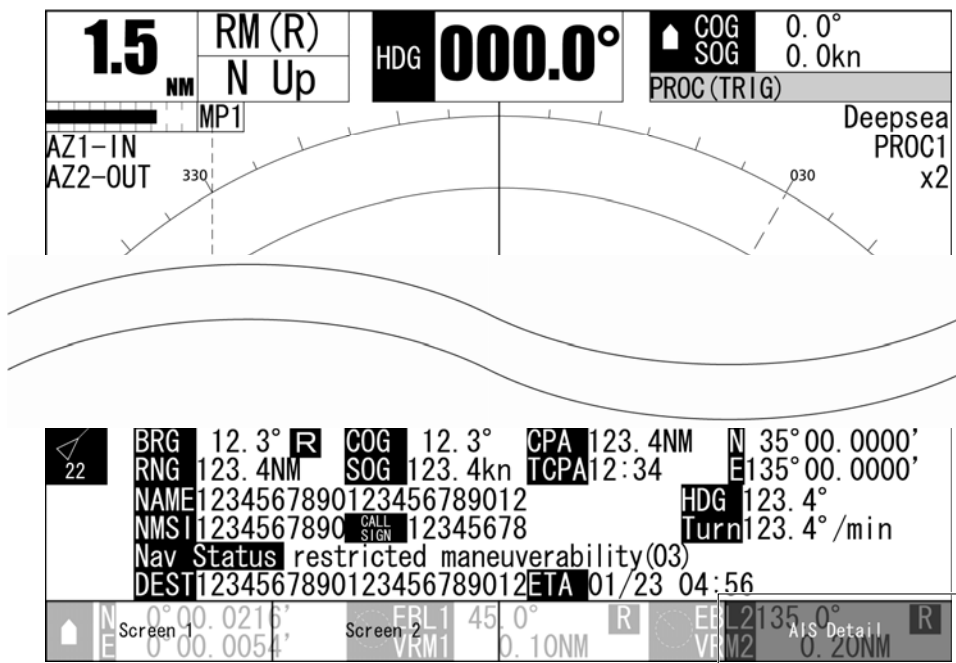

AIS Detail

■ Own AIS INFO

When "AIS Detail" is displayed above the soft key 4, press the soft key 4 to display "Own AIS INFO" on the radar screen.

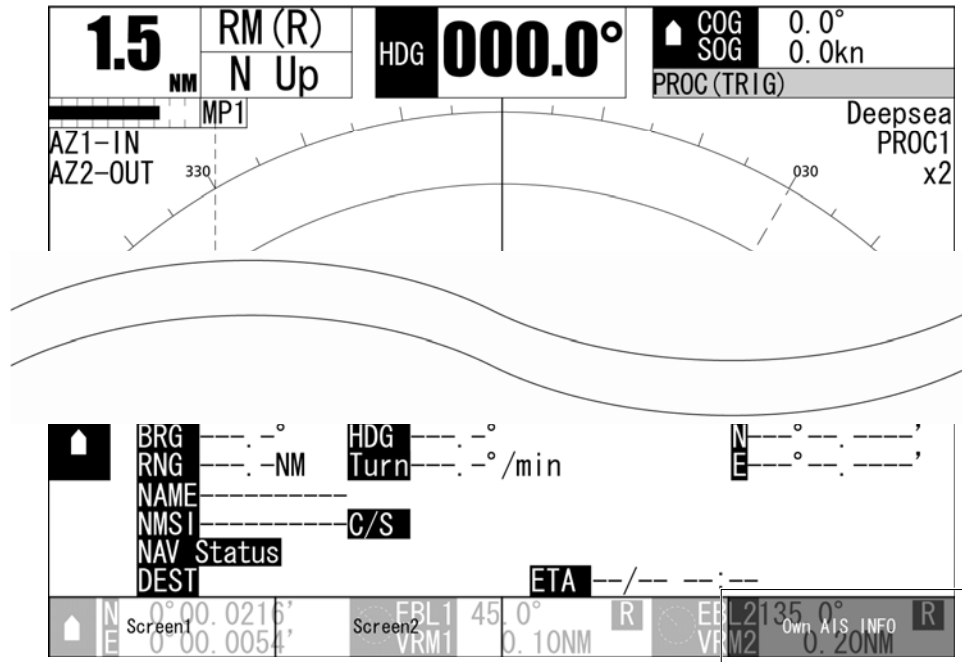

Own AIS INFO

■ MOB INFO

When "Own AIS INFO" is displayed above the soft key 4, press the soft key 4 to display "MOB INFO" on the radar screen.

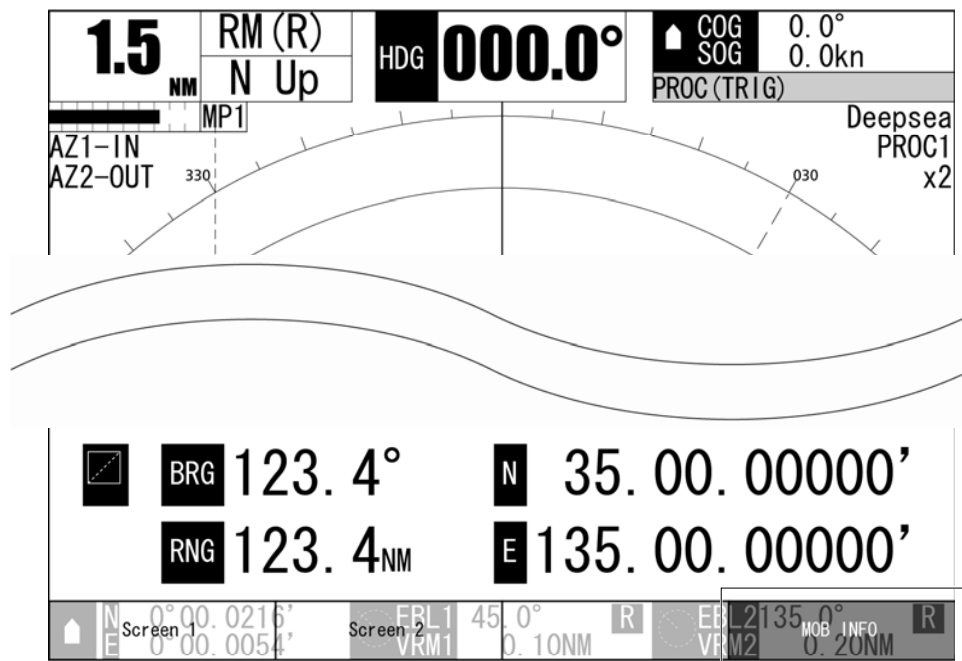

MOB INFO

■ Hiding the heading line

- 1 Hold down the [TX/PRF] key.



The ship's heading line is hidden while the [TX/PRF] key is held down.

The ship's heading line (HL) that presents the course of own ship is always shown on the radar display.

The heading line is hidden while the [TX/PRF] key is held down, so the targets on the heading line can be easily observed.

2.7.12 SWITCHING TO TRUE/RELATIVE MOTION DISPLAY MODE

Switches between true and relative motion display modes.

Reference:

The bearing signal input is required to display true motion.

- 1 Select **TM/RM** on the soft key menu.

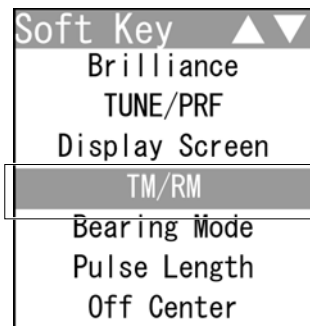

"TM/RM" is color-inverted.

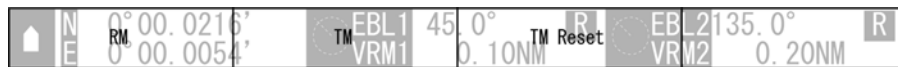

The "TM/RM" soft key display appears.

2 Operate with the soft keys.

Soft key 1: **RM**

Press the soft key 1 to switch to relative motion display.

Own ship returns to the center of the radar screen.

Soft key 2: **TM**

Press the soft key 2 to switch to true motion display.

Soft key 3: **TM Reset**

Press the soft key 3 during the true motion display mode, the own ship position is reset, as same as switching from relative motion display to true motion display.

Own ship starts from the reset position.

Soft key 4: Not available

■ True motion display

In the true motion display mode, the own ship's position on the radar screen moves depending upon its speed and course and the influence of the current. Land and other fixed targets are fixed on the radar screen and only actually moving targets move on the radar screen. When the true motion display mode is selected, the own ship's position is set to 66% of the display radius in the opposite direction to its course allowing for the influence of the current. Own ship starts moving depending upon its speed and course and the influence of the current. Subsequently, when own ship arrives at the position of 66% of the display radius, it is automatically reset to its initial position at 66% of the display radius in the opposite direction to its course allowing for the influence of the current.

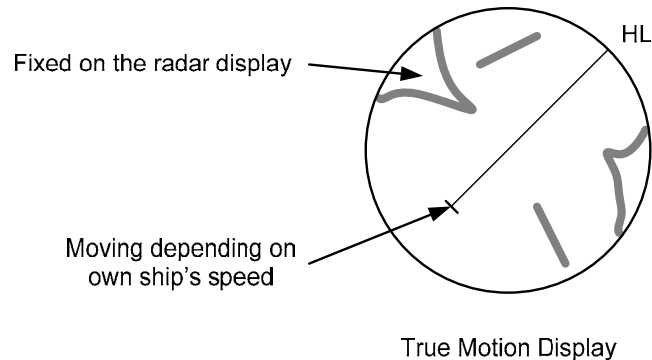

2.7.13 SWITCHING BEARING DISPLAY MODE

Selects the azimuth of the radar video.

Reference:

The bearing signal input is required to display N Up/C Up.

- 1 Select **Bearing Mode** on the soft key menu.

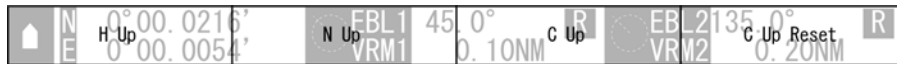
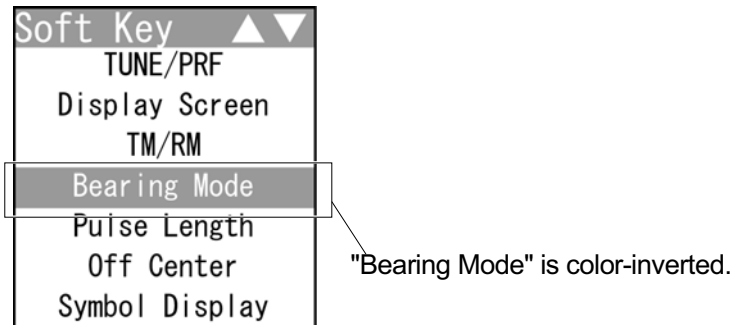

The "Bearing Mode" soft key display appears.

- 2 Operate with the soft keys.

Soft key 1: **H Up**

Relative bearing mode [Head Up] is selected.

Soft key 2: **N Up**

True bearing mode [North Up] is selected.

Soft key 3: **C Up**

Course-up bearing mode [Course Up] is selected.

Soft key 4: **C Up Reset**

In Course-up mode, reset the course-up display.

■ Relative Bearing Mode

The video is displayed so that the ship's heading line points to the zenith of the PPI (0° on range rings).

Since targets are displayed in their directions relative to the ship's heading line, the operator can view the video in the same field of view as in operating the ship at sea. This mode is suitable for watching over other ships.

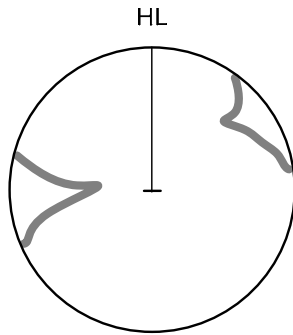

Head-up mode

■ True Bearing Mode

The video is displayed so that the zenith of the PPI (0° on range rings) points to the due north.

Fixed targets do not flicker and are easily identified on the chart, and the true bearing of a target can easily be read out.

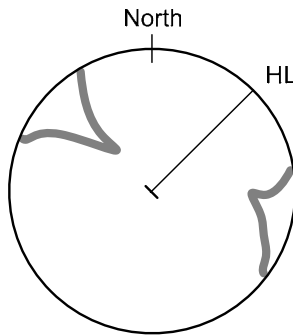

North-up mode

■ Course-up Bearing Mode

By pressing the soft key 3, the own ship's course is fixed pointing to the zenith of the PPI (0° on range rings) points to the due north. In the same way as in the North-up mode, fixed targets do not flicker, and are stabilized even if the ship is yawing. The bearing of the heading line varies by the same shift of own ship's course. To change the course, press the soft key 3 several times to select the Course-up mode, and set a new course.

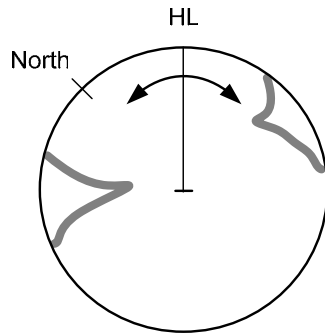

Course-up mode

2.7.14 SELECTING TRANSMITTER PULSE LENGTH

Switches the transmitter pulse length.

- 1 Select Pulse Length on the soft key menu.

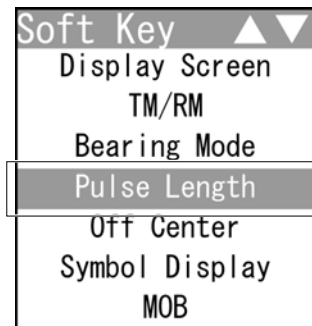

"Pulse Length" is color-inverted.

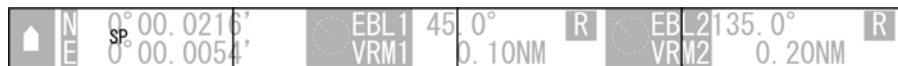

The "Pulse Length" soft key display appears.

- 2 Operate with the soft keys.

Soft key 1: SP MP1 MP2 LP1 LP2

The transmitter pulse length is switched.

Press the soft key 1 to change the setting in order of:

"SP" → "MP1" → "MP2" → "LP1" → "LP2".

Reference:

Options of the transmitter pulse length vary depending on the range.
For details, see "7.2 SCANNER".

Soft key 2: Not available

Soft key 3: Not available

Soft key 4: Not available

■ **Effects of transmitter pulse length**

● **SP** :

The transmitter pulse length becomes shorter, and the range resolution improves.

The effect of suppressing sea clutter returns and rain/snow clutter returns heightens.

Recommended condition for selection:

In bays / harbors where targets are densely crowded

Rough sea state due to torrential rain or stormy weather

● **MP** :

The normal transmitter pulse length is set.

Both range resolution and sensitivity are appropriately set.

Recommended condition for selection:

General navigation

● **LP** :

The transmitter pulse length becomes longer, and sensitivity improves.

Small targets are zoomed and are easy to observe.

When the sea state is bad, detection performance decreases.

Recommended condition for selection:

Detection of small targets in good weather conditions

Usable transmitter pulse length varies according to the type of scanner unit being used and the observation range being used. For usable pulse length, see the section "SCANNER" in "SPECIFICATIONS".

2.7.15 MOVING OWN SHIP'S DISPLAY POSITION

The own ship's position can be moved from the display center to any position within 66% of the display radius.

This function is convenient for observing a wide coverage in any direction.

- 1 Select on the soft key menu.

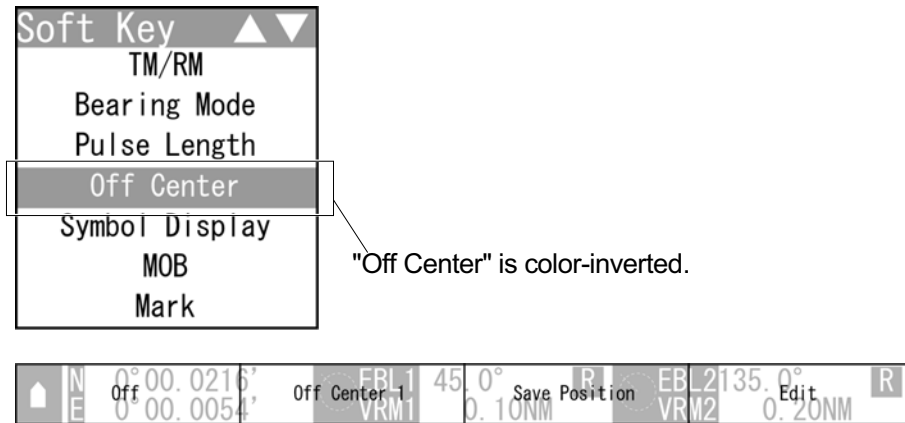

The "Off Center" soft key display appears.

- 2 Operate with the soft keys.

Soft key 1:

Turns on/off the off center function.

"Off": The own ship's position returns to the center.

"On": The cross cursor mark + will appear at the own ship's position on the radar screen.

Soft key 2:

"Off Center1": The own ship's position is moved to 66% position of the display radius.

"Off Center2": The own ship's position is moved to 44% position of the display radius.

"Off Center3": The own ship's position is moved to 22% position of the display radius.

"Custom": The own ship's position can be moved to any position.

When pressing the soft key 4, "Edit" is color-inverted.

Move the cross cursor mark + (own ship's display position) to a desired position by using the cursor keys.

Press the ENT key to fix the own ship's display position at the cross cursor mark + position.

"Load Position": The saved own ship's display position is displayed.

Soft key 3: Save Position

When "Custom" is displayed above the soft key 2, press the soft key 3 to save the current own ship's display position.

Soft key 4: Edit

When "Custom" is displayed above the soft key 2, press the soft key 4 to move the own ship's display position to any position.

2.7.16 SETTING SYMBOL DISPLAY

Displays/hides the following functions.

- TT
- AIS
- Marks/lines
- Own track

1 Select Symbol Display on the soft key menu.

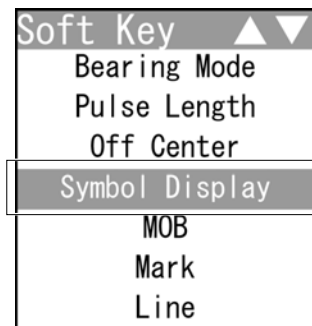

"Symbol Display" is color-inverted.

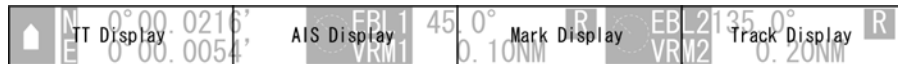

The "Symbol Display" soft key display appears.

2 Operate with the soft keys.

Soft key 1: TT Display TT Display Off

"TT Display": The TT symbols are displayed.

"TT Display Off": The TT symbols are hidden.

However, the dangerous targets are shown.

Soft key 2: AIS Display AIS Display Off

"AIS Display": The AIS symbols are displayed.

"AIS Display Off": The AIS symbols are hidden.

Soft key 3: Mark Display Mark DISP Off

"Mark Display": The marks and lines are displayed.

"Mark DISP Off": The marks and lines are hidden.

Soft key 4: Track Display Track DISP Off

"Track Display": The own track is displayed.

"Track DISP Off": The own track is hidden.

2.7.17 SETTING MOB

MOB is the mark of a person or an object overboard. If someone or something falls overboard, set MOB to memorize the latitude/longitude of the location and display the mark. Also, a straight line from the own ship to the mark is displayed.

Reference:

Bearing signal input and latitude/longitude data input are required to display MOB.

- 1 Select **MOB** on the soft key menu.

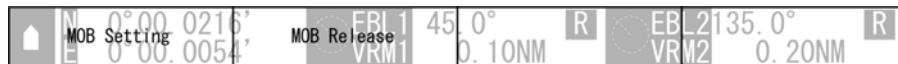
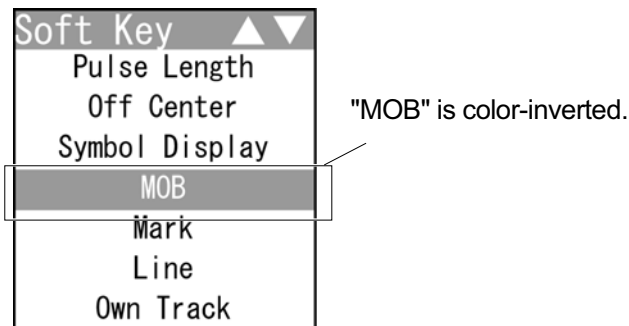

The "MOB" soft key display appears.

- 2 Operate with the soft keys.

Soft key 1: **MOB Setting**

Sets the MOB at the own ship's position.

Soft key 2: **MOB Release**

The displayed MOB is cleared.

Soft key 3: Not available

Soft key 4: Not available

2.7.18 MARKING

Marks can be indicated at arbitrary positions on the screen.

A mark created on the screen holds the latitude and longitude.

Reference:

- Bearing signal input and latitude/longitude data input are required to use marks.
- Up to 200 lines/marks can be displayed for lines, marks and event marks in total.
- When the marks are hidden in "2.7.16 SETTING SYMBOL DISPLAY", marks cannot be created.

- 1 Select **Mark** on the soft key menu.

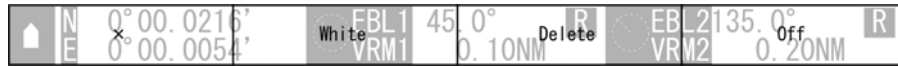
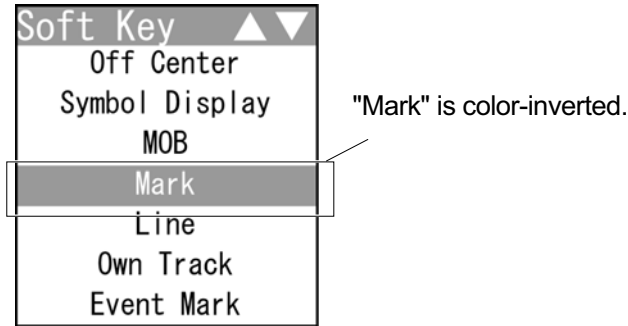

The "Mark" soft key display appears.

- 2 Operate with the soft keys.

Soft key 1: **X** **+** **Y** **⊗**

The mark type of a target is changed.

For details of size setting, see "2.17.2 SETTING MARK FUNCTIONS".

Soft key 2: **White** **Cyan** **Blue** **Green** **Yellow** **Pink** **Red**

The mark color of a target is changed.

Soft key 3: **Delete**

Press to delete the marks of selected type/color.

Hold down to delete all marks.

The confirmation dialog window is displayed.

(Marks and event marks are not distinguished when deleting.)

Soft key 4: **Off** **Enter** **Erase** **Move**

You can use the [ENT] key to create/delete/move the marks.

"Enter": Press the [ENT] key to create a mark at the cursor position.

"Erase": Press the [ENT] key to delete a mark at the cursor position.

"Move": Use the cursor to select the mark to be moved and press the [ENT] key. Then move the cursor to select the new position and press the [ENT] key to place the mark.

2.7.19 USING LINES

Lines can be indicated at arbitrary positions on the screen.

Reference:

- Bearing signal input and latitude/longitude data input are required to use lines.
- Up to 200 lines/marks can be displayed for lines, marks and event marks in total.

- 1 Select **Line** on the soft key menu.

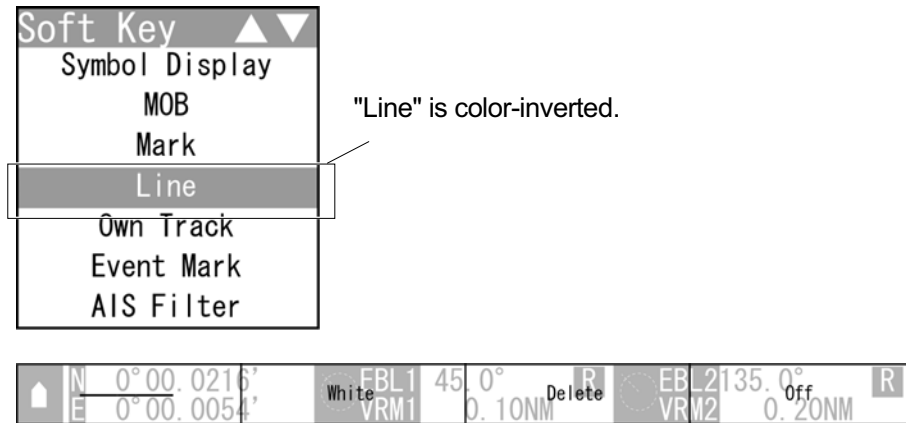

The "Line" soft key display appears.

- 2 Operate with the soft keys.

Soft key 1: **—** **---** **----**

The line type of a target is changed.

Soft key 2: **White** **Cyan** **Blue** **Green** **Yellow** **Pink** **Red**

The line color of a target is changed.

Soft key 3: **Delete**

Press to delete the lines of selected type/color.

Hold down to delete all lines.

The confirmation dialog window is displayed.

Soft key 4: **Off** **Enter** **Erase** **Move** **Insert**

You can use the [ENT] key to create/delete/move the lines.

"Enter": Press the [ENT] key to create a line at the cursor position.

"Erase": Press the [ENT] key to delete a line at the cursor position.

"Move": Use the cursor to select the line to be moved and press the [ENT] key.

Then move the cursor to select the new position and press the [ENT] key to place the line.

"Insert": Use the cursor to select the line to be inserted and press the [ENT] key.

Then move the cursor to select the position and press the [ENT] key to insert the line.

2.7.20 DISPLAYING OWN SHIP'S TRACK

The own ship's track function saves and displays own ship's track.

If navigation equipment is connected, this radar system records latitude/longitude data sent from the navigation equipment and displays own ship's track. For detail settings of own track (clearing own tracks, saved data clearing method, etc), see "2.17.4 DISPLAYING OWN SHIP'S TRACK".

Reference:

Bearing signal input and latitude/longitude data input are required to display own track.

- 1 Select on the soft key menu.

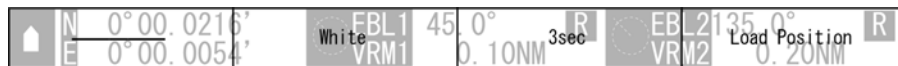
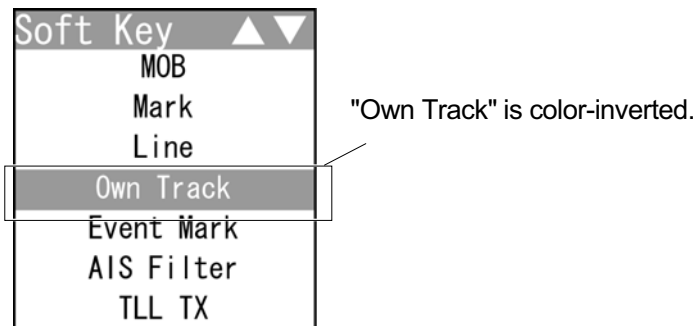

The "Own Track" soft key display appears.

- 2 Operate with the soft keys.

Soft key 1:

The line type of the own ship's track is changed.

Soft key 2:

The line color of the own ship's track is changed.

Soft key 3:

The storage interval of the own ship's track is changed.

A preset time interval or preset distance interval can be selected as the storage interval.

The distance setting varies depending on the range scale unit setting.

NM range: 1NM, 3NM, 5NM, 10NM

km range: 1km, 3km, 5km, 10km

sm range: 1sm, 3sm, 5sm, 10sm

Soft key 4:

"On": This system starts saving the position of the own ship's track.

"Off": This system stops saving the position of the own ship's track.

2.7.21 USING EVENT MARKS

Displays the event marks.

Reference:

- Bearing signal input and latitude/longitude data input are required to display event marks.
- Up to 200 lines/marks can be displayed for lines, marks and event marks in total.
- This function is initially set to off. To use this function, set this to on by referring to "■ Soft Key Menu Setting" in "4.10 Control" of the Installation Manual.

- 1 Select **Event Mark** on the soft key menu.

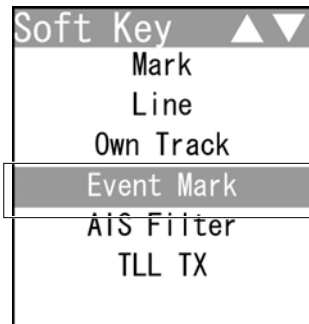

"Event Mark" is color-inverted.

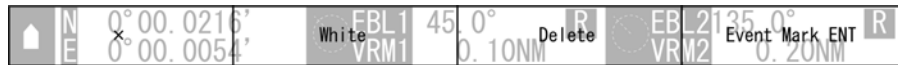

The "Event Mark" soft key display appears.

- 2 Operate with the soft keys.

Soft key 1: **X** **+** **Y** **X**

The mark type of a target is changed.

For details of size setting, see "2.17.2 SETTING MARK FUNCTIONS".

Soft key 2: **White** **Cyan** **Blue** **Green** **Yellow** **Pink** **Red**

The mark color of a target is changed.

Soft key 3: **Delete**

Press to delete the marks of selected type/color.

Hold down to delete all marks.

The confirmation dialog window is displayed.

(Marks and event marks are not distinguished when deleting.)

Soft key 4: **Event Mark ENT**

An event mark is placed at the own ship's position.

Reference:

You can easily store the event marks, such as fishing spots.

Use the cursor to enter the marks for fishing spots, a sinking ship, fish reef, etc.

2.7.22 SETTING AIS FILTER

Once the AIS filter is set, only the AIS targets that are inside the filter area are displayed (setting can be made such that AIS targets outside the AIS filter will not be shown).

The filter is initially set in a circle having a radius of 20 [NM] from the own ship's position. If 50 or more targets exist in the filter range, they are displayed according to the priority explained in "■ AIS Symbols" of Section "2.7.6 AIS OPERATIONS".

Reference:

- Bearing signal input and latitude/longitude data input are required to use AIS functions.
- This function is initially set to off. To use this function, set this to on by referring to "■ Soft Key Menu Setting" in "4.10 Control" of the Installation Manual.

- 1 Select on the soft key menu.

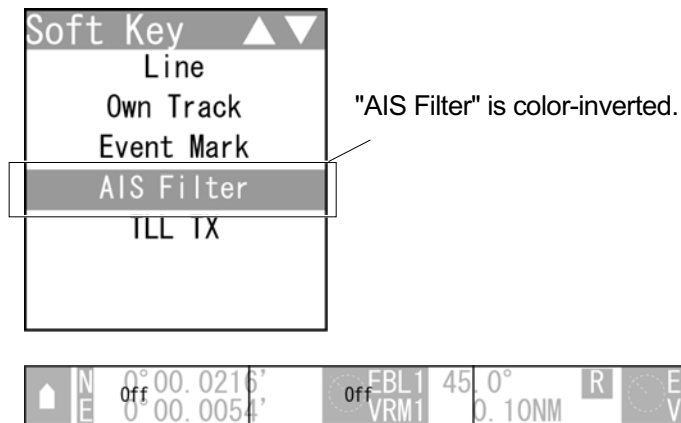

The "AIS Filter" soft key display appears.

- 2 Operate with the soft keys.

Soft key 1:

Switches between Off and Range..

"Range": A filter is set in a circle with a set range as the radius.

Soft key 2:

"Off": The filter is not displayed.

"On": The filter is displayed.

2.7.23 USING TLL TX

Reference:

This function is initially set to off. To use this function, set this to on by referring to "■ Soft Key Menu Setting" in "4.10 Control" of the Installation Manual.

Sets the TLL TX.

Transmits the TLL sentence of the cursor position on the screen to inform the mark position.

- 1 Select **TLL TX** on the soft key menu.

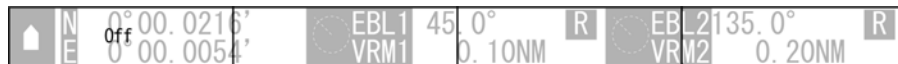
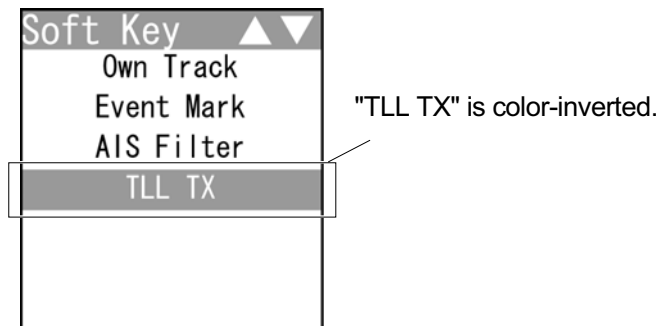

The "TLL TX" soft key display appears.

- 2 Operate with the soft keys.

Soft key 1: **Off** **TLL TX**

"Off": TLL sentence is not transmitted with the [ENT] key.

"TLL TX": TLL sentence of the cursor position is transmitted with the [ENT] key.

Soft key 2: Not available

Soft key 3: Not available

Soft key 4: Not available

2.8 BASIC MENU OPERATIONS

The settings which will not be frequently changed are called by the [MENU] key.

This section describes the operation with the MENU key.

■ Keys for operation

- [MENU] key
- Cursor keys
- [MULTI] control
- [CLEAR] key

● [CLEAR] key



Press the [CLEAR] key to return to the upper level.

■ MENU Key Operations (Example: Opening "IR")

- 1 Press the [MENU] key.

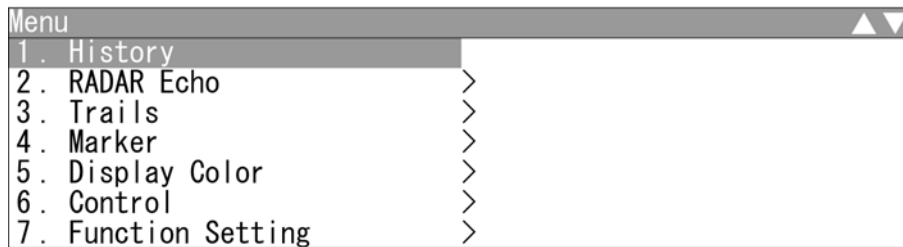

Select one of the menu items with ">" mark, then press the [ENT] key or the cursor key (right) to display the submenu.

Chapter 2 OPERATIONS
2.8 BASIC MENU OPERATIONS

- 2 Press the cursor key (down) or turn the [MULTI] control (clockwise) to select **RADAR Echo**.

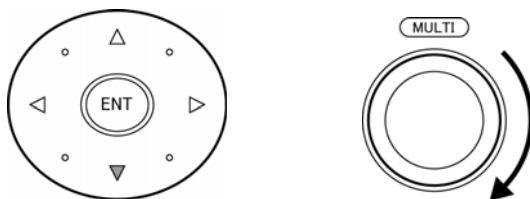

"RADAR Echo" is color-inverted.

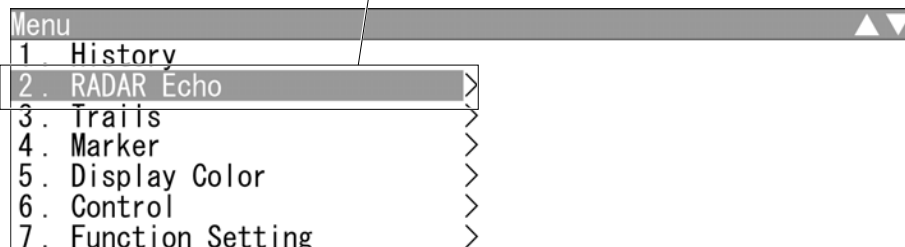

- 3 Press the [ENT] key, the cursor key (right) or the [MULTI] control.

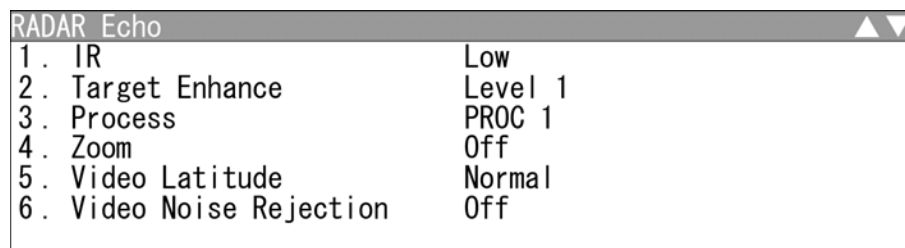
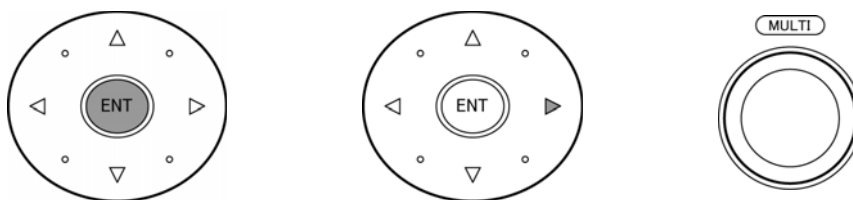

"RADAR Echo" menu appears.

Current settings are displayed on the right pane of the menu.