

Chapter 3

TRUE AND FALSE ECHOES ON DISPLAY

The radar operator has a role of interpreting the radar displays to provide his best aid in maneuvering the ship.

For this purpose, the operator has to observe the radar displays after fully understanding the advantages and disadvantages that the radar has.

For better interpretation of radar display, it is important to gain more experiences by operating the radar equipment in fair weathers and comparing the target ships watched with the naked eyes and their echoes on the radar display.

The radar is mainly used to monitor the courses of own ship and other ships in open seas, to check buoys and other nautical marks when entering a port, to measure own ship's position in the coastal waters relative to the bearings and ranges of the shore or islands using a chart, and to monitor the position and movement of a heavy rain if it appears on the radar display. Various types of radar display will be explained below.

3.1 RADAR WAVE WITH THE HORIZON

Radar beam radiation has the nature of propagating nearly along the curved surface of the earth. The propagation varies with the property of the air layer through which the radar beam propagates. In the normal propagation, the distance (D) of the radar wave to the horizon is approximately 10% longer than the distance to the optical horizon. The distance (D) is given by the following formula:

$$D=2.23(\sqrt{h_1} + \sqrt{h_2})(nm)$$

h_1 : Height (m) of radar scanner above sea level

h_2 : Height (m) of a target above sea level

Fig. 3.1-1 is a diagram for determining the maximum detection range of a target that is limited by the curve of the earth surface in the normal propagation.

Fig. 3.1-1

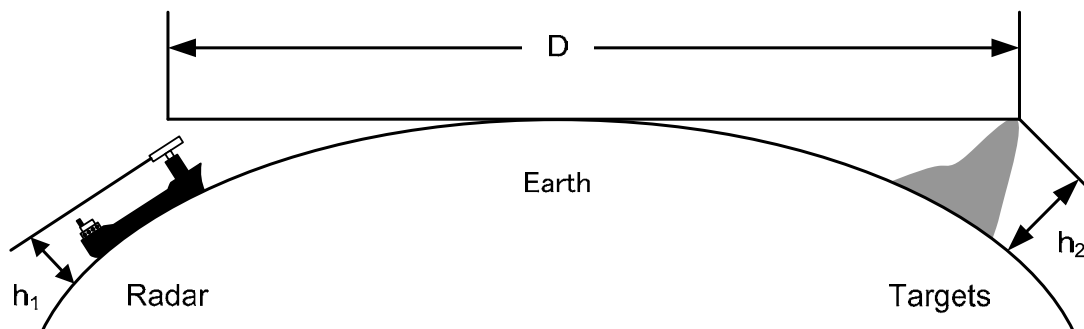

Chapter 3 TRUE AND FALSE ECHOES ON DISPLAY
3.1 RADAR WAVE WITH THE HORIZON

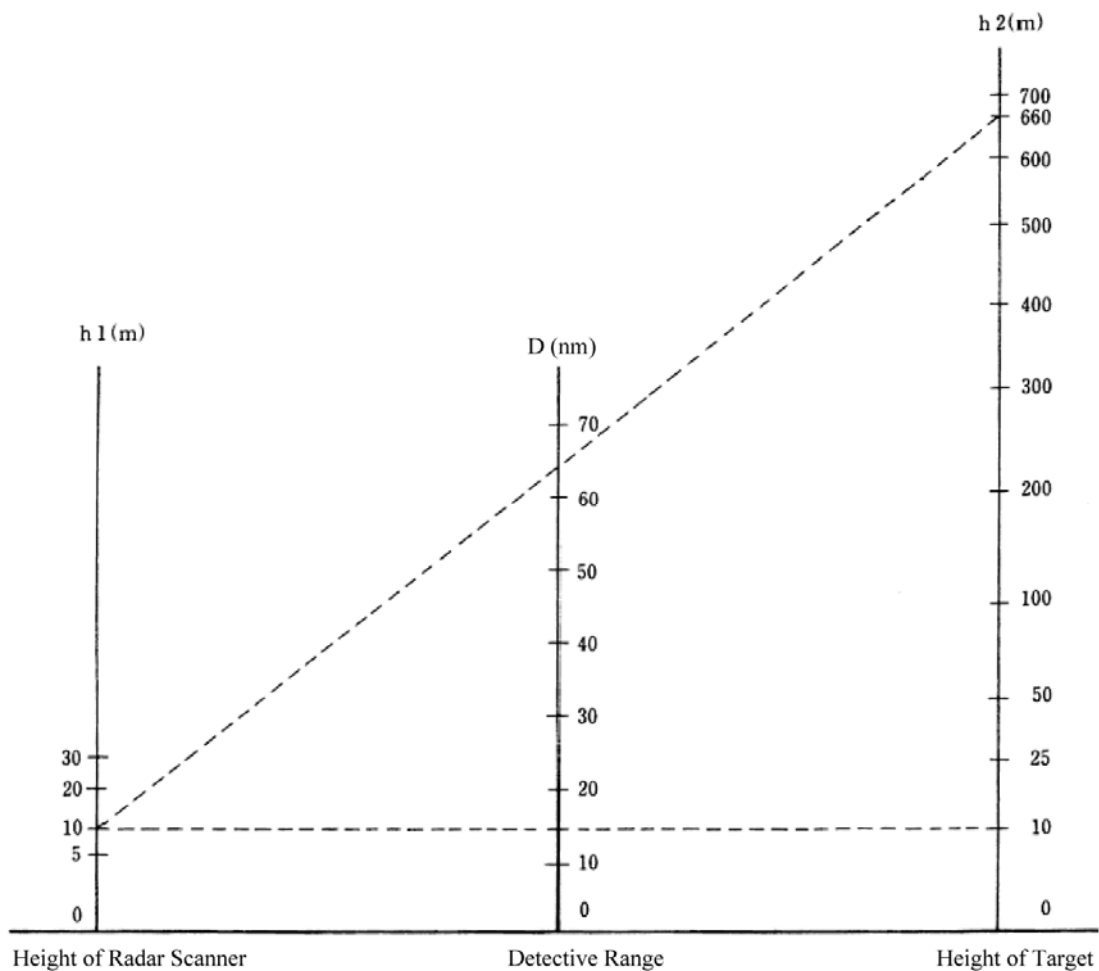

When the height of own ship's scanner is 10 m for instance,

- (a) A target that can be detected at the radar range of 64 nm on the radar display is required to have a height of 660 m or more.
- (b) If the height of a target is 10 m, the radar range has to be approx. 15 nm.

However, the maximum radar range at which a target can be detected on the radar display depends upon the size of the target and the weather conditions, that is, the radar range may increase or decrease depending upon those conditions.

3.2 REFLECTION FROM TARGET

The signal intensity reflected from a target depends not only on the height and size of the target but also on its material and shape. The echo intensity from a higher and larger target is not always higher in general.

In particular, the echo from a coast line is affected by the geographic conditions of the coast. If the coast has a very gentle slope, the echo from a mountain of the inland appears on the radar display, as shown in Fig. 3.2-1. Therefore, the distance to the coast line should be measured carefully.

Fig. 3.2-1

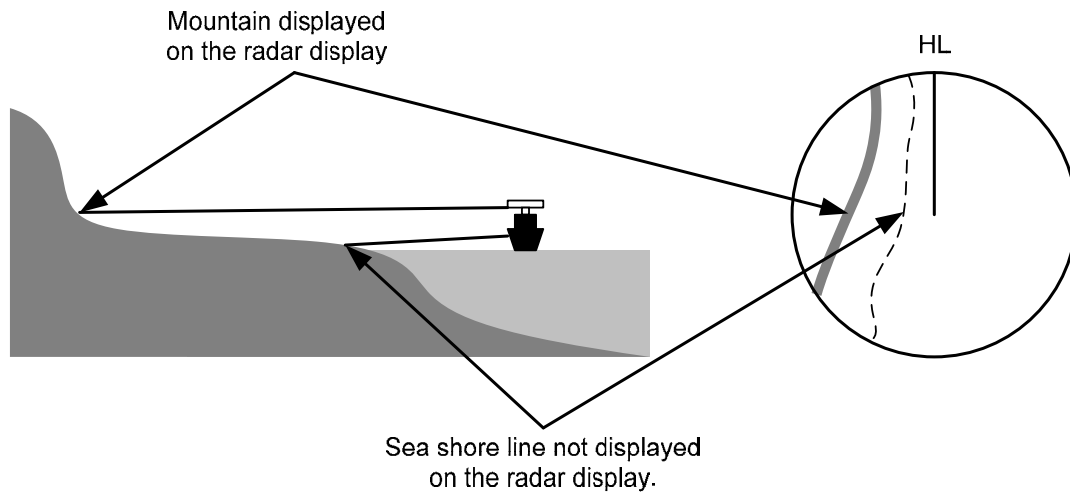

3.3 SEA CLUTTER AND RAIN AND SNOW CLUTTER

In addition to the echo required for observing ships and land radar video image also includes unnecessary echo, such as reflection from waves on the sea surface and reflection from rain and snow. Reflection from the sea surface is called "sea clutter," and reflection from rain and snow is called "rain and snow clutter," and those spurious waves must be eliminated by the clutter rejection function.

3.3.1 SEA CLUTTER

Sea clutter appears as an image radiating outwardly from the center of the radar display and changing depending on the size and the shape of waves. Generally, as waves become larger, image level of the sea clutter is intensified and the clutter far away is also displayed. When waves are large and the sea clutter level is high, it is difficult to distinguish sea clutter from a small boat whose reflection intensity is weak.

3.3.2 RAIN AND SNOW CLUTTER

Rain and snow clutter is a video image that appears in a location where rain or snow is falling. The image changes according to the amount of rain (or the amount of snowfall). As precipitation increases, the image of rain and snow clutter becomes intensified on the radar display, and in the case of localized heavy rain, an image similar to the image indicating land is displayed in some cases. Furthermore, because radio waves tend to attenuate due to rain and snow, the ability to detect a target in the rain and snow clutter or a target beyond the rain and snow clutter may decrease.

3.3.3 COPING WITH SEA CLUTTER AND RAIN AND SNOW CLUTTER

When the weather is bad and the ocean is rough, reducing the pulse width will reduce the influence by spurious waves, and also the spurious wave rejection function effectively works; therefore, the use of short pulse is effective when the weather is bad. By using image processing functions "3Scan COREL" to "5Scan COREL", it is expected that spurious waves are further suppressed. Since optimal settings for those items can be automatically made by using the function mode, it is recommended that STORM or RAIN be used by selecting the function mode when the weather is bad. For details of the function mode, see Section "2.14 FUNCTION KEY SETTINGS".

However, these functions may make some targets invisible, particularly targets with higher speeds.

3.4 FALSE ECHOES

The radar observer may be embarrassed with some echoes that do not exist actually. These false echoes appear by the following causes that are well known:

3.4.1 SHADOW

When the radar scanner is installed near a funnel or mast, the echo of a target that exists in the direction of the funnel or mast cannot appear on the radar display because the radar beam is reflected on the funnel or mast. Whether there are some false echoes due to shadows can be checked monitoring the sea clutter returns, in which there may be a part of weak or no returns. Such shadows appear always in the same directions, which the operator should have in mind in radar operation.

3.4.2 SIDE LOBE EFFECT

A broken-line circular arc may appear at the same range as the main lobe of the radar beam on the radar display. This type of false echo can easily be discriminated when a target echo appears isolated. (See Fig. 3.4-1.)

Fig. 3.4-1

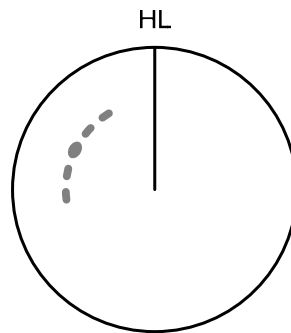

3.4.3 FALSE ECHO BY SECONDARY REFLECTION

When a target exists near own ship, two echoes from the single target may appear on the radar display.

One of those echoes is the direct echo return from the target and the other is the secondary reflection return from a mast or funnel that stands in the same direction as shown in Fig. 3.4-2.

Fig. 3.4-2

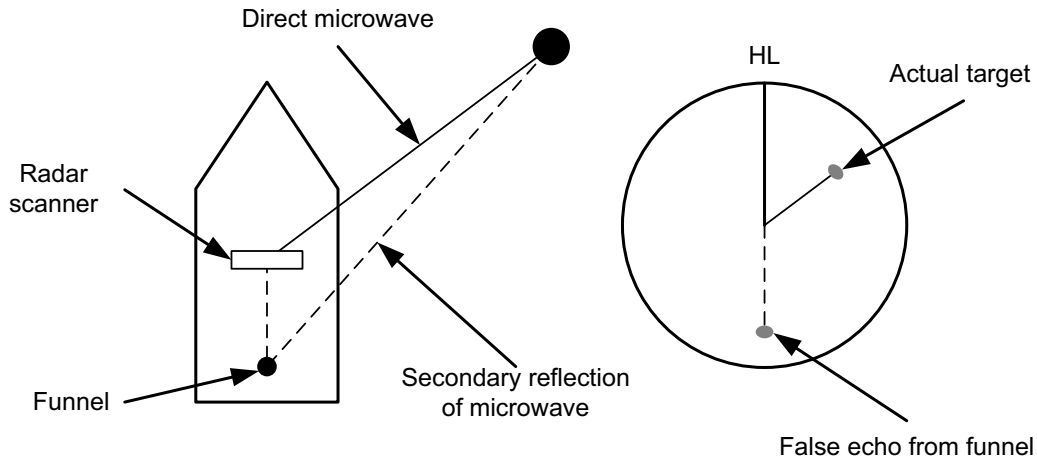

3.4.4 FALSE ECHO BY MULTIPLE REFLECTION

When there is a large structure or ship with a high vertical surface near own ship as shown in Fig. 3.4-3, multiple reflection returns may appear on the radar display. These echoes appear in the same intervals, of which the nearest echo is the true echo of the target.

Fig. 3.4-3

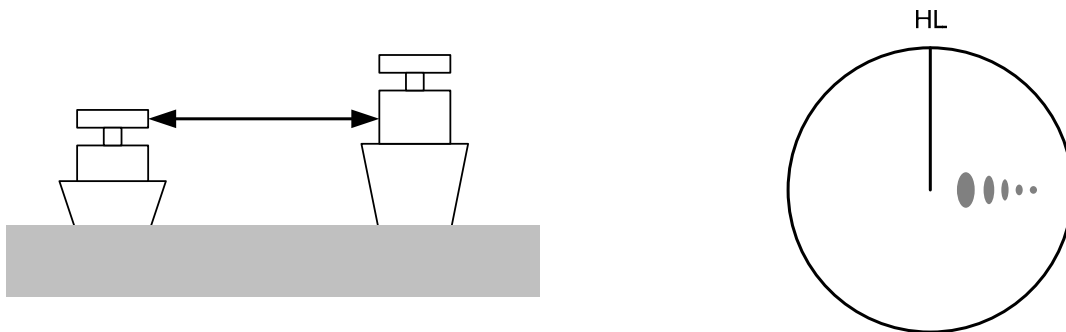

3.4.5 SECOND TIME ECHOES

The maximum radar detection range depends upon the height of the scanner and the height of a target as described in the Section "3.1 RADAR WAVE WITH THE HORIZON". If a so-called "duct" occurs on the sea surface due to a certain weather condition, however, the radar beam may propagate to an abnormally long distance, at which a target may be detected by the radar.

For instance, assuming that the pulse length is MP3 (on the repetition frequency of 1400 Hz), the first pulse is reflected from a target at about 58 NM or more and received during the next pulse repetition time. In this case, a false echo (second time echo) appears at a position that is about 58 NM shorter than the actual distance. If the false echo appears at 5 NM on the radar display, the true distance of the target is $5+58=63$ NM. On the pulse

length is SP1 (on the repetition frequency of 2250 Hz), a false echo may appear at a position that is about 36 NM shorter than the actual distance.

This type of false echo can be discriminated by changing over the range scale (the repetition frequency), because the distance of the target changes accordingly.

If second time echo is appeared, the use of Economy mode in PRF menu is effective. Otherwise, Stagger Trigger menu set to on. (Refer to Section "4.6 SCANNER" of INSTALLATION MANUAL.)

3.4.6 RADAR INTERFERENCE

When another radar equipment using the same frequency band as that on own ship is near own ship, a radar interference pattern may appear on the radar display. This interference pattern consists of a number of spots which appear in various forms. In many cases, these spots do not always appear at the same places, so that they can be discriminated from the target echoes.(See Fig. 3.4-4.)

Fig. 3.4-4

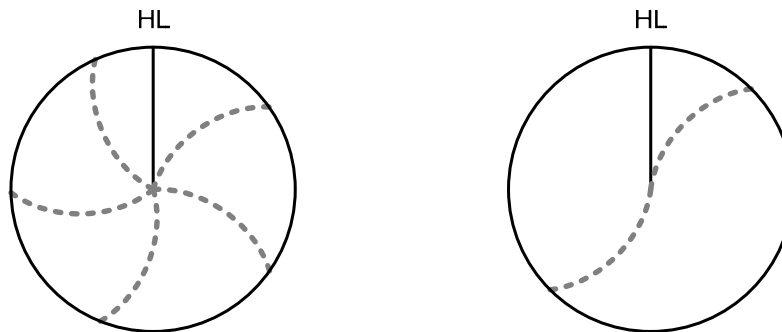

If radar equipment causing an interference pattern and this radar are of the same model, their transmitting repetition frequency is nearly the same. As a result, interference patterns may be displayed concentrically.

In this case, the interference patterns cannot be eliminated by using only the interference reflector function, so press the [TX/PRF] key several times to fine-tune the transmitting repetition frequency.

An interference suppressing effect can be heightened by applying a different transmitting repetition frequency to the interference pattern source radar and this radar.

3.5 DISPLAY OF RADAR TRANSPONDER (SART)

The SART (Search and rescue Radar Transponder) is a survival device authorized by the GMDSS (Global Maritime Distress and Safety System), which is used for locating survivors in case that a distress accident occurs at sea. The SART is designed to operate in the 9 GHz frequency band. When receiving the 9 GHz radar signal (interrogating signal) transmitted from the radar equipment on a rescue ship or search aircraft, the SART transmit a series of response signals to inform the distress position to the rescue and search party.

Perform the following settings to display SART on the radar screen.

1. Range: 6 NM or 12 NM
2. [SEA] control: Turning to the minimum position (counterclockwise fully)
3. Automatic sea clutter suppression function: Off
4. Tuning function: Off (for less clutter)
5. IR: Off
6. Processing: Off

Note:





- When performing the settings 1 to 6 above to display the SART signal, targets around own ship will disappear from the radar display. So it is necessary to exercise full surveillance over the conditions around own ship by visual watch in order to avoid any collision or stranding.

If two or more sets of radar equipment are installed on own ship, use one set of 9 GHz band radar for detection of the SART signal and operate others as normal radars for avoiding collision, monitoring targets around own ship, and checking on own ship's position and avoidance of stranding.

After the detection of SART signal, the radar adjustment is required for general navigation.

Chapter 4 MAINTENANCE

4.1 ROUTINE MAINTENANCE

 DANGER	
	<p>Never carry out internal inspection or repair work of the equipment by users. Inspection or repair work by unauthorized personnel may result in fire hazard or electric shock. For inspection and repair work of equipment components, consult with our branch office, branch shop, sales office, or our distributor in your district.</p>
	<p>When conducting maintenance, make sure to turn the main power off. Failure to comply may result in electrocution.</p>
	<p>Turn off the main power before cleaning the equipment. Especially when a rectifier is used, make sure to turn it off since voltage is still outputted from the rectifier even after the indicator and the radar are turned off. Failure to comply may result in equipment failure, or death or serious injury due to electric shock.</p>

For operating the radar equipment in the good conditions, it is necessary to make the maintenance work as described below. If maintenance is made properly, troubles will reduce. It is recommended to make regular maintenance work.





Common points of maintenance for each unit are as follow:

Clean the equipment.

Remove the dust, dirt, and sea water rest on the equipment cabinet with a piece of dry cloth. Especially, clean the air vents with a brush for good ventilation.

4.2 MAINTENANCE ON EACH UNIT

4.2.1 SCANNER UNIT NKE-2042, 2043, 2062/HS, 2063/HS, 2103-4/4HS/6/6HS

 DANGER	
	When conducting maintenance work on the antenna, make sure to turn its main power off. Failure to comply may result in electrocution or injuries.
	Make sure to turn off the antenna operation switch. Failure to comply may result in injuries caused by physical contact with the rotating antenna.
	Do not touch the radiator. Even if the power is turned off, the radiator may be rotated by the wind.

After the work, turn "ON" the scanner unit safety switch.

■ Precautions in Mounting the Cover

When the cover is removed for regular checkup and replacement of parts and refitted after such work, the procedures of fastening bolts shall be taken with the following precautions:

- The proper fastening torque of the fitting bolts (M8) is 1176 to 1470 N•cm (120 to 150kgf•cm) (which makes the inside water-tight and protects the packings against permanent compressive strain). The packings start producing from the cover at a torque of approximately 1470N•cm (150kgf•cm). Do not fasten the bolts with a torque exceeding the specified value. Otherwise, the screws may be broken.
- Use an offset wrench of 11 mm × 13 mm or a double-ended wrench of 13 mm × 17 mm (not longer than 200 mm).
- Screw all the bolts by hand first to prevent them playing, then fasten them evenly in order not to cause one-sided fastening. (Fasten the bolts with 25% of the required torque at the first step.)

*: Fasten the bolts in the diagonal order.

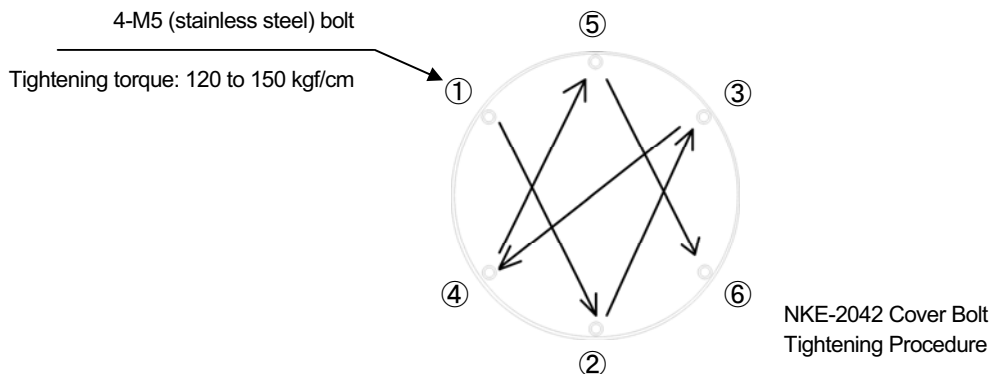

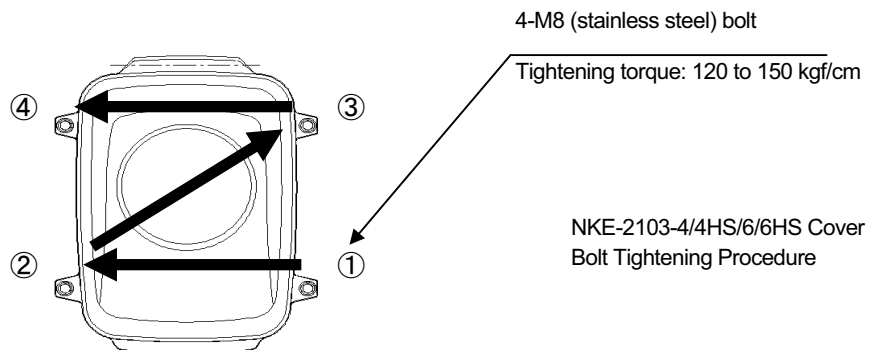
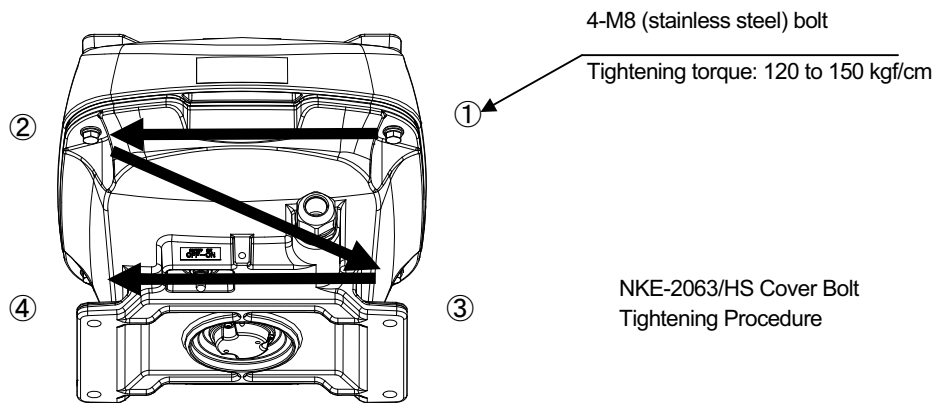
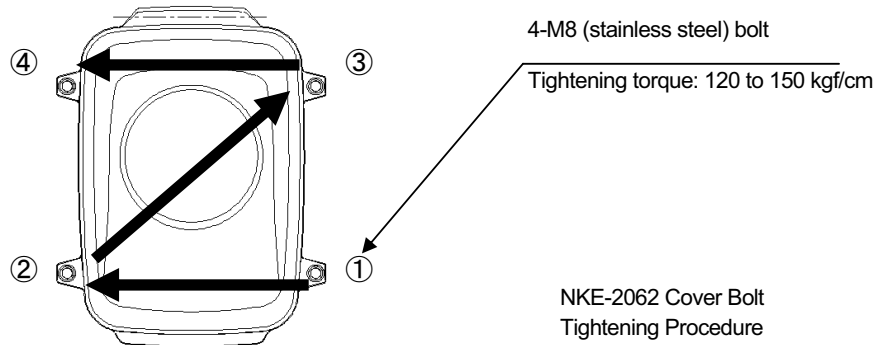
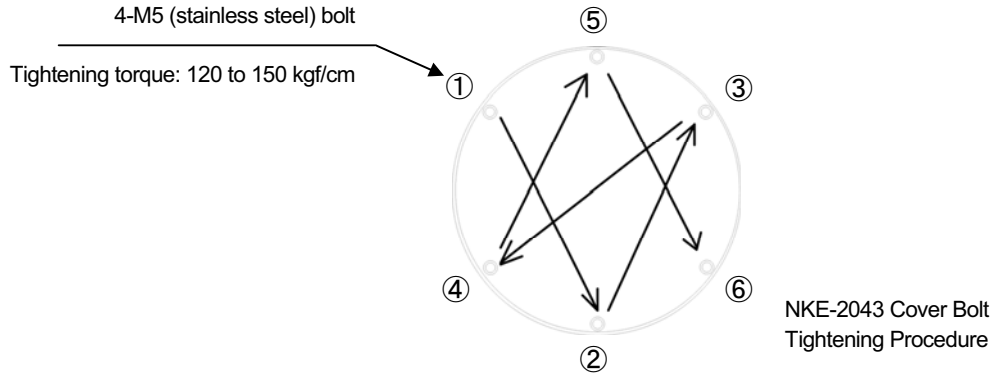

■ Radiator

Note:

- If the radiator front face (radiation plane) is soiled with smoke, salt, dust, paint or birds' droppings, wipe it with a piece of soft cloth wetted with alcohol or water and try to keep it clean at all times. Otherwise, radar beam radiation may attenuate or reflect on it, resulting in deterioration of radar performance.
- Never use solvents of gasoline, benzine, trichloroethylene and ketone for cleaning. Otherwise, the radiation plane may deteriorate.

Check up and clean the radiator.

■ Rotating section

Oiling gears

Apply grease evenly to the tooth surfaces of the main shaft drive gear and the encoder drive gear with a spreader or brush. Oiling in short intervals is more effective to prevent the gears from wear and tear and extend their service life, but oil at least every six months.

Use the grease of Mobilux 2 of Mobil Oil.

Driving motor

i) Attenuator

Greasing is not necessary unless there is oil leakage.

ii) Motor

The life span of the brush itself is 2000 hours. When the brush is worn out to a half of the entire length, replace it.

The communicator must be kept clean all the time. If carbon dust is stuck and cannot be removed with a dry cloth, polish the section with sand paper of No.150 to 400.

The carbon brush can be removed by removing the caps on both sides of the bottom of the motor.

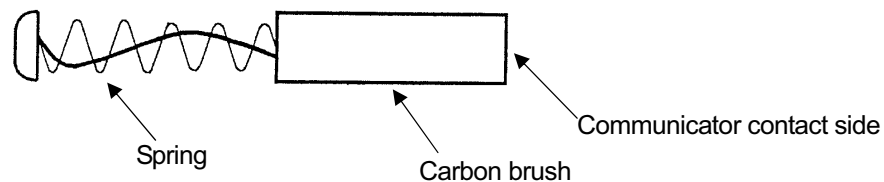



Table 4.2-1 List of replacement carbon brushes

Scanner unit model name	Item name	Model name	JRC code	Replacement quantity
JMA-3316	Carbon brush	54531-01	BRXP05247	2
JMA-3336	Carbon brush	54531-01	BRXP05247	2

Mounting legs

Check the mounting legs and mounting bolts of the scanner unit case for corrosion at intervals and maintain them to prevent danger. Apply paint to them once a half year because painting is the best measure against corrosion.

4.2.2 DISPLAY UNIT NCD-2182

 WARNING	
	<p>When cleaning the display screen, do not wipe it too strongly with a dry cloth. Also, do not use gasoline or thinner to clean the screen.</p> <p>Failure to comply will result in damage to the screen surface.</p>

Dust accumulated on the screen will reduce clarity and darken the video.

For cleaning it, wipe it with a piece of soft cloth (flannel or cotton). Do not wipe it strongly with a piece of dry cloth nor use gasoline or thinner.

4.3 PERFORMANCE CHECK

Make operational check on the radar equipment regularly and if any problem is found, investigate it immediately.

Pay special attention to the high voltage sections in checking and take full care that no trouble is caused by any error or carelessness in measurement. Take note of the results of checking, which can be used effectively in the next check work.

Operational check shall be made in accordance with Table 4.3-1 Function Check List in the order as specified in it.

Table 4.3-1 Function Check List

Equipment	Item to be checked	Criteria	Remarks
Transmitter-receiver Unit	Tuning LED of Receiver	The LED is lighting during operation	48NM range
Display Unit	Video and echoes on the screen Sensitivity LCD brilliance can be controlled correctly Various markers Various numerical indications Lighting	Can be correctly controlled	
	Safety Switch Various Currents and Voltages	See "■ Sensor Test" in "4.3.8 SELF TEST".	
	Communication Lines	See "■ Line Test" in "4.3.8 SELF TEST".	
	Memory	See "■ Memory Test" in "4.3.8 SELF TEST".	
	Panel	See "■ Key Test" in "4.3.8 SELF TEST".	
	Checking the Monitor	See "■ Monitor Display Test" in "4.3.8 SELF TEST".	
	Magnetron Current	See "4.3.4 SCANNER INFORMATION".	
	Error Logging Display	See 4.3.6 ERROR LOG.	
	System Information Display	See 4.3.2 SYSTEM INFORMATION and 4.3.3 SYSTEM TIME.	

4.3.1 TEST MENU

The performance status of this radar equipment can be checked on the Test Menu.

■ "Test" operations

- 1 Open **Test** from the Main Menu.

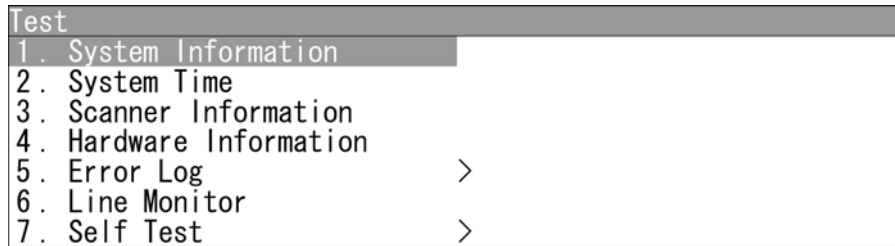

"Test" menu appears.

4.3.2 SYSTEM INFORMATION

Displays the current system information (software version information).

■ "System INFO" operations

- 1 Open **Test** - **System Information**.

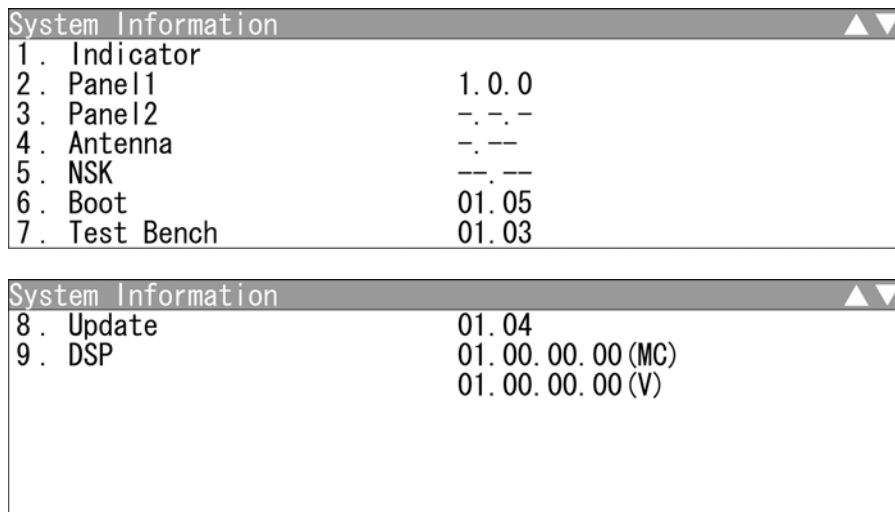

The software version is displayed.

4.3.3 SYSTEM TIME

Displays the following system time information.

- Indicator Running Time
- Scanner Transmit Time
- Scanner Motor Time
- Scanner Running Time

■ "System Time" operations

- 1 Open **Test** - **System Time**.

```
System Time
1. Indicator Running Time    1hour
2. Scanner Transmit Time    1hour
3. Scanner Motor Time       1hour
4. Scanner Running Time     1hour
```

"System Time" menu appears.

4.3.4 SCANNER INFORMATION

Displays the following scanner information.

- Transmitted output power
- Motor Type
- Magnetron Current

■ "Scanner Information" operations

- 1 Open **Test** - **Scanner INFO**.

```
Scanner Information
1. Scanner Transmit Power  -----
2. Motor Type              -----
3. Magnetron Current

                               [ ] [ ] [ ] [ ] [ ] [ ] [ ] [ ] [ ] [ ]
                               [ ] [ ] [ ] [ ] [ ] [ ] [ ] [ ] [ ] [ ]
                               0
```

"Scanner Information" menu appears.

4.3.5 HARDWARE INFORMATION

Displays the following hardware information.

- Serial Number
- MAC Address
- Temperature

■ "Hardware Information" operations

- 1 Open **Test** - **Hardware Information**.

Hardware Information	
1. Serial Number	
2. MAC Address	
3. Temperature	51.0°C
4. Monitor Brilliance	511

"Hardware Information" menu appears.

4.3.6 ERROR LOG

The error log displays previously occurred system alarms with the dates and times when they occurred.

■ "Error Log" operations

- 1 Open **Test** - **Error Log**.

Error Log	
1. Display	
2. Erase	

"Error Log" menu appears.

■ Displaying Error Log

- 1 Open - .

Error Log					
No.	Date	Time	COND	Alarm	
1.	2010-11-29	10:22:00	0000000001	OCCR	GPS Port
2.	2010-11-29	10:22:30	0000000002	RCVR	GPS Port
3.	2010-11-29	10:30:12	0000000040	OCCR	Heading (Time Out)
4.	2010-11-29	10:30:30	0000000042	RCVR	Heading (Time Out)

"Error Log" menu appears.

For details of alarms, refer to "4.5.1 LIST OF ALARMS AND OTHER INDICATIONS".

■ Erasing Error Log

- 1 Open - .

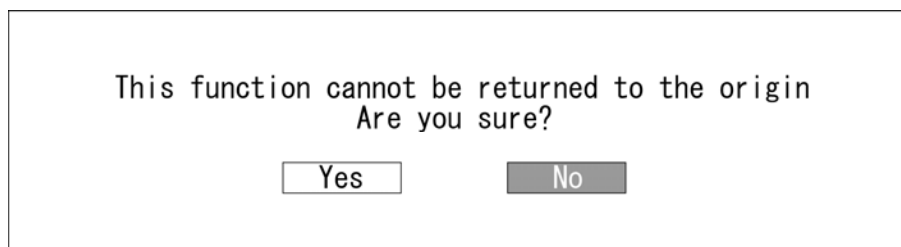

: Erases the error log.

: Does not erase the error log.

4.3.7 LINE MONITOR

Serial communication data can be seen on the built-in Line monitor.

Line monitor can be used to make sure that the serial data are received properly.

■ "Line Monitor" operations

- 1 Open - .

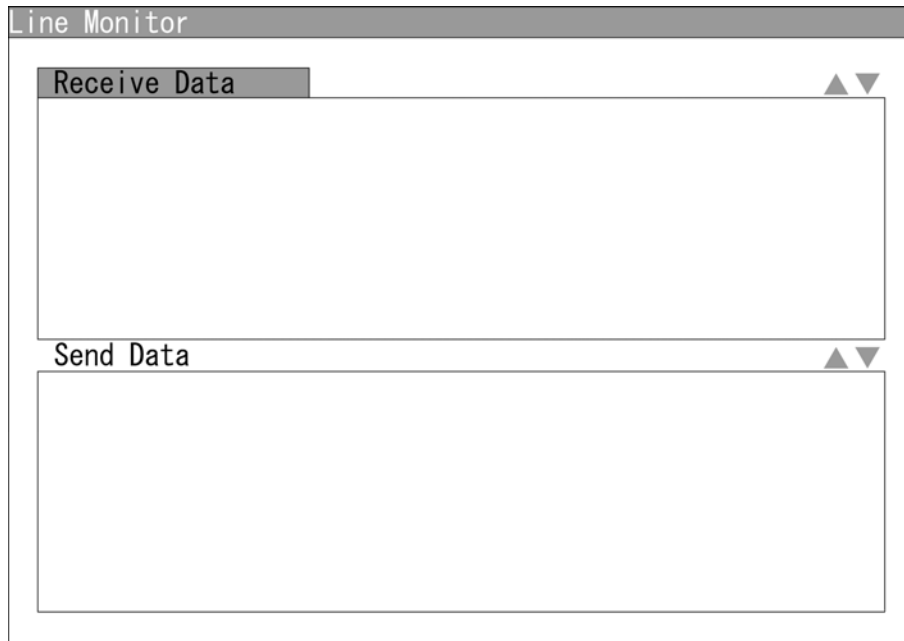

"Line Monitor" menu appears.

Receive Data: The received serial communication data are displayed.

Send Data: The transmitted serial communication data are displayed.

Soft key 1:

Press the soft key 1 to select the port for serial communication data.

Soft key 2:

Press the soft key 2 to switch the display.

Soft key 3:

Press the soft key 3 to stop/start scrolling.

Soft key 4:

Press the soft key 4 to clear all listed serial communication data.

4.3.8 SELF TEST

The following tests can be performed.

- Key Test
- Buzzer Test
- Key Light Test
- Monitor Display Test
- Memory Test
- Line Test
- Sensor Test

■ "Self Test" operations

- 1 Open - .

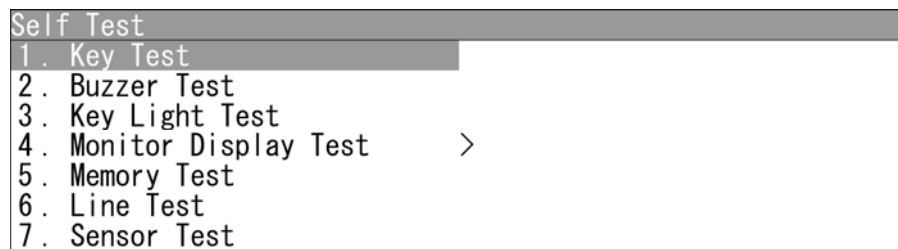

■ Key Test

- 1 Open [Self Test] - [Key Test].

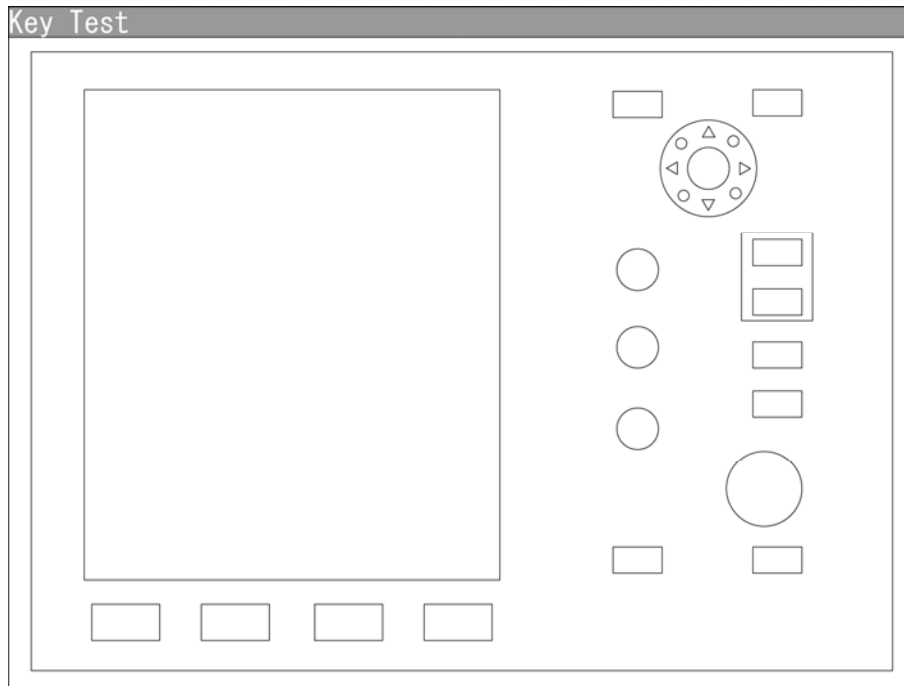

Operation key video will be displayed.

When pressing each key, the corresponding operation key is color-inverted on the display.

Press the [CLEAR] key to turn off the operation keys.

■ Buzzer Test

- 1 Open [Self Test] - [Buzzer Test].

The buzzer will sound.

The buzzer automatically stops after it sounds for a certain time.

The buzzer will sound regardless of the buzzer setting.

■ Key Light Test

- 1 Open [Self Test] - [Key Light Test].

The brightness of the operation panel is gradually intensified.

■ Monitor Display Test

- 1 Open [Self Test] - [Monitor Display Test].

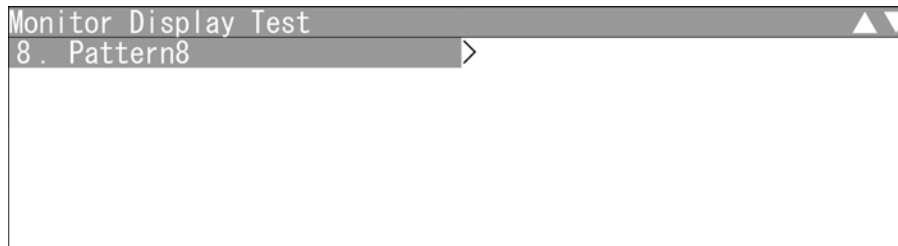

- Pattern1** : All colors are filled with white.
- Pattern2** : A white box is displayed on the black background of 1024 × 768 dots.
- Pattern3** : Displays rectangle × 2, circle × 2, and cross-shape × 9 (white lines on the black background).
- Pattern4** : Displays "H" of 9 dots × 9 dots on the entire screen (white character on the black background).
- Pattern5** : Gray scale display (16 levels)
- Pattern6** : Displays a color bar.
- Pattern7** : The square figure of a specified RGB value is shown at the center of the display.

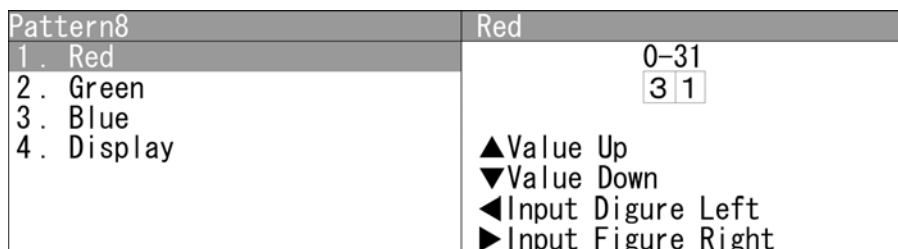
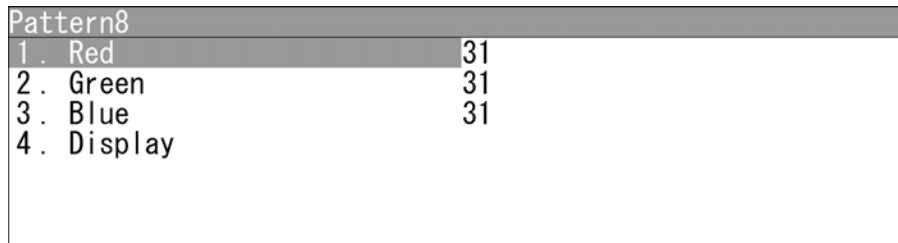

Input the value.
Turn the [MULTI] control to set the value.
The value can be set between 0 and 31.

Operate the same way for the other settings.

■ Memory Test

- 1 Open - .

Memory Test	
1. SDRAM	OK
2. Flash ROM	OK
3. USB	OK

When no abnormality is found, "OK" is displayed. When an abnormality is found, "NG" is displayed.

Reference:

More time may be required for USB detection in order to acquire "OK".
Do not remove USB during memory test.

■ Line Test

- 1 Open - .

Line Test	
1. Scanner	OK
2. Gyro	OK
3. Compass	OK
4. GPS Port	OK
5. NMEA1 Port	OK
6. Gyro/Compass Port	OK
7. NMEA2 Port	OK

Line Test	
1. Keyboard Port	OK
2. Scanner Port	OK
	OK

When no abnormality is found, "OK" is displayed. When an abnormality is found, "NG" is displayed.

■ Sensor Test



1 Open - .





Sensor Test	
1. SSW Off	OK
2. AZI	OK
3. HL	OK
4. MHV	OK
5. Trigger	OK
6. Video	OK

When no abnormality is found, "OK" is displayed. When an abnormality is found, "NG" is displayed.

4.4 REPLACEMENT OF MAJOR PARTS

The system includes parts that need periodic replacement. The parts should be replaced as scheduled. Use of parts over their service life can cause a system failure.

 WARNING	
	<p>Direct exposure to electromagnetic waves at close range will have adverse effects on the human body. When it is necessary to get close to the antenna for maintenance or inspection purposes, make sure to turn the indicator power switch to "OFF" or "STBY." Direct exposure to electromagnetic waves at close range will have adverse effects on the human body.</p>
	<p>When conducting maintenance work, make sure to turn off the power and unplug the power connector J1 of the display unit so that the power supply to the equipment is completely cut off. Some equipment components can carry electrical current even after the power switch is turned off, and conducting maintenance work without unplugging the power connector may result in electrocution, equipment failure, or accidents.</p>

 CAUTION	
	<p>Make sure to shut off the main power before replacing parts. Failure to comply may result in electrocution or equipment failure.</p>
	<p>When replacing magnetrons, make sure to shut off the main power and let the equipment stand for more than 5 minutes to discharge the high-voltage circuit. Failure to comply may result in electrocution.</p>
	<p>Make sure to take off your watch when your hand must get close to the magnetron. Failure to comply may result in damage to the watch since the magnetron is a strong magnet.</p>
	<p>Do not directly touch the inverter circuit of the LCD display with a bare hand since high voltage temporarily remains in the circuit even after the main power is shut off. Failure to comply may result in electrocution.</p>

Chapter 4 MAINTENANCE
4.4 REPLACEMENT OF MAJOR PARTS

■ **Parts Required for Periodic Replacement**

Here are parts required for periodic replacement.

Part name	Interval
1. Magnetron	4,000 hours
2. Motor	10,000 hours
3. LCD backlight	50,000 hours
4. Fan motor	20,000 hours

4.5 FAULT FINDING

In case of semiconductor circuits, it is deemed that there are few cases in which the used semiconductor devices have inferior quality or performance deterioration except due to insufficient design or inspection or by other external and artificial causes. In general, the relatively many causes are disconnection in a high-value resistor due to moisture, a defective variable resistor and poor contact of a switch or relay.

Some troubles are caused by defective parts, imperfect adjustment (such as tuning adjustment) or insufficient service (such as poor cable contact). It will also be effective to check and readjust these points.

4.5.1 LIST OF ALARMS AND OTHER INDICATIONS

If any of the following alarm occurs, the system displays the alarm message in red in order to attract the attention of operator. Other messages are displayed with the suitable color which is yellow or blue depending on the level of message importance.

Alarm:	Red	• Collision-related Alarm • Navigation Alarm • System Alarm
Caution:	Yellow	• System Warning
Status:	Blue	• Operation Information

The following table shows alarms and other indications the system displays.

Table 4.5-1 Alarm list

Alarm name (Japanese)	Alarm name (English)	Class	Description
警報エラー	Alarm Error	Alarm	Cannot send the alarm because of insufficient message buffer for alarm task.

Table 4.5-2 Alarm list of system alarm: scanner

Alarm name (Japanese)	Alarm name (English)	Class	Description
空中線 安全 SW オフ	Scanner(SSW Off)	Alarm	The safety switch OFF bit of scanner communication data is set.
空中線 AZI	Scanner(AZI)	Alarm	The BP error bit of scanner communication data is set.
空中線 HL	Scanner(HL)	Alarm	The BZ error bit of scanner communication data is set.
空中線 変調高圧	Scanner(MHV)	Alarm	The high-voltage modulator error bit of scanner communication data is set.
空中線 無通信	Scanner(Time Out)	Alarm	No reply from the scanner after data transmission.

Chapter 4 MAINTENANCE

4.5 FAULT FINDING

Alarm name (Japanese)	Alarm name (English)	Class	Description
空中線 データ	Scanner(Data)	Alarm	Collision occurs when transmitting data to the scanner. Checksum of the received data is different.
空中線 EEPROM	Scanner(EEPROM)	Alarm	Stored value error is returned from the scanner when the initial adjustment data is requested. The save operation is not completed when data save is requested to scanner EEPROM.
空中線 ヒータ電圧	Scanner(Heater)	Alarm	The MAG heater voltage error bit of scanner communication data is set.
空中線 逆回転	Scanner(Reverse)	Alarm	The reverse rotation alarm bit of scanner communication data is set.
空中線 ビデオ	Scanner(Video)	Alarm	The VIDEO error bit of scanner communication data is set.
空中線 トリガー	Scanner(Trigger)	Alarm	The TRIGGER error bit of scanner communication data is set.
空中線 ファン1	Scanner(Fan 1)	Alarm	The FAN error bit (FAN 1) of scanner communication data is set.
空中線 ファン2	Scanner(Fan 2)	Alarm	The FAN error bit (FAN 2) of scanner communication data is set.
空中線 モータ電流	Scanner(Motor)	Alarm	The motor current error of scanner communication data is set.

Table 4.5-3 Alarm list of system alarm: display unit

Alarm name (Japanese)	Alarm name (English)	Class	Description
操作部1 無通信	Keyboard1(Time Out)	Alarm	No reply from the control panel after data transmission.
操作部2 無通信	Keyboard2(Time Out)	Alarm	No reply from the control panel after data transmission.
DSP ビデオ	DSP(Video)	Alarm	DSP detects VIDEO error.
DSP トリガー	DSP(Trigger)	Alarm	DSP cannot receive TI interrupt.
DSP AZI	DSP(AZI)	Alarm	DSP cannot receive BP interrupt.
DSP HL	DSP(HL)	Alarm	DSP cannot receive BZ interrupt.
DSP 処理異常	DSP Error	Alarm	Abnormal operation (infinite loop) of DSP.

Table 4.5-4 Alarm list of system alarm: external equipment communication

Alarm name (Japanese)	Alarm name (English)	Class	Description
GPS ポート	GPS Port	Alarm	Serial driver error occurs during COM1 port communication.
Gyro/Compass ポート	Gyro/Compass Port	Alarm	Serial driver error occurs during COM2 port communication.
NMEA1 ポート	NMEA1 Port	Alarm	Serial driver error occurs during COM3 port communication.
NMEA2 ポート	NMEA2 Port	Alarm	Serial driver error occurs during COM4 port communication.
Keyboard ポート	Keyboard Port	Alarm	Serial driver error occurs during COM5 port communication.
Scanner ポート	Scanner Port	Alarm	Serial driver error occurs during COM6 port communication.
ジャイロ 無通信	GYRO(Time Out)	Alarm	For heading equipment=Gyro, cannot receive valid sentences (including checksum error) which had been received properly.

Alarm name (Japanese)	Alarm name (English)	Class	Description
ログ 無通信	Log(Time Out)	Alarm	For speed equipment=log, cannot receive valid sentences (including checksum error) which had been received properly.
ジャイロ 通信データ	GYRO(Data)	Alarm	For heading equipment=Gyro, the GYRO error bit of NSK communication data is set.
ログ 通信データ	Log(Data)	Alarm	For speed equipment=log, the LOG error bit of NSK communication data is set.
針路 無通信	Heading(Time Out)	Alarm	For heading equipment=compass, cannot receive valid NMEA bearing sentences (including checksum error) which had been received properly.
針路 通信データ	Heading(Data)	Alarm	For heading equipment=compass, cannot receive valid NMEA bearing data which had been received properly.
2 軸対地 無通信	2AXG(Time Out)	Alarm	For speed equipment=2-axis log, cannot receive valid VBW sentences (including checksum error) which had been received properly.
2 軸対地 通信データ	2AXG(Data)	Alarm	For speed equipment=2-axis log, cannot receive valid VBW ground data which had been received properly.
GPS エラー	GPS(Error)	Status	Failed to set GPS.
GPS 無通信	GPS(Time Out)	Alarm	Cannot receive valid GPS sentences (including checksum error) which had been received properly.
GPS 位置データ	GPS(Position)	Alarm	Cannot receive valid position data which had been received properly
GPS 測地系データ	GPS(Datum)	Alarm	Cannot receive valid geodetic data which had been received properly
GPS 速度データ	GPS(Speed)	Alarm	For speed equipment=GPS, cannot receive valid speed data which had been received properly
GPS 測位状態	GPS(Status)	Alarm	Received GPS fixing status error (invalid) data
水深 無通信	Depth(Time Out)	Alarm	Cannot receive valid depth sentences (including checksum error) which had been received properly
水深 通信データ	Depth(Data)	Alarm	Cannot receive valid depth data which had been received properly
水温 無通信	TEMP(Time Out)	Alarm	Cannot receive valid water temperature sentences which had been received properly
水温 通信データ	TEMP(Data)	Alarm	Cannot receive valid water temperature data which had been received properly
風向風速 無通信	Wind(Time Out)	Alarm	Cannot receive valid wind direction/wind velocity sentences (including checksum error) which had been received properly
風向風速 (真) 通信データ	Wind True(Data)	Alarm	Cannot receive valid water temperature data after valid wind direction/wind velocity (true) data had been received properly

Chapter 4 MAINTENANCE

4.5 FAULT FINDING

Alarm name (Japanese)	Alarm name (English)	Class	Description
風向風速 (相) 通信データ	Wind Relative(Data)	Alarm	Cannot receive valid water temperature data after valid wind direction/wind velocity (relative) data had been received properly
回頭率 無通信	Turn(Time Out)	Alarm	Cannot receive valid turning ratio sentences (including checksum error) which had been received properly
回頭率 通信データ	Turn(Data)	Alarm	Cannot receive valid turning ratio data which had been received properly
舵角 無通信	Rudder(Time Out)	Alarm	Cannot receive valid steering direction sentences (including checksum error) which had been received properly
舵角 通信データ	Rudder(Data)	Alarm	Cannot receive valid steering direction data which had been received properly
AIS 無通信	AIS(Time Out)	Alarm	For AIS function=On, cannot receive valid AIS data (including checksum error) which had been received properly
AIS 通信データ	AIS(Data)	Alarm	For AIS function=On, cannot receive valid AIS data which had been received properly
AIS アラーム 001	AIS(Alarm 001)	Alarm	For AIS function=On, an error from the AIS receiver is received (ALR)
AIS アラーム 002	AIS(Alarm 002)	Alarm	For AIS function=On, an error from the AIS receiver is received (ALR)
AIS アラーム 003	AIS(Alarm 003)	Alarm	For AIS function=On, an error from the AIS receiver is received (ALR)
AIS アラーム 004	AIS(Alarm 004)	Alarm	For AIS function=On, an error from the AIS receiver is received (ALR)
AIS アラーム 005	AIS(Alarm 005)	Alarm	For AIS function=On, an error from the AIS receiver is received (ALR)
AIS アラーム 006	AIS(Alarm 006)	Alarm	For AIS function=On, an error from the AIS receiver is received (ALR)
AIS アラーム 008	AIS(Alarm 008)	Alarm	For AIS function=On, an error from the AIS receiver is received (ALR)
AIS アラーム 025	AIS(Alarm 025)	Alarm	For AIS function=On, an error from the AIS receiver is received (ALR)
AIS アラーム 026	AIS(Alarm 026)	Alarm	For AIS function=On, an error from the AIS receiver is received (ALR)
AIS アラーム 029	AIS(Alarm 029)	Alarm	For AIS function=On, an error from the AIS receiver is received (ALR)
AIS アラーム 030	AIS(Alarm 030)	Alarm	For AIS function=On, an error from the AIS receiver is received (ALR)

Alarm name (Japanese)	Alarm name (English)	Class	Description
AIS アラーム 032	AIS(Alarm 032)	Alarm	For AIS function=On, an error from the AIS receiver is received (ALR)
AIS アラーム 035	AIS(Alarm 035)	Alarm	For AIS function=On, an error from the AIS receiver is received (ALR)

Table 4.5-5 Notification list

Alarm name (Japanese)	Alarm name (English)	Class	Description
ジャイロ設定	Set Gyro	Status	Requires setting of true bearing.
まもなく TM リセット	TM Reset	Status	For TM, the own ship position is out of 60% of the radius of PPI.
機内温度上昇	High Temperature	Caution	Adjusting the LCD brilliance due to internal temperature control.
GPS 測位精度低下	GPS(HDOP)	Caution	Received excessive HDOP value beyond the setting.

Table 4.5-6 Radar alarm list

Alarm name (Japanese)	Alarm name (English)	Class	Description
レーダーアラーム 1 進入	Area1(Approach)	Alarm	Echo in area 1.
レーダーアラーム 2 進入	Area2(Approach)	Alarm	Echo in area 2.
レーダーアラーム 1 離脱	Area1(Secession)	Alarm	No echo in area 1
レーダーアラーム 2 離脱	Area2(Secession)	Alarm	No echo in area 2
レーダーアラーム 1 領域外	Area1(Out of Range)	Alarm	<ul style="list-style-type: none"> Rectangle area 1 is out of range Creation of area 1 is out of range
レーダーアラーム 2 領域外	Area2(Out of Range)	Alarm	<ul style="list-style-type: none"> Rectangle area 1 is out of range Creation of area 2 is out of range
TT 危険目標	TT(CPA/TCPA)	Alarm	TT is changed to a dangerous ship
TT 新規目標	TT(New Target)	Alarm	TT is automatically acquired
TT 目標ロスト	TT(Lost)	Alarm	TT is lost
TT 領域外	TT(Out of Range)	Alarm	TT is too far to be tracked
TT 最大捕捉数	TT(Max Target)	Status	Manually acquired when the number of acquisition reached maximum
TT 最大捕捉数	TT(Max Target)	Status	Detected when DSP tries to acquire 11 targets or more DSP notifies the maximum target alarm occurrence of automatic acquisition to the TT process task, then the TT process task notifies it to the alarm task
EBL1/VRM1 領域外	EBL/VRM1(Out)	Status	The floating position of EBL1/VRM1 in the latitude/longitude floating setting is out of the radius of PPI
EBL2/VRM2 領域外	EBL/VRM2(Out)	Status	The floating position of EBL2/VRM2 in the latitude/longitude floating setting is out of the radius of PPI

Chapter 4 MAINTENANCE

4.5 FAULT FINDING

Alarm name (Japanese)	Alarm name (English)	Class	Description
平行線カーソル領域外	P-CURS(Out)	Status	The floating position of the parallel cursor in the latitude/longitude floating setting is out of the radius of PPI

Table 4.5-7 Error message list and alarm list for operations

Alarm name (Japanese)	Alarm name (English)	Class	Description
方位データ無し	No Heading Data	Status	Cannot function because own ship heading is not available <ul style="list-style-type: none"> • Operations for specifying TT acquisition/numerical display • Changing to TM • Changing to N Up/C Up
プリヒート中です	On Preheating	Status	Transmission operation during preheating
操作間隔が短いです	Short Interval	Status	Transmission operation in the interval of 1 second or less between standby and transmission
エラー発生中です	Error Occurring	Status	Transmission operation during prohibition of transmission caused by scanner error
最大点数です	Max Point	Status	Exceeded the maximum number of marks
ファイル無し	File Not Found	Status	File does not exist
外部メモリ無し	USB Memory Not Set	Status	USB memory does not exist
ファイル読み込み失敗	File Read Error	Caution	Failed to load the file
ファイル書き出し失敗	File Write Error	Caution	Failed to write the file
空容量不足	Not Enough Space	Status	Insufficient capacity
フォーマット失敗	Format Error	Caution	Failed to format
ファイル数オーバー	Num of files Over	Caution	Writing data to the USB memory in which the number of the file has reached to the maximum
ファイル削除失敗	File Erase Error	Caution	Failed to delete the file
診断結果 NG	Self Test NG	Caution	Diagnosis NG
自船高緯度オーバー	LAT(Out of Bounds)	Caution	The own ship's latitude is 80 degrees or more (indicating that some functions are limited) <ul style="list-style-type: none"> • Displays AIS, waypoint, mark/line, own ship trail, etc. for 80 degrees or more • Input operations for 80 degrees or more (refer to "High Latitude" alarm)

Alarm name (Japanese)	Alarm name (English)	Class	Description
設定されていません	Unsetting	Status	<ul style="list-style-type: none"> • Menu display operations when all soft key menu/multi control menu items are turned off • Area creation operations for alarm class=Off • EBL bearing setting while EBL is off • Floating setting while EBL/VRM is off • VRM range setting while VRM is off • Bearing/width setting while parallel cursor is off • Manual tuning setting while automatic tuning is on • AIS operations while AIS function is off • TT operations while TT function is off • Operations to display the weather information while no observation point is selected
最大レンジです	MAX Range Scale	Status	Range up operations at the maximum range
最小レンジです	MIN Range Scale	Status	Range down operations at the minimum range
無効値です	Invalid Data	Status	<p>Cannot function due to invalid value</p> <ul style="list-style-type: none"> • Invalid code is input for the code input screen
操作中です	In Operation	Status	<p>This operation is disabled due to another operation</p> <ul style="list-style-type: none"> • Setting enable/disable and class during alarm area creation • Setting operations for on/off and floating position during EBL bearing setting • Setting operations for on/off and bearing during EBL floating position setting • Operations for on/off during VRM range setting • Operations for on/off, mode and saving during off center custom position setting • Operations for PRF tuning during manual tuning operations • Setting for automatic/manual mode during manual tuning operations • Operations for manual tuning during PRF tuning operation

Chapter 4 MAINTENANCE

4.5 FAULT FINDING

Alarm name (Japanese)	Alarm name (English)	Class	Description
方位/緯度経度 無し	No HDG/POSN Data	Status	<p>Cursor operations when own heading or latitude/longitude is disabled</p> <ul style="list-style-type: none"> • MOB input • Event mark input • Inputting/erasing/moving marks • Inputting/erasing/moving/inserting lines • Floating position setting for EBL latitude/longitude. • Floating position setting for VRM latitude/longitude. • Floating position setting for parallel cursor latitude/longitude • AIS numerical display/destination ship/retrieved vessel selection • Creating latitude/longitude alarm area. • TLL transmission for cursor.
できません	Not Allowed	Status	<ul style="list-style-type: none"> • Operations for inserting by selecting the end point in the line list. • Operations for switching to H-UP during TM (When heading is not available, temporarily changed to RM-HUp, therefore, message is disabled.)
設定不可なレンジです	Range Scale Limit	Status	<p>Operations functionally restricted for certain range.</p> <ul style="list-style-type: none"> • Zoom operations in range where zoom is not available. • Off center operations in range where off center is not available. • TM setting operations in range where TM setting is not available.
データがありません	No Valid Data	Status	<p>Operations without data.</p> <ul style="list-style-type: none"> • Displaying history menu without history data. • Operations for editing/erasing in the mark list while there is no mark. • Operations for editing/erasing/inserting in the line list while there is no line.

Alarm name (Japanese)	Alarm name (English)	Class	Description
スタンバイ中です	Scanner Standby	Status	<p>The functions which are available only during transmitting are operated during standby (or preheating).</p> <ul style="list-style-type: none"> Setting Timed TX to on. <p>Cursor operations during standby (no graphic display is available).</p> <ul style="list-style-type: none"> Custom position setting for off center. Inputting/erasing/moving marks Inputting/erasing/moving/inserting lines Floating position setting for EBL. Floating position setting for VRM. Floating position setting for parallel cursor. TT acquisition/release/numerical display selection. AIS numerical display/destination ship/retrieved vessel selection Alarm area creation
高緯度オーバー	High Latitude	Status	<p>Operations for the position of latitude 80 degrees or more.</p> <ul style="list-style-type: none"> MOB input Event mark input Inputting/moving marks Inputting/moving/inserting lines Floating position setting for EBL latitude/longitude. Floating position setting for VRM latitude/longitude. Floating position setting for parallel cursor latitude/longitude. Creating latitude/longitude alarm area.
無効なバージョンです	Invalid Version	Status	<p>Program is loading a file with an incompatible version.</p> <ul style="list-style-type: none"> Internal Setting Marks/lines Own track Option languages STC curve Color
Flash ROM 異常	Flash ROM Error	Alarm	Initialization error of flash ROM file system during startup.
USB 異常	USB Error	Alarm	Initialization error of USB during startup.

4.5.2 FUSE CHECKING

Melted fuses are caused by any clear cause. When a fuse is replaced, it is necessary to check the related circuits even if there is no trouble. In checking, note that there is some dispersion in the fusing characteristics. Table 4.5-8 shows a list of fuses used in the equipment.

Table 4.5-8 Fuse List

Location	Parts No.	Current Rating	Type	Protection Circuit	Application
Display Unit	F1	10A	MF60NR 250V 10	I/F circuit	Display Unit NCD-2182
Display Unit	F2	6.3A	ST4-6.3AN1	I/F circuit	Scanner NKE-2042(4kW) NKE-2043(4kW) NKE-2062(6kW) NKE-2063(6kW) (For DC12V) for the compound modulator
Display Unit	F2	3.15A	ST4-3.15AN1	I/F circuit	Scanner NKE-2042(4kW) NKE-2043(4kW) NKE-2062/HS(6kW) NKE-2063/HS(6kW) (For DC24V) for the compound modulator
Display Unit	F2	5A	ST4-5AN1	I/F circuit	Scanner NKE-2103-4/4HS/6/6HS (10kW) for the modulator
Display Unit	F3	5A	ST4-5AN1	I/F circuit	Scanner NKE-2103-4/4HS/6/6HS (6kW) for the motor
Display Unit	F3	10A	ST6-10AN1	I/F circuit	Scanner NKE-2103-4/4HS/6/6HS (10kW) for the power supply to motor

■ Fuse Locations

Fuse locations are shown below.

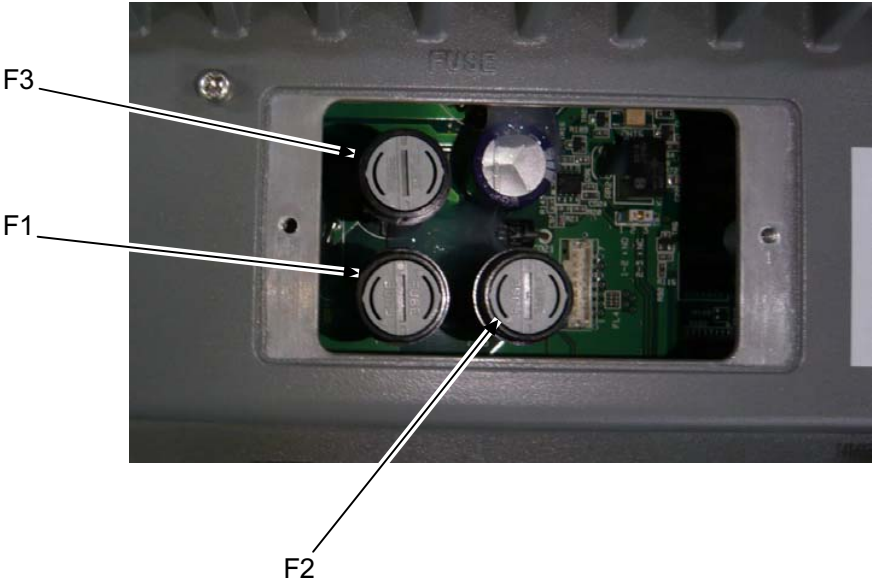

4.6 TROUBLE SHOOTING

As this radar equipment includes complicated circuits, it is necessary to request a specialist engineer for repair or instructions for remedy if any circuit is defective. There are also troubles by the following causes, which should be referred to in checking or repair work.

- Poor Contact in Terminal Board of Inter-Unit Cables
 - Poor contact in terminal board
 - The cable end is not fully connected, that it, contacted with earthed another terminal.
 - Disconnected cable wire
- Poor Contact of Connector within Unit

Reference:

This radar equipment is provided with standard included accessories shown in Table 4.6-1.

4.6.1 INCLUDED ACCESSORIES

Table 4.6-1 Included accessories

7ZXRD0012 : Scanner NKE-2042 (4kW)

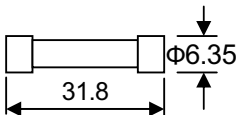
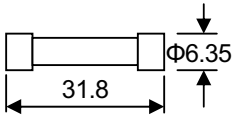
Name/Type	Parts No.	Code	Shape (mm)	Quantity	Location	Application
Fuse ST4-6.3AN1	F2	5ZFCA00051		4	Inside processing unit	(DC12V) For the modulator
Fuse ST4-3.15AN1	F2	5ZFCA00047		4	Inside processing unit	(DC24V) For the modulator

7ZXRD0012 : Scanner NKE-2043 (4kW)

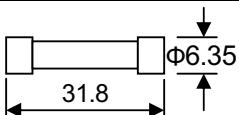
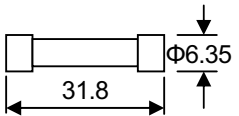
Name/Type	Parts No.	Code	Shape (mm)	Quantity	Location	Application
Fuse ST4-6.3AN1	F2	5ZFCA00051		4	Inside processing unit	(DC12V) For the compound modulator
Fuse ST4-3.15AN1	F2	5ZFCA00047		4	Inside processing unit	(DC24V) For the compound modulator

7ZXRD0013 : Scanner NKE-2062/HS (6kW)

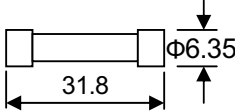
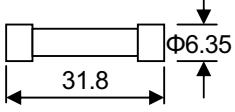
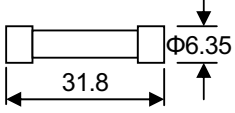
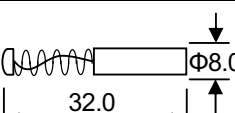
Name/Type	Parts No.	Code	Shape (mm)	Quantity	Location	Application
Fuse ST4-6.3AN1	F2	5ZFCA00051		4	Inside processing unit	NKE-2062 (DC12V) For the modulator
Fuse ST4-3.15AN1	F2	5ZFCA00047		4	Inside processing unit	NKE-2062/HS (DC24V) For the modulator
Fuse ST4-5AN1	F3	5ZFCA00050		4	Inside processing unit	NKE-2062/HS For the scanner motor
Carbon brush 54531-01	-	BRXP05247		2	Scanner	For the scanner motor

7ZXRD0013 : Scanner NKE-2063/HS (6kW)

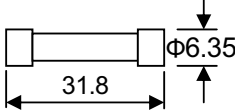
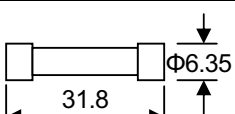
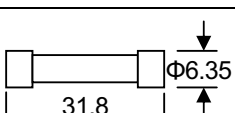
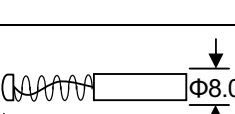
Name/Type	Parts No.	Code	Shape (mm)	Quantity	Location	Application
Fuse ST4-6.3AN1	F2	5ZFCA00051		4	Inside processing unit	NKE-2063 (DC12V) For the compound modulator
Fuse ST4-3.15AN1	F2	5ZFCA00047		4	Inside processing unit	NKE-2063/HS (DC24V) For the compound modulator
Fuse ST4-5AN1	F3	5ZFCA00050		4	Inside processing unit	NKE-2063/HS For the scanner motor
Carbon brush 54531-01	-	BRXP05247		2	Scanner	For the scanner motor

7ZXRD0026 : Scanner NKE-2103-4/4HS/6/6HS (10kW)

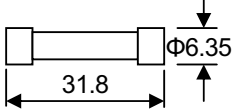
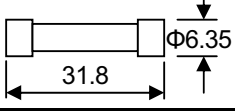
Name/Type	Parts No.	Code	Shape (mm)	Quantity	Location	Application
Fuse ST4-5AN1	F2	5ZFCA00050		4	Inside processing unit	For the modulator
Fuse ST6-10AN1	F3	5ZFCA00053		4	Inside processing unit	For the power supply to motor

Chapter 4 MAINTENANCE
4.6 TROUBLE SHOOTING

7ZXRD0028 : Display unit NDC-2182

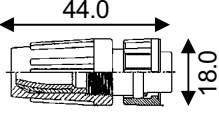
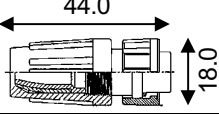
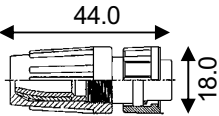
Name/Type	Parts No.	Code	Shape (mm)	Spare	Location	Application
Connector LTWBD-06BFFA-LL7001	P3	5JCDX00032		1	Inside processing unit	Mainly for GPS connection
Connector LTWBD-08BFFA-LL7001	P5	5JCDX00034		1	Inside processing unit	Mainly for connecting course equipment such as a GPS compass
Connector LTWBD-07BFFA-LL7001	P6	5JCD00033		1	Inside processing unit	For AIS connection For connecting other external devices when the AIS is not used For acquiring 2-axis logs, current data, and wind direction data

4.6.2 SPECIAL PARTS

Table 4.6-2 Special Parts

JMA-3314

Parts No.	Name	Type	Code	Manufacturer	Location
V201	Magnetron	MSF1421B	5VMAA00049	NJRC	Scanner
A101	Circulator	FCX68	6AJRD00001	Toshiba	Scanner
A102	Diode Limiter	NJS6930	5EZAA00024	NJRC	Scanner

JMA-3334

Parts No.	Name	Type	Code	Manufacturer	Location
V101	Magnetron	MSF1421B	5VMAA00092	NJRC	Scanner
A101	Circulator	FCX68R	5AJIX00027	Orient Microwave	Scanner
A102	Diode Limiter	NJS6930	5ATBT00006	NJRC	Scanner

JMA-3316/HS

Parts No.	Name	Type	Code	Manufacturer	Location
V101	Magnetron	MSF1422B	5VMAA00068	NJRC	Scanner
A101	Circulator	FCX68	6AJRD00001	Toshiba	Scanner
A102	Diode Limiter	NJS6930	5EZAA00024	NJRC	Scanner

JMA-3336/HS

Parts No.	Name	Type	Code	Manufacturer	Location
V101	Magnetron	MSF1422B	5VMAA00090	NJRC	Scanner
A101	Circulator	FCX68R	5AJIX00027	Orient Microwave	Scanner
A102	Diode Limiter	NJS6930	5ATBT00006	NJRC	Scanner

JMA-3340-4/4HS/6/6HS

Parts No.	Name	Type	Code	Manufacturer	Location
V101	Magnetron	MAF1565N	5VMAA00102	NJRC	Scanner
A101/A102	Circulator	FCX68R	5AJIX00027	Orient Microwave	Scanner
A103	Dummy	NJC4002	5ANDF00001	NJRC	Scanner
A104	Filter	NJC9952	5AWAX00002	NJRC	Scanner
A301	Diode Limiter	NJS6930	5ATBT00006	NJRC	Scanner

4.6.3 CIRCUIT BLOCK TO BE REPAIRED

Table 4.6-3 Circuit Block to be Repaired

JMA-3314

Location	Circuit Block	Type	Remarks
Scanner	Motor unit	7BDRD0023*	
Scanner	Modulation circuit	CME-322	
Scanner	Receiver	CAE-475	
Display Unit	Processing circuit	CDC-1346BR	
Display Unit	I/F circuit	CMH-2235	
Display Unit	I/F circuit	CQC-1262	
Display Unit	Operation circuit	CCK-991	
Display Unit	Operation circuit	CCK-1017	
Display Unit	Fuse	MF60NR 250V 10	F1

"*" means revision, such as A, B and so on.

JMA-3334

Location	Circuit Block	Type	Remarks
Scanner	Motor	7BDRD0052*	
Scanner	Compound Modulator Circuit	CME-385	
Scanner	Receiver Unit	NRG-239	Including CAE-548
Display Unit	Processing circuit	CDC-1346BR	
Display Unit	I/F circuit	CMH-2235	
Display Unit	I/F circuit	CQC-1262	
Display Unit	Operation circuit	CCK-991	
Display Unit	Operation circuit	CCK-1017	
Display Unit	Fuse	MF60NR 250V 10	F1

"*" means revision, such as A, B and so on.

JMA-3316/HS

Location	Circuit Block	Type	Remarks
Scanner	Motor with gear	CBP-169	DC brushless motor
Scanner	Modulator	CME-339	Excluding Magnetron
Scanner	Receiver	NRG-226	Including CAE-475-1
Display Unit	Processing circuit	CDC-1346BR	
Display Unit	I/F circuit	CMH-2235	
Display Unit	I/F circuit	CQC-1262	
Display Unit	Operation circuit	CCK-991	
Display Unit	Operation circuit	CCK-1017	
Display Unit	Fuse	MF60NR 250V 10	F1

JMA-3336/HS

Location	Circuit Block	Type	Remarks
Scanner	Motor	CBP-218	DC brushless motor
Scanner	Compound Modulator Circuit	CME-386	Excluding Magnetron
Scanner	Receiver Unit	NRG-239	Including CAE-548
Display Unit	Processing circuit	CDC-1346BR	
Display Unit	I/F circuit	CMH-2235	
Display Unit	I/F circuit	CQC-1262	
Display Unit	Operation circuit	CCK-991	
Display Unit	Operation circuit	CCK-1017	
Display Unit	Fuse	MF60NR 250V 10	F1

JMA-3340-4/4HS/6/6HS

Location	Circuit Block	Type	Remarks
Scanner	Motor with gear	7BDRD0048*	DC brushless motor
Scanner	Modulation circuit	CME-363	Excluding Magnetron
Scanner	Receiver	NRG-610	Including CAE-529-1
Scanner	Power supply circuit	CBD-1783	
Scanner	Encoder	CHT-71A	
Scanner	Motor control power circuit	CBD-1779	
Display Unit	Processing circuit	CDC-1346BR	
Display Unit	I/F circuit	CMH-2235	
Display Unit	I/F circuit	CQC-1262	
Display Unit	Operation circuit	CCK-991	
Display Unit	Operation circuit	CCK-1017	
Display Unit	Fuse	MF60NR 250V 10	F1

"*" means revision, such as A, B and so on.

Chapter 5

AFTER-SALES SERVICE

5.1 KEEPING PERIOD OF MAINTENANCE PARTS

Keeping period of maintenance parts is ten years from the production is discontinued.

5.2 WHEN YOU REQUEST FOR REPAIR

If you suppose the product may be out of order, read the description in "4.5 FAULT FINDING" and "4.6 TROUBLE SHOOTING", and check the suspected point again. If it is still out of order, you are recommended to stop operation of the equipment and consult with the dealer from whom you purchased the product, or our branch office in your country or district, the sales department in our main office in Tokyo.

- **Repair within the Warranty Period** If any failure occurs in the product during its normal operation in accordance with the instruction manual, the dealer or JRC will repair free of charge. In case that any failure is caused due to misuse, faulty operation, negligence or force major such as natural disaster and fire, the product will be repaired with charges.
- **Repair after the Warranty Period** If any defective function of the product is recoverable by repair, the repair of it will be made at your own charge upon your request.
- **Necessary Information for Repair**
 - ☆ Product name, model, manufacturing date and serial number
 - ☆ Trouble conditions (as detailed as possible. Refer to page 5-2 "■ Radar Failure Check List".)
 - ☆ Name of company/organization, address and telephone number

5.3 RECOMMENDED MAINTENANCE

The performance of the product may deteriorate due to the secular change of the parts used in it, though such deterioration depends upon the conditions of operation. So checkup and maintenance is recommendable for the product in addition to your daily care.

For maintenance, consult with the near-by dealer or our sales department.

Such maintenance will be made with charges.

For further details of after-sale service, contact the JRC Offices.

■ Radar Failure Check List

Radar Failure Check List

When placing an order for repair of the product, it is requested that you could confirm the check items and fill the results and sent the sheet to our contact.

If there is any unclear items, contact the ship on which the product is installed, and give the correct information on the product.

Ship name: _____ Phone: _____ Fax: _____

Radar general model name: JMA- _____ Serial No. : _____

(Write the full model name correctly)

(1) Check the following items in the order of the number, and circle the applicable answer between YES or NO. If the item cannot be determined as YES or NO, explain in detail in the item (17), others.

(2) If any of the items (1) to (5) is marked as NO, check the fuse of the product (refer to Section 9.1.2 and 9.2).

(3) Check the items (4) to (16) while the transmission (TX) is ON.

*Functions mentioned in the items (14), (15) and (16) may be optional, answer is not necessary.

No.	Check Item	Result	
		YES	NO
(1)	Power can be turned on. (The lamp on the Operation unit is lit)	YES	NO
(2)	A few minutes after powering-on, it will become standby status .	YES	NO
(3)	When powering-on (or TX ON), LCD monitor something is lit.	YES	NO
(4)	The antenna rotates at the transmission (TX) ON. (Check the following items while transmission is ON)	YES	NO
(5)	Current is supplied to the magnetron. (Refer to the instruction manual)	YES	NO
(6)	Turning is enabled. (Check with the range of 6 NM or more)	YES	NO
(7)	Fixed marker is displayed.	YES	NO
(8)	VRM is displayed.	YES	NO
(9)	While noise is displayed while set at SEA and RAIN minimum, GAIN maximum, IR-OFF and range 48 NM.	YES	NO
(10)	Target reflection echo is displayed.	YES	NO
(11)	Sensitivity of reflection echo is normal.	YES	NO
(12)	EBL is displayed.	YES	NO
(13)	Cursor mark moves.	YES	NO
*(14)	GYRO course can be set and normally displayed.	YES	NO
*(15)	LOG speed can be normally displayed.	YES	NO
*(16)	Target tracking function works normally.	YES	NO

(17) Others (Error message, etc.) _____

Chapter 6 DISPOSAL

6.1 DISPOSAL OF THE UNIT

When disposing of this unit, be sure to follow the local laws and regulations for the place of disposal.

6.2 DISPOSAL OF USED MAGNETRON

Magnetron is used in the Scanner (NKE-2103).

- When the magnetron is replaced with a new one, return the used magnetron to our dealer or business office.

For detail, consult with our dealer or business office.

6.3 CHINA RoHS

有毒有害物质或元素的名称及含量
(Names & Content of toxic and hazardous substances or elements)

形式名(Type): JMA-3300 Series

名称(Name): RADAR

部件名称 (Part name)	有毒有害物质或元素 (Toxic and Hazardous Substances and Elements)					
	铅 (Pb)	汞 (Hg)	镉 (Cd)	六价铬 (Cr6+)	多溴联苯 (PBB)	多溴二苯醚 (PBDE)
雷达天线单元 (Scanner Unit)	×	×	○	×	×	×
收发信单元 (Transmitter-receiver Unit)	×	×	×	×	×	×
主船内装置 (Inboard Unit) · 显示装置 (Display Unit) · 键盘装置 (Operation Unit) · 信号处理装置 (RADAR Process Unit)	×	×	×	×	×	×
外部设备 (Peripherals) · 选择 (Options) · 电线类 (Cables) · 手册 (Documents)	×	×	×	×	×	×
<p>○: 表示该有毒有害物质在该部件所有均质材料中的含量均在SJ/T11306-2006 标准规定的限量要求以下。 (Indicates that this toxic, or hazardous substance contained in all of the homogeneous materials for this part is below the requirement in SJ/T11363-2006.)</p> <p>×: 表示该有毒有害物质至少在该部件的某一均质材料中的含量超出SJ/T11363-2006 标准规定的限量要求。 (Indicates that this toxic or hazardous substance contained in at least one of the homogeneous materials used for this part is above the limit requirement in SJ/T 11363-2006.)</p>						

Chapter 7 SPECIFICATIONS

7.1 GENERAL SPECIFICATIONS

(1) Class of Emission	P0N
(2) Display	Color Raster Scan
(3) Display capability	VGA
(4) Screen	10.4-inch Color LCD
	Effective diameter of radar echo, more than 150 mm
(5) Range Scale	0.125, 0.25, 0.5, 0.75, 1.5, 3, 6, 12, 24, 48, 72 NM
	User can add 0.0625, 1, 2, 4, 8, 16, 32 or 64 NM.
	* Off Center is not available at 64, 72NM.
(6) Range Resolution	Less than 30m
(7) Minimum Detective Range	Less than 40m
(8) Range Accuracy	Less than 1% of the maximum distance of the range scale in use or less than 15m whichever is larger
(9) Bearing Accuracy	Less than 1°
(10) Bearing Indication	Head-up, North-up, Course-up
(11) Ambient Condition	
Standards	IEC60945 Ed.4.0
Temperature	
Scanner	Operation: -25 to +55°C / Storage: -25 to +70°C
Other Unit except Scanner	Operation: -15 to +55°C
Relative Humidity	
Entire Unit	+40°C, 93%
Vibration	
Entire Unit	2 to 13.2 Hz, amplitude±1mm 13.2 to 100 Hz0.7 G
Velocity of the wind	51.5m/s (100kn)
Waterproof/dustproof	Scanner IP26 Display Unit IP55 (front panel)
(12) Power Supply Input	DC+24V (All models, cable length of 30m or less) DC+12V (4 kW/6 kW models, cable length of 20m or less)

Chapter 7 SPECIFICATIONS
7.1 GENERAL SPECIFICATIONS

(13) Power Consumption	In calm wind: Approx. 60W (NKE-2042) Approx. 60W (NKE-2043) Approx. 85W (NKE-2062) Approx. 85W (NKE-2063) Approx. 85W (NKE-2062HS) Approx. 85W (NKE-2063HS) Approx. 100W (NKE-2103-4) Approx. 100W (NKE-2103-4HS) Approx. 100W (NKE-2103-6) Approx. 100W (NKE-2103-6HS) Maximum (Velocity of the wind: 100 kn): Approx. 60W (NKE-2042) Approx. 60W (NKE-2043) Approx. 230W (NKE-2062) Approx. 180W (NKE-2063) Approx. 230W (NKE-2062HS) Approx. 230W (NKE-2063HS) Approx. 360W (NKE-2103-4) Approx. 360W (NKE-2103-4HS) Approx. 360W (NKE-2103-6) Approx. 360W (NKE-2103-6HS)
(14) Range of power supply voltage fluctuation	+10.8 to 41.6 VDC (Display Unit) (4kW/6kW) +21.6 to 31.2 VDC (Display Unit) (6kWS/10kW/10kWS)
(15) Pre-heating Time	Approx. Within 1min30sec
(16) Scanner	Refer to Scanner Specifications
(17) Display unit	Refer to Display Unit Specifications
(18) Inter-Unit Cables	Using common scanner connecting cable CFQ-6912-** Maximum cable length: 30 m

7.2 SCANNER

7.2.1 NKE-2042

- | | | |
|--|---|---------------------|
| (1) Dimensions | Height 275mm × Diameter of radome 620mm | |
| (2) Mass | Approx. 10.5kg | |
| (3) Polarization | Horizontal Polarization | |
| (4) Directional Characteristic | | |
| Horizontal Beam Width (-3dB): | 2° | |
| Vertical Beam Width (-3dB): | 25° | |
| Sidelobe Level: | -21dB or less (less than ±10° from the main lobe) | |
| (5) Rotation | Approx. 27rpm (NKE-2042) | |
| (6) Peak Power | 4 kW | |
| (7) Transmitting Frequency | 9410 ±30MHz | |
| (8) Transmitting Tube | Magnetron [MSF1421B] | |
| (9) Pulse width/Repetition Frequency (Bandwidth) | | |
| SP: 0.08μs/2250 Hz | | |
| MP1: 0.25μs/1700 Hz, MP2: 0.5μs/1200 Hz | | |
| LP1: 1.0μs/650 Hz | | |
| 0.125NM | 0.08μs/2250Hz (SP) | |
| 0.25NM | 0.08μs/2250Hz (SP) | |
| 0.5NM | 0.08μs/2250Hz (SP) | 0.25μs/1700Hz (MP1) |
| 0.75NM | 0.08μs/2250Hz (SP) | 0.25μs/1700Hz (MP1) |
| 1.5NM | 0.08μs/2250Hz (SP) | 0.25μs/1700Hz (MP1) |
| 3NM | 0.25μs/1700Hz (MP1) | 0.5μs/1200Hz (MP2) |
| 6NM | 0.5μs/1200Hz (MP2) | 1.0μs/650Hz (LP1) |
| 12NM | 1.0μs/650Hz (LP1) | |
| 24NM | 1.0μs/650Hz (LP1) | |
| 48NM | 1.0μs/650Hz (LP1) | |
| (10) Duplexer | Circulator + Diode Limiter | |
| (11) Front End Module | MIC | |
| (12) Intermediate Frequency Amplifier | | |
| Intermediate Frequency: | 60MHz | |
| Band Width: | 20MHz (0.08μs) | |
| | 6MHz (0.25μs, 0.5μs) | |
| | 3MHz (1.0μs) | |
| Gain: | More than 90dB | |
| Amplifying Characteristics: | Logarithmic Amplifier | |
| (13) Overall Noise Figure | 6dB (Average) | |

7.2.2 NKE-2043

(1) Dimensions	Height 275mm × Diameter of radome 620mm		
(2) Mass	Approx. 10kg		
(3) Polarization	Horizontal Polarization		
(4) Directional Characteristic	Horizontal Beam Width (-3dB):		
	4°		
	Vertical Beam Width (-3dB):		
	25°		
	Sidelobe Level: -21dB or less (less than ±10° from the main lobe)		
(5) Rotation	Approx. 27rpm (NKE-2043)		
	(16/20/24/27/30/36/42/48rpm can be set)		
(6) Peak Power	4 kW		
(7) Transmitting Frequency	9410 ±30MHz		
(8) Transmitting Tube	Magnetron [MSF1421B]		
(9) Pulse width/Repetition Frequency (Bandwidth)	SP1: 0.08μs/4000Hz, SP2: 0.08μs/2250Hz, SP3: 0.13μs/1700Hz		
	MP1: 0.25μs/1700Hz, MP2: 0.5μs/1200Hz		
	LP1: 0.8μs/750Hz, LP2: 1.0μs/650Hz		
	0.125NM	0.08μs/4000Hz (SP1)	
	0.25NM	0.08μs/4000Hz (SP1)	
	0.5NM	0.08μs/4000Hz (SP1)	0.25μs/1700Hz (MP1)
	0.75NM	0.08μs/2250Hz (SP2)	0.25μs/1700Hz (MP1)
	1.5NM	0.08μs/2250Hz (SP2)	0.25μs/1700Hz (MP1) 0.5μs/1200Hz (MP2)
	3NM	0.13μs/1700Hz (SP3)	0.25μs/1700Hz (MP1) 0.5μs/1200Hz (MP2)
	6NM	0.5μs/1200Hz (MP2)	0.8μs/750Hz (LP1) 1.0μs/650Hz (LP2)
	12NM	0.5μs/1200Hz (MP2)	0.8μs/750Hz (LP1) 1.0μs/650Hz (LP2)
	24NM	1.0μs/650Hz (LP2)	
	48NM	1.0μs/650Hz (LP2)	
	72NM	1.0μs/650Hz (LP2)	
(10) Duplexer	Circulator + Diode Limiter		
(11) Front End Module	MIC		
(12) Intermediate Frequency Amplifier	Intermediate Frequency: 60MHz		
	Band Width: 20MHz (0.08μs, 0.13μs)		
	6MHz (0.25μs)		
	3MHz (0.5μs, 0.8μs, 1.0μs)		
	Gain: More than 90dB		
	Amplifying Characteristics: Logarithmic Amplifier		
(13) Overall Noise Figure	6dB (Average)		

7.2.3 NKE-2062/HS

- | | | |
|--|--|--|
| (1) Dimensions | Height 432mm × Swing Circle 1220mm | |
| (2) Mass | Approx. 24kg | |
| (3) Polarization | Horizontal Polarization | |
| (4) Directional Characteristic | Horizontal Beam Width (-3dB):
2° | |
| | Vertical Beam Width (-3dB):
30° | |
| | Sidelobe Level: -23dB or less (less than ±10° from the main lobe)
-26dB or less (±10° or more from the main lobe) | |
| (5) Rotation | Approx. 27rpm (NKE-2062)
Approx. 48rpm (NKE-2062HS) | |
| (6) Peak Power | 6 kW | |
| (7) Transmitting Frequency | 9410 ±30MHz | |
| (8) Transmitting Tube | Magnetron [MSF1422B] | |
| (9) Pulse width/Repetition Frequency (Bandwidth) | SP: 0.08μs/2250 Hz
MP1: 0.25μs/1700 Hz, MP2: 0.5μs/1200 Hz
LP1: 1.0μs/650 Hz | |
| | 0.125NM | 0.08μs/2250Hz (SP) |
| | 0.25NM | 0.08μs/2250Hz (SP) |
| | 0.5NM | 0.08μs/2250Hz (SP) 0.25μs/1700Hz (MP1) |
| | 0.75NM | 0.08μs/2250Hz (SP) 0.25μs/1700Hz (MP1) |
| | 1.5NM | 0.08μs/2250Hz (SP) 0.25μs/1700Hz (MP1) |
| | 3NM | 0.25μs/1700Hz (MP1) 0.5μs/1200Hz (MP2) |
| | 6NM | 0.5μs/1200Hz (MP2) 1.0μs/650Hz (LP1) |
| | 12NM | 1.0μs/650Hz (LP1) |
| | 24NM | 1.0μs/650Hz (LP1) |
| | 48NM | 1.0μs/650Hz (LP1) |
| | 72NM | 1.0μs/650Hz (LP1) |
| (10) Duplexer | Circulator + Diode Limiter | |
| (11) Front End Module | MIC | |
| (12) Intermediate Frequency Amplifier | Intermediate Frequency: 60MHz | |
| | Band Width: 20MHz (0.08μs)
6MHz (0.25μs, 0.5μs)
3MHz (1.0μs) | |
| | Gain: More than 90dB | |
| | Amplifying Characteristics: Logarithmic Amplifier | |

Chapter 7 SPECIFICATIONS
7.2 SCANNER

- | | |
|---------------------------|---------------|
| (13) Overall Noise Figure | 6dB (Average) |
| (14) Tune | AUTO/MANUAL |

7.2.4 NKE-2063/HS

- | | |
|--|--|
| (1) Dimensions | Height 419.5mm × Swing Circle 1220mm |
| (2) Mass | Approx. 21kg |
| (3) Polarization | Horizontal Polarization |
| (4) Directional Characteristic | |
| Horizontal Beam Width (-3dB): | 2° |
| Vertical Beam Width (-3dB): | 30° |
| Sidelobe Level: | -23dB or less (less than ±10° from the main lobe)
-26dB or less (±10° or more from the main lobe) |
| (5) Rotation | Approx. 27rpm (NKE-2063)
(16/17.4/19/20.6/22.2/23.8/25.4/27rpm can be set)
Approx. 48rpm
(27/36/48rpm can be set) |
| (6) Peak Power | 6 kW |
| (7) Transmitting Frequency | 9410 ±30MHz |
| (8) Transmitting Tube | Magnetron [MSF1422B] |
| (9) Pulse width/Repetition Frequency (Bandwidth) | |
| SP1: 0.08μs/4000Hz, SP2: 0.08μs/2250Hz, SP3: 0.13μs/1700Hz | |
| MP1: 0.25μs/1700 Hz, MP2: 0.5μs/1200 Hz | |
| LP1: 0.8μs/750Hz, LP2: 1.0μs/650Hz | |
| 0.125NM | 0.08μs/4000Hz (SP1) |
| 0.25NM | 0.08μs/4000Hz (SP1) |
| 0.5NM | 0.08μs/4000Hz (SP1) 0.25μs/1700Hz (MP1) |
| 0.75NM | 0.08μs/2250Hz (SP2) 0.25μs/1700Hz (MP1) |
| 1.5NM | 0.08μs/2250Hz (SP2) 0.25μs/1700Hz (MP1) 0.5μs/1200Hz (MP2) |
| 3NM | 0.13μs/1700Hz (SP3) 0.25μs/1700Hz (MP1) 0.5μs/1200Hz (MP2) |
| 6NM | 0.5μs/1200Hz (MP2) 0.8μs/750Hz (LP1) 1.0μs/650Hz (LP2) |
| 12NM | 0.5μs/1200Hz (MP2) 0.8μs/750Hz (LP1) 1.0μs/650Hz (LP2) |
| 24NM | 1.0μs/650Hz (LP2) |
| 48NM | 1.0μs/650Hz (LP2) |
| 72NM | 1.0μs/650Hz (LP2) |
| (10) Duplexer | Circulator + Diode Limiter |
| (11) Front End Module | MIC |

- (12) Intermediate Frequency Amplifier
 - Intermediate Frequency: 60MHz
 - Band Width: 20MHz (0.08 μ s, 0.13 μ s)
6MHz (0.25 μ s)
3MHz (0.5 μ s, 0.8 μ s, 1.0 μ s)
 - Gain: More than 90dB
 - Amplifying Characteristics: Logarithmic Amplifier
- (13) Overall Noise Figure 6dB (Average)
- (14) Tune AUTO/MANUAL

7.2.5 NKE-2103-4/6/4HS/6HS

(1) Dimensions	Height: approx. 458 mm Swing Circle: approx. 1,285mm (4ft) Height: approx. 458 mm Swing Circle: approx. 1910 mm (6ft)
(2) Mass	Approx. 38 kg (4ft) Approx. 40 kg (6ft)
(3) Polarization	Horizontal Polarization
(4) Directional Characteristic	
Horizontal Beam Width (-3dB)	1.8° (4ft) 1.2° (6ft)
Vertical Beam Width (-3dB)	20° (4ft/6ft)
Sidelobe Level	-26 dB or less (less than ±10° from the main lobe) (4ft/6ft) -30 dB or less (±10° or more from the main lobe) (4ft/6ft)
(5) Rotation	27rpm (NKE-2103-4/6) 48rpm (NKE-2103-4HS/6HS)
(6) Transmitting Frequency	9410 ±30 MHz
(7) Peak Power	10 kW ±50%
(8) Transmitting Tube	Magnetron [MAF1565N]
(9) Transmitting Pulse Width/Repetition Frequency (Bandwidth)	
SP: 0.08μs/2250 Hz	
MP1: 0.25μs/1700 Hz, MP2: 0.5μs/1200 Hz	
LP1: 0.8μs/750 Hz, LP2: 1.0μs/650 Hz	
0.125NM	0.08μs/2250Hz (SP)
0.25NM	0.08μs/2250Hz (SP)
0.5NM	0.08μs/2250Hz (SP) 0.25μs/1700Hz (MP1)
0.75NM	0.08μs/2250Hz (SP) 0.25μs/1700Hz (MP1)
1.5NM	0.08μs/2250Hz (SP) 0.25μs/1700Hz (MP1) 0.5μs/1200Hz (MP2)
3NM	0.25μs/1700Hz (MP1) 0.5μs/1200Hz (MP2) 0.8μs/750Hz (LP1)
6NM	0.5μs/1200Hz (MP2) 0.8μs/750Hz (LP1) 1.0μs/650Hz (LP2)
12NM	0.5μs/1200Hz (MP2) 0.8μs/750Hz (LP1) 1.0μs/650Hz (LP2)
24NM	1.0μs/650Hz (LP2)
48NM	1.0μs/650Hz (LP2)
72NM	1.0μs/650Hz (LP2)
(10) Duplexer	Circulator + Diode Limiter

Chapter 7 SPECIFICATIONS
7.2 SCANNER

- (11) Front End Module MIC
- (12) Intermediate Frequency Amplifier
 - Intermediate Frequency: 60MHz
 - Band Width: 20MHz (0.08 μ s)
 - 6MHz (0.25 μ s, 0.5 μ s)
 - 3MHz (0.8 μ s, 1.0 μ s)
 - Gain: More than 90dB
 - Amplifying Characteristics: Logarithmic Amplifier
- (13) Overall Noise Figure 7.5dB (Average)
- (14) Tune Method AUTO/MANUAL

Chapter 7 SPECIFICATIONS
7.3 DISPLAY UNIT

	When the motion is switched (between RM (T) and TM), true motion trails is transition.
	* When switching to true/relative trails, the radar trails are cleared.
(14) Variety of Pulse width	SP/MP1/MP2/LP1 (NKE-2042) SP/MP1/MP2/LP1 (NKE-2062) SP/MP1/MP2/LP1/LP2 (NKE-2103)
(15) Target enhance	3 stages
(16) Plotting	Line/200 marks/3 colors for own ship's tracks, line types selectable
(17) Display color	
Radar echo	16 stages, 5 colors (Yellow, Green, Orange, Purple, Red, Colored)
Radar trails	16 stages 3 colors for time trails (Green, White, Light Blue) 3 colors for continuous trails (Green, White, Light Blue)
Background within PPI	3 colors (Black, Blue, Navy Blue)
Characters	5 colors (White, Orange, Green, Black, Red)
Cursor	4 colors (Cyan, Orange, Green, White)
AIS/vector	3 colors (Cyan, Green, White)
EBL/VRM	4 colors (Light Blue, Orange, Green, White)
(18) Simulator	Built-in simulator
(19) Full screen	Full screen (displayed without PPI mask)
(20) Multiple languages	Japanese, English, French, German, Spanish, Italian, Portuguese, Norwegian
(21) LL / TD conversion	Built-in
(22) Navigation information during STBY	Built-in
(23) Land mile display	Range, scale, VRM
(24) Barge display	Displays the own ship and a barge.
(25) AIS information display	(MMSI, ship name) List display, Retrieved Vessel, WPT setting

7.3.2 OPERATION PANEL

(1) Structure	Integrated on the display unit
(2) Controls	GAIN SEA RAIN MULTI Cursor keys
(3) Keys	
STBY	Stops transmission (Turns off the equipment if simultaneously pressed with "TX/PRF")
TX/PRF	Starts transmission (Turns off the equipment if simultaneously pressed with "STBY") Changes PRF during transmission. Clears SHM when held down.
RANGE+	Increases the distance range.
RANGE-	Decreases the distance range.
FUNC	Switches the function.
BRILL	Adjusts LCD brightness
ENT	Enter key (Selects menu items, etc)
CLEAR	Cancels operations
MENU	Opens/closes the menu screen
Soft key 1	Soft key 1
Soft key 2	Soft key 2
Soft key 3	Soft key 3
Soft key 4	Soft key 4

7.3.3 AIS FUNCTION

(1) Screen	
Number of targets	Up to 50 targets (stores up to 500 ship static data)
Target information	Displays MMSI, call sign, ship name, COG, SOG, CPA, TCPA, direction, distance, latitude, longitude, status, etc.
Filters	Distance only
Active targets	Not available
Dangerous ship targets	No CPA/TCPA decision
(2) Operation	Built-in

7.3.4 TT FUNCTION

(1) Acquisition	MANUAL/AUTO (by automatic acquisition/activation zone)
(2) Tracking	10 targets (Automatic tracking)
(3) Display	
Tracking data	1 ship (AIS or TT)
Maximum tracking range	20 NM This varies depending on the range.
Target information	Displays items selected from true bearing, distance, true course, true speed, CPA, TCPA.
Display of Vectors	True/Relative
Dangerous ship targets	Decision by CPA/TCPA
(4) Operation	Built-in

7.4 INPUT/OUTPUT SIGNAL

7.4.1 INPUT ENABLE SIGNAL

(1) Navigation equipment	IEC61162-1/2 Longitude/Latitude: GGA>RMC>GNS>GLL COG/SOG: RMC>VTG Log speed: VBW>VHW, NSK data Bearing: THS>HDT>HDG>HDM Depth: DPT>DBT Water temperature: MTW Rate of Turn: ROT Rudder: RSA AIS: VDM, VDO, ALR Direction of wind, velocity of wind: MWV>VWT, VWR
(2) Bearing signal	GYRO-SYNC: 360X, 180X, 90X, 36X (Require optional NSK unit NCT-4106A) GYRO-STEP: 360X, 180X, 90X, 36X (Require optional NSK unit NCT-4106A) JRC-NSK format (JLR-10/20/30) IEC61162 4800bps/38400bps: THS>HDT>HDG>HDM
(3) Speed signal	LOG-SYNC: 360X, 180X, 90X, 30X (Require optional NSK unit NCT-4106A) LOG-PULSE: 800, 400, 200, 100 (Require optional NSK unit NCT-4106A) IEC61162 4800bps: VBW, VHW

7.4.2 OUTPUT ENABLE SIGNAL

(1) Navigation information	IEC61162-1/2 Radar data: RSD Own ship's data: OSD TT data: TTM, TLL, TTD latitude/longitude data: GGA, RMC, GNS, GLL COG/SOG: RMC, VTG Bearing signal: THS, HDT
(2) External buzzer	Factory presetting: normal open contacts

7.5 STANDARD CONFIGURATION

Scanner:	1 unit
Display Unit:	1 unit
Standard included accessories:	1 set
Instruction manual:	1 book
Installation manual:	1 book
Quick instruction:	1 book

APPENDIX

Fig. A1 NKE-2042 SCANNER INTERCONNECTION DIAGRAM

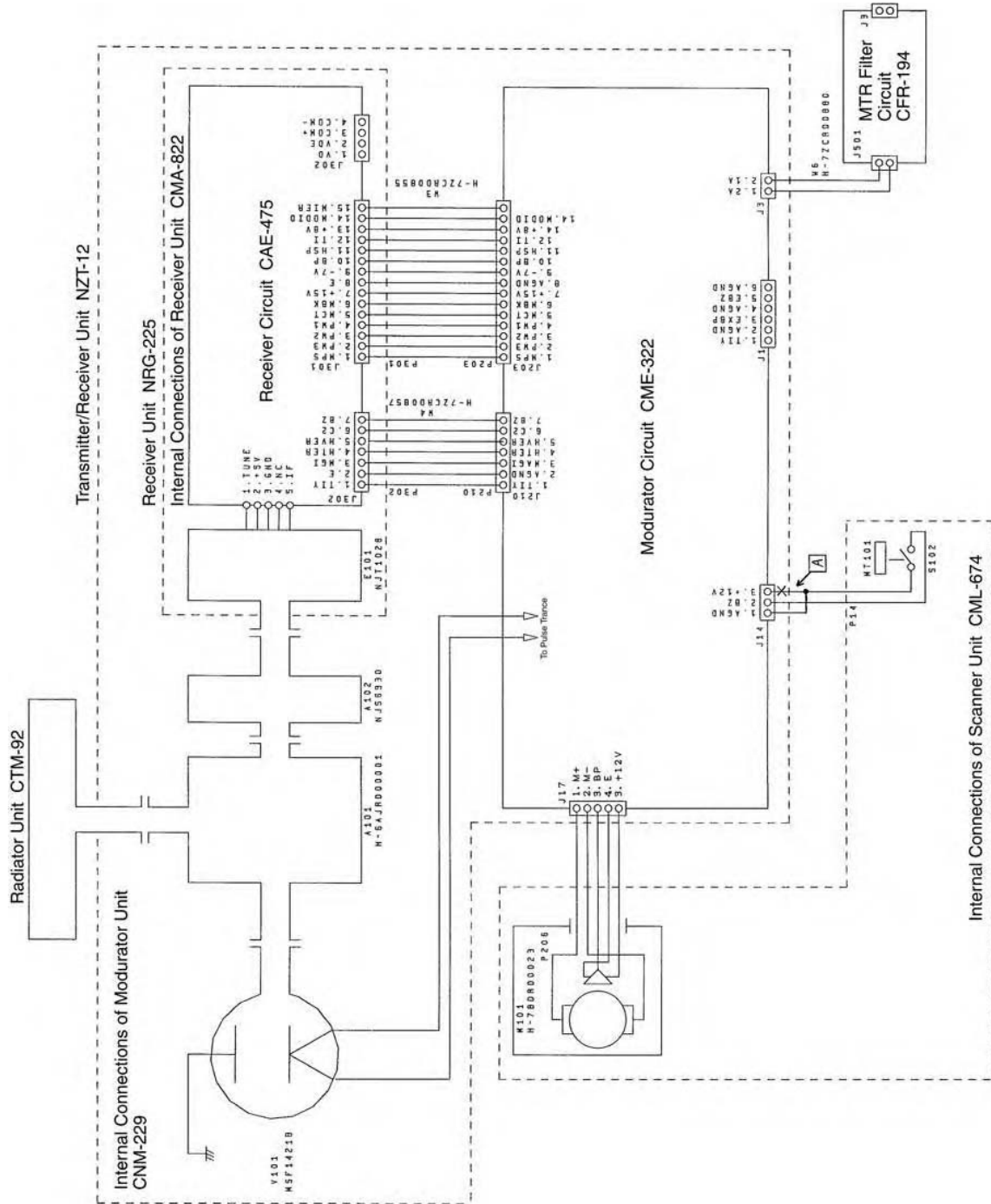

APPENDIX

INSTRUCTION MANUAL

Fig. A2 NKE-2043 SCANNER INTERCONNECTION DIAGRAM

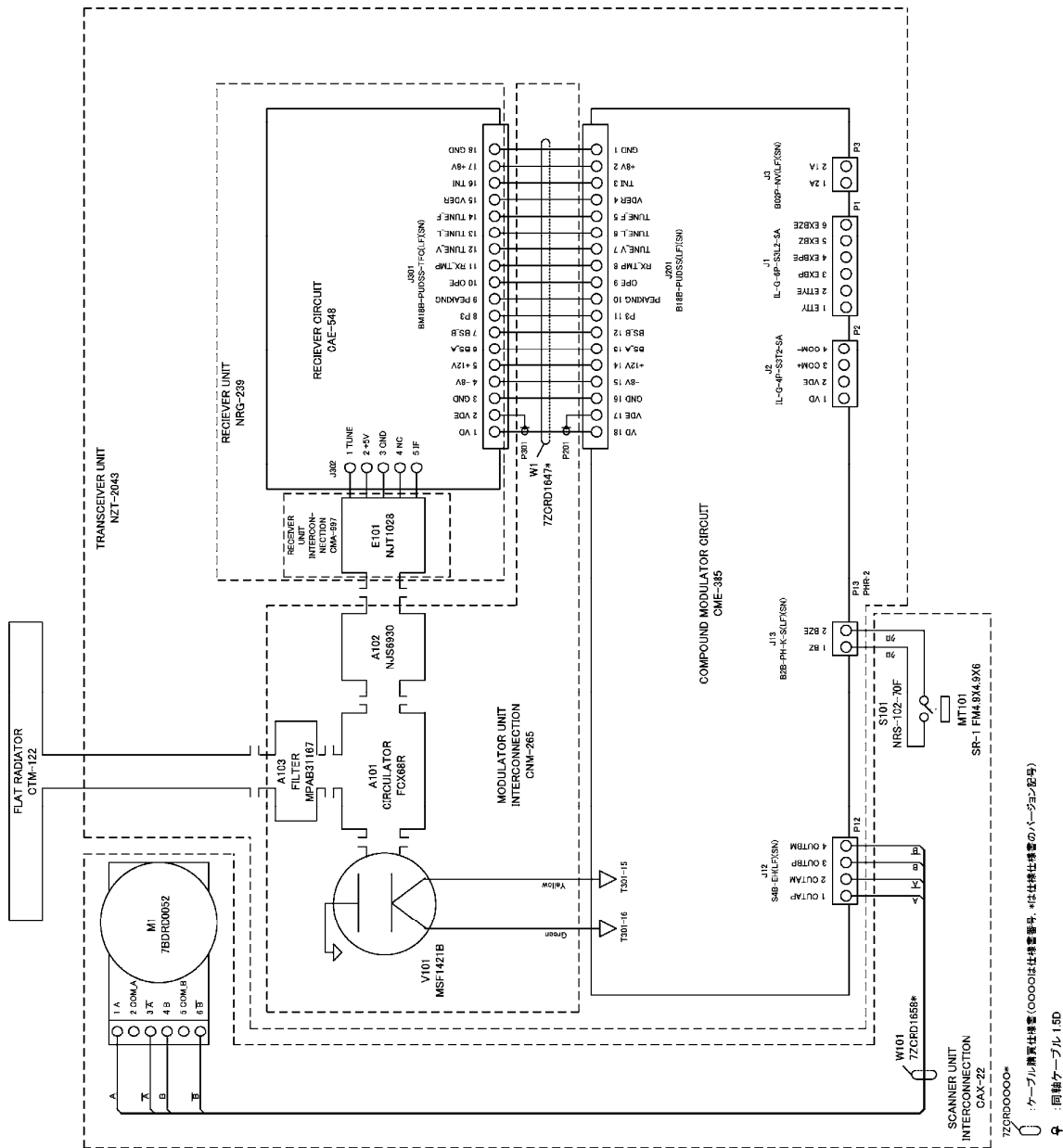
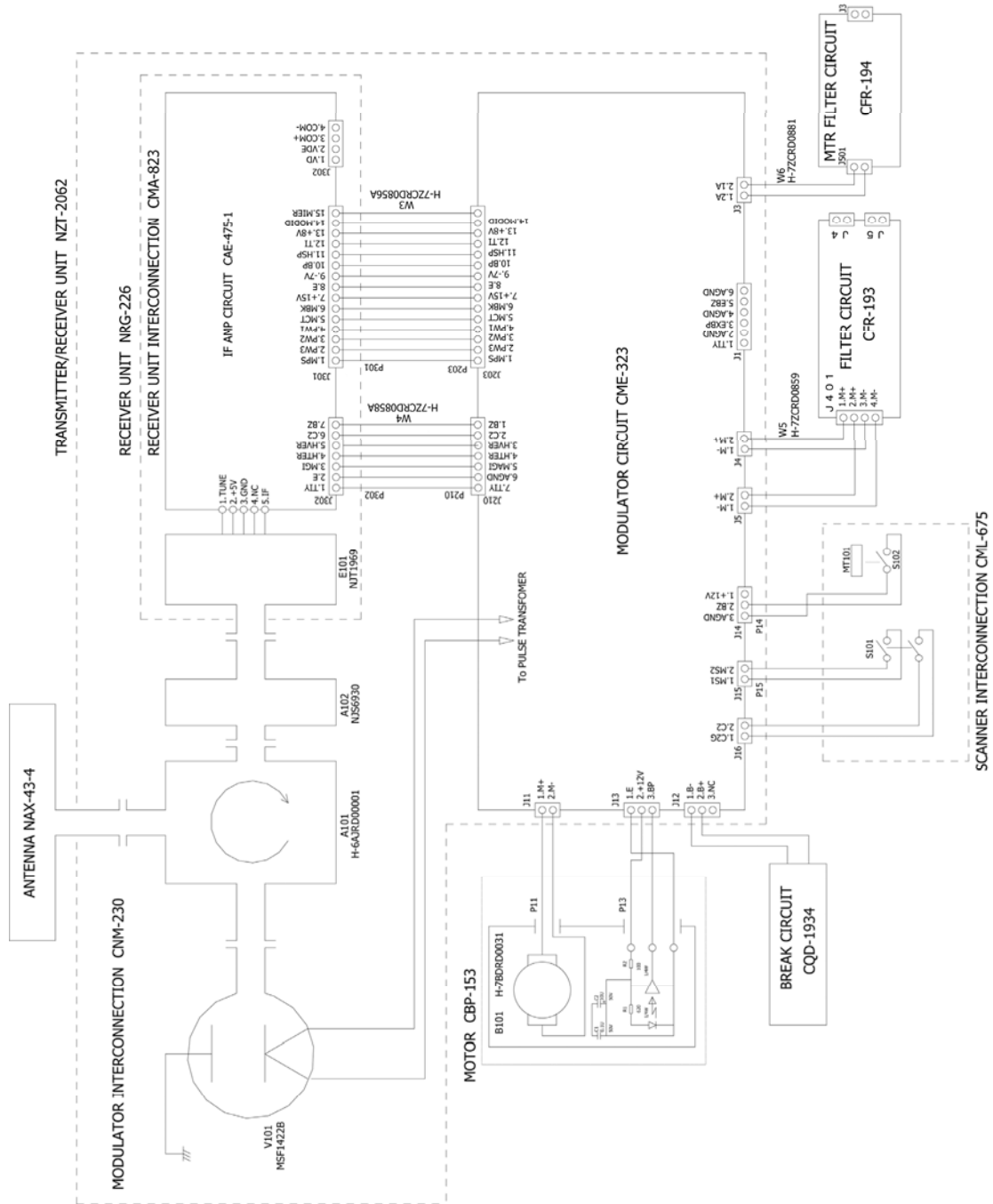

Fig. A3 NKE-2062 SCANNER INTERCONNECTION DIAGRAM



APPENDIX

INSTRUCTION MANUAL

Fig. A4 NKE-2062HS SCANNER INTERCONNECTION DIAGRAM

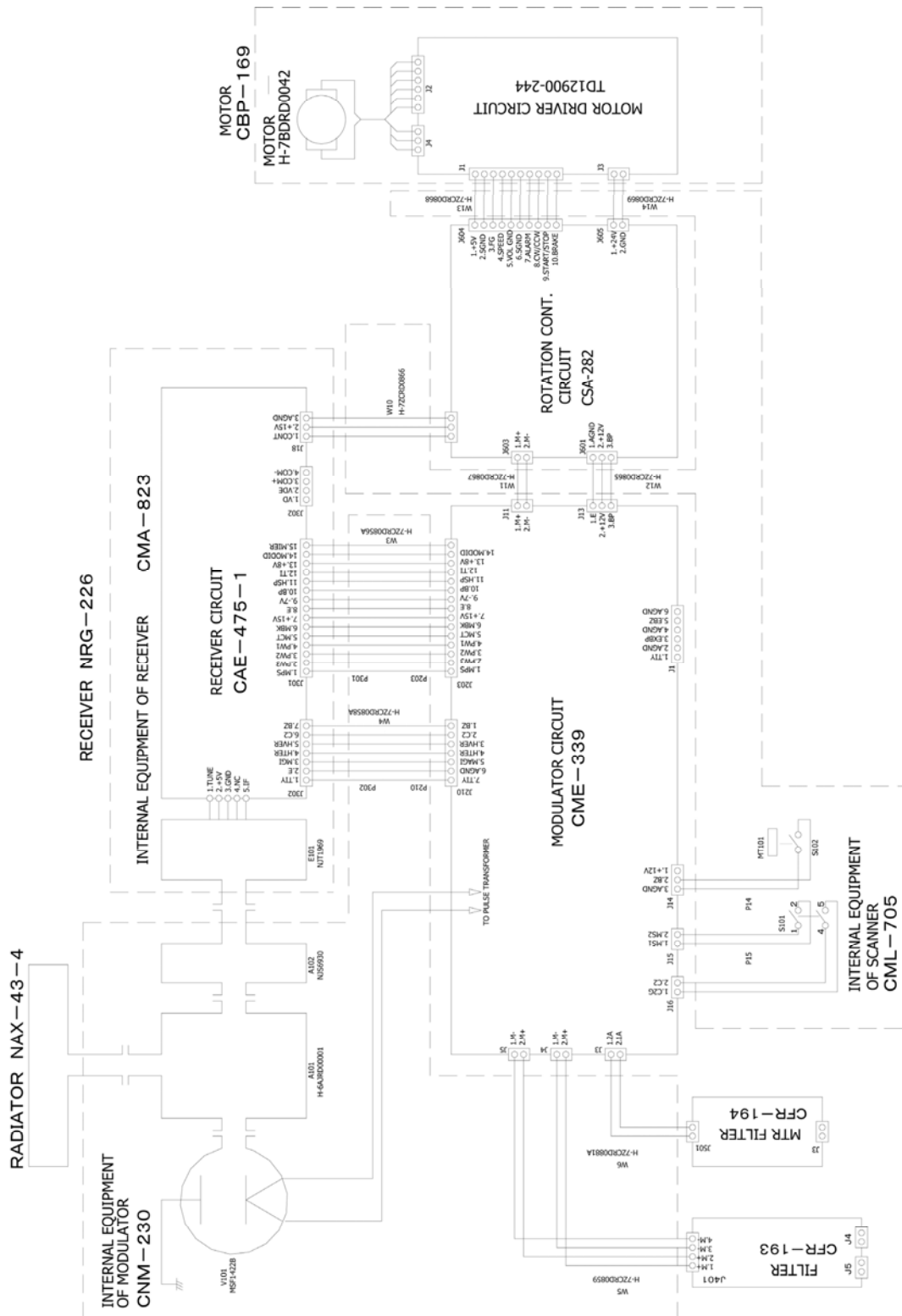
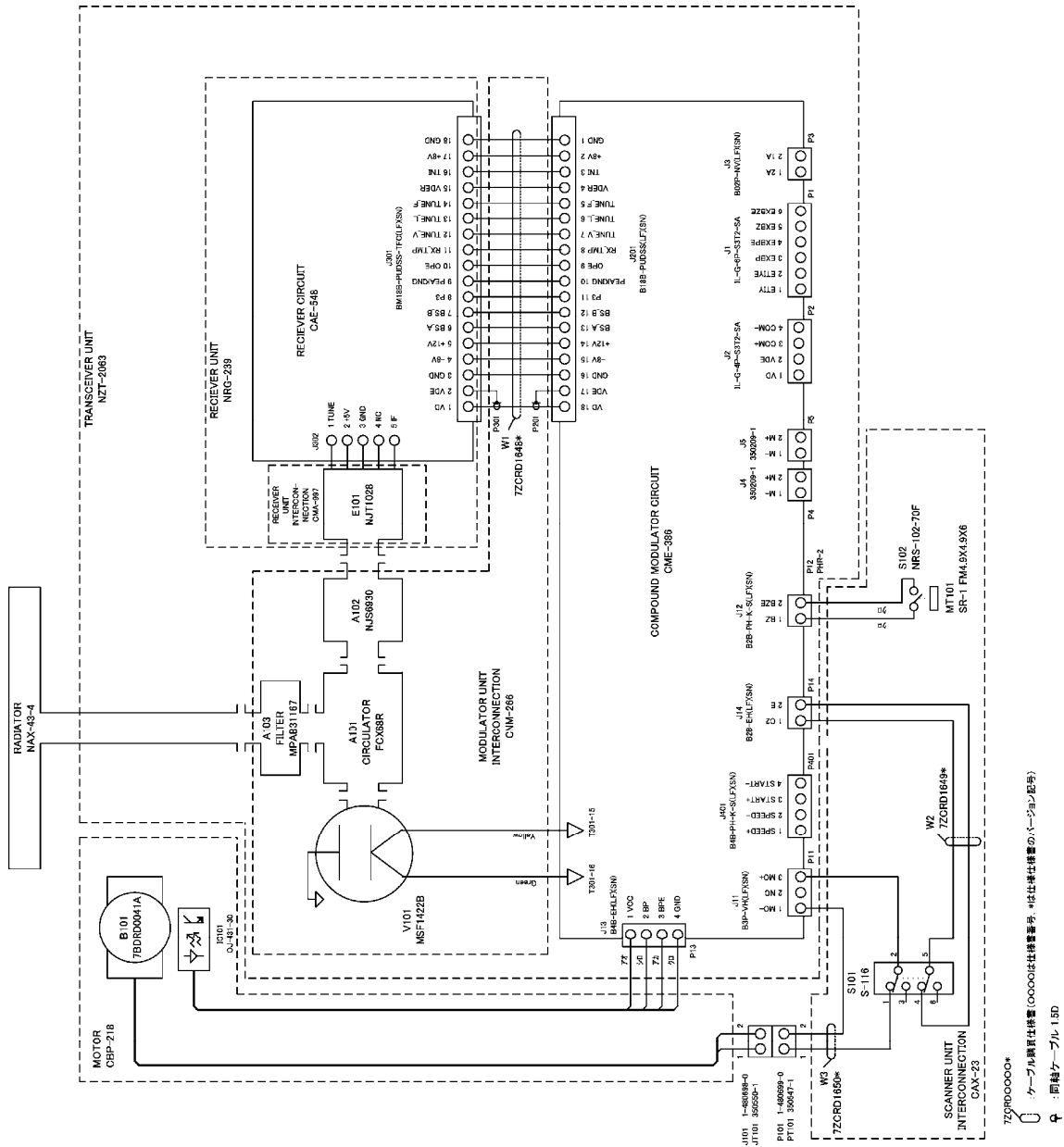

Fig. A5 NKE-2063 SCANNER INTERCONNECTION DIAGRAM



TZCRD00000*
 ○ ケーブル固有仕様書(00000は仕様番号、*は仕様標準のバージョン記号)
 ♀ : 回転ケーブル 1.5D

APPENDIX

INSTRUCTION MANUAL

Fig. A6 NKE-2063HS SCANNER INTERCONNECTION DIAGRAM

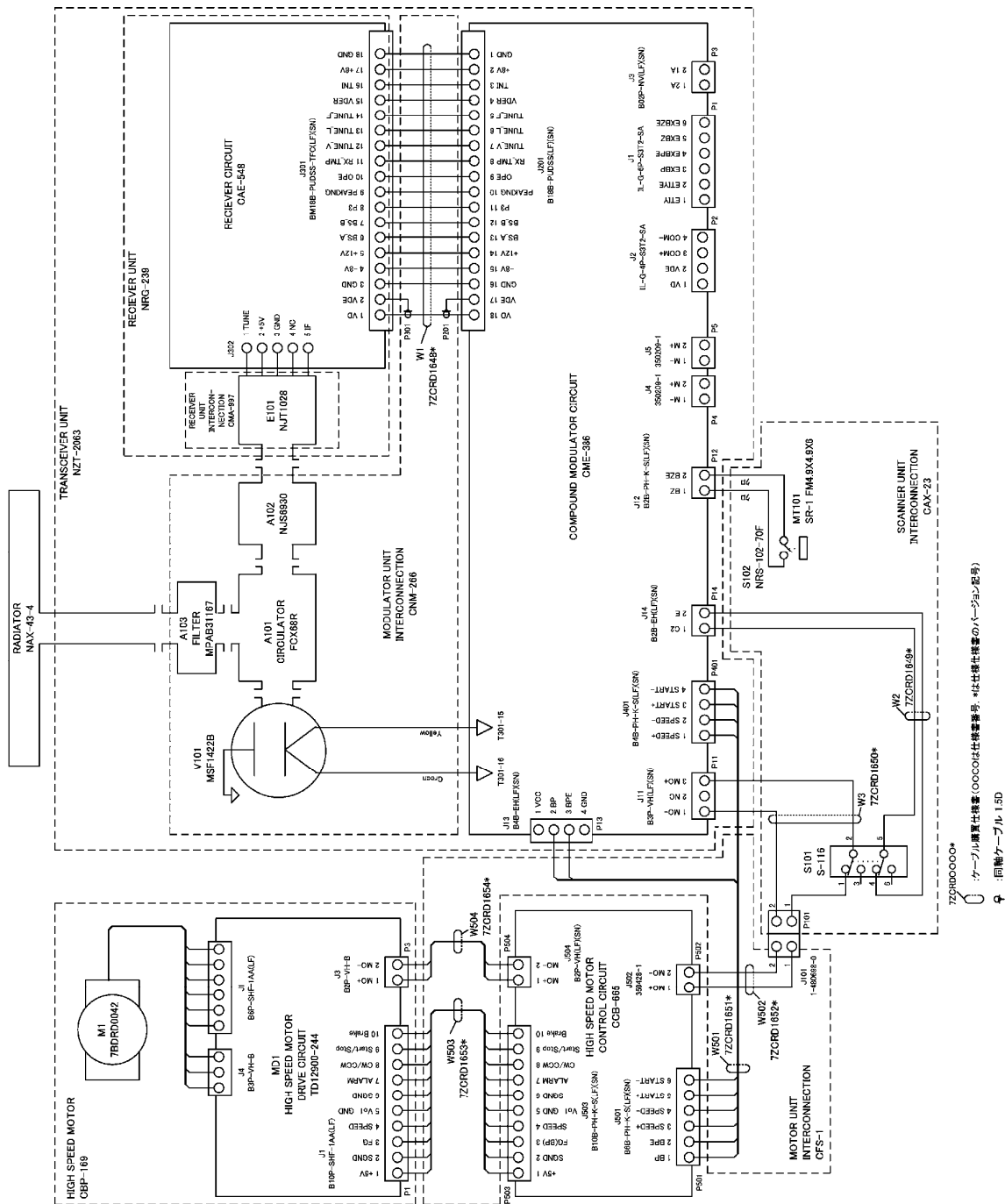

○: ケーブル購買仕様書 (○○○は仕様番号, *は仕様書のパージョン記号)
 ♀: 同軸ケーブル 1.5D

Fig. A7 NKE-2103-4/4HS/6/6HS SCANNER INTERCONNECTION DIAGRAM

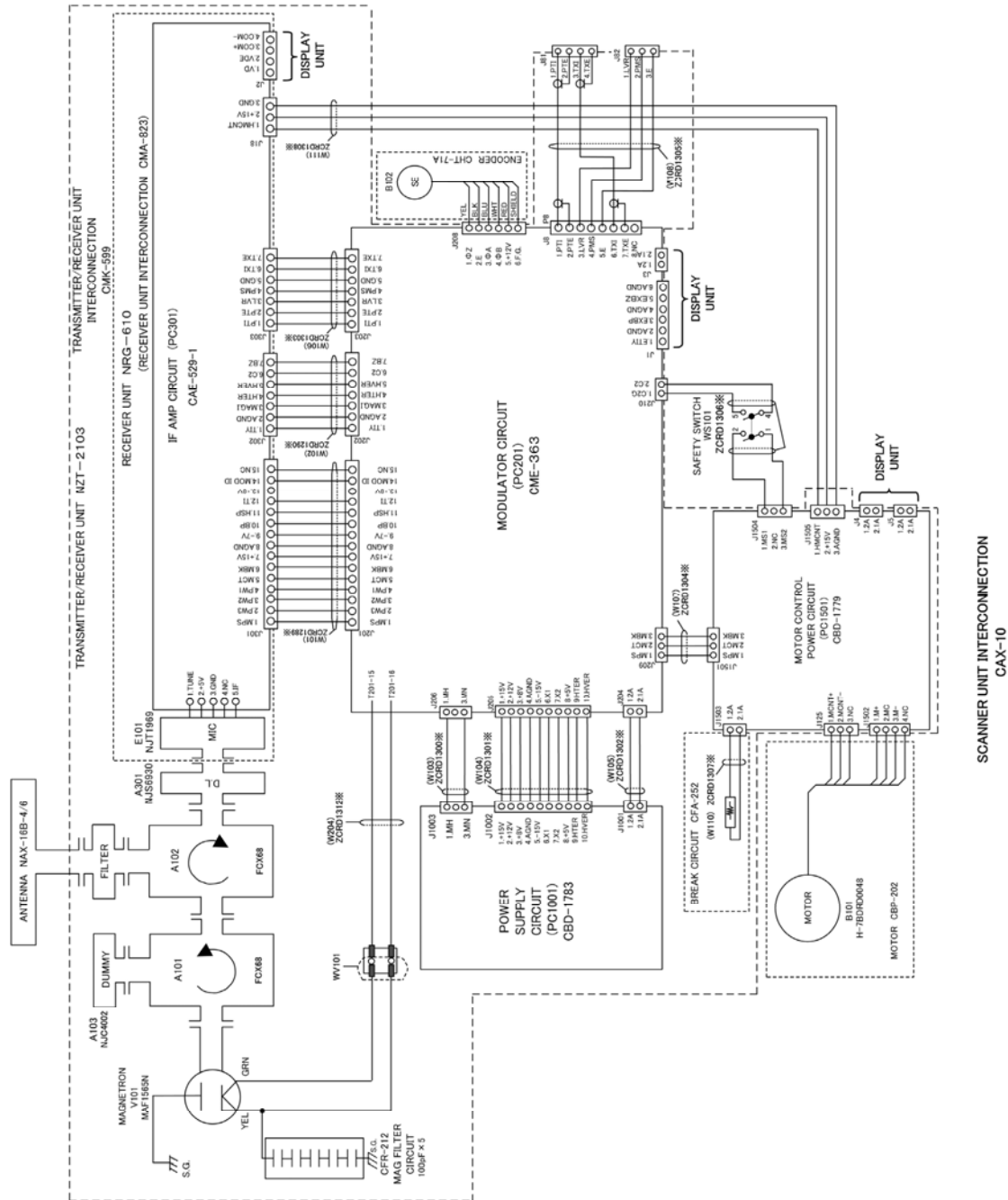

SCANNER UNIT INTERCONNECTION
CAX-10

APPENDIX

INSTRUCTION MANUAL

Fig. A8 NCD-2182 DISPLAY UNIT INTERCONNECTION DIAGRAM

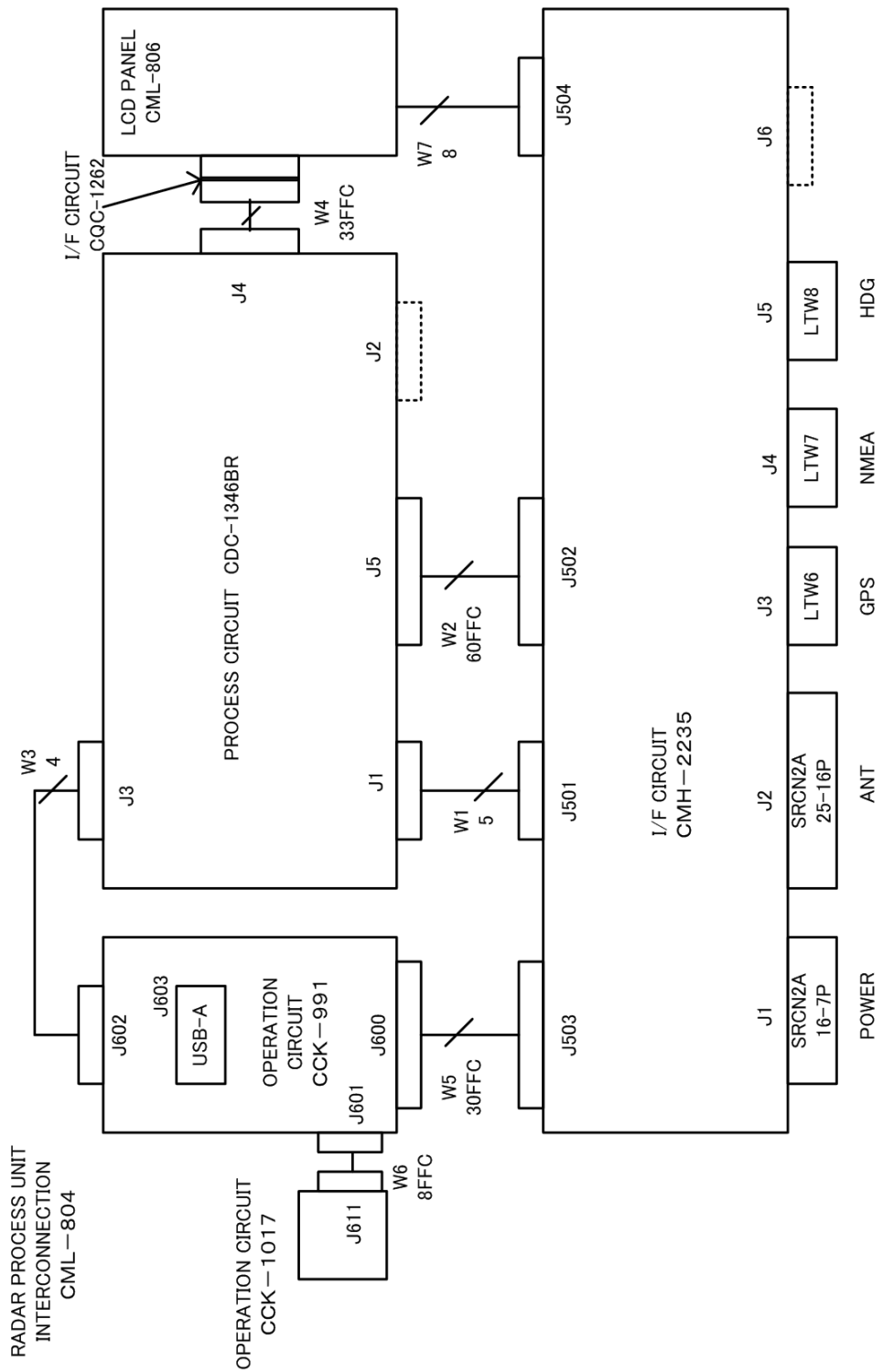

Fig. A9 PRIMARY POWER SUPPLY DIAGRAM, TYPE JMA-3300

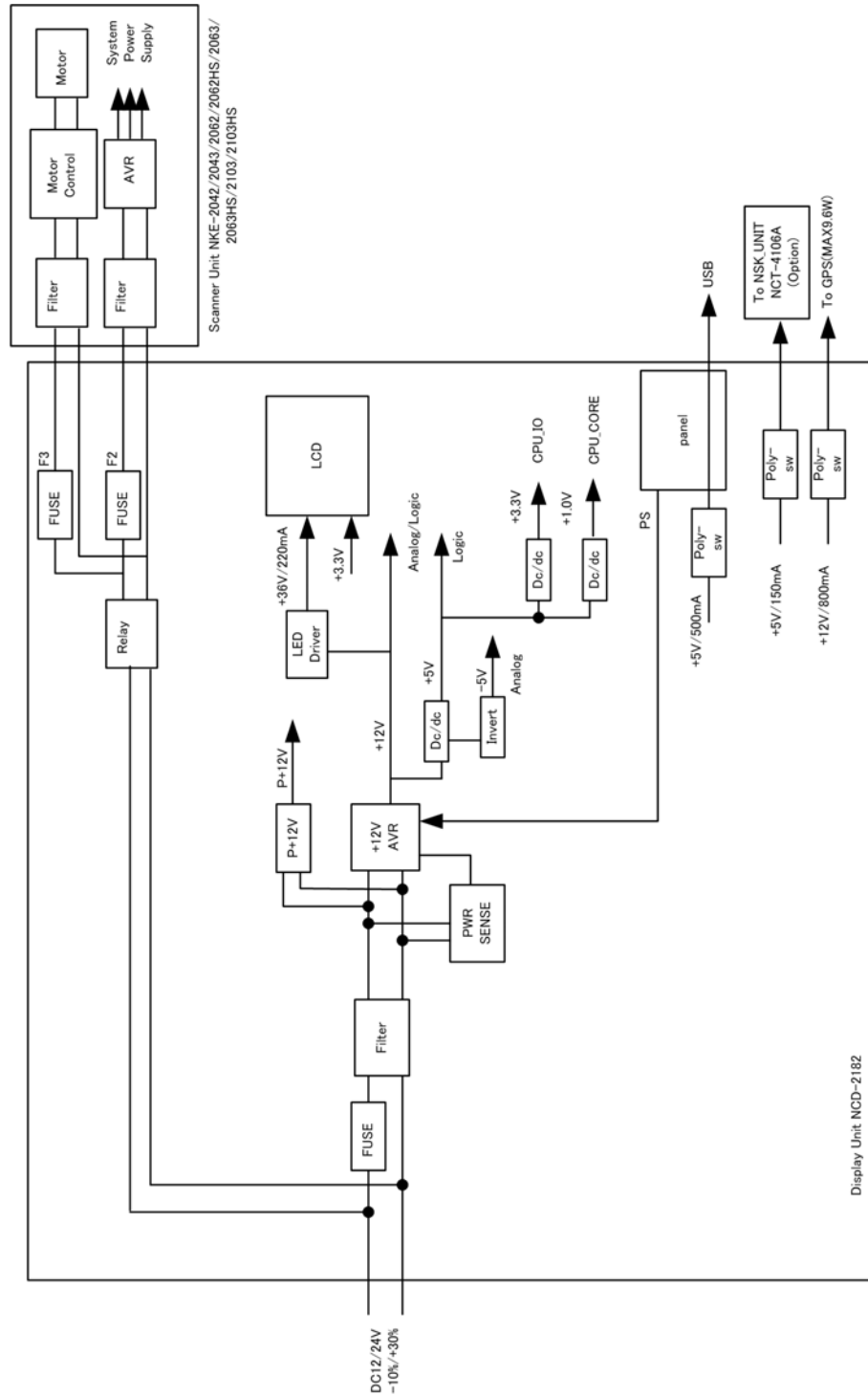

Fig. A10 JMA-3314 INTERCONNECTION DIAGRAM

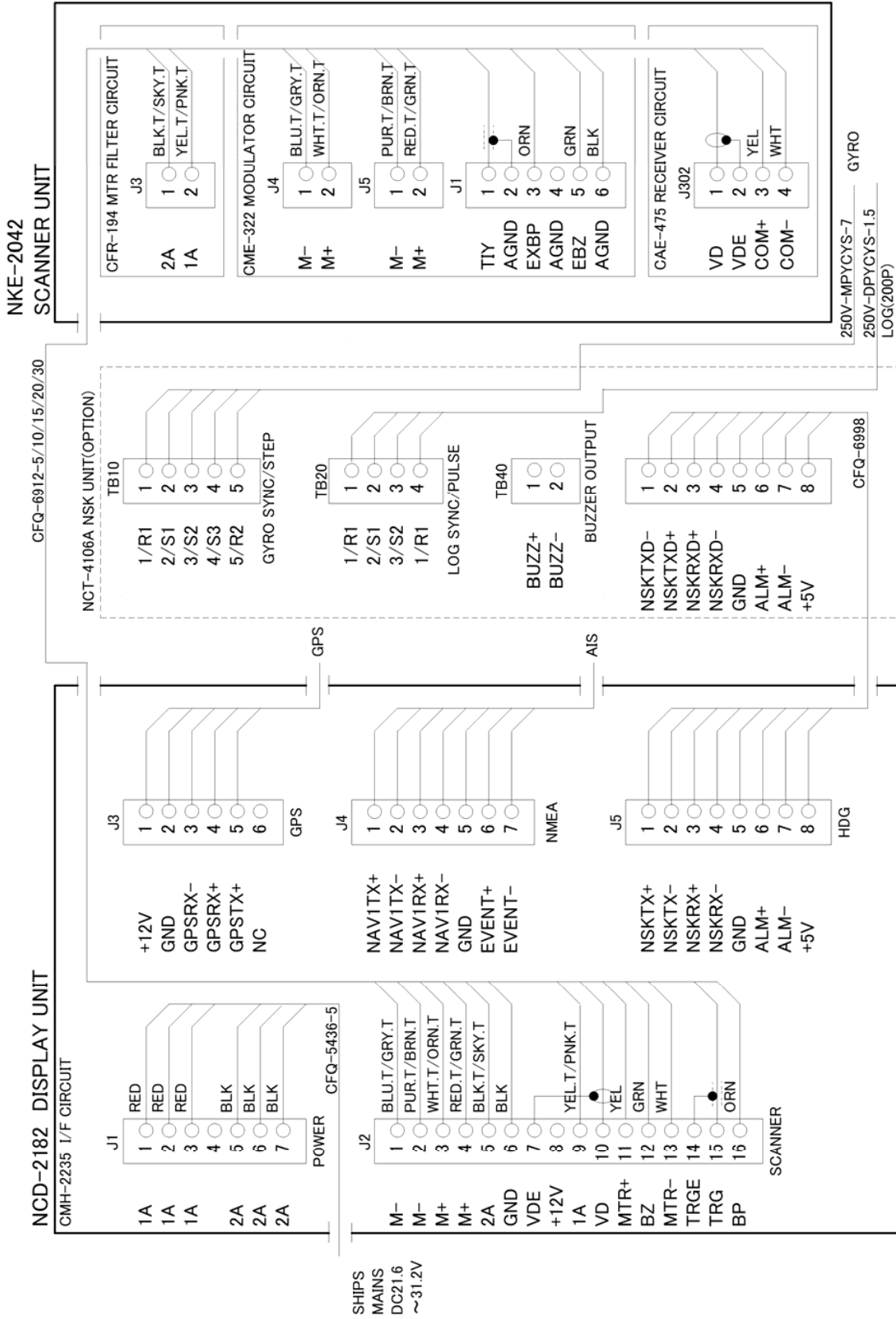
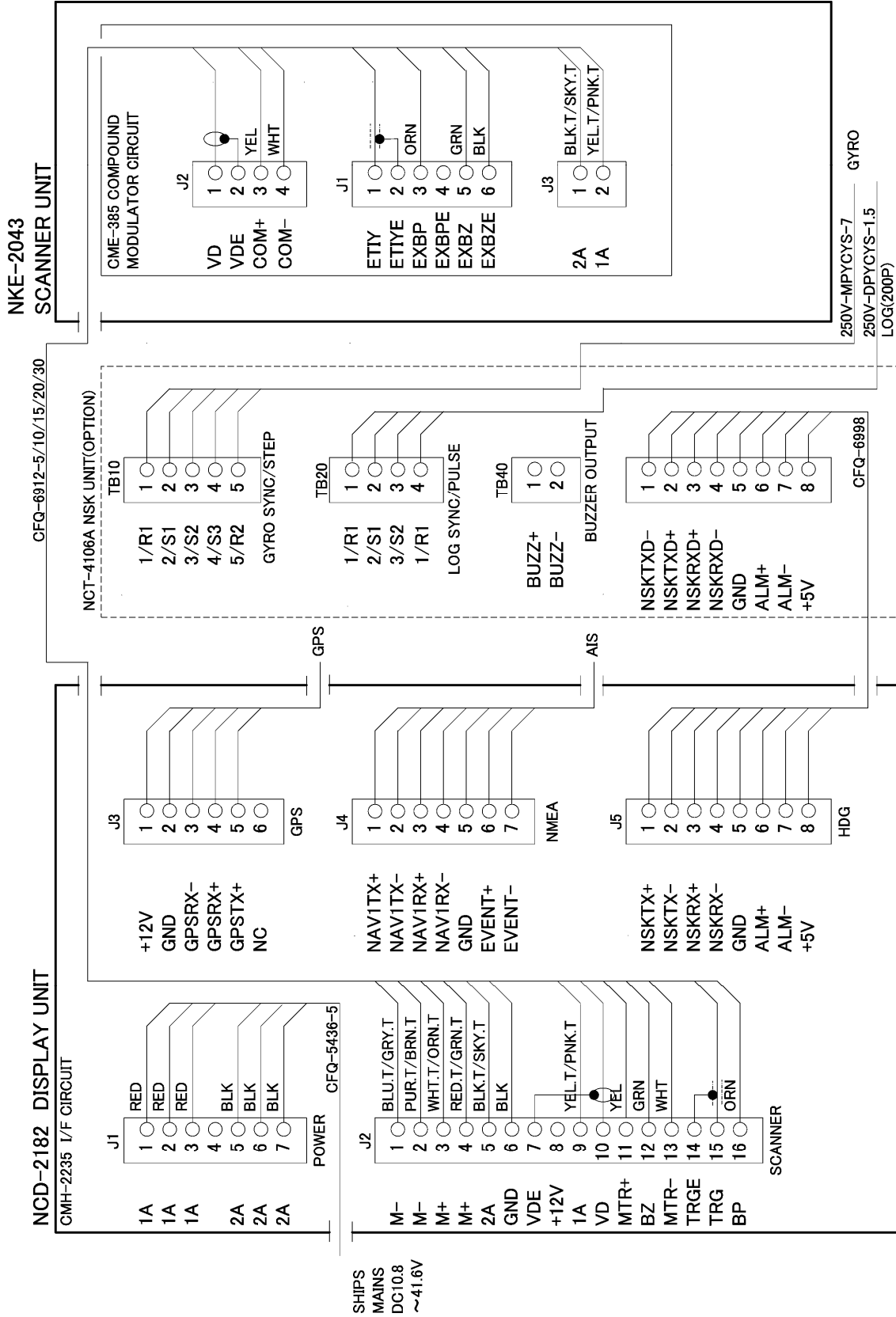

Fig. A11 JMA-3334 INTERCONNECTION DIAGRAM



APPENDIX

INSTRUCTION MANUAL

Fig. A12 JMA-3316/HS INTERCONNECTION DIAGRAM

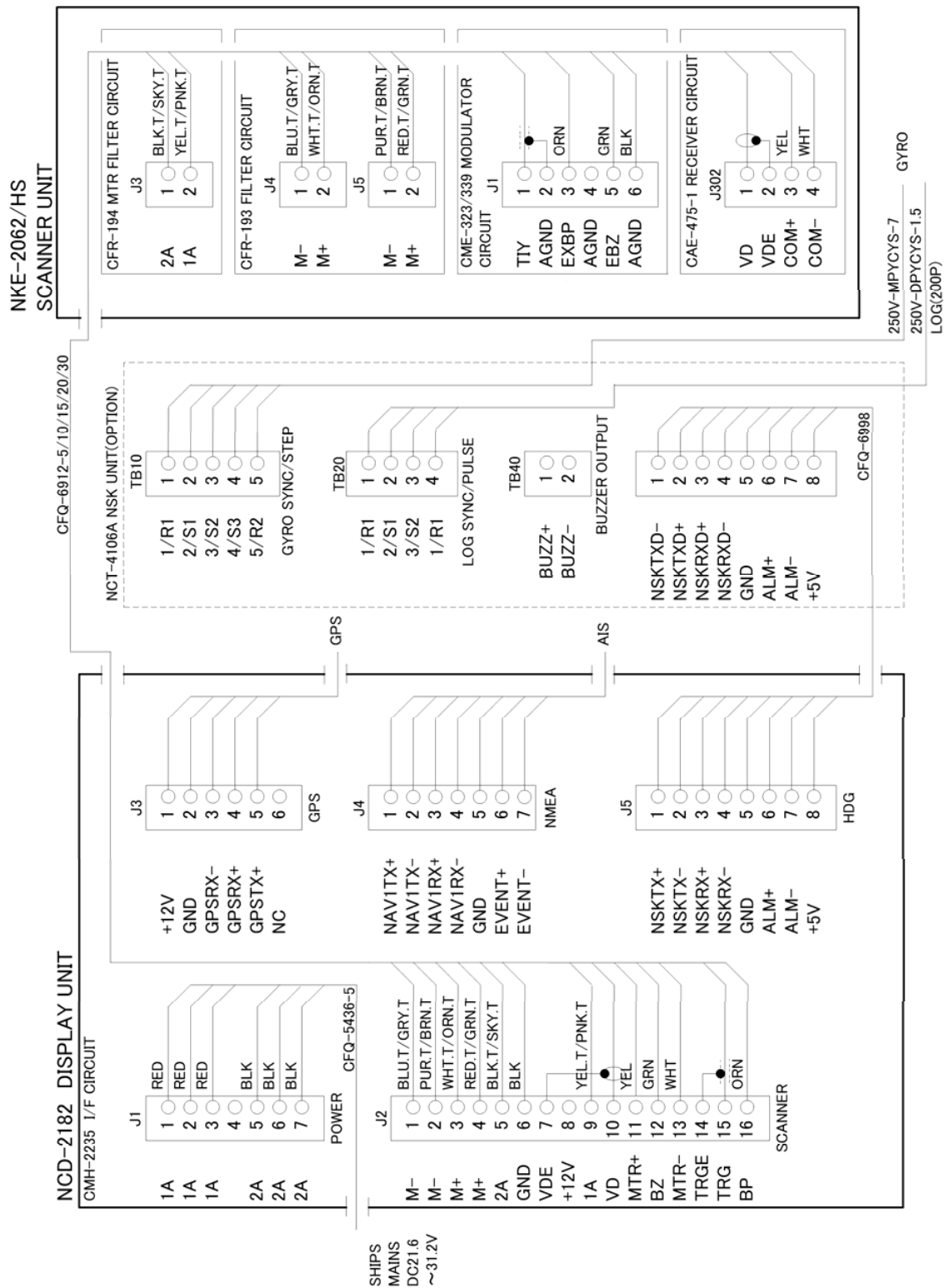

Fig. A13 JMA-3336/HS INTERCONNECTION DIAGRAM

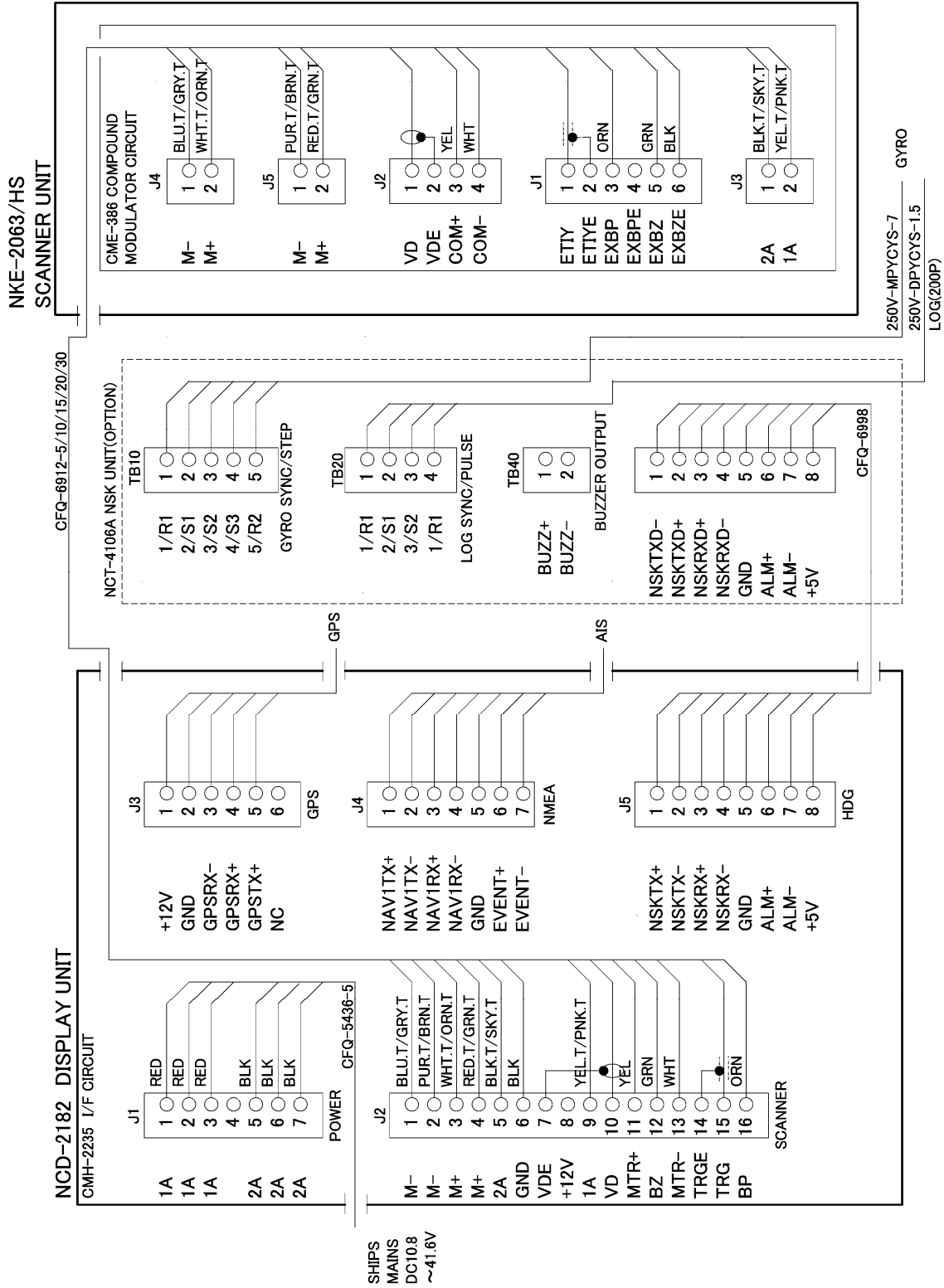
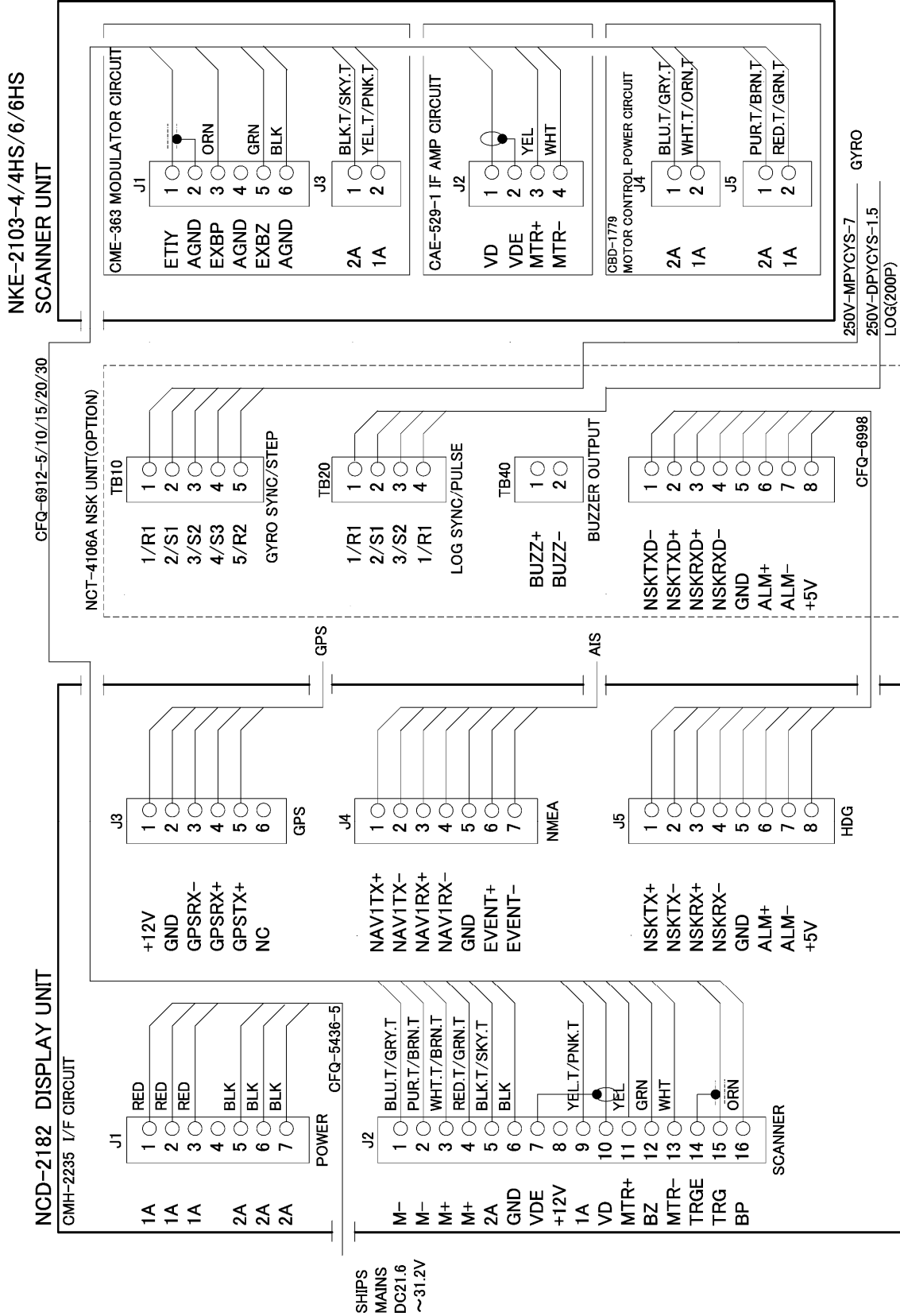

Fig. A14 JMA-3340-4/4HS/6/6HS INTERCONNECTION DIAGRAM



APPENDIX

	AZ/Alarm Zone	Color	White / Green / Orange / Black / Red
		Brilliance	Level1 / Level2 / Level3 / Level4
Day2			
Day3			
Dusk			
Night			
Control	Bearing True/Relative		True / Relative
	User Key	User Key1	Off / VRM1 Unit / VRM2 Unit / Alarm / Display
		User Key2	Off / VRM1 Unit / VRM2 Unit / Alarm / Display
		User Key3	Off / VRM1 Unit / VRM2 Unit / Alarm / Display
Buzzer	Key ACK		0~255
	Operation Error		0~255
	CPA/TCPA		0~255
	AZ/Alarm Zone		0~255
	Target Lost		0~255
	System Alarm		0~255
Output Buzzer	CPA/TCPA		Off / On
	AZ/Alarm Zone		Off / On
	Target Lost		Off / On
	System Alarm		Off / On
	Out of Range		Off / On
Function Setting	Function1 Setting	Function Enable/Disable	Off / On
		Mode	Standard / Coast / Deepsea / Fishnet / Storm / Calm / Rain / Bird / Long / Buoy / User1 / User2
		IR	Off / Low / Middle / High
		Process	Process Off / 3Scan COREL / 4Scan COREL / 5Scan COREL / Remain / Peak Hold
		Target Enhance	Off / Level1 / Level2 / Level3
		AUTO STC/FTC	Off / AUTO STC / AUTO FTC
		Pulse Length	
		NM Range	
		0.5NM	(NKE-2042) 0.5NM : SP/MP1 0.75/1NM : SP/MP1 1.5NM : SP/MP1 2/3/4NM : MP1/MP2 6/8NM : MP2/LP1 12/16NM : LP1
		0.75/1NM	(NKE-2043) 0.5NM : SP1/MP1 0.75/1NM : SP2/MP1 1.5NM : SP2/MP1/MP2 2/3/4NM : SP3/MP1/MP2 6/8NM : MP2/LP1/LP2 12/16NM : MP2/LP1/LP2
		1.5/2NM	(NKE-2062) 0.5NM : SP/MP1 0.75/1NM : SP/MP1 1.5NM : SP/MP1 2/3/4NM : MP1/MP2 6/8NM : MP2/LP1 12/16NM : LP1
		3/4NM	(NKE-2063) 0.5NM : SP1/MP1 0.75/1NM : SP2/MP1 1.5NM : SP2/MP1/MP2 2/3/4NM : SP3/MP1/MP2 6/8NM : MP2/LP1/LP2 12/16NM : MP2/LP1/LP2
		6/8NM	(NKE-2103) 0.5NM : SP/MP1 0.75/1NM : SP/MP1 1.5NM : SP/MP1/MP2 2/3/4NM : MP1/MP2/LP1 6/8NM : MP2/LP1/LP2 12/16NM : MP2/LP1/LP2
		12/16NM	

APPENDIX

	AIS		Off / On
CPA Limit			0.1~9.9nm
TCPA Limit			1~99min
CPA Ring			Off / On
Target Number Display			
	TT		Off / On
	AIS		Off / On
Target Number Allocation			
	TT		0~90
	AIS		0~50
	Own Ship's		0~99
	Cursor		0~99
ALR Alarm From AIS			Off / On
AIS Display Target			20 / 30 / 40 / 50
AIS Destination Ship			0~99999999
AIS Retrieved Vessel			
	MMSI Number Setting		
		Retrieved Vessel info #1	0~99999999
		Retrieved Vessel info #2	0~99999999
		Retrieved Vessel info #3	0~99999999
		Retrieved Vessel info #4	0~99999999
		Retrieved Vessel info #5	0~99999999
		Retrieved Vessel info #6	0~99999999
		Retrieved Vessel info #7	0~99999999
		Retrieved Vessel info #8	0~99999999
		Retrieved Vessel info #9	0~99999999
		Retrieved Vessel info #10	0~99999999
AIS Filter			0,0~72.0NM
File Operation			
	Save	AIS Retrieved Vessel	
	Load	AIS Retrieved Vessel	
	Erase	AIS Retrieved Vessel	
RADAR Alarm			
	RADAR Alarm1 Level		Level1 / Level2 / Level3 / Level4
	RADAR Alarm2 Level		Level1 / Level2 / Level3 / Level4
Plot			
	Waypoint Display		Off / On
	Mark		
	Mark Size		Small / Large
	Display Mark Color	All	All / Individual
		White	Off / On
		Cyan	Off / On
		Blue	Off / On
		Green	Off / On
		Yellow	Off / On
		Magenta	Off / On
		Red	Off / On
	Display Mark Type	All	All / Individual
		X	Off / On
		+	Off / On
		Y	Off / On
		☒	Off / On
	Mark List		
Line			
	Display Line Color	All	All / Individual
		White	Off / On
		Cyan	Off / On
		Blue	Off / On
		Green	Off / On
		Yellow	Off / On
		Magenta	Off / On
		Red	Off / On
	Display Line Type	All	All / Individual
		—	Off / On
		- - - -	Off / On
		- - - -	Off / On
	Line List		
Own Track			
	Display Own Track Color	All	All / Individual
		White	Off / On
		Cyan	Off / On
		Blue	Off / On
		Green	Off / On
		Yellow	Off / On
		Magenta	Off / On
		Red	Off / On
	Display Own Track Type	All	All / Individual

APPENDIX

Scanner	Slope Correction			0.0~2.0
	PRF Fine Tuning			0~31
	Stagger Trigger	The options vary depending on the scanner.		Off / On
	Scanner Rotation Speed			0~7
		SP		0~7
		MP1		0~7
		MP2		0~7
		LP1		0~7
		LP2		0~7
		LP3		0~7
	PRF		Normal / Economy / High Power	
	Safety Switch		TX-Off / Standby / TX-On / Ignore Error	
	Tune Peak Adjustment		0~127	
	Tune Indicator		0~127	
I/F Device	Set GYRO			0~359.9°
	Heading Equipment			AUTO / GYRO / Compass / GPS / Manual
	Manual Heading			0~359.9°
	Speed Equipment			GPS / Log / 2Log / Manual
	Manual Speed			0~100.0kn
	MAG Compass Setting			Off / On
		Heading Correction		W9.9~E9.9°
		Correct Value		
COM Port Setting	Baud Rate			
		GYRO/Compass		AUTO / 4800bps / 38400bps
		GPS		AUTO / 4800bps / 38400bps
		NMEA1		AUTO / 4800bps / 38400bps
		NMEA2		AUTO / 4800bps / 38400bps
	RX Sentence	GPS (LL)		Off / On
			GGA	Off / On
			RMC	Off / On
			RMA	Off / On
			GNS	Off / On
		GLL	Off / On	
	GPS (COG/SOG)			
		RMC	Off / On	
		RMA	Off / On	
		VTG	Off / On	
	Heading			
		THS	Off / On	
		HDT	Off / On	
		HOG	Off / On	
		HDM	Off / On	
		VHW	Off / On	
	Depth			
		DPT	Off / On	
		DBS	Off / On	
		DBT	Off / On	
		DBK	Off / On	
	Wind			
		MWV	Off / On	
		VWT	Off / On	
		VWR	Off / On	
	WPT			
		RMB	Off / On	
		BWC	Off / On	
		BWR	Off / On	
RX Port	GPS			AUTO / GYRO/Compass / GPS / NMEA1 / NMEA2
	Log			AUTO / GYRO/Compass / GPS / NMEA1 / NMEA2
	2Log			AUTO / GYRO/Compass / GPS / NMEA1 / NMEA2
	Depth			AUTO / GYRO/Compass / GPS / NMEA1 / NMEA2
	Temperature			AUTO / GYRO/Compass / GPS / NMEA1 / NMEA2
	Wind			AUTO / GYRO/Compass / GPS / NMEA1 / NMEA2
	WPT			AUTO / GYRO/Compass / GPS / NMEA1 / NMEA2
	Rate of Turn			AUTO / GYRO/Compass / GPS / NMEA1 / NMEA2
	Rudder			AUTO / GYRO/Compass / GPS / NMEA1 / NMEA2
TX Port	ITTM			Off / GYRO/Compass / GPS / NMEA1 / NMEA2
	TLL			Off / GYRO/Compass / GPS / NMEA1 / NMEA2
	ITD			Off / GYRO/Compass / GPS / NMEA1 / NMEA2
	TLB			Off / GYRO/Compass / GPS / NMEA1 / NMEA2
	GGA			Off / GYRO/Compass / GPS / NMEA1 / NMEA2
	GLL			Off / GYRO/Compass / GPS / NMEA1 / NMEA2
	RMC			Off / GYRO/Compass / GPS / NMEA1 / NMEA2
	GNS			Off / GYRO/Compass / GPS / NMEA1 / NMEA2
	VTG			Off / GYRO/Compass / GPS / NMEA1 / NMEA2
	OSD			Off / GYRO/Compass / GPS / NMEA1 / NMEA2
	RSD			Off / GYRO/Compass / GPS / NMEA1 / NMEA2
	THS			Off / GYRO/Compass / GPS / NMEA1 / NMEA2

	HDT		Off / GYRO/Compass / GPS / NMEA1 / NMEA2
TX Data Format	TX Interval		1~9sec
	NMEA Version		V2.3 / V2.0 / V1.5
	NMEA Talker		Normal / GP
Target Information TX	TX Target		TT / AIS / TT-AIS
	TTM Distance Accuracy		1 / 2 / 3
	TT Average Mode		Off / On
	TT Average Scan		2~10
GPS	GPS Setting	NMEA Version	AUTO / V1.5 / V2.1 / V2.3
		Correction Method	GPS Single / SBAS / Beacon / AUTO
		Fix Mode	2D / 3D / AUTO
		Elevate Mask	5~89°
		HDOP	4 / 10 / 20
		Latitude and Longitude	0~99sec(R34.00~)
		SOG	0~99sec(R34.00~)
		COG	0~99sec(R34.00~)
		Smoothing	0~99sec(R29.04~R33.99) 1~99sec(R26.01~R29.03)
		Smoothing	0sec / 10sec / 40sec
		RAIM Accuracy Level	Off / 10m / 30m / 50m / 100m
		Exclusion Satellite	
			Exclusion Satellite1
		Exclusion Satellite2	0~32
		Exclusion Satellite3	0~32
		Exclusion Satellite4	0~32
		Exclusion Satellite5	0~32
	Exclusion Satellite6	0~32	
	Send Data		
	GPS Adjust		
	Position		
	Antenna Height	0~8191m	
	Time	00:00:00~23:59:59	
	Date	2010/01/01~2099/12/31	
	Master Reset		
	Send Data		

The options vary depending on the version.

APPENDIX

Beacon Setting	Select		AUTO / Manual	
	Frequency		283.5~325.0kHz	
	Baud Rate		50 / 100 / 200 bps	
	Send Data			
	SBAS Setting	Satellite Search		AUTO / Manual
		Ranging		Off / On
		SBAS Satellite Number		120~138
		Send Data		
	Display GPS Receive Status			
	LORAN Setting	Display Time Zone		Off / LORAN A / LORAN C
LORAN A				
Control	LORAN C	Select 1	1S1~2H6 You can set the following values only: 1S1 1S2 1S3 1S4 1S6 1L0 1L1 1L4 1L5 2S0 2S1 2S2 2S3 2S4 2S5 2S6 2S7 2H4 2H5 2H6 (Same as Select 1)	
		Select 2	0.0~9.9μsec	
		TD1 Correction	0.0~9.9μsec	
		TD2 Correction	0.0~9.9μsec	
	Chain	TD1	4990~9990 You can set the following values only: 4990, 5930, 5970, 5980, 5990, 6730, 6731, 6780, 7001, 7030, 7170, 7270, 7430, 7499, 7930, 7950, 7960, 7970, 7980, 7990, 8000, 8290, 8390, 8830, 8930, 8970, 8990, 9007, 9610, 9930, 9940, 9960, 9970, 9980, 9990	
		TD2	0~99	
		TD1 Correction	0.0~9.9μsec	
		TD2 Correction	0.0~9.9μsec	
		Off / On	Off / On	
		Off / On	Off / On	
Soft Key Menu Setting	EBL1		Off / On	
	EBL2		Off / On	
	VRM1		Off / On	
	VRM2		Off / On	
	Parallel Cursor		Off / On	
	Vector Length		Off / On	
	Trails		Off / On	
	AIS		Off / On	
	TT		Off / On	
	Alarm1		Off / On	
	Alarm2		Off / On	
	Display Screen		Off / On	
	TM/RM		Off / On	
	Bearing Mode		Off / On	
	Pulse Length		Off / On	
	Off Center		Off / On	
	Symbol Display		Off / On	
	MOB		Off / On	
	Mark		Off / On	
	Line		Off / On	
	Own Track		Off / On	
	Event Mark		Off / On	
AIS Filter		Off / On		
TLL TX		Off / On		
Soft Key Time Out		0~255sec		
Cross Key Gain		1~5		
Multi Control	EBL		1~5	
	VRM		1~5	
	Common		1~5	
Gain Control	Response Level		1~5	
	Gain MIN Preset		0~127	
	Gain MAX Preset		128~255	
Sea Control	Response Level		1~5	
	Sea MIN Preset		0~127	
	Sea MAX Preset		128~255	
Rain Control	Response Level		1~5	
	Rain MIN Preset		0~127	
	Rain MAX Preset		128~255	
Maintenance	Partial Reset	RADAR Echo		
		Function Setting		
		Basic Adjustment		
		Main Menu		
		Adjust Menu		
		System Information 1		
		System Information 2		
		All Menu		
		All Reset		

System Time Clear			
Scanner Time Clear			
	TX Time Clear		
	Motor Time Clear		
	Scanner to Display Unit		
	Display Unit to Scanner		
Table Update			
	STC Curve		
	Color		
	Initial Value		
		RADAR Echo	
		Function Setting	
		Basic Adjustment	
		Main Menu	
		Adjust Menu	
		System Information 1	
		System Information 2	
		All Menu	
	Insert Language		
	Echo Simulation		
Internal Setting			
	Internal Memory to USB		
		RADAR Echo	
		Function Setting	
		Basic Adjustment	
		Main Menu	
		Adjust Menu	
		System Information 1	
		System Information 2	
		All Menu	
	USB to Internal Memory		
		RADAR Echo	
		Function Setting	
		Basic Adjustment	
		Main Menu	
		Adjust Menu	
		System Information 1	
		System Information 2	
		All Menu	
USB Format			
System Setting			
	Master/Slave/DEMO		Master / Slave / Demo
	Unit		
	Range		NM / km / sm
	Distance		NM / km / sm
	Speed		kn / km/h / mph
	Depth		ft / fm / m / user
	User Depth		0.0001~9.9999m
	Temperature		°C / °F
	Wind		m/s / km/h / kn
	Size/Location Setting		m / ft
Move Own Ship			
	Ship's Move		LL / COG/SOG
Range			
	NM	0.0625NM	Off / On
		0.125NM	Off / On
		0.25NM	Off / On
		1NM	Off / On
		2NM	Off / On
		4NM	Off / On
		8NM	Off / On
		16NM	Off / On
		24NM	Off / On
		32NM	Off / On
		48NM	Off / On
		64NM	Off / On
		72NM	Off / On
	km	0.15km	Off / On
		0.3km	Off / On
		0.5km	Off / On
		1.2km	Off / On
		2km	Off / On
		8km	Off / On
	sm	0.0625sm	Off / On
		0.125sm	Off / On
		0.25sm	Off / On
		1sm	Off / On
		2sm	Off / On
		4sm	Off / On
		8sm	Off / On
		16sm	Off / On

APPENDIX

INSTRUCTION MANUAL

APPENDIX

		24sm	Off / On
		32sm	Off / On
		48sm	Off / On
		64sm	Off / On
		72sm	Off / On
Display Screen			
	Own Vector Line Width		0~5
	Own Outline		Off / On
		On/Off	
		Input Outline Size	
		All Length	0.0~600.0m
		All Width	0.0~200.0m
		GPS Antenna (Length)	0.0~600.0m
		GPS Antenna (Side)	-100.0~+100.0m
		Scanner (Length)	0.0~600.0m
		Scanner (Side)	-100.0~+100.0m
	Barge Outline		Off / On
		On/Off	
		Input Outline Size	
		All Length	0.0~600.0m
		All Width	0.0~200.0m
		Barge Position (Length)	-600.0~+600.0m
		Barge Position (Side)	-200.0~+200.0m
	Bearing Marker		Off / On
		Bearing	0~99°
		Bearing Step	Off / On
	Standby Numeric Display		Off / On
	Operation Numeric Display		Off / On
	Location Change		
		Screen 1	
		Numeric Information (Large)	Off / AXG Course/Speed / Latitude/Longitude
		Numeric Display(0)	Off Own Heading/Speed Own AXG Course/Speed Own Latitude/Longitude ROT/Rudder Depth/Temperature Relative Wind True Wind(Head) Waypoint Bearing/Distance Waypoint Latitude/Longitude Waypoint Arrival Time Cursor Bearing/Distance Cursor Latitude/Longitude Cursor Arrival Time MOB Bearing/Distance MOB Latitude/Longitude MOB Arrival Time EBL1/VRM1 EBL2/VRM2 Parallel Cursor TT Bearing/Distance TT CRS/SPD TT CPA/TCPA AIS Bearing/Distance AIS COG/SOG AIS CPA/TCPA Rate of Turn Rudder Depth Temperature
		Numeric Display(1)	Same options as Numeric Display(0)
		Numeric Display(2)	Same options as Numeric Display(0)
		Numeric Display(3)	Same options as Numeric Display(0)
		Numeric Display(4)	Same options as Numeric Display(0)
		Numeric Display(5)	Same options as Numeric Display(0)
		Numeric Display(6)	Same options as Numeric Display(0)
		Numeric Display(7)	Same options as Numeric Display(0)
		Numeric Display(8)	Same options as Numeric Display(0)
		Numeric Display(9)	Same options as Numeric Display(0)
		Numeric Display(10)	Same options as Numeric Display(0)
		Numeric Display(11)	Same options as Numeric Display(0)
		Numeric Display(12)	Same options as Numeric Display(0)
		Tune Gauge	Off / On
		Pulse Length	Off / On
		Trails	Off / On
		Alarm Area1	Off / On
		Alarm Area2	Off / On
		IR	Off / On
		Target Enhance	Off / On
		Gain/Sea/Rain	Off / On
		Own Ship Trails	Off / On
		Vector Length	Off / On
		Function	Off / On
		Process	Off / On
		Zoom	Off / On
		System Status	Off / On
		Bearing Marker	Off / Ring / Ring/Numeric
		Wide Screen	Standard / Wide

Screen2	Numeric Information (Large)	Off / AXG Course/Speed / Latitude/Longitude
	Numeric Display(0)	* Same options as Screen 1
	Numeric Display(1)	Same options as Numeric Display(0)
	Numeric Display(2)	Same options as Numeric Display(0)
	Numeric Display(3)	Same options as Numeric Display(0)
	Numeric Display(4)	Same options as Numeric Display(0)
	Numeric Display(5)	Same options as Numeric Display(0)
	Numeric Display(6)	Same options as Numeric Display(0)
	Numeric Display(7)	Same options as Numeric Display(0)
	Numeric Display(8)	Same options as Numeric Display(0)
	Numeric Display(9)	Same options as Numeric Display(0)
	Numeric Display(10)	Same options as Numeric Display(0)
	Numeric Display(11)	Same options as Numeric Display(0)
	Numeric Display(12)	Same options as Numeric Display(0)
	Tune Gauge	Off / On
	Pulse Length	Off / On
	Trails	Off / On
	Alarm Area1	Off / On
	Alarm Area2	Off / On
	IR	Off / On
	Target Enhance	Off / On
	Gain/Sea/Rain	Off / On
	Own Ship Trails	Off / On
	Vector Length	Off / On
	Function	Off / On
	Process	Off / On
	Zoom	Off / On
	System Status	Off / On
	Bearing Marker	Off / Ring / Ring/Numeric
	Wide Screen	Standard / Wide
Error Alarm Mask		
Scanner		
Scanner (Time Out)	Alarm Sensitivity	Off / On
	Sensitivity Time	0~999sec
Scanner (Data)	Alarm Sensitivity	Off / On
	Sensitivity Time	0~999sec
Scanner (AZI)	Alarm Sensitivity	Off / On
	Sensitivity Time	0~999sec
Scanner (HL)	Alarm Sensitivity	Off / On
	Sensitivity Time	0~999sec
Scanner (MHV)	Alarm Sensitivity	Off / On
	Sensitivity Time	0~999sec
Scanner (Heater)	Alarm Sensitivity	Off / On
	Sensitivity Time	0~999sec
Scanner (Reverse)	Alarm Sensitivity	Off / On
	Sensitivity Time	0~999sec
Scanner (Video)	Alarm Sensitivity	Off / On
	Sensitivity Time	0~999sec
Scanner (Trigger)	Alarm Sensitivity	Off / On
	Sensitivity Time	0~999sec
Scanner (Fan 1)	Alarm Sensitivity	Off / On
	Sensitivity Time	0~999sec
Scanner (Fan 2)	Alarm Sensitivity	Off / On
	Sensitivity Time	0~999sec
Scanner (Motor)	Alarm Sensitivity	Off / On
	Sensitivity Time	0~999sec
Display Unit		
Display Unit (Video)	Alarm Sensitivity	Off / On
	Sensitivity Time	0~999sec
Display Unit (Trigger)	Alarm Sensitivity	Off / On
	Sensitivity Time	0~999sec
Display Unit (AZI)	Alarm Sensitivity	Off / On
	Sensitivity Time	0~999sec
Display Unit (HL)	Alarm Sensitivity	Off / On
	Sensitivity Time	0~999sec

APPENDIX

INSTRUCTION MANUAL

APPENDIX

Connection Device	Display Unit (DSP)	Alarm Sensitivity	Off / On
		Sensitivity Time	0~999sec
	COM Port	Alarm Sensitivity	Off / On
	Temperature	Alarm Sensitivity	Off / On
		Alarm Sensitivity	Off / On
	Panel1(Time Out)	Alarm Sensitivity	Off / On
		Sensitivity Time	0~999sec
	Panel2(Time Out)	Alarm Sensitivity	Off / On
		Sensitivity Time	0~999sec
	GYRO(Time Out)	Alarm Sensitivity	Off / On
		Sensitivity Time	0~999sec
	Log(Time Out)	Alarm Sensitivity	Off / On
		Sensitivity Time	0~999sec
	GPS(Time Out)	Alarm Sensitivity	Off / On
	Sensitivity Time	0~999sec	
RX Data	GYRO	Alarm Sensitivity	Off / On
		Sensitivity Time	0~999sec
	Compass	Alarm Sensitivity	Off / On
		Sensitivity Time	0~999sec
	Log	Alarm Sensitivity	Off / On
		Sensitivity Time	0~999sec
	2Log	Alarm Sensitivity	Off / On
		Sensitivity Time	0~999sec
	Course/Speed	Alarm Sensitivity	Off / On
		Sensitivity Time	0~999sec
	Depth	Alarm Sensitivity	Off / On
		Sensitivity Time	0~999sec
	Temperature	Alarm Sensitivity	Off / On
		Sensitivity Time	0~999sec
	Wind	Alarm Sensitivity	Off / On
		Sensitivity Time	0~999sec
	Rate of Turn	Alarm Sensitivity	Off / On
		Sensitivity Time	0~999sec
	Rudder	Alarm Sensitivity	Off / On
		Sensitivity Time	0~999sec
	WPT	Alarm Sensitivity	Off / On
		Sensitivity Time	0~999sec
	LAT/LON	Alarm Sensitivity	Off / On
		Sensitivity Time	0~999sec
Datum	Alarm Sensitivity	Off / On	
	Sensitivity Time	0~999sec	
Status	Alarm Sensitivity	Off / On	
	Sensitivity Time	0~999sec	
HDOP	Alarm Sensitivity	Off / On	
	Sensitivity Time	0~999sec	
AIS	Alarm Sensitivity	Off / On	
	Sensitivity Time	0~999sec	

INDEX

A

Adjusting scanner2-54
 AIS..... 2-34, 2-73
 AIS Alarm..... 2-127
 AIS Display Target..... 2-128
 AIS filter 2-73, 2-130
 Alarm 4-10, 4-19

B

Basic menu2-75
 Bearing display2-62
 Buzzer volume..... 2-110

C

Circuit block to be repaired.....4-34
 Cursor2-92

D

DirecTrak™..... 2-128
 DISP Screen2-56
 Display2-94
 Display brilliance2-53
 Display color2-53

E

EBL2-22
 Electric bearing lines 2-23, 2-86
 Error log.....4-9
 Event marks.....2-72

F

Fault finding 4-19
 File operations2-146
 Function key 2-112, 3-4
 Fuse.....4-28

H

Hardware information 4-9

I

Included accessories4-30

L

Line monitor.....4-11
 Lines.....2-70

M

Maintenance 4-1
 Major parts.....4-17
 Marker.....2-86
 Marking2-68
 MOB.....2-68

O

Own ship's display position2-66
 Own ship's track2-71

INDEX

P

Panel.....	2-2
Parallel cursor.....	2-26, 2-88
Plotter.....	2-135
Power on/off.....	2-4

R

Radar alarm.....	2-47, 2-134
RADAR Echo.....	2-79, 2-116
Radar trails.....	2-32, 2-84, 2-118
Radar trails display time.....	2-33, 2-84, 2-118
Rain/snow clutter.....	2-11
Range ring.....	2-93

S

SART.....	3-8
Scanner information.....	4-8
Screen Display.....	2-1
Sea clutter.....	2-8
Self test.....	4-12
Sensitivity adjustment.....	2-6
Soft key.....	2-14
Special parts.....	4-33

Symbol DISP.....	2-67
System information.....	4-7
System time.....	4-8

T

Target number display.....	2-125
Timed TX.....	2-153
TLL TX.....	2-74
Transmitter pulse length.....	2-64
Trouble shooting.....	4-30
True/relative motion.....	2-60, 2-107
TT.....	2-39

U

User key.....	2-108
---------------	-------

V

Vector.....	2-29, 2-125
VRM.....	2-24

W

Waypoint mark.....	2-135
--------------------	-------

アスベストは使用していません
Not use the asbestos

CODE No.7ZPRD0787

For further information, contact:

JRC *Japan Radio Co., Ltd.*
Since 1915

URL <http://www.jrc.co.jp>

Marine Service Department

Telephone : +81-3-3492-1305

Facsimile : +81-3-3779-1420

e-mail : tmisc@jrc.co.jp

AMSTERDAM Branch

Telephone : +31-20-658-0750

Facsimile : +31-20-658-0755

e-mail : service@jrceurope.com

SEATTLE Branch

Telephone : +1-206-654-5644

Facsimile : +1-206-654-7030

e-mail : marineservice@jrcamerica.com

01ETM

ISO 9001, ISO 14001 Certified

©NOV. 2011 Edition 4 JRC

Printed in Japan