

## To change parallel index line intervals

### Procedures

- 1 Put the cursor on near the end of line, and press the [ENT] key.

When the cursor is moved there, it will turn into "↔" and PI will be displayed at the upper right of the cursor. The parallel index lines become operable when the [ENT] key is pressed.

- 2 Move the cursor to the interval to be set.

The parallel index lines interval will change as the cursor moves.  
If Individual is selected for Operation Mode, the parallel index lines move.

- 3 Press the [ENT] key.

The parallel index lines will be fixed.

**4**

## To change the end points of parallel index lines

If Individual is selected for Operation Mode, the length of parallel index lines can be changed.

### Procedures

- 1 Put the cursor on the end point of parallel index lines, and press the [ENT] key.

When the cursor is moved there, it will turn into "↔" and PI will be displayed at the upper right of the cursor. The parallel index lines become operable when the [ENT] key is pressed.

- 2 Move the cursor to the position to be set.

The position of the end point will change as the cursor moves.

- 3 Press the [ENT] key.

The parallel index lines will be fixed.

# 4.2 MEASUREMENT OF RANGE AND BEARING

## 4.2.1 Measurement with Cursor Position (Cursor)

### Procedures

- 1 Make sure of the target echoes on the radar display.
- 2 Move the cursor to the target.

The bearing and range of the target will be shown in the Cursor bearing / range (upper right of the display on page 2-3). The range is a distance from the own ship's position.

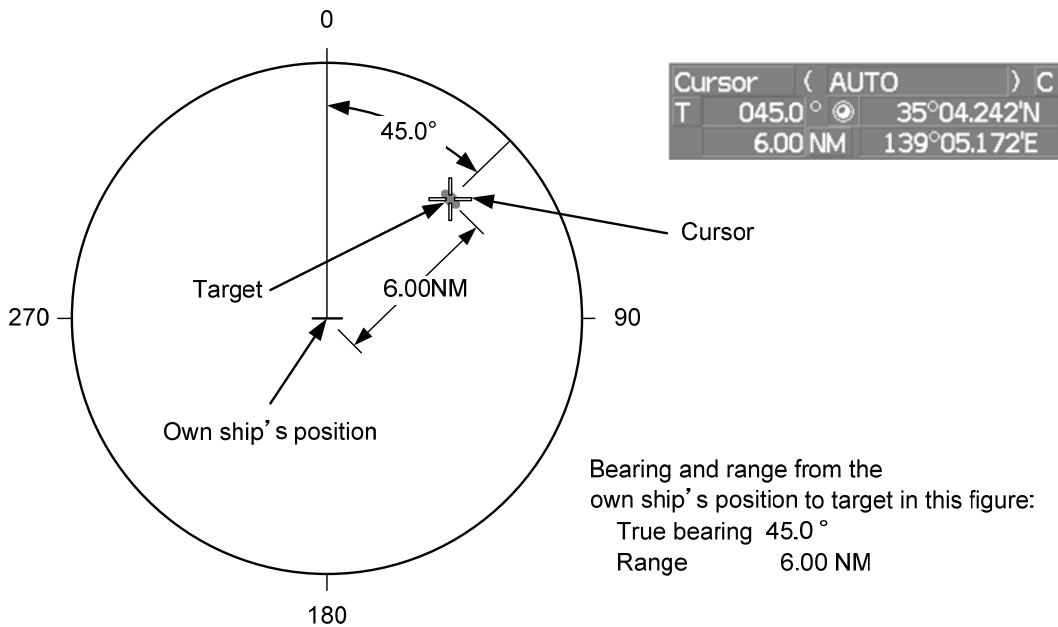

### To set a cursor bearing numeric value mode

Determine whether to display a cursor bearing in true or relative bearing mode.

### Procedures

- 1 Put the cursor on the Cursor bearing numeric value indication true / relative switching (upper right of the display ④ on page 2-19), and press the [ENT] key.

The selected mode is switched as shown below each time the [ENT] key is pressed.

**T** ⇒ **R** ⇒ **T**

**T** :Cursor bearing is displayed in true bearing mode.

**R** :Cursor bearing is displayed in relative bearing mode.

## 4.2.2 Measurement with Electronic Bearing Line and Variable Range Marker [EBL] [VRM]

### Procedures

#### 1 Press the [EBL1] key.

The display in the EBL1 adjustment (upper right of the display ⑤ on page 2-19) will be highlighted, and EBL1 will be shown with a dotted line on the PPI display.

#### 2 Move the EBL1 to the target by turning the [EBL] dial.

The EBL1 bearing will be shown in the EBL1 bearing (upper right of the display on page 2-3).

The EBL1 bearing is the bearing of the target.

#### 3 Press the [VRM1] key.

The display in the VRM1 adjustment (upper right of the display ⑥ on page 2-19) will be highlighted, and VRM1 will be shown with a dotted line on the PPI display.

#### 4 Move the VRM1 to the target by turning the [VRM] dial.

The range of VRM1 from the own ship's position will be shown in the VRM1 range (upper right of the display on page 2-3).

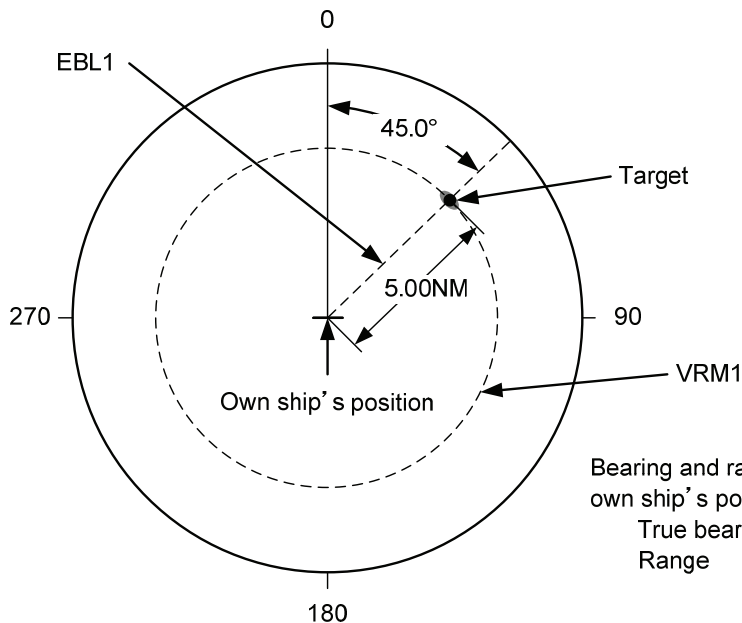

EBL1 T	045.0	°	C
VRM1	5.00	NM	
EBL2 T		°	
VRM2		NM	
		PI	

Bearing and range from the own ship's position to target in this figure:  
 True bearing 45.0°  
 Range 5.00 NM

## 4.2.3 Measurement with Two Arbitrary Points

### Procedures

- 1 Press the [EBL2] key.

The display in the EBL2 adjustment (upper right of the display ⑦ on page 2-19) will be highlighted, and EBL2 will be shown on the PPI display.

- 2 Press the [EBL] dial to select **C** for the EBL2 starting point mode switching (upper right of the display ⑫ on page 2-19).

- 3 Put the cursor on the point A of the two points between which measurement is made, and press the [ENT] key.

Refer to the figure below.

- 4 Move the EBL2 to the other point B by turning the [EBL] dial.

Refer to the figure below.

- 5 Press the [VRM2] key.

When VRM2 is selected,  (intersection marker) will appear on the dotted line of EBL2.

- 6 Move the intersection marker on the dotted line to point B by turning the [VRM] dial.

The range and bearing between the two points will be shown in the VRM2 range and EBL2 bearing (upper right of display on page 2-3).

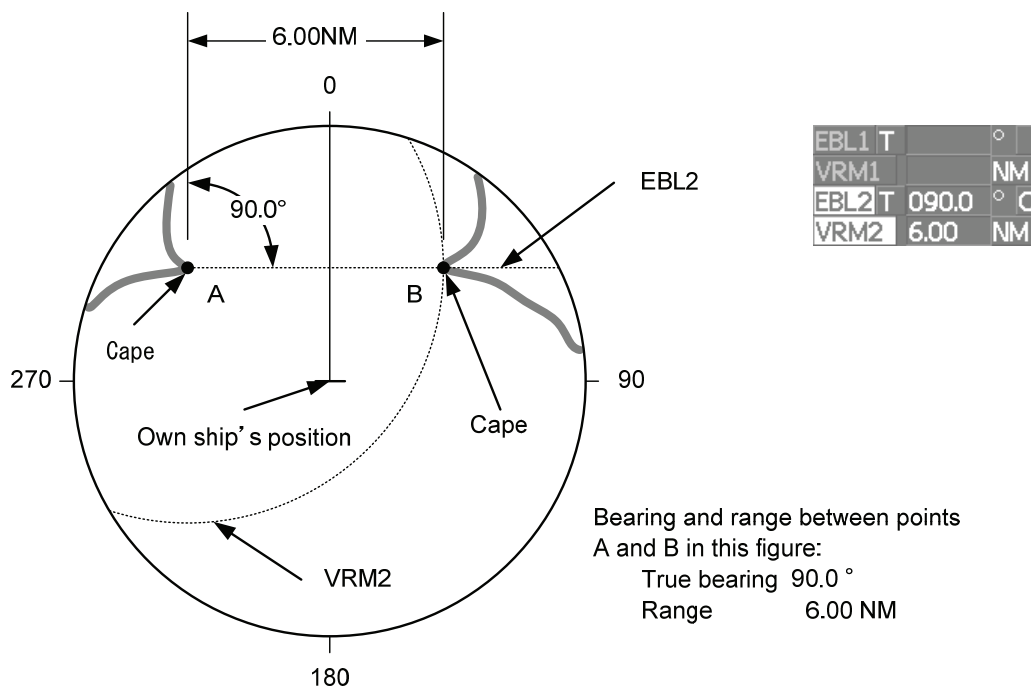

Similarly, EBL1 can also be used for measuring the bearing and range between two points. In this case, perform the above procedure reading EBL2 as EBL1 and VRM2 as VRM1.

# SECTION 5

## OPERATION OF TARGET TRACKING AND AIS

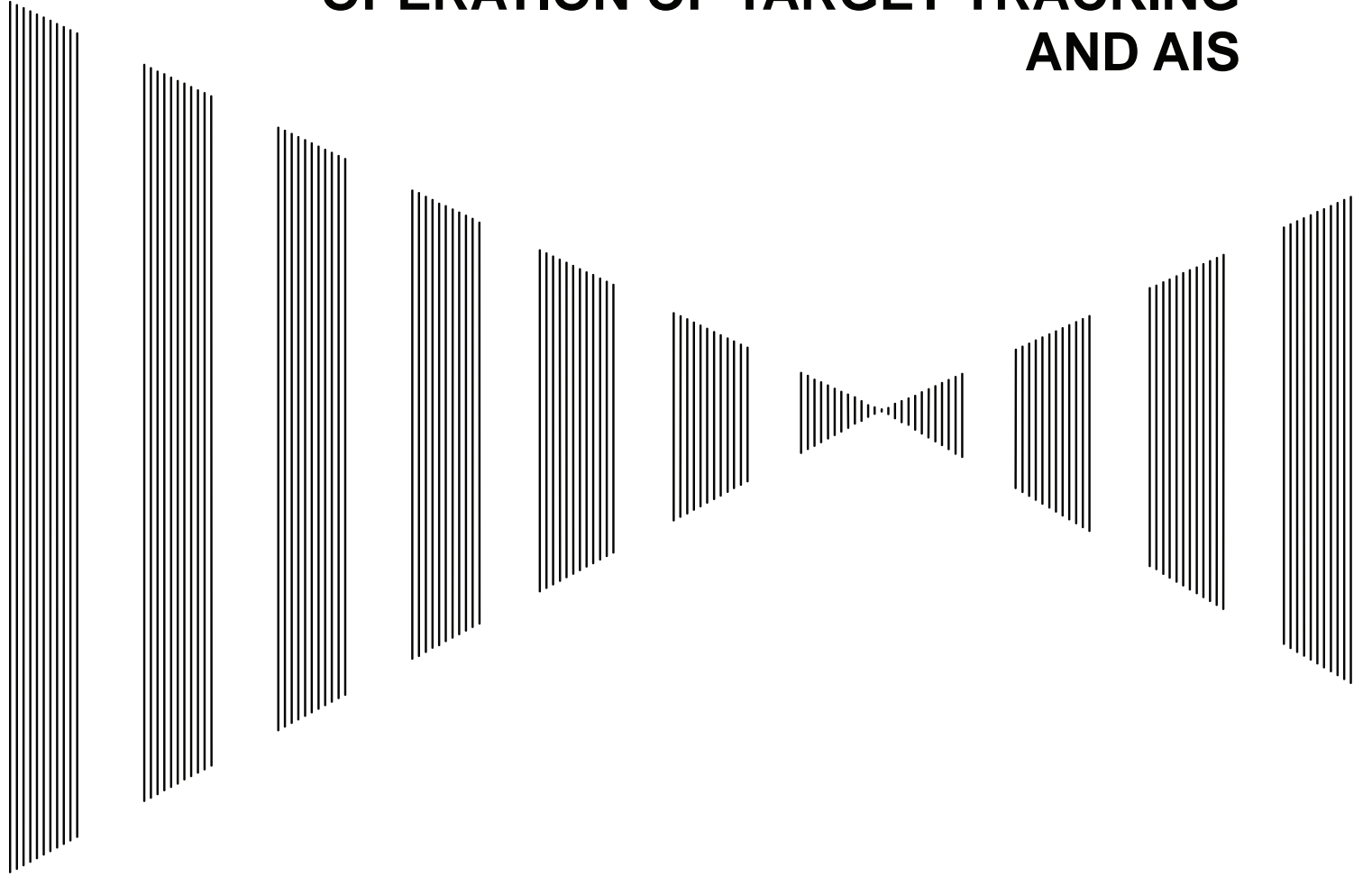

<b>5.1</b>	<b>PREPARATION .....</b>	<b>5-2</b>
<b>5.2</b>	<b>TARGET TRACKING OPERATION.....</b>	<b>5-16</b>
<b>5.3</b>	<b>AIS OPERATION .....</b>	<b>5-30</b>
<b>5.4</b>	<b>DECISION OF TARGETS AS IDENTICAL (ASSOCIATION).....</b>	<b>5-40</b>
<b>5.5</b>	<b>ALARM DISPLAY .....</b>	<b>5-42</b>
<b>5.6</b>	<b>TRACK FUNCTION .....</b>	<b>5-46</b>
<b>5.7</b>	<b>TRIAL MANEUVERING (TRIAL MANEUVER) .....</b>	<b>5-56</b>

---

# USAGE OF TARGET TRACKING FUNCTION

## Attention

- There are the following limitations on use of the target acquisition and target tracking functions.

### [I] Resolution between adjacent targets and swapping during automatic target tracking

Depending on the particular distance and echo size, resolution between adjacent targets during automatic target tracking usually ranges somewhere between 0.03 to 0.05 NM. If multiple targets approach each other, resolution will become about 0.05 NM and this may cause the system to regard them as one target and thus to swap them or lose part of them. Such swapping or loss of targets may also occur if the picture of the target being tracked is affected by rain/snow clutter returns or sea clutter returns or moves very close to land.

### [II] Intensity of echoes and the target tracking function

The intensity of echoes and the tracking function have a relationship, and thus the target will be lost if no echoes are detected during six scans in succession. If a lost target exists, therefore, radar gain must be increased to support detection of the target. If, however, radar gain is increased too significantly, sea clutter returns or other noise may be erroneously detected and tracked as a target, and resultingly, a false alarm may be issued.

### [III] Adverse effects of error sources on automatic tracking

To execute accurate tracking, it becomes necessary first to appropriately adjust the [GAIN], [SEA] and [RAIN] dials of the radar so that the target to be acquired and tracked is clearly displayed on the radar display. Inappropriate settings of these adjustments reduce the reliability / accuracy of automatic tracking.

# 5.1 PREPARATION

This section explains the features of the target tracking and AIS functions, and the initial setting for using each function.

## Target Tracking Function (Option)

The target tracking function calculates the course and speed of a target by automatically tracking the target's move.

The target tracking function enables the automatic acquisition of targets by using the automatic acquisition zone function.

The target tracking function also enables the simulation of the ship maneuvering method to avoid collisions by using the trial maneuver function. (NCA-877WA)

If the mode is ground stabilization, SOG/COG used for own ship's information in target tracking. If the mode is sea stabilization, SPD (speed through the water) / HDG (heading) used for own ship's information in target tracking.

	Normal edition NCA-877A	High performance edition NCA-877WA
Maximum number of targets that can be tracked	30	100
Trial maneuver function	Not provided	Provided

**Note:** ARPA Process Unit (NCA-877WA) or ATA Process Unit (NCA-877A) must be fitted on ships compliant to IMO.

## AIS (Automatic Identification System) function (Option)

The AIS function shows the target's information on the radar display, using other ship's information sent out from the AIS unit.

**Note:** AIS Process Unit must be fitted on ships compliant to IMO.

## 5.1.1 Collision Avoidance

### Problems of Collision Avoidance in Navigation

Marine collision avoidance is one of the problems that have been recognized from of old. Now, it will be described briefly who the collision avoidance is positioned among the navigational aid problems.

The navigation pattern of all mobile craft constitutes a system with some closed loops regardless of the media through which the mobile craft travels, whether air, water, the boundary between air and water, or space. This pattern consists of two closed loops in principle, one of which is a collision with another mobile craft and the other is a loop of finding a right and safe way to reach a predetermine destination. Fig. 5-1 shows the conceptual diagram of navigation pattern by MR. E.W. Anderson. The closed loop of collision avoidance is shown on the left side and the closed loop of finding a right course on the right side.

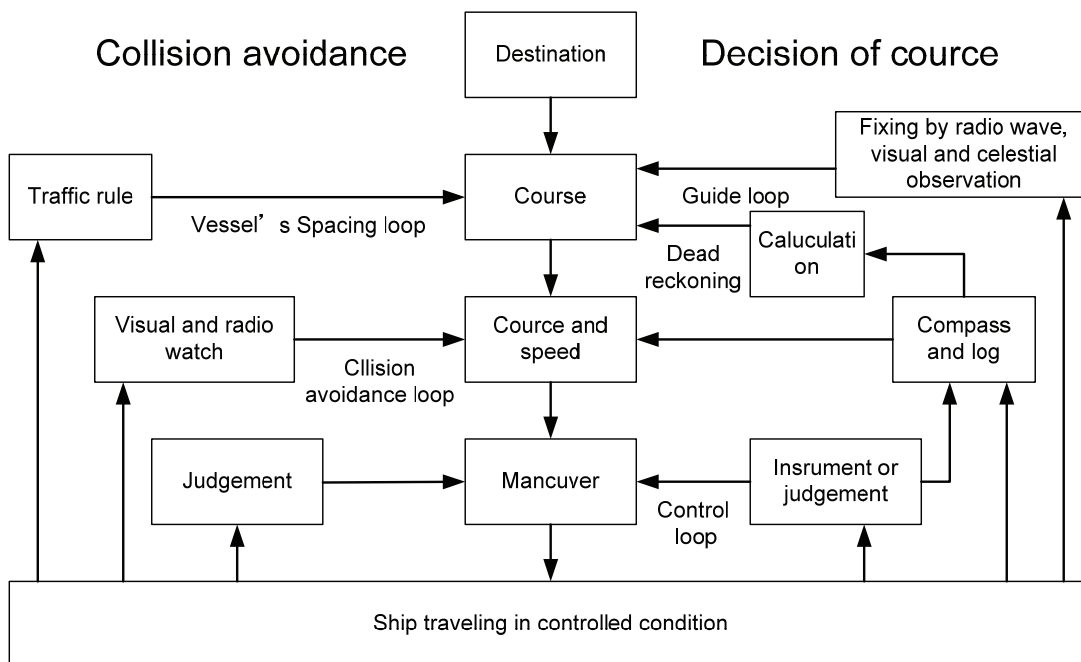

Fig. 5-1 Navigation Pattern

### Marine Accidents and Collisions

Among marine accidents, collision accidents have been highlighted as the tonnages and speeds of ships become higher along with the increase in traffic at sea. If a tanker carrying dangerous articles such as crude oil collides with any other vessel, then not only the vessels involved with the accident but other vessels in the vicinity, port facilities, inhabitants in the coastal area as well as marine resources may also suffer immeasurable damages and troubles. Collision accidents have a high percentage of the marine accidents that have occurred in recent years. To cope with these problems, any effective measures are needed and some equipment to achieve collision avoidance requirements have been developed at rapid strides.



## Basic Concept of Collision Avoidance

There are two aspects in collision avoidance: collision prediction and avoidance. Collision prediction is to predict that two or more vessels will happen to occupy the same point at the same time, while collision avoidance is to maneuver vessels not to occupy the same point at the same time.

In practical operation of vessels, a spot of collision has to be deemed to be a single point but a closed zone. This closed zone is conceptually defined as a CPA (Closest Point of Approach). In collision prediction, the time to be taken until a ship reaches the CPA is defined as a TCPA (Time to CPA).

Fig. 5-2 shows a diagram caked "Collision Triangle".

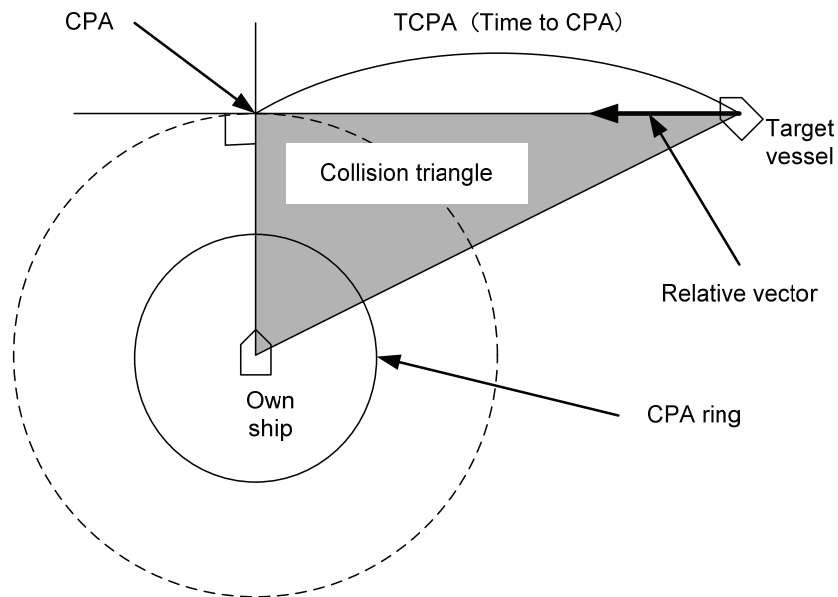

Fig. 5-2 Collision Triangle

---

## Relative Vector and True Vector

From two points of view, collision prediction and avoidance, it is necessary to obtain the relative vector of other ship for prediction and the true vector of other ship for collision avoidance in order to grasp other ship's aspect. The relationship between the relative vector and true vector is shown in Fig. 5-3.

Both rough CPA and TCPA can be obtained easily from the relative speed vector of other ship. This method has an advantage that the risks of collision with all other ships within the radar range can be seen at a glance. On the other hand, the course and speed of other ship can easily be obtained from its true speed vector, enabling other ship's aspect to be seen at a glance. Thus, the aspects of other ships (transverse, outsail, parallel run, reverse run, etc. ) as described in the act of prevention of collision at sea can be readily grasped. If there is a risk of collision with other ship, the operator can determine which rule to be applied and how to operate own ship.

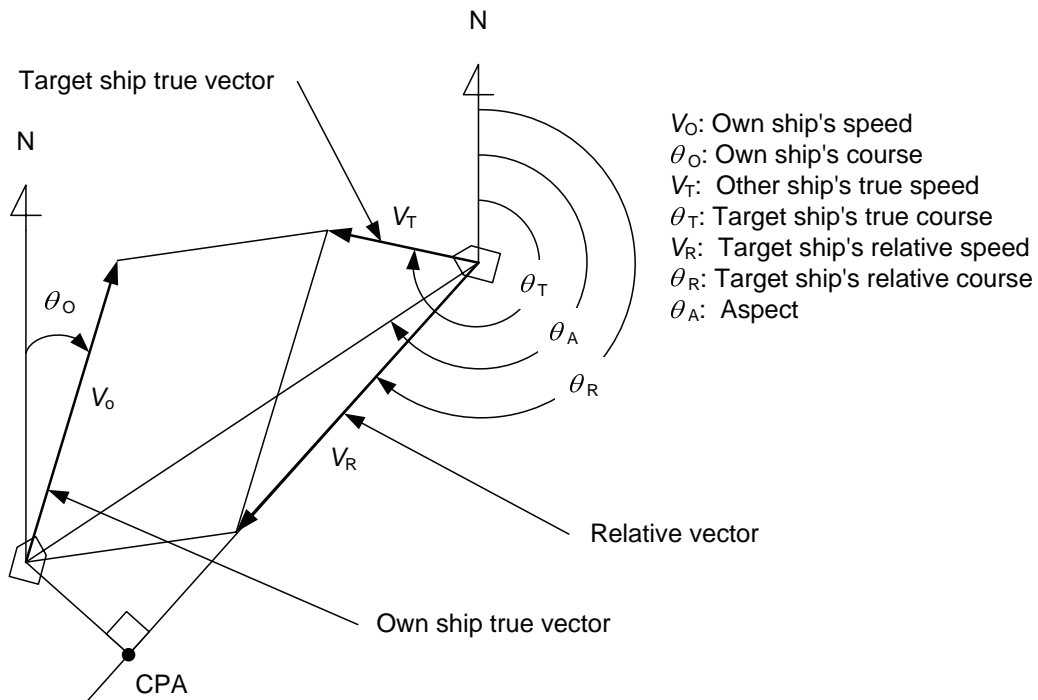



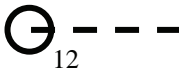

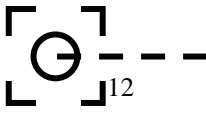

Fig. 5-3 Relative Vector and True vector

## Radar and Collision Avoidance





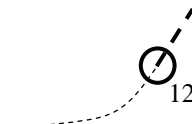

Radar is still playing an important roll for collision prevention and positioning. A plotter is used to further enhance the radar functionality. The plotter is capable of plotting other positions of other ships in 3 to 6 minute intervals to monitor their movement. The plots of other ships represent their tracks relative to own ship, and it is shown whether there is a risk of collision, namely CPA and TCPA can be obtained. This method using a plotter is fairly effective, but the number of target ship, which is manually plotted, is limited and it takes several minutes to measure those.

## 5.1.2 Definitions of Symbols

### Types and Definitions of Target Tracking Symbols

Vector/Symbol	Definition	Remarks
	Initial acquisition target	This symbol is displayed until the vector is displayed after target acquisition.
	Target acquired in automatic acquisition zone	The alarm sounds. The alarm message (New Target) turns red and blinks. The symbol is red colored.
	Tracked target	
	Dangerous target	The alarm sounds. The alarm message (CPA/TCPA) turns red and blinks. The symbol is turns red, and indicates with X mark.
	Numeric displayed target	When the numeric data is displayed, the target symbol is enclosed in a square.
	Lost target	The alarm sounds. The alarm message (Lost) turns red and blinks. The symbol is turns red, and indicates with X mark.
	Past position	The past positions of an AIS target are displayed as well as the target tracking symbol.
	Target track	The track of another ship as an AIS target is displayed as well as the target tracking symbol.

## Types and Definitions of AIS Target Symbols

Vector/Symbol	Definition	Remarks
	Sleeping target	This symbol is displayed when received data is valid. The direction of the triangle's vertex indicates the target's bow or course.
	Activated target	The heading direction is displayed with a solid line, and the course vector is displayed with a dotted line. The line perpendicular to the heading direction indicates the direction to which the course is to be changed. This line may not be displayed.
	Target acquired in automatic acquisition zone	The alarm sounds. The alarm message (New Target) turns red and blinks.
	Outline display	The outlines of ships are displayed scaled down.
	Numeric displayed target	When the numeric data is displayed, the target symbol is enclosed in a square.
	Dangerous target	The alarm sounds. The alarm message (CPA/TCPA) turns red and blinks. The symbol is turns red, and indicates with X mark.
	Lost target	The alarm sounds. The alarm message (Lost) turns red and blinks. The symbol is turns red, and indicates with X mark.

Up to 300 targets can be displayed in total of activated and sleeping AIS targets. Up to 100 activated AIS targets can be included in the total.

If there are more AIS targets than the allowable maximum, they are displayed in the following priority order:

1. Numeric displayed target
2. Target of which CPA / TCPA is lower than the set value  
(Target as a dangerous ship for which an alarm has occurred)
3. Target in automatic activation zone
4. Activated AIS target
5. Target inside AIS filter
6. Target outside AIS filter

If the number of targets at the same priority level exceeds the allowable maximum, they are displayed in the following priority order:

1. Association target
2. Activated AIS target
3. Sleeping AIS target

The vector of an AIS target is to be displayed with a vector over ground or over water, depending on the speed sensor setting and current offset setting. The type of the currently displayed vector can be confirmed by viewing the setting of the stable mode.

When **GND** is displayed for the stability mode (upper left of the display on page 2-2):  
Vector over ground

When **Sea** is displayed for the stability mode (upper left of the display on page 2-2):  
Vector over water

When the vector of an AIS target is displayed with a vector over water, the system has converted the AIS target's vector over ground to the vector over water according to the data received from the AIS and the own ship's information.



**Note:** When the AIS target's symbol is activated but the vector is not displayed, the following are probable causes of the trouble:

COG/SOG is not yet input from the GPS.

The selected speed sensor is malfunctioning.

## Types and Definitions of Association Target Symbols

When a tracked target and an AIS target are decided as identical, it is displayed with either of the following symbols:

Vector/Symbol	Definition	Remarks
 12	Priority for tracked target Association target	
 AIS12	Priority for AIS target Association target	

## Setting of Tracked Target Symbol Display

This function switches the tracking target symbol display between on and off.  
Even if the tracking target symbol display is turned off, the data is retained.

### **Procedures**

- 1 **Move the cursor onto the tracking target symbol display On / Off (TT / AIS information  on page 2-23), and press the [ENT] key.**

The tracking target symbol display will be set to on or off.

## Setting of AIS Target Symbol Display

This function switches the AIS target symbol display between on and off.

### **Procedures**

- 1 **Move the cursor onto the AIS target symbol display On / Off (TT/AIS information  on page 2-23), and press the [ENT] key.**

The AIS target symbol display will be set to on or off.

---

## 5.1.3 Radar Display

### Vector Display

A vector to represent a target's predicted position can be presented in the True vector or Relative vector mode. In each mode, a vector length can be freely changed for a time interval of 1 to 60 minutes. To switch between the true vector mode and relative vector mode, press the [VECT R/T] key.

#### [I] Vector Mode Selection

##### True Vector Mode

In the true vector mode, the direction of a target vector indicates the true course of the target and its vector length is proportional to its speed.

In this mode, own ship's vector is displayed as shown below.

In this mode, the movements of other ships around own ship can be accurately and easily monitored. However, CPA Ring cannot appear in this mode.

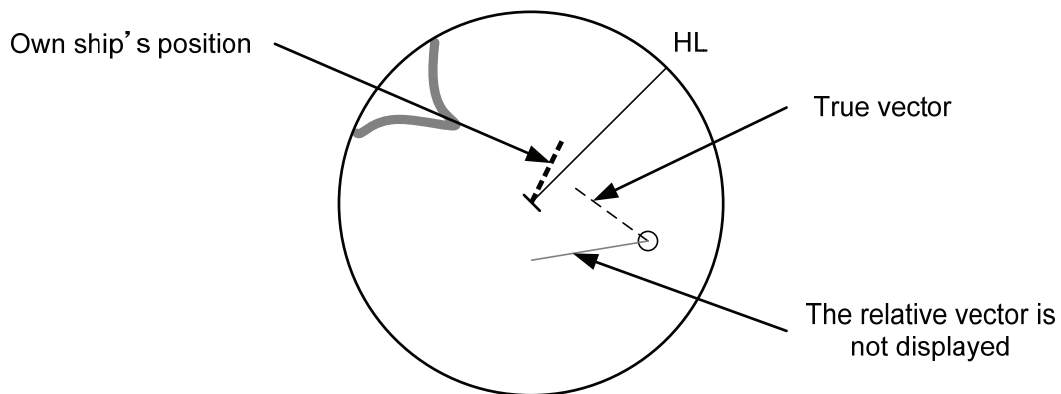

## Relative Vector Mode

The relative vector does not represent the true motion of the target, but its relative relation with own ship. This means that a target with its relative vector directed to own ship (passing through the CPA Limit ring) will be a dangerous target. In the Relative Vector mode, it can be seen at a glance where the CPA Limit of the dangerous target is.

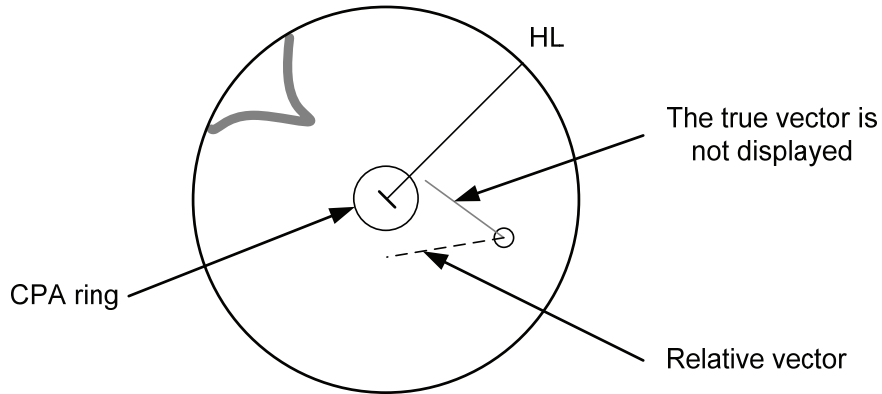

Therefore, the True / Relative mode shall optionally be used for the purpose of observation: the True vector mode for grasping the true aspect of a target, and the Relative vector mode for grasping a target's closest point of approach (CPA).

5

## [II] Vector Length (Vector Time)

The vector length of a target is proportional to its speed, and the vector time can be switched in a range of 1 to 60 minutes.

The diagram below illustrates a vector length of a target for 6 minutes, and the tip of the vector represents the target's position expected to reach 6 minutes later.

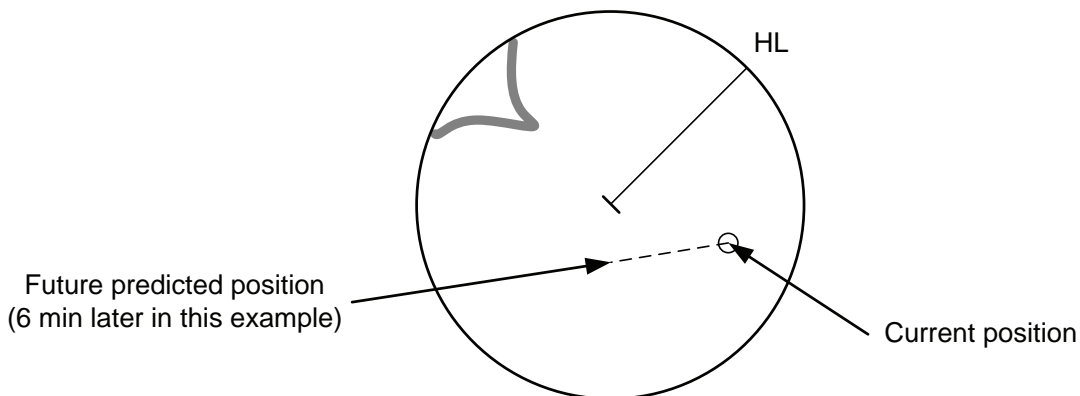

Refer to Section 5.1.7 Setting Vectors for how to change the vector time.

---

## 5.1.4 Cursor Modes (Cursor)

### Types and Functions of Cursor Modes

The types of cursor modes are listed in the table below. To use the function of a cursor mode, move the cursor onto the PPI object and press the [ENT] key.

Mode	Function
ACQ TT	Enables the target tracking function to acquire a target in manual mode.
ACT AIS	Activates AIS targets, and sets a point filter.
TGT Data	Displays the numeric data of a tracked target or AIS target.
CNCL TT	Cancel a target tracking.
DEACT AIS	Deactivates AIS target.
CNCL Data	Hides the displayed numeric data of a tracked target or AIS target.
Mark	Puts a temporary mark.
Property	Displays the information of tracked targets, AIS targets, and marks.
AUTO	Changes operation in accordance with the object at the cursor position.

### Change of Cursor Mode

#### **Procedures**

- 1 Move the cursor to the cursor mode **Cursor** (upper right of the display ① on page 2-19), and press the [ENT] key. On the PPI, press the [CLR / INFO] key and select a desired cursor mode from the list.

The selected cursor mode will be shown at the cursor mode (upper right of the display on page 2-3).

**Note:** If the function of a selected cursor mode is not used for one minute or more, the cursor mode is automatically changed to **AUTO**.



## Operation of AUTO Mode

As shown below, the **AUTO** mode performs operation in accordance with the object at the cursor position when the **[ENT]** key is pressed.

Object at Cursor Position	Operation
None	Acquires a target.
EBL	Performs EBL operation.
VRM	Performs VRM operation.
Intersection point of EBL and VRM	Performs EBL operation and VRM operation at the same time.
Parallel index line (PI)	Operates the parallel index line.
Tracked target	Displays the numeric data of the tracked target.
Tracked target with numeric data displayed	Hides the numeric data.
Sleeping AIS target	Activates the AIS target.
Activated AIS target	Displays the AIS target information.
AIS target with numeric data displayed	Hides the AIS target information.
Automatic acquisition / activation zone	Operates the automatic acquisition / activation zone.
Sector radar alarm zone	Operates the sector radar alarm zone.
AIS filter zone	Operates the AIS filter zone.

---

## 5.1.5 Setting Collision Decision Criteria

### Attention

- **Set the optimum values of collision decision conditions, depending upon vessel type, water area, weather and oceanographic conditions. (For the relations between those conditions and alarms, refer to section 5.5 Alarm Display. )**

### Input of CPA Limit

#### **Procedures**

- 1 **Move the cursor to the CPA limit setting (TT/AIS information ③ on page 2-23), and press the [ENT] key.**

The CPA Limit value input screen will appear.

- 2 **Enter the value to be set as a CPA limit.**

For inputs to the value input screen, refer to Section 3.3.4.

### Input of TCPA Limit

#### **Procedures**

- 1 **Move the cursor to the TCPA limit setting (TT/AIS information ④ on page 2-23), and press the [ENT] key.**

The TCPA Limit value input screen will appear.

- 2 **Enter the value to be set as a TCPA limit.**

For inputs to the value input screen, refer to Section 3.3.4.

## 5.1.6 Setting CPA Ring

While the distance of the specified CPA Limit value is used as the radius, the CPA ring is displayed with a red circle.

#### **Procedures**

- 1 **Move the cursor to the CPA ring display On / Off (lower right of the display ⑦ on page 2-21), and press the [ENT] key.**

The CPA ring will be displayed.

**Note:** The CPA ring is not displayed when the true vector mode is selected.



## 5.1.7 Setting Vectors (Vector Time)

Vector time can be set in minutes in the range 1 to 60 min.  
A true vector mode or relative vector mode can be selected.

### Setting vector time on the display

#### Procedures

- 1 Move the cursor to the target vector time setting (TT / AIS information ② on page 2-23), and press the [ENT] key.

The Vector Time value input screen will appear.

- 2 Enter the value to be set as vector time.

For how to input numeric data on the numeric value input screen, see Section 3.3.4.

### Setting vector time using the multi-dial [MULTI]

#### Procedures

- 1 Press the [MULTI] dial several times to activate the **Vector** mode.

**Vector** will be displayed in the multi-dial mode (lower left of the display on page 2-3).

- 2 Turn the [MULTI] dial to set the vector time.

### Setting vector mode [VECT R / T]

#### Procedures

- 1 Press the [VECT R / T] key.

The current vector mode **T** (true vector) or **R** (relative vector) will be displayed in the target vector display true / relative switching (TT / AIS information ① on page 2-23).

---

## 5.1.8 Setting the GPS antenna location

Set the GPS antenna location. Set offset ranges in longitudinal direction and latitudinal direction from the own ship's reference position.

For the setting procedure, refer to Section 7.1.9 Setting of CCRP/Antenna/GPS Antenna Position.

### Attention

- **If offset ranges are not set correctly, AIS symbols and radar echoes may be displayed shifted.**
- **When offset ranges are set, latitude and longitude data received from the GPS is offset, and the offset data is displayed as the latitude and longitude of own ship's position.**

# 5.2 TARGET TRACKING OPERATION

This section explains how to use the target tracking function.

The target tracking function automatically tracks a target, and displays the target's course and speed as vectors.

The target tracking function calculates CPA and TCPA, and issues an alarm as needed.

The tracking data is erased from memory when the power is turned off or during transmission standby.

## 5.2.1 Acquiring Target [ACQ]

Target acquisition can be performed on two modes, Automatic and Manual, and both modes can be used at the same time.

### Automatic acquisition

**Note:** If the number of targets being tracked has reached the allowable maximum and other targets (not being tracked) go into the acquisition/activation zone, automatically acquired targets are canceled in ascending order of danger.

The position of the scanner shall be at the centre of the azimuth or range in the acquisition/activation zone.

### Turning On / Off the automatic acquisition and AIS activation (AZ Menu)

#### **Procedures**

- 1 Press the [AZ] key for two seconds.

The AZ Menu will appear.

- 2 Press the [1] or [2] key.

The acquisition / activation zone 1 (AZ1) or acquisition / activation zone 2 (AZ2) will be set to on or off.

**On** :The acquisition / activation zone is turned on.  
The mark "  " and target ID number are put to an acquired target and move with the target. The vectors are displayed within 1 minute.  
AIS targets are activated.

**Off** :The acquisition/activation zone is turned off.  
The acquisition/activation zone will disappear from the radar display, but the system continues to track the acquired target.  
The activated AIS targets remain activate.

---

## Creating the automatic acquisition and AIS activation Zone

### **Procedures**

- 1 Press the [AZ] key for 2 seconds.

The AZ Menu will appear.

- 2 Open the Make AZ menu by performing the following menu operation.

3. Make AZ

- 3 Press [1] or [2] key.

The range setting of the acquisition / activation zone 1 (AZ1) or acquisition / activation zone 2 (AZ2) will be started.

- 4 Set the starting azimuth and range by turning the [EBL] dial and [VRM] dial, and press the [ENT] key.

- 5 Set the ending azimuth and range by turning the [EBL] dial and [VRM] dial, and press the [ENT] key.

The acquisition / activation zone will be determined.

## Setting the [AZ] key allocation (Set AZ Key)

A generally used acquisition / activation zone can be turned on / off by simply pressing the [AZ] key.

### **Procedures**

- 1 Press the [AZ] key for 2 seconds.

The AZ Menu will appear.

- 2 Open the AZ menu by performing the following menu operation.

5. Set AZ Key

→ 1. AZ

- 3 Set the assignment of the key.

On

:Pressing the [AZ] key turns on / off the acquisition / activation zone.

Off

:Pressing the [AZ] key does not turn on the acquisition / activation zone.

**Note:** If the RADAR Alarm key assignment is set, pressing the [AZ] key turns on / off the AZ Alarm key at the same time the RADAR Alarm is turned on / off.

## Manual Acquisition [ACQ]

**Note:** If more targets are acquired manually in the condition that the maximum number of targets are under tracking, the targets cannot be acquired.

### **Procedures**

- 1 Move the cursor onto the target to be acquired, and press the [ACQ] key.

The target will be acquired and the initial acquisition symbol will be displayed.  
The vector will be displayed within one minute.

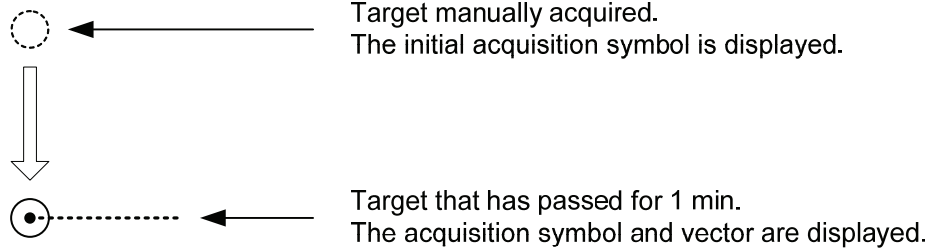

To perform operation only in the manual acquisition mode without automatic acquisition/activation, turn off the automatic acquisition/activation function.

**5**

## Use of Automatic and Manual Acquisition Modes

Use the manual acquisition mode while the automatic acquisition mode is on.

Manually acquire the target to which particular attention should be paid, and get the other targets automatically acquired. If a new target appears exceeding the maximum number of targets, the manually acquired target is displayed even in the background until it gets out of the display. However, automatically acquired targets are canceled starting far distance from own ship.

---

## 5.2.2 Canceling Unwanted Tracked Targets [TGT CNCL]

Unwanted tracked targets can be canceled one by one in the following cases:

- Tracking is no longer necessary for targets with which vectors/symbols are displayed after being acquired and tracked.
- The number of vectors on the radar display needs to be reduced for easy observation.  
When targets are to be re-acquired from the beginning, all the current vectors can also be canceled.

### Canceling targets one by one [TGT CNCL]

#### **Procedures**

- 1 **Put the cursor on the tracked target to the desired for canceling target, and press the [TGT CNCL] key.**

The vectors and symbols of the tracked targets will disappear, and only the radar video remain.

### Canceling all targets collectively [TGT CNCL]

#### **Procedures**

- 1 **Press the [TGT CNCL] key for 5 seconds.**

The vectors and symbols of all the targets will disappear, and only the radar videos remain.

**Note:** When all the targets have been canceled, the system stops tracking them. Thus, you need to re-acquire targets in manual or automatic acquisition mode. Do not cancel all the targets unless otherwise required.



### 5.2.3 Tracked Target Data Display [TGT DATA]

#### Attention

- **When a target or own ship changes its course, or when a new target is acquired, its vector may not reach a given level of accuracy until 3 minutes or more has passed after such course change or target acquisition. Even if 3 minutes or more has passed, the vector may include an error depending upon the tracking conditions.**

#### Type of Data Display (Target Information)

##### Target Data

Target identification (TT ID)	ID number of the target
True bearing (BRG)	0.1° unit
Range	0.01 NM unit
Course	0.1° unit
Speed	0.1 knot unit
Closest point of approach (CPA)	0.01 NM unit
Time to CPA (TCPA)	0.1 min unit
Bow crossing range (BCR)	0.01 NM unit
Bow crossing time (BCT)	0.1 min unit

The target for which its numeric data is displayed is marked with a symbol "  " to distinguish from other targets.

If a target's data is displayed, but without the symbol "  ", such a target exists outside the currently displayed radar display.

#### Method of Displaying Numeric Data [TGT DATA]

##### Procedures

- 1 **Put the cursor on the tracked target for which numeric data is to be displayed, and press the [TGT DATA] key.**

Then, the data of the designated target will appear, it will be marked with a symbol

"  ". The target data will remain on the radar display until the target is lost and its vector disappears, or until another target is designated.

If a target with the mark "  " is designated, only its true bearing and range will appear until its vector appears.

---

## **Cancellation of Numeric Data Display (CNCL Data)**

### **Procedures**

- 1 Put the cursor on the tracked target with which numeric data is displayed, and press the [CLR / INFO] key.

The cursor mode list will appear.

- 2 Press the [6] key.

The numeric value will disappear.

## **5.2.4 Displaying Target ID No. (Target Number Display)**

A target ID number is a value displayed beside the acquisition symbol when a target is acquired.

A target ID number 1 to 100 is assigned to each target in acquisition order. Once a target ID number is assigned, it identifies the target until the target is lost or the target acquisition is canceled.

### **Procedures**

- 1 Press the [TT MENU] key.

- 2 Press the [4] key.

Target Number Display will appear.

- 3 Press the [numeric] key corresponding to the display method to be set.

On	:Displays target ID numbers.
Off	:Hides target ID numbers.
Target Track	:Displays target ID number with target track.

If there are many tracking targets and their symbol display is confusing, set Target Number Display to off to view the radar display easily.

**Note:** An ID number is always displayed for only targets with which numeric data is displayed.

## 5.2.5 Adding Tracked Target ID Name (Name)

The system can enter a name for each of tracking targets that have been acquired.

### Procedures

- 1 Put the cursor on the tracked target, and press the [CLR / INFO] key.

The cursor mode list will appear.

- 2 Press the [8] key.

The TT Target Information will appear.

- 3 Press the [1] key.

The setting items for ship name (Name) will be displayed.

- 4 Select the input method.

:Selection of one of previously input ship names.

When this method is selected, a list of ship names that have been input by selecting  will be displayed.

:Input of a new ship name.

When this method is selected, the ship name (Name) input window will open.

5

### Entering a new ship name (Input)

- 5 Input a new ship name.

Up to 8 characters can be input as a ship name.

For the input method on the character input screen, see Section 3.3.4.

The input name by selecting  is saved in .

### Selecting one of previously input ship names (Data Base)

- 5 Press the [numeric] key corresponding to the ship name to be selected.

The selected ship name will be entered.

\*  can contain 30 ship names.

---

## 5.2.6 Reference Target (Reference)

The system can display the own ship's speed. To do so, it sets a reference target by tracking a target for which ground fixed.

### Attention

- The reference target function is to be used if the own ship's speed cannot be displayed normally due to trouble such as a speed sensor malfunction. Do not use the reference target function except in emergencies.
- If the speed or course of the own ship is changed or a new reference target is set, the displayed speed may take 3 minutes or more to reach the specified speed after the speed / course change or the setting.  
Even after 3 minutes or more has passed, the speed may differ from the specified speed depending on the tracking condition.
- If a large radar echo such as a land target is set as a reference target, the vectors of the speed and other tracking targets will not be displayed correctly and may cause an accident.
- If a sailing ship is set as a reference target, the vectors of the speed and other tracking targets will not be displayed correctly and may cause an accident.
- If the **REF.** is selected for the speed sensor, the AIS function cannot be turned on.
- If the reference target is lost or the target tracking function is stopped, the speed sensor is placed in manual mode **MAN**.
- The loss of a reference target may have a major impact on the accuracy of the results for true speed and true course of the target and that own speed will be degraded.
- The reference targets are only used for the calculation of true speed.

**Procedures****1 Tracking a target for which ground fixed.****2 Put the cursor on the tracked target, and press the [CLR / INFO] key.**

The cursor mode list will appear.

**3 Press the [8] key.**

The Property will appear.

**4 Press the [3] key.**

The reference target function will be set to on or off.

On :A reference target is set.

Off :The reference target is canceled.

**5 Put the cursor on the speed sensor switching (Own ship information ② on page 2-22), press the [ENT] key, and select  REF.**

The speed of own ship calculated from the reference target will be displayed.

When a reference target is set, the symbol display is changed to "  $\bigcirc_R$  ".

Only one target can be set as a reference target.

When a new reference target is set, the previously set reference target is canceled.

**Note:** If AIS function is set to on, the reference target function cannot be used.

---

## 5.2.7 Operation Test (TT Test Menu)



# CAUTION



**This function is provided to test if the target tracking function is operating normally. Thus, do not use the function except when you test the target tracking function.**

**In particular, if the operation test mode is used during navigation, pseudo targets appear on the radar display and they are confused with actual targets.**

**Do not use the mode during navigation.**

**Otherwise, an accident may result.**

The following functions are available for testing the target tracking function:

[I] Test Video	Makes an operation check on the target detection circuit.
[II] TT Simulator	Generates pseudo targets on the radar display in order to test if the target tracking function is operating normally.
[III] Status	Displays the status of the target tracking function.
[IV] Gate Display	Displays the gate size for acquiring / tracking a target.

## **[I] Test Video**

Test Video is used to check whether the video signals under target acquisition and tracking are inputted to and processed in the target detection circuit normally.

However, it is sufficient to check that VDH in Test Video is displayed.

**Note:** Test Video may not be displayed for a target which is not yet acquired or tracked. Test Video may not be displayed either if the [GAIN] dial or [SEA] dial is not properly adjusted.

### **Procedures**

- 1 Press the [TT MENU] key.**
- 2 Open the TT Test Menu by performing the following menu operation.**

#### **9. TT Test Menu**

- 3 Press the [1] key.**

The setting items for Test Video will be displayed.

- 4 Select the test video to be displayed.**

In general, **VDH** is sufficient for target display checks in test video mode.

If any target displayed clearly in the radar display is not displayed in the Test Video mode, the target detection circuit of the Target Tracking unit may have a trouble

### **Cancellation**

- 1 Press the [1] key while the TT Test Menu is displayed.**

The setting items for Test Video will be displayed.

- 2 Press the [1] key**

The test video display will be turned off.

### **III Target Tracking Simulator**

Pseudo targets can be generated in certain known positions to check whether the target tracking units are operating normally. Since the pseudo targets move depending on known parameters, the values for these pseudo targets can be compared with the known value if the pseudo targets are acquired and tracked, and displayed. Thus, it can be checked if the system is operating normally.

#### **Procedures**

- 1 Press the [STBY] key.**

The equipment will enter the transmission standby state.

- 2 Press the [TT MENU] key.**

- 3 Open the TT Test Menu by performing the following menu operation.**

#### **9. TT Test Menu**

- 4 Press the [2] key.**

The setting items for TT Simulator will be displayed.

- 5 Select the scenario to be set.**

- 6 Press the [TX / PRF] key.**

The simulator will be activated and generate pseudo targets. The characters "X" at the bottom of the radar display blinks indicating that the simulation mode is active.

Target tracking simulator / scenario

Scenario	Target start point		Target end point		Pseudo-target speed
	Distance	Bearing	Distance	Bearing	
1	3.2nm	20°	1nm	90°	20kn
2	6nm	0°	0nm	0°	10kn
3	6nm	every 18°	1nm	every 18°	10kn
4	6nm	45°	1nm	45°	105kn
5	6nm	45°	6nm	150°	20kn
6	6nm	45°	6nm	150°	20kn

**Note:** When the simulator is operating, set 0° as the heading bearing, and 0 kn as the speed of own ship. When the range between own ship and the pseudo target is 0, the target will disappear.

#### **Cancellation**

- 1 Press the [STBY] key.**

The equipment will enter the transmission standby state.

- 2 Press the [2] key while the TT Test Menu is displayed.**

The setting items for TT Simulator will be displayed.

- 3 Press the [1] key.**

The TT Simulator display will be turned off.



**[III] Status display (Status)**

The current Target Tracking status will appear.

**Procedures**

- 1 Press the [TT MENU] key.
- 2 Open the TT Test Menu by performing the following menu operation.

9. TT Test Menu

- 3 Press the [3] key.

The setting items for Status will be displayed.

*Constant	: Vector response
*VID Level TD	: Threshold value used for automatic acquisition
*VID Level High	: Threshold value used for tracking
*VID Level Low	: Unused
*Gate Size	: Size of gate used for tracking
*Tracking	: Number of targets currently acquired

---

## [IV] Gate Display

The gate displays an area monitoring a target using the Target Tracking function. This radar equipment allows the gate size to change automatically according to target range and size. User can check the gate size using the following function.

### Procedures

- 1 Press the [TT MENU] key.
- 2 Open the TT Test Menu by performing the following menu operation.

9. TT Test Menu

- 3 Press the [4] key.

The gate display mode is switched.

On	:Gate is displayed
Off	:Gate is not displayed

- 4 Display the numeric value of a target according to Section 5.2.3.

The numeric value of the target will be displayed, and the tracked target symbol will be enclosed in a green gate.

**Note:** The Target Tracking can display the gate of two targets simultaneously.

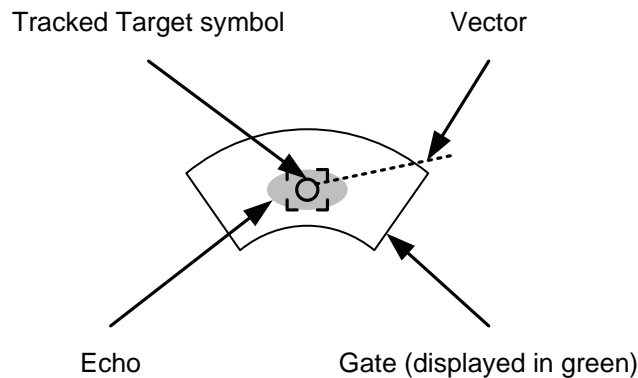

# 5.3 AIS OPERATION

## 5.3.1 Restrictions

The following restrictions are placed on use of the AIS function.

- The AIS function is unavailable in the following cases:  
     **MAN** or  **REF.** is selected for the speed sensor.  
    The current offset (Set/Drift Setting) is set while  **LOG** or  **2AXW** is selected for the speed sensor.
- **LOG** or  **2AXW** cannot be selected for the speed sensor in the following case:  
    The AIS function is turned on and the current offset (Set/Drift Setting) is selected.
- **MAN** cannot be selected for the speed sensor in the following case:  
    The AIS function is On.
- Current offset (Set/Drift Setting) cannot be turned On in the following case:  
     **LOG** or  **2AXW** is selected for the speed sensor while the AIS function is on.

**5**

## 5.3.2 Setting AIS Display Function (AIS Function)

### Attention

- When the AIS function is set to Off, the AIS display function is turned off and AIS symbols are no longer displayed.
- Once the AIS display function is set to Off, it is not automatically switched to On even if a dangerous target exists.

### Procedures

- 1 Put the cursor on the AIS On / Off (TT / AIS information  on page 2-23), and press the [ENT] key.

The received AIS information will be shown on the radar display.

---

### 5.3.3 Activate AIS Targets (Activate AIS)

Activate an AIS target, and display the target's vector and make a collision decision.

#### **Manual activation (ACT AIS)**

Activate an AIS target in manual mode to display the vector and heading line.

##### **Procedures**

- 1 **Put the cursor on the AIS symbol to be activated, and press the [CLR/INFO] key.**

The setting items for cursor modes will be displayed.

- 2 **Press the [2] key.**

The selected AIS target will be activated.

#### **Automatic activation (AUTO Activate)**

Activate an AIS target in automatic mode to display the vector and heading line.

When the automatic activation function is used, AIS targets are automatically activated when they go into the automatic activation zone. The automatic activation zone is identical to the automatic acquisition zone (AZ) used for target tracking. For the zone setting, refer to "Acquiring Target" in Section 5.2.1

The position of the scanner shall be at the centre of the azimuth or range in the acquisition/activation zone. If there are more AIS targets than the allowable maximum, they are deactivated in the low-priority (See the section 5.1.2).

**Reference** If an AIS target is activated but the vector is not displayed, refer to "Displaying Target ID Number" in section 5.3.6

### 5.3.4 Deactivate AIS Targets (Deactivate AIS)

Deactivate an AIS target and clear the display of the vector and heading line.

##### **Procedures**

- 1 **Put the cursor on the AIS target to be deactivated, and press the [CLR/INFO] key.**

The setting items for cursor modes will be displayed.

- 2 **Press the [5] key.**

The selected AIS target will be deactivated.

**Note:** This operation is available only for an activated AIS target.

## 5.3.5 Displaying AIS Information [TGT DATA]

### Types of information displayed

There are two modes (simple and detail) to display AIS target information. The display items are determined by the selected mode.

Display Item	Detail mode	Simple mode
NAME (ship name)	Up to 20 characters	
Call Sign	Up to 7 characters	
MMSI	Up to 9 characters	
COG (course over ground) or CTW (course through water)	0.1° unit	
SOG (speed over ground) or STW (speed through water)	0.1 knot unit	
CPA (closest point of approach)	0.01 nm unit	
TCPA (time to CPA)	0.1 min unit	
BRG (true bearing)	0.1° unit	Not displayed
Range	0.01 nm unit	
HDG (heading bearing)	0.1° unit	
ROT (rate of turn)	0.01°/min	
POSN (latitude / longitude)	0.001' unit	
Destination (waypoint)	Up to 20 characters	
NAV Status	Status (number)	

If the numeric information of ROT is blank, the radar is receiving the AIS data which is cannot displayed. In this case, you can only trust the turning direction which is indicated by the turn indicator. The turn indicator is displayed on the AIS symbol as the line perpendicular to the heading direction. (See the Section 5.1.2 "Types and Definitions of AIS Target Symbols")

The detail mode displays the numeric data of only a single ship, the simple mode can display the numeric data of up to two ships.

For NAV Status, one of the following statuses is displayed in accordance with Navigation Status:

No.	Status
0	Under Way Using Engine
1	at Anchor
2	Not Under Command
3	Restricted Maneuverability
4	Constrained by Her Draft
5	Moored
6	Aground
7	Engaged in Fishing
8	Under Way Sailing
9	Reserved
10	Reserved
11-14	Reserved
15	Not Defined

---

## Displaying AIS Target Information [TGT DATA]

### **Procedures**

- 1 Put the cursor on the AIS target of which information is to be displayed , and press the [TGT DATA] key.

The information of the selected AIS target will be displayed.

**Reference:** When the numeric data of a target is displayed but the mark " [ ] " is not on the radar display, the target is outside the display.

## Canceling AIS Target Information Display (CNCL Data)

### **Procedures**

- 1 Put the cursor on the activated AIS target of which information display is to be cancelled, and press the [CLR / INFO] key.

The setting items for cursor modes will be displayed.

- 2 Press the [6] key.

The information display of the selected AIS target will be cleared.

## Selecting Detail / Simple Mode for AIS Target Information Display

### **Procedures**

- 1 Put the cursor on the detail/simple display switching (AIS target information ① on page 2-25), and press the [ENT] key.

The detail or simple mode display for AIS target information will be selected.

## Message

Received AIS messages can be displayed.

Up to 10 messages of addressed message and up to 10 messages of broadcast message can be displayed.

If the number of messages exceeds 10, the oldest received messages are sequentially deleted.

## Displaying Message Selected from List (Message)

### **Procedures**

- 1 Press the [RADAR MENU] key twice.
- 2 Open the Message menu by performing the following menu operation.

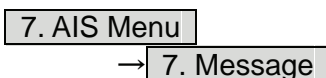

- 3 Press the [1] or [2] key.

Pressing [1] key lists addressed messages; pressing [2] key lists broadcast messages.

Each list shows ship names and message-received time.

For an unread message, [\*] is displayed to the left of the item number.

- 4 Press the [numeric] key corresponding to the message to be displayed.

The message will appear.

## Displaying Specified Target's Message

### **Procedures**

#### **1 Display AIS target information.**

If there are messages from the target, a message mark will be displayed in the unread message display field ( AIS target information ② on page 2-25).

#### **2 Put the cursor on the unread message display (AIS target information in ② on page 2-25), and press the [ENT] key.**

The message will appear.

## Deleting Message (Delete)

### **Procedures**

#### **1 Press the [1] key while the message is displayed.**

The Confirmation Window will appear.

#### **2 Press the [1] key.**

The message will be deleted, and the ship name and message-received time will disappear from the list.

**5**

## Displaying Data of Lost AIS Target (Display Lost TGT Data)

The data of the last-lost AIS target can be displayed.

The data of only one target that has been lost most recently can be displayed.

### **Procedures**

#### **1 Press the [RADAR MENU] key twice.**

#### **2 Open the Display Lost Target Data menu by performing the following menu operation.**

7. AIS Menu

→ 8. Display Lost TGT Data

The data of the last-lost AIS target will be displayed.

## Displaying Own Ship's AIS Data (Own Ship's AIS Data)

The AIS data of own ship can be displayed.

### **Procedures**

#### **1 Press the [RADAR MENU] key twice.**

#### **2 Open the Own Ship's AIS Data menu by performing the following menu operation.**

7. AIS Menu

→ 9. Own Ship's AIS Data

The own ship's AIS data will be displayed.

---

## 5.3.6 Displaying Target ID No. (Target Number Display)

When an AIS target is activated, a target ID number is displayed next to the AIS target symbol. A target ID number 1 to 100 is assigned to each target in activation order. Once a target ID number is assigned, it identifies the target until the target is lost or deactivated.

### Procedures

- 1 Press the [RADAR MENU] key twice.
- 2 Open the Target Number Display menu by performing the following menu operation.



- 3 Press the [numeric] key corresponding to the display method to be set.

On	:Displays target ID numbers.
Off	:Hides target ID numbers.
Target Track	:Displays target ID number with AIS track.
Ship's Name	:Displays the ship's name.

If there are many tracking targets and their symbol display is confusing, set Target Number Display to off to view the radar display easily.

**Note:** An ID number or ship's name is always displayed for only targets with which numeric value is displayed.

## 5.3.7 Setting AIS Filter (AIS Filter Setting)

### About an AIS filter

By setting an AIS filter, an AIS target in the area can be displayed by priority or only the targets in the area can be displayed. An AIS filter is initially set in a circle having a radius of 20 [nm] from the CCRP. If 301 or more AIS targets exist in the filter range, they are displayed in the priority order explained in Section 5.1.2 Symbols - Types and Definitions of AIS Target Symbols.

### Types of AIS Filters (Filter Type)

There are the following 3 types of AIS filters:

Range	:A filter is set in a circle with a set range as the radius.
Sector	:A filter is set in a sector formed by two bearings with the bow as reference.
Zone	:A filter is set in a zone formed by two bearings and two ranges with the bow as reference.

### Procedures

- 1 Put the cursor on the AIS filter mode switching (TT / AIS information ⑫ on page 2-23), and press the [ENT] key to select the filter to be set.

The AIS filter will be selected.



## Creation of AIS Filter (Make AIS Filter)

### **Procedures**

- 1 Press the [RADAR MENU] key twice.
- 2 Open the AIS Filter Setting menu by performing the following menu operation.



- 3 Press the [2] key.

The mode to make an AIS filter will be activated.

### [I] Setting Range Filter

- 4 Set a filter range by turning the [VRM] dial, and press the [ENT] key.

### [II] Setting Sector Filter

- 4 Set a starting bearing by turning the [EBL] dial, and press the [ENT] key.
- 5 Set an ending bearing by turning the [EBL] dial, and press the [ENT] key.

### [III] Setting Zone Filter

- 4 Set a starting bearing and range by turning the [EBL] dial and [VRM] dial, and press the [ENT] key.
- 5 Set an ending bearing and range by turning the [EBL] dial and [VRM] dial, and press the [ENT] key.

**Note:** When the automatic activation function is enabled, the filter range is automatically changed for covering the automatic activation zone. Thus, the automatic activation zone is always within the filter range.

## AIS Filter Display On/Off (Filter Display)

### **Procedures**

- 1 Press the [RADAR MENU] key twice.
- 2 Open the AIS Filter Setting menu by performing the following menu operation.

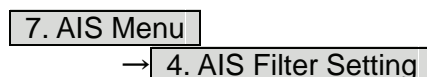

- 3 Press the [3] key.

Filter Display will be set to on or off.

---

## Display of Targets outside AIS Filter (Filter Mode)

### **Procedures**

- 1 Press the [RADAR MENU] key twice.
- 2 Open the Filter Mode menu by performing the following menu operation.

7. AIS Menu

→ 4. AIS Filter Setting

- 3 Press the [6] key.

The Filter Mode is switched.

Display

:Displays only AIS targets in the AIS filter.

Priority

:Displays AIS targets in the AIS filter by priority, and also displays targets outside the AIS filter.

**Note:** Activated AIS targets can be displayed even when they are outside the AIS filter.

## Point Filter

AIS targets which are not displayed because they are outside the AIS filter or at low priority levels can be activated by giving a higher priority to them.

### **Procedures**

- 1 Put the cursor on the position where a point filter is to be set, and press the [CLR / INFO] key to select the filter to be set.

The setting items for cursor modes will be displayed.

- 2 Press the [2] key.

A point filter will be set at the cursor position.

If an AIS target is in the point filter, it will be activated.

When an AIS target is activated or an AIS target is not found within one minute, the point filter will be cleared.

**Note:** The point filter's range is 1 nm, and cannot be changed.

## 5.3.8 Conditions for Deciding AIS Target to be Lost

### About a lost target

When the data of an AIS target cannot be received for a specified time, the target is decided to be lost and the target data is deleted. As shown in the table below, the time until target data is deleted varies depending on the class of receive data and the target status.

#### Deciding AIS Target to be Lost

Target status	Time until data deletion	
	SOLAS ship (Class A)	SOLAS ship (Class B)
Vessel below 3 knots (Class A) or 2 knots (Class B) and it is now at anchor or on the berth	<b>18 min</b>	<b>18 min</b>
Vessel of 3 knots or more and it is now at anchor or on the berth	<b>60 sec</b>	<b>18 min</b>
Vessel of 0 to 14 knots (Class B: 0 to 14 knots)	<b>60 sec</b>	<b>180 sec</b>
Vessel of 0 to 14 knots and it is now changing the course	<b>60 sec</b>	<b>180 sec</b>
Vessel of 14 to 23 knots	<b>36 sec</b>	<b>180 sec</b>
Vessel of 14 to 23 knots and it is now changing the course	<b>36 sec</b>	<b>180 sec</b>
Vessel of 23 knots or more	<b>30 sec</b>	<b>180 sec</b>
Vessel of 23 knots or more and it is now changing the course	<b>30 sec</b>	<b>180 sec</b>

**Reference:** When a dangerous target ship is lost, a lost alarm is issued and the symbol changes to a lost symbol. The system calculates the current position from the last-received data and continues displaying the symbol for eternity.  
If the [ALARM ACK] key is pressed, the symbol is cleared.

---

## 5.3.9 Setting Conditions for AIS Alarm (AIS Alarm Setting)

Conditions for issuing a Lost alarm and CPA/TCPA alarm for AIS targets can be set.

### Setting of Condition for Lost Alarm

#### Procedures

- 1 Press the [RADAR MENU] key twice.
- 2 Open the AIS Alarm Setting menu by performing the following menu operation.



- 3 Press the [1] key.  
The setting items for Lost Alarm will be displayed.
- 4 Press the [numeric] key corresponding to the condition to be set.

Off	:A lost alarm is not issued.
Danger	:A lost alarm is issued only for AIS targets for which a dangerous target alarm has been issued.
ACT&Danger	:A lost alarm is issued only for activated AIS targets and AIS targets for which a dangerous target alarm has been issued.

**Note:** A lost alarm is not issued for sleeping AIS targets.

### Setting of Condition for CPA/TCPA Alarm

#### Procedures

- 1 Press the [RADAR MENU] key twice.
- 2 Open the AIS Alarm Setting menu by performing the following menu operation.



- 3 Press the [2] key.  
The setting items for CPA/TCPA Alarm is switched.
- |           |   |
|-----------|---|
| ACT       | :A CPA/TCPA alarm is issued only for activated AIS targets.           |
| ACT&Sleep | :A CPA/TCPA alarm is issued for all AIS targets on the radar display. |

# 5.4 DECISION OF TARGETS AS IDENTICAL (ASSOCIATION)

## Setting of Function to Decide Targets as Identical (Association)

When an AIS target and a tracking target are decided to be identical, an association symbol is displayed for the targets regarded as identical. In this case, the AIS target symbol is automatically activated.

### Attention

- Turn off **Association** in order not to make a decision on if targets are identical, or in order to display symbols that have disappeared.

5

#### Procedures

- 1 Put the cursor on the association On/Off (TT/AIS information ⑪ on page 2-23), and press the [ENT] key.

Association will be set to on or off.

## Setting of Conditions for Deciding AIS and Tracked Targets as Identical (Association Setting)

#### Procedures

- 1 Press the [TT MENU] key.
- 2 Press the [1] key.

The Association Setting menu will appear.

- 3 Select and enter the item to be set.

Conditions for deciding targets as identical will be set. When the differences of all item between AIS and tracked target are under the set conditions..  
Once regard as identical, when one of the differences exceed 125% of the set condition, they are regarded as dissidence.

\* The setting for this function is common to Association Setting in the AIS Menu.

---

## Types of Decision Conditions to be Set

Decision conditions

1. Association	On / Off (Function to decide targets as identical)
2. Priority	AIS / TT (Symbol to be displayed)
3. Bearing	0.0 to 9.9°
4. Range	0 to 999 m
5. Course	0 to 99°
6. Speed	0 to 99 kn
7. Applicable AIS Target	ACT or ACT&Sleep (activated AIS target or all AIS target)



## CAUTION



**If a great value is set as a condition for deciding targets as identical, a tracking target near an AIS target is regarded as identical to the AIS target and it may not be displayed any more.**

**For example, when a pilot boat (which is a small target not being tracked) equipped with an AIS function approaches a cargo ship as a tracking target not equipped with an AIS function, the tracking target symbol of the cargo ship may not be displayed any more.**

# 5.5 ALARM DISPLAY

Critical alarm messages for Target Tracking (TT) and AIS functions:

Error message	Description
CPA/TCPA	There is a dangerous target.

Alarm messages for Target Tracking (TT) and AIS functions:

Error message	Description
CPA/TCPA	There is a dangerous target.
New Target	A new target is acquired in the automatic acquisition zone
Lost	There is a lost target.
REF Target	The accuracy of the reference target may be decreased.
95% Capacity	The number of targets being tracked by the Target Tracking function has reached 95% of the maximum.
MAX Target	The number of targets being tracked by the Target Tracking function has reached the maximum.
AIS 95% Capacity	The number of displayed AIS target symbols has reached 95% of the maximum.
AIS MAX Target	The number of received data items exceeds the maximum number of AIS target symbols that can be displayed.
AIS ACT 95% Capacity	The number of activated AIS targets by the AIS function has reached 95% of the maximum.
AIS ACT MAX	The number of activated AIS targets by the AIS function has reached the maximum.
AIS Alarm ***	Alarm information issued with the ALR sentence by the AIS. *** is a 3-digit number which is Local Alarm No in the ALR sentence.
AIS Alarm 001	Tx malfunction
AIS Alarm 002	Antenna VSWR exceeds limit
AIS Alarm 003	Rx channel 1 malfunction
AIS Alarm 004	Rx channel 2 malfunction
AIS Alarm 005	Rx channel 70 malfunction
AIS Alarm 006	general failure
AIS Alarm 008	MKD connection lost
AIS Alarm 025	external EPFS lost
AIS Alarm 026	no sensor position in use
AIS Alarm 029	no valid SOG information
AIS Alarm 030	no valid COG information
AIS Alarm 032	Heading lost/invalid
AIS Alarm 035	no valid ROT information

An alarm is displayed in the alarm indication (Alarm on page 2-9)



See also section 9.1.1 "List of Alarm Indications".

**CPA / TCPA Alarm**



# CAUTION







**Since these alarms may include some errors depending on the target tracking conditions, the navigation officer himself should make the final decision for ship operations such as collision avoidance.**

**Making the final navigation decision based only on the alarm may cause accidents such as collisions.**

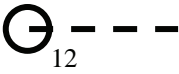
In the system, targets are categorized into two types: tracked / activate AIS targets and dangerous targets. The grade of danger can easily be recognized on the display at a glance. So the officer can easily decide which target he should pay attention to. It is not possible to switch off the tracked target visual alarm, unless tracking is ceased, or the alarm condition no longer applies. The types of target and alarm are shown below.

**CPA / TCPA Alarm**

Status	Symbol on display	Alarm characters	Alarm sound	Conditions
Tracked target  Activated AIS target	  	(Off)	(Off)	<ul style="list-style-type: none"> <li>• CPA &gt; CPA LIMIT</li> <li>• 0 &gt; TCPA</li> <li>• TCPA &gt; TCPA LIMIT</li> </ul> <p>The symbol is displayed when one of the above conditions is met.</p>
Dangerous target	    Red blinking	CPA / TCPA	Beep sound (pee-poh) Alarm acknowledgeable	<ul style="list-style-type: none"> <li>• CPA ≤ CPA LIMIT,</li> <li>• 0 ≤ TCPA ≤ TCPA LIMIT</li> </ul> <p>An alarm is issued when all the conditions are met. The AIS targets that issues alarm refer to 5.3.9.</p>

CPA Limit and TCPA Limit: The Setting Values



**Alarm for New Target Acquired in Automatic Acquisition Zone (New Target)**



# CAUTION



**In setting an automatic acquisition zone, it is necessary to adjust the gain, sea clutter suppression and rain / snow clutter suppression to ensure that target echoes are displayed in the optimum conditions. No automatic acquisition zone alarms will be issued for targets undetected**

The automatic acquisition function sets a zone in a range and issues an alarm when a new target (which is not yet acquired) goes into this zone.  
 For the setting of an automatic acquisition zone, refer to "Acquiring Target" in Section 5.2.1.

**Alarm for New Target Acquired in Automatic Acquisition Zone**

Status	Symbol on display	Alarm characters	Alarm sound	Conditions
New target in automatic acquisition zone	 Red Blinking	New Target	Beep sound (pipi-pipi) Alarm acknowledgeable	The alarm is issued when a new target is acquired in the automatic acquisition zone.

**Note:** When an already acquired target goes into automatic acquisition zone, the alarm message is not displayed and the buzzer does not sound either.

## Lost Target Alarm

### Attention

- **If the gain, sea clutter suppression, rain/snow clutter suppression are not adjusted adequately, the lost target alarm may be easily generated. So such adjustments should be mad carefully.**

When it is impossible to continue tracking any acquired and tracked target, or the data of AIS target cannot received for a specified time, the **LOST** alarm will be generated. The typical causes for alarm generation are shown below, but not limited to the following:

- The target echo is very weak.
- The target is shadowed by a shore or a large ship and its echo is not received.
- The target echo is blurred by sea clutter returns.

If a target under tracking goes out of a range of 32 nm and can no longer be tracked, it is canceled without a lost target alarm.

### Lost Target Alarm

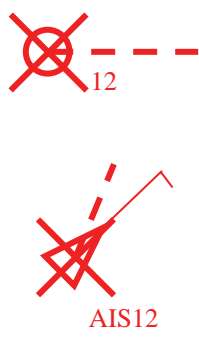
Status	Symbol on display	Alarm characters	Alarm sound	Conditions
Lost target	 Red Blinking	Lost	Beep sound (pee) Alarm acknowledgeable	The alarm will sound once when a lost target symbol is displayed.

## Gyro Set Alarm

The GYRO I/F in this system receives signals from a gyro. Even if the power is turned off, the system will follow up the gyro. However, the system stops the follow-up operation when the power of the master gyro is turned off or when any trouble occurs to the line. When the power of the master gyro is recovered, the **Set Gyro** alarm will be generated.

If this alarm occurs, set the gyro.

### Gyro Set Alarm

Alarm characters	Alarm sound	Conditions
Set Gyro	Beep sound (pipi-pipi)	The signals from the gyro are stopped, but the gyro is recovered.

# 5.6 TRACK FUNCTION

## 5.6.1 Past Position (Past POSN)

### Procedures

- 1 Put the cursor on the past position display interval unit switching (TT/AIS information ⑦ on page 2-23), and press the [ENT] key to set a desired unit.

The past position display interval unit will be set to  or .

- 2 Put the cursor on the past position display interval switching (TT/AIS information ⑥ on page 2-23), and press the [ENT] key to set a desired track display interval.

The past position will be set.

<input type="text" value="Off"/>	:Tracks are not displayed.
<input type="text" value="Numeric"/>	:Tracks are displayed at intervals of a specified value.

The past position function can display up to 10 past positions of a target under tracking. The past position display interval can be set to specified time intervals of 0.5, 1, 2, or 4 minutes, or specified range intervals of 0.1, 0.2, 0.5, or 1 nm.

The specified interval is displayed in the past position display interval switching (TT / AIS information ⑥ on page 2-23). When  is displayed, the track display function is turned off.

The track mode operates in conjunction with the vector mode, and a true or relative track is displayed.

In relative vector mode, the relative tracks of the target are displayed.

In true vector mode, true tracks that are calculated from the relative bearing, range, own ship's course, and speed are displayed.

The target is acquisition, past position of traced target is start plot.

The AIS target is displayed, past position of AIS target is start plot.

If the past position plotted time is short, the indicated past position duration may not have achieved the specified time or range.

---

## 5.6.2 Target Ship's Tracks (Target Track)

This function makes settings for the tracks of tracked targets and AIS targets.  
The system can display the tracks of up to 20 target ships.

### [I] Track Color Setting (Target Track Color)

#### **Procedures**

- 1 Put the cursor on the tracked target or activated AIS target, and press the [CLR / INFO] key.

The setting items for cursor modes will be displayed.

- 2 Press the [8] key.

The TT Target Information will appear.

- 3 Press the [2] key.

The setting items for Track Color will be displayed.

- 4 Press the [numeric] key corresponding to the track color to be set.

Colors set by performing the procedure in [\[III\] Setting of Target Ship's Track Colors](#) can be selected.

Individual colors can be set for up to 10 ships.

The same color is set for 11 to 20 ships.

### [II] Target Ship's Track Function On/Off (Target Track Function)

#### **Procedures**

- 1 Open the T.TRK menu by performing the following menu operation.

T.TRK

- 2 Press the [1] key.

The Target Track Function will be set to on or off.

On	:Target Track Function is turned on.
Off	:Target Track Function is turned off.

\* Note that when this function is turned off, all the other ship's track functions are turned off. In this case, the track data of other ships is not saved, so they cannot be traced later.

### III] Setting of Target Ship's Track Colors (Target Track Color)

You can set either one track color for all targets under tracking, or individual colors for the ships of track numbers 1 to 10. The tracks of ships 11 to 20 are displayed in the same color.

\* If the other ship's track function (Target Track Function) is turned off, the track data of other ships is not saved.

#### **Procedures**

- 1 **Open the Target Track Color menu by performing the following menu operation.**

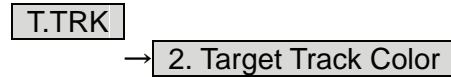

- 2 **Press the [1] key.**

The setting items for All will be displayed.

- 3 **Press the [numeric] key corresponding to the track display to be set.**

<input type="checkbox"/> Individual	:Track color is set individually for ships.
<input type="checkbox"/> Color name	:One color is set for all ships.

# 5

#### Individual setting

- 4 **Press the [numeric] key corresponding to the track number to be set.**

The setting items for the selected track number will be displayed.

- 5 **Press the [numeric] key corresponding to the track color to be set.**

The track color of the selected track number will be set.

When  Individual is selected, the track numbers  Target Track No. 1 to  No. 10 and the individual setting for  Other are valid. Select a color for each target.

The color list is displayed by pressing the [numeric] key corresponding to the item number to be set. Select a desired color. There are 8 color choices:  Off,  White,  Gray,  Blue,  Green,  Yellow,  Pink, and  Red.

<input type="checkbox"/> Target Track No. 1 to <input type="checkbox"/> No. 10	:Setting for 1 to 10 ships
<input type="checkbox"/> Other	:Setting for 11 to 20 ships

\* Note that the individual setting is not enabled unless  Individual is selected.

---

## [IV] Setting of Target Ship's Track Display (Target Track Display)

The target track display function can be turned on / off. Choices for track display are displaying / hiding the tracks of all ships and Individual (displaying the tracks of individual ships).

### **Procedures**

- 1 **Open the Target Track Display menu by performing the following menu operation.**

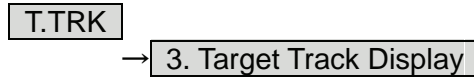

- 2 **Press the [1] key.**

The setting items for All will be displayed.

- 3 **Press the [numeric] key corresponding to the track display to be set.**

<input type="text" value="Individual"/>	:Track display is set for individual ships.
<input type="text" value="Off"/>	:The tracks of all ships are hidden.
<input type="text" value="On"/>	:The tracks of all ships are displayed.

\* Even when Target Track Display is turned off, the track data of other ships is saved if Track Memory Interval is set.

### Individual setting

- 4 **Press the [numeric] key corresponding to the track number to be set.**

The selected track number display will be set to on or off.

<input type="text" value="On"/>	:The track number display is turned on.
<input type="text" value="Off"/>	:The track number display is turned off.

When  is selected, the track numbers  to  and the individual setting for  are valid. Select on / off for each target.

<input type="text" value="Target Track No. 1"/> to <input type="text" value="No. 10"/>	:Setting for 1 to 10 ships
<input type="text" value="Other"/>	:Setting for 11 to 20 ships

\* Note that the individual setting is not enabled unless  is selected.

---

## **[V] Setting of Target Ship's Track Saving Interval (Track Memory Interval)**

An interval for saving target ship's track data can be set.

\* This function is not available when the Target Track Function is turned off.

### **Procedures**

- 1 Open the T.TRK menu by performing the following menu operation.**

**T.TRK**

- 2 Press the [4] key.**

The setting items for Track Memory Interval will be displayed.

- 3 Press the [numeric] key corresponding to the interval to be set.**

Select an interval from the following:

Off /  
3sec / 5sec / 10sec / 30sec /  
1min / 3min / 5min / 10min / 30min / 60min /  
1nm / 3nm / 5nm / 10nm

---

## **[VI] Clear of Target Ship's Track**

The target ship's track can be cleared by setting a color or a track number.

\* If Card T.TRK Display is used, target ship's tracks displayed through the card cannot be cleared.

### **Clear of Tracks by Setting Color (Clear Track Color)**

#### **Procedures**

- 1 **Open the T.TRK menu by performing the following menu operation.**

**T.TRK**

- 2 **Press the [5] key.**

The setting items for Clear Track Color will be displayed.

- 3 **Press the [numeric] key corresponding to the color of the target tracks to be cleared.**

The Confirmation Window will appear.

- 4 **Press the [1] key.**

All the tracks of the selected color will be cleared.

### **Clear of Tracks by Setting Track Number (Clear Track Number)**

#### **Procedures**

- 1 **Open the T.TRK menu by performing the following menu operation.**

**T.TRK**

- 2 **Press the [6] key.**

The setting items for Clear Track Number will be displayed.

- 3 **Press the [numeric] key corresponding to the number of the tracks to be cleared.**

The Confirmation Window will appear.

- 4 **Press the [1] key.**

The tracks of the selected number will be cleared.



## **[VII] Operation of Target Ship's Track Data Saved on Card (File Operations)**

Target ship's track data can be saved on a flash memory card and read from the card.

**Note:** Data can be saved to a flash memory card until the card becomes full, but the number of files that can be read and displayed is limited to 64 in alphanumeric order. When the number of files has reached 64, delete unnecessary files.

### **Loading File (Load)**

#### **Procedures**

#### **1 Insert a flash memory card into the card slot**

For the insertion and removal of the card, see HOW TO INSERT AND REMOVE A CARD in the appendix.

#### **2 Open the File Operations menu by performing the following menu operation.**

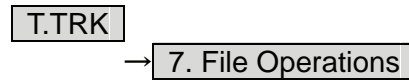

#### **3 Press the [1] key and select a card slot.**

The setting item for Select Card Slot is switched between Slot1 and Slot2.

#### **4 Press the [2] key and select Add or Overwrite.**

The setting item for Load Mode is switched between Add and Overwrite. When Add is selected, new data is added to the current data on the card. When Overwrite is selected, new data is saved over the current data on the card.

#### **5 Press the [3] key.**

Currently saved target ship's track data on the card will be listed.

#### **6 Press the [numeric] key corresponding to the file to be loaded.**

The Confirmation Window will appear.

#### **7 Press the [1] key.**

The selected target track data will be loaded and shown on the radar display.

---

## **Saving File (Save)**

### **Procedures**

- 1 Insert a flash memory card into the card slot.**

For the insertion and removal of the card, see HOW TO INSERT AND REMOVE A CARD in the appendix.

- 2 Open the File Operations menu by performing the following menu operation.**



- 3 Press the [1] key and select a card slot.**

The setting item for Select Card Slot is switched between Slot1 and Slot2.

- 4 Press the [4] key.**

The Save menu will appear.

- 5 Input the file name to be saved.**

Up to 10 characters can be input as a file name.  
For inputs to the characters input screen, refer to Section 3.3.4.  
After the input, the Confirmation Window will appear.

- 6 Press the [1] key.**

The currently displayed target track data will be saved.

## Erasing File (Erase)

### Procedures

- 1 **Insert the flash memory card into the card slot.**

For the insertion and removal of the card, see HOW TO INSERT AND REMOVE A CARD in the appendix.

- 2 **Open the File Operations menu by performing the following menu operation.**

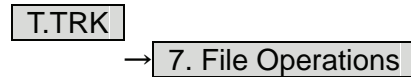

- 3 **Press the [1] key and select a card slot.**

The setting item for Select Card Slot is switched between Slot1 and Slot2.

- 4 **Press the [5] key.**

The Erase menu will appear.  
Currently saved target ship's track data on the card will be listed.

- 5 **Press the [numeric] key corresponding to the file to be erased.**

The Confirmation Window will appear.

- 6 **Press the [1] key.**

The selected target track data will be erased and the file name will disappear from the list.

---

## **Displaying File (Card Target Track Display)**

### **Procedures**

- 1 Insert the flash memory card into the card slot.**

For the insertion and removal of the card, see HOW TO INSERT AND REMOVE A CARD in the appendix.

- 2 Open the File Operations menu by performing the following menu operation.**



- 3 Press the [1] key and select a card slot.**

The setting item for Select Card Slot is switched between Slot1 and Slot2.

- 4 Press the [6] key.**

The Card T.TRK Display menu will appear.  
Currently saved target ship's track data on the card will be listed.

- 5 Press the [numeric] key corresponding to the file to be displayed.**

The Confirmation Window will appear.

- 6 Press the [1] key.**

The selected file will be highlighted, and the currently saved target track data will be displayed.

### **Cancellation**

- 1 Open the Card T.TRK Display window.**

The displayed file is highlighted.

- 2 Press the [numeric] key corresponding to the displayed file.**

The Confirmation Window will appear.

- 3 Press the [1] key.**

The file will be deselected and returned to normal display.

# 5.7 TRIAL MANEUVERING (TRIAL MANEUVER)

## Attention

- Trial maneuvering is to simulate own ship's course and speed in the conditions that the course and speed of a target ship are unchanged as they are. As the situation is different from any actual ship maneuvering, set values with large margins to CPA Limit and TCPA Limit.

5

The trial maneuvering is the function of simulating own ship's course and speed for collision avoidance when a dangerous target appears. When the own ship's course and speed are entered in manual mode, the trial maneuvering function checks if pre-acquired or pre-activated targets are dangerous.

The ranges of course and speed to be entered manually:

Course: 360° (in 0.1° intervals)..... [EBL] dial  
 Speed: 0 to 100 kn (in 0.1 kn steps)..... [VRM] dial

-----

## Trial Maneuvering in the True Vector Mode

In the True Vector mode, calculations are performed according to the values set by Trial Speed, Trial Course and other features, and the result is displayed as a bold-line that represents the change of own ship's vector as shown in the figure below (an example of the course changed to the right).

In this figure, the dangerous target forward left becomes safe as a result of simulation.

The tracked target information indicates the current CPA and TCPA values regardless of the result of simulation.

NORMAL

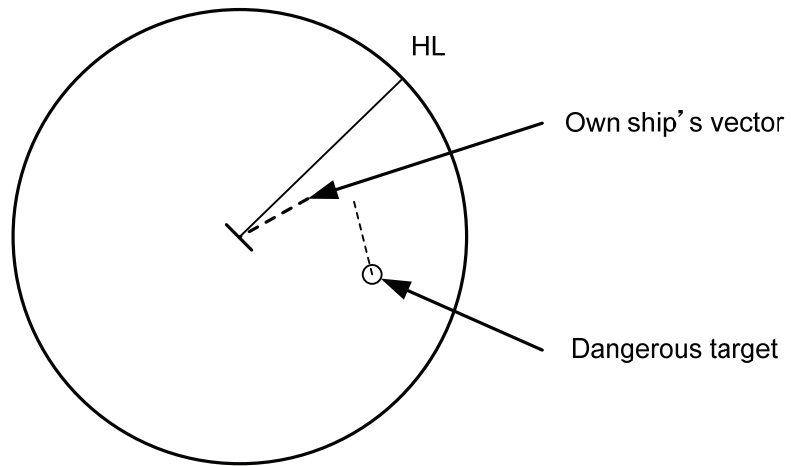

TRIAL

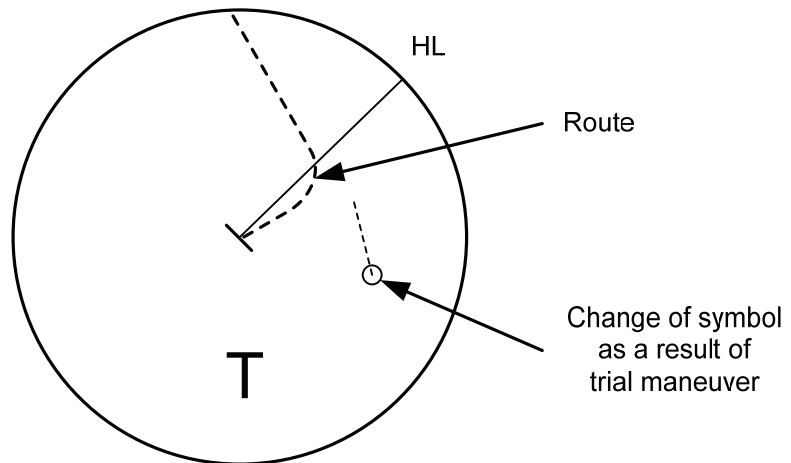

## Trial Maneuvering in the Relative Vector Mode

The result of Trial maneuvering in the Relative Vector mode is shown by a change in target vector. In the figure below (in the same conditions as in the True Vector mode in the previous page), it is seen that the acquired target is a dangerous one because its vector is crossing the CPA RING.

### NORMAL

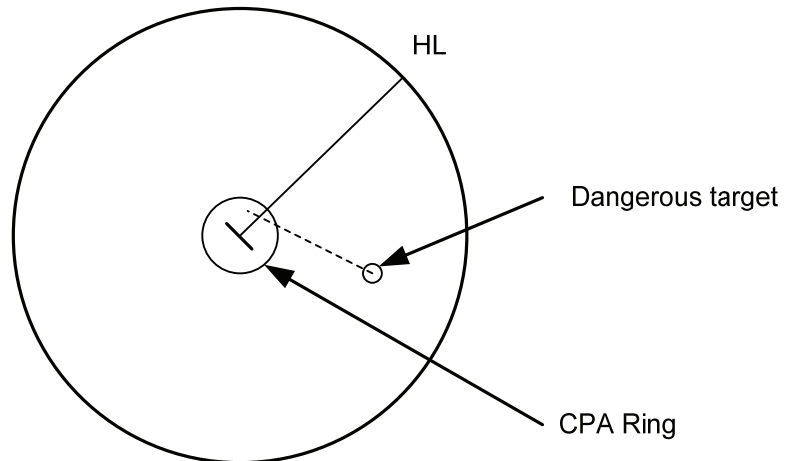

### TRIAL

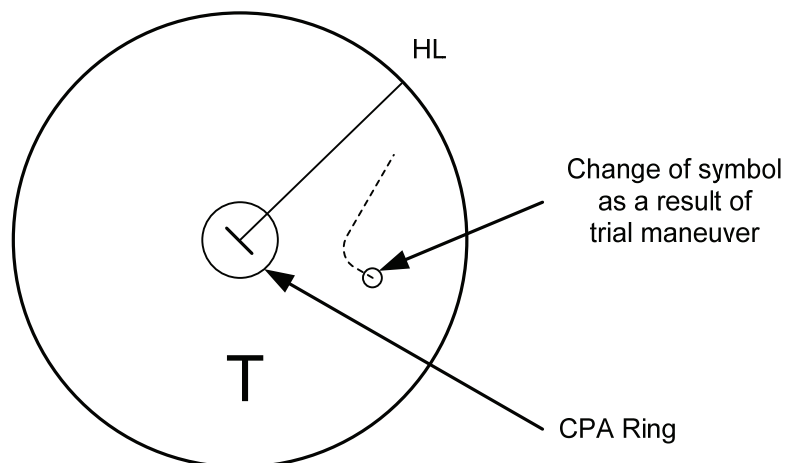

The above figure shows that the relative vector of the target has changed as shown in the figure as a result of simulation (course and speed), so that the symbol color is changed into “White”, a safe target.

Irrespective of the simulation results, the current CPA and TCPA values are shown in the tracked target information just like when the true vector mode is active.

The course change of own ship is displayed as a dotted-line.

Better information is provided by using relative motion and sea stabilization.

## Operation of Trial Maneuvering Function

### Procedures

- 1 Press the [TT MENU] key.
- 2 Open the Trial Maneuver menu by performing the following menu operation.

3. Trial Maneuver

- 3 Press the [1] key.

The Trial Function will be set to on or off.

:The trial maneuvering function is turned on.  
 :The trial maneuvering function is turned off.

When Trial Function is set to on, the character " T " indicating trial maneuvering blinks in the own ship display field of the radar display.

- 4 Set values for Course by turning the [EBL] dial, and for Speed by turning the [VRM] dial.
- 5 Set other characteristics.

<input type="button" value="Vector Time"/>	:Vector time (1 to 60 min)
<input type="button" value="Time to Maneuver"/>	:Time until trial maneuvering is started (0 to 30 min)
<input type="button" value="Own Ship Dynamic Trait&gt;"/>	:Dynamic trait of the own ship
→ <input type="button" value="Reach"/>	:Range from when steered to when the ship begins to turn (0 to 2000 m)
→ <input type="button" value="Turn Radius"/>	:Turning radius (0.10 to 2.00 nm)
→ <input type="button" value="Acceleration"/>	:Acceleration (0.0 to 100 kn/min)
→ <input type="button" value="Deceleration"/>	:Deceleration (0.0 to 100 kn/min)

For inputs to the value input screen, refer to Section 3.3.4.

Dangerous target symbols are displayed in red and safe target symbols in white.

- \* Vector Time is valid only when Trial Function is set to on. If it is off, the vector time before trial maneuvering is displayed.  
Time until the start of trial maneuvering is counted down immediately after the input.  
The acceleration and deceleration are influenced depending on the relationship between the current speed and the input speed for trial maneuvering.  
If 0.0 kn/min is set for  when the speed for trial maneuvering is faster than the current speed, or for  when the speed for trial maneuvering is slower than the current speed, the system performs simulation on the assumption that the speed is changed immediately after the time set for .

### Cancellation

- 1 Press the [1] key while the Trial Maneuver menu is displayed.

The Trial Function will be set to on or off.

:The trial maneuvering function is turned off.



# SECTION 6

## TRUE AND FALSE ECHOES ON DISPLAY

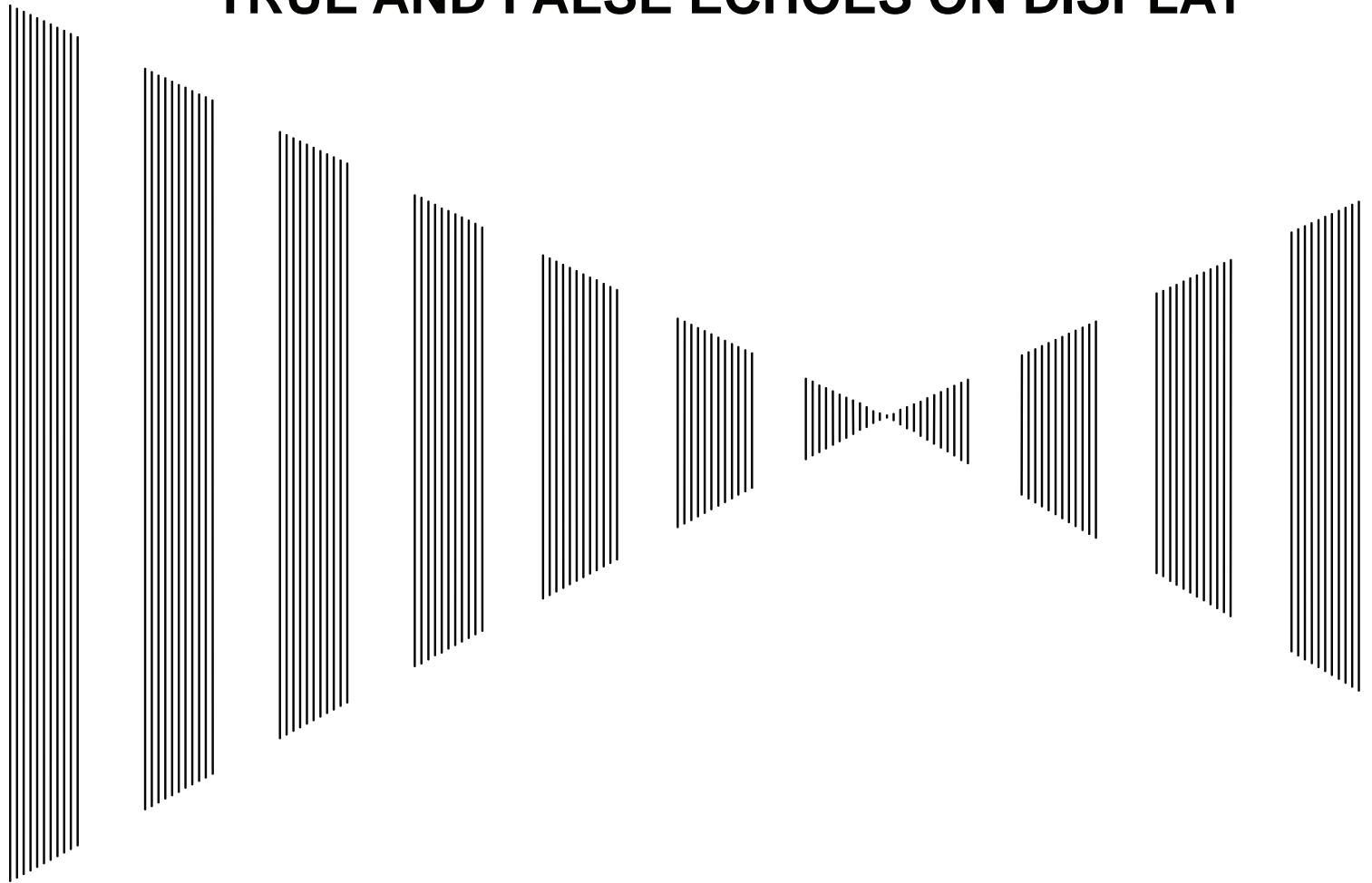

6.1	RADAR WAVE WITH THE HORIZON .....	6-1
6.2	STRENGTH OF REFLECTION FROM THE TARGET .....	6-3
6.3	SEA CLUTTER AND RAIN AND SNOW CLUTTER .....	6-5
6.4	FALSE ECHOES .....	6-9
6.5	DISPLAY OF RADAR TRANSPONDER (SART).....	6-12

The radar operator has a role of interpreting the radar displays to provide his best aid in maneuvering the ship. For this purpose, the operator has to observe the radar displays after fully understanding the advantages and disadvantages that the radar has. For better interpretation of radar display, it is important to gain more experiences by operating the radar equipment in fair weathers and comparing the target ships watched with the naked eyes and their echoes on the radar display.

The radar is mainly used to monitor the courses of own ship and other ships in open seas, to check buoys and other nautical marks when entering a port, to measure own ship's position in the coastal waters relative to the bearings and ranges of the shore or islands using a chart, and to monitor the position and movement of a heavy rain if it appears on the radar display.

Various types of radar display will be explained below.

## 6.1 RADAR WAVE WITH THE HORIZON

Radar beam radiation has the nature of propagating nearly along the curved surface of the earth. The propagation varies with the property of the air layer through which the radar beam propagates. In the normal propagation, the distance (D) of the radar wave to the horizon is approximately 10% longer than the distance to the optical horizon. The distance (D) is given by the following formula:

$$D=2.23(\sqrt{h_1} + \sqrt{h_2})(nm)$$

h1: Height (m) of radar scanner above sea level

h2: Height (m) of a target above sea level

Figure 6.1 is a diagram for determining the maximum detection range of a target that is limited by the curve of the earth surface in the normal propagation.

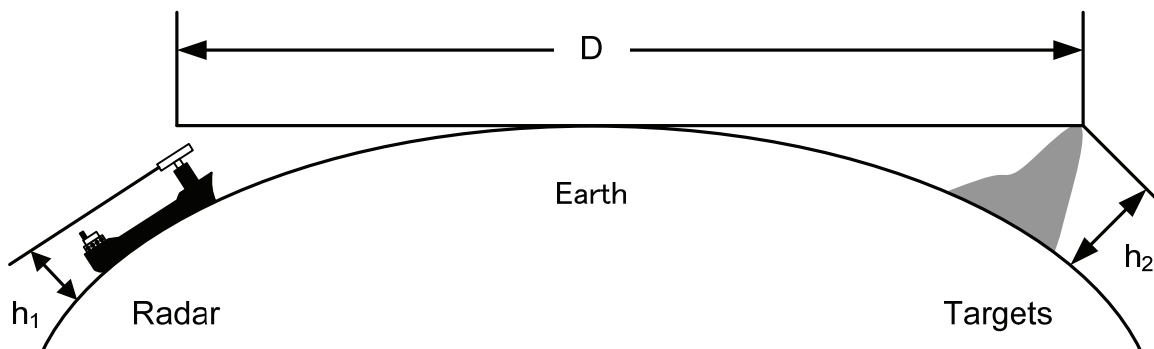

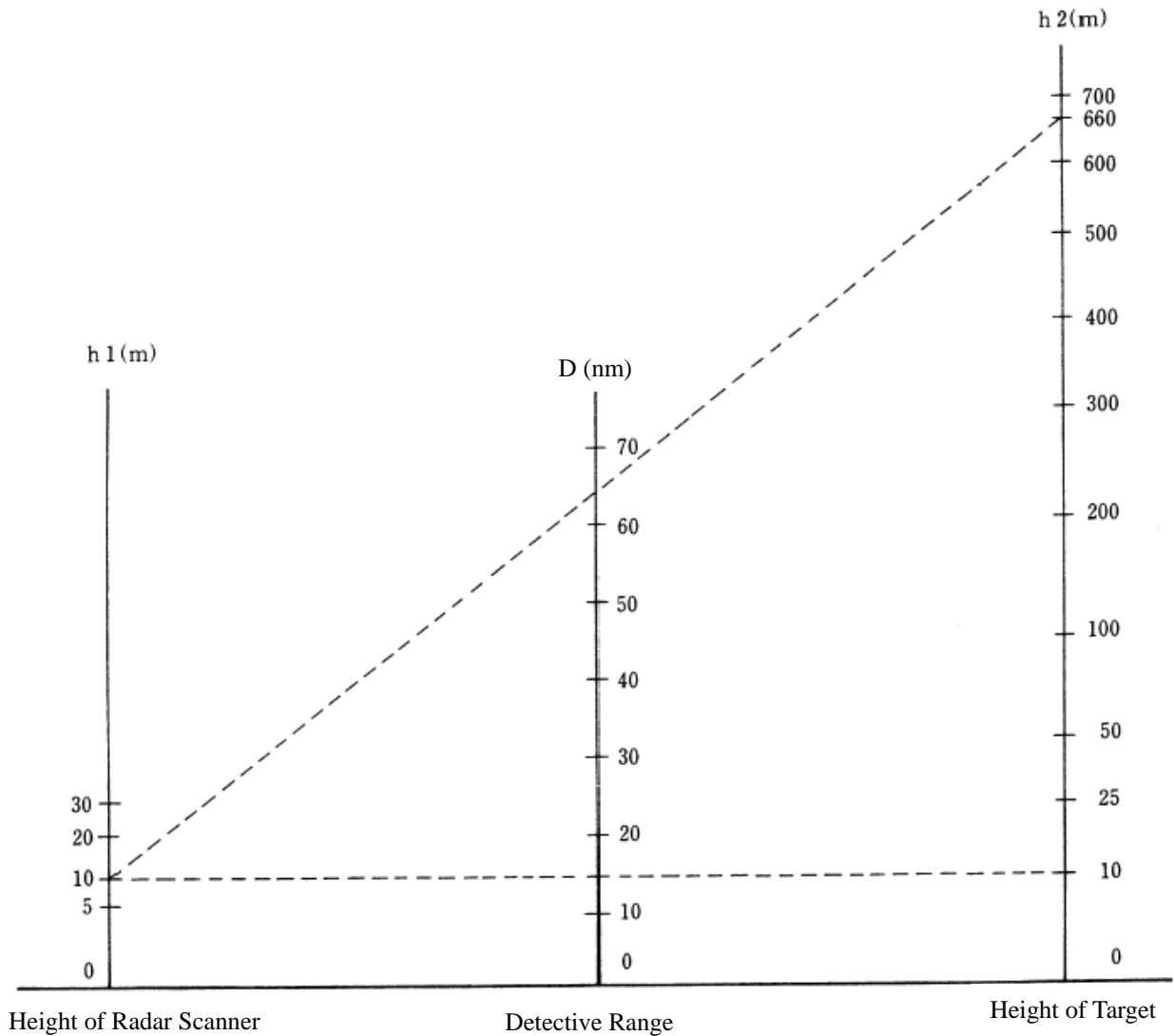

**Figure 6.1**

When the height of own ship's scanner is 10 m for instance,

- A target that can be detected at the radar range of 64 nm on the radar display is required to have a height of 660 m or more.
- If the height of a target is 10 m, the radar range has to be approx. 15 nm. However, the maximum radar range at which a target can be detected on the radar display depends upon the size of the target and the weather conditions, that is, the radar range may increase or decrease depending upon those conditions.

---

## 6.2 STRENGTH OF REFLECTION FROM THE TARGET

The signal intensity reflected from a target depends not only on the height and size of the target but also on its material and shape. The echo intensity from a higher and larger target is not always higher in general. In particular, the echo from a coast line is affected by the geographic conditions of the coast. If the coast has a very gentle slope, the echo from a mountain of the inland appears on the radar display. Therefore, the distance to the coast line should be measured carefully.

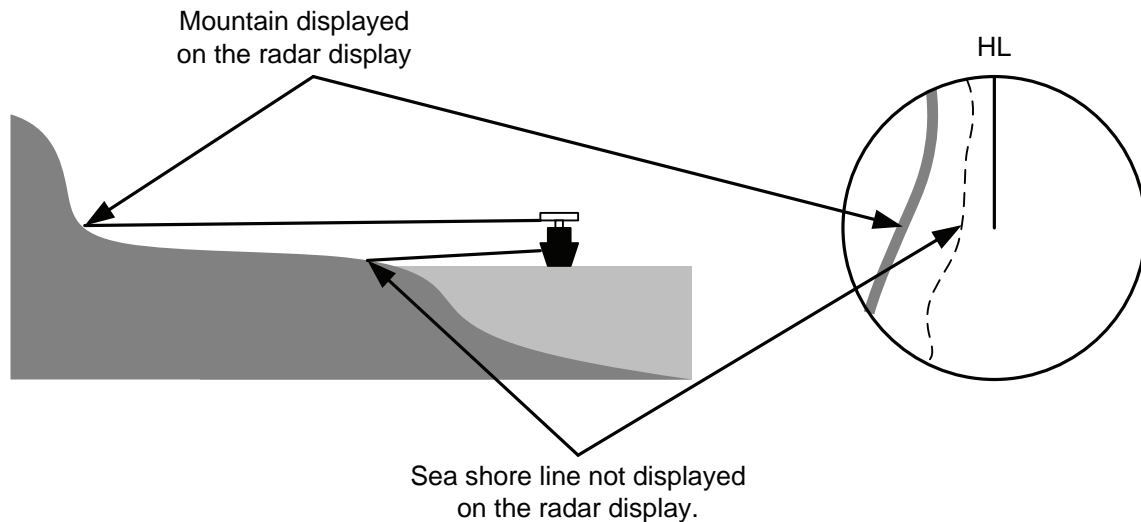

Figure 6.2

Table 6.1 shows the graph indicating the relation between the target detection distance and the radar reflection cross-sectional area (RCS) with regard to the type and the height of the target in a situation in which the weather is good, the sea state is calm and the radio wave propagation is normal. As revealed by this table, even on the same sea shore line, detection distance greatly differs depending on the height of the target from the surface of the sea. Furthermore, because the target detection distance is greatly influenced by the shape and material of the target and environmental conditions, such as the sea state, weather, and radio wave propagation, caution should be taken when detecting distance of target.

**Table 6.1 Relation between type and height of target and detection distance and RCS**

Type of target	Height from sea surface (m)	Detection distance (NM)		RCS (m <sup>2</sup> )	
		X band	S band	X band	S band
Sea shore line	60	20	20	50,000	50,000
Sea shore line	6	8	8	5000	5000
Sea shore line	3	6	6	2500	2500
SOLAS target ship (>5000GT)	10	11	11	50,000	30,000
SOLAS target ship (>500GT)	5	8	8	1800	1000
Small boat with IMO standard compatible radar reflector	4	5.0	3.7	7.5	0.5
Marine buoy with corner reflector	3.5	4.9	3.6	10	1
Standard marine buoy	3.5	4.6	3.0	5	0.5
10-meter small boat without radar reflector	2	3.4	3.0	2.5	1.4
Waterway location beacon	1	2.0	1.0	1	0.1

**Caution:** Detection distance shown in the above table may greatly decrease depending on the shape of the target, sea state, weather and radio wave propagation conditions.

# 6.3 SEA CLUTTER AND RAIN AND SNOW CLUTTER

In addition to the echo required for observing ships and land radar video image also includes unnecessary echo, such as reflection from waves on the sea surface and reflection from rain and snow. Reflection from the sea surface is called "sea clutter," and reflection from rain and snow is called "rain and snow clutter," and those spurious waves must be eliminated by the clutter rejection function.

## [I] Sea clutter

Sea clutter appears as an image radiating outwardly from the center of the radar display and changing depending on the size and the shape of waves. Generally, as waves become larger, image level of the sea clutter is intensified and the clutter far away is also displayed. When waves are large and the sea clutter level is high, it is difficult to distinguish sea clutter from a small boat whose reflection intensity is weak. Accordingly, it is necessary to properly adjust the sea clutter rejection function. Table 6.2 shows the relation between the sea state (SS) showing the size of waves generated by wind and the radar's detection probability.

**Table 6.2 Sea state and probability of target detection**

RCS	SS1 to 2	SS2 to 3	SS3 to 4	SS4 to 5
0.1m <sup>2</sup>	V	V-M	M-NV	
0.5 m <sup>2</sup>	V	V	V-M	M-NV
1 m <sup>2</sup>	V	V	V	V-M

S band radar (probability to detect a target at a distance of 0.4 NM)

RCS	SS1 to 2	SS2 to 3	SS3 to 4	SS4 to 5
1m <sup>2</sup>	V-M	M-NV		
5 m <sup>2</sup>	V	V-M	M-NV	
10 m <sup>2</sup>	V	V	V	V-M

X band radar (probability to detect a target at a distance of 0.7 NM)

- V: Detection probability of 80 %
- M: Detection probability of 50 %
- NV: Detection probability of less than 50 %

As shown in Table 6.3, the number of SS increases as the wind speed becomes high and the waves become large. Table 6.2 reveals that detection probability decreases from V (80 %) to NV (less than 50 %) as the number of SS increases. Therefore, even if the sea state is calm and a target clearly appears on the radar display, when the sea state becomes rough, target detection probability decreases resulting in difficulty of target detection by the radar.

**Table 6.3 Relation between Douglas sea state and average wind speed and significant wave height**

Sea state	Average wind speed (kn)	Significant wave height (m)
0	<4	<0.2
1	5-7	0.6
2	7-11	0.9
3	12-16	1.2
4	17-19	2.0
5	20-25	3.0
6	26-33	4.0

Significant wave height: an average of top N/3 higher waves when the number of waves detected within a constant time duration is N

For example, in the case of a standard marine buoy, RCS of X band radar is 5 m<sup>2</sup> as shown in Table 6.1. When observing such a target in the sea state (SS3) in which significant wave height exceeds 1.2 meters, detection probability is M-NV, as shown in Table 6.2, which indicates 50 % or less.

### **[II] Rain and snow clutter**

Rain and snow clutter is a video image that appears in a location where rain or snow is falling. The image changes according to the amount of rain (or the amount of snowfall). As precipitation increases, the image of rain and snow clutter becomes intensified on the radar display, and in the case of localized heavy rain, an image similar to the image indicating land is displayed in some cases. Furthermore, because radio waves tend to attenuate due to rain and snow, the ability to detect a target in the rain and snow clutter or a target beyond the rain and snow clutter may decrease. The amount of attenuation depends on the transmission frequency, antenna beam width, and the pulse length. Figure 6.3 and Figure 6.4 show examples in which detection distance is reduced due to the influence of precipitation. Because of this, a target, which clearly appeared up to 10 NM by an X band radar (pulse width of 0.8  $\mu$ s) when it was not raining, may become dimly visible up to 5 NM when the amount of rain becomes 4 millimeters per hour. Furthermore, when comparing the X band radar with the S band radar, target detection distance decreases less when an S band radar is used, which means it is influenced less by precipitation.

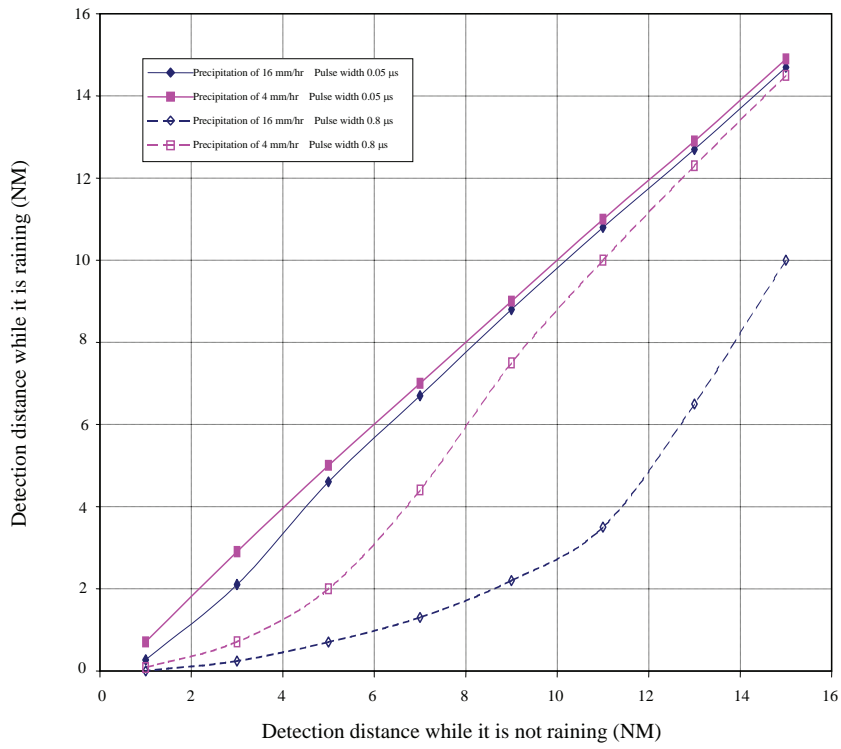

**Figure 6.3 Decreased target detection distance by S band radar due to precipitation**

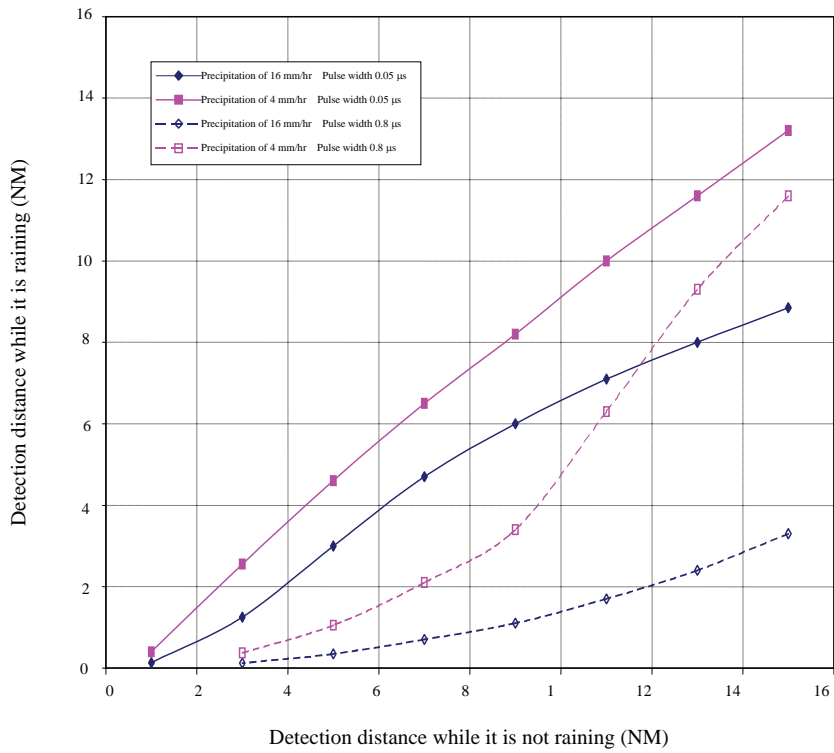

**Figure 6.4 Decreased target detection distance by X band radar due to precipitation**



### [III] Coping with sea clutter and rain and snow clutter

When the weather is bad and the ocean is rough, the use of an S band radar is effective because the radar is not influenced by sea clutter so much and attenuation due to rain drops is small. When an X band radar is used, reducing the pulse width will reduce the influence by spurious waves, and also the spurious wave rejection function effectively works; therefore, the use of short pulse is effective when the weather is bad. By using image processing functions PROC 1 to 3, it is expected that spurious waves are further suppressed. Since optimal settings for those items can be automatically made by using the function mode, it is recommended that STORM or RAIN be used by selecting the function mode when the weather is bad. For details of the function mode, see Chapter 3.9.

However, these functions may make some targets invisible, particularly targets with higher speeds.

---

## 6.4 FALSE ECHOES

The radar observer may be embarrassed with some echoes that do not exist actually. These false echoes appear by the following causes that are well known:

### [I] Shadow

When the radar scanner is installed near a funnel or mast, the echo of a target that exists in the direction of the funnel or mast cannot appear on the radar display because the radar beam is reflected on the funnel or mast. Whether there are some false echoes due to shadows can be checked monitoring the sea clutter returns, in which there may be a part of weak or no returns.

Such shadows appear always in the same directions, which the operator should have in mind in radar operation.

### [II] Side Lobe Effect

A broken-line circular arc may appear at the same range as the main lobe of the radar beam on the radar display. This type of false echo can easily be discriminated when a target echo appears isolated. (See Figure 6.5)

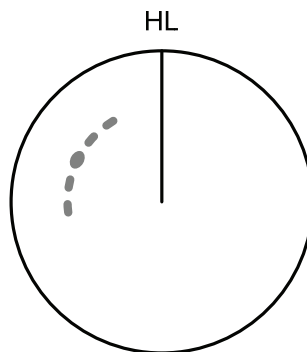

Figure 6.5

### [III] False Echo by Secondary Reflection

When a target exists near own ship, two echoes from the single target may appear on the radar display. One of those echoes is the direct echo return from the target and the other is the secondary reflection return from a mast or funnel that stands in the same direction as shown in Figure 6.6.

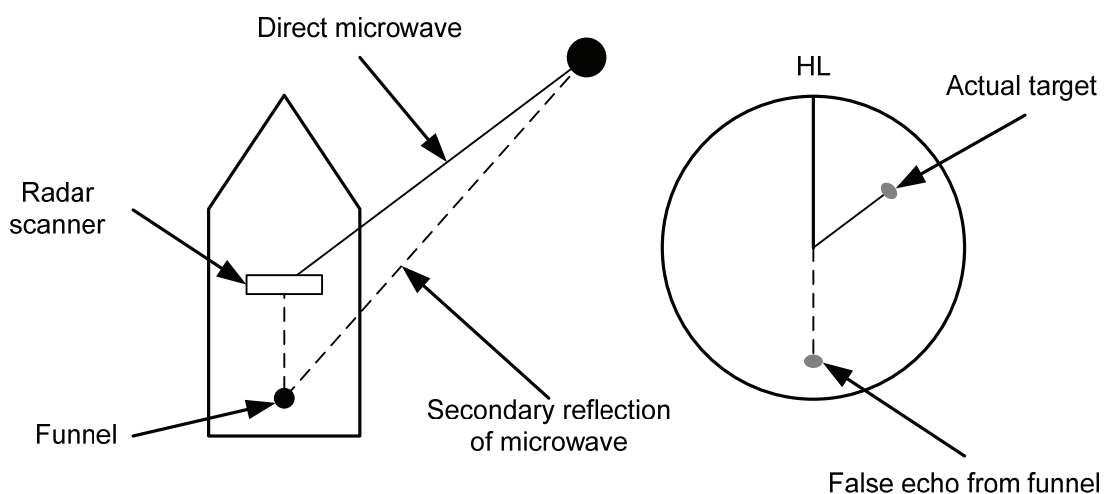

Figure 6.6



#### [IV] False Echo by Multiple Reflection

When there is a large structure or ship with a high vertical surface near own ship as shown in Figure 6.7, multiple reflection returns may appear on the radar display. These echoes appear in the same intervals, of which the nearest echo is the true echo of the target.

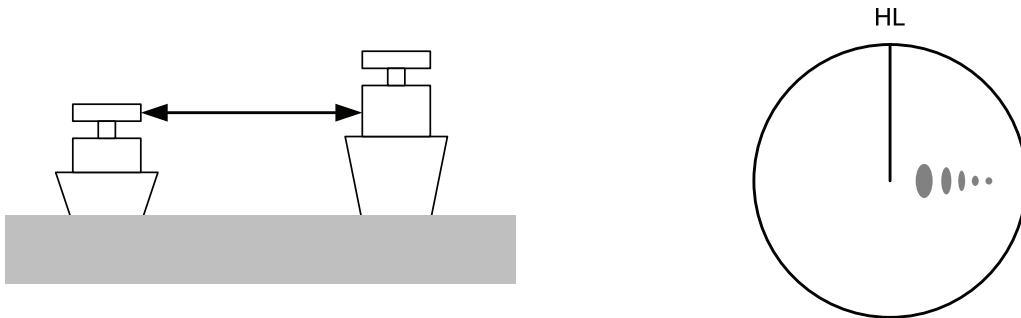

Figure 6.7

#### [V] Second Time Echoes

The maximum radar detection range depends upon the height of the scanner and the height of a target as described in the section of “The Horizon for Radar Beam Radiation”. If a so-called “duct” occurs on the sea surface due to a certain weather condition, however, the radar beam may propagate to an abnormally long distance, at which a target may be detected by the radar.

For instance, assuming that the pulse length is MP3 (on the repetition frequency of 1400 Hz), the first pulse is reflected from a target at about 58 NM or more and received during the next pulse repetition time. In this case, a false echo (second time echo) appears at a position that is about 58 NM shorter than the actual distance. If the false echo appears at 5 NM on the radar display, the true distance of the target is  $5+58=63$  NM. On the pulse length is SP1 (on the repetition frequency of 2250 Hz), a false echo may appear at a position that is about 36 NM shorter than the actual distance.

This type of false echo can be discriminated by changing over the range scale (the repetition frequency), because the distance of the target changes accordingly.

If second time echo is appeared, the use of Economy mode in PRF menu is effective. Otherwise, Stagger Trigger menu set to on. (See section 3.8.3)

---

## [VI] Radar Interference

When another radar equipment using the same frequency band as that on own ship is near own ship, a radar interference pattern may appear on the radar display. This interference pattern consists of a number of spots which appear in various forms. In many cases, these spots do not always appear at the same places, so that they can be discriminated from the target echoes. (See Figure 6.8)

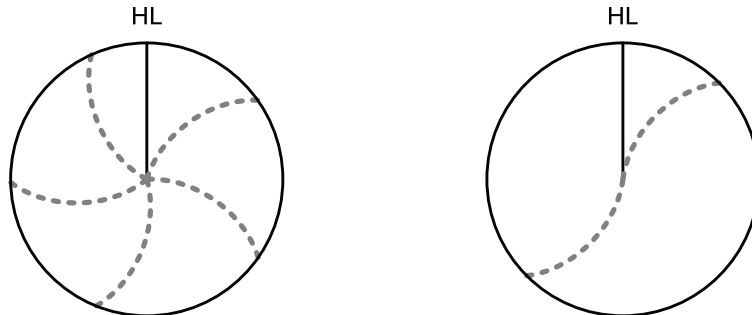

Figure 6.8

If radar equipment causing an interference pattern and this radar are of the same model, their transmitting repetition frequency is nearly the same. As a result, interference patterns may be displayed concentrically. In this case, the interference patterns cannot be eliminated by using only the interference reflector function, so press **[TX/PRF]** key several times to fine-tune the transmitting repetition frequency. An interference suppressing effect can be heightened by applying a different transmitting repetition frequency to the interference pattern source radar and this radar.

# 6.5 DISPLAY OF RADAR TRANSPONDER (SART)

The SART (Search and rescue Radar Transponder) is a survival device authorized by the GMDSS (Global Maritime Distress and Safety System), which is used for locating survivors in case that a distress accident occurs at sea. The SART is designed to operate in the 9 GHz frequency band.

When receiving the 9 GHz radar signal (interrogating signal) transmitted from the radar equipment on a rescue ship or search aircraft, the SART transmit a series of response signals to inform the distress position to the rescue and search party.

\* This radar provides a shortcut item to make settings for SART signal reception. Execution of this item automatically switches to the setting for SART reception. It also functions for detect the beacon or target enhancer.

## Procedures

- 1 Press [RANGE +] or [RANGE -] key to set the radar range to 6 NM or 12 NM.
- 2 Press [RADAR MENU] key twice, and then set the SART display mode according to the procedures below.

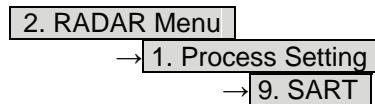

On	: SART ON
Off	: SART OFF

With the SART display mode set to ON, settings as shown below are made automatically.

- |  |                                      |
|--|--------------------------------------|
| (1) Sea clutter control:                             | Minimum (Most counterclockwise)      |
| (2) AUTO SEA function:                               | OFF                                  |
| (3) Rain and Snow Clutter Control (RAIN):            | minimum                              |
| (4) Auto Rain and Snow Clutter function (AUTO RAIN): | OFF                                  |
| (5) TUNE control:                                    | No tuning (to weaken clutter echoes) |
| (6) Interference rejecter (IR):                      | OFF                                  |
| (7) PROCESS:   | OFF                                  |



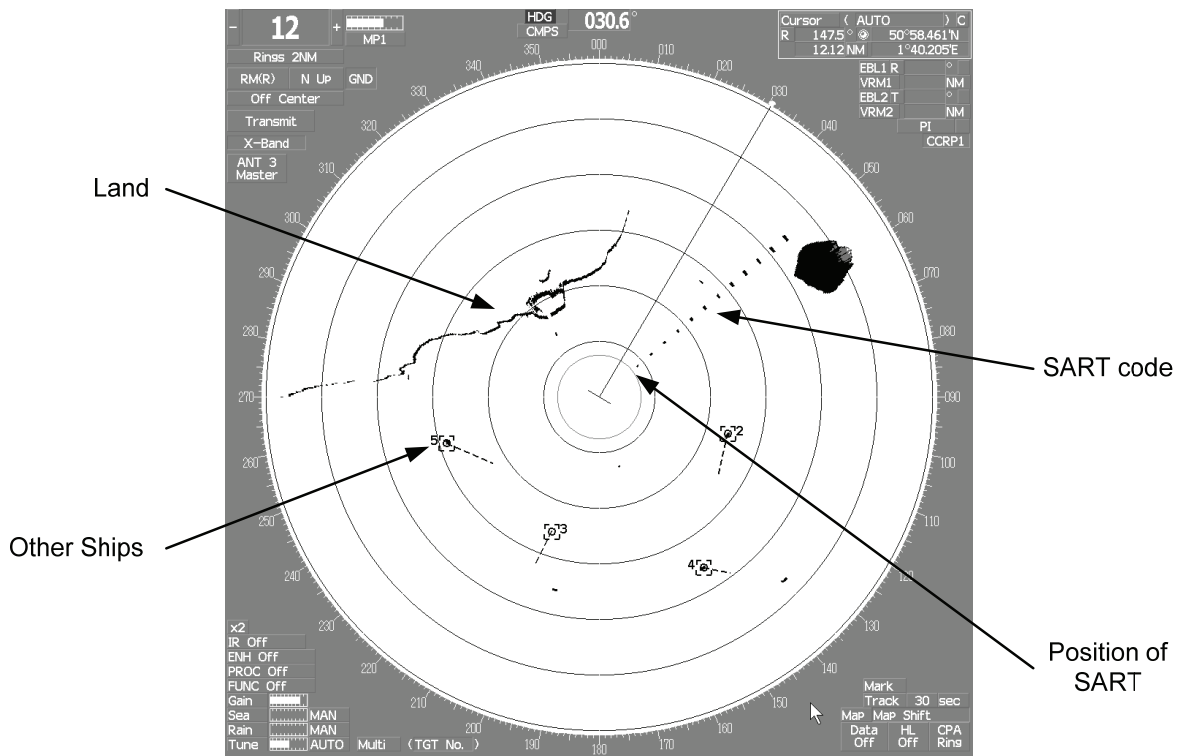

[Example of Display]

## Attention

- When the SART function is set to ON, small targets around own ship will disappear from the radar display. So it is necessary to exercise full surveillance over the conditions around own ship by visual watch in order to avoid any collision or stranding.

If two or more sets of radar equipment are installed on own ship, use one set of 9 GHz band radar for detection of the SART signal and operate others as normal radars for avoiding collision, monitoring targets around own ship, and checking on own ship's position and avoidance of stranding.

After end of detecting the SART signal, turn the SART display off. Then the radar returns normally to the nautical mode.

# SECTION 7

## SETTINGS FOR SYSTEM OPERATION

7.1	SETTINGS AT INSTALLATION .....	7-1
7.2	SETTINGS .....	7-10
7.3	ADJUSTMENT .....	7-22
7.4	MAINTENANCE MENU .....	7-30



---

# 7.1 SETTINGS AT INSTALLATION

This section describes the electrical adjustment procedures to be performed by service engineers during system installation.

The bearing adjustment value is saved to non-volatile memory in the scanner. Other settings are saved to non-volatile memory in the radar process unit.

## CAUTION

-  Do not carry out the adjustments of the equipment except authorized service persons. If wrong setting is carried out, this may cause unstable operation.
-  Do not carry out the adjustments during navigation. Otherwise, the radar performance may be affected, resulting in an accident or trouble.

### 7.1.1 How to Open the Serviceman Menu

#### Procedures

1. Press the [RADAR Menu] key for 2 seconds.

The Code Input menu will appear.

2. Press [0] key.

3. Put the cursor on the **ENT** button, and press the [ENT] key.

The Serviceman Menu will appear.

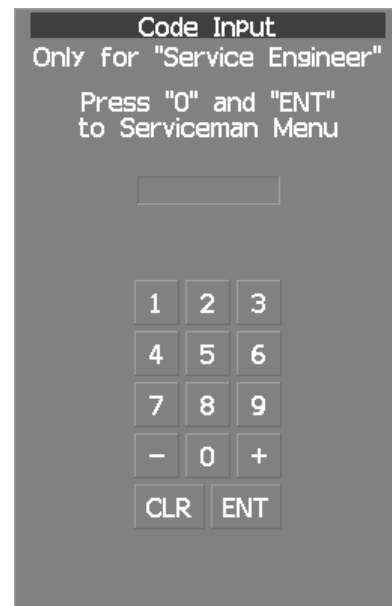



## 7.1.2 GYRO I/F Setting

The GYRO I/F circuit of the system is designed to be compatible with most types of gyro compasses by simply setting the switches.

Step motor type: 20 to 170 VDC

Synchro-motor type: Primary excitation voltage 35 to 120 VAC

Before power-on operation can be performed, the switches S1 to S5 on the GYRO I/F circuit (PC4201) must be set in accordance with the type of your gyro compass by performing the procedure below. The switches are factory-set for a gyration ratio of 180X and the step motor type. Make sure of the type of the gyro compass installed on the own ship before starting the procedure below.

### Procedures

#### 1. Set S1 to "OFF."

The gyro compass and GYRO I/F are turned off.

#### 2. Set S2 and S3 in accordance with the type of your gyro compass.

There are two types of gyro compasses: one type outputs a step signal, and the other type outputs a synchro signal. Make sure of the type of the gyro compass installed on the own ship before setting the switches S2 and S3.

Synchro signal: Set the switches to [SYNC].

Step signal: Set the switches to [STEP].

#### 3. Set the DIP switch S4.

The items to be set are listed below. For the settings, refer to Table 7-1.

S4-1:	LOG alarm ON/OFF
S4-2:	GYRO simulator ON/OFF
S4-3:	LOG simulator ON/OFF
S4-5:	Time before occurrence of GYRO alarm
S4-6:	Sensor to be used (GYRO/NMEA)
S4-7/8:	Baud rate when NMEA is used

#### 4. Set the DIP switch S5.

The items to be set are listed below. For the setting, refer to Table 7-2.

S5-1:	Type of gyro signal (step/synchro)
S5-2/3:	Gyration ratio of gyro compass
S5-4:	Gyration direction of gyro compass
S5-5:	Type of log signal (pulse/synchro)
S5-7/8:	Ratio of log signal

#### 5. Connect the gyro signal and log signal cables to the terminal block.

#### 6. Set S1 to "ON."

The gyro compass and GYRO I/F are connected.

#### 7. After power-on operation, set the true bearing according to Section 7.1.7.

#### 8. Make sure of the radar video and the operation with the true bearing value.

#### 9. If the true bearing value of the radar equipment is reversed, change the setting of the switch S5-4.

**Table 7-1 Setting Table (S4 DIP Switch)**

S4 SETTING	1	2	3	4	5	6	7	8
BSHLOG ALM	ON							
	OFF							
GYRO SIMULATOR		ON						
		OFF						
LOG SIMULATOR			ON					
			OFF					
N.C. (No Connection)				OFF				
GYRO ALM TIME			5 SEC		ON			
			0.2 SEC		OFF			
GYRO SRC (Heading Sensor Source)	HDT ( NMEA (HDT/THS) )					ON		
	GYRO					OFF		
NMEA BAUDRATE	4800 BPS						OFF	OFF
	9600 BPS						ON	OFF
	19200 BPS						OFF	ON
	38400 BPS						ON	ON

**Table 7-2 Setting Table (S5 DIP Switch)**

S5 SETTING	1	2	3	4	5	6	7	8	
GYRO SETTING	STEP		ON						
	SYNC		OFF						
	RATIO	36X		ON	ON				
		90X		OFF	ON				
		180X		ON	OFF				
		360X		OFF	OFF				
	DIRECTION		REV (Reverce)		ON				
NOR (Normal)			OFF						
LOG SETTING	SYNC (Synchro)				ON				
	PULSE				OFF				
	NC (No Connection)					OFF			
	PULSE/NM			100P / 30X		ON			ON
				200P / 90X		OFF			ON
				400P / 180X		ON			OFF
800P / 360X				OFF	OFF				

### 7.1.3 Tuning (Tune Adjustment)

Adjust the tuning control for the transmitter and receiver.

The turning control should be adjusted when the system is installed or when the magnetron is replaced.

#### Procedures

1. Set a range of 48 NM or more.
2. Open the Serviceman Menu.
3. Perform the following menu open procedure to open the Tune Adjustment menu.

```
1. Adjust Menu
  → 1. Tune Adjustment
```

4. Adjust the tune adjustment value so that the tune indicator bar at the upper left of the display is maximized.

For how to input numeric data on the numeric value input screen, see Section 3.3.4.

5. Move the cursor onto the **ENT** button, and press the [ENT] key.

#### [I] Tune Indicator Adjustment

Set the scale mark when the tune indicator bar reaches the maximum point.

#### Procedures

1. Set a range of 48 NM or more.
2. Open the Serviceman Menu.
3. Perform the following menu open procedure to open the Tune Indicator Adjust menu.

```
1. Adjust Menu
  → 4. TXRX Adjustment
     → 3. Tune Indicator Adjust
```

4. Adjust the tune indicator adjustment value so that the tune indicator bar at the upper left of the display reaches a point of 80 to 90% of the maximum.

For how to input numeric data on the numeric value input screen, see Section 3.3.4.

5. Move the cursor onto the **ENT** button, and press the [ENT] key.

---

- **With the JMA-5312 radar:**

For this model, perform Tune Peak Adjustment explained below.  
After the above adjustment procedure, perform the adjustment procedures below.

### **III] Tune Peak Adjustment**

Adjust the tune indicator and echo peak.

#### **Procedures**

1. **Set a range of 48 NM or more.**
2. **Open the Serviceman Menu.**
3. **Perform the following menu open procedure to open the Tune Peak Adjustment menu.**

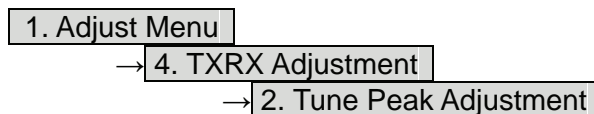

4. **Adjust the tune peak adjustment value so that the tune indicator bar at the upper left of the display is maximized.**

For how to input numeric data on the numeric value input screen, see Section 3.3.4.

5. **Move the cursor onto the **ENT** button, and press the [ENT] key.**

## **7.1.4 Bearing Adjustment**

Make adjustment so that the bearing of the target measured with the ship's compass matches the bearing of the target echo on the radar display.

#### **Procedures**

1. **Select H Up for the bearing presentation. Set video processing (PROC) to OFF.**
2. **Measure the bearing of an adequate target (e.g., a ship at anchor, a breakwater, or a buoy) relative to own ship's heading.**
3. **Open the Serviceman Menu.**
4. **Perform the following menu open procedure to open the Bearing Adjustment menu.**

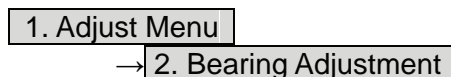

5. **Adjust the bearing adjustment value so that the target measured in step 2 is adjusted to the correct bearing.**

For how to input numeric data on the numeric value input screen, see Section 3.3.4.  
Make adjustment by the 0.1°.

6. **Move the cursor onto the **ENT** button, and press the [ENT] key.**

## 7.1.5 Range Adjustment

Make adjustment so that the range of a target on the radar display is shown correctly.

### Procedures

1. Search the radar display for a target of which range is already known.
2. Open the Serviceman Menu.
3. Perform the following menu open procedure to open the Range Adjustment menu.

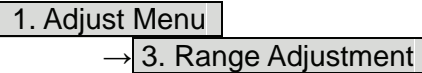

4. Adjust the range adjustment value so that the target measured in step 1 is adjusted to the correct range. (For inputs to the value input screen, refer to Section 3.3.4.)
5. Move the cursor onto the **ENT** button, and press the [ENT] key.

## 7.1.6 Navigator Setting (Device)

Determine whether to connect navigators to the radar equipment.  
Only the navigators set to ON here can be used.

### Procedures

1. Open the Serviceman Menu.
2. Perform the following menu open procedure to open the Device Installation menu.

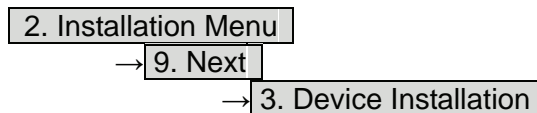

3. Select **On** for navigators connected to the radar equipment, and **Off** for navigators not connected.

GYRO:	Gyro (via GYRO I/F)
Compass:	Compass (Compliant with IEC61162)
GPS Compass:	GPS compass produced by JRC
Log:	Log (via GYRO I/F)
2AXW:	2-axis log (Speed over water: Compliant with IEC61162)
2AXG:	2-axis log (Speed over ground: Compliant with IEC61162)
GPS:	GPS (Compliant with IEC61162)

---

## 7.1.7 Setting of True Bearing Value

If GYRO I/F is used to input a gyro signal, the true bearing value indicated by the master gyro does not match the value indicated by the radar equipment only in a rare case. In this case, perform the following procedure to adjust the true bearing value of the radar equipment to the value of the master gyro.

### Procedures

1. Press the [RADAR MENU] key twice, and perform the following menu open procedure to open the true bearing value setting menu.

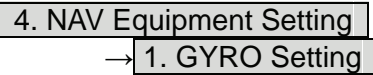

2. Input the master gyro value to the value input screen. (For inputs to the value input screen, refer to Section 3.3.4.)
3. Move the cursor onto the **ENT** button, and press the [ENT] key.

## 7.1.8 Antenna Height Setting (Antenna Height)

Set the height of radar antenna above sea level. Do not change this setting carelessly.

### Procedures

1. Measure the height of radar antenna above sea level in advance.
2. Open the Serviceman Menu.
3. Perform the following menu open procedure to open the Antenna Height setting menu.

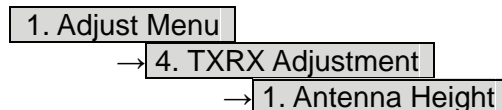

4. Select the setting that matches the antenna height measured in step 1.

## 7.1.9 Setting of CCRP/Antenna/GPS Antenna Position (CCRP Setting)

Set the own ship's CCRP location, radar antenna installation location, and GPS installation location.

- CCRP: Up to four locations can be input. (One location selected when used)  
 Radar antenna: Up to eight radar antennas can be input. (Automatically selected in response to ISW operation)  
 GPS: Up to four locations can be input. (One location selected when used)

### Procedures

1. Measure the CCRP location, radar antenna location, and GPS antenna location in advance.
2. Open the Serviceman Menu.
3. Perform the following menu open procedure to open the CCRP Setting menu.

2. Installation Menu

→ 4. CCRP Setting

4. Specify the ship length for Length at the upper right of the CCRP Setting Menu, and the ship width for Beam.
5. Move the cursor onto the CCRP1 X, Y value, and press the ENT key to input the CCRP1 location.

When  $X > 0$ , the CCRP is on the starboard side of the ship. When  $X < 0$ , it is on the port side.

6. To input the second CCRP, press the **CCR2** button to display the CCRP2 X,Y value, and input the value in the same manner for step 5.

Similarly, input the third and subsequent CCRPs.

7. Repeat the above steps to input the GPS location(s) and radar antenna location(s).
8. If multiple CCRP locations and GPS locations are input, select the CCRP location and GPS location to be used by pressing the buttons at the upper left of the menu.
9. Press [0] key to close the CCRP Setting menu.

例：  
Example:

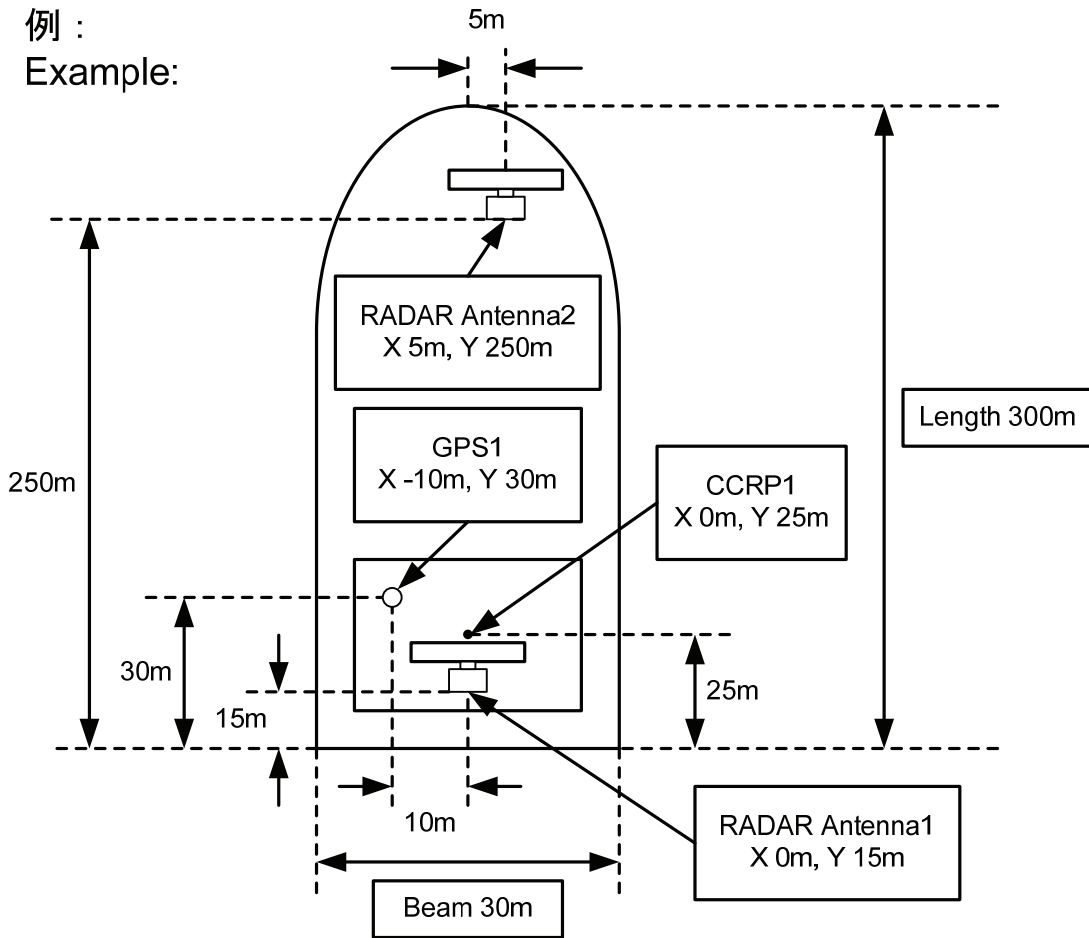

**CCRP Settings**

1. Select CCRP  Length   
 2. Select GPS  Beam

	X	Y
GPS1	-10.0	30.0 m
GPS2		m
GPS3		m
GPS4		m

	X	Y
RADAR Antenna1	0.0	15.0 m
RADAR Antenna2	5.0	250.0 m
RADAR Antenna3		m
RADAR Antenna4		m
RADAR Antenna5		m
RADAR Antenna6		m
RADAR Antenna7		m
RADAR Antenna8		m

	X	Y
CCRP1	0.0	25.0 m
CCRP2		m
CCRP3		m
CCRP4		m

0.

**Legend:**  
 ● GPS  
 ● RADAR Antenna  
 ● CCRP





# 7.2 SETTINGS

This section describes the electrical adjustment procedures to be performed by service engineers during system installation.



## CAUTION

- 

**Do not carry out the adjustments of the equipment except authorized service persons. If wrong setting is carried out, this may cause unstable operation.**
- 

**Do not carry out the adjustments during navigation. Otherwise, the radar performance may be affected, resulting in an accident or trouble.**

## 7.2.1 Communication Port Setting (COM Port Setting)

External sensor signals are input to the radar equipment through a communication port. The radar equipment has five communication ports. For signals to be input from sensors or to be output to the sensors, communication ports need to be set in accordance with the sensors.

### **[I] Baud Rate Setting**

Set the baud rate of the signal to be input to the COM port.

#### **Procedures**

1. Open the Serviceman Menu.
2. Perform the following menu open procedure to open the Baud Rate setting menu.

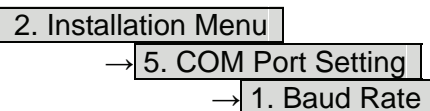

---

### 3. Set the baud rate of the port to be set.

#### Selection value

1. COMPASS : 4800(NMEA)/9600(NSK)/**38400(Fast NMEA)** bps
2. NAV1 : 1200/**4800**/9600/38400 bps
3. NAV2 : 1200/**4800**/9600/38400 bps
4. GPS : 1200/**4800**/9600/38400 bps
5. NMEA : 1200/**4800**/9600/38400/115200 bps

The bold values are factory-set.

The compass port is a receive-only port that is dedicated to COMPASS signals.

## **[III] Reception Port Setting (RX Port)**

Set the numbers of ports for receiving signals from sensors.

There are two methods for receiving signals: specifying a port for each sensor, or using the automatic recognition function without specifying ports.

### **Procedures**

1. Open the Serviceman Menu.
2. Perform the following menu open procedure to open the RX Port setting menu.

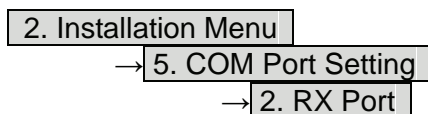

3. Set a port for each sensor.

Settable sensor signals

GPS, DLOG, Alarm, Depth, Temperature, Wind, Current, ROT, RSA

Selectable ports

When the automatic recognition function is used: AUTO

When ports are specified: NAV1, NAV2, GPS, and NMEA

### Reception Sentence Setting (RX Sentence)

Set signal sentences to be received from sensors.

The system is factory-set for using all sentences.

To receive only specified sentences, select  for sentences which are not necessary.

#### Procedures

1. Open the Serviceman Menu.
2. Perform the following menu open procedure to open the RX Sentence setting menu.

2. Installation Menu

→ 5. COM Port Setting

→ 3. RX Sentence

3. Select the sentences to be used by the sensors to be set.

Selection value: (Use) or (No Use) can be set for each sentence.

- |                     |  |
|---------------------|--|
| 1. GPS(LL/COG/SOG): | GGA/RMC/RMA/GNS/GLL/VTG  |
| 2. GPS(WPT/Time):   | GGA/RMC/RMB/BWC/BWR/ZDA  |
| 3. Depth:           | DPT/DBK/DBT/DBS  |
| 4. Wind:            | MWV/MWD  |
| 5. Current:         |  |
| Data Set Number:    | 0-9. Set the number of the sentence to be used by Data Set Number. (Initial value All)           |
| Layer A:            | 0-999. Set the number of the sentence to be used with layer A by Layer Number. (Initial value 3) |
| Layer B:            | 0-999. Set the number of the sentence to be used with layer B by Layer Number. (Initial value 4) |
| Layer C:            | 0-999. Set the number of the sentence to be used with layer C by Layer Number. (Initial value 5) |

---

## **[IV] Transmission Port Setting (TX Port)**

For each sentence, set a communication port through which signals are transmitted to sensors.

### **Procedures**

1. **Open the Serviceman Menu.**
2. **Perform the following menu open procedure to open the TX Port setting menu**

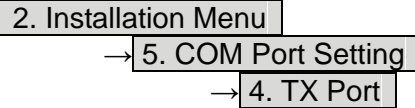

3. **Select the communication port through which the sentence to be set is output.**

#### **Settable sentences**

TTM(TT), TLL(TT), TTD(TT), TLB(TT), OSD, RSD, ALR, ACK,  
TTM(AIS), TLL(AIS), TTD(AIS), TLB(AIS), RemoteMaintenance,  
JRC-ARPA, APB, BOD, GGA, GLL, RMC, RMB, VTG, XTE,  
BWC, HDT, THS

#### **Selectable ports**

NAV1, ARPA, GPS, and NMEA

4. **Select the output format, talker, and transmission interval.**

Signals for which the above items can be set:

- **NMEA0183 Output Format**  
Signal names: APB, BOD, GGA, GLL, RMC, RMB, VTG, XTE, BWC, HDT, THS  
Selection Value: V1.5, V2.0, and V2.3
- **NMEA0183 Talker**  
Signal names: APB, BOD, RMB, XTE, BWC, HDT, THS  
Selection Value:  
Standard: The talker is RA.  
GP: The talker is GP.  
For TTM, TLL, TTD, TLB, OSD, RSD and ALR the talker is always RA .  
For GGA, GLL, RMC, and VTG, the talker is always GP.
- **NMEA0183 TX Interval**  
Signal names: APB, BOD, GGA, GLL, RMC, RMB, VTG, XTE, BWC, HDT, THS  
Selection Value: Set an interval in the range 1 to 9 seconds.

## **[V] GPS Receive Port Setting (Select NAV Equipment)**

Select the receive port of GPS data.

### **Procedures**

1. Open the Serviceman Menu.
2. Perform the following menu open procedure to open the COM Port setting menu

2. Installation Menu

→ 5. COM Port Setting

3. Press the [5] key.

Units of Select NAV Equipment are switched.

Internal GPS

: The receive port is selected GPS connector of processor unit (JRC's GPS).

External GPS

: The receive port is selected GPS terminal of terminal board circuit.

## **7.2.2 Sector Blank Setting (Sector Blank)**

In order not to display radar echoes, set a sector and stop transmission in the bearing. Three sector blank areas can be created.

The sector blank function operates in the relative bearing with the bow.

### **[I] Sector Blank Function On/Off (Sectors 1, 2, and 3)**

### **Procedures**

1. Open the Serviceman Menu.
2. Perform the following menu open procedure to open the Sector Blank setting menu.

2. Installation Menu

→ 3. Sector Blank

3. Set the sector blank number **1**, **2**, or **3** with which the sector blank function operates.

The system allows the use of up to three sector blank areas.

Set each sector blank area to on or off.

On: The sector blank function is operated.

Off: The sector blank function is stopped.

---

### [II] Sector Blank Area Creation (Make Sectors 1, 2, and 3)

#### **Procedures**

1. Transmit the radar.
2. Open the Serviceman Menu.
3. Perform the following menu open procedure to open the Sector Blank setting menu.

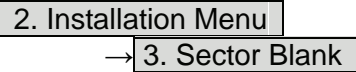

4. Press numeric keys corresponding to the desired sector creation **Make Sector N**.

The selected sector blank will be made.

5. Set the starting bearing of the sector blank by operating the [EBL] dial, and press the [ENT] key.
6. Set the ending azimuth of the sector blank by operating the [EBL] dial, and press the [ENT] key.

### 7.2.3 TNI Blank Setting (TNI Blank)

Set a sector and stop tuning operation in the bearing.

If a structure such as the mast is close to the radar antenna, automatic tuning operation may become unstable. In this case, set a TNI blank in the direction of the structure in order to stabilize the tuning operation.

Only one TNI blank sector can be created. The TNI blank function operates in the relative bearing with the bow as the benchmark.

### [I] TNI Blank Function On/Off (Sector)

#### **Procedures**

1. Open the Serviceman Menu.
2. Perform the following menu open procedure to open the TNI Blank setting menu.

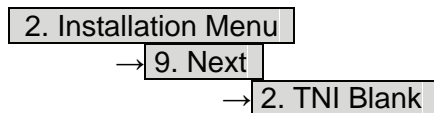

3. Select the item **1. TNI Blank** in the menu, and turn on or off the TNI blank function.

On: The TNI blank function is operated.

Off: The TNI blank function is stopped.

### [III] TNI Blank Area Creation (Make Sector)

#### Procedures

1. Transmit the radar.
2. Open the Serviceman Menu.
3. Perform the following menu open procedure to open the TNI Blank setting menu.

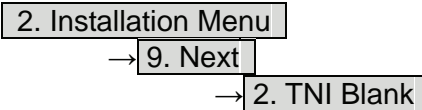

4. Press the **2. Make Sector** button in the menu.
5. Set the starting bearing of the TNI blank by operating the [EBL] dial, and press the [ENT] key.
6. Set the ending bearing of the TNI blank by operating the [EBL] dial, and press the [ENT] key.

## 7.2.4 Setting of Bearing Pulses from Antenna (Output Pulse)

Set the output value of bearing pulses from the antenna. The system can set 2048 pulses or 4096 pulses. This setting is enabled only when an antenna of 25 or 30 kW is used.

#### Procedures

1. Open the Serviceman Menu.
2. Perform the following menu open procedure to open the Output Pulse setting menu.

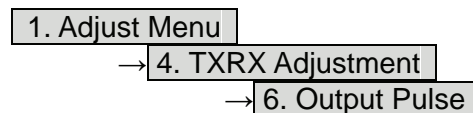

3. Set the number of pulses to be output by the antenna.

2048: 2048 pulses per antenna rotation (Recommended value)

4096: 4096 pulses per antenna rotation

\* If a 10 kW antenna is used, **2048** is always set.

---

## 7.2.5 Slave Mode Setting (Master/Slave)

Place the system in the  mode when it is to be operated as the sub-display that displays radar echoes by using radar signals from other radar equipment.

The input value of externally input bearing pulses can be set. The system can set 2048 pulses or 4096 pulses.

### [I] Slave Mode Setting (Master/Slave)

#### **Procedures**

1. Open the Serviceman Menu.
2. Perform the following menu open procedure to open the installation setting menu.

3. Select Slave for the item  in the menu.

Master: The system operates as radar equipment while the own antenna is connected.

Slave: The system operates as a sub-display while the signal cable of other radar equipment is connected.

### [II] Setting of Input Bearing Pulse (Input BP Count)

#### **Procedures**

1. Open the Serviceman Menu.
2. Perform the following menu open procedure to open the second page of the installation setting menu.

→

3. Set the number of pulses for the item  in the menu.

2048: 2048 pulses per antenna rotation

4096: 4096 pulses per antenna rotation



## 7.2.6 Language Setting (Language)

The system is designed to switch between display languages, Japanese and English.

### Procedures

1. Open the Serviceman Menu.
2. Perform the following menu open procedure to open the language setting menu.

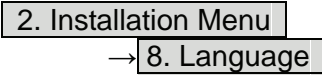

3. Select the language to be used.

1. English
2. Japanese
3. Other

**3. Other** is an option to display character strings created by our agents. Ask the agent or our sales department if your language is supported.

4. To determine the selected language, turn the radar off, and then turn it on.

## 7.2.7 Date Time Setting

To display time, the local time, local date, and time-zone difference must be set. However, if the "ZDA" sentence of NMEA0183 is received, time can be automatically displayed.

### Procedures

1. Press the [RADAR MENU] key twice, and then perform the following menu open procedure to open the Date/Time Setting menu.

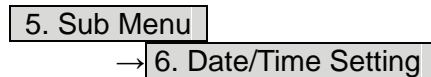

---

## 2. Set information about date and time.

- [1] **UTC/LMT (Time display system)**  
UTC: Universal Time Coordinate  
LMT: Local Mean Time
- [2] **LMT Date**  
Input the date in local time.
- [3] **LMT Time**  
Input the time in local time.
- [4] **Time Zone**  
Input the time-zone difference between the universal time and local time.
- [5] **Display Style**  
Set one of the following date display formats.

YYYY-MM-DD	Example: 2007-12-31
MMM DD, YYYY	Example: Dec 31, 2007
DD MMM, YYYY	Example: 31 Dec, 2007
- [6] **Synchronize with GPS**  
A ZDA sentence sent by the GPS is used, thereby displaying time synchronized with the GPS time.
  - On: Time synchronized with the GPS time
  - Off: Time not synchronized with the GPS time

\* If  **On** is selected for this item but a ZDA sentence is not input, the system internal clock function is used to display the date and time.

## 7.2.8 Input Installation Information

The system can input installation information.

### Procedures

1. **Open the Serviceman Menu.**
2. **Perform the following menu open procedure to open the language setting menu.**

→

3. **Input the installation information.**

For the input method on the numeric value and character input screens, see Section 3.3.4.

- [1] **Date**  
Input the date of installed system.
- [2] **Name**  
Input the name of installation personnel.
- [3] **Company**  
Input the name of radar installer.

## 7.2.9 Setting the Alarm System

### Setting the relay output (Relay Output)

This function enables the control of ARPAALM terminal (on the terminal board circuit).

#### Procedures

1. Open the Serviceman Menu.
2. Perform the following menu open procedure to open the language setting menu.

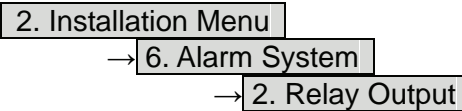

3. Press the [1] key.

The Relay Output mode is switched.

Continuous	: The output is continuously controlled.
Intermittent	: The output is intermittently controlled.

4. Press the [numeric] key corresponding to the item to be changed.

The item can be turned on / off.

On	: The relay output is turned on when alarm have issued.
Off	: The relay output is not turned on when alarm have issued.

- |                 |   |
|-----------------|---|
| 2. TT CPA/TCPA  | : There is a dangerous target. (tracked target)               |
| 3. AIS CPA/TCPA | : There is a dangerous target. (AIS target)                   |
| 4. New Target   | : A new target is acquired in the automatic acquisition zone. |
| 5. Lost         | : There is a lost target. (Target Tracking / AIS).            |
| 6. RADAR Alarm  | : Targets have entered the radar alarm range.                 |

### Setting the ALR output (ALR Output)

This function enables the control of ALR port (See the section 7.2.1).

#### Procedures

1. Open the Serviceman Menu.
2. Perform the following menu open procedure to open the language setting menu.

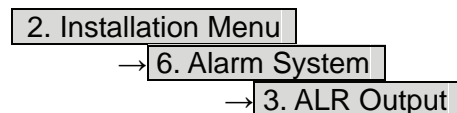

3. Press the [numeric] key corresponding to the item to be changed.

The item is turned on / off.

On	: The ALR sentence is output when alarm have issued.
Off	: The ALR sentence is not output when alarm have issued.

- |                 |   |
|-----------------|---|
| 1. System Alarm | : The internal alarm.                             |
| 2. TT/AIS Alarm | : Target Tracking Alarms and AIS Function Alarms. |

---

## Setting the External Acknowledgement (External ACK Setting)

This function enables the control of system when ACK sentence have received.

### **Procedures**

1. Open the Serviceman Menu.
2. Perform the following menu open procedure to open the language setting menu.

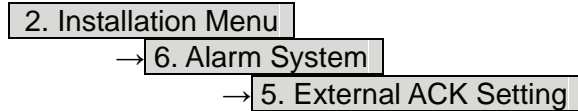

3. Press the [numeric] key corresponding to the menu to be changed.

Critical Alarm	: CPA/TCPA alarm.
Normal Alarm	: Exept Critical Alarm.

4. Press the [numeric] key corresponding to the item to be changed.

The item is switched.

Audio	: Setting of alarm sound.
On	: The alarm sound is not stopped when acknowridgement have received.
Off	: The alarm sound is stopped when acknowridgement have received.



Indication	: Setting of alarm indication.
Lighting	: The alarm indication brinking is stopped when acknowridgement have received.
Brinking	: The alarm indication brinking is not stopped when acknowridgement have received.

Acknowridge State	: Setting of ALR sentence.
A:ACK	: Add acknowridgement to ALR sentence.
V:UNACK	: Add no acknowridgement (unrecognized) to ALR sentence.

# 7.3 ADJUSTMENT

This section describes the electrical adjustment procedures to be performed by service engineers during system installation.

## CAUTION

-  Do not carry out the adjustments of the equipment except authorized service persons. If wrong setting is carried out, this may cause unstable operation.
-  Do not carry out the adjustments during navigation. Otherwise, the radar performance may be affected, resulting in an accident or trouble.

7

### 7.3.1 Noise Level Adjustment (Noise Level)

#### [I] Noise Level Adjustment for Signal Processing

##### **Procedures**

1. Open the Serviceman Menu.
2. Perform the following menu open procedure to open the noise level adjustment menu.

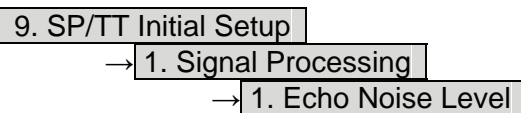

3. Increase/decrease the noise level adjustment value.

The noise level is factory-set.

After system installation, a great change in the noise level adjustment value should be avoided; it should be fine adjusted within  $\pm 5$ .

---

### **III] Noise Level Adjustment Mode (Setting Mode)**

A noise level is factory-adjusted while this mode is turned on.

#### **Procedures**

- 1. Open the Serviceman Menu.**
- 2. Perform the following menu open procedure to open the noise level adjustment menu.**

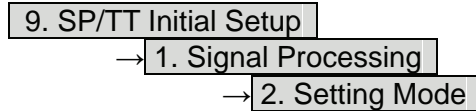

The noise level adjustment mode is switched between on and off.

Factory-adjustment method

- The GAIN control is set to the maximum position, the SEA control is set to the minimum position, the RAIN control is set to the minimum position, and IR, AUTO-SEA, AUTO-RAIN, PROC, FUNC, and TRAILS are all set to off.
- The noise level adjustment mode is turned on.
- While the noise level adjustment value is decreased gradually, the value with which radar echoes no longer appear is determined as the set value.
- Ten is added to the set value (with which radar echoes no longer appear), and the result is set as the final noise level adjustment value.
- The noise level adjustment mode is turned off when the adjustment is finished.

## 7.3.2 Adjustment of Target Tracking Function (TT)

### [I] Vector Constant Adjustment (Vector Constant)

Adjust the vector follow-up performance of the target tracking function.  
The vector constant is adjusted to an optimal value, so do not change it carelessly.

#### Attention

- **Do not change the set value carelessly.**  
The vector constant shall be set to 4 normally. If the vector constant value is higher, a target's vector will be better followed up when the target and own ship change their course or speed, but the vector accuracy will be lower on the contrary.

#### Procedures

1. Open the Serviceman Menu.
2. Perform the following menu open procedure to open the Vector Constant adjustment menu.

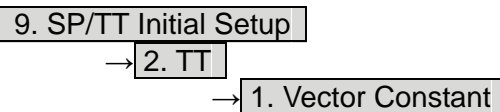

The window for setting vector constants will appear.

3. **Input the value to be set.**

To improve vector follow-up performance, increase the set value.  
To stabilize vectors, decrease the set value.

---

### **III] Quantization Level Adjustment (Video Level)**

Use the target tracking function (TT) to adjust the level of the signal to be recognized as a target. If a small value is set, even weak target signals will be input to the target detection circuit of the target tracking function. However, many unnecessary signals are also input, which may cause unstable target acquisition or tracking. It is important to set a value four or five greater than the value with which unnecessary signals are detected. The quantization level is adjusted to an optimal value, so do not change it carelessly.



## **CAUTION**



**Do not change the set quantization level carelessly. If the level deviates from the proper value, the target acquisition and tracking functions will deteriorate. Otherwise, this may cause accidents.**

#### **Procedures**

1. Open the Serviceman Menu.
2. Perform the following menu open procedure to open the target tracking setting menu.

9. SP/TT Initial Setup

→ 2. TT

3. To change the **quantization level** of the automatic acquisition area, specify the item **2. Video TD Level** in the menu. To change the quantization level of tracking and manual acquisition, specify the item **3. Video High Level**.



**III] Gate Size Adjustment (Gate Size)**

Use the target tracking function (TT) to set a target search area.  
The gate size is adjusted to an optimal value, so do not change it carelessly.

**Procedures**

1. Open the Serviceman Menu.
2. Perform the following menu open procedure to open the Gate Size setting menu.

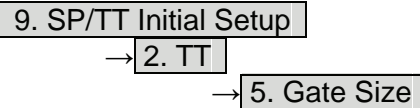

3. Select a gate size.

Narrow: Small gate size  
Normal: Medium gate size  
Wide: Large gate size

**IV] CPA Limit Ring Display On/Off (Limit Ring)**

Use the target tracking function (TT) to determine whether to display the CPA limit for determining a dangerous ship. When the CPA limit ring display function is turned on and a relative vector is used, the CPA limit ring is displayed as a red circle.

**Procedures**

1. Open the Serviceman Menu.
2. Perform the following menu open procedure to set the limit ring display to ON/OFF.

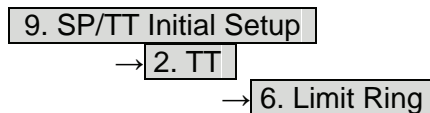

Off: Limit ring not displayed  
On: Limit ring displayed

---

### 7.3.3 Main Bang Suppression Adjustment (MBS)

Main Bang Suppression is adjusted to suppress main bang, a reflection signal from 3D circuit including wave guide tube, that generally appears as a circular video focusing on the center of the radar display. Optimum adjustment allows main bang video to remain slightly on the display.



## CAUTION



**Do not change this adjusted level carelessly. Incorrect adjustment may erase targets in point-blank range and cause collision, resulting in death or serious injury.**

#### Procedures

1. Open the Serviceman Menu.
2. Perform the following menu open procedure to open the MBS adjustment menu.

9. SP/TT Initial Setup

→ 3. MBS

3. Set the radar as follows:
  - Set the radar video enhance function and video processing (PROC) to OFF.
  - Turn the [RAIN] control to the minimum position (fully to the left).
  - Turn the [GAIN] control to the maximum position (fully to the right).
  - Turn the [SEA] control to achieve the strength with which main bang can be judged.
4. Set 20 for **2. MBS Area**.
5. Adjust the value set for **1. MBS Level** so that the main bang remains slightly.
6. Adjust the value set for **2. MBS Area** so that the suppression area will match the main bang.

## 7.3.4 Adjustment of Performance Monitor (MON)

After replacement of either of the following units, adjust the performance monitor according to the procedures in this section:

- Performance monitor
- Antenna unit

### II Reception Monitor Adjustment (MON Adjustment)

Adjust the circuit for monitoring the reception performance of the radar equipment.

#### Procedures

1. If the performance monitor is equipped with an inter-switch function, set it as the master display unit.
2. Open the Serviceman Menu.
3. Perform the following menu open procedure to open the Performance Monitor Adjustment menu.

1. Adjust Menu

→ 4. TXRX Adjustment

→ 4. MON Adjustment

4. Increase or decrease the adjustment value so that the farthest point of the performance monitor pattern touches the 18.0 nm line.

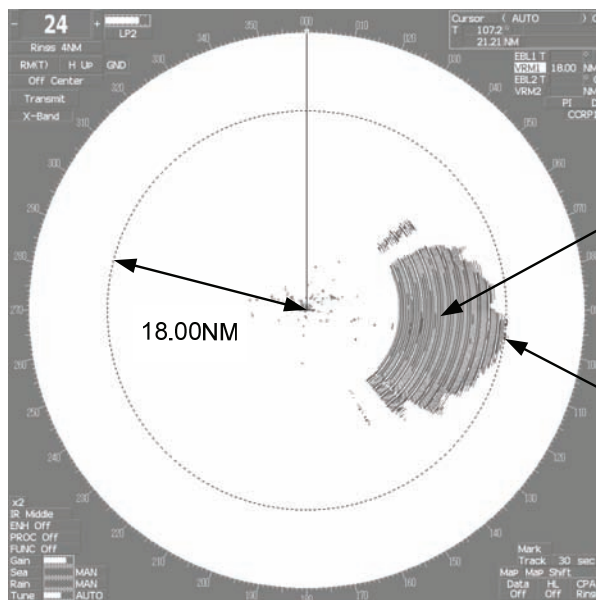

**Note:** During performance monitor adjustment, all acquisitions by the target tracking function are released.  
The released target acquisitions are not recovered.

---

### **III] Transmission Monitor Adjustment (MON Indicator Adjustment)**

Adjust the circuit for monitoring the transmission performance of the radar equipment.

#### **Procedures**

1. If the performance monitor is equipped with an inter-switch function, set it as the master display unit.
2. Open the Serviceman Menu.
3. Perform the following menu open procedure to open the performance monitor Indicator Adjustment menu.

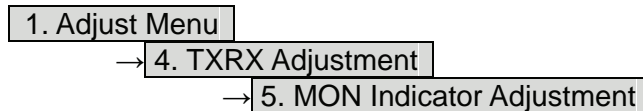

4. Increase or decrease the adjustment value so that the performance monitor level indicator will be adjusted to "8."

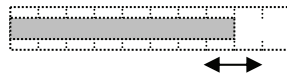

Adjusted to 8

5. Press the **Exit** button to close the adjustment menu.

**Note:** During performance monitor adjustment, all acquisitions by the target tracking function are released.  
The released target acquisitions are not recovered.

# 7.4 MAINTENANCE MENU

This item is provided for equipment maintenance, including settings of antenna safety switch, master reset, etc.



## CAUTION

- 

**Only our service engineers are to make the adjustment. Neglecting this caution may cause accidents and failures.**
- 

**Do not make the adjustments during navigation. Otherwise, adjustments may affect the radar functions, causing accidents and failures.**

## 7.4.1 Antenna Safety Switch (Safety Switch)

Use this switch to measure the transmission/reception performance while the antenna is in stopped state.

### Procedures

1. Open the Serviceman Menu.
2. Perform the following menu open procedure to open the Safety Switch setting menu.

3. Maintenance Menu

→ 1. Safety Switch

3. Select the item to be set.

Set operation when the antenna safety switch is turned off.

1. TX-Off :

The transmitter stops transmission.

The display unit remains in transmission state.

2. Standby : (Normal setting)

The transmitter stops transmission.

The display unit is placed in standby state.

3. TX-On :

The transmitter continues transmission.

The display unit remains in transmission state.

4. Change the setting back to 2. Standby when the work is finished.

---

## 7.4.2 Initialization of Memory Area (Area Initial)

If system operation is unstable, it may be stabilized by initializing the memory area. To initialize the memory area, follow the procedure in this section. The memory area is reset to the factory setting when initialized.

### [I] Partial Master Reset

#### Procedures

1. Open the Serviceman Menu.
2. Perform the following menu open procedure to open the Partial Master Rest operation menu for the memory area.

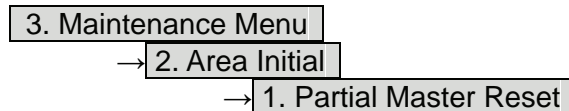

3. Select the items to be initialized.

Serviceman Menu:	The set values in the Serviceman menu are initialized.
Except Serviceman Menu:	The set values not in the Serviceman menu are initialized.
User Setting:	The user setting values are initialized.
TT Setting:	The set values for the target tracking function are initialized.
AIS Setting:	The set values for the AIS function are initialized.
Day/Night:	The color scheme and brilliance setting for the day/night mode are initialized.
JRC Card Copy Record:	The history of JRC charts copied on the memory card is erased.

4. Select **Yes** in the Confirmation Window.

The memory areas of specified items are initialized, and the system is restarted.

### [II] All Master Reset

#### Procedures

1. Open the Serviceman Menu.
2. Perform the following menu open procedure to open the All Master Rest operation menu for the memory area.

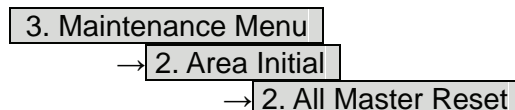

3. Select **Yes** in the Confirmation Window.

The whole memory area is initialized, and the system is restarted.

### 7.4.3 Save of Internal Memory Data (Card1/2)

The system can save internal memory data such as item settings in all menus onto a flash memory card. If the radar processing circuit in the system has been replaced, the set values before the circuit replacement can be restored by reading the set values you saved before the replacement.

To save the internal memory data onto a flash memory card (option), the card must be inserted in card slot beforehand.

#### [I] Copying of Internal Settings onto Card (Internal to Card1/2)

Save the internal memory data, such as item settings in menus, onto a flash memory card.

The internal memory data should be saved at completion of system setting, and the operation condition should be saved periodically.

##### **Procedures**

1. Open the Serviceman Menu.
2. Perform the following menu open procedure to select the slot of the card on which the internal memory data is to be saved.

3. Maintenance Menu  
→ 3. Internal to Card1/2

The lower slot is slot 1; the upper slot is slot 2.

3. Select **Yes** in the Confirmation Window.

The internal memory data is saved on the flash memory card.

#### [II] Reading of Internal Settings from Card (Card1/2 to Internal)

Read the saved memory data from the flash memory card into the system memory.

Perform the read operation in order to return the system to the previous operation condition after replacement of the radar processing circuit in the system.

##### **Procedures**

1. Open the Serviceman Menu.
2. Perform the following menu open procedure to select the slot of the card from which the previously saved internal memory data is to be read.

3. Maintenance Menu  
→ 4. Card1/2 to Internal

The lower slot is slot 1; the upper slot is slot 2.

3. Select **Yes** in the Confirmation Window.

The memory data is read from the flash memory card into the system memory. After the internal memory area is updated, the system is restarted.

---

## 7.4.4 Clear and Save/Restoration of Antenna Operation Time (TXRX Time)

The system adds up the following operation time and contains it in the antenna unit:

- Transmission time
- Motor run time

Clear the above total time when the magnetron or antenna unit motor is replaced.

### [I] Clear of Transmission Time (Clear TX Time)

Clear the transmission time of the antenna unit.

Perform the following procedure to clear the transmission time when the magnetron is replaced.

#### **Procedures**

1. Open the Serviceman Menu.
2. Perform the following menu open procedure to open the Clear TX Time menu.

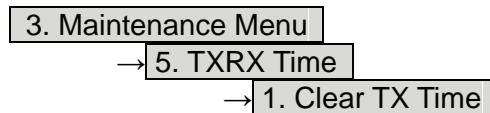

3. Select **Yes** in the Confirmation Window.

The transmission time in the antenna's internal control circuit is cleared to 0.

### [II] Clear of Motor Run Time (Clear Motor Time)

Clear the antenna's motor run time.

Perform the following procedure to clear the motor run time when the antenna motor is replaced.

#### **Procedures**

1. Open the Serviceman Menu.
2. Perform the following menu open procedure to open the Clear Motor Time menu.

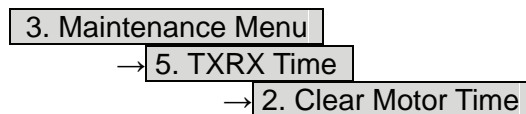

3. Select **Yes** in the Confirmation Window.

The motor run time in the antenna's internal control circuit is cleared to 0.



**III] Save of Antenna Time (TXRX to Display Unit)**

Save the following antenna time data from the antenna unit into the display unit.

- Antenna's operating hours
- Transmission time
- Motor run time

Perform the following procedure to inherit the antenna time data when the antenna's internal control circuit is replaced.

1. Saving the antenna time data
2. Replacing the antenna's internal control circuit
3. Restoring the antenna time data

**Procedures**

1. Open the Serviceman Menu.
2. Perform the following menu open procedure to open the TXRX to Display Unit menu.

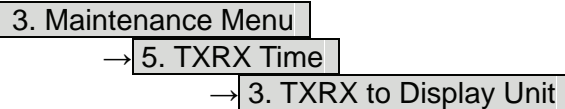

3. Select **Yes** in the Confirmation Window.

The antenna time data in the antenna's internal control circuit is saved transferred to the display unit.

**IV] Restoration of Antenna Time (Display Unit to TXRX)**

Restore the antenna time data from the display unit into the antenna's internal control circuit.

Perform the following procedure to inherit the antenna time data when the antenna's internal control circuit is replaced.

1. Saving the antenna time data
2. Replacing the antenna's internal control circuit
3. Restoring the antenna time data

**Procedures**

1. Open the Serviceman Menu.
2. Perform the following menu open procedure to open the Display Unit to TXRX menu.

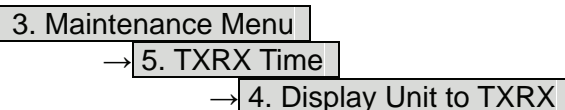

3. Select **Yes** in the Confirmation Window.

The antenna time data in the display unit is restored transferred to the antenna's internal control circuit.

---

## 7.4.5 Update of Character String Data (String Data Update)

The system is designed to transfer and display external character strings as the second language display. The second language is factory-set to "Japanese."

Ask our agent or sales department for the supply of character strings to be updated.

To update character strings, the flash memory card (option) containing the character string file must be inserted in card slot 2.

### Procedures

1. Open the Serviceman Menu.
2. Perform the following menu open procedure to open the String Data Update menu.

3. Maintenance Menu

→ 6. String Data Update

3. Select **Yes** in the Confirmation Window.

The character string file on the flash memory card is read into the system, and the second language area is updated.

To display the read character strings in the second language, select **Other** in the menu shown in Section 7.2.6.

# SECTION 8 MAINTENANCE

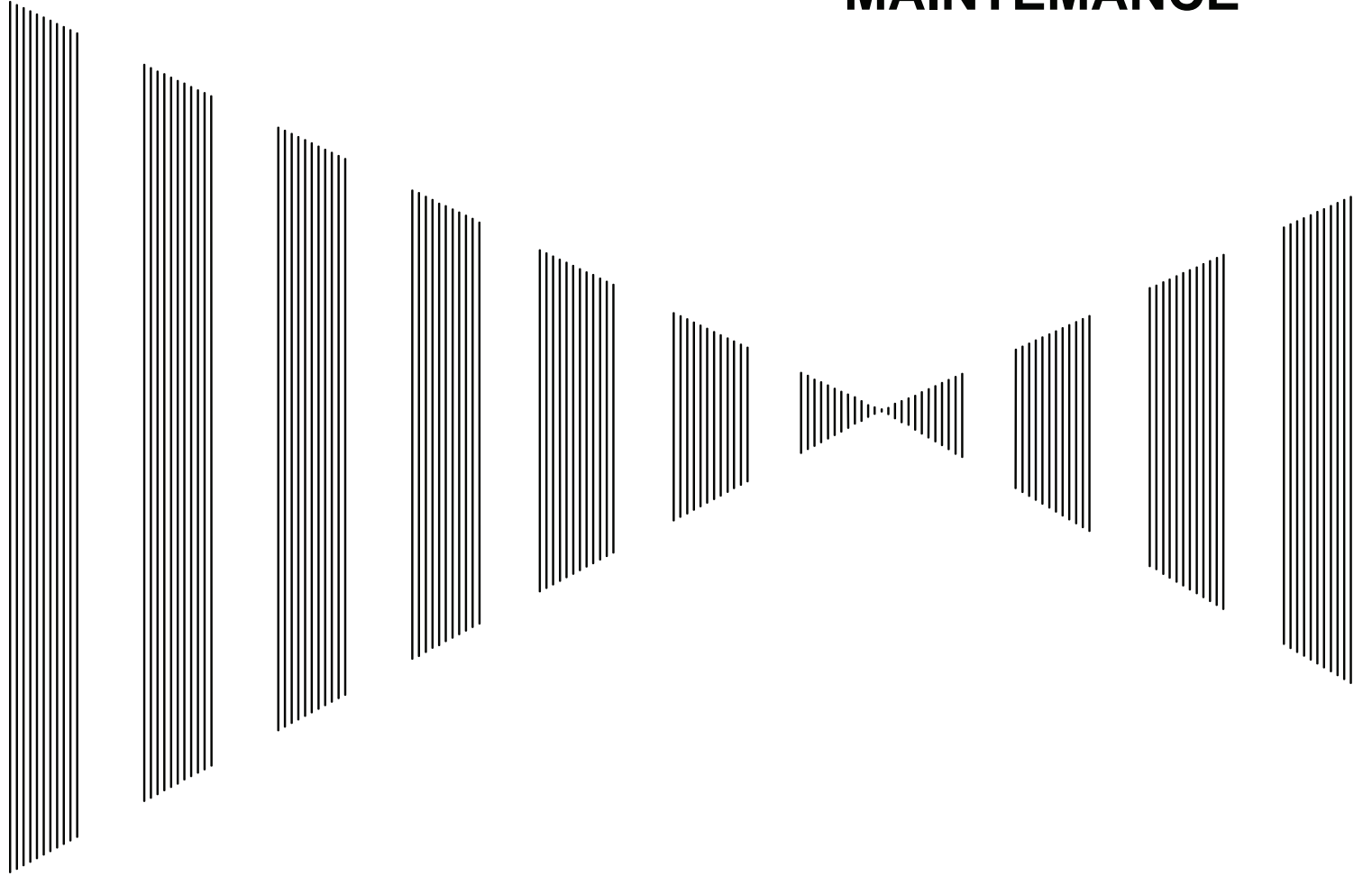

<b>8.1</b>	<b>ROUTINE MAINTENANCE .....</b>	<b>8-1</b>
<b>8.2</b>	<b>MAINTENANCE ON EACH UNIT .....</b>	<b>8-2</b>
<b>8.3</b>	<b>PERFORMANCE CHECK .....</b>	<b>8-6</b>
<b>8.4</b>	<b>REPLACEMENT OF MAJOR PARTS .....</b>	<b>8-11</b>

---

## **8.1** ROUTINE MAINTENANCE



### **WARNING**



**Never carry out internal inspection or repair work of the equipment by users.**

**Inspection or repair work by unauthorized personnel may result in fire hazard or electric shock.**

**Ask the nearest branch, business office or a dealer for inspection and repair.**



**Turn off the main power before maintenance work. Otherwise, an electric shock may result.**



**Turn off the main power before cleaning the equipment. Especially, make sure to turn off the indicator if a rectifier is used. Otherwise, equipment failure, or death or serious injury due to electric shock may result, because voltage is outputted from the rectifier even when the radar is not operating.**

For operating the radar equipment in the good conditions, it is necessary to make the maintenance work as described below. If maintenance is made properly, troubles will reduce. It is recommended to make regular maintenance work.

Common points of maintenance for each unit are as follow:

Clean the equipment.

Remove the dust, dirt, and sea water rest on the equipment cabinet with a piece of dry cloth. Especially, clean the air vents with a brush for good ventilation.

## 8.2 MAINTENANCE ON EACH UNIT

### 8.2.1 Scanner Unit NKE-1130/2103/2254



## WARNING



**Turn off the main power source before starting maintenance.**

**Otherwise, an electric shock or injury may be caused.**



**Turn "OFF" the safety switch to stop the scanner unit. (Refer to pages 1-6 to 1-10.)**

**Otherwise, you may be injured if touching the rotating scanner unit by accident.**



**Do not touch the radiator. Even if the power is turned off, the radiator may be rotated by the wind.**

After the work, turn "ON" the scanner unit safety switch.

## Precautions in Mounting the Cover

When the cover is removed for regular checkup and replacement of parts and refitted after such work, the procedures of fastening bolts shall be taken with the following precautions:

- The proper fastening torque of the fitting bolts (M8) is 1176 to 1470 N•cm (120 to 150kgf•cm) (which makes the inside water-tight and protects the packings against permanent compressive strain).  
The packings start producing from the cover at a torque of approximately 1470N•cm (150kgf•cm).  
Do not fasten the bolts with a torque exceeding the specified value. Otherwise, the screws may be broken.
- Use an offset wrench of 11 mm × 13 mm or a double-ended wrench of 13 mm × 17 mm (not longer than 200 mm).
- Screw all the bolts by hand first to prevent them playing, then fasten them evenly in order not to cause one-sided fastening. (Fasten the bolts with 25% of the required torque at the first step.)

\*: Fasten the bolts in the diagonal order.

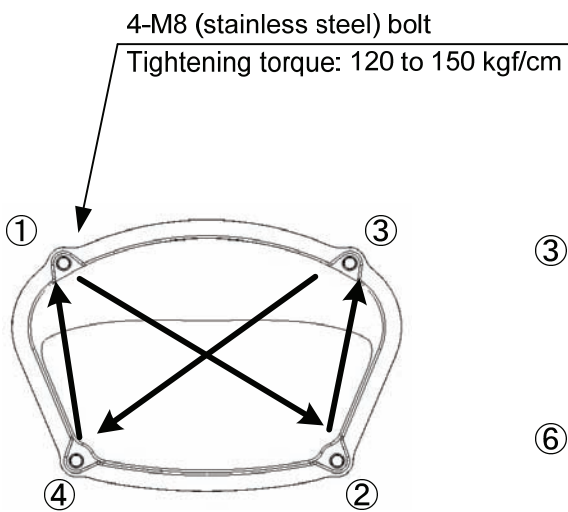

Bolt Tightening Procedure of  
NKE-1125/2254 Cover

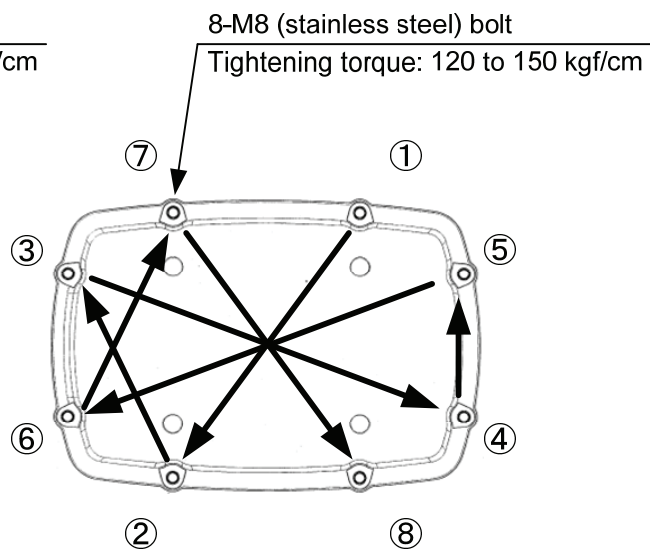

Bolt Tightening Procedure of  
NKE-1130 Cover

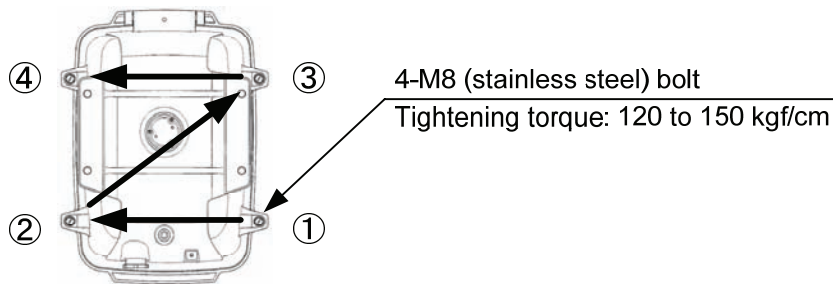

Bolt Tightening Procedure of  
NKE-2103 Cover

## (1) Radiator

### Attention

- **If the radiator front face (radiation plane) is soiled with smoke, salt, dust, paint or birds' droppings, wipe it with a piece of soft cloth wetted with alcohol or water and try to keep it clean at all times. Otherwise, radar beam radiation may attenuate or reflect on it, resulting in deterioration of radar performance.**
- **Never use solvents of gasoline, benzine, trichloroethylene and ketone for cleaning.**

Check up and clean the radiator.

## (2) Rotating section

- (a) **Supply Oil Seal**  
An scanner unit with a grease nipple needs grease supply. Remove the cap of the grease nipple on the front of the radiator support, and supply grease with a grease gun.  
Make the oiling every six months. The oil quantity shall be approximately 100 g, which is as much as the grease comes out of the oil seal. Use the grease of Mobilux 2 of Mobil Oil.
- (b) **Oiling gears**  
Apply grease evenly to the tooth surfaces of the main shaft drive gear and the encoder drive gear with a spreader or brush. Oiling in short intervals is more effective to prevent the gears from wear and tear and extend their service life, but oil at least every six months.  
Use Mobilux2 of Mobile Oil.
- (c) **Mounting legs**  
Check the mounting legs and mounting bolts of the scanner unit case for corrosion at intervals and maintain them to prevent danger. Apply paint to them once a half year because painting is the best measure against corrosion.

---

## 8.2.2 Display Unit NCD-4530



# WARNING



**When cleaning the screen, do not wipe it too strongly with a dry cloth. Also, do not use gasoline or thinner to clean the screen. Otherwise the screen surface may be damaged.**

Dust accumulated on the screen will reduce clarity and darken the video. For cleaning it, wipe it with a piece of soft cloth (flannel or cotton). Do not wipe it strongly with a piece of dry cloth nor use gasoline or thinner.



# 8.3 PERFORMANCE CHECK

Make operational check on the radar equipment regularly and if any problem is found, investigate it immediately. Pay special attention to the high voltage sections in checking and take full care that no trouble is caused by any error or carelessness in measurement. Take note of the results of checking, which can be used effectively in the next check work.

Operational check shall be made in accordance with Table 8-1 Function Check List in the order as specified in it.

**Table 8-1 Check List**

Equipment	Item to be checked	Criteria	Remarks
Transmitter-receiver Unit	Tuning LED of Receiver	The LED is lighting during operation	48NM range
Display Unit	Video and echoes on the screen Sensitivity LCD brilliance can be controlled correctly Various markers Various numerical indications Lighting	Can be correctly controlled	
	Memory	See section 8.3.1 [I]-[1].	
	Communications Lines	See section 8.3.1 [I]-[3].	
	Power Supply, Backup Battery	See section 8.3.1 [I]-[4].	
	Monitor	See section 8.3.1 [II].	
	Operation Unit	See section 8.3.1 [III].	
	System Alarm Log Display	See section 8.3.1 [V].	
	System Information Display	See section 8.3.1 [VI].	
	Magnetron current	See section 8.3.1 [VII].	
	Target Tracking	See section 5.2.7.	
Scanner Unit	Signals from the Scanner Unit	See section 8.3.1 [I]-[2].	
	Performance Monitor	See section 8.3.1 [IV].	

---

## 8.3.1 Check Performance on Test Menu

The radar operating state can be checked by opening the Test Menu.

### Procedures

1. Perform the following menu open procedure to open the Test Menu.

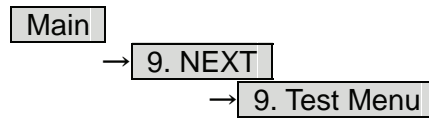

2. Select the items to be checked.

The list of check items will appear.

1. Self Test	[I] Self-diagnostic function
2. Monitor Test	[II] Monitor check
3. Keyboard Test	[III] Operation unit check
4. MON Display	[IV] Performance monitor
5. System Alarm Log	[V] Error log display
6. System Information	[VI] System information display
Magnetron Current	[VII] Indication of magnetron current

3. Select the items to be checked.

The list of check items will appear.

### [I] Self-diagnosis function (Self Test)

Check of memory, scanner unit, and communications Lines

1. Memory Test	[1] Memory check
2. TXRX Test	[2] Scanner check
3. Line Test	[3] Communication line check
4. Supply Voltage	[4] Supply voltage check

### [1] Memory Test

Checks for the performance of built-in memory.

1. SDRAM	[1] SDRAM check
2. SRAM	[2] SRAM check
3. FLASH ROM	[3] Flash ROM check
4. GRAPHIC	[4] Graphic check

When no abnormality is found, OK is displayed.

When an abnormality is found, NG is displayed.

**[2] TXRX Test**

Checks for signals from the scanner.

Safety Switch	Scanner's safety switch check
AZI Pulse	Scanner rotation signal check
HL Pulse	Heading line signal check
MH Current	Check on the load current of high voltage in the modulator
Trigger	Radar trigger signal check
Video	Radar video check

When no abnormality is found, OK is displayed.

When an abnormality is found, NG is displayed.

In standby, \*\* will appear.

**[3] Check of Communication Lines (Line Test)**

Check the status of communications with options.

TXRX	Check on connection with the transmitter-receiver
SIG.PROC	Check on connection with the signal processing circuit
TT	Check on connection with the target tracking unit
GYROO I/F	Check on connection with the GYRO I/F unit
GPS Compass	Check on connection with the GPS compass
ISW	Check on connection with the interswitch
Plotter Key	Check on connection with the plotter option

When no abnormality is found, OK is displayed.

When an abnormality is found, NG is displayed.

The status display field of equipment not connected is left blank.

**[4] Supply Voltage**

Check the voltage of internal power supply.

Item	Normal value
12V	11.00 to 12.20V
5V	4.75 to 5.25V
3.3V	3.14 to 3.46V
Battery	2.50V or more

---

### **[III] Monitor Test**

Checks for the display.

The test pattern will be shown on the display.

Pattern 1	All colors are filled with white.
Pattern 2	A white box is displayed on the black background of 1280 × 1024 dots.
Pattern 3	Displays rectangle × 2, circle × 2, and cross-shape × 13 (white lines on the black background).
Pattern 4	Displays “H” of 9 dots × 9 dots on the entire screen (white character on the black background).
Pattern 5	Gray scale display (16 levels)
Pattern 6	Displays a color bar.
Pattern 7	Displays the VDR test pattern.
Pattern 8	Displays the specified color.

To return to the normal display, press any key.

If errors occur in the monitor, no test pattern will appear.

### **[IIII] Keyboard Test (Operation Unit Test)**

Checks for the controls and switches of the operation panel.

1. Key Test	[1] Key check
2. Buzzer Test	[2] Buzzer check
3. Light	[3] Control panel light check

#### **[1] Key Test**

Checks for the controls and switches of the operation panel.

Each key on the operation panel on the display is shown in reverse video at the same time the key is pressed, and the name of the pressed key is displayed.

#### **[2] Buzzer Test**

Checks for the operation panel buzzer.

The buzzer will sound.

The buzzer automatically stops after it sounds for a specified length of time.

#### **[3] Light Test**

Checks for the control panel light.

The brightness of the operation panel is gradually intensified at four levels.

### **[IV] Check of the Performance Monitor (MON Display)**

Displays the performance monitor status.

* Transmitter System	Transmitter system attenuation value check.
Attenuation Value	
* Receiver System	Receiver system attenuation value check.
MON Pattern Range	
Attenuation Value	

Turn the [VRM] dial to make adjustments so that the farthest point of the performance monitor pattern. The attenuation value of receiver system is displayed.

**[V] System Alarm Log display**

Displays previously occurred system errors with the dates and times when they occurred.  
The current error is displayed at the lower right of the radar display. For details, refer to Chapter 9.



The Error log display button (2-29P Alarm) is clicked, in the same way as that one.  
To erase the alarm logs, press the **All Clear** button in the log display window.

**[VI] System INFO**

Displays the current system information.

Indicator
TXRX
System No.
TX Time

X-Band
S-Band
Motor Time
TXRX Total Time

Total Time
------------

Processor software version information  
Scanner software version information  
System number  
Total magnetron transmitting time (Total time during which radar was transmitted)

Total operating time (Total power-on time)  
Total operating time of the scanner unit (Total power-on time of the antenna unit)  
Total operating time of the display unit (Total power-on time of the display unit)

**[VII] Magnetron Current**

Displays the Magnetron Current bar indicating the magnetron current to check.  
When a 48 NM range is set, the magnetron current is normal if the Magnetron Current bar reads the value below.

10 kW: 4 to 7 scale marks  
25/30 kW: 5 to 8 scale marks

---

## **8.4** REPLACEMENT OF MAJOR PARTS

The system includes parts that need periodic replacement. The parts should be replaced as scheduled. Use of parts over their service life can cause a system failure.

### CAUTION



**Turn off the main power source before replacing parts. Otherwise, an electric shock or trouble may be caused.**



**Before replacing the magnetron, turn off the main power source and wait for 5 minutes or more until the high voltage circuits are discharged. Otherwise, an electric shock may be caused.**



**Take off your wrist watch when bringing your hands close to the magnetron. Otherwise, your watch may be damaged because the magnetron is a strong magnet.**



**Two or more persons shall replace the liquid crystal monitor. If only one person does this work, he may drop the LCD, resulting in injury.**



**Even after the main power source is turned off, some high voltages remain for a while. Do not contact the inverter circuit in the LCD with bare hands. Otherwise, an electric shock may be caused.**

### 8.4.1 Parts Required for Periodic Replacement

Here are parts required for periodic replacement

Part name	Interval	Radar model	Part type	Part code
1. Magnetron	4000 hours	JMA-5312-6/6HS	MAF1565N	5VHAA00102
		JMA-5322-7/9/6HS	M1568BS	5VMAA00106
		JMA-5332-12	M1555	5VMAA00104
2. Motor	10000 hours	JMA-5312-6/6HS	7BDRD0048	7BDRD0048
		JMA-5322-7/9	7BDRD0044A	7BDRD0044A
		JMA-5322-6HS	7BDRD0045A	7BDRD0045A
		JMA-5332-12	MDBW10823	MDBW10823
3. Fan (Scanner Unit)	20000 hours		7BFRD0002	7BFRD0002
4. LCD PANEL	50000 hours		CML-771	CML-771
5. Monitor fan	20000 hours		CBP-173A	CBP-173A
6. Fan (Radar Process Unit)	20000 hours		7BFRD0005	7BFRD0005
7. Backup battery	5 years		5ZBCJ00012	5ZBCJ00012

### 8.4.2 Replacement of Magnetron

**Caution:** Replacement of magnetron must be made by specialized service personnel. For details, refer to Service Manual.

When mounting a new magnetron, do not touch the magnet with a screwdriver or put it on an iron plate. After replacement, connect the lead wire correctly.

#### Handling of Magnetron under Long-Time Storage

The magnetron that has been kept in storage for a long time may cause sparks and operate unstably when its operation is started. Perform the aging in the following procedures:

- (1) Warm up the cathode for a longer time than usually. (20 to 30 minutes in the STBY state.)
- (2) Start the operation from the short pulse range and shift it gradually to the longer pulse ranges. If the operation becomes unstable during this process, return it to the standby mode immediately. Keep the state for 5 to 10 minutes until the operation is restarted.

---

## Magnetron Replacement Procedure for Scanner Unit NKE-1130

- (1) Before starting part replacement work, turn off the safety switch of the scanner unit.

The safety switch is located on the rear (stern) side. Remove the cover and turn off (to the lower side) the safety switch.

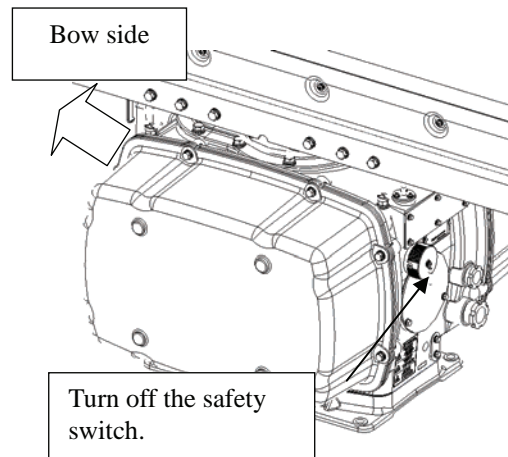

- (2) Loosen the hexagonal bolts and remove the cover on the left (port) side

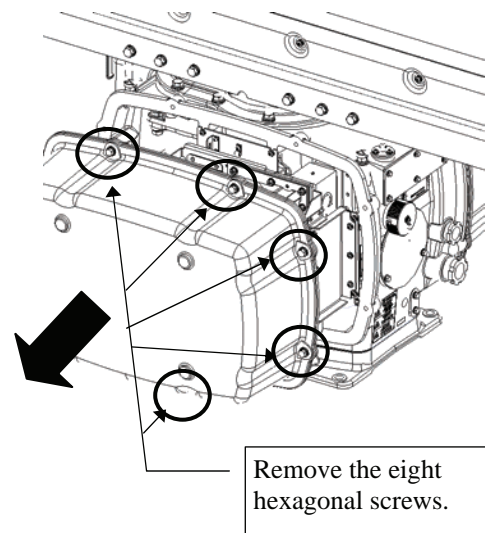

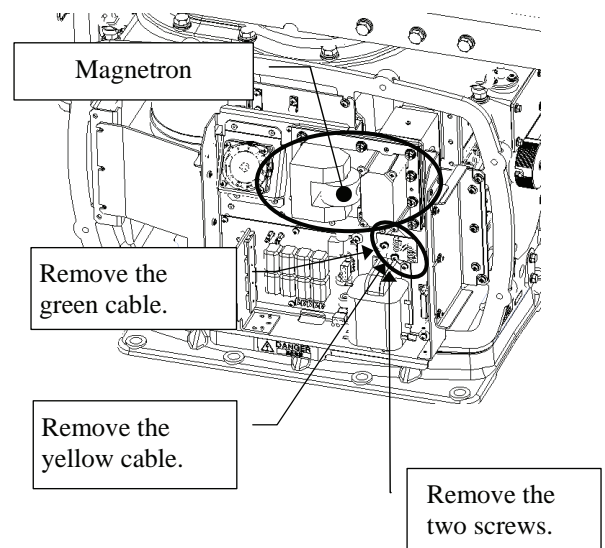

- (3) Check that there is no remaining electric charge in the modulation high-voltage circuit board. Remove the two screws (M4) holding the magnetron cables (both yellow and green).





- (4) Remove the eight screws (M6) to remove the fixture holding the magnetron. The screws cannot be removed from the fixture, so loosen the all eight screws and remove the magnetron together with the fixture.

 The magnetron is held by a hook, but be careful not to let it fall.

 Use a shielded screwdriver. If the magnetron comes into contact with any metal (tool), its performance may deteriorate.

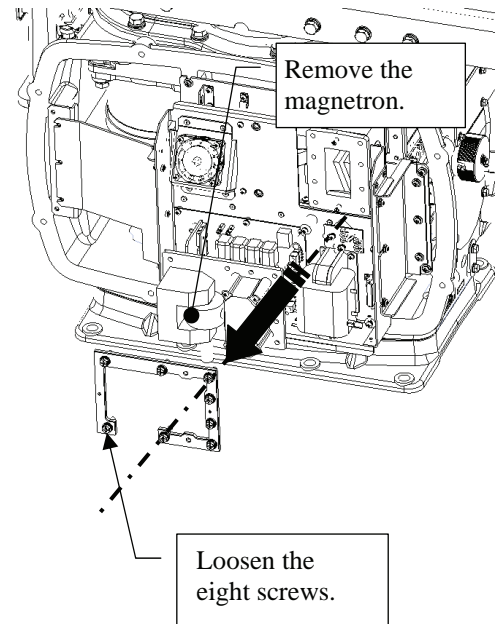

- (5) Install the new magnetron together with the fixture and tighten the screws to hold the cables. Follow the removal procedure in the reverse order. Do not forget to tighten the screws and connect the cables.

---

## Magnetron Replacement Procedure for Scanner Unit NKE-2254

- (1) Before beginning work, turn off the safety switch located on the bottom of the stern side of the scanner unit.

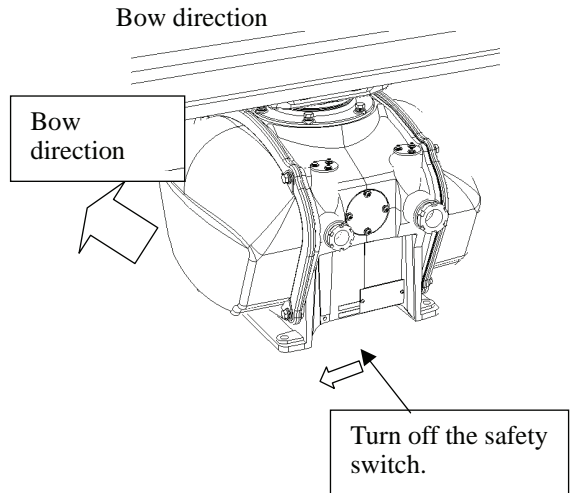

- (2) Loosen the hexagonal bolts and remove the cover on the right (starboard) side.

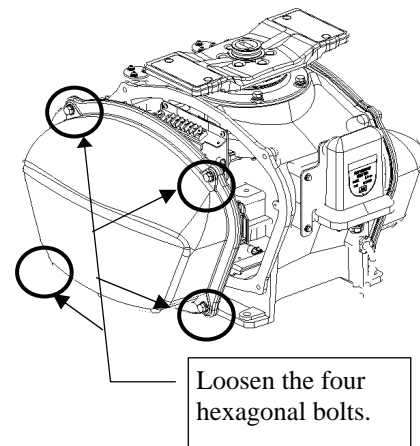

- (3) Loosen the screws (four M4 screws) to remove the magnetron cover.

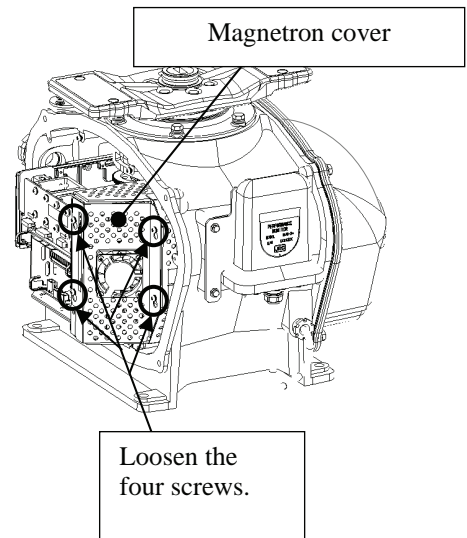

- (4) Make sure there is no charge remaining in the modulation high-voltage circuit board, and then remove the screws (two M4 screws) holding the magnetron cables (yellow and green) in place.
- (5) Remove the screws (four M4 screws) holding the magnetron in place, then replace the magnetron after cutting the leads (yellow and green) for the replacement magnetron to an appropriate length.

 Use a shielded screwdriver because the contact of the metal tool with the magnetron causes deterioration of its performance.

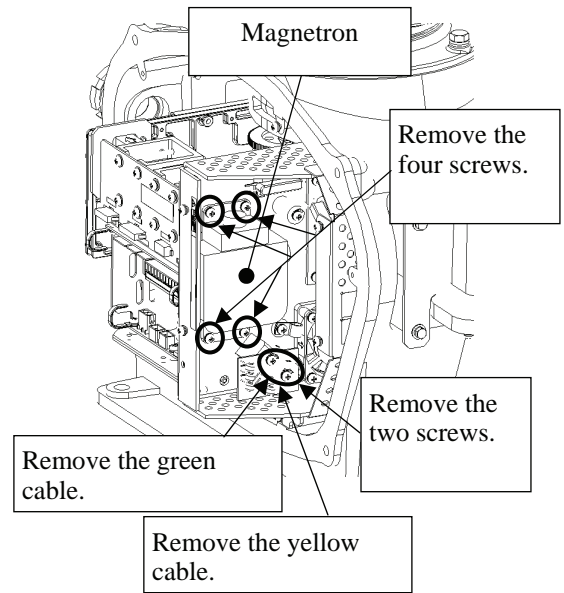

- (6) After having replaced the magnetron, reassemble the unit by following the disassembly procedure in the reverse order.  
Do not forget to tighten the bolts and screws, and do not forget to reconnect the cables.

 Extreme care should be taken to connect the leads (yellow and green) to the magnetron for prevention of contact with other parts or the casing. Contact may cause them to discharge.

---

## Magnetron Replacement Procedure for Scanner Unit NKE-2103

- (1) Before beginning work, turn off the safety switch on the bottom of the scanner unit.

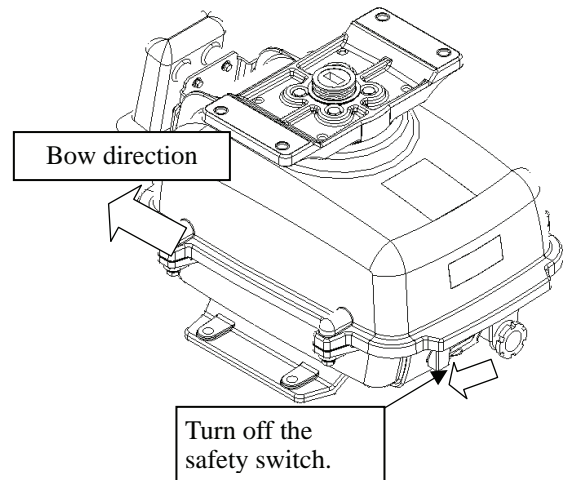

- (2) Loosen the hexagonal bolts (four bolts) and open the upper cover until the stopper of the stay operates.

 When closing the upper cover, release the stay stopper and then tighten the cover.

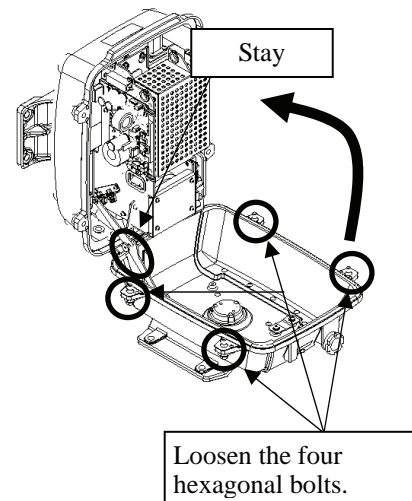

- (3) Loosen the screws (four M4 screws), remove the transmitter-receiver unit cover, and remove the cables connected to the transmitter-receiver unit (ten cables). Slide the cover of the transmitter-receiver unit to remove it.

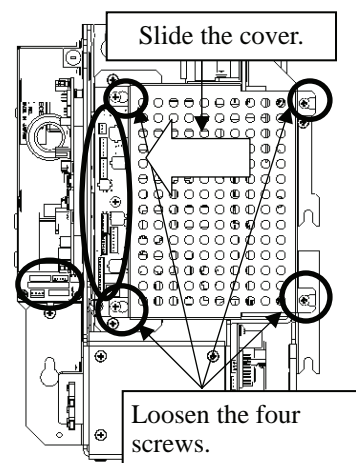

- (4) Loosen the bolts (five M5 bolts) and remove the transmitter-receiver unit. Slide the transmitter-receiver unit upward to remove it.

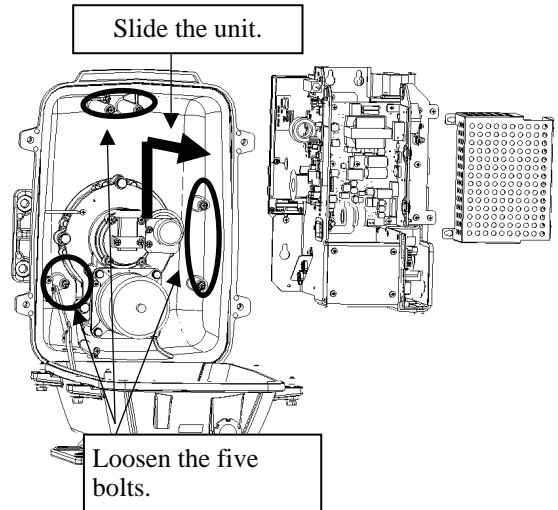

- (5) Remove the screws (six M4 screws) holding the magnetron in place and replace the magnetron.



Use a shielded screwdriver because the contact of the metal tool with the magnetron causes deterioration of its performance.

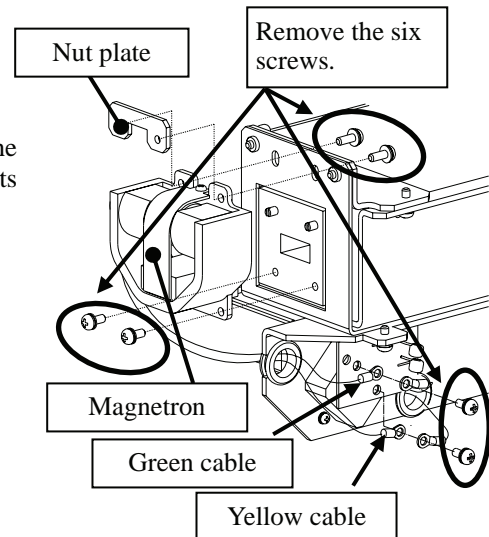

- (6) Cut the leads (yellow and green) for the replacement magnetron to an appropriate length, then tighten the screws and fix the cables in place.  
After having replaced the magnetron, reassemble the unit by following the disassembly procedure in the reverse order.  
Do not forget to tighten the bolts and screws, and do not forget to reconnect the cables.



Extreme care should be taken to connect the leads (yellow and green) to the magnetron for prevention of contact with other parts or the casing. Contact may cause them to discharge.

### 8.4.3 Replacement of Motor

**Caution:** Replacement of motor must be made by specialized service personnel.  
For details, refer to Service Manual.

#### Motor Replacement Procedure for Scanner Unit NKE-1130

- (1) Before starting part replacement work, turn off the safety switch of the scanner unit.

The safety switch is located on the rear (stern) side. Remove the cover and turn off (to the lower side) the safety switch.

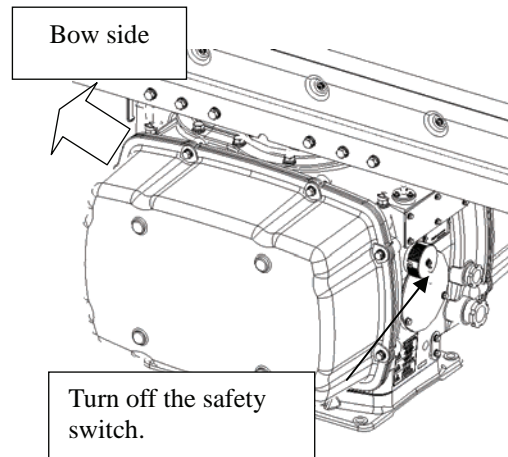

- (2) Loosen the hexagonal bolts and remove the cover on the both sides

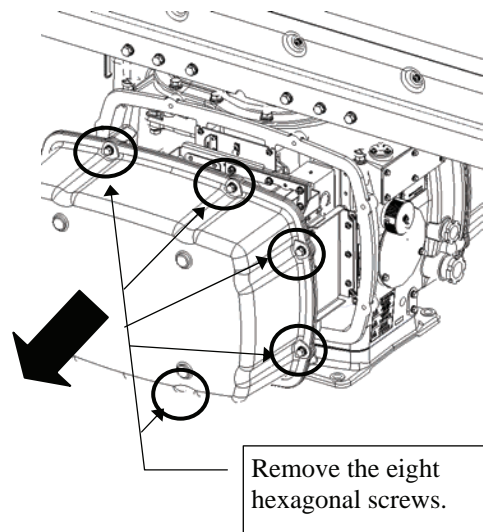

- (3) Remove the cover on the right (starboard) side and loosen the four screws (M4) to remove the driver unit, which has the motor driver circuit board on its back side.  
Disconnect the cables connecting the motor to the motor driver circuit board.

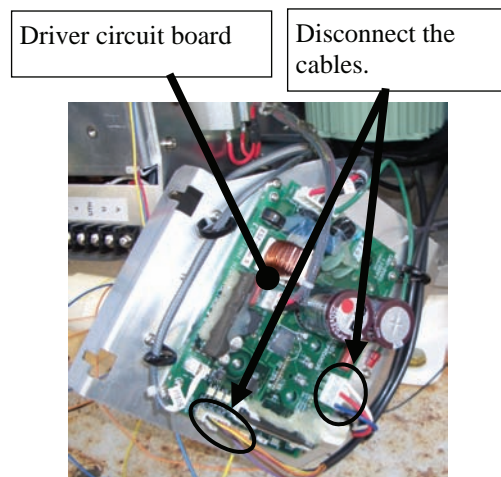

- (4) Remove the cover on the left (port) side and remove the five screws (M5) to remove the fixture.

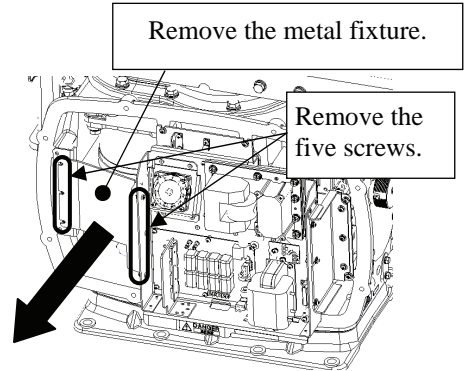

- (5) Remove the four hexagonal screws (M10x40, SW10, and W10) that hold the motor from both the right and left sides to remove the motor.

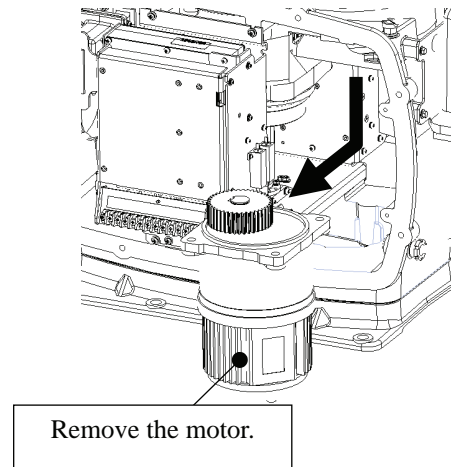
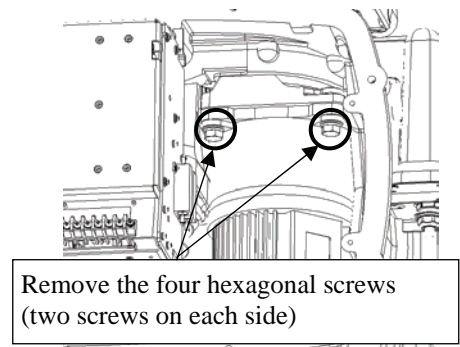

- (6) Apply grease to the gear wheel of the new motor.

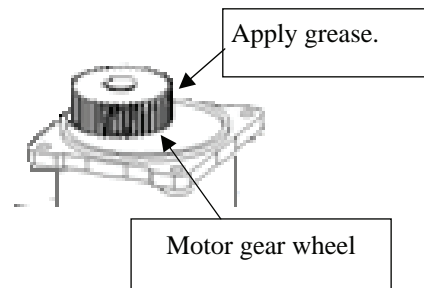

- (7) Install the new motor in the scanner unit and secure it using the hexagonal screws. Tighten the screws with the specified torque (380 kgf-cm).
- (8) After replacing the motor, assemble the unit in the reverse order of the disassembly procedure. Do not forget to tighten the screws and connect the cables.

---

## Motor Replacement Procedure for Scanner Unit NKE-2254

- (1) Before beginning work, turn off the safety switch located on the bottom of the stern side of the scanner unit.

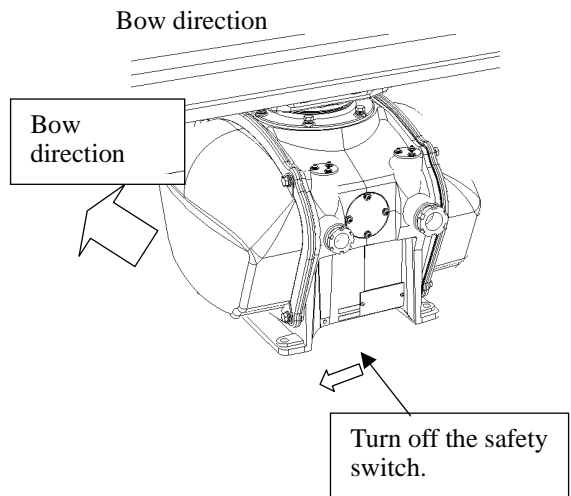

- (2) Loosen the hexagonal bolts and remove the cover on the **left** (port) side.

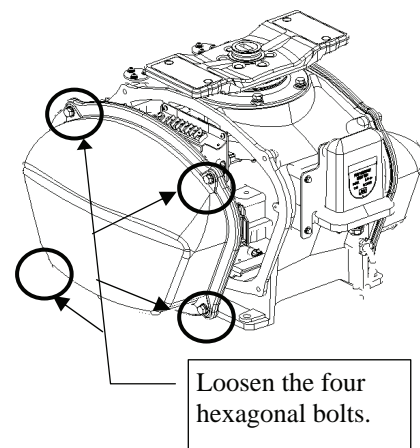

- (3) Remove the cables connected to the motor driver circuit board.
- (4) Remove the hexagonal bolts (four M8 bolts) and remove the motor.

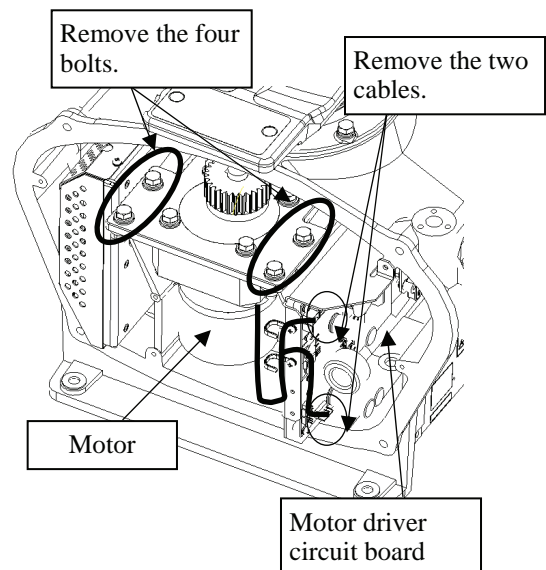



(5) Remove the hexagonal bolts (four M8 bolts) and remove the installation plate from the motor.

(6) Attach the installation plate to the replacement motor. Do not forget to tighten the hexagonal bolts to an appropriate torque (210 kgf-cm) so they are free of looseness.

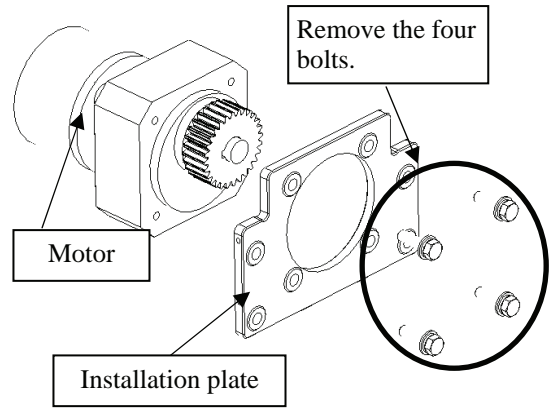

(7) Install the motor into the scanner unit. Press the motor against the protrusions of the arm fixed to the motor on which the arm extends through the wall of the casing, adjust it to minimize backlash, and fix it in place. Do not forget to tighten the hexagonal bolts, to an appropriate torque (140 kgf-cm) so they are free of looseness.

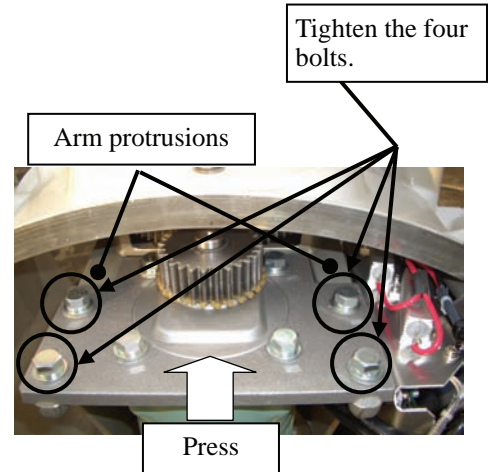

(8) After having installed the motor, grease the gear wheel.

(9) After having replaced the motor, reassemble the unit by following the disassembly procedure in the reverse order. Do not forget to tighten the bolts and screws, and do not forget to reconnect the cables.

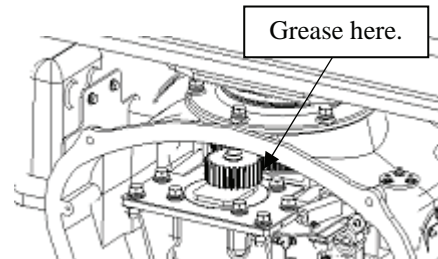

---

## Motor Replacement Procedure for Scanner Unit NKE-2103

- (1) Before beginning work, turn off the safety switch on the bottom of the scanner unit.

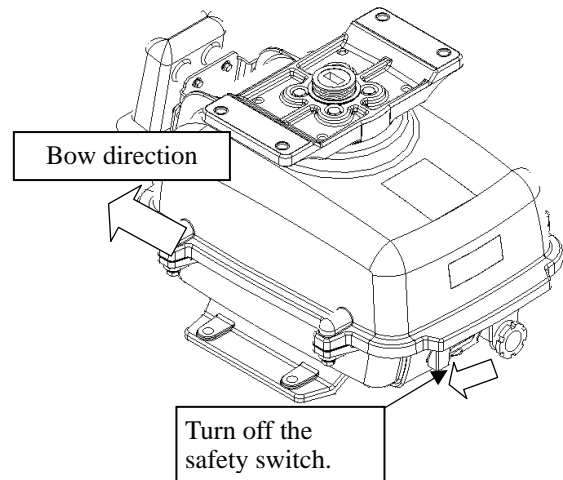

- (2) Loosen the hexagonal bolts (four bolts) and open the upper cover until the stopper of the stay operates.

 When closing the upper cover, release the stay stopper and then tighten the cover.

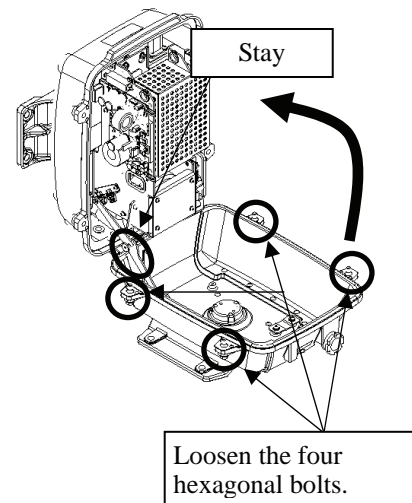

- (3) Loosen the screws (four M4 screws), remove the transmitter-receiver unit cover, and remove the cables connected to the transmitter-receiver unit (ten cables). Slide the cover of the transmitter-receiver unit to remove it.

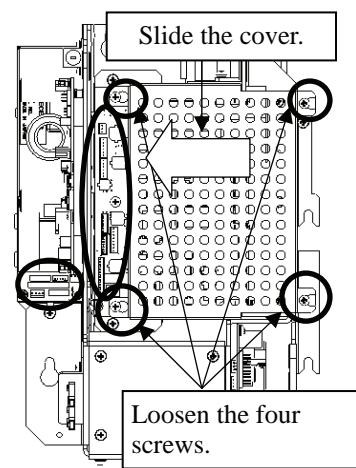

- (4) Loosen the bolts (five M5 bolts) and remove the transmitter-receiver unit. Slide the transmitter-receiver unit upward to remove it.

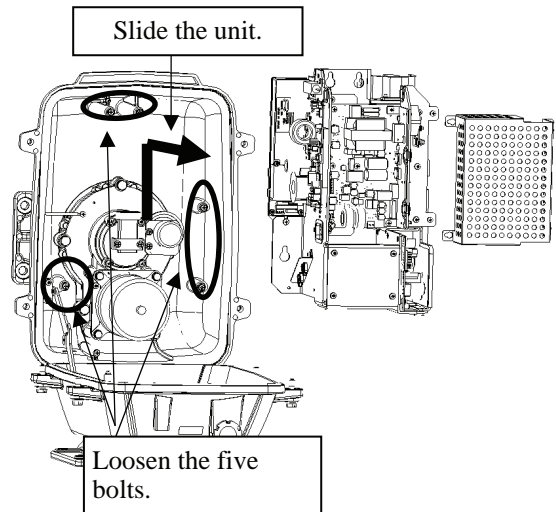

- (5) Remove the hexagonal bolts (four M6 bolts) and remove the motor. Grease the gear wheel of the replacement motor and place it in the casing. Do not forget to tighten the hexagonal bolts to an appropriate torque (72 kgf-cm) so they are free of loose

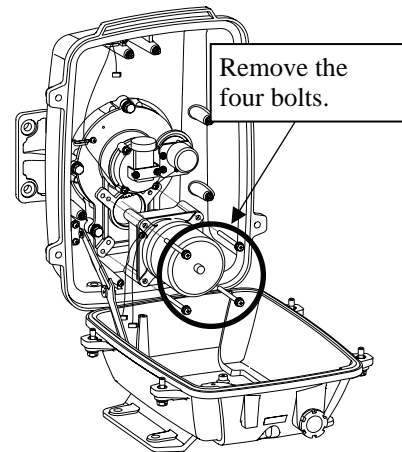

- (6) After having replaced the motor, reassemble the unit by following the disassembly procedure in the reverse order.

 Do not forget to tighten the bolts and screws, and do not forget to reconnect the cables. Clamp the cables so they do not interfere with the rotation of the motor's rotors.

---

## 8.4.4 Replacement of LCD Monitor

**Caution:** Replacement of LCL Monitor must be made by specialized service personnel.  
For details, refer to Service Manual.

### Attention

- **When replacing the LCD monitor, which is easily broken by a little impact, handle it carefully and do not hit any article against it or put it on a hard article.**

- (1) Disconnect the cables from the connectors "VIDEO" and "VIDEO DC OUT" on the rear of the processor.
- (2) Softly place the LCD monitor on a desk covered with a soft cloth.
- (3) Attach a new LCD monitor in the reverse sequence as described above.

## 8.4.5 Replacement of Backup Battery

**Caution:** Replacement of backup battery must be made by specialized service personnel.  
For details, refer to Service Manual.

A coin-cell battery maintains radar system configuration, date, and time information while power off condition. radar system configuration is saving to non-volatile memory at fixed intervals.

### About the Battery Alarm

If **Battery Low** is appeared at the lower-right of the display when start up the radar system, the battery has not enough time left to live. We recommend to replace the battery.

If **Battery Dead** is appeared at the lower-right of the display when start up the radar system, the battery has no time left to live. There is a necessary to replace the battery. In This condition, this radar system is restored configuration information from flash memory and normal operation is available. However, you turned of the radar system before saving to flash memory, the configuration information is maybe lost. In this case, you must setup the configuration again.

If **No Battery** is appeared at the lower-right of the display when start up the radar system, the battery has not inserted. There is a necessary to insert the battery.

**Note:** About disposal of used battery, refer to Section 10.2.

### How to Replacement of Backup Battery

#### 1. Remove the Coin-Cell Battery from the Holder

Be careful, don't break holder.

#### 3. Fix the Coin-Cell Battery in the Holder

Turn up + surface.  
Battery type : CR2032



# SECTION 9 TROUBLESHOOTING AND AFTER-SALES SERVICE

9.1	FAULT FINDING .....	9-1
9.2	TROUBLE SHOOTING.....	9-6
9.3	AFTER-SALES SERVICE .....	9-11

# 9.1 FAULT FINDING

In case of semiconductor circuits, it is deemed that there are few cases in which the used semiconductor devices have inferior quality or performance deterioration except due to insufficient design or inspection or by other external and artificial causes. In general, the relatively many causes are disconnection in a high-value resistor due to moisture, a defective variable resistor and poor contact of a switch or relay.

Some troubles are caused by defective parts, imperfect adjustment (such as tuning adjustment) or insufficient service (such as poor cable contact). It will also be effective to check and readjust these points.

## 9.1.1 List of Alarms and other Indications

The system automatically recognizes an internal alarm and displays the alarm message. If an event which is not trouble but must be reported to the operator occurs, the system notifies the operator of the event.

This section gives the list of alarms displayed by the system and other display lists.

ALR No : Unique alarm number in ALR sentence and ACK sentence.

**Table 9-1 List of System Error Message**

Message	Description	ALR No.
TXRX (SSW Off)	Scanner: Safety switch OFF.	308
TXRX (AZI)	Scanner: BP error.	311
TXRX (HL)	Scanner: HL error.	312
TXRX (MHV)	Scanner: Modulator's high voltage alarm.	315
TXRX (Data)	Scanner: No communication, communication mismatched, checksum error, or collision.	326
TXRX (Heater)	Scanner: Magnetron heater voltage error.	314
TXRX (Reverse)	Scanner: Reverse rotation.	313
TXRX (Video)	Scanner: VIDEO error.	309
TXRX (Trigger)	Scanner: TRIGGER error..	310
TXRX (Fan 1)	Scanner: FAN 1 error.	317
TXRX (Fan 2)	Scanner: FAN 2 error.	317
Keyboard (Data)	Operation unit: Communication error or checksum error.	325
Keyboard2 (Data)	Second operation unit: Communication error or checksum error.	325
GYRO I/F (Data)	GYRO I/F: No communication or checksum error.	324
GYRO I/F (GYRO)	GYRO I/F: GYRO error (error bit detected).	110
GYRO I/F (Log)	GYRO I/F: Log error (error bit detected).	111
GPS (Status)	GPS status error.	103
Position (Data)	Latitude / longitude data: No communication or data error.	102
Date (Data)	Date data: No communication or data error.	112
Speed (Log)	1-axis log: No communication or data error.	114
Speed (2AXW)	2-axis log (speed over water): No communication or data error.	114
Speed (2AXG)	2-axis log (speed over ground): No communication or data error.	114
Speed (GPS)	GPS speed: No communication or data error.	114
PROC (Interrupt)	Process unit: Interrupt error.	962
PROC (AZI)	Process unit: AZI error.	305





PROC (HL)	Process unit: HL error.	306
ASIC1 to RADAR	Error during interrupt from ASIC1 to RADAR DSP.	963
PROC (Video)	VIDEO error.	303
PROC (Trigger)	Trigger error.	304
Heading (Data)	Heading data: No communication or data error.	113
Depth (Data)	Water depth: No communication or data error.	115
TEMP (Data)	Water temperature: No communication or data error.	117
Wind (Data)	Wind direction/velocity: No communication or data error.	118
Current (Data)	Tidal current: No communication or data error.	119
ROT (Data)	Rate of Turn: No communication or data error.	120
RSA (Data)	Rudder Sensor Angle: No communication or data error.	121
Autopilot (Data)	APB: No communication or data error.	101
Fan (LCD)	LCD monitor: Fan error.	955

**Table 9-2 List of Notification**

Message	Description	ALR No.
CCRP Changed	CCRP is automatic changed.	
Weather INFO	Weather information is received.	
Copying	Display is capturing to file.	
Set GYRO	Requires setting of true bearing.	
TM Reset	Use care of resetting TM.	
POSN Reset	Change the latitude and longitude sentence.	

**Table 9-3 List of Target Tracking Alarms and AIS Function Critical Alarms**

Message	Description	ALR No.
CPA/TCPA	There is a dangerous target.	301

**Table 9-4 List of RADAR Alarm, Target Tracking Alarms and AIS Function Alarms**

Message	Description	ALR No.
CPA/TCPA	There is a dangerous target.	301
RADAR Alarm (In)	Targets have entered the radar alarm range.	
RADAR Alarm (Out)	Targets have left the radar alarm range.	
CPA/TCPA	There is a dangerous target.	301
Trial	There is a dangerous target, when trial maneuver is active.	
New Target	Acquisition or activation of a target in the automatic acquisition / activation zone.	335
Lost	Failure in tracking the target that has been under tracking. Failure in receiving AIS target data for a specified time.	
REF Target	Decrease in the reference target accuracy.	
MAX Target	The maximum number of targets is under acquisition.	
95% Capacity	Over 95% of the maximum number of targets to be tracked.	
AIS Max Target	Maximum number of AIS targets.	333
AIS 95% Capacity	Over 95% of the maximum number of AIS targets.	
AIS ACT MAX	Maximum number of AIS targets to be activated.	

AIS ACT 95% Capacity	Over 95% of the maximum number of AIS targets to be activated.	
TT (Boot)	Target tracking unit start failure.	323
TT (Data)	The target tracking unit is malfunctioning..	323
AIS (Data)	AIS: No communication or communication error.	116
AIS PROC (Data)	AIS processing circuit: No communication or communication error.	328
AIS ALARM ***	AIS alarm (Up to 10 alarm messages can be displayed.).	

**Table 9-5 List of Route Error Messages and Warnings**

Message	Description	ALR No.
Arrival	Arrive at way point.	
Break Off (WPT)	Out of the way point.	
Approach	Approach the route.	
Cross Track Error	Go off the route.	

**Table 9-6 List of Operational Error Messages and Warnings**

Message	Description	ALR No.
No Position Data	Mark or line input when the latitude and longitude is invalid.	
No Heading Data	Target tracking operation or TM selection when bearing data is invalid.	
Out of Range	Out of target acquisition range.	
Invalid Range	TM selection due to TM-disabled range (96 nm). Zooming in a ZOOM-disabled range (0.125 nm).	
MAX Point	Tried to enter navigation information beyond the specified.	
Can't Transmit	Tried to transmit within 5 second after standby or when the transmitter-receiver has any trouble.	
Invalid Data	Tried to enter any data beyond its range.	
Invalid Connection	The operator set performance monitor to on without selecting straight.	
No Card	Card not detected yet.	
Card Full	Card capacity insufficient.	
Format Card	Unformatted card.	
Invalid Card	Invalid card.	
Read Failed	Read failure.	
Write Failed	Write failure.	
Delete failed	Deletion failure.	
Format Failed	Format failure.	
Copy Failed	Copy failure.	
Not Allowed	General operation error.	
No Object	No object at the cursor-specified position.	
Slave Mode	Operation of a menu for the scanner unit when the slave mode is active.	

**Table 9-7 List of Conditions Messages**

Message	Description	ALR No.
GPS (HDOP)	The HDOP level is increased (Decrease in the GPS accuracy.).	
MON Test	Performance monitor is active.	
Scanner Rotating	The scanner is rotating (When transmitter is standby state.).	
Battery Low	The battery is weakening.	
Battery Dead	The battery is dead.	
No Battery	The battery had removed.	

**Table 9-8 List of Interswitch Alarms and Messages**

Message	Description	ALR No.
Master Range CHG	The range of the own display unit has changed due to change in the range of the master display unit.	
ISW Complete	The switchover of the Interswitch ended normally.	
ISW Busy	Access to the ISW menu was made during interswitching.	
TXRX Standby	The scanner unit is in the standby mode.	
ISW Straight	Failed in straight connection when the Interswitch system stops operating.	
ISW Standby	The Interswitch recovered normally.	
ISW Time Out	Failed in switching.	
ISW Error	The interswitch is disabled.	
Pattern CHG Failed	Connection change failed.	
Connection Masked	Inhibition of control / connection is set.	
Master Standby	The master display unit does not transmit any signals.	
ISW (Data)	ISW: No communication, data mismatched, or checksum error.	327
Update ISW Software	Tried to enter new TXRX function, when interswitch software used old version.	

### **Message set off in a failure of the monitor fan**



When a failure has occurred in the monitor fan, the LCD monitor displays **LCD FAN FAILURE** at the center. This display will disappear by pressing the BRIGHTNESS knob on the LCD monitor. In order to replace the monitor fan, contact our service department, or the distributor.

## 9.1.2 Operation Checking

When the system is operating, the operation status (located at the upper right of the screen) is changing pictures.

If picture freeze occurred, turn off the system and restart the system.

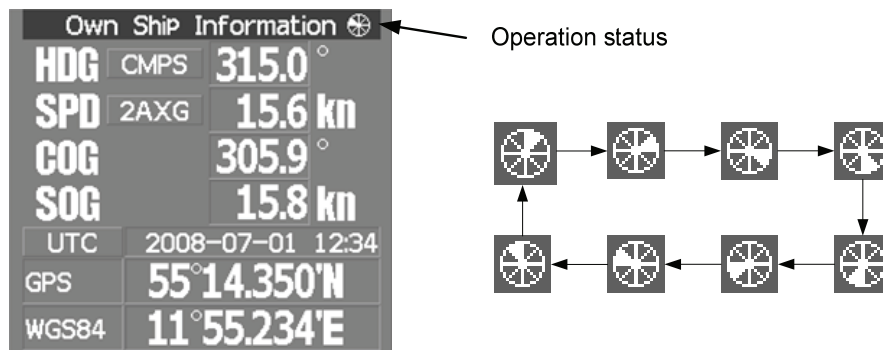

## 9.1.3 Fuse Checking

Melted fuses are caused by any clear cause. When a fuse is replaced, it is necessary to check the related circuits even if there is no trouble. In checking, note that there is some dispersion in the fusing characteristics. Table 9-8 shows a list of fuses used in the equipment.

**Table 9-9 Fuse List**

Location	Parts No.	Current Rating	Protection Circuit	Type
Radar process unit (JMA-5312-6/6HS)	F2	5A	I/F circuit PC410	ST4-5AN1
	F3	10A		ST6-10AN1
Radar process unit (JMA-5322-7/9/6HS, JMA-5332-12)	F2	10A	I/F circuit PC410	ST6-10AN1
	F3	10A		ST6-10AN1
GYRO I/F circuit	F1 to F4	0.5A	GYRO I/F circuit PC4201	MF51NR-0.5A



## 9.2 TROUBLE SHOOTING

As this radar equipment includes complicated circuits, it is necessary to request a specialist engineer for repair or instructions for remedy if any circuit is defective.

There are also troubles by the following causes, which should be referred to in checking or repair work.

### 1 Poor Contact in Terminal Board of Inter-Unit Cables

- Poor contact in terminal board
- The cable end is not fully connected, that it, contacted with earthed another terminal.
- Disconnected cable wire

### 2 Poor Contact of Connector within Unit

**Reference:** This radar equipment is provided with 9-9 standard spares.

**Table 9-10 Spares (7ZXRD0026, JMA-5312-6/6HS, 7ZXRD0015, JMA-5322-7/9/6HS, JMA-5332-12)**

#### 7ZXRD0026

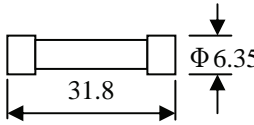
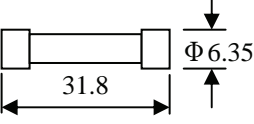
Name	Type/Code	Shape (mm)	In use	Spare	Parts No.	Location
Fuse	ST4-5AN1 (5ZFCA00050)		1	3	F2	Inside process unit
Fuse	ST6-10AN1 (5ZFCA00053)		1	3	F3	Inside process unit

#### 7ZXRD0015

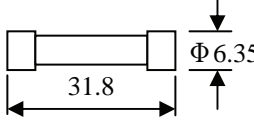
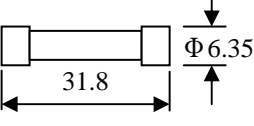
Name	Type/Code	Shape (mm)	In use	Spare	Parts No.	Location
Fuse	ST6-10AN1 (5ZFCA00053)		1	3	F2	Inside process unit
Fuse	ST6-10AN1 (5ZFCA00053)		1	3	F3	Inside process unit

**Table 9-11 Special Parts**

**[I] JMA-5312-6/6HS**

Parts No.	Name	Type	Manufacturer	Location	Code
V101	Magnetron	MAF1565N	NJRC	Scanner unit	5VHAA00102
A101/A102	Circulator	FCX68R	Toshiba	Scanner unit	5AJIX00027
A103	Dummy	NJC4002	NJRC	Scanner unit	5ANDF00001
A104	Filter	NJC9952	NJRC	Scanner unit	5AWAX00002
A301	Diode Limiter	NJS6930	NJRC	Scanner unit	5ATBT00006

**[II] JMA-5322-7/9/6HS**

Parts No.	Name	Type	Manufacturer	Location	Code
V101	Magnetron	M1568BS	NJRC	Scanner unit	5VMAA00106
A101/A102	Circulator	NJC3901M	NJRC	Scanner unit	5AJBV00007
A103	Dummy	NJC4002	NJRC	Scanner unit	5ANDF00001
A104	Filter	NJC9952	NJRC	Scanner unit	5AWAX00002
A301	Diode Limiter	NJS6930	NJRC	Scanner unit	5ATBT00006

**[III] JMA-5332-12**

Parts No.	Name	Type	Manufacturer	Location	Code
V101	Magnetron	M1555	NJRC	Scanner unit	5VMAA00104
A101	Circulator	NJC3316	NJRC	Scanner unit	5AJBV00008
A301	Diode Limiter	NJS6318	NJRC	Scanner unit	5ATBT00005



**Table 9-12 Circuit Block to be Repaired (JMA-5312-6/6HS)**

Location	Circuit Block	Type	Remarks
Scanner unit	Geared motor	7BDRD0048	DC brushless motor
Scanner unit	Motor control power circuit	CBD-1779	
Scanner unit	Encoder	CHT-71A	
Scanner unit	Fan	7BFRD0002	
Scanner unit	Performance Monitor	NJU-85	
Scanner unit	Modulator	CME-363	Excluding Magnetron
Scanner unit	Receiver	NRG-610	Including CAE-529-1
Scanner unit	Power supply circuit	CBD-1783	
Process unit	Radar processing circuit	CDC-1332	
Process unit	ARPA process circuit	NCA-877WA	
Process unit	ATA process circuit	NCA-877A	
Process unit	AIS process circuit	NQA-2103	
Process unit	GYRO/LOG I/F circuit	CMJ-304D	
Process unit	Terminal board circuit	CQD-1937A	
Process unit	I/F circuit	NQA-2123	
Process unit	Power circuit	NBD-818A	
Process unit	Fan	7BFRD0005	
Operation unit	Operation unit	CCK-979	
Operation unit	PS2 connector circuit	CQC-1204	
Operation unit	Trackball	CCK-1000	
LCD Monitor	Monitor fan	CBP-173A	
LCD Monitor	Interface circuit	CMH-2227	
LCD Monitor	Inverter circuit	CBF-38	
LCD Monitor	Brilliance circuit	CCK-989	
LCD Monitor	LCD Panel	CML-771	

**Table 9-13 Circuit Block to be Repaired (JMA-5322-7/9/6HS)**

Location	Circuit Block	Type	Remarks
Scanner unit	Geared motor	7BDRD0044A	DC brushless motor (normal speed)
Scanner unit	Geared motor	7BDRD0045A	DC brushless motor (high speed)
Scanner unit	Motor control power circuit	CBD-1779	
Scanner unit	Encoder	CHT-71A	
Scanner unit	Heater control circuit	CHG-216	Option (AC100V)
Scanner unit	Fan	7BFRD0002	
Scanner unit	Performance Monitor	NJU-85	
Scanner unit	Modulator unit	NMA-550	Including CPA-264 Including CMB-404 Including CFR-229 Excluding Magnetron
Scanner unit	Modulator circuit	CPA-264	
Scanner unit	Receiver unit	NRG-162A	Including CMA-866A
Scanner unit	T/R control circuit	CMC-1205R	
Scanner unit	Power supply circuit	CBD-1682A	
Process unit	Radar processing circuit	CDC-1332	
Process unit	ARPA process circuit	NCA-877WA	
Process unit	ATA process circuit	NCA-877A	
Process unit	AIS process circuit	NQA-2103	
Process unit	GYRO/LOG I/F circuit	CMJ-304D	
Process unit	Terminal board circuit	CQD-1937A	
Process unit	I/F circuit	NQA-2123	
Process unit	Power circuit	NBD-818A	
Process unit	Fan	7BFRD0005	
Operation unit	Operation unit	CCK-979	
Operation unit	PS2 connector circuit	CQC-1204	
Operation unit	Trackball	CCK-1000	
LCD Monitor	Monitor fan	CBP-173A	
LCD Monitor	Interface circuit	CMH-2227	
LCD Monitor	Inverter circuit	CBF-38	
LCD Monitor	Brilliance circuit	CCK-989	
LCD Monitor	LCD Panel	CML-771	



**Table 9-14 Circuit Block to be Repaired (JMA-5332-12)**

Location	Circuit Block	Type	Remarks
Scanner unit	Geared motor	MDBW10823	DC brushless motor
Scanner unit	Motor driver circuit	7EPRD0034	220VAC
Scanner unit	Motor driver circuit	7EPRD0035	110VAC
Scanner unit	Encoder	CHT-71A	
Scanner unit	Heater control circuit	CHG-215	Option (AC100V)
Scanner unit	Brake control circuit	CCB-655	
Scanner unit	Fan	7BFRD0002	
Scanner unit	Performance Monitor	NJU-84	
Scanner unit	Modulator unit	NMA-551	Including CPA-264 Including CMB-406 Including CFR-229 Excluding Magnetron
Scanner unit	Modulator circuit	CPA-264	
Scanner unit	Receiver unit	NRG-229	Including CAE-499 Including CAF-595
Scanner unit	T/R control circuit	CMC-1205R	
Scanner unit	Power supply circuit	CBD-1682A	
Scanner unit	Relay filter circuit	CSC-656	
Process unit	Radar processing circuit	CDC-1332	
Process unit	ARPA process circuit	NCA-877WA	
Process unit	ATA process circuit	NCA-877A	
Process unit	AIS process circuit	NQA-2103	
Process unit	GYRO/LOG I/F circuit	CMJ-304D	
Process unit	Terminal board circuit	CQD-1937A	
Process unit	I/F circuit	NQA-2123	
Process unit	Power circuit	NBD-818A	
Process unit	Fan	7BFRD0005	
Operation unit	Operation unit	CCK-979	
Operation unit	PS2 connector circuit	CQC-1204	
Operation unit	Trackball	CCK-1000	
LCD Monitor	Monitor fan	CBP-173A	
LCD Monitor	Interface circuit	CMH-2227	
LCD Monitor	Inverter circuit	CBF-38	
LCD Monitor	Brilliance circuit	CCK-989	
LCD Monitor	LCD Panel	CML-771	

---

## **9.3** AFTER-SALES SERVICE

### **9.3.1 Keeping period of maintenance parts**

Keeping period of maintenance parts is ten years from the production is discontinued.

### **9.3.2 When you Request for Repair**

If you suppose the product may be out of order, read the description in Section 9 carefully and check the suspected point again.

If it is still out of order, you are recommended to stop operation of the equipment and consult with the dealer from whom you purchased the product, or our branch office in your country or district, the sales department in our main office in Tokyo.

- **Repair within the Warranty Period**

If any failure occurs in the product during its normal operation in accordance with the instruction manual, the dealer or JRC will repair free of charge. In case that any failure is caused due to misuse, faulty operation, negligence or force major such as natural disaster and fire, the product will be repaired with charges.

- **Repair after the Warranty Period**

If any defective function of the product is recoverable by repair, the repair of it will be made at your own charge upon your request.

- **Necessary Information for Repair**

- ☆ Product name, model, manufacturing date and serial number
- ☆ Trouble conditions (as detailed as possible. Refer to “Radar Failure Check List” in page 9-10. )
- ☆ Name of company/organization, address and telephone number

### **9.3.3 Recommended Maintenance**

The performance of the product may deteriorate due to the secular change of the parts used in it, though such deterioration depends upon the conditions of operation.

So checkup and maintenance is recommendable for the product in addition to your daily care.

For maintenance, consult with the near-by dealer or our sales department.

Such maintenance will be made with charges.

For further details of after-sale service, contact the JRC Offices.



## Radar Failure Check List

When placing an order for repair of the product, it is requested that you could confirm the check items and fill the results and sent the sheet to our contact.

If there is any unclear items, contact the ship on which the product is installed, and give the correct information on the product.

Ship name: \_\_\_\_\_ Phone: \_\_\_\_\_ Fax: \_\_\_\_\_

Radar general model name: JMA- \_\_\_\_\_ Serial No. : \_\_\_\_\_

(Write the full model name correctly)

(1) Check the following items in the order of the number, and circle the applicable answer between YES or NO. If the item cannot be determined as YES or NO, explain in detail in the item (18), others.

(2) If any of the items (1) to (5) is marked as NO, check the fuse of the product (refer to Section 9.1.2 and 9.2).

(3) Check the items (4) to (17) while the transmission (TX) is ON.

\*Functions mentioned in the items (14), (15) and (17) may be optional, answer is not necessary.

No.	Check Item	Result	
		YES	NO
(1)	Power can be turned on. (The lamp on the Operation unit is lit)	YES	NO
(2)	A few minutes after powering-on, it will become standby status .	YES	NO
(3)	When powering-on (or TX ON), LCD monitor something is lit.	YES	NO
(4)	The antenna rotates at the transmission (TX) ON. (Check the following items while transmission is ON)	YES	NO
(5)	Current is supplied to the magnetron. (Refer to the instruction manual)	YES	NO
(6)	Turning is enabled. (Check with the range of 6 NM or more)	YES	NO
(7)	Fixed marker is displayed.	YES	NO
(8)	VRM is displayed.	YES	NO
(9)	While noise is displayed while set at SEA and RAIN minimum, GAIN maximum, IR-OFF and range 48 NM.	YES	NO
(10)	Target reflection echo is displayed.	YES	NO
(11)	Sensitivity of reflection echo is normal.	YES	NO
(12)	EBL is displayed.	YES	NO
(13)	Cursor mark moves.	YES	NO
*(14)	GYRO course can be set and normally displayed.	YES	NO
*(15)	LOG speed can be normally displayed.	YES	NO
(16)	Target tracking function works normally.	YES	NO
*(17)	If equipped with an interswitch, when switching from the straight mode (II) to (X), the failures (items marked NO) in the above (1) to (16), are switched over to the other unit.	YES	NO

(18) Others (Error message, etc.) \_\_\_\_\_

---



---



---



---



# SECTION 10 DISPOSAL

<b>10.1</b>	<b>DISPOSAL OF THE UNIT .....</b>	<b>10-1</b>
<b>10.2</b>	<b>DISPOSAL OF USED BATTERIES.....</b>	<b>10-1</b>
<b>10.3</b>	<b>DISPOSAL OF USED MAGNETRON .....</b>	<b>10-1</b>
<b>10.4</b>	<b>ABOUT THE CHINA ROHS.....</b>	<b>10-2</b>

---

## 10.1 DISPOSAL OF THE UNIT

When disposing of this unit, be sure to follow the local laws and regulations for the place of disposal.

## 10.2 DISPOSAL OF USED BATTERIES



### WARNING

**When disposing of used lithium batteries, be sure to insulate the batteries by taping the ⊕ and ⊖ terminals.**

**Otherwise, heat generation, explosion or a fire may occur.**

In this unit, Lithium batteries are used for the following parts:  
Radar Processing circuit (CDC-1332): BT1 (Maxell: CR2032)

- Do not store used lithium batteries. Dispose of them in accordance with regulations of local government.
- When disposing of used lithium batteries be sure to insulate the batteries by taping the ⊕ and ⊖ terminals. For disposal of batteries, be sure to follow the local laws and regulations. For detail, consult with the dealer you purchased the product our business office, or local government.

## 10.3 DISPOSAL OF USED MAGNETRON

Magnetron is used in the Scanner (NKE—1130/2103/2254)

- When the magnetron is replaced with a new one, return the used magnetron to our dealer or business office. For detail, consult with our dealer or business office.



# 10.4 ABOUT THE CHINA ROHS

## 有毒有害物质或元素的名称及含量

(Names & Content of toxic and hazardous substances or elements)

形式名(Type): JMA-5300MK2 Series

名称(Name): RADAR

部件名称 (Part name)	有毒有害物质或元素 (Toxic and Hazardous Substances and Elements)					
	铅 (Pb)	汞 (Hg)	镉 (Cd)	六价铬 (Cr6+)	多溴联苯 (PBB)	多溴二苯醚 (PBDE)
雷达天线单元 (Scanner Unit)	×	×	○	×	×	×
收发信单元 (Transmitter-receiver Unit)	×	×	×	×	×	×
主船内装置 (Inboard Unit) · 显示装置 (Display Unit) · 键盘装置 (OperationUnit) · 信号处理装置 (RADAR Process Unit)	×	×	×	×	×	×
外部设备 (Peripherals) · 选择 (Options) · 电线类 (Cables) · 手册 (Documentts)	×	×	×	×	×	×
<p>○: 表示该有毒有害物质在该部件所有均质材料中的含量均在SJ/T11306-2006 标准规定的限量要求以下。 (Indicates that this toxic, or hazardous substance contained in all of the homogeneous materials for this part is below the requirement in SJ/T11363-2006.)</p> <p>×: 表示该有毒有害物质至少在该部件的某一均质材料中的含量超出SJ/T11363-2006 标准规定的限量要求。 (Indicates that this toxic or hazardous substance contained in at least one of the homogeneous materials used for this part is above the limit requirement in SJ/T 11363-2006.)</p>						





# SECTION 11

## SPECIFICATIONS

11.1	JMA-5312-6/6HS TYPE RADAR .....	11-1
11.2	JMA-5322-7/9/6HS TYPE RADAR .....	11-2
11.3	JMA-5332-12 TYPE RADAR .....	11-3
11.4	SCANNER (NKE-2103-6) .....	11-4
11.5	SCANNER (NKE-2254-7/9) .....	11-5
11.6	SCANNER (NKE-1130).....	11-6
11.7	SCANNER (NKE-2103-6HS) .....	11-7
11.8	SCANNER (NKE-2254-6HS) .....	11-8
11.9	DISPLAY UNIT (NCD-4530).....	11-9
11.10	PROCESSOR UNIT (NDC-1417).....	11-10
11.11	TARGET TRACKING FUNCTION (OPTION) .....	11-12
11.12	AIS UNIT (NQA-2103) (OPTION) .....	11-13
11.13	PLOTTER.....	11-14
11.14	OPERATION UNIT (NCE-5171).....	11-15
11.15	PERFORMANCE MONITOR (NJU-84) (OPTION) .....	11-16
11.16	PERFORMANCE MONITOR (NJU-85) (OPTION) .....	11-16
11.17	AVAILABLE INPUT SIGNAL .....	11-17
11.18	AVAILABLE OUTPUT SIGNAL .....	11-18
11.19	STANDARD CONFIGURATION .....	11-18
11.20	EQUIPMENT DISTANCE BETWEEN OTHER INSTRUMENTS .....	11-19
11.21	OTHERS (OPTION) .....	11-19

# 11.1

## JMA-5312-6/6HS TYPE RADAR

(1) Class of emission	P0N
(2) Display	Color Raster Scan
(3) Screen	19-inch Color LCD Effective diameter of radar display, more than 250 mm
(4) Range Scale	0.125, 0.25, 0.5, 0.75, 1.5, 3, 6, 12, 24, 48, 96NM
(5) Range Resolution	Less than 30m
(6) Minimum Detectable Range	Less than 40m
(7) Range Accuracy	Less than 1% of the maximum distance of the range scale in use or less than 15m whichever is larger
(8) Bearing Accuracy	Less than 1°
(9) Bearing Indication	Relative Motion mode: Head-up/Course-up/North-up True Motion mode: Course-up/North-up
(10) Ambient Condition	According to IEC60945-4 Temperature Scanner: -25 to +55°C (Storage Temperature: -25 to +70°C) Other Unit except Scanner: -15 to +55°C Relative Humidity 93% at +40°C Vibration 2 to 13.2Hz, amplitude ±1mm ±10% 13.2 to 100Hz, Gravity acceleration 7m/s <sup>2</sup> Velocity of the wind 51.5m/s(100kt)
(11) Power Supply Input	+24VDC (Display Unit) +24VDC (Scanner) * Display Unit correspond to 100/110/115/220/230/240VAC when use NBA-5111.
(12) Power Consumption	Approx. 620W (In maximum wind resistant velocity)
(13) Power Supply Voltage Fluctuation	+24VDC -10/+50% (Display Unit) +24VDC -10/+50% (Scanner Unit)
(14) Pre-heating Time	Approx. Within 1min30sec



# 11.2 JMA-5322-7/9/6HS TYPE RADAR

(1) Class of emission	P0N
(2) Display	Color Raster Scan
(3) Screen	19-inch Color LCD Effective diameter of radar display, more than 250 mm
(4) Range Scale	0.125, 0.25, 0.5, 0.75, 1.5, 3, 6, 12, 24, 48, 96NM
(5) Range Resolution	Less than 30m
(6) Minimum Detectable Range	Less than 40m
(7) Range Accuracy	Less than 1% of the maximum distance of the range scale in use or less than 15m whichever is larger
(8) Bearing Accuracy	Less than 1°
(9) Bearing Indication	Relative Motion mode: Head-up/Course-up/North-up True Motion mode: Course-up/North-up
(10) Ambient Condition	According to IEC60945-4 Temperature Scanner: -25 to +55°C (Storage Temperature: -25 to +70°C) Other Unit except Scanner: -15 to +55°C Relative Humidity 93% at +40°C Vibration 2 to 13.2Hz, amplitude $\pm 1\text{mm} \pm 10\%$ 13.2 to 100Hz, Gravity acceleration $7\text{m/s}^2$ Velocity of the wind 51.5m/s (100kt)
(11) Power Supply Input	+24VDC (Display Unit) +24VDC (Scanner) * Display Unit correspond to 100/110/115/220/230/240VAC when use NBA-5111.
(12) Power Consumption	Approx. 700W (In maximum wind resistant velocity)
(13) Power Supply Voltage Fluctuation	+24VDC $-10/+50\%$ (Display Unit) +24VDC $-10/+50\%$ (Scanner Unit)
(14) Pre-heating Time	Approx. Within 3min

# 11.3 JMA-5332-12 TYPE RADAR

(1) Class of emission	P0N
(2) Display	Color Raster Scan
(3) Screen	19-inch Color LCD Effective diameter of radar display, more than 250 mm
(4) Range Scale	0.125, 0.25, 0.5, 0.75, 1.5, 3, 6, 12, 24, 48, 96NM
(5) Range Resolution	Less than 30m
(6) Minimum Detectable Range	Less than 40m
(7) Range Accuracy	Less than 1% of the maximum distance of the range scale in use or less than 15m whichever is larger
(8) Bearing Accuracy	Less than 1°
(9) Bearing Indication	Relative Motion mode: Head-up/Course-up/North-up True Motion mode: Course-up/North-up
(10) Ambient Condition	According to IEC60945-4 Temperature Scanner: -25 to +55°C (Storage Temperature: -25 to +70°C) Other Unit except Scanner: -15 to +55°C Relative Humidity 93% at +40°C Vibration 2 to 13.2Hz, amplitude ±1mm ±10% 13.2 to 100Hz, Gravity acceleration 7m/s <sup>2</sup> Velocity of the wind 51.5m/s(100kt)
(11) Power Supply Input	+24VDC (Display Unit) 100/110/120/220/230/240VAC, 1 Φ, 50/60Hz (Scanner) * Display Unit correspond to 100/110/115/220/230/240VAC when use NBA-5111.
(12) Power Consumption	Approx. 240W +1600VA (In maximum wind resistant velocity)
(13) Power Supply Voltage Fluctuation	+24VDC -10/+50% (Display Unit) 100/110/115/220/230/240VAC ±10% (Scanner Unit)
(14) Pre-heating Time	Approx. Within 3min



# 11.4 SCANNER (NKE-2103-6)

(1) Dimensions	Height 457mm×Swing Circle 1910mm
(2) Mass	Approx. 40kg
(3) Polarization	Horizontal Polarization
(4) Directional Characteristic	Horizontal Beam Width: 1.2° (-3dB width) Vertical Beam Width: 20° (-3dB width) Sidelobe Level: Below -26dB (within ±10°) Below -30dB (outside ±10°)
(5) Revolution	Approx. 27rpm (Normal)
(6) Peak Power	10kW±50%
(7) Transmitting Frequency	9410 ±30MHz
(8) Transmitting Tube	Magnetron [MAF1565N]
(9) Pulse width/Repetition Frequency	SP1:0.08uS/2250Hz MP1:0.25uS/1700Hz,MP2:0.5uS/1200Hz LP1:0.8uS/750Hz,LP2:1.0uS/650Hz 0.125NM SP1 0.25NM SP1 0.5NM SP1 0.75NM SP1 / MP1 1.5NM SP1 / MP1 / MP2 3NM MP1 / MP2 / LP1 6NM MP1 / MP2 / LP1 / LP2 12NM MP1 / MP2 / LP1 / LP2 24NM MP2 / LP1 / LP2 48NM LP2 96NM LP2
(10) Duplexer	Circulator + Diode Limiter
(11) Mixer	MIC Front End
(12) Intermediate Frequency Amplifier	Intermediate Frequency: 60MHz Band Width: 20MHz(0.08μS) 6MHz(0.25μS,0.5μS) 3MHz(0.8μS, 1μS) Gain: More than 90dB Amplifying Characteristics: Logarithmic Amplifier
(13) Overall Noise Figure	7.5dB(Average)

# 11.5 SCANNER (NKE-2254-7/9)

- |      |                                  |   |
|------|----------------------------------|---|
| (1)  | Dimensions                       | 25kW-7ft: Height 536mm×Swing Circle 2270mm<br>25kW-9ft: Height 536mm×Swing Circle 2825mm  |
| (2)  | Mass                             | 25kW-7ft: Approx. 58 kg<br>25kW-9ft: Approx. 60 kg  |
| (3)  | Polarization                     | Horizontal Polarization   |
| (4)  | Directional Characteristics      | Horizontal Beam Width: 1.0° (7ft, -3dB width)<br>0.8° (9ft, -3dB width)<br>Vertical Beam Width 20° (7/9ft, -3dB width)<br>Sidelobe Level: Below -26dB<br>(7/9ft, within ±10°)<br>Below -30dB<br>(7/9ft, outside ±10°)   |
| (5)  | Revolution                       | 24rpm (7/9ft, Normal)   |
| (6)  | Peak Power                       | 25kW ±50%   |
| (7)  | Transmitting Frequency           | 9410 ±30MHz   |
| (8)  | Transmitting Tube                | Magnetron [M1568BS]   |
| (9)  | Pulse Width/Repetition Frequency | SP1:0.07uS/2250Hz<br>MP1:0.2uS/2250Hz,MP2:0.3uS/1900Hz,MP3:0.4uS/1400Hz<br>LP1:0.8uS/750Hz,LP2:1.0uS/650Hz,LP3:1.2uS/510Hz<br>0.125NM SP1<br>0.25NM SP1<br>0.5NM SP1<br>0.75NM SP1 / MP1<br>1.5NM SP1 / MP1 / MP2 / MP3<br>3NM MP1 / MP2 / MP3 / LP1<br>6NM MP1 / MP2 / MP3 / LP1 / LP2<br>12NM MP1 / MP2 / MP3 / LP1 / LP2<br>24NM MP3 / LP1 / LP2<br>48NM LP2<br>96NM LP3 |
| (10) | Duplexer                         | Circulator + Diode Limiter  |
| (11) | Mixer                            | MIC Front End   |
| (12) | Intermediate Frequency Amplifier | Intermediate Frequency: 60MHz<br>Band Width: 25MHz(0.07μS)<br>8MHz(0.2μS, 0.3μs, 0.4μS)<br>3MHz(0.8μS, 1μS, 1.2μS)<br>Gain: More than 90dB<br>Amplifying Characteristics: Logarithmic Amplifier   |
| (13) | Overall Noise Figure             | 7.5dB(Average)  |



# 11.6 SCANNER (NKE-1130)

(1) Dimensions	Height 791mm×Swing Circle 4000mm
(2) Mass	Approx. 180kg
(3) Polarization	Horizontal Polarization
(4) Directional Characteristics	Horizontal Beam Width 12ft: 1.9° Vertical Beam Width 12ft: 25° Sidelobe Level: Below -26dB (within ±10°) Below -30dB (outside ±10°)
(5) Revolution	24rpm (60/50Hz)
(6) Peak Power	30kW ±50%
(7) Transmitting Frequency	3050 ±20MHz
(8) Transmitting Tube	Magnetron M1555
(9) Pulse Width/Repetition Frequency	SP1:0.07uS/2250Hz MP1:0.2uS/2250Hz,MP2:0.3uS/1900Hz,MP3:0.4uS/1400Hz LP1:0.8uS/750Hz,LP2:1.0uS/650Hz,LP3:1.2uS/510Hz 0.125NM SP1 0.25NM SP1 0.5NM SP1 0.75NM SP1 / MP1 1.5NM SP1 / MP1 / MP2 / MP3 3NM MP1 / MP2 / MP3 / LP1 6NM MP1 / MP2 / MP3 / LP1 / LP2 12NM MP1 / MP2 / MP3 / LP1 / LP2 24NM MP3 / LP1 / LP2 48NM LP2 96NM LP3
(10) Duplexer	Circulator + Diode Limiter
(11) Mixer	MIC Front End
(12) Intermediate Frequency Amplifier	Intermediate Frequency: 60MHz Band Width: 25MHz(0.07uS) 8MHz(0.2μS, 0.3μS, 0.4μS) 3MHz(0.8μS, 1.0μS, 1.2μS) Gain: More than 90dB Amplifying Characteristics: Logarithmic Amplifier
(13) Overall Noise Figure	7.5dB(Average)

# 11.7 SCANNER (NKE-2103-6HS)

(1) Dimensions	Height 457mm×Swing Circle 1910mm
(2) Mass	Approx. 40kg
(3) Polarization	Horizontal Polarization
(4) Directional Characteristic	Horizontal Beam Width: 1.2° (-3dB width) Vertical Beam Width: 20° (-3dB width) Sidelobe Level: Below -26dB (within ±10°) Below -30dB (outside ±10°)
(5) Revolution	Approx. 48rpm
(6) Peak Power	10kW±50%
(7) Transmitting Frequency	9410 ±30MHz
(8) Transmitting Tube	Magnetron [MAF1565N]
(9) Pulse width/Repetition Frequency	SP1:0.08uS/2250Hz MP1:0.25uS/1700Hz,MP2:0.5uS/1200Hz LP1:0.8uS/750Hz,LP2:1.0uS/650Hz 0.125NM SP1 0.25NM SP1 0.5NM SP1 0.75NM SP1 / MP1 1.5NM SP1 / MP1 / MP2 3NM MP1 / MP2 / LP1 6NM MP1 / MP2 / LP1 / LP2 12NM MP1 / MP2 / LP1 / LP2 24NM MP3 / LP1 / LP2 48NM LP2 96NM LP2
(10) Duplexer	Circulator + Diode Limiter
(11) Mixer	MIC Front End
(12) Intermediate Frequency Amplifier	Intermediate Frequency: 60MHz Band Width: 20MHz(0.08μS) 6MHz(0.25μS,0.5μS) 3MHz(0.8μS, 1μS) Gain: More than 90dB Amplifying Characteristics: Logarithmic Amplifier
(13) Overall Noise Figure	7.5dB(Average)





# 11.8 SCANNER (NKE-2254-6HS)

(1) Dimensions	25kW-6ft: Height 536mm×Swing Circle 1910mm																						
(2) Mass	Approx. 55 kg																						
(3) Polarization	Horizontal Polarization																						
(4) Directional Characteristics	<table border="0"> <tr> <td>Horizontal Beam Width:</td> <td>1.2°</td> </tr> <tr> <td>Vertical Beam Width</td> <td>20° (-3dB width)</td> </tr> <tr> <td>Sidelobe Level:</td> <td>Below -26dB (within ±10°) Below -30dB (outside ±10°)</td> </tr> </table>	Horizontal Beam Width:	1.2°	Vertical Beam Width	20° (-3dB width)	Sidelobe Level:	Below -26dB (within ±10°) Below -30dB (outside ±10°)																
Horizontal Beam Width:	1.2°																						
Vertical Beam Width	20° (-3dB width)																						
Sidelobe Level:	Below -26dB (within ±10°) Below -30dB (outside ±10°)																						
(5) Revolution	48rpm (Normal)																						
(6) Peak Power	25kW ±50%																						
(7) Transmitting Frequency	9410 ±30MHz																						
(8) Transmitting Tube	Magnetron [M1568BS]																						
(9) Pulse Width/Repetition Frequency	<p>SP1:0.07uS/2250Hz  MP1:0.2uS/2250Hz,MP2:0.3uS/1900Hz,MP3:0.4uS/1400Hz  LP1:0.8uS/750Hz,LP2:1.0uS/650Hz,LP3:1.2uS/510Hz</p> <table border="0"> <tr><td>0.125NM</td><td>SP1</td></tr> <tr><td>0.25NM</td><td>SP1</td></tr> <tr><td>0.5NM</td><td>SP1</td></tr> <tr><td>0.75NM</td><td>SP1 / MP1</td></tr> <tr><td>1.5NM</td><td>SP1 / MP1 / MP2 / MP3</td></tr> <tr><td>3NM</td><td>MP1 / MP2 / MP3 / LP1</td></tr> <tr><td>6NM</td><td>MP1 / MP2 / MP3 / LP1 / LP2</td></tr> <tr><td>12NM</td><td>MP1 / MP2 / MP3 / LP1 / LP2</td></tr> <tr><td>24NM</td><td>MP3 / LP1 / LP2</td></tr> <tr><td>48NM</td><td>LP2</td></tr> <tr><td>96NM</td><td>LP3</td></tr> </table>	0.125NM	SP1	0.25NM	SP1	0.5NM	SP1	0.75NM	SP1 / MP1	1.5NM	SP1 / MP1 / MP2 / MP3	3NM	MP1 / MP2 / MP3 / LP1	6NM	MP1 / MP2 / MP3 / LP1 / LP2	12NM	MP1 / MP2 / MP3 / LP1 / LP2	24NM	MP3 / LP1 / LP2	48NM	LP2	96NM	LP3
0.125NM	SP1																						
0.25NM	SP1																						
0.5NM	SP1																						
0.75NM	SP1 / MP1																						
1.5NM	SP1 / MP1 / MP2 / MP3																						
3NM	MP1 / MP2 / MP3 / LP1																						
6NM	MP1 / MP2 / MP3 / LP1 / LP2																						
12NM	MP1 / MP2 / MP3 / LP1 / LP2																						
24NM	MP3 / LP1 / LP2																						
48NM	LP2																						
96NM	LP3																						
(10) Duplexer	Circulator + Diode Limiter																						
(11) Mixer	MIC Front End																						
(12) Intermediate Frequency Amplifier	<p>Intermediate Frequency: 60MHz  Band Width: 25MHz(0.07μS)  8MHz(0.2μS, 0.3μS, 0.4μS)  3MHz(0.8μS, 1μS, 1.2μS)</p> <p>Gain: More than 90dB  Amplifying Characteristics: Logarithmic Amplifier</p>																						
(13) Overall Noise Figure	7.5dB(Average)																						

---

# 11.9 DISPLAY UNIT (NCD-4530)

- |                            |  |
|----------------------------|--|
| (1) Structure              | Desk Top Type<br>(LCD Monitor/Operation Unit/Processor Unit Separation Structure)  |
| (2) Screen                 | 19-inch Color LCD 1280x1024 dot (SXGA)<br>Viewing Distance: 1m from the center of Display  |
| (3) Display mode           | Radar mode<br>Synthesis mode (Synthesis Radar echo and Coastline)<br>Plotter mode (Require Plotter Unit (option))  |
| (4) Range Scale            | 0.125, 0.25, 0.5, 0.75, 1.5, 3, 6, 12, 24, 48, 96NM  |
| (5) Range Marker           | 0.025, 0.05, 0.1, 0.25, 0.25, 0.5, 1, 2, 4, 8, 16NM  |
| (6) Bearing Indication     | Rader mode/Synthesis mode<br>Relative motion: North-up, Course-up, Head-up<br>True motion: North-up, Course-up<br>True motion (Plotter mode (Option)): N-up, C-up                                  |
| (7) Variable Range Maker   | 2VRM (Digital Display)<br>VRM unit of Display: NM<br>VRM Range:0.000 to 100.2NM  |
| (8) Electric Bearing lines | 2EBL(Digital Display)<br>Each EBL can be floating displayed.<br>EBL unit of Display: 0.1°<br>EBL Range: 0.000° to 359.9°<br>Bearing Indication: Relative bearing and True bearing can be switched. |
| (9) Cursor                 | Target Range, Bearing and Latitude presentation can be possible to move with trackball.  |



# 11.10 PROCESSOR UNIT (NDC-1417)

- |                                  |  |
|----------------------------------|--|
| (1) Structure                    | Desk Top Type (Horizontal putting and length putting using combined)   |
| (2) Dimensions                   | Height 170mm×Width 300mm×Depth 320mm   |
| (3) Mass                         | Approx. Below 10kg   |
| (4) Tune Method                  | AUTO/MANUAL(Bar-graph indicate)  |
| (5) STC (SEA)                    | AUTO/MANUAL  |
| (6) FTC (RAIN)                   | AUTO/MANUAL  |
| (7) Radar Interference Rejection | Built-in (The effect can be adjusted by three stages.)   |
| (8) Scan Correlation             | Function1/2/3, 2 Peak Hold Processing1/2<br>Automatic change of processing method.<br>(Target range synchronize/Clutter synchronize)   |
| (9) Bearing Marker               | 360° in 1° digit.<br>Relative motion: Fixation<br>True motion: Rewrite at a position correct in every scan.  |
| (10) Heading Line                | Electronic (Stern Line can be displayed.)  |
| (11) Radar Alarm                 | Invasion, Seccession, OFF can be selected.<br>With buzzer sound.(Possible to output to external buzzer. )<br>Ring.<br>Automatically acquisition by target tracking described in Section "TARGET TRACKING". |
| (12) Off Center                  | Within 66% of the radius of any range. (Except 96NM)<br>Can be operated in all mode in relative motion.<br>Trail is succeed at Off Center mode.  |
| (13) True motion Unit            | Built-in (Except 96NM)   |
| (14) True motion reset position  | 66% of radius of any range.<br>Possible to manual reset.   |
| (15) Twice zoom                  | The zoom center is 66% radius of any range. (Except 0.125NM)   |

- 
- (16) Radar trails indication
- True motion mode:(Only true motion trails  
Relative motion mode:  
True motion trails and relative motion trails can be selected.  
Trail time length:  
15 sec/30 sec/1 min/3 min/6 min/10 min/15 min/30 min/60  
min/Continuous/OFF  
Arbitrary trail time length can be displayed at any time.  
Possible to display time series trail and continuous trail by color  
classification.  
Built-in Trail thinning process.  
Trail function can be use at true motion reset.  
When range is changed, Trail function can be use.  
Trail function can be use at Off Center. (Relative motion)  
When motion indication and bearing indication changed, Trail  
function can be use.(Only true motion trails indication.)
- (17) Variety of Pulse width
- SP1/MP1/MP2/LP1/LP2(NKE-2103)  
SP1/SP2/MP1/MP2/MP3/LP1/LP2/LP3(NKE-2254/NKE-1130)
- (18) Target enhance
- 3 stages can be changed.
- (19) Correct position
- When synthesis Radar and Coastline is displayed, position can be  
corrected by manually.
- (20) Display color
- Radar echo: 16 stages (Yellow, Green, Amber, Purple, Red)  
Radar trails: 16 stages (White, Cyan, Green)  
Fixed Maker: 4 colors (White, Cyan, Green, Amber)  
VRM1/2,EBL1/2,PI: 4 colors (White, Cyan, Green, Amber)  
Character/Bearing Marker: 5 colors (White, Green, Amber, Black,  
Red)  
Cursor: 4 colors (White, Cyan, Green, Amber)  
Heading Line/Vector: 4 colors (Cyan, Green, Amber, Black)  
Own Ship's track/Another Ship's track: 7 colors  
Coastline/Isobaths: 16 colors  
Mark/Line: 7 colors



# 11.11

## TARGET TRACKING FUNCTION (OPTION)

### Radar mode, synthesis mode

- |                                |  |
|--------------------------------|--|
| (1) Available range scale      | All range  |
| (2) Acquisition                | MANUAL/AUTO (by two automatic acquisition/activation zone)   |
| (3) Tracking                   | Normal edition type NCA-877A: 30 target<br>High performance type NCA-877WA: 100 target<br>Maximum tracking range: 32NM (Available all range scale)   |
| (4) Display                    | Tracking data: 4 at the same time. (Can be scroll.)<br>Naming function: Possible to name by the alphabet up to 8 characters to each target.<br>The range, bearing, CPA, TCPA, true course, true speed, BCR, BCT of target can be displayed. (When naming is displayed, BCR/BCT can't be displayed.)<br>Vector display: True/Relative Past position |
| (5) Alarm                      | Automatic acquisition/activation zone<br>Danger ship: Depends on CPA/TCPA setting.   |
| (6) Trial Maneuver (NCA-877WA) | Input parameter: Course, Speed, Vector time, Time to Maneuver, Reach, Turn Radius, Acceleration, Deceleration  |

### Synthesis mode

- |                        |  |
|------------------------|--|
| (7) Another ship track | 20 targets. 1500 point per one target can be displayed. (Own ship track and marks are another.)<br>Display color: 7 colors (The display color of each target can be set.)<br>(The display color of all targets can be set by the batch. In this case, the display color is one color.)<br>Interval of save: 3/5/10/30 sec, 1/3/5/10/130/160 min, 1/3/5/10 NM<br>Possible to storage in memory card (Option). |
|------------------------|--|

**Note:** ARPA Process Unit (NCA-877WA) or ATA Process Unit (NCA-877A) must be fitted on ships compliant to IMO.

---

# 11.12 AIS UNIT (NQA-2103) (OPTION)

## Radar mode, synthesis mode

- (1) Activation 100 target  
MANUAL/AUTO(by two automatic activation/activation zone)
- (2) Display 300 target (sleeping target and activated target)  
AIS data: 2 at the same time. (simple display)  
The ship's name, call sign, MMSI, course, speed, CPA, TCPA of target can be displayed. (simple display item)  
The ship's name, call sign, MMSI, course, speed, CPA, TCPA, bearing, range, ship's heading bearing, rate of turn, latitude, longitude, destination, navigation status of target can be displayed. (detail display item)  
Vector display: True/Relative  
Past position  
The message can be displayed. (broadcast message, addressed message)
- (3) Alarm Automatic activation/activation zone  
Danger ship: Depends on CPA/TCPA setting.

## Synthesis mode

- (4) Another ship track 20 targets. 1500 point per one target can be displayed.  
(Own ship track and marks are another.)  
Display color: 7 colors  
(The display color of each target can be set.)  
(The display color of all targets can be set by the batch. In this case, the display color is one color.)  
Interval of save: 3/5/10/30 sec, 1/3/5/10/130/160 min, 1/3/5/10 NM  
Possible to storage in memory card (Option).

**Note:** AIS Process Unit must be fitted on ships compliant to IMO.



# 11.13 PLOTTER

## (1) Plotter (Normal) (Synthesis mode)

Projection:	Mercator projection (Latitude 85 degree or less.)
Scale:	Radar synchronize range scale
Own ship track:	1 color(Cyan) Interval of save 3/5/10/30 sec, 1/3/5/10/30/60 min or every 0.1/0.2/0.3/0.5/1/3/5/10 NM and Off Capacity 7,000 point
Cursor mark:	7 colors Capacity of cursor mark: 2,000 point Variety of cursor Mark: 29
Line:	7 colors Capacity of line: Include in cursor mark Variety of line: Solid line, broken line, alternate long and short dash line
Coastline data:	Coastline ROM Card (Option) (ERC, JRC, C-Map NT+) One selected depth contour can be displayed.
External memory:	Memory card (Option)
Position correction:	Latitude / Longitude correction Radar video synchronize range scale coast line by manual. (Synthesis mode)

## (2) Plotter (Option NDB-34A) (Synthesis mode, Plotter mode)

Projection:	Mercator projection (Latitude 70 degree or less.)
Scale:	Synchronize range scale
Own ship track:	7 colors. Interval of save: 3/5/10/30 sec, 1/3/5/10/30/60 min or every 0.1/0.2/0.3/0.5/1/3/5/10 NM and Off Capacity of own ship track: 7,000 point
Cursor mark:	7 colors Capacity of cursor mark: 20,000 point Variety of cursor Mark: 29
Line:	7 colors Capacity of line: Include in cursor mark Variety of line: Solid line, broken line, alternate long and short dash line
Coast line data:	Coast line ROM card (Option)(ERC, JRC, C-Map NT+) Selected one depth contour can be displayed.
External memory:	Memory card (Option)
Waypoint and route:	Waypoint can be set up to 999 point. Information of waypoint: Azimuth, distance and the time to required destination. Setting of sea route: 10 sea routes. (20 destination for one route can be set.) Alarm of route: Waypoint arrival / break off, Route arrival / break off
Position correction:	Latitude / Longitude correction Radar video synchronize range scale coast line by manual. (Synthesis mode)

# 11.14

## OPERATION UNIT (NCE-5171)

- (1) Structure                      Structure of operation unit is separate from processor unit.  
Desk-Top type  
Correspond Flush mount
- (2) Switch                         Gain (Transmit pulse width can be changed by PUSH-SW.)  
SEA (AUTO/MANU can be changed by PUSH-SW.)  
RAIN (AUTO/MANU can be changed by PUSH-SW.)  
MULTI (Adjustment item can be changed by PUSH-SW.)  
EBL (Floating EBL ON/OFF can be changed by PUSH-SW.)  
VRM  
Trackball
- (3) Operation switch
- |   |   |
|---|---|
| STBY/OFF (Standby/Power off):             | Stop transmit, Power off.   |
| TX/OFF (Transmit start/Power off):        | Start transmit, Power off   |
| PANEL(Brightness of keyboard adjustment): | Brightness of keyboard switch adjust.                             |
| ALARM ACK(Stop Alarm):                    | Acknowledge and stop alarm.                                       |
| EBL1(EBL1):                               | Selection display and non-display of EBL1.                        |
| EBL2(EBL2):                               | Selection display and non-display of EBL2.                        |
| VRM1(VRM1):                               | Selection display and non-display of VRM1.                        |
| VRM2(VRM2):                               | Selection display and non-display of VRM2.                        |
| RANGE+(Increase display range):           | Increase display range.   |
| RANGE-(decrease display range):           | Decrease display range.   |
| ACQ(acquisition):                         | Target acquisition  |
| TGT DATA(Numeric display):                | Numeric display of tracking target.                               |
| TGT CNCL(Release of selection):           | Release of selection of tracking target.                          |
| MOB(Marker):                              | Turning on and release marker.                                    |
| ENT(Enter):                               | Left side button of trackball.                                    |
| CLR/INFO(Release/Information):            | Right side of trackball.  |
| MAP(Display mode):                        | Selection display and non-display of MAP(NAV LINE, etc...).       |
|   | Selection of Rader, Synthesis and Plotter mode.                   |
| AZI MODE(Display azimuth):                | Selection of North-up, Course-Up, Head-Up.                        |
| TM/RM(True/Relative Motion):              | Selection true motion, relative motion.                           |
| RR/HL(Fixed ring/Heading Line):           | Selection display and non-display of fixed ring and heading line. |
| OFF CENT(Off Center):                     | Off center operation  |
| AZ (Acquisition/Activate zone):           | Setting and release of acquisition/activation zone.               |
| VECT T/R (True/Relative motion vector):   | Selection of true motion and relative motion of vector.           |
| TRAILS (Trails):                          | Selection display and non-display of trails.                      |
| DAY/NIGHT:                                | Selection of screen arrangement of color.                         |
| FUNC(Function):                           | Selection of signal processing.                                   |
| USER KEY1(User key1):                     | User assignment key1.   |
| USER KEY2(User key2):                     | User assignment key2.   |
| RADAR MENU(Radar menu):                   | Rader menu.   |
| MARK(MARK):                               | Selection display and non-display of mark.                        |
| TT MENU(TT menu):                         | Target tracking menu.   |





## **11.15** PERFORMANCE MONITOR (NJU-84) (OPTION)

- |                         |                                     |
|-------------------------|-------------------------------------|
| (1) Dimensions          | Height 130mm×Width 180mm×Depth 70mm |
| (2) Mass                | Approx. 1.2kg                       |
| (3) Operating Frequency | 3050±30MHz                          |

**Note:** Performance monitor must be fitted on ships compliant to IMO.

## **11.16** PERFORMANCE MONITOR (NJU-85) (OPTION)

- |                         |                                     |
|-------------------------|-------------------------------------|
| (1) Dimensions          | Height 130mm×Width 149mm×Depth 70mm |
| (2) Mass                | Approx. 1.2kg                       |
| (3) Operating Frequency | 9410±30MHz                          |

**Note:** Performance monitor must be fitted on ships compliant to IMO.

# 11.17

## AVAILABLE INPUT SIGNAL

Receive capability Port: .NAV1, NAV2, GPS port at terminal board TB4303. NMEA Connector at rear of the process unit (D-Sub 9 PIN)

- (1) Navigation equipment: IEC61162-1/2  
Longitude/Latitude: GGA>RMC>RMA>GNS/GLL  
Waypoint: RMB>BWC>BWR  
COG/SOG: RMC>RMA>VTG  
SPEED: VBW  
Day/Time information: ZDA  
Alarm acknowledge: ACK  
  
Rate of Turn : ROT  
  
Rudder : RSA
- (2) Bearing signal: GYRO-SYNC: 360X, 180X, 90X, 30X. (GYRO I/F Unit)  
GYRO-STEP: 360X, 180X, 90X, 30X. (GYRO I/F Unit)  
JRC-NSK format (JLR-10,20,30) (COMPASS Connector at rear of the process unit)  
IEC61162-2 38400bps: THS>HDT (over 40Hz) (COMPAS port at terminal board TB4303).  
IEC61162-1 4800bps: HDT>HDG>HDM>VHW (COMPAS port at terminal board TB4303). ※Can't be use for target tracking.
- (3) Speed signal: LOG-SYNC: 360X, 180X,90X, 30X. (GYRO I/F Unit)  
LOG-PULSE: 800, 400, 200, 100. (GYRO I/F Unit)
- (4) External event mark: Contact input (EVENT port at terminal board TB4303).
- (5) Radar buoy: Negative input (RBVD port at terminal board TB4302).
- (6) Depth: DPT>DBS>DBT>DBK, JRC format
- (7) Water temperature: MTW, JRC format
- (8) Tendency: CUR, JRC format
- (9) Direction of wind, velocity of wind: MWV, MWD
- (10) AIS: VDM, VDO

Note: The Speed measuring accuracy of speed sensor shall confirm to IMO Resolution MSC.96(72).  
The measuring accuracy of GPS shall confirm to IMO Resolution MSC.112(73).



# 11.18

## AVAILABLE OUTPUT SIGNAL

- |     |                        |  |
|-----|------------------------|--|
| (1) | Slave video            | Radar video: TIY, VD, BP(2048p), BZ (Terminal board TB4302)  |
| (2) | Navigation information | Send capability Port: .NAV1, NAV2, GPS port at terminal board TB4303.<br>NMEA Connector at rear of the process unit (D-Sub 9 PIN). IEC61162-1/2<br>Radar system data: RSD<br>Own ship data: OSD<br>Tracking target data: TTM, TLL, TTD, TLB, JRC-ARPA<br>AIS target data: TTM, TLL, TTD, TLB<br>Alarm: ALR<br>Auto pilot: APB<br>Bearing of destination: BOD<br>Latitude/Longitude data: GGA, GLL, RMC<br>Waypoint data: RMB, BWC<br>COG/SOG data: VTG<br>Cross track error: XTE<br>Heading data: HDT, THS |
| (3) | External alarm         | Default setting: normally closed contact<br>Maximum current: 200mA<br>(SYSALM, ARPAALM port at terminal board TB4303).   |
| (4) | External monitor       | Multi scan monitor, Analog RGB, HD15pin Connector  |

# 11.19

## STANDARD CONFIGURATION

- |     |                         |  |
|-----|-------------------------|--|
| (1) | Scanner                 | 1  |
| (2) | Display unit            | 1 (Process unit, LCD unit, Operation unit)   |
| (3) | Equipment cable         | 10/25kW<br>Standard:20m<br>30kW<br>Display unit to junction box      Standard:10m<br>Junction box to scanner              Standard:20m |
| (4) | Equipment reserve parts | 1  |
| (5) | Instruction manual      | 1 (Japanese or English)  |

---

# 11.20

## EQUIPMENT DISTANCE BETWEEN OTHER INSTRUMENTS

	Maximum	Standard
(1) LCD monitor to processor unit	5m	5m
(2) Keyboard unit to processor unit	5m	5m
(3) Scanner to display unit (10/25kw)	65m	20m
(4) Scanner to junction box (30kW)	50m <sup>*1</sup>	20m
(5) Junction box to display unit(30kW)	30m <sup>*1</sup>	10m

\*1 Total distance between scanner and display unit must be 65m or less.

# 11.21

## OTHERS (OPTION)

- Coast line ROM card
- Memory card
- Interswitch unit (NQE-3141)
- Rectifier unit (NBA-5111)

# APPENDIX

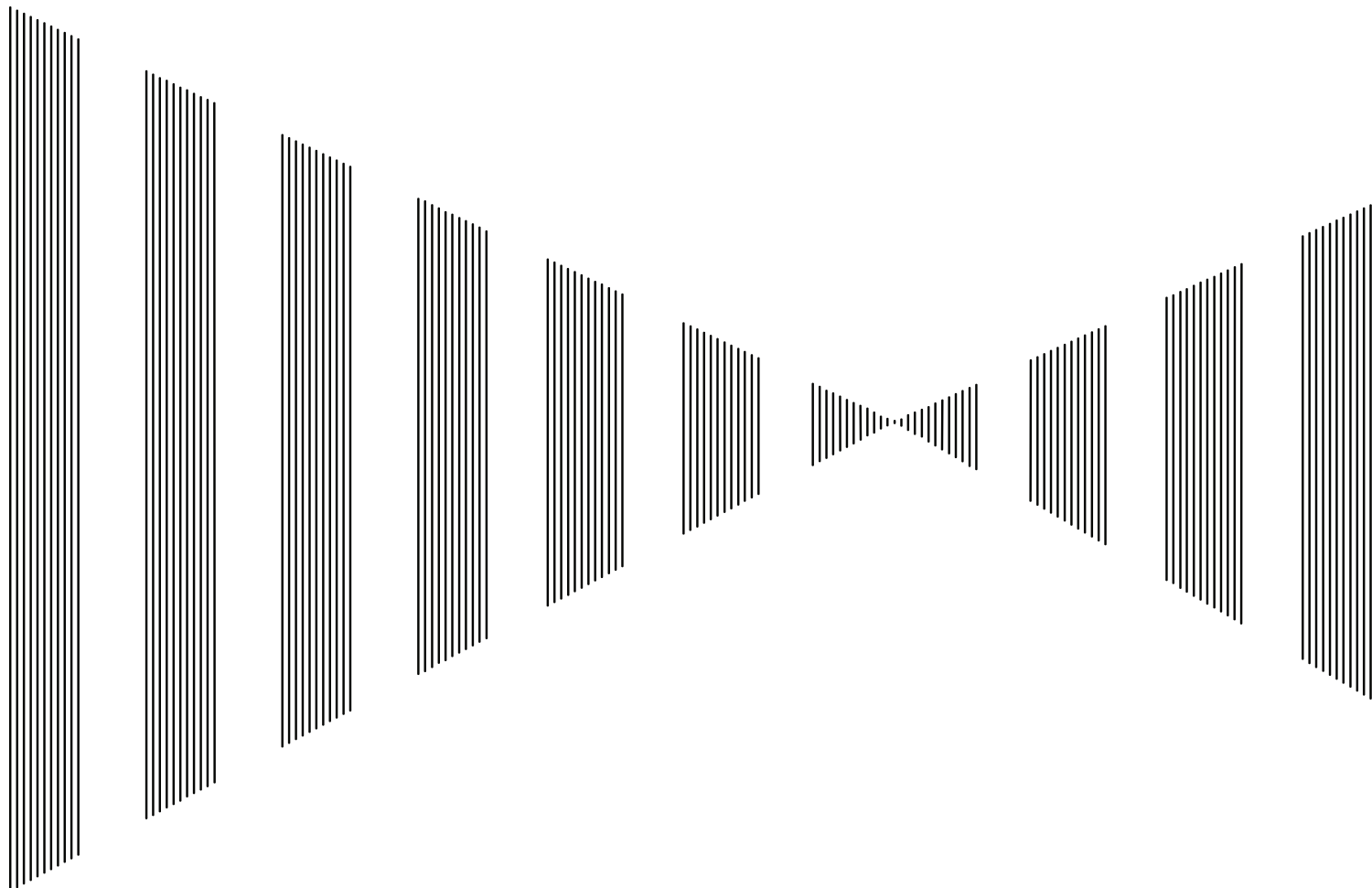



# **INTERSWITCH (OPTION)**

## **NQE-3141**

### **INSTRUCTION MANUAL**

<b>I</b>	<b>OVERVIEW.....</b>	<b>A-1</b>
	<b>I-I OVERVIEW .....</b>	<b>A-1</b>
	<b>I-II INTERSWITCH SETUP .....</b>	<b>A-1</b>
<b>II</b>	<b>INTERSWITCH OPERATION .....</b>	<b>A-2</b>
	<b>II-I OPERATION FLOW.....</b>	<b>A-2</b>
	<b>II-II INTER SWITCH MENU.....</b>	<b>A-3</b>
	<b>II-III CHANGE OF CONNECTION PATTERN (WITH 2 DISPLAY UNITS)</b> <b>.....</b>	<b>A-6</b>
	<b>II-IV CHANGE OF CONNECTION PATTERN</b> <b>(WITH 3 OR MORE DISPLAY UNITS) .....</b>	<b>A-6</b>
	<b>II-V OPERATING CONNECTION PATTERN FILES (FILE OPERATIONS)</b> <b>.....</b>	<b>A-7</b>
	<b>II-VI NAMES OF DISPLAY UNITS AND SCANNER UNITS.....</b>	<b>A-8</b>
<b>III</b>	<b>REFERENCE.....</b>	<b>A-9</b>

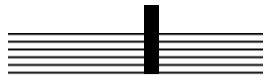

# OVERVIEW

## I-i Overview

Interswitch NQE-3141 is equipment that enables free changeover between radar display units installed on the bridge and antenna units having different characteristics.

If display unit is turned off or malfunctioned, the scanner unit can be controlled by other display unit.

If interswitch unit had malfunctioned, the radar system is switched to standalone mode.

Up to 8 units can be changed over.

When the connected scanner is changed, following setting values are automatically loaded.

Tune Adjustment	(See the section 7.1.3)
Bearing Adjustment	(See the section 7.1.4)
Range Adjustment	(See the section 7.1.5)
Antenna Height	(See the section 7.1.8)
Antenna installation location	(See the section 7.1.9)
Sector Blank	(See the section 7.2.2)
TNI Blank	(See the section 7.2.3)
Performance monitor adjustment	(See the section 7.2.4)
PRF Fine Tuning	(See the section 3.8.3)

## I-ii Interswitch Setup

Connection modes can be changed simply by changing the interswitch connection (upper left of the display ⑥ on page 2-16).

**Note:** A master display unit is always necessary for establishing a slave connection.

Before a slave display unit can be placed in transmission state, the master display unit must be placed in transmission state.

### upper left of the display

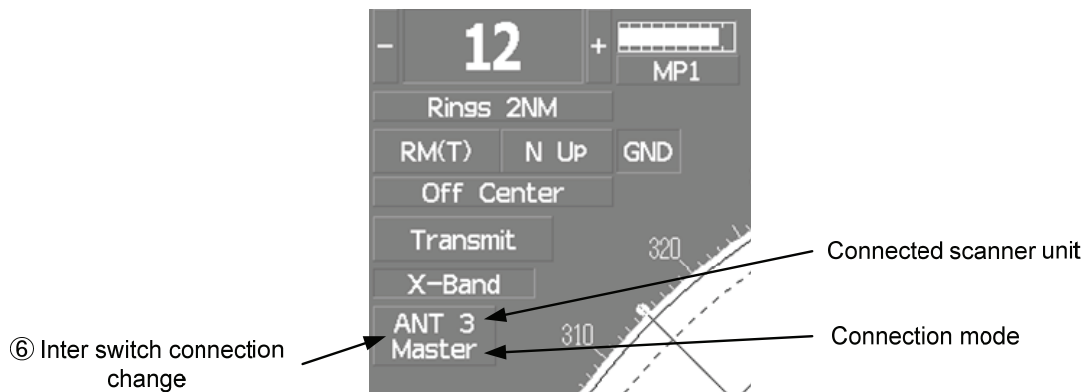

The upper stand indicates the number of the connected scanner unit.

The lower stand indicates the connection mode.

**Master** : Mode in which the scanner unit can be controlled by the display unit.

**Slave** : Mode in which the scanner unit cannot be controlled.

When **Slave** is selected, transmission / standby and pulse length cannot be changed. The available range is also limited.





## INTERSWITCH OPERATION

Follow the flowchart below to change the current interswitch connection pattern.

### II-i Operation Flow

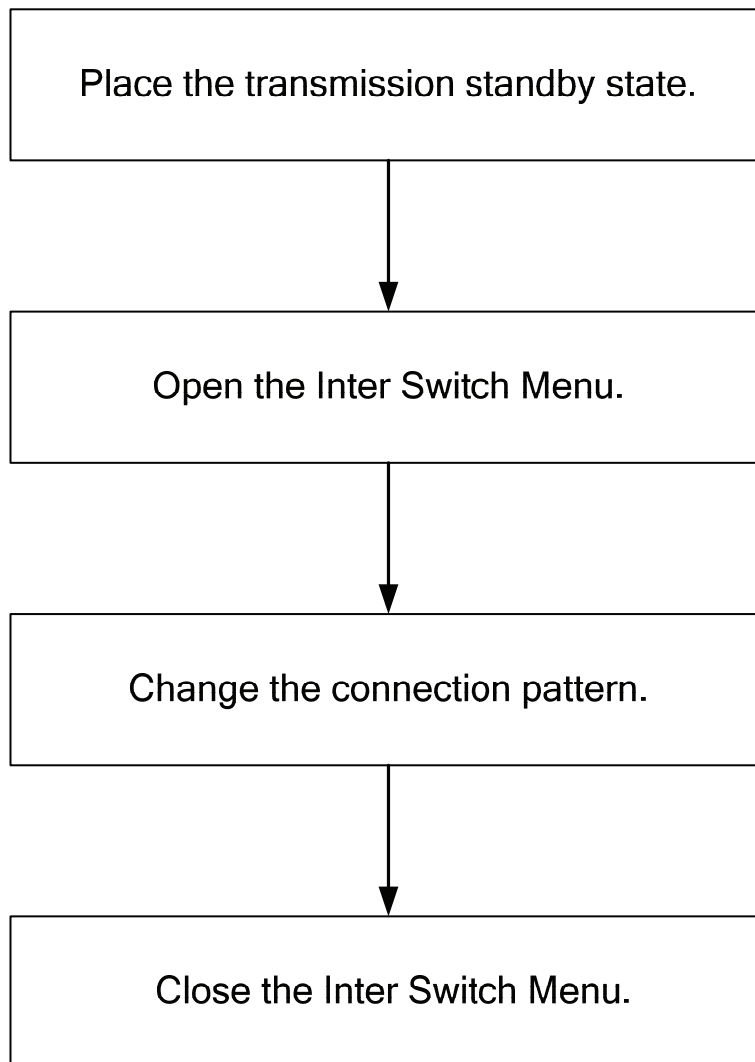

---

## II-ii Inter Switch Menu

The Inter Switch Menu can be opened only when the transmission standby state.

### Procedures

**1 Press the [STBY] key.**

The transmission standby state will be placed.

**2 Move the cursor onto the Interswitch connection change (upper left of the display ⑥ on page 2-16), and press the [ENT] key.**

The Inter Switch Menu will appear.

### Exit

**1 Press the [0] key.**

The Inter Switch Menu will close.

**Inter Switch Menu (with 2 Display Units)**

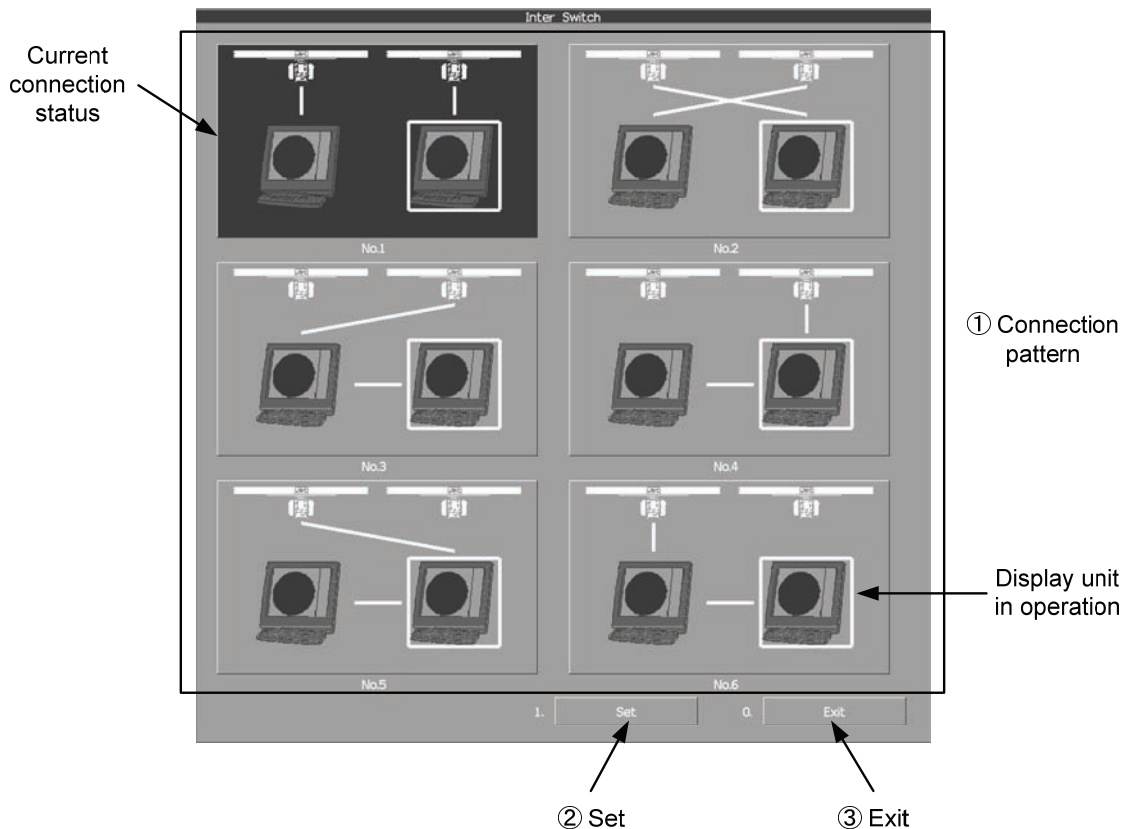

**① : Connection pattern**

If this button is clicked, the connection pattern is selected.  
 The display unit in operation is enclosed in a square □.  
 The background of the current connection pattern display is highlighted.

**② : Set**

If this button is clicked, the change of connection is determined.

**③ : Exit**

If this button is clicked, the Inter Switch Menu is closed .

**Note:** If only 2 display units are installed but the interswitch is set for 3 or more display units, the Inter Switch Menu for 3 or more display units will appear.

## Inter Switch Menu (with 3 or More Display Units)

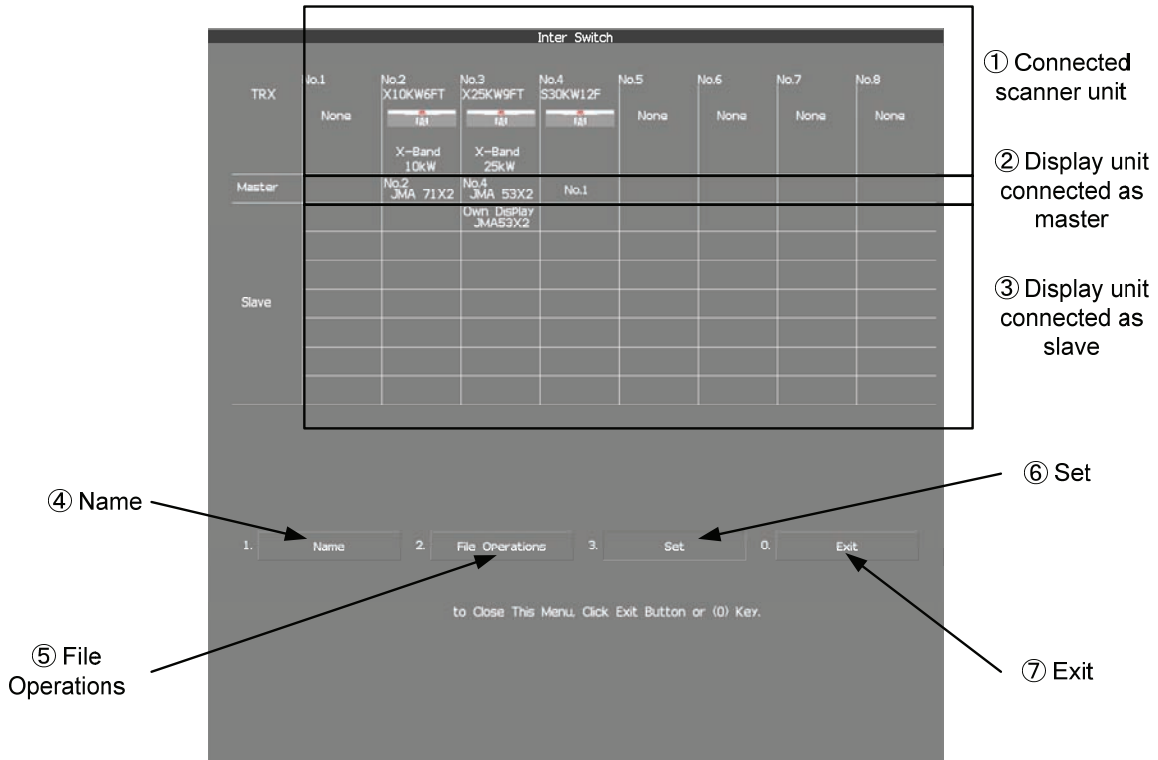

**① : Connected scanner unit**

In mode for naming a display unit or antenna unit, clicking on a unit opens the name input window.

**②, ③ : Display unit connected as master, and Display unit connected as slave**

If this button is clicked, select / cancel the display unit.

If this button is clicked in the naming a display unit or scanner unit mode, the name input window is opened.

**④ : Name**

If this button is clicked, set to the display or scanner unit rename mode.

**⑤ : File Operations**

If this button is clicked, the File Operations menu is opened.

**⑥ : Set**

If this button is clicked, the change of connection is determined.

**⑦ : Exit**

If this button is clicked, the Inter Switch Menu is closed.

### II-iii Change of Connection Pattern (with 2 Display Units)

If two display units are installed, a connection pattern needs to be selected.

#### Procedures

- 1 **Open the Inter Switch menu (with 2 Display Units).**
- 2 **Move the cursor onto the Connection pattern (Inter Switch Menu ① on page A-4) to be changed , and press the [ENT] key.**

The connection pattern will be selected, and  (in Inter Switch Menu ② on page A-4) will blink.

- 3 **Press the [3] key.**

The connection pattern will be changed.

### II-iv Change of Connection Pattern (with 3 or More Display Units)

If three or more display units are installed, the layout of connection patterns needs to be set.

#### Procedures

- 1 **Open the Inter Switch Menu (with 3 or More Display Units).**
- 2 **Move the cursor onto the display unit (Inter Switch Menu ②/③ on page A-5) to be changed , and press the [ENT] key.**

The selected display unit will be highlighted.  
To deselect the display unit, press the [ENT] key again.

- 3 **Move the cursor to the change-destination display unit, and press the [ENT] key.**

The selected display unit in step 2 will be switched to the change-destination display unit, and  (Inter Switch Menu ⑥ on page A-5) will blink.

If the change destination is empty, control will move and  will blink.

- 4 **Press the [3] key.**

The connection pattern will be changed.

**Note:** A master display unit is always necessary for establishing a slave connection.

---

## II-v Operating Connection Pattern Files (File Operations)

Frequently used connection patterns can be read easily by saving interswitch connection patterns.

### [I] Loading connection patterns (Load)

#### **Procedures**

**1 Open the Inter Switch Menu (with 3 or More Display Units).**

**2 Press the [2] key.**

The File Operations menu will appear.

**3 Press the [1] key.**

Currently saved connection patterns in memory will be listed.

**4 Press the [numeric] key corresponding to the file to be loaded.**

Confirmation Window will appear.

**5 Press the [1] key.**

The connection pattern will be changed.

### [II] Saving connection patterns (Save)

#### **Procedures**

**1 Open the Inter Switch Menu (with 3 or More Display Units).**

**2 Press [2] key.**

The File Operations window will appear.

**3 Press [2] key.**

The Save menu will appear.

Currently saved connection patterns in memory will be listed.

**4 Press the [numeric] key corresponding to the file to be saved.**

The Input File Name window will appear.

**5 Enter the file name to be saved.**

Up to 8 characters can be entered.

For the input method on the character input screen, see Section 3.3.4.

The connection pattern will be saved when the name is input.

**[[III]] Erasing a connection pattern (Erase)****Procedures****1 Open the Inter Switch Menu (with 3 or More Display Units).****2 Press the [2] key.**

The File Operations window will appear.

**3 Press the [3] key.**

The Erase menu will appear.

The list of connection patterns stored in the memory will be displayed.

**4 Press the [numeric] key corresponding to the file to be erased.**

Confirmation Window will appear.

**5 Press the [1] key.**

The selected connection pattern is erased and the file name is deleted from the list.

**II-vi Names of Display Units and Scanner Units**

The display units and antenna units can be named.

**Procedures****1 Open the Inter Switch Menu (with 3 or More Display Units).****2 Press the [1] key.**

"Name" will be highlighted, indicating that the rename mode is activated.

**3 Move the cursor to the display unit or scanner unit to be renamed (Inter Switch Menu ① / ② / ③ on page A-5), and press the [ENT] key.**

The Input IND Name or the Input TXRX Name window will appear.

**4 Input a new unit name.**

Up to 8 characters can be input as a unit name.

For the input method on the character input menu, see Section 3.3.4.

The selected display unit or antenna unit will be renamed when the new name is input.



## REFERENCE

### Preheat Time after Change of Connection Pattern

After the current interswitch connection pattern has been changed, operation needs to wait until the system is ready. This is because the preheat time varies depending on the previous connection of the scanner unit and display unit.

The wait time is necessary for protecting the electronic tubes that emit radio waves.

- a) When not changed to a new connection pattern : Preheating not required
- b) When changed to a new connection pattern and an scanner unit had been used before the change : Preheating not required
- c) When changed to a new connection pattern and an scanner unit had not been used before the change : Preheating required

### Notes on Changing Connection Pattern

An attempt to change to another connection pattern immediately after the completion of connection pattern change may fail.

This is because internal processing still needs some preparation time upon completion of connection pattern change. Let several seconds pass between connection pattern change operations.

### Notes on Connecting Slave Display Unit

Before a slave display unit can be placed in transmission state, the master display unit must be placed in transmission state. If the master display unit is moved from the transmission state to the transmission standby state, the slave display unit is forcibly placed in transmission standby state.

When they are in transmission standby state,

MTR Standby is shown in the alarm indication (Brilliance / alarm on page 2-9), and the alarm sounds.

A slave display unit cannot control tune. Tune is controlled by the master display unit. Slave is shown in the transmitter pulse length (upper left of the display on page 2-2).

Range change for a slave display unit is limited by the range and pulse length / repetition frequency of the master display unit. As a rule, a greater range than the range of the master display unit cannot be set for a slave display unit. However, if the transmitter pulse length of a slave display unit is identical to the master display unit's and the repetition frequency is within the master display unit's, a greater range than the master display unit's can be selected for the slave display unit. When the master display unit narrows the range or changes the transmitter pulse length, the range of the slave display unit may be forcibly changed. In this case, Master Range CHG is shown in the alarm indication (Brilliance / alarm on page 2-9), and the alarm sounds.



**Setting at Installation**

◎ **Setting of the interswitch circuit (CCL-304\*)**

The settings of the DIP switches SW11 to SW13 are shown below.

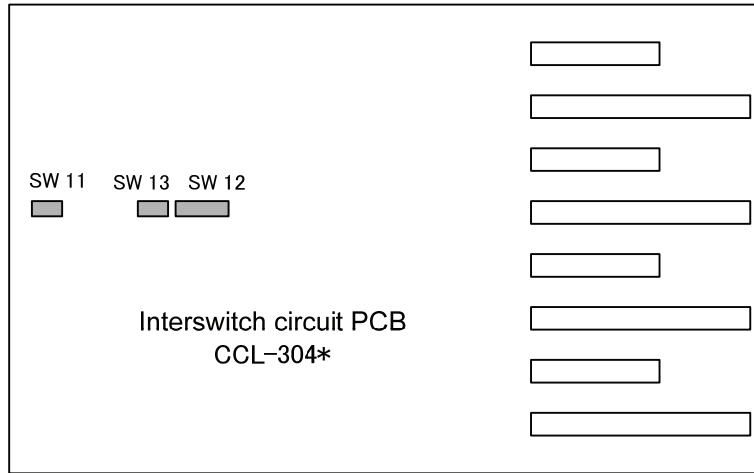

1) SW11 setting (extension mode and master/slave settings)

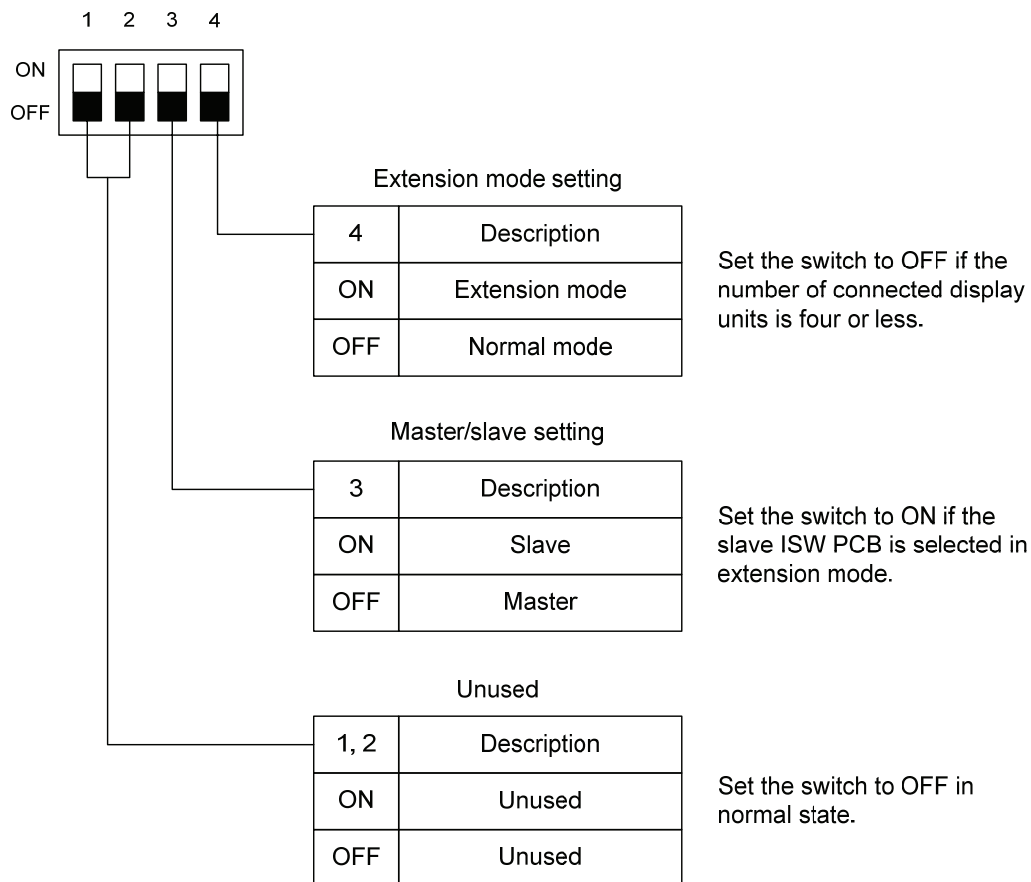

2) SW12 setting (radar connection settings)

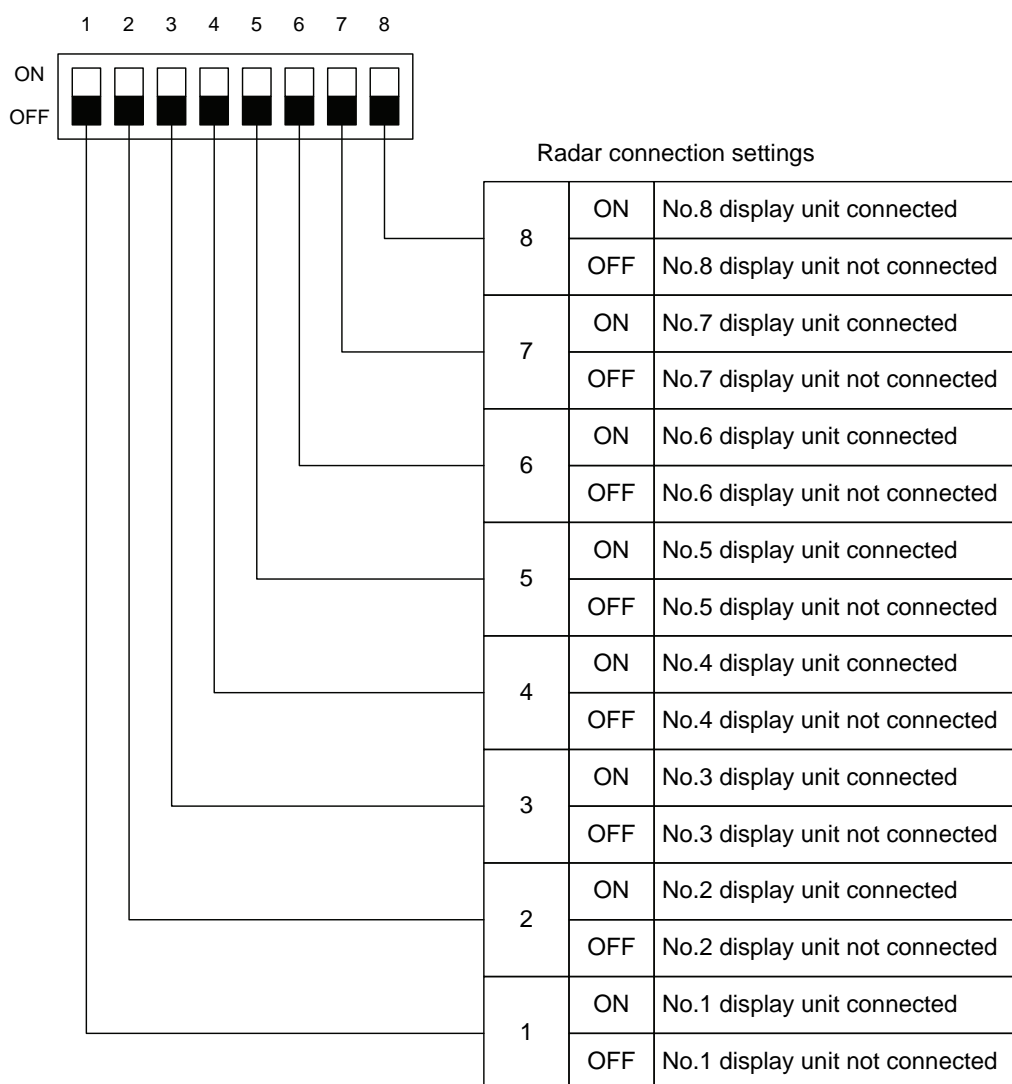

3) SW13 (unused)

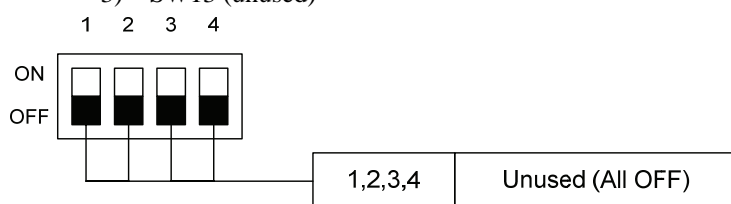

**Note:** Before the DIP switches of the interswitch circuit can be set, the interswitch breaker must be turned off in order to ensure safety operation.

# HOW TO INSERT AND REMOVE A CARD

Insert or remove the JRC coastline ROM card, ERC card, C-MAP card and memory card according to the procedures below.

**Note:** Keep a card horizontal when inserting it into a card slot. An inclined card causes a failure.

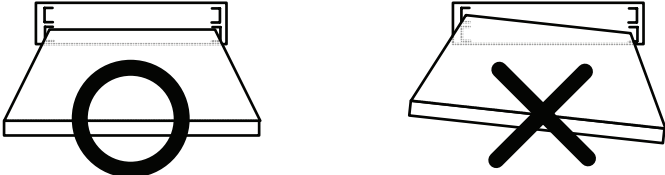

Do not simultaneously insert a JRC coastline ROM card, an ERC card and C-MAP card into the card slot. A malfunction will occur on the display.

Insert the card into the specified slot according to the following table:

Card type	Insertion slot No.
JRC card	Either one
ERC card	Either one
C-Map NT+ detail card	Either one
Memory card	Either one

**Note:** The Background of C-Map has been built in, don't insert C-Map NT+ background card. If the background card is inserted, the system will malfunction.

## Insert a card into processor unit

**Procedures**

- 1 Remove the rubber packing located at the backside of the processing unit cabinet, and expose the card slot.

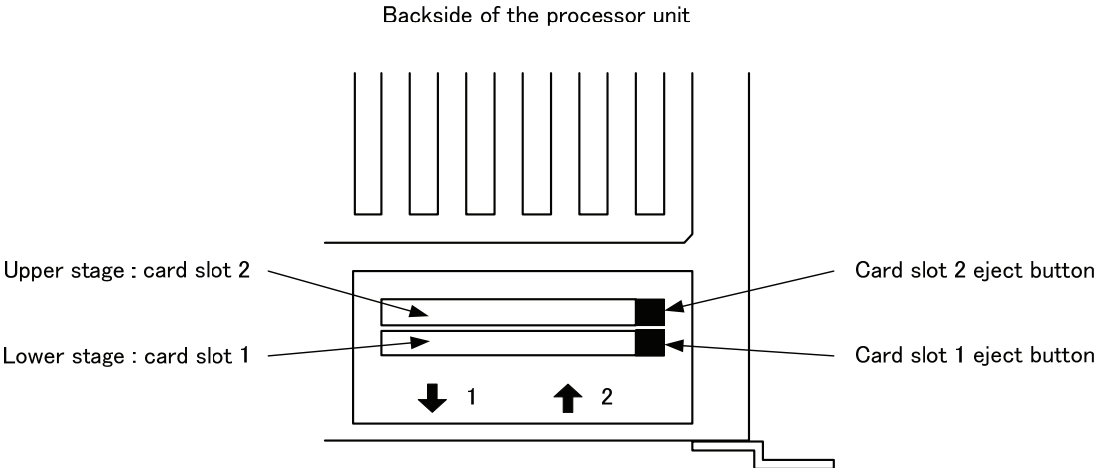

## 2 Insert the card in the direction indicated by the arrow.

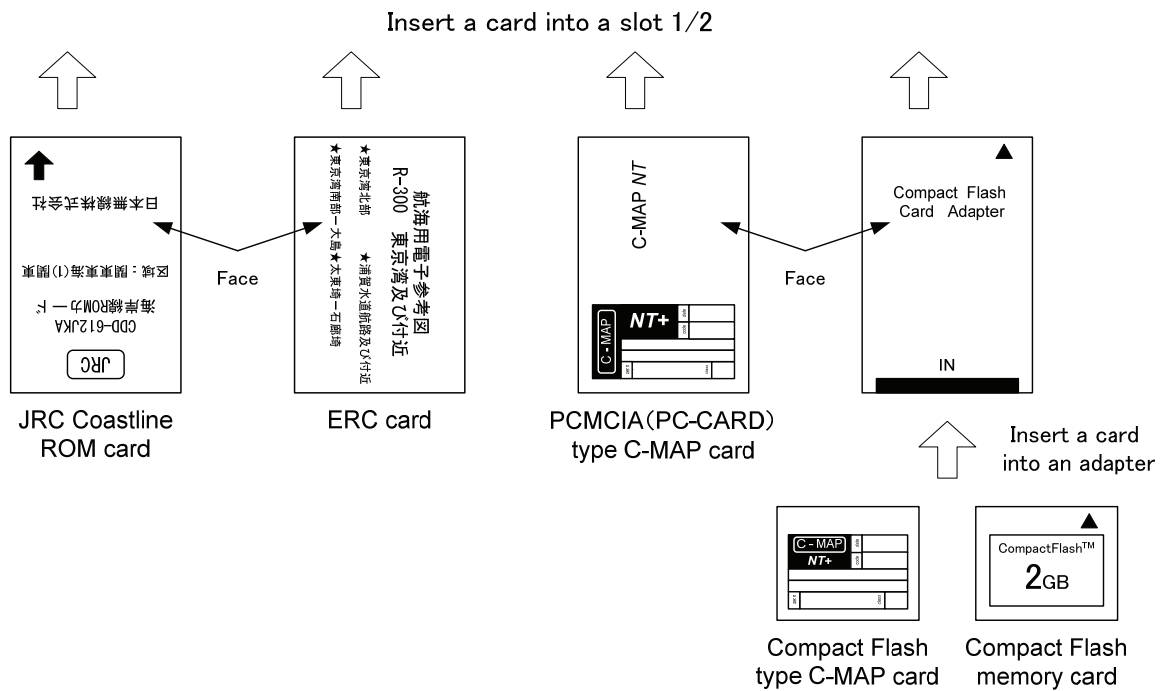

## 3 Insert the card until the card slot's eject button protrudes and complete the installation of a card.

### Eject a card from processor unit

#### **Procedures**

- 1 Push the eject button corresponding to the desired card slot.
- 2 remove a card from processor unit

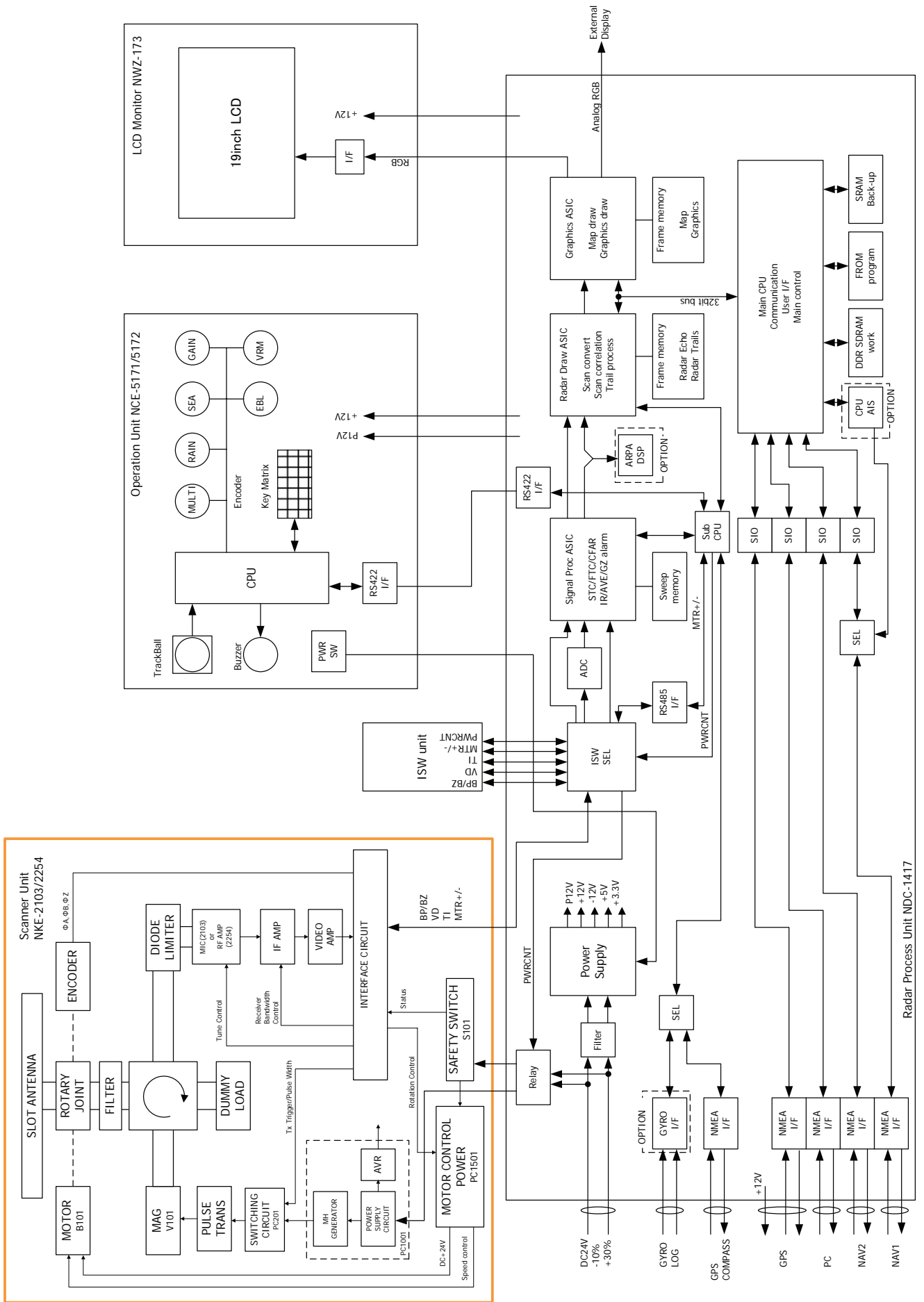

NOTE: Performance monitor, ARPA/ATA Process Unit, AIS Process Unit and GYRO Interface Unit must be fitted on ships compliant to IMO.

付図1 Fig.1  
 JMA-5312-6/6HS,5322-7/9  
 レーダー装置回路動作説明図  
 Block Diagram of RADAR

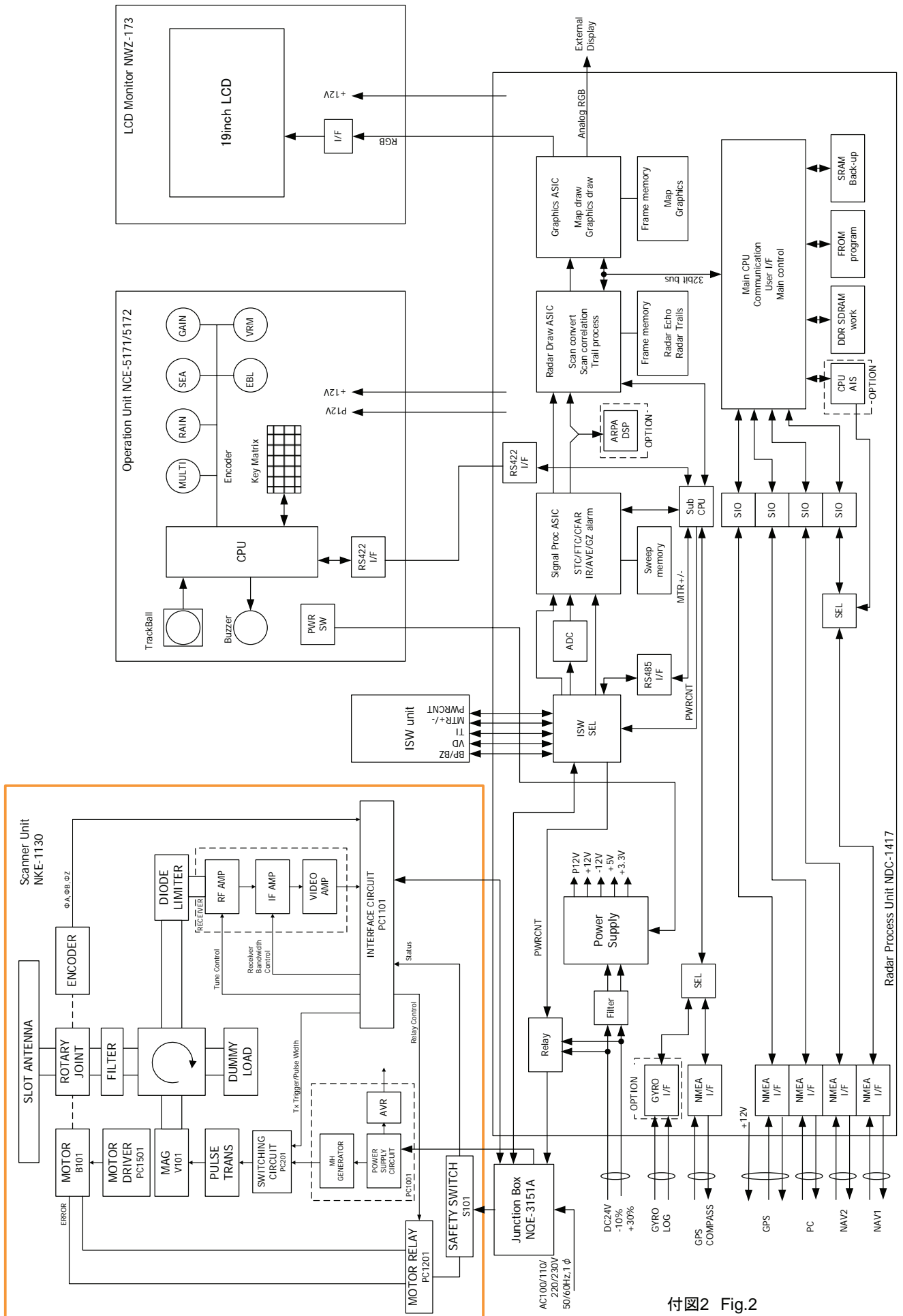

NOTE: Performance monitor, ARPA/ATA Process Unit, AIS Process Unit and GYRO Interface Unit must be fitted on ships compliant to IMO.

付図2 Fig.2  
JMA-5332-12  
レーダー装置回路動作説明図  
Block Diagram of RADAR

# 付図3 Fig.3 JMA-5312-6/6HS 盤間接続図 Terminal Board Connection Diagram

NOTE: Performance monitor must be fitted on ships compliant to IMO.

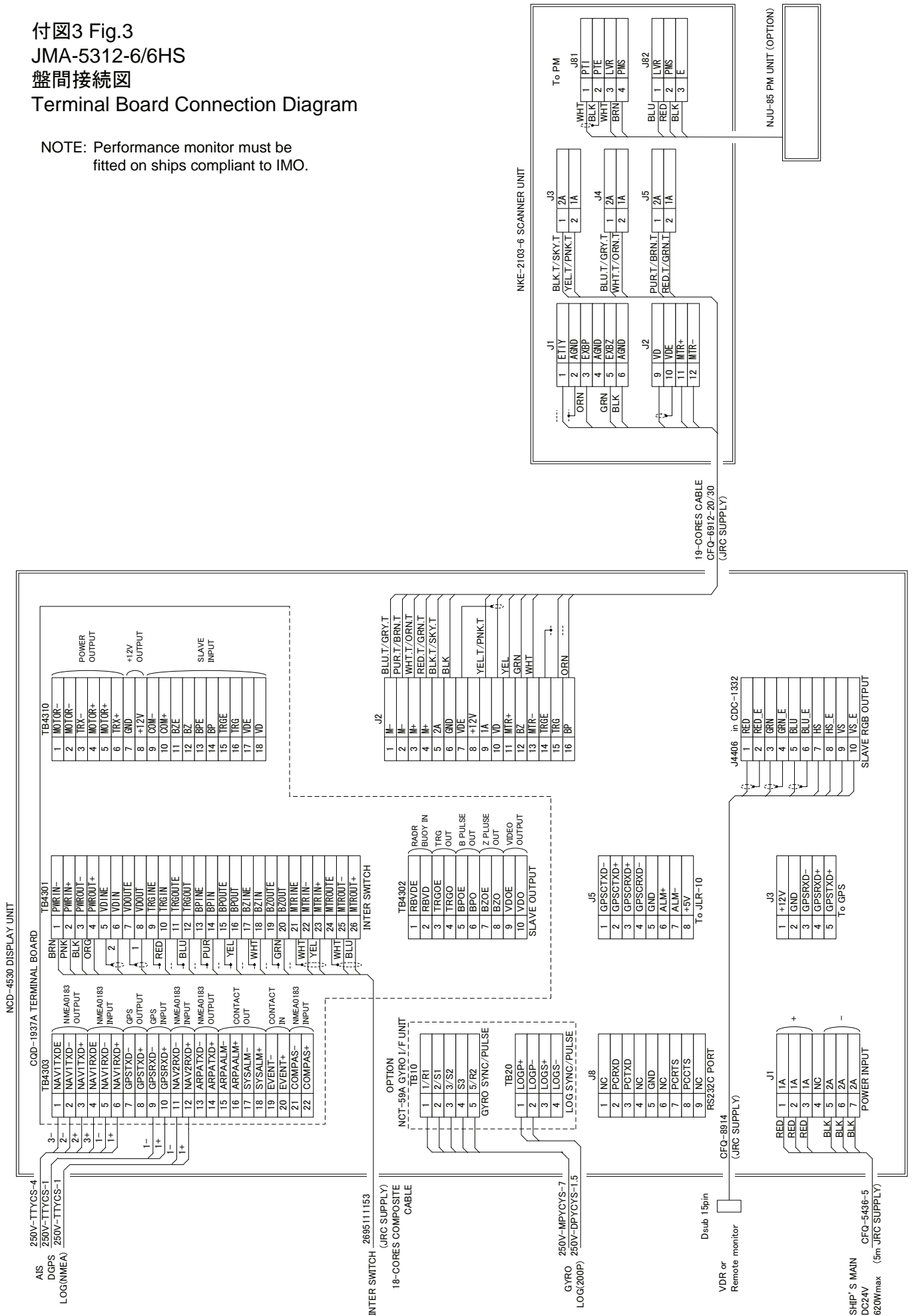

付図4 Fig.4  
 JMA-5322-7/9/6HS  
 盤間接続図  
 Terminal Board Connection Diagram

NOTE: Performance monitor must be fitted on ships compliant to IMO.

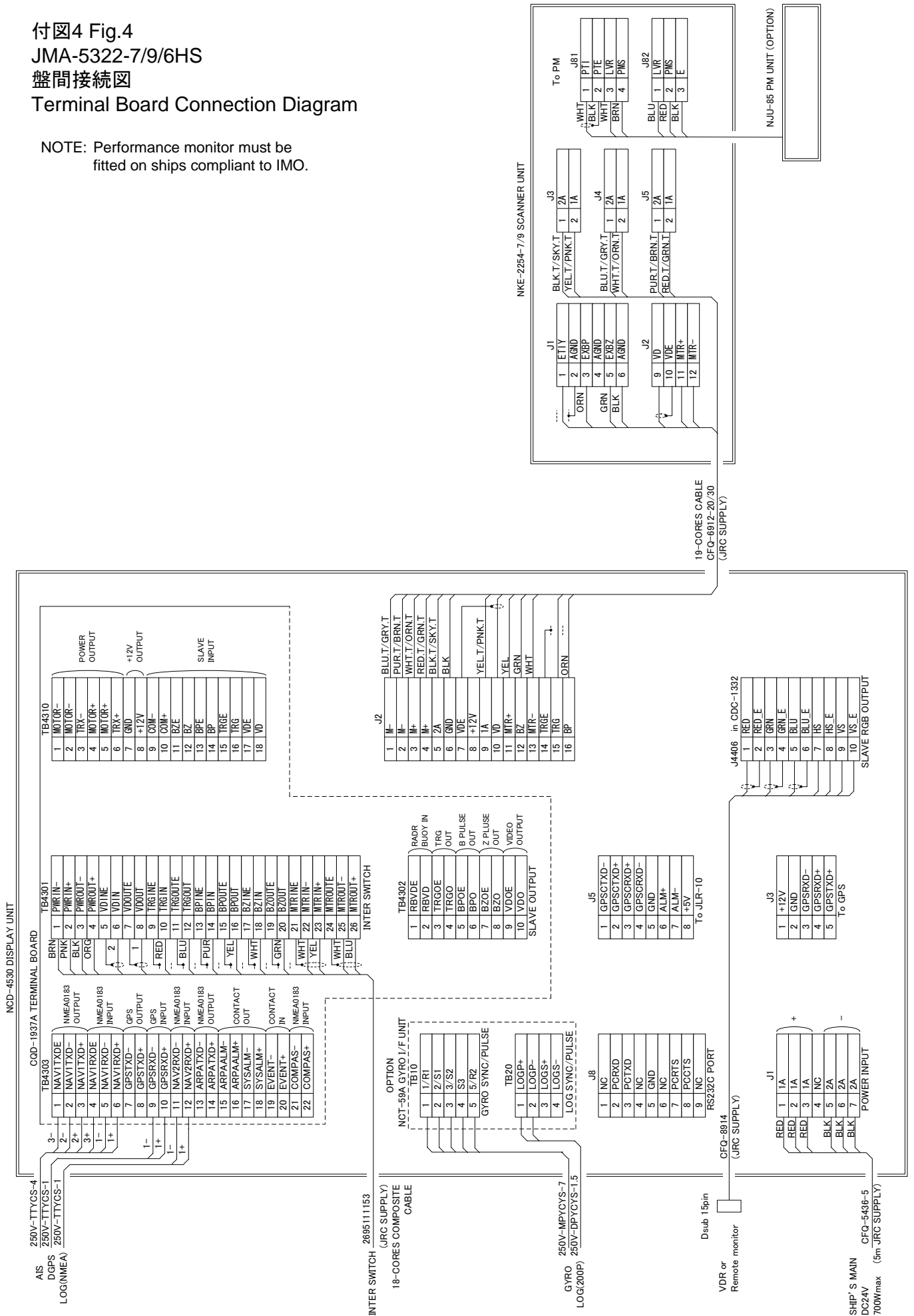



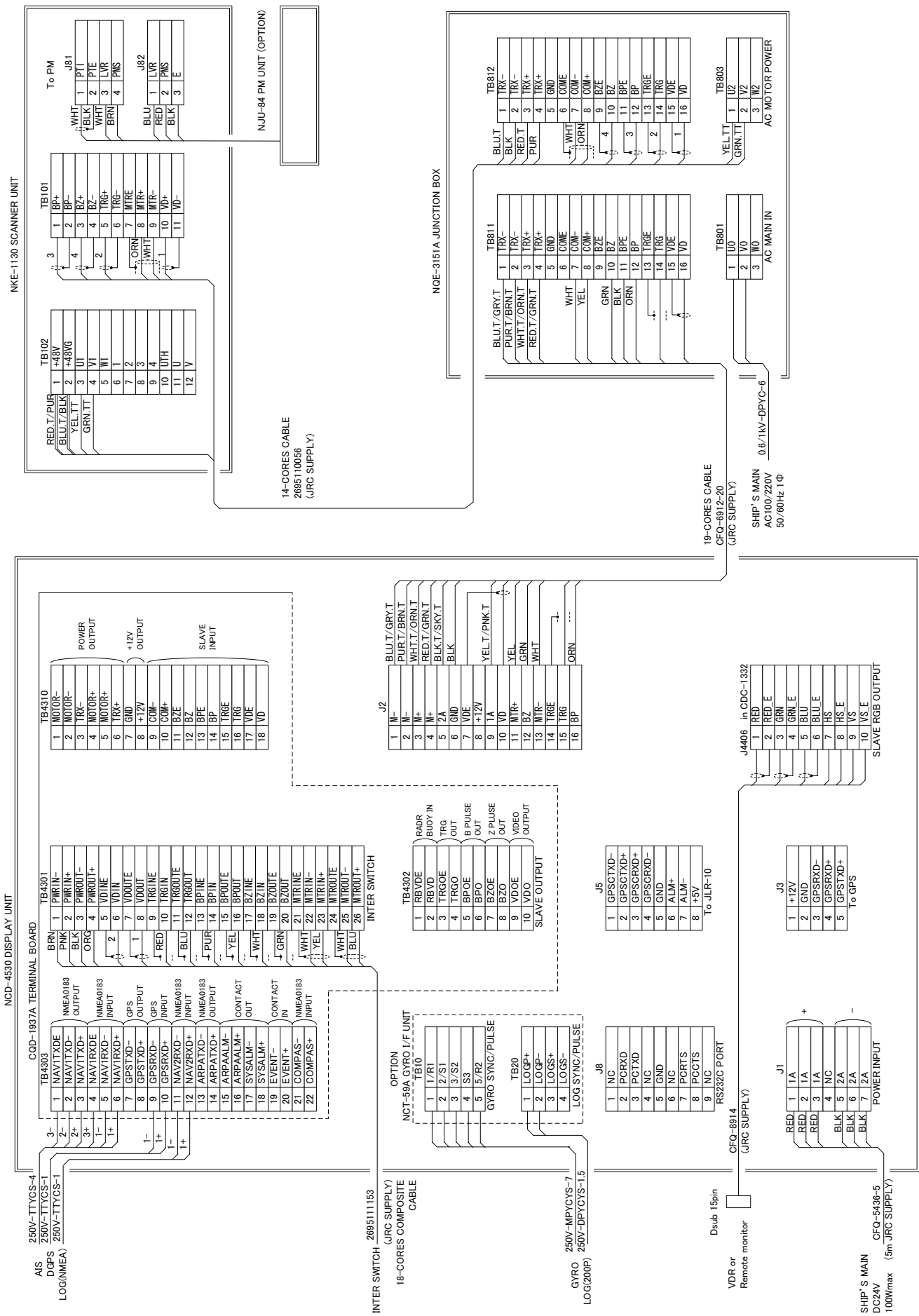

NOTE: Performance monitor must be fitted on ships compliant to IMO.

付図5 Fig.5  
JMA-5332-12  
盤間接続図  
Terminal Board Connection Diagram

NQE-3141-4A INTER-SWITCH UNIT

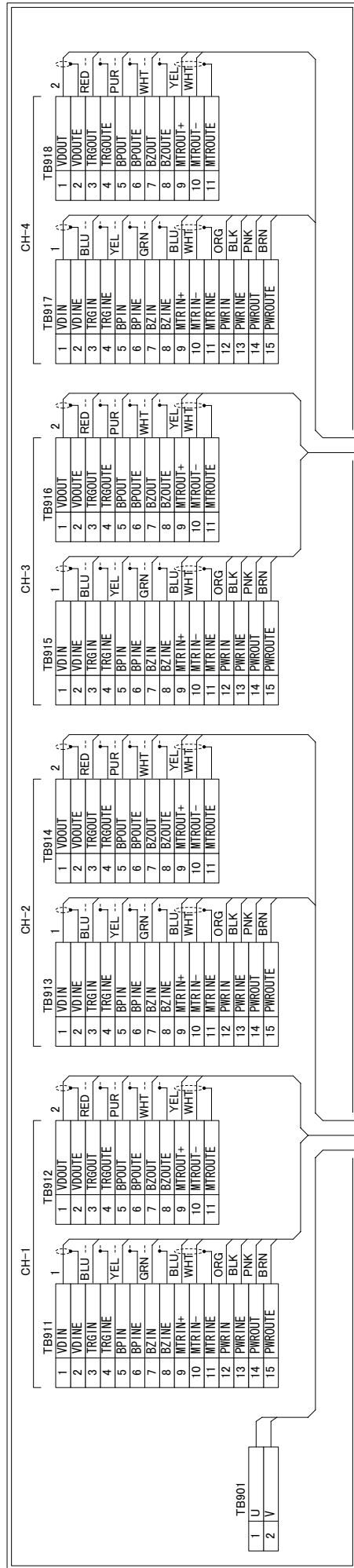

SHIP'S MAIN  
AC100-240V  
50/60Hz 1Φ  
30VAmx

0.6/1KV-DPYC-1.5

269511153 (JRC SUPPLY)  
18-CORES COMPOSITE CABLE

269511153 (JRC SUPPLY)  
18-CORES COMPOSITE CABLE

269511153 (JRC SUPPLY)  
18-CORES COMPOSITE CABLE

269511153 (JRC SUPPLY)  
18-CORES COMPOSITE CABLE

JMA-5300MK2 Series RADAR

JMA-5300MK2 Series RADAR

JMA-5300MK2 Series RADAR

JMA-5300MK2 Series RADAR

JMA-5300MK2 Series RADAR

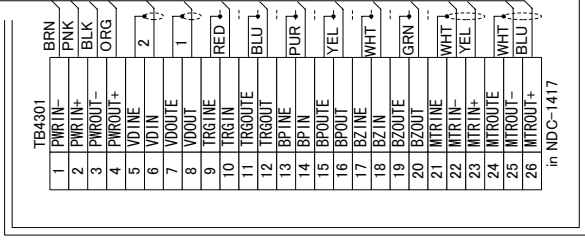
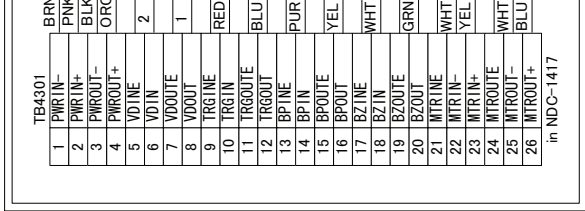
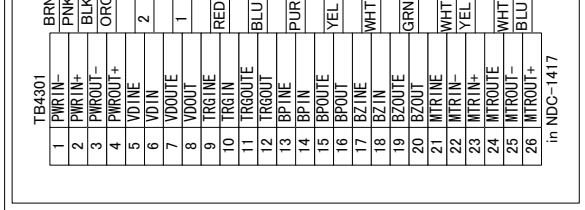
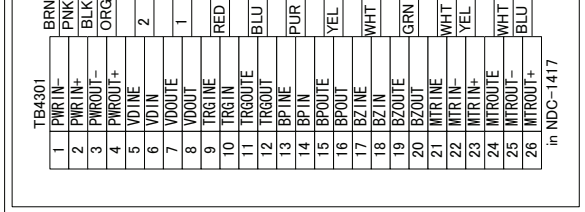

付図6 Fig.6

NQE-3141

インタースイッチユニット盤間接続図  
Terminal Board Connection Diagram of  
Radar and Interswitch Unit

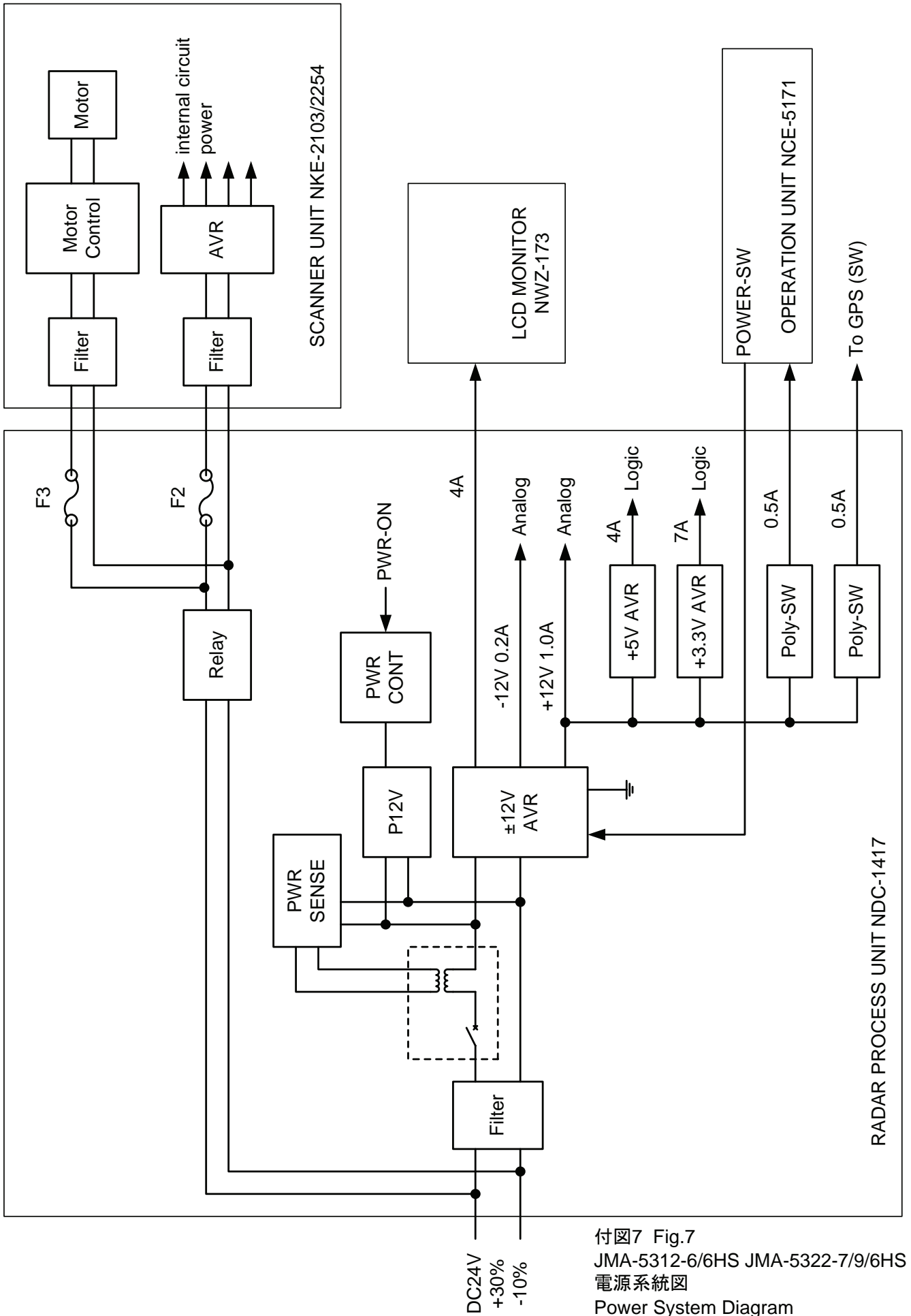

付図7 Fig.7  
 JMA-5312-6/6HS JMA-5322-7/9/6HS  
 電源系統図  
 Power System Diagram

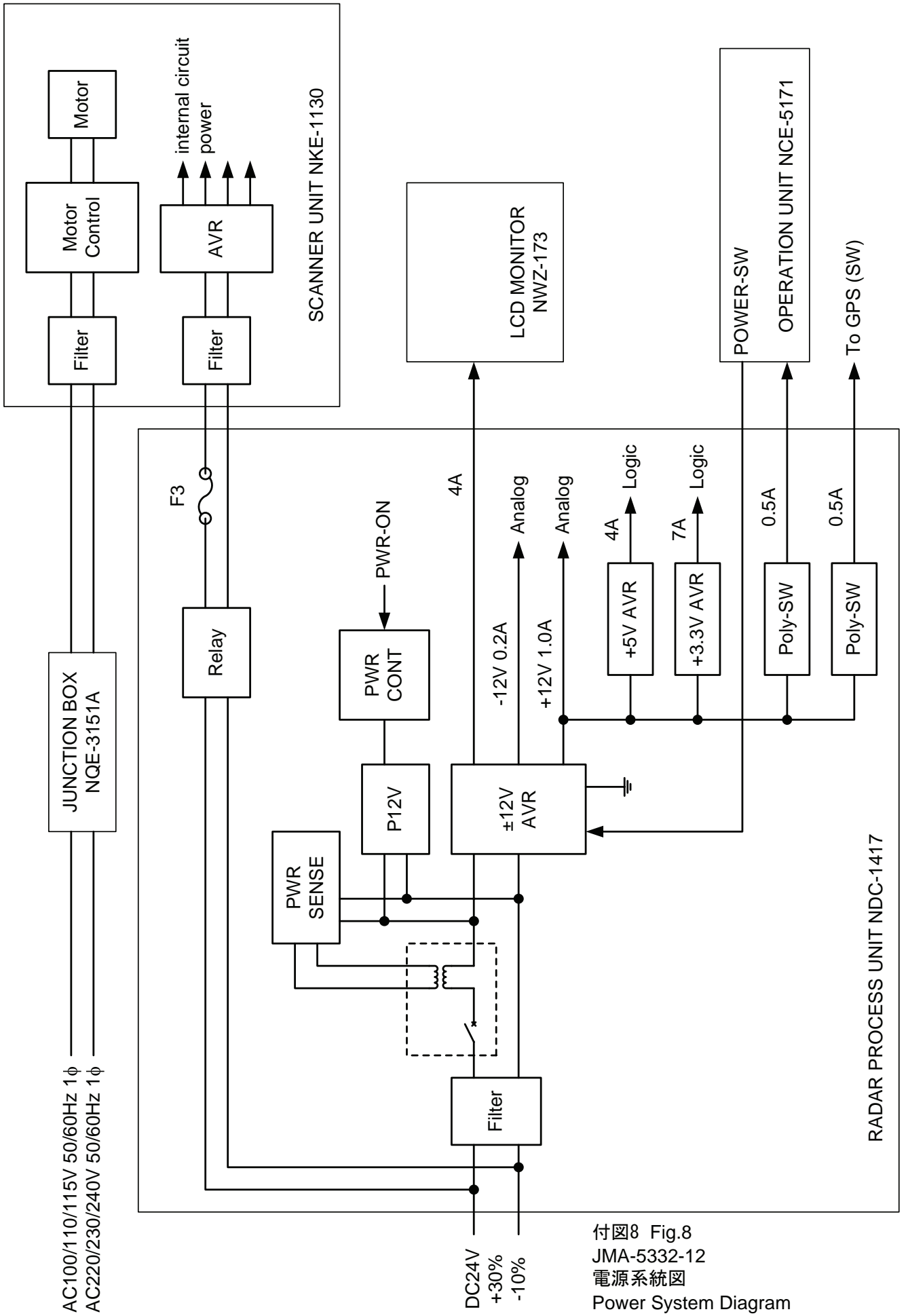

付図8 Fig.8  
 JMA-5332-12  
 電源系統図  
 Power System Diagram

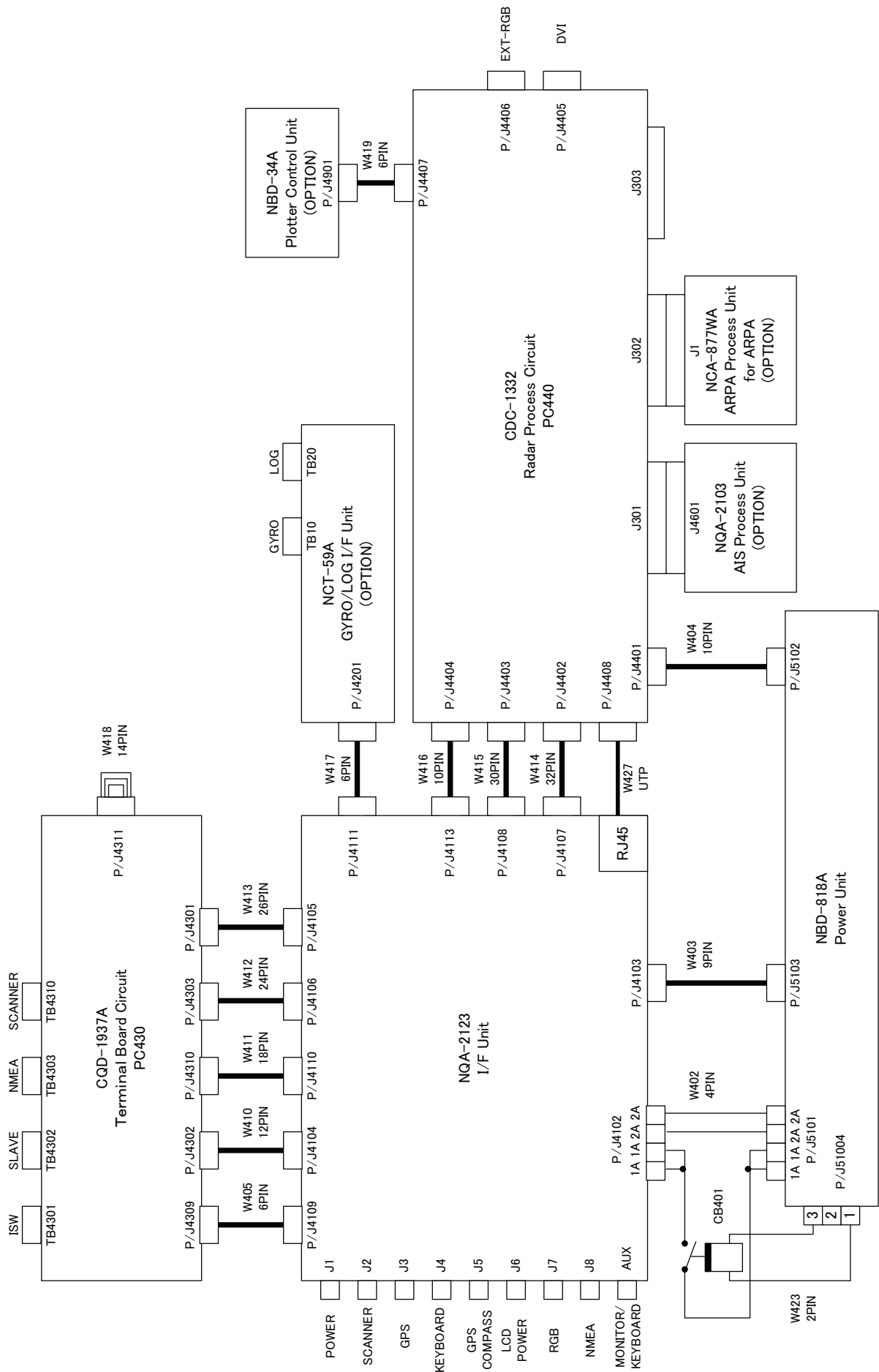

NOTE: ARPA/ATA Process Unit, AIS Process Unit and GYRO Interface Unit must be fitted on ships compliant to IMO.

付図9 Fig.9  
NDC-1417  
処理部機内接続図  
Interconnection Diagram of Radar Process Unit

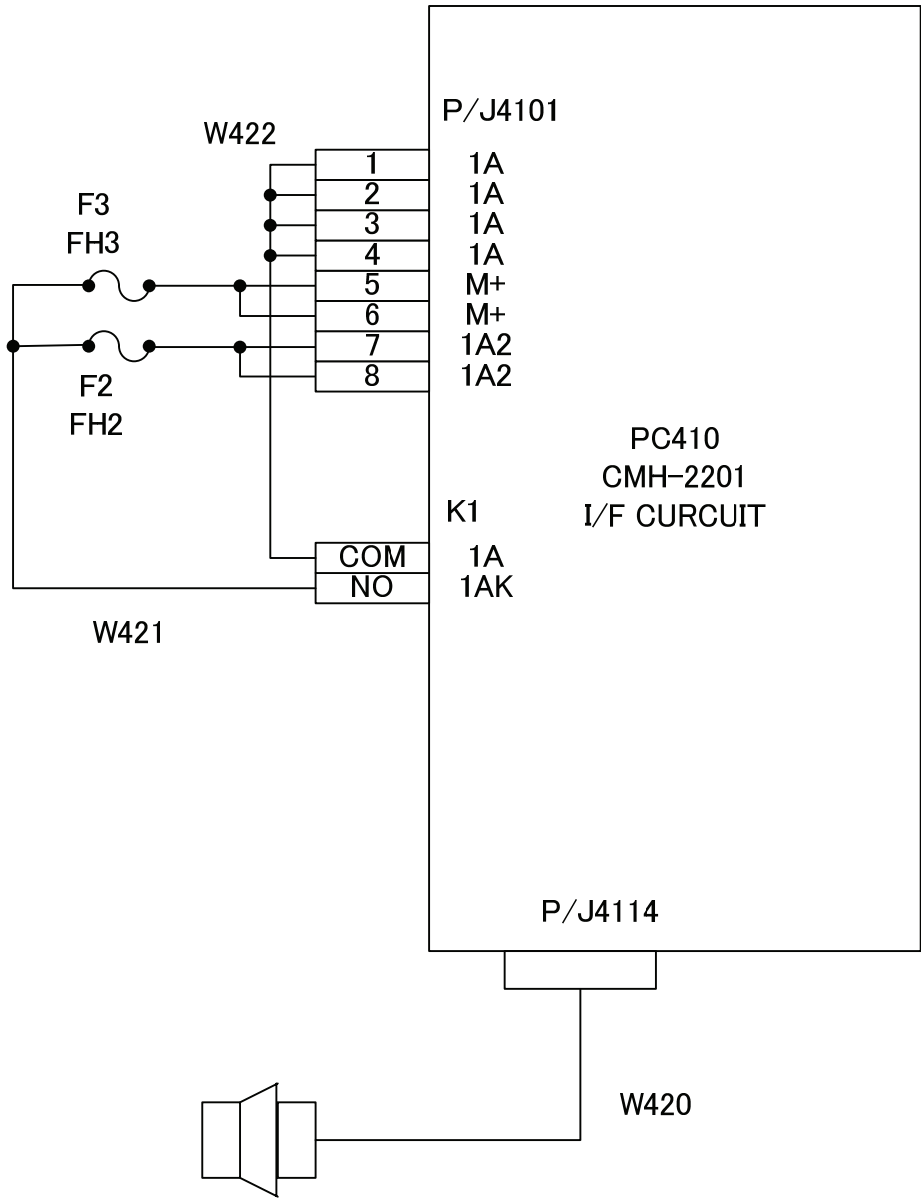

付図10 Fig.10  
 NQA-2123  
 入出力部機内接続図  
 Interconnection Diagram of Interface Unit

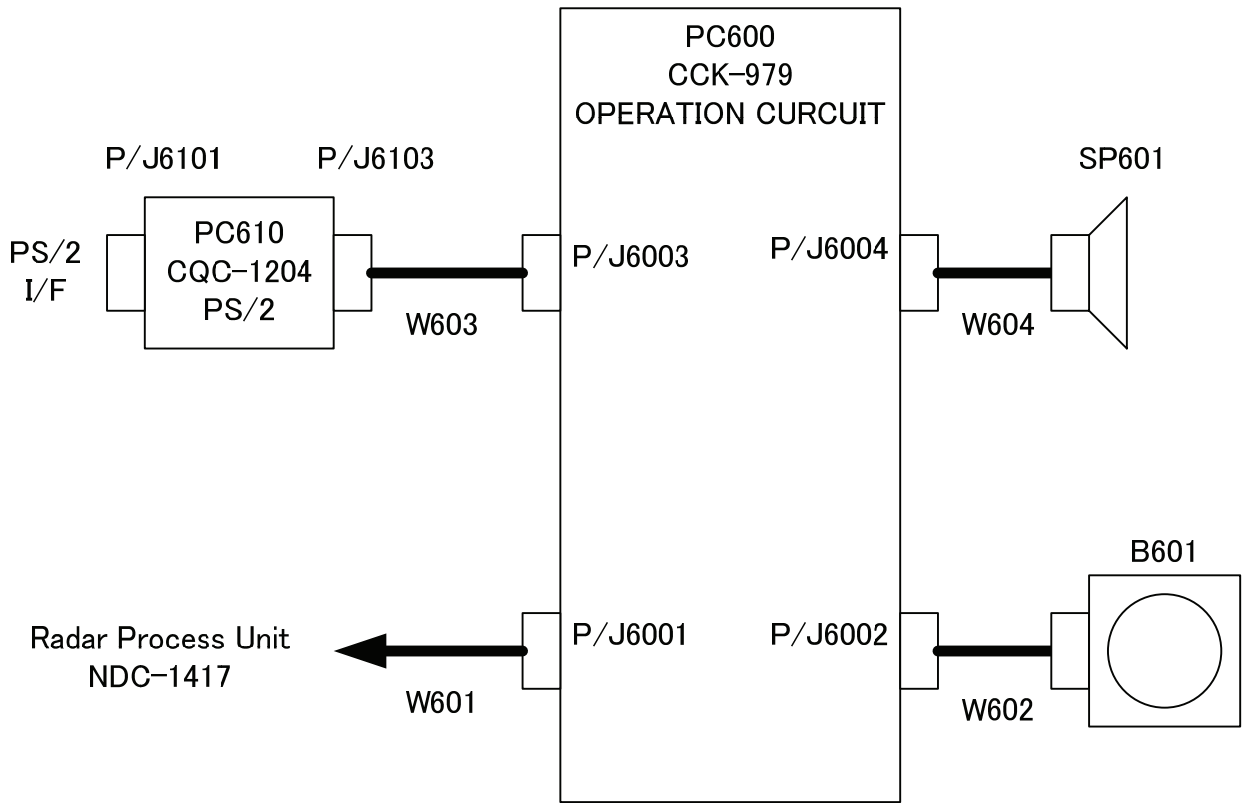

付図11 Fig.11  
 NCE-5171  
 操作部機内接続図  
 Interconnection Diagrams of Operation Unit

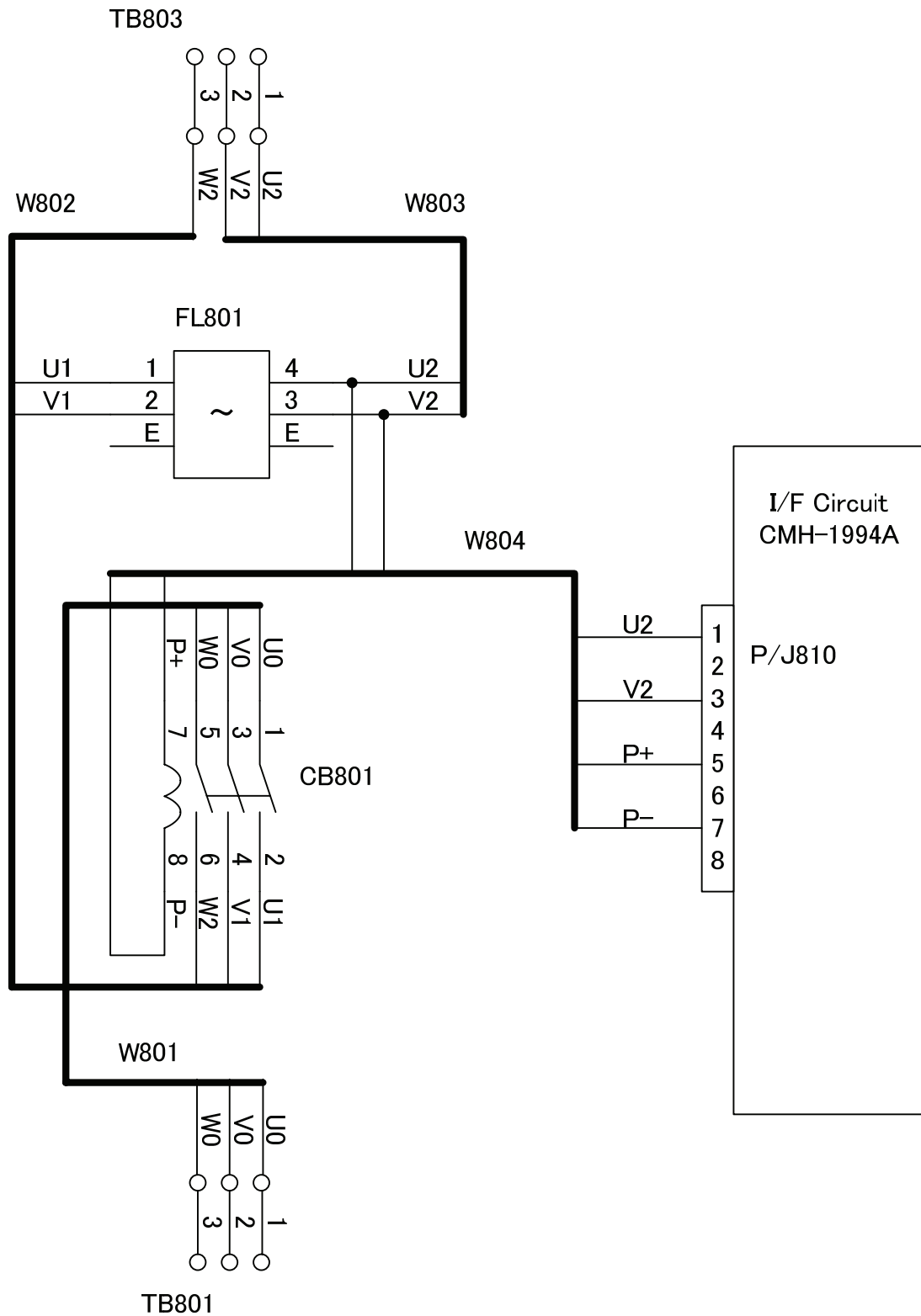

付図12 Fig.12  
 NQE-3151A  
 接続箱機内接続図  
 Interconnection Diagram of Junction Box



NOTE: Performance monitor must be fitted on ships compliant to IMO.

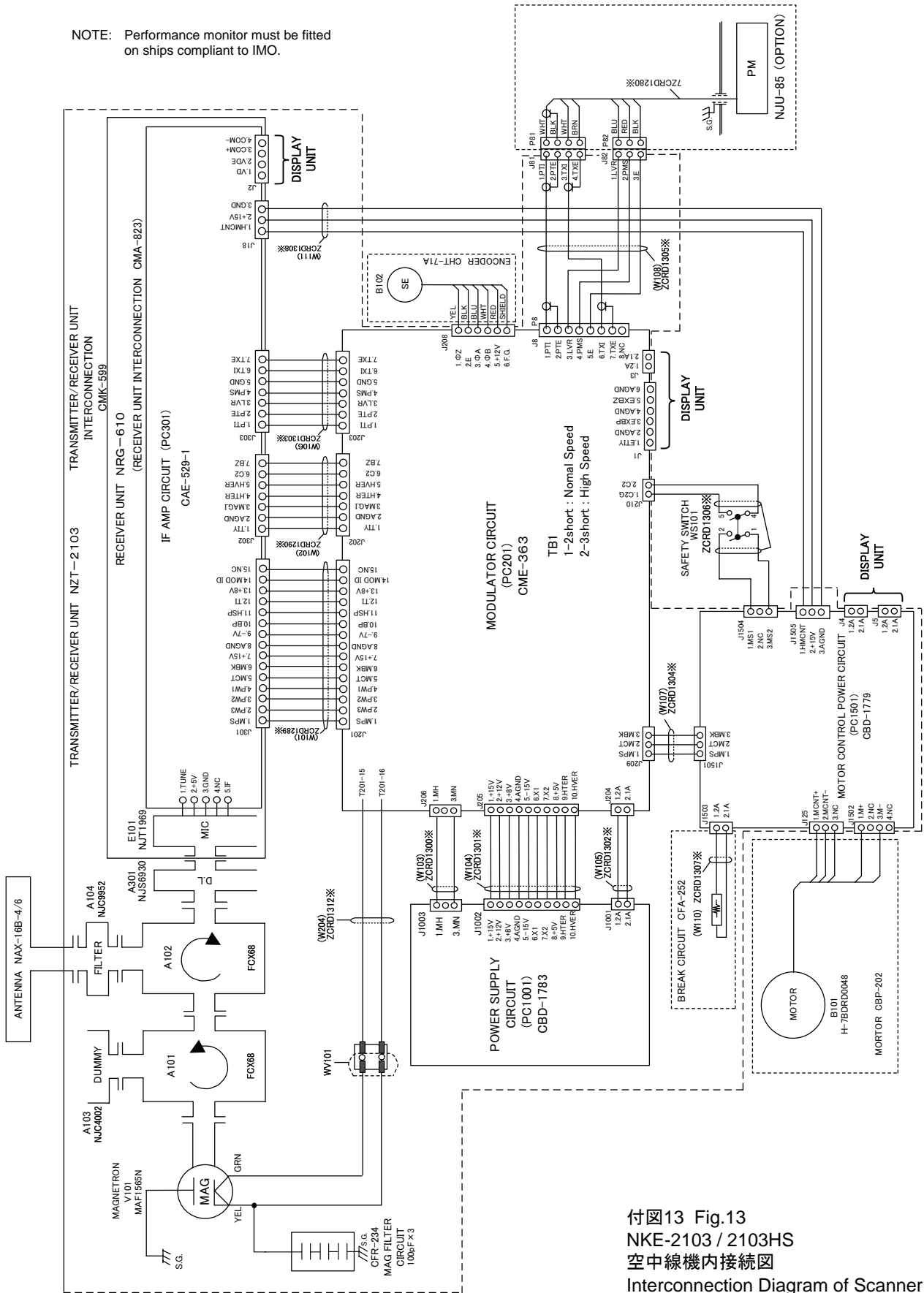

SCANNER UNIT INTERCONNECTION  
CAX-10

付図13 Fig.13  
NKE-2103 / 2103HS  
空中線機内接続図  
Interconnection Diagram of Scanner Unit

付図14 Fig.14  
 NKE-2254  
 空中線機内接続図  
 Interconnection Diagram of Scanner Unit

NOTE: Performance monitor must be fitted on ships compliant to IMO.

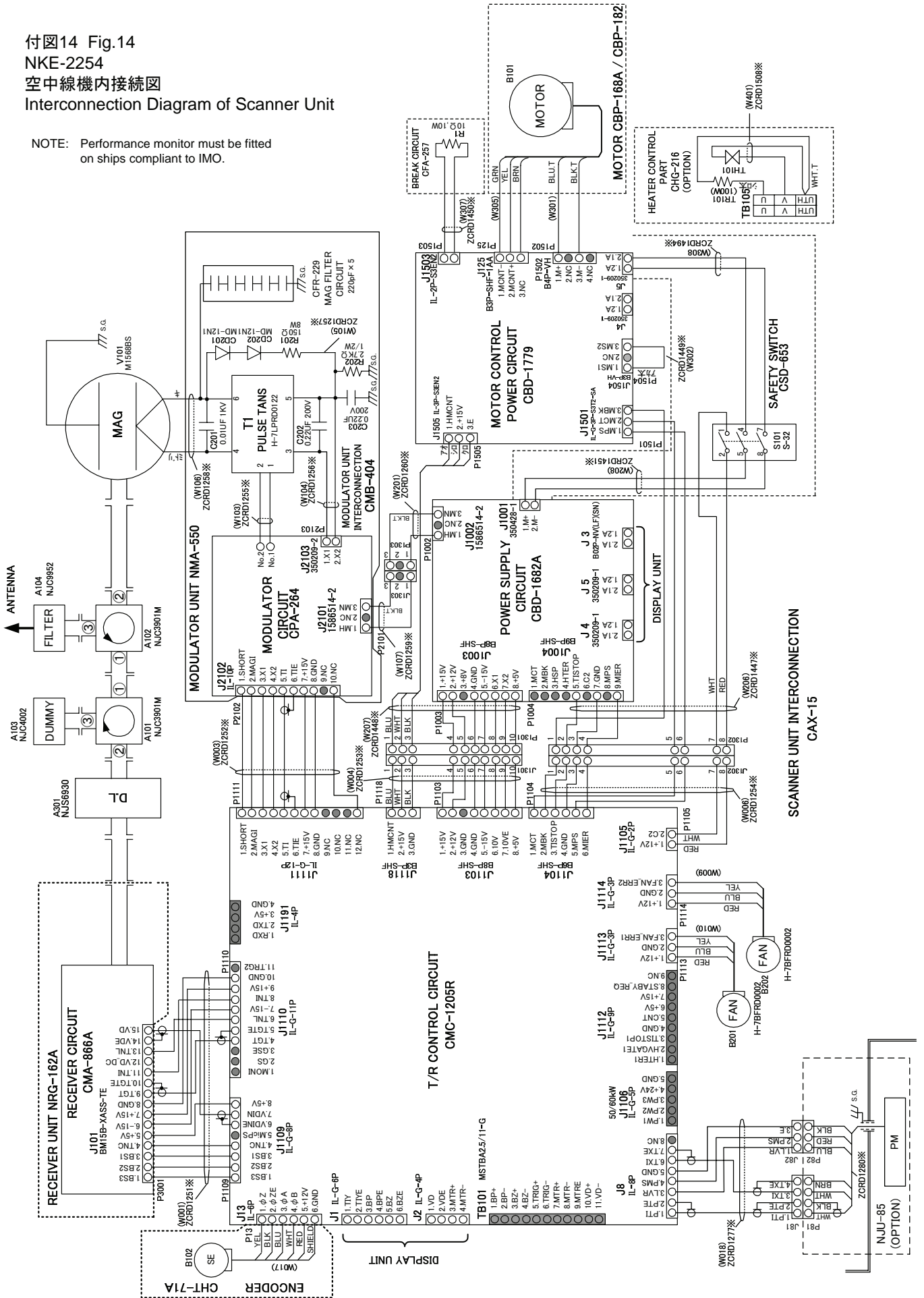

付図15 Fig.15  
 NKE-1130 (AC100/110/115V)  
 空中線機内接続図  
 Interconnection Diagram of Scanner Unit

NOTE: Performance monitor must be fitted on ships compliant to IMO.

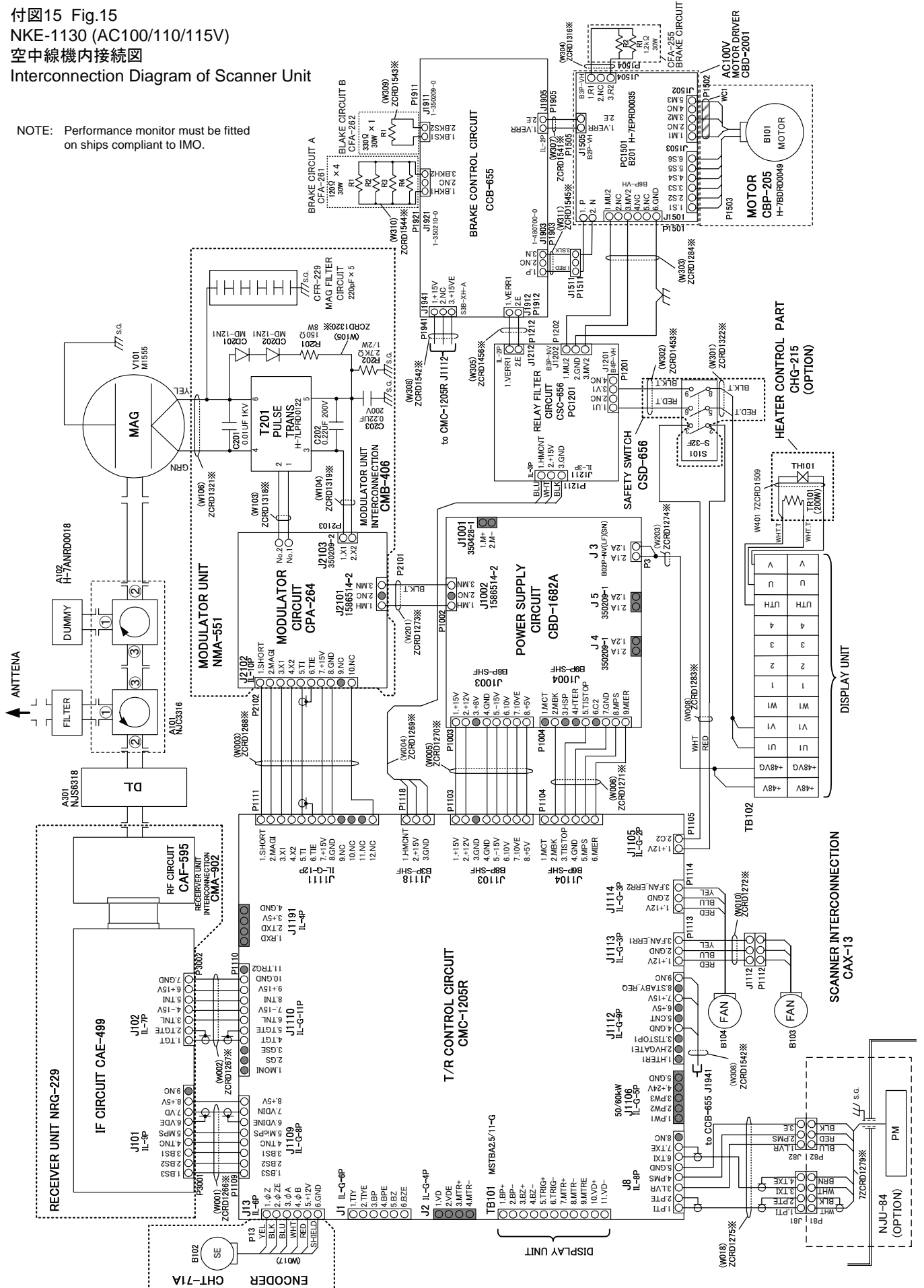

付図16 Fig.16  
 NKE-1130 (AC220/230/240V)  
 空中線機内接続図  
 Interconnection Diagram of Scanner Unit

NOTE: Performance monitor must be fitted on ships compliant to IMO.

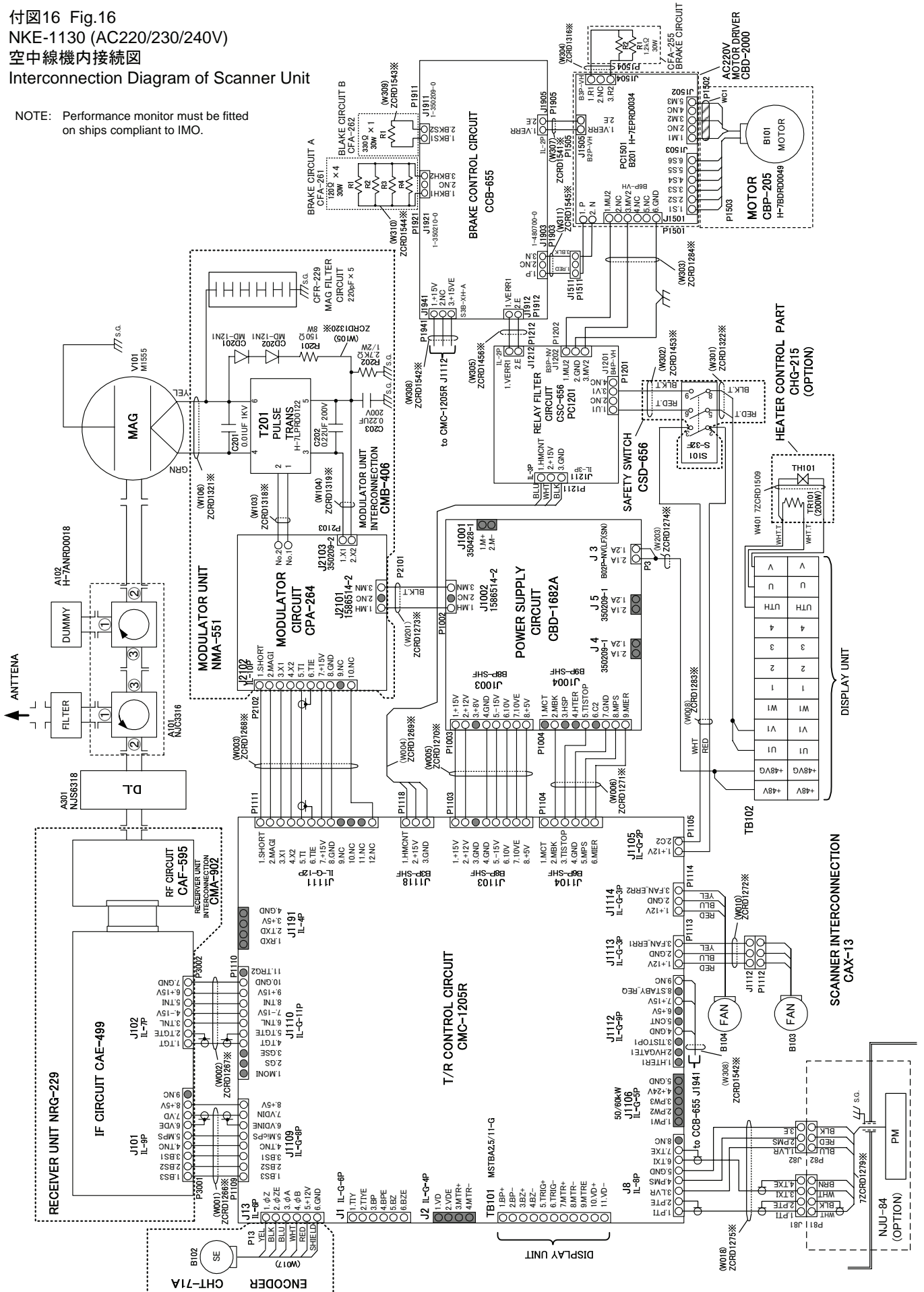

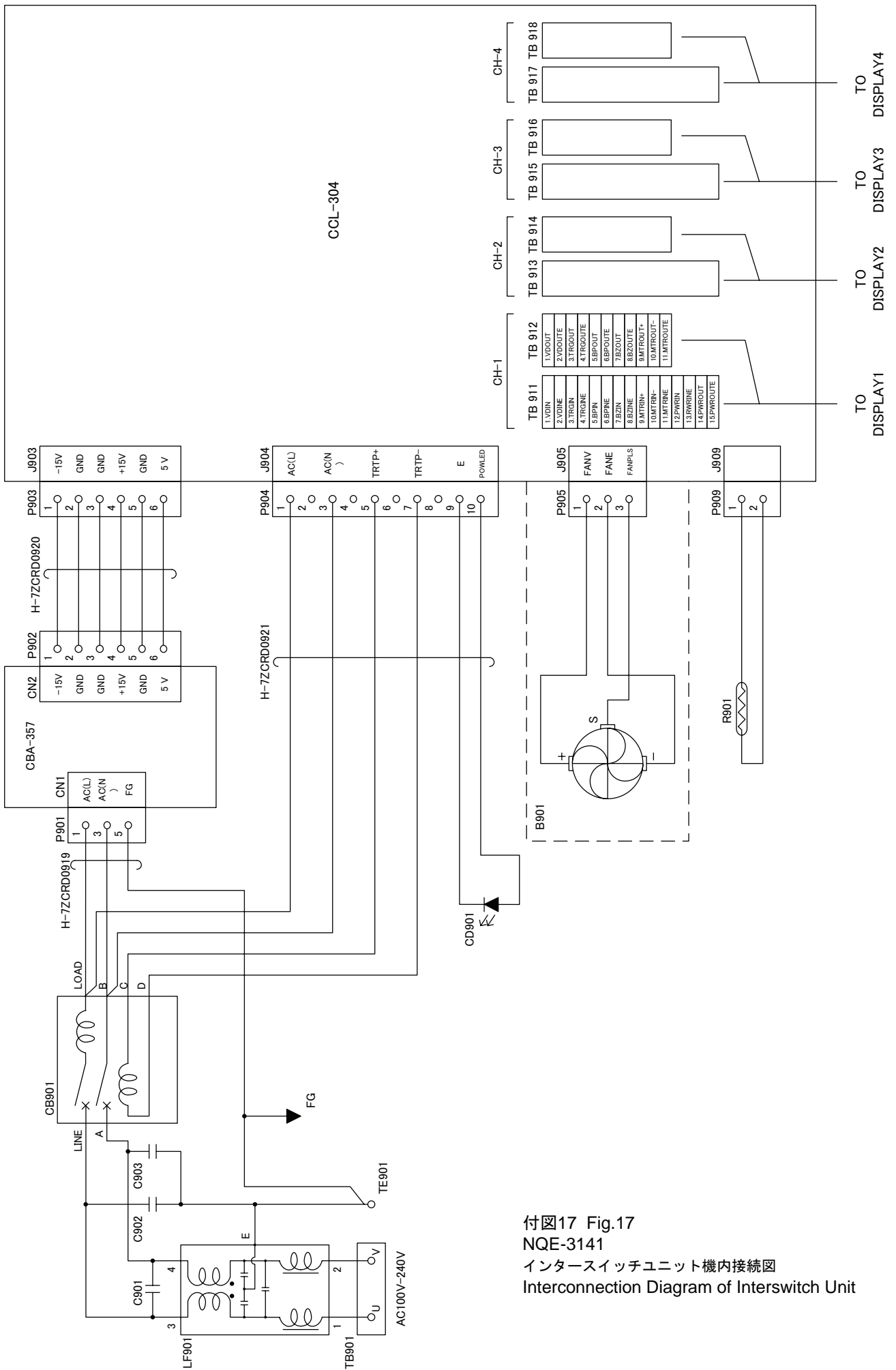

付図17 Fig.17  
 NQE-3141  
 インタースイッチユニット機内接続図  
 Interconnection Diagram of Interswitch Unit

付図18 レーダーメニュー階層  
Fig.18 Over View of RADAR Menu

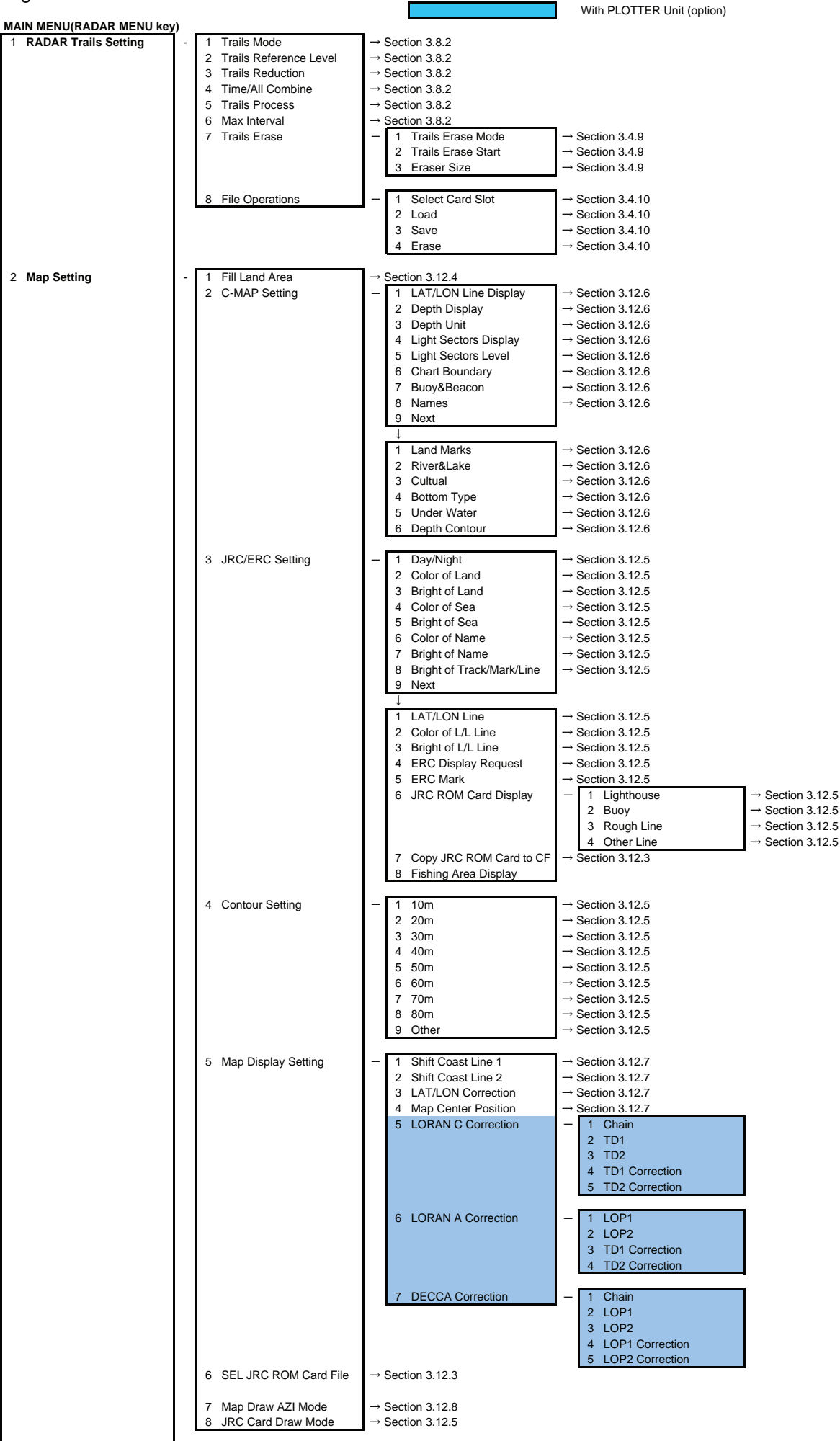

3 TOOL Menu

4 TARGET TRACK Setting (T.TRK)

1 PI Menu

2 Rectangle Cursor

3 EBL Maneuver Setting

4 Trial Maneuver

1 Target Track Function  
2 Target Track Color

3 Target Track Display

4 Track Memory Interval  
5 Clear Track Color  
6 Clear Track Number  
7 File Operations

- 1 Display for All Lines → Section 4.1.5
  - 2 Operation Mode → Section 4.1.5
  - 3 Control → Section 4.1.5
  - 4 Floating → Section 4.1.5
  - 5 Heading Link → Section 4.1.5
  - 6 Next
  - PI Bearing Interval
  - 8 Press EBL Dial to Control Pl#
  - 9 Press VRM Dial to Move End Point#
- ↓
- 1 Range Scale Link → Section 4.1.5
  - 2 Reference Bearing → Section 4.1.5
  - 3 Operation Area → Section 4.1.5
  - 4 Display for Individual Line
  - PI Bearing Interval
  - 8 Press EBL Dial to Control Pl#
  - 9 Press VRM Dial to Move End Point#
- 1 Rectangle Cursor Display
  - 2 Make Rectangle Cursor
  - 3 Ent
  - 4 Unit of Distance
- 1 EBL Maneuver → Section 4.1.6
  - 2 Reach → Section 4.1.6
  - 3 Turn Mode → Section 4.1.6
  - 4 Turn Set → Section 4.1.6
- 1 Trial Function → Section 5.7
  - 2 Course(EBL) → Section 5.7
  - 3 Speed(VRM) → Section 5.7
  - 4 Vector Time → Section 5.7
  - 5 Time to Maneuver → Section 5.7
  - 6 Own Ship's Dynamic Trait
- 1 Reach → Section 5.7
  - 2 Turn Radius → Section 5.7
  - 3 Acceleration → Section 5.7
  - 4 Deceleration → Section 5.7
- Section 5.6.2
- 1 All → Section 5.6.2
  - 2 Target Track No.1 → Section 5.6.2
  - 3 Target Track No.2 → Section 5.6.2
  - 4 Target Track No.3 → Section 5.6.2
  - 5 Target Track No.4 → Section 5.6.2
  - 6 Target Track No.5 → Section 5.6.2
  - 7 Target Track No.6 → Section 5.6.2
  - 8 Target Track No.7 → Section 5.6.2
  - 9 Next
- ↓
- 1 Target Track No.8 → Section 5.6.2
  - 2 Target Track No.9 → Section 5.6.2
  - 3 Target Track No.10 → Section 5.6.2
  - 4 Other → Section 5.6.2
- 1 All → Section 5.6.2
  - 2 Target Track No.1 → Section 5.6.2
  - 3 Target Track No.2 → Section 5.6.2
  - 4 Target Track No.3 → Section 5.6.2
  - 5 Target Track No.4 → Section 5.6.2
  - 6 Target Track No.5 → Section 5.6.2
  - 7 Target Track No.6 → Section 5.6.2
  - 8 Target Track No.7 → Section 5.6.2
  - 9 Next
- ↓
- 1 Target Track No.8 → Section 5.6.2
  - 2 Target Track No.9 → Section 5.6.2
  - 3 Target Track No.10 → Section 5.6.2
  - 4 Other → Section 5.6.2
- 1 Select Card Slot → Section 5.6.2
  - 2 Load Mode → Section 5.6.2
  - 3 Load → Section 5.6.2
  - 4 Save → Section 5.6.2
  - 5 Erase → Section 5.6.2
  - 6 Card T.TRK Display → Section 5.6.2

- 1 Index Line 1 → Section 4.1.5
- 2 Index Line 2 → Section 4.1.5
- 3 Index Line 3 → Section 4.1.5
- 4 Index Line 4 → Section 4.1.5
- 5 Index Line 5 → Section 4.1.5
- 6 Index Line 6 → Section 4.1.5
- 7 Index Line 7 → Section 4.1.5
- 8 Index Line 8 → Section 4.1.5

The setting items are determined by the setting of Operation Mode

All :  
Individual :  
Track :  
Equiangular :

The setting items are determined by the setting of Operation Mode

All :  
Individual :  
Track :  
Equiangular :

Displayed only when "Control" is Individual.

Displayed only when "Control" is Individual.

5 AZ Menu

6 Own Track Menu (O.TRK)

- 1 AZ 1
- 2 AZ 2
- 3 Make AZ
- 4 RADAR Alarm
- 5 Set AZ Key

→ Section 5.2.1

→ Section 5.2.1

- 1 Make AZ 1
- 2 Make AZ 2
- 3 ENT

→ Section 5.2.1

→ Section 5.2.1

- 1 Sector RADAR Alarm
- 3 Make Sector Alarm
- 5 RADAR Alarm Mode
- 6 Sensitivity Level

- 1 Sector Alarm 1
- 2 Sector Alarm 2

→ Section 3.4.24

→ Section 3.4.24

- 1 Sector Alarm 1
- 2 Sector Alarm 2
- 3 ENT

→ Section 3.4.24

→ Section 3.4.24

→ Section 3.4.19

→ Section 3.4.19

- 1 AZ
- 2 Sector RADAR Alarm

- 1 AZ 1
- 2 AZ 2

→ Section 5.2.1

→ Section 5.2.1

- 1 Sector Alarm 1
- 2 Sector Alarm 2

→ Section 3.4.24

→ Section 3.4.24

- 1 DISP Own Track
- 1 DISP Own Track Color
- 2 Clear Own Track
- 2 Clear Own Track Color
- 3 Track Type
- 4 Num/Vector Display
- 5 File Operations
- 6 Water Depth Setting
- 7 Water TEMP. Setting
- 8 Current Setting

→ Section 3.5.1

- 1 All
- 2 White
- 3 Cyan
- 4 Blue
- 5 Green
- 6 Yellow
- 7 Pink
- 8 Red

→ Section 3.5.4

- 1 Select Card Slot
- 2 Load Mode
- 3 Load
- 4 Save
- 5 Erase
- 6 Card Own Track Display

→ Section 3.5.5

→ Section 3.5.5

→ Section 3.5.5

→ Section 3.5.5

→ Section 3.5.5

→ Section 3.5.5

- 1 Depth setting (MIN)
- 2 Depth setting
- 3 Depth setting
- 4 Depth setting
- 5 Depth setting
- 6 Depth setting (MAX)

- 1 Temperature setting (MIN)
- 2 Temperature setting
- 3 Temperature setting
- 4 Temperature setting
- 5 Temperature setting
- 6 Temperature setting (MAX)

- 1 Current Size
- 2 Layer A
- 3 Layer B
- 4 Layer C



7 PLOT Menu

1 Mark Setting

2 Mark Operations

1 Display Mark Type

2 Display Mark Color

3 File Operations

4 Select Mark Size

5 Comment Font Size

1 Own Ship Position

2 Edit User Map

3 Shift

4 Shift Clear

5 Mark/Line Entry

6 Mark/Line List

7 Geodetic

1 All → Section 3.6.2

2 ○ → Section 3.6.2

3 △ → Section 3.6.2

4 ▽ → Section 3.6.2

5 □ → Section 3.6.2

6 ◇ → Section 3.6.2

7 wreck (mark) → Section 3.6.2

8 △△ → Section 3.6.2

9 Next

1 ▽▽ → Section 3.6.2

2 △▽ → Section 3.6.2

3 ▽△ → Section 3.6.2

4 + → Section 3.6.2

5 x → Section 3.6.2

6 Y → Section 3.6.2

7 hand drum (mark) → Section 3.6.2

8 light house (mark) → Section 3.6.2

9 Next

1 trapezoid(mark) → Section 3.6.2

2 filled trapezoid(mark) → Section 3.6.2

3 hat(mark) → Section 3.6.2

4 ●● → Section 3.6.2

5 ● → Section 3.6.2

6 filled triangle(mark) → Section 3.6.2

7 ! → Section 3.6.2

8 anchor(mark) → Section 3.6.2

9 Next

1 slash-anchor(mark) → Section 3.6.2

2 circle-dotted line(mark) → Section 3.6.2

3 non-dangerous wreck(mark) → Section 3.6.2

4 ⊙ → Section 3.6.2

5 mariner's event mark(mark) → Section 3.6.2

6 · → Section 3.6.2

7 wavy line (mark) → Section 3.6.2

8 solid line (mark) → Section 3.6.2

9 Next

1 dashed-dotted line (mark) → Section 3.6.2

1 All → Section 3.6.2

2 White → Section 3.6.2

3 Cyan → Section 3.6.2

4 Blue → Section 3.6.2

5 Green → Section 3.6.2

6 Yellow → Section 3.6.2

7 Pink → Section 3.6.2

8 Red → Section 3.6.2

1 Select Card Slot → Section 3.6.6

2 Load Mode → Section 3.6.6

3 Load → Section 3.6.6

4 Unload → Section 3.6.6

5 Save → Section 3.6.6

6 Erase → Section 3.6.6

7 Card Mark Display → Section 3.6.6

→ Section 3.6.2

→ Section 3.6.2

→ Section 3.6.3

1 Make with Cursor

2 Make with L/L

3 Move → Section 3.6.3

4 Delete → Section 3.6.3

5 Insert/Move Vertex → Section 3.6.3

6 Delete Vertex → Section 3.6.3

7 Delete by Type by Color → Section 3.6.3

1 Type → Section 3.6.1

2 Color → Section 3.6.1

1 Type → Section 3.6.1

2 Color → Section 3.6.1

3 L/L → Section 3.6.1

4 Comment → Section 3.6.1

5 Enter → Section 3.6.1

9 New Line Input → Section 3.6.1

New Mark Input ↔

→ Section 3.6.5

→ Section 3.6.5

→ Section 3.6.4

→ Section 3.6.4

→ Section 3.6.7

- 7 PLOT Menu
- 9 Next

- 3 WPT/Route Setting (Route Type : Plotter)
- 4 WPT/Route Operation
- 5 Clear Memory
- 6 Plot Setting
- 7 NMEA Waypoint Display

- 1 Waypoint Alarm
- 2 Route Alarm
- 3 Set Route Sequence
- 4 Select Route
- 5 Waypoint Entry
- 6 Waypoint Input
- 7 Save Temporary Route
- 8 Cross Track Limit Line
- 9 Next

- 1 Select WPT Mark Size
- 2 Waypoint Vector
- 3 Status of Origin/DEST
- 4 WPT Number Display
- 5 RTE Number Display

- 1 Route Sequence
- 2 Waypoint Switch Mode
- 3 Waypoint Skip
- 4 Waypoint Back Skip
- 5 Set/Cancel Waypoint

- 1 Clear Mark/Line Data
- 2 Clear WPT/Route Data

→ Section 3.6.2

- 1 Scale/Course Up Setup
- 2 Current Position Display
- 3 Cursor Vector DISP
- 4 Cursor HL Length
- 5 Scalebar Display
- 6 AUTO Backup

- 1 Scale
- 2 Preset Scale
- 3 Course Up Data

- 1 Tolerance
- 2 Averaging
- 3 Round Speed

→ Section 3.7.1

Press RADAR MENU again

- 1 File Manager
- 2 RADAR Menu

→ Section 3.11.1

- 1 Process Setting
- 3 TXRX Setting

- 1 Video Latitude
- 2 Video Noise Rejection
- 3 AUTO Dynamic Range
- 4 Process Switch
- 5 2nd Process Mode
- 6 Process Switch Range
- 7 Fast Target Detection
- 8 User Function Setting

→ Section 3.8.1  
→ Section 3.8.1  
→ Section 3.8.1  
→ Section 3.8.1  
→ Section 3.8.1  
→ Section 3.8.1  
→ Section 3.8.1

- 1 Function1 Setting
- 2 Function2 Setting
- 3 Function3 Setting
- 4 Function4 Setting
- 9 SART

→ Section 6.5

- 1 Mode
- 2 IR
- 3 Process
- 4 Target Enhance
- 5 AUTO Sea/Rain
- 6 Save Present State
- 9 Next

→ Section 3.9.3  
→ Section 3.9.3  
→ Section 3.9.3  
→ Section 3.9.3  
→ Section 3.9.3  
→ Section 3.9.3

- 1 Pulse Length 0.75nm
- 2 Pulse Length 1.5nm
- 3 Pulse Length 3/4nm
- 4 Pulse Length 6/8nm
- 5 Pulse Length 12nm
- 6 Pulse Length 16nm
- 9 Next

→ Section 3.9.3  
→ Section 3.9.3  
→ Section 3.9.3  
→ Section 3.9.3  
→ Section 3.9.3  
→ Section 3.9.3

- 1 Video Latitude
- 2 Video Noise Rejection
- 3 AUTO Dynamic Range
- 4 Process Switch
- 5 2nd Process Mode
- 6 Process Switch Range
- 7 Fast Target Detection
- 9 Next

→ Section 3.9.3  
→ Section 3.9.3  
→ Section 3.9.3  
→ Section 3.9.3  
→ Section 3.9.3  
→ Section 3.9.3  
→ Section 3.9.3

- 1 Trails Interval
- 2 Trails Mode
- 3 Trails Reference Level
- 4 Trails Reduction
- 5 Time/All Combine
- 6 Trails Process
- 7 Max Interval
- 9 Next

→ Section 3.9.3  
→ Section 3.9.3  
→ Section 3.9.3  
→ Section 3.9.3  
→ Section 3.9.3  
→ Section 3.9.3  
→ Section 3.9.3

- 1 Gain Offset
- 2 PRF
- 3 Small Buoy Detection
- 4 Fishnet Detection
- 5 Antenna Height
- 8 Set Mode Default
- 9 Initialize

→ Section 3.9.3  
→ Section 3.9.3  
→ Section 3.9.3  
→ Section 3.9.3  
→ Section 3.9.3  
→ Section 3.9.3  
→ Section 3.9.3

- 1 PRF Fine Tuning
- 2 Stagger Trigger
- 4 PRF
- 5 Ice Class Standby Mode

→ Section 3.8.3  
→ Section 3.8.3  
→ Section 3.8.3  
→ Section 3.8.3

3 Multi Window Setting	1 DIR/DIST EXP Display	→ Section 3.8.8																																																
	2 Numeric NAV INFO	→ Section 3.8.8																																																
	3 Depth Graph Setting		<table border="1"> <tr><td>1 Depth Graph Display</td><td>→ Section 3.8.8</td></tr> <tr><td>2 Depth Range</td><td>→ Section 3.8.8</td></tr> <tr><td>3 Time Range</td><td>→ Section 3.8.8</td></tr> <tr><td>4 Depth Unit</td><td>→ Section 3.8.8</td></tr> </table>	1 Depth Graph Display	→ Section 3.8.8	2 Depth Range	→ Section 3.8.8	3 Time Range	→ Section 3.8.8	4 Depth Unit	→ Section 3.8.8																																							
	1 Depth Graph Display	→ Section 3.8.8																																																
	2 Depth Range	→ Section 3.8.8																																																
	3 Time Range	→ Section 3.8.8																																																
4 Depth Unit	→ Section 3.8.8																																																	
4 Wind Graph		<table border="1"> <tr><td>1 Wind Graph Display</td><td>→ Section 3.8.8</td></tr> <tr><td>2 Wind Speed Unit</td><td>→ Section 3.8.8</td></tr> </table>	1 Wind Graph Display	→ Section 3.8.8	2 Wind Speed Unit	→ Section 3.8.8																																												
1 Wind Graph Display	→ Section 3.8.8																																																	
2 Wind Speed Unit	→ Section 3.8.8																																																	
5 TEMP Graph Setting		<table border="1"> <tr><td>1 TEMP Graph Display</td><td>→ Section 3.8.8</td></tr> <tr><td>2 TEMP Graph Color</td><td>→ Section 3.8.8</td></tr> <tr><td>3 TEMP Range</td><td></td></tr> <tr><td>4 Time Range</td><td>→ Section 3.8.8</td></tr> </table> <table border="1"> <tr><td>1 Temperature setting (MIN)</td><td>→ Section 3.8.8</td></tr> <tr><td>2 Temperature setting</td><td>→ Section 3.8.8</td></tr> <tr><td>3 Temperature setting</td><td>→ Section 3.8.8</td></tr> <tr><td>4 Temperature setting</td><td>→ Section 3.8.8</td></tr> <tr><td>5 Temperature setting</td><td>→ Section 3.8.8</td></tr> <tr><td>6 Temperature setting (MAX)</td><td>→ Section 3.8.8</td></tr> </table>	1 TEMP Graph Display	→ Section 3.8.8	2 TEMP Graph Color	→ Section 3.8.8	3 TEMP Range		4 Time Range	→ Section 3.8.8	1 Temperature setting (MIN)	→ Section 3.8.8	2 Temperature setting	→ Section 3.8.8	3 Temperature setting	→ Section 3.8.8	4 Temperature setting	→ Section 3.8.8	5 Temperature setting	→ Section 3.8.8	6 Temperature setting (MAX)	→ Section 3.8.8																												
1 TEMP Graph Display	→ Section 3.8.8																																																	
2 TEMP Graph Color	→ Section 3.8.8																																																	
3 TEMP Range																																																		
4 Time Range	→ Section 3.8.8																																																	
1 Temperature setting (MIN)	→ Section 3.8.8																																																	
2 Temperature setting	→ Section 3.8.8																																																	
3 Temperature setting	→ Section 3.8.8																																																	
4 Temperature setting	→ Section 3.8.8																																																	
5 Temperature setting	→ Section 3.8.8																																																	
6 Temperature setting (MAX)	→ Section 3.8.8																																																	
6 Course Bar Setting		<table border="1"> <tr><td>1 Course Bar Display</td><td>→ Section 3.8.8</td></tr> <tr><td>2 Autopilot Course</td><td>→ Section 3.8.8</td></tr> <tr><td>3 ROT Scale</td><td>→ Section 3.8.8</td></tr> </table>	1 Course Bar Display	→ Section 3.8.8	2 Autopilot Course	→ Section 3.8.8	3 ROT Scale	→ Section 3.8.8																																										
1 Course Bar Display	→ Section 3.8.8																																																	
2 Autopilot Course	→ Section 3.8.8																																																	
3 ROT Scale	→ Section 3.8.8																																																	
4 NAV Equipment Setting	1 GYRO Setting	→ Section 3.4.16 → Section 7.1.7																																																
	2 MAG Compass Setting		<table border="1"> <tr><td>1 Heading Correction</td><td>→ Section 3.4.18</td></tr> <tr><td>2 Correct Value</td><td>→ Section 3.4.18</td></tr> </table>	1 Heading Correction	→ Section 3.4.18	2 Correct Value	→ Section 3.4.18																																											
	1 Heading Correction	→ Section 3.4.18																																																
	2 Correct Value	→ Section 3.4.18																																																
	3 Set/Drift Setting		<table border="1"> <tr><td>1 Correction</td><td>→ Section 3.4.19</td></tr> <tr><td>2 Set</td><td>→ Section 3.4.19</td></tr> <tr><td>3 Drift</td><td>→ Section 3.4.19</td></tr> </table>	1 Correction	→ Section 3.4.19	2 Set	→ Section 3.4.19	3 Drift	→ Section 3.4.19																																									
	1 Correction	→ Section 3.4.19																																																
2 Set	→ Section 3.4.19																																																	
3 Drift	→ Section 3.4.19																																																	
4 GPS Setting		<table border="1"> <tr><td>1 GPS Process Setting</td><td></td></tr> <tr><td>2 DGPS Setting</td><td></td></tr> <tr><td>3 SBAS Setting</td><td></td></tr> <tr><td>4 GPS Status</td><td>→ Section 3.4.23</td></tr> </table> <table border="1"> <tr><td>1 Position</td><td>→ Section 3.4.20</td></tr> <tr><td>2 Exclusion</td><td>→ Section 3.4.20</td></tr> <tr><td>3 Geodetic</td><td>→ Section 3.4.20</td></tr> <tr><td>4 Antenna Height</td><td>→ Section 3.4.20</td></tr> <tr><td>5 Fix Mode</td><td>→ Section 3.4.20</td></tr> <tr><td>6 DOP Level</td><td>→ Section 3.4.20</td></tr> <tr><td>7 Position Average</td><td>→ Section 3.4.20</td></tr> <tr><td>8 Master Reset</td><td>→ Section 3.4.20</td></tr> <tr><td>9 Send Data</td><td>→ Section 3.4.20</td></tr> </table> <table border="1"> <tr><td>1 Mode</td><td>→ Section 3.4.21</td></tr> <tr><td>2 Frequency</td><td>→ Section 3.4.21</td></tr> <tr><td>3 Baud Rate(BPS)</td><td>→ Section 3.4.21</td></tr> <tr><td>4 DGPS Mode</td><td>→ Section 3.4.21</td></tr> <tr><td>5 Send Data</td><td>→ Section 3.4.21</td></tr> </table> <table border="1"> <tr><td>1 Mode</td><td>→ Section 3.4.22</td></tr> <tr><td>2 Ranging</td><td>→ Section 3.4.22</td></tr> <tr><td>3 NG SBAS</td><td>→ Section 3.4.22</td></tr> <tr><td>4 SBAS Select Mode</td><td>→ Section 3.4.22</td></tr> <tr><td>5 SBAS No.</td><td>→ Section 3.4.22</td></tr> <tr><td>6 Send Data</td><td>→ Section 3.4.22</td></tr> </table>	1 GPS Process Setting		2 DGPS Setting		3 SBAS Setting		4 GPS Status	→ Section 3.4.23	1 Position	→ Section 3.4.20	2 Exclusion	→ Section 3.4.20	3 Geodetic	→ Section 3.4.20	4 Antenna Height	→ Section 3.4.20	5 Fix Mode	→ Section 3.4.20	6 DOP Level	→ Section 3.4.20	7 Position Average	→ Section 3.4.20	8 Master Reset	→ Section 3.4.20	9 Send Data	→ Section 3.4.20	1 Mode	→ Section 3.4.21	2 Frequency	→ Section 3.4.21	3 Baud Rate(BPS)	→ Section 3.4.21	4 DGPS Mode	→ Section 3.4.21	5 Send Data	→ Section 3.4.21	1 Mode	→ Section 3.4.22	2 Ranging	→ Section 3.4.22	3 NG SBAS	→ Section 3.4.22	4 SBAS Select Mode	→ Section 3.4.22	5 SBAS No.	→ Section 3.4.22	6 Send Data	→ Section 3.4.22
1 GPS Process Setting																																																		
2 DGPS Setting																																																		
3 SBAS Setting																																																		
4 GPS Status	→ Section 3.4.23																																																	
1 Position	→ Section 3.4.20																																																	
2 Exclusion	→ Section 3.4.20																																																	
3 Geodetic	→ Section 3.4.20																																																	
4 Antenna Height	→ Section 3.4.20																																																	
5 Fix Mode	→ Section 3.4.20																																																	
6 DOP Level	→ Section 3.4.20																																																	
7 Position Average	→ Section 3.4.20																																																	
8 Master Reset	→ Section 3.4.20																																																	
9 Send Data	→ Section 3.4.20																																																	
1 Mode	→ Section 3.4.21																																																	
2 Frequency	→ Section 3.4.21																																																	
3 Baud Rate(BPS)	→ Section 3.4.21																																																	
4 DGPS Mode	→ Section 3.4.21																																																	
5 Send Data	→ Section 3.4.21																																																	
1 Mode	→ Section 3.4.22																																																	
2 Ranging	→ Section 3.4.22																																																	
3 NG SBAS	→ Section 3.4.22																																																	
4 SBAS Select Mode	→ Section 3.4.22																																																	
5 SBAS No.	→ Section 3.4.22																																																	
6 Send Data	→ Section 3.4.22																																																	
5 Weather INFO Setting		<table border="1"> <tr><td>1 Display Weather INFO</td><td></td></tr> <tr><td>2 SEL Observation Place</td><td></td></tr> <tr><td>3 RX Message Display</td><td></td></tr> <tr><td>4 RX Buzzer</td><td></td></tr> </table>	1 Display Weather INFO		2 SEL Observation Place		3 RX Message Display		4 RX Buzzer																																									
1 Display Weather INFO																																																		
2 SEL Observation Place																																																		
3 RX Message Display																																																		
4 RX Buzzer																																																		

5 Sub Menu	1 Display Color Setting		
	2 Brilliance Setting		
	3 User Setting		
	4 User Key Setting		
	5 Buzzer Volume		
	6 Date/Time Setting		
	7 Screen Capture Setting		
	9 EBL/Cursor Setting		
	6 TT Menu	1 Association Setting	
	3 Trial Maneuver		
	4 Target Number Display		
	9 TT Test Menu		

1 Day/Night	→ Section 3.8.5
2 Outer PPI	→ Section 3.8.5
3 Inner PPI	→ Section 3.8.5
4 Character	→ Section 3.8.5
5 RADAR Video	→ Section 3.8.5
6 RADAR Trails(Time)	→ Section 3.8.5
7 RADAR Trails(All)	→ Section 3.8.5
8 Target Symbol	→ Section 3.8.5
9 Next	→ Section 3.8.5
↓	
1 Cursor	→ Section 3.8.5
2 Range Rings	→ Section 3.8.5
3 EBL/VRM/PI	→ Section 3.8.5
4 Own Symbol/HL/Vector	→ Section 3.8.5
1 RADAR Video	→ Section 3.8.5
2 RADAR Trails	→ Section 3.8.5
3 Target Symbol	→ Section 3.8.5
4 Range Rings	→ Section 3.8.5
5 EBL/VRM/PI	→ Section 3.8.5
6 Character	→ Section 3.8.5
7 Own Symbol/HL/Vector	→ Section 3.8.5
8 Keyboard	→ Section 3.8.5
1 Load User Setting	→ Section 3.10.2
2 Save User Setting	→ Section 3.10.1
3 Delete User Setting	→ Section 3.10.3
1 User Key 1	→ Section 3.8.7
2 User Key 2	→ Section 3.8.7
1 Key ACK	→ Section 3.8.6
2 OPE Miss	→ Section 3.8.6
3 CPA/TCPA Alarm	→ Section 3.8.6
4 New Target Alarm	→ Section 3.8.6
5 Lost Alarm	→ Section 3.8.6
6 Navigation Alarm	→ Section 3.8.6
7 System Alarm	→ Section 3.8.6
8 Inter Switch	→ Section 3.8.6
1 UTC/LMT	→ Section 7.2.7
2 LMT Date	→ Section 7.2.7
3 LMT Time	→ Section 7.2.7
4 Time Zone	→ Section 7.2.7
5 Display Style	→ Section 7.2.7
6 Synchronize with GPS	→ Section 7.2.7
1 Select Item	
2 Select Card Slot	
3 File Erase	
4 AUTO Capture Interval	
5 AUTO File Erase	
1 Graphic	
2 RADAR Video	
3 RADAR Trails	
4 Chart	
1 EBL1 Bearing Fix	→ Section 4.1.3
2 EBL2 Bearing Fix	→ Section 4.1.3
3 Cursor Setting	
1 EBL/VRM Control CURS	→ Section 3.8.4
2 Cursor Length	→ Section 3.8.4
4 Cursor Pattern	→ Section 3.8.4
1 Association	→ Section 5.4
2 Priority	→ Section 5.4
3 Bearing	→ Section 5.4
4 Range	→ Section 5.4
5 Course	→ Section 5.4
6 Speed	→ Section 5.4
7 Applicable AIS Target	→ Section 5.4
1 Trial Function	→ Section 5.7
2 Course(EBL)	→ Section 5.7
3 Speed(VRM)	→ Section 5.7
4 Vector Time	→ Section 5.7
5 Time to Maneuver	→ Section 5.7
6 Own Ship's Dynamic Trait	
1 Reach	→ Section 5.7
2 Turn Radius	→ Section 5.7
3 Acceleration	→ Section 5.7
4 Deceleration	→ Section 5.7
→ Section 5.2.4	
1 Test Video	→ Section 5.2.7
2 TT Simulator	→ Section 5.2.7
3 Status	→ Section 5.2.7
4 Gate Display	→ Section 5.2.7

7 AIS Menu	1 Association Setting	1 Association → Section 5.4	
		2 Priority → Section 5.4	
		3 Bearing → Section 5.4	
		4 Range → Section 5.4	
		5 Course → Section 5.4	
		6 Speed → Section 5.4	
		7 Applicable AIS Target → Section 5.4	
	3 Trial Maneuver	1 Trial Function → Section 5.7	
		2 Course(EBL) → Section 5.7	
		3 Speed(VRM) → Section 5.7	
	4 Vector Time → Section 5.7		
	5 Time to Maneuver → Section 5.7		
	6 Own Ship's Dynamic Trait	1 Reach → Section 5.7	
		2 Turn Radius → Section 5.7	
		3 Acceleration → Section 5.7	
		4 Deceleration → Section 5.7	
4 AIS Filter Setting	1 Filter Type → Section 5.3.7		
	2 Make AIS Filter → Section 5.3.7		
	3 Filter Display → Section 5.3.7		
	4 ENT → Section 5.3.7		
	6 Filter Mode → Section 5.3.7		
5 Target Number Display	→ Section 5.3.6		
6 AIS Alarm Setting	1 Lost Alarm → Section 5.3.9		
	2 CPA/TCPA Alarm → Section 5.3.9		
7 Message	1 Addressed Message → Section 5.3.5		
	2 Broadcast Message → Section 5.3.5		
8 Display Lost TGT Data	→ Section 5.3.5		
9 Own Ship's AIS Data	→ Section 5.3.5		
8 Multi Dial Setting	1 Vector Time → Section 3.3.6		
	2 Trails Length → Section 3.3.6		
	3 TT Display No. → Section 3.3.6		
	4 C-UP Angle → Section 3.3.6		
	5 Own Track Color → Section 3.3.6		
	6 Mark/Line Color → Section 3.3.6		
	7 Manual Tune → Section 3.3.6		
9 Test Menu	1 Self Test	1 Memory Test	1 SDRAM → Section 8.3.1
			2 SRAM → Section 8.3.1
			3 FLASH ROM → Section 8.3.1
			4 GRAPHIC → Section 8.3.1
		2 TXRX Test → Section 8.3.1	
		3 Line Test → Section 8.3.1	
		4 Supply Voltage → Section 8.3.1	
	2 Monitor Test	1 Pattern 1 → Section 8.3.1	
		2 Pattern 2 → Section 8.3.1	
		3 Pattern 3 → Section 8.3.1	
	4 Pattern 4 → Section 8.3.1		
	5 Pattern 5 → Section 8.3.1		
	6 Pattern 6 → Section 8.3.1		
	7 Pattern 7 → Section 8.3.1		
	8 Pattern 8 → Section 8.3.1		
3 Keyboard Test	1 Key Test → Section 8.3.1		
	2 Buzzer Test → Section 8.3.1		
	3 Light Test → Section 8.3.1		
4 MON Display	→ Section 8.3.1		
5 System Alarm Log	→ Section 8.3.1		
6 System Information	→ Section 8.3.1		
0 EXIT			

Serviceman Menu

→ Section 7.1.1

- 1 Adjust Menu
- 2 Installation Menu

- 1 Tune Adjustment
- 2 Bearing Adjustment
- 3 Range Adjustment
- 4 TXRX Adjustment

→ Section 7.1.3  
 → Section 7.1.4  
 → Section 7.1.5

- 1 Antenna Height
- 2 Tune Peak Adjustment
- 3 Tune Indicator Adjust
- 4 MON Adjustment
- 5 MON Indicator Adjustment
- 6 Output Pulse

→ Section 7.1.8  
 → Section 7.1.3  
 → Section 7.1.3  
 → Section 7.3.4  
 → Section 7.3.3  
 → Section 7.2.4

- 1 Installation Information
- 2 Master/Slave
- 3 Sector Blank

→ Section 7.2.8  
 → Section 7.2.8  
 → Section 7.2.8

- 1 Sector1
- 2 Sector2
- 3 Sector3
- 4 Make Sector1
- 5 Make Sector2
- 6 Make Sector3

→ Section 7.2.5  
 → Section 7.2.2  
 → Section 7.2.2  
 → Section 7.2.2  
 → Section 7.2.2  
 → Section 7.2.2  
 → Section 7.2.2

- 4 CCRP Setting
- 5 COM Port Setting

→ Section 7.1.9

- 1 Baud Rate

- 1 COMPASS
- 2 NAV1
- 3 NAV2
- 4 GPS
- 5 NMEA

→ Section 7.2.1  
 → Section 7.2.1  
 → Section 7.2.1  
 → Section 7.2.1  
 → Section 7.2.1

- 2 RX Port

- 1 GPS
- 2 DLOG
- 3 Alarm
- 4 Depth
- 5 Temperature
- 6 Wind
- 7 Current
- 8 ROT
- 9 Next

→ Section 7.2.1  
 → Section 7.2.1  
 → Section 7.2.1  
 → Section 7.2.1  
 → Section 7.2.1  
 → Section 7.2.1  
 → Section 7.2.1  
 → Section 7.2.1

- 1 RSA

→ Section 7.2.1

- 3 RX Sentence

- 1 GPS(LL/COG/SOG)
- 2 GPS(WPT/TIME)
- 3 Depth
- 4 Wind
- 5 Current

→ Section 7.2.1  
 → Section 7.2.1  
 → Section 7.2.1  
 → Section 7.2.1

- 1 Data Set Number
- 2 Layer A
- 3 Layer B
- 4 Layer C

→ Section 7.2.1  
 → Section 7.2.1  
 → Section 7.2.1  
 → Section 7.2.1

- 4 TX Port

- 1 TTM(TT)
- 2 TLL(TT)
- 3 TTD(TT)
- 4 TLB(TT)
- 5 OSD
- 6 RSD
- 7 ALR
- 8 ACK
- 9 Next

→ Section 7.2.1  
 → Section 7.2.1  
 → Section 7.2.1  
 → Section 7.2.1  
 → Section 7.2.1  
 → Section 7.2.1  
 → Section 7.2.1  
 → Section 7.2.1

- 1 TTM(AIS)
- 2 TLL(AIS)
- 3 TTD(AIS)
- 4 TLB
- 5 Remote Maintenance
- 6 JRC-ARPA
- 7 NMEA0183 Output Format
- 8 NMEA0183 Talker
- 9 Next

→ Section 7.2.1  
 → Section 7.2.1  
 → Section 7.2.1  
 → Section 7.2.1  
 → Section 7.2.1  
 → Section 7.2.1  
 → Section 7.2.1  
 → Section 7.2.1

- 1 NMEA0183 TX Interval
- 2 APB
- 3 BOD
- 4 GGA
- 5 GLL
- 6 RMC
- 7 RMB
- 8 VTG
- 9 Next

→ Section 7.2.1  
 → Section 7.2.1  
 → Section 7.2.1  
 → Section 7.2.1  
 → Section 7.2.1  
 → Section 7.2.1  
 → Section 7.2.1  
 → Section 7.2.1

- 1 XTE
- 2 BWC
- 3 HDT
- 4 THS

→ Section 7.2.1  
 → Section 7.2.1  
 → Section 7.2.1  
 → Section 7.2.1

- 5 Select NAV Equipment
- 7 Line Monitor

→ Section 7.2.1

- 1 COMPASS
- 2 NAV1
- 3 NAV2/ARPA
- 4 GPS
- 5 NMEA
- 6 TXRX/ISW
- 7 KEYBOARD1
- 8 KEYBOARD2

→ Section 7.2.1  
 → Section 7.2.1  
 → Section 7.2.1  
 → Section 7.2.1  
 → Section 7.2.1  
 → Section 7.2.1  
 → Section 7.2.1

Serviceman Menu

→ Section 7.1.1

2 Installation Menu

6 Alarm System

7 Inter Switch

8 Language

9 Next

1 Input BP Count

2 TNI Blank

3 Device Installation

4 Network

1 Safety Switch

2 Area Initial

3 Internal To Card 1/2

4 Card 1/2 To Internal

5 TXRX Time

6 String Data Update

9 RADAR/TT Initial Setup

1 Signal Processing

2 TT

3 MBS

2 Relay Output

3 ALR Output

5 External ACK Setting

1 ISW Install

2 Mask Setting

3 S-ISW TXRX Power Supply

1 Relay Output Mode

2 TT CPA/TCPA

3 AIS CPA/TCPA

4 New Target

5 Lost

6 RADAR Alarm

1 System Alarm

2 TT/AIS Alarm

1 Critical Alarm

2 Normal Alarm

1 Audio

2 Indication

3 Acknowledge State

1 Audio

2 Indication

3 Acknowledge State

→ Section 7.2.9

→ Section 7.2.9

→ Section 7.2.9

→ Section 7.2.9

→ Section 7.2.9

→ Section 7.2.9

→ Section 7.2.9

→ Section 7.2.9

→ Section 7.2.9

→ Section 7.2.9

1 No.1 Connection

No.1 Master

2 No.2 Connection

No.2 Master

3 No.3 Connection

No.3 Master

4 No.4 Connection

No.4 Master

5 No.5 Connection

No.5 Master

6 No.6 Connection

No.6 Master

7 No.7 Connection

No.7 Master

8 No.8 Connection

No.8 Master

1 TNI Blank

2 Make Sector

1 Gyro

2 Compass

3 GPS Compass

4 LOG

5 2AXW

6 2AXG

7 GPS

1 Network Function

2 IP Address

Only for ISW Extended Mode

→ Section 7.2.6

1 Gyro

2 Compass

3 GPS Compass

4 LOG

5 2AXW

6 2AXG

7 GPS

→ Section 7.2.5

→ Section 7.2.3

→ Section 7.2.3

→ Section 7.1.6

→ Section 7.1.6

→ Section 7.1.6

→ Section 7.1.6

→ Section 7.1.6

→ Section 7.1.6

→ Section 7.1.6

1 Partial Master Reset

2 All Master Reset

1 Serviceman Menu

2 Except Serviceman Menu

3 User Setting

4 TT Setting

5 AIS Setting

6 Day/Night

7 JRC Card Copy Record

→ Section 7.4.1

→ Section 7.4.2

→ Section 7.4.2

→ Section 7.4.2

→ Section 7.4.2

→ Section 7.4.2

→ Section 7.4.2

→ Section 7.4.2

→ Section 7.4.3

1 Clear TX Time

2 Clear Motor Time

3 TXRX to Display Unit

4 Display Unit to TXRX

→ Section 7.4.3

→ Section 7.4.4

→ Section 7.4.4

→ Section 7.4.4

→ Section 7.4.4

→ Section 7.4.5

1 Echo Noise Level

2 Setting Mode

→ Section 7.3.1

→ Section 7.3.1

1 Vector Constant

2 Video TD Level

3 Video High Level

4 Video Low Level

5 Gate Size

6 Limit Ring

→ Section 7.3.2

→ Section 7.3.2

→ Section 7.3.2

→ Section 7.3.2

→ Section 7.3.2

→ Section 7.3.2

1 MBS Level

2 MBS Area

→ Section 7.3.3

→ Section 7.3.3







CE 0191 ⚠

アスベストは使用していません  
Not use the asbestos

CODE No.7ZPRD0671

For further information, contact:

**JRC** *Japan Radio Co., Ltd.*  
Since 1915

URL <http://www.jrc.co.jp>

Marine Service Department

Telephone : +81-3-3492-1305

Facsimile : +81-3-3779-1420

e-mail : [tmisc@jrc.co.jp](mailto:tmisc@jrc.co.jp)

AMSTERDAM Branch

Telephone : +31-20-658-0750

Facsimile : +31-20-658-0755

e-mail : [service@jrcams.nl](mailto:service@jrcams.nl)

SEATTLE Branch

Telephone : +1-206-654-5644

Facsimile : +1-206-654-7030

e-mail : [service@jrcamerica.com](mailto:service@jrcamerica.com)

01ETM

ISO 9001, ISO 14001 Certified

©JUL. 2008 Edition 3 JRC

Printed in Japan