

JMA-2343/2344

**船舶用レーダ装置
MARINE RADAR
EQUIPMENT**

**取扱説明書
INSTRUCTION
MANUAL**

JRC 日本無線株式會社
JRC *Japan Radio Co., Ltd.*

はじめに

このたびは、JRC船舶レーダJMA-2343/JMA-2344をお買い上げいただきまして、まことにありがとうございます。

本装置は、レーダ信号の送受信部、ブラウン管表示部および空中線等の主要部からなる、船舶の安全航行を図るための船舶用レーダ装置です。

- お使いになる前に、この取扱説明書をよくお読みのうえ、正しくお使いください。
- 取扱説明書は必要なときに参照できるよう大切に保管してください。
万一、ご使用中にわからないことや不具合が生じたときにお役立てください。

PREFACE

Thank you very much for purchasing the JRC marine radar equipment, JMA-2343 and JMA-2344.

This equipment is a marine radar equipment designed to obtain safe operation of marine ships. The equipment consists of a radar signal transceiver unit, a CRT display unit and a scanner unit as its main units.

- Before operating the equipment, be sure to read this instruction manual carefully for correct operation.
- Maintain this instruction manual so that operators can refer to it at anytime.
Refer to this manual when any inconvenience or defect occur.

●ご使用のまえに●

絵表示について

この取扱説明書および製品への表示では、製品を安全に正しくお使いいただき、あなたや他の人々への危害や財産への損害を未然に防止するために、いろいろな絵表示をしています。その表示と意味は次のようになっています。

内容をよく理解してから本文をお読みください。



警告

この表示を無視して、誤った取扱いをすると、人が死亡または重傷を負う可能性が想定される内容を示しています。



注意

この表示を無視して、誤った取扱いをすると、人が傷害を負う可能性が想定される内容および物的損害のみの発生が想定される内容を示しています。

絵表示の例



感電注意

△記号は注意（危険・警告を含む）を促す内容があることを告げるものです。

図の中に具体的な注意内容（左図の場合は感電注意）が描かれています。



分解禁止



禁止

⊙記号は禁止の行為であることを告げるものです。

図の中や近傍に具体的な禁止内容（左図の場合は分解禁止）が描かれています。



プラグ
を抜け



指示

●記号は行為を強制したり指示する内容を告げるものです。

図の中に具体的な指示内容（左図の場合は電源プラグをコンセントから抜け）が描かれています。

警告ラベルについて

本製品の上カバーには警告ラベルが貼ってあります。

警告ラベルを取り外したり、破損、改変を絶対にしないでください。

● Before Operation ●

Pictorial Indication

Various pictorial indications are included in this manual and are shown on these equipment so that you can operate them safely and correctly and prevent any danger to you and / or to other persons and any damage to your property during operation. Such indications and their meanings are as follows.

Please understand them before you read this manual:



WARNING

This indication is shown where any person is supposed to be in danger of being killed or seriously injured if this indication is neglected and these equipment are not operated correctly.



CAUTION

This indication is shown where any person is supposed to be injured or any property damage is supposed to occur if this indication is neglected and these equipment are not operated correctly.

Examples of pictorial indication



Electric Shock

The Δ mark represents CAUTION (including DANGER and WARNING). Detailed contents of CAUTION ("Electric Shock" in the example on the left.) is shown in the mark.



Disassembling Prohibited



Prohibition

The \circ mark represents prohibition.

Detailed contents of the prohibited action ("Disassembling Prohibited" in the example on the left) is shown in the mark.



Disconnect the power plug



instruction

The \bullet mark represents instruction.

Detailed contents of the instruction ("Disconnect the power plug" in the example on the left) is shown in the mark.

Warning label

There is a warning label on the top cover of the equipment.

Do not try to remove, break or modify the label.

●ご使用上の注意●

警告



空中線、送受信機及び指示機の内部には触れないでください。

高電圧部により感電の原因となります。機器内部の保守、点検、調整等は当社の営業部またはお近くの支社・支店・営業所または代理店にサービスを依頼してください。

当社の営業部・支社・支店・営業所

巻末の「事業所一覧」をご覧ください。



空中線輻射部は回転しますので、近づかないでください。

急に空中線が回転し人体を殴打して、負傷する原因となります。

空中線輻射部は人が近づけないよう操舵室の屋根、フライングブリッジ、架台、レーダースタブ等の高い場所に設置することをおすすめします。また、人の近づく恐れのある場合は空中線ガードを設置することをおすすめします。空中線の作業をする場合は、空中線の安全スイッチを切ってください。



空中線は人の頭より高い位置に設置してください。

至近距離で直接電波を浴びると人体に影響を及ぼす原因となります。



保守、点検で人がアンテナに接近する場合は指示機の準備/断スイッチを押し、指示機を準備状態にしてください。

至近距離で直接電波を浴びると人体に影響を及ぼす原因となります。

注意



レーダはあくまでも航法援助装置としてご使用ください。

また、操船の最終判断は必ず操船者自身で行ってください。

操船の最終判断を、レーダが表示する情報のみに頼った場合、衝突、座礁等の事故の原因となることがあります。

●Cautions to be used during operation●

WARNING



Do not touch the insides of the scanner unit, transceiver and display unit.

Touching any high voltage area, you will get an electric shock. For maintenance, inspection and adjustment of internal parts of these equipment, consult with our sales office or distributor in your district.



Since the scanner unit radiator rotates, do not approach it.

The scanner unit may start rotating suddenly, and consequently any person may be struck and be injured. We recommend you to install the scanner unit radiator on the roof of the wheel house, flying bridge, trestle, radar mast or any other high position so that no person can approach it. When servicing the scanner unit, set the scanner unit safety button to the OFF position.



Install the scanner unit at any place higher than any person.

If being exposed directly to electric wave at close range, you may suffer adverse influence.



When approaching the antenna for maintenance or inspection, set the power button of the display unit to the ST-BY position.

If being exposed directly to electric wave at close range, you may suffer adverse influence.



CAUTION



Use these radar only as assisting devices for navigation.

Also, the officer should make the final decision for maneuvering by himself.

If you make the final decision of maneuvering only on the information which a radar display, it may become the cause of accidents, such as collision and stranding.

——ご使用前に注意していただきたいこと——

高電圧に対する注意

無線装置、レーダなどの電子機器の内部には数百から数万ボルトの高電圧が使用されています。通常の操作においてはまったく危険はありませんが、万一、誤って機器内部に触れた場合非常な危険を伴います。（専門整備員以外の機器内部の保守・点検・調整は禁止）

数万ボルトの高圧では感電即死の危険が大きく、また時により数百ボルトの電圧でも感電死することがあります。このような危険を防止するには機器の内部に手を入れるとき、必ず電源スイッチを切って、一端を確実に接地した電源でコンデンサーなどを放電させ、電気の残っていないことを確認の上で初めて手を内部に入れるようにしてください。この際、乾燥した木綿の手袋などを用いればなおいっそう危険防止となります。また左手をポケットに入れ、両手を同時に用いないことも必要な注意の一つです。感電したときの障害は二次的に大きくなるがあるので足場もしっかりした所を選ぶことが大切です。感電したときは火傷した所を完全に消毒して、手当を速やかに行う必要があります。

電撃の救出上の注意

電撃を受けた人を発見した場合、直ちに電源を切り回路を接地してください。回路が直ちに切れないときは、感電した人をできるだけ早く乾いた板、布などの絶縁物を介して直接感電した人に触れずに離してください。

感電したとき、頭脳の呼吸中枢に電流が流れると呼吸が急に止まります。衝撃があまりひどくないときは人工呼吸を行うことにより呼吸を回復します。電撃を受けた人は非常に顔色が悪くなり、脈が大変弱くなってしまいか、まったく止まってしまうことがあり、人事不省になり硬直します。

— PRECAUTIONS BEFORE OPERATION —

Cautions for high voltage

High voltages from hundreds volts to tens of thousands volts are to be applied to the electronic equipment such radio and radar devices. You do not face any danger during normal operation, but sufficient cares are required for maintenance, inspection and adjustment of their internal components. (Authorized maintenance personnel alone are permitted to implement maintenance, check-ups or adjustment of internal components.)

High voltages of tens of thousands volts are so dangerous as to bring an instantaneous death from electric shock, but even voltages of hundreds volts may sometimes lead to a death from electric shock. To prevent such an accident, make it a rule to turn off the power button, discharge capacitors with a wire surely earthed on an end and make sure that internal parts are no longer charged before you touch any parts inside these devices. At the time, wearing dry cotton gloves ensures you further to prevent such danger. It is also a necessary caution to put one of your hands in the pocket and not to use your both hands at the same time.

It is also important to select a stable foothold always to prevent additional injuries once you were shocked by electricity. If you were injured from electric shock, disinfect the burn sufficiently and get it taken care of promptly.

What to do in case of electric shock

When finding a victim of electric shock, turn off the power source and earth the circuit immediately. If it is impossible to turn off the circuit, move the victim away promptly using insulators such as dry wood plate and cloth without touching the victim directly.

In case of electric shock, breathing may stop suddenly if current flows to the respiration center in the brain. If the shock is not so strong, artificial respiration may recover breathing. When shocked by electricity, the victim will come to look very bad with weak pulse or without beating, resulting in unconsciousness and rigidity.

救急処置の方法

☆救急処置の留意点

電撃を受けた人を危険のない限り動かさずに、直ちに人工呼吸を行わなければなりません。人工呼吸を始めたらリズムを失わないように続けて行う必要があります。

- (1) 事故の発生であわてて患者に触れないこと（救助者が感電します）。
- (2) あわてず確実に電源を切り患者を静かに電路より離す。
- (3) 周囲の人に知らせる（診療所、病院、医師、119番通報、その他）。
- (4) 患者を仰向けに寝かせネクタイ、衣類、バンドを緩める。
- (5) (イ) 各脈拍に触れてみる。
(ロ) 心臓が動いているか否か心臓に耳を当てて確かめる。
(ハ) 呼吸しているか否か患者の顔へ手の甲または顔を近づけて確かめる。
(ニ) 瞳孔の大きさを調べる。
- (6) 患者の口を開け入歯、煙草、ガムなどを取出し、口を開けたまま舌を伸ばしタオルなどを挿入し舌が喉に引込まれないようにすること（歯をくいしばって口が開かない場合はドライバーなどで開口しタオルなどをかませる）。
- (7) 泡立つ粘液が貯まらないように口をふさぐこと。

FIRST AID TREATMENTS

☆ First-aid treatments

As far as the victim of electric shock is not in dangerous condition, do not move him and practice artificial respiration on him immediately. Once started, it should be continued rhythmically.

- (1) Do not touch the victim confusedly as a result of the accident, but the rescuer may also get an electric shock.
- (2) Turn off the power source calmly and certainly and move the victim away quietly from the electric line.
- (3) Call a physician or ambulance immediately or ask someone to call a doctor.
- (4) Lay the victim on his back and loosen his necktie, clothes, belt, etc.
- (5)
 - a. Examine the victim's pulse.
 - b. Examine his heartbeat bringing your ear close to his heart.
 - c. Examine his breathing bringing the back of your hand or your face close
 - d. Check the size of the pupils of his eyes
- (6) Open the victim's mouth and take out artificial teeth, cigarette or chewing gum if any. Keep his mouth open, stretch his tongue and insert a towel or the like in his mouth to prevent the tongue from suffocating. (If it is hard to open his mouth due to set teeth, open it with a screwdriver and insert a towel in this mouth.)
- (7) Then, close his mouth so that foaming mucus does not accumulate inside.

☆脈拍があり呼吸していない場合の処置

- (1) 患者の顔が後を見る位に顔をそり返らせる（頸部に枕を挿入してもよい）。
- (2) 下顎を上方に引き上げ気道を広げる（気道拡大）。
- (3) 患者の鼻をつまみ、術者は深く息を吸い患者の口を完全に塞ぐようにして強く呼気を吹き込む。
再び口を離して息を大きく吸って吹き込む。
1分間に約10回から15回くり返す（鼻腔を塞ぐこと）。
- (4) 自然に呼吸の起きるのを注意しながら呼吸が戻ったときに止める。
- (5) 開口困難な場合ゴム、ビニールなどのパイプ状のものを鼻腔に挿入して片方の鼻腔と口を完全に塞いで息を大きく吸って吹き込む。
- (6) 患者は気が付くといきなり立つ事がありますが静かに寝かせ、熱いコーヒー、紅茶などを与え暖かくして安静を保つ（アルコール類は与えてはならない）。

頭部をもたげて口うつし人工呼吸を行う方法

- ①  (1) 後頭部をもたげ、片方を額に他の手を頸部の下にあてる。→ ①
多くの患者はこの頭部のもたげにより口が開き空気が通じ、口うつしが容易になる。
- ②  (2) 患者の口をあなたの口で広く封じ、あなたの頬を患者の鼻に押しあてる。→ ②
または、あなたの指で患者の鼻を押さえて空気の漏れを防ぐ。→ ③
- ③  (3) 胸があがるまで口から空気を肺内に吹き込む。
最初の10回の呼気吹き込みはできるだけ急速度で行わなければならない。

図1 口うつし人工呼吸法

★When pulse is beating but breathing has stopped

- (1) Tilt the victim's head back as far as this face looks back. (A pillow may be inserted under his neck.)
- (2) Push his jaw upward to open his throat wide (to spread his airway).
- (3) Pinch the victim's nostrils and take a deep breath, block his mouth completely with yours and blow into his mouth strongly. Take a deep breath again and blow into his mouth. Continue this 10 to 15 times a minute (blocking his nostrils).
- (4) Carefully watch that he has recovered his natural breathing and stop practicing artificial respiration.
- (5) If it is difficult to open the victim's mouth, insert a rubber or vinyl tube into one of his nostrils and blow into it blocking the other nostril and his mouth completely.
- (6) When the victim recovers consciousness, he may try to stand up suddenly, but let him lie calmly and serve him with a cup of hot coffee or tea to keep him warm and quiet. (Never give him alcoholic drinks.)

Method of mouth-to-mouth respiration by raising head

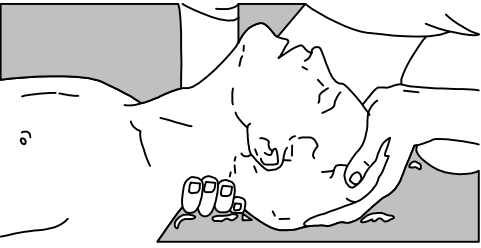
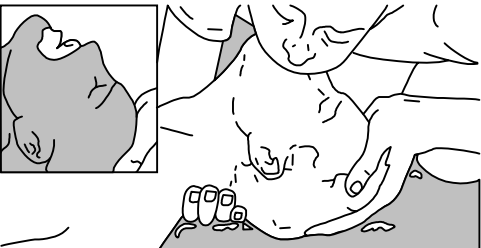
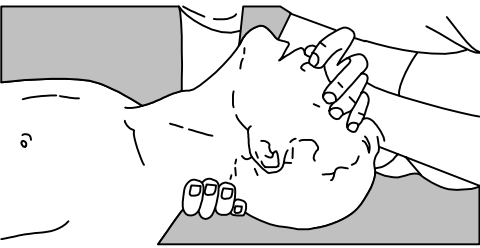
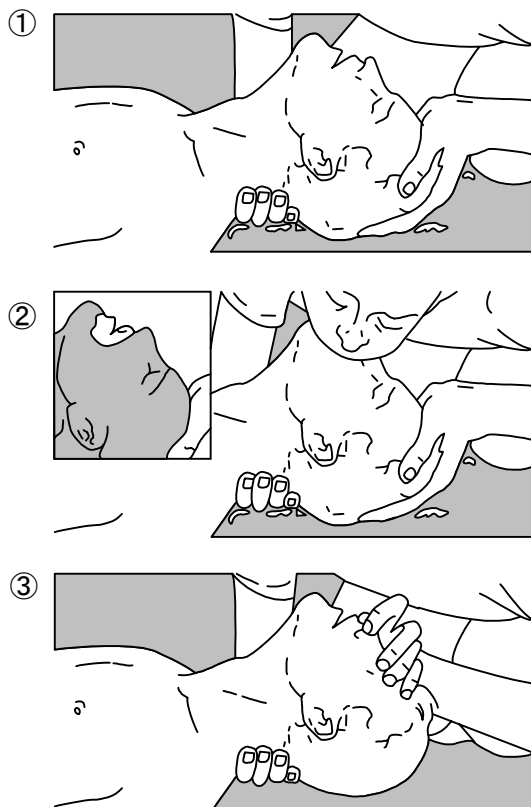

- (1) Raise the victim's head. Support his forehead with one of your hand and his neck with the other hand. → ①
When you tilt his head backward, the victim, in most cases, opens his mouth to the air. This makes mouth-to-mouth respiration easy.
- (2) Cover his mouth as widely as possible with yours and press your cheek against his nose → ②, or, pinch his nostrils with your fingers to prevent air from leaking. → ③
- (3) Blow into his lungs.
Continue blowing into his mouth until his breast swells. Blow into his mouth as quickly as possible for the first 10 times.

Fig.1 Mouth-to-mouth respiration

☆脈拍なく呼吸もしていない場合の処置

脈拍がなく、瞳孔が開き、心臓に耳を当てても鼓動が聞かれない場合は、心臓が停止しているの
で速やかに人工呼吸を行う必要があります。

- (1) 胸骨の下1/3の部位に両手を重ね肘を伸ばして（曲げているとくぼむほど押せません）、術者の体
重をかけ約2cm位くぼむように圧迫する（1分間に約50回位くりかえす）。

（心臓マッサージ法）

- (2) 1人で救急処理を行う場合は、

15回位心臓マッサージを行い速やかに2回呼吸を吹き込む。これをくり返す。

2人で救急処理を行う場合は、

1人が5回心臓マッサージを行い、その間に他の1人が1回呼吸を吹き込む。これをくり返す。

（心臓マッサージ法とろうつし人工呼吸法の併用）

- (3) 時々瞳孔を見たり、脈に触れてみる。瞳孔が正常となり脈も規則正しくなったら、各手当てを中
止して様子を見ながらコーヒー、紅茶などを飲ませ暖かくし安静を保つ。いずれにしても、経過
の判断は専門医に任せる。特に、精神的ショックより早く復帰させるように周囲の理解が必要で
す。



図2 心臓マッサージ法

★When both pulse and breathing have stopped

When no pulse has come not to be felt, his pupils are open and no heartbeat is heard, cardiac arrest is supposed to have occurred and artificial respiration must be performed.

- (1) Place your both hands, one hand on the other, on the lower one third area of his breastbone and compress his breast with your elbows applying your weight on his breast so that it is dented about 2cm (repeat compressing his breast 50 times or so a minute).

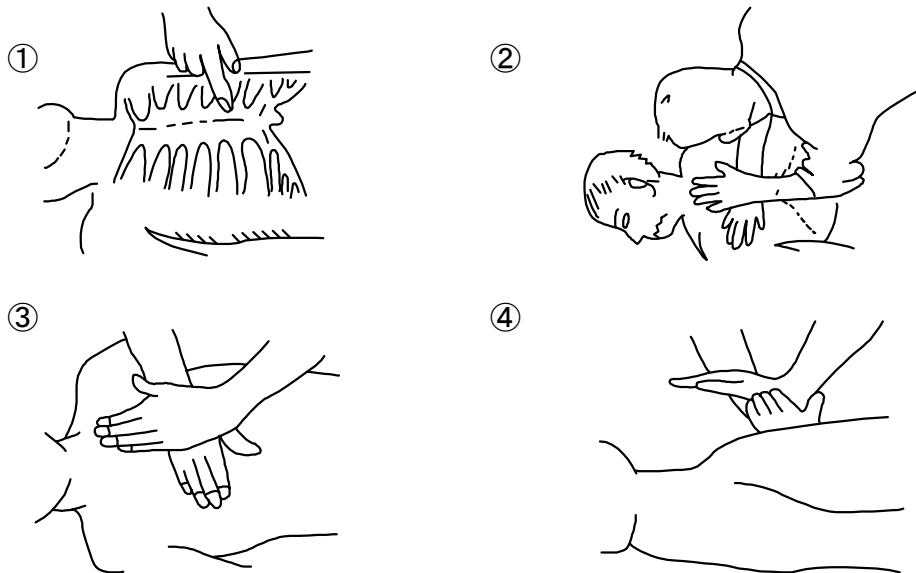
(Cardiac massage)

- (2) **In case of one rescuer,**

Repeat cardiac massages about 15 times and blow into his mouth 2 times quickly, and repeat this combination.

In case of two rescuers,

One person repeats cardiac massages 5 times while the other person blows into his mouth once, and they shall repeat this combination.

(Cardiac massage and mouth-to-mouth respiration)

- (3) Examine his pupils and his pulse sometimes. When the both have returned to normal, stop the artificial respiration, serve him with a cup of coffee or tea and keep him warm and calm while watching him carefully. Commit the victim to a medial specialist depending on his condition. To let him recover from the mental shock, it is necessary for persons concerned to understand his situations and the necessary treatments.

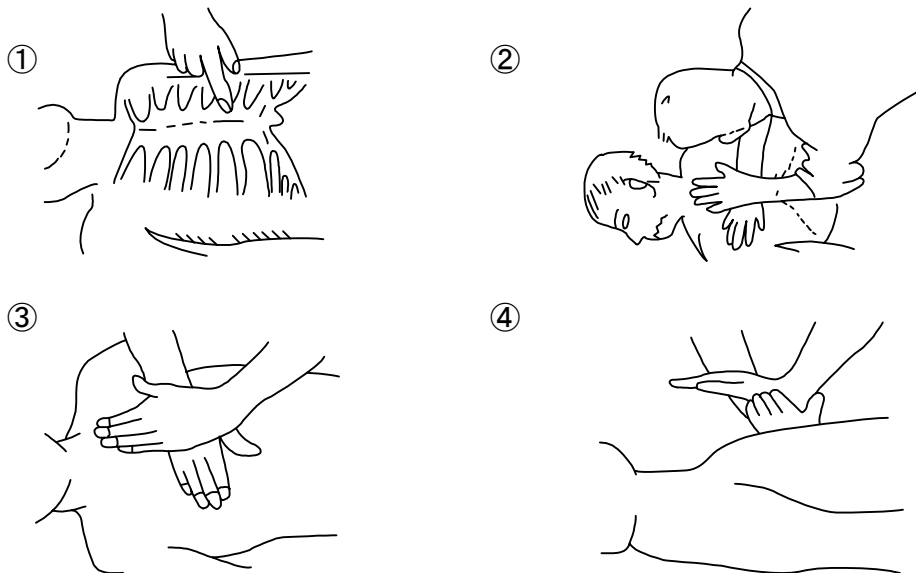

Fig.2 Cardiac massage

機器外觀 EQUIPMENT APPEARANCE



NKE-249形 空中線
Scanner unit Type NKE-249



NKE-250形 空中線
Scanner unit Type NKE-250



NCD-4170形 指示機
Display Unit Type NCD-4170

JMA-2343
2344

INSTRUCTION MANUAL

[English edition]

Contents

PREFACE	I
Before Operation	III
Cautions to be used during operation	V
PRECAUTIONS BEFORE OPERATION	VII
Cautions for high voltage	VII
What to do in case of electric shock	VII
FIRST AID TREATMENTS	IX
☆First-aid treatments	IX
☆When pulse is beating but breathing has stopped	XI
☆When both pulse and breathing have stopped	XIII
EQUIPMENT APPEARANCE	XIV
Glossary of Radar Terms	144
Chapter 1 Introduction	145
1.1 Function	145
1.2 Features	145
1.3 Composition	146
1.4 Configuration	147
1.5 General System Diagram	150
Chapter 2 Names and Functions of Control Panel Parts and Menu Composition	152
2.1 Functions of the Front Control Panel Keys	152
2.1.1 Functions of the front control panel keys	152
2.1.2 Composition and functions of the soft key switches	153
2.1.3 Functions of the cross key	154
2.2 Explanation of Screen Readout	156
2.3 Explanation of Functions within the Menu	158
2.3.1 Menu Composition	158
2.3.2 Functions within the menu	160
Chapter 3 Basic Operations	164
3.1 Flow of Operations	164
Soft key operation	165
3.1.1 Turning the power ON and starting the system	166
1. Turning the power ON	166

2. Undertake transmission	166
3.1.2 Tuning operation	166
3.1.3 Adjusting monitoring and image	167
3.1.4 Data acquisition and monitoring	167
3.1.5 Ending the operation and shutting down the system	167
1. Interrupting the transmission	167
2. Shutting the power off	167
3.2 Monitoring Standby	168
3.2.1 Changing the brightness of the screen	168
3.2.2 Changing the brightness of the control panel lighting	168
3.2.3 Switching among display languages	168
3.2.4 Setting the buzzer volume	168
3.3 Basic Operations	169
3.3.1 Transmitting	169
3.3.2 Interrupting transmission	169
3.3.3 Changing the range (scale of distance)	169
3.3.4 Erasing and displaying the fixed range ring	169
3.3.5 Erasing ship's heading marker	170
3.3.6 Adjusting the tuning	171
3.3.7 Adjusting the sensitivity	171
3.3.8 Eradicating radar interference	172
3.3.9 In the event of rain or snow	173
3.3.10 In case of high waves	174
3.3.11 Measuring the range to the target	175
1. Using VRM	175
Measuring the distance from the ship using #1VRM	175
Setting whether or not use of #2VRM is enabled	175
Operating the #1VRM/#2VRM	175
Erasing the #1VRM and #2VRM	176
2. Moving the center of the VRM	176
3. Changing the interval between the parallel line cursors	176
4. Using the cross hair cursor	176
3.3.12 Changing the range unit	177
3.3.13 Measuring the bearing of a target	177
1. Using EBL	178
Measuring the distance from the ship using #1EBL	178
Setting whether or not use of #2EBL is enabled	178
Operating the #1VRM/#2VRM	178
Erasing the #1EBL and #2EBL	179
2. Moving the center of the EBL	179

3.	Changing the interval between the parallel line cursors	179
4.	Using the cross hair cursor	179
3.3.14	Floating VRM and EBL	180
	Setting the #1EBL and #1VRM to enable moving	180
	Setting the point of reference and center position	180
	Operating the EBL and VRM	180
	Canceling the point of reference or center position	180
3.3.15	Using the parallel line cursor	181
	The parallel line cursor function is set to #1EBL and #1VRM	181
	Operating the parallel line cursor	181
	Canceling the parallel line cursor	181
3.3.16	Switching the EBL and cursor bearing display among relative, true and magnetic bearing display mode	181
	Selection of bearing criteria (magnetic bearing, gyrocompass bearing)	183
	Selection of the bearing criteria	183
3.3.17	Changing the bearing display method of the PPI screen	183
	Course setting in course-up mode	185
3.3.18	Simultaneously measuring the bearing, distance and travel time to the target	185
	Displaying cursor	186
	Moving the cursor	186
	Erasing the cursor	186
3.3.19	L/L display of the cursor	187
3.3.20	Magnifying the echo images on the PPI screen	187
1.	Using the image expansion function	187
2.	Changing the transmission pulse width	188
3.	Using the zoom function	189
	Setting the zoom area	189
	Canceling the zoom	190
3.3.21	Reducing unnecessary noise and emphasizing the target	190
	Set the image processing	190
	Canceling image processing	191
3.3.22	Moving the center of the PPI screen	191
	Setting the position to which the center is relocated.	191
	Canceling center relocation	192
3.3.23	Controlling power consumption of the radar	192
	Setting the transmission time	192
	Setting the standby time	192
	Commencing timed transmission	192
	Canceling timed transmission	193
	Canceling timed transmission while in standby mode	193

3.3.24	Locking a fixed target on the radar PPI screen while the ship is navigating	194
	Commencing True Motion display	194
	Canceling true motion display	195
3.3.25	Monitoring the motion of other ships (Targets)	197
1.	Radar display of wake	197
	Commencing radar display of a wake	197
	Ending radar display of a wake	197
2.	Using the lookout alarm	197
	Setting the guard zone	197
	Changing the alarm mode	199
	Eradicating the guard zone	199
	Calling a guard zone	199
	Changing the sensitivity of the alarm	199
3.4	Other Convenient Functions	200
3.4.1	Displaying the ship's speed on the display unit	200
3.4.2	Displaying the ship's heading on the display unit	200
3.4.3	Displaying position information (latitude/longitude, LORAN C time difference) of the ship and waypoint information (latitude/longitude)	201
	Display of position information	201
	Erasing location information	201
3.4.4	Displaying the waypoint	202
	Display of the waypoint	202
	Erasing the waypoint	202
3.5	Miscellaneous Considerations	203
3.5.1	Replacing the battery (BT1)	203
3.5.2	In cases of abnormality during operations	204
3.6	External Navigation Devices	205
3.6.1	Obtaining information on bearing	205
3.6.2	Obtaining information on speed	205
3.6.3	Obtaining information on position	205
3.6.4	Obtaining information on distance to the waypoint	206
Chapter 4 How to Interpret the PPI Screen		207
4.1	Height of and the Distance to the Target	207
4.2	Returns from a Target	208
4.3	Propagation Path of Radio Waves	208
4.3.1	Sea returns	209
4.3.2	False echoes	209
4.4	Display of Radar Transponder	211

Chapter 5 Maintenance and Inspection	212
5.1 General Maintenance	212
5.2 Scanner Unit	213
5.3 Display Unit	213
5.4 Special Parts	214
5.5 Circuit Blocks for Repair	214
5.6 Actions to Deal with Abnormalities and Breakdown	216
Chapter 6 After-sales Service	218
Chapter 7 Disposal	220
7.1 Equipment Disposal	220
7.2 Disposal of Used Batteries	220
7.3 Disposal of Used Magnetron	220
Chapter 8 Specifications	221
8.1 General	221
8.2 Scanner Unit (NKE-249/250)	222
8.3 Display Unit (NCD-4170)	224
8.4 Rectifier Unit (NBA-797A)	228
8.5 Unit-to-unit Spacing	228
Chapter 9 Installation	229
9.1 General	229
9.2 Installing the Scanner Unit	230
9.2.1 Selecting the installation location	230
9.2.2 Installation procedure	230
9.2.3 Connection of cables to be assembled	233
9.3 Installing the Display Unit	236
9.3.1 Selecting the installation location	236
9.3.2 Installation procedure	236
9.3.3 Connecting the power cable	236
9.3.4 Display unit rear panel	237
9.3.5 Connection of the external buzzer	238
9.3.6 Connecting an electromagnetic compass	240
9.4 Modifications to be Made to the Inboard Power Supply	241
1. Display unit	241
2. Scanner unit	241
9.5 Cable Assemblies	242
9.5.1 Inter-unit cable (CFQ6774-10/15/20, CFQ6882-10/15/20)	242

9.5.2	Power cable (CFQ-6776)	243
9.5.3	Selecting a long cable	243
9.6	After-installation Adjustments	244
9.6.1	Installation-time check	244
9.6.2	Functional checks	244
9.6.3	Adjustment items	244
9.6.4	Rectifier unit	245
9.7	Adjustment Procedures	246
9.7.1	General adjustments	246
1.	Adjustments to be made when a part is replaced	246
2.	CRT monitor off center adjustment	246
3.	Adjusting the brilliance level of the CRT monitor screen.	246
4.	Adjusting the focus of the CRT monitor screen	246
9.7.2	Adjusting the scanner unit	247
1.	Adjusting the AVR output voltage from the modulator	247
2.	Adjusting the tuning indicator level of the receiver	247
9.7.3	Adjusting the display unit	247
1.	Adjusting the brilliance level	247
2.	Adjusting the focus of the CRT monitor screen	247
3.	Adjusting the tilt angle of the display unit	248
4.	Adjusting the CRT display	248
5.	Adjusting the AVR output voltage	248
9.8	Initial Settings	249
9.8.1	Adjustment of the receiver	250
1.	Tune preset	250
2.	Adjusting the central frequency	251
3.	Adjusting the level of the tune level indicator	251
9.8.2	Adjusting the noise level	252
9.8.3	Adjusting the bearing	252
9.8.4	0 NM adjustment (Initial setting of distance)	253
9.8.5	Setting the antenna height	254
9.8.6	Presetting the sensitivity	255
9.8.7	Presetting the sea clutter	255
9.8.8	Suppression of main bang	256
9.8.9	Display of simulator image	257
9.8.10	Setting the TD reception number	258
9.8.11	GPS/DGPS	259
1.	Initial setting of GPS	259
2.	Initial setting of DGPS	259
3.	Status of reception of GPS and DGPS	260

9.9	Returning to the Initial Setting Conditions	264
9.10	Maintenance	265
9.10.1	General maintenance	265
1.	Cleaning	265
2.	Screw inspection	265
3.	Cabling check	265
9.10.2	Scanner unit	266
1.	Radiation unit	266
2.	Rotary drive block (JMA-2344)	267
9.10.3	Display unit	268
	Cleaning the Display Unit Screen	268

Attached Figures

- 【Fig. 101 INTERCONNECTION DIAGRAM OF JMA-2343】
- 【Fig. 102 INTERCONNECTION DIAGRAM OF JMA-2344】
- 【Fig. 103 POWER SUPPLY DIAGRAM OF JMA-2343】
- 【Fig. 104 POWER SUPPLY DIAGRAM OF JMA-2344】
- 【Fig. 105 INTERNAL CONNECTIONS OF SCANNER UNIT NKE-249】
- 【Fig. 106 INTERNAL CONNECTIONS OF SCANNER UNIT NKE-250】
- 【Fig. 107 CIRCUIT DRAWING OF MODULATOR UNIT CME-307】
- 【Fig. 108-1 CIRCUIT DRAWING OF RECEIVER UNIT CAE-457 (1/2)】
- 【Fig. 108-2 CIRCUIT DRAWING OF RECEIVER UNIT CAE-457 (2/2)】
- 【Fig. 109 CIRCUIT DRAWING OF MODULATOR UNIT CME-308】
- 【Fig. 110-1 CIRCUIT DRAWING OF RECEIVER UNIT CAE-457-1 (1/2)】
- 【Fig. 110-2 CIRCUIT DRAWING OF RECEIVER UNIT CAE-457-1 (2/2)】
- 【Fig. 111 INTERNAL CONNECTIONS OF DISPLAY UNIT NCD-4170】
- 【Fig. 112-1 CIRCUIT DRAWING OF MAIN CONTROL UNIT CMC-1156 (1/4)】
- 【Fig. 112-2 CIRCUIT DRAWING OF MAIN CONTROL UNIT CMC-1156 (2/4)】
- 【Fig. 112-3 CIRCUIT DRAWING OF MAIN CONTROL UNIT CMC-1156 (3/4)】
- 【Fig. 112-4 CIRCUIT DRAWING OF MAIN CONTROL UNIT CMC-1156 (4/4)】
- 【Fig. 113 CIRCUIT DRAWING OF SOFT KEY PANEL UNIT CCK-872】
- 【Fig. 114 CIRCUIT DRAWING OF MAIN PANEL UNIT CCK-873】
- 【Fig. 115 CIRCUIT DRAWING OF POWER SUPPLY UNIT CBD-1596】
- 【Fig. 116 CIRCUIT DRAWING OF CRT MONITOR UNIT】
- 【Fig. 117 BLOCK DIAGRAM OF SCANNER UNIT】
- 【Fig. 118 BLOCK DIAGRAM OF DISPLAY UNIT】

Glossary of Radar Terms

A/D	Analog to Digital conversion
ACQ	Acquisition
A-SEA	Automatic Sea surface clutter suppression
A-RAIN	Automatic Rain and snow clutter suppression
A-TUNE	Automatic Tuning
CPU	Central Processing Unit
CRT	Cathode-ray Tube
CUP	Course-Up
EBL	Electronic Bearing Line
EXP	Expansion
FTC	Fast Time Constant, also known as Rain and snow clutter suppression
GPS	Global Positioning System
HUP	Head-Up
IR	Interference Rejection
L/L	Latitude/Longitude
MARPA	Mini Automatic Radar Plotting Aid
MH	Modulator High Voltage
MOB	Man Over Board
NM	Nautical Mile
NUP	North-Up
PCB	Printed Circuit Board
PPI	Plan Position Indicator
PROCESS	Process
PW	Pulse Width
RR	Range Rings (Fixed)
RM	Relative Motion
SHM	Ship's Heading Marker
STBY	Standby
STC	Sensitivity time control, also known as Sea surface clutter suppression
TD	Time Difference
TM	True Motion
TI	Trigger
VCT	Vector
VD	Video
VRM	Variable Range Marker
WPT	Waypoint
X-MIT	Transmit

1 Introduction

1.1 *Function*

The JMA-2243/2344 series radar devices are marine radar devices that use scanner units including transmitter and receiver and 10 inch monochrome cathode-ray tube utilizing the compact raster scan method for achieving a fully semi-conductor adopted (excluding special electron tubes) system.

This equipment comprises radar as defined in the Wireless Telegraphy Act.

1.2 *Features*

Enhanced fundamental performance of the radar

Through switching among 4 steps in terms of pulse width/cycle switching of frequency and switching among 3 steps in receiver bandwidth, enhanced fundamental performance of the radar has been achieved towards display of clearer and higher quality images. Moreover, through the incorporation of advanced digital signal processing, performance in target detection during increment weather has been improved.

Confirmation of the ship's position and identifying the waypoint at a glance

Through connecting to navigation equipment such as GPS, the location of the ship (numerical value) or a mark on the waypoint may be displayed on the screen and through this, the difference between the bearing of the waypoint and the ship's heading may be grasped at a glance.

High operability

EBL and VRM that are frequently used are equipped with dedicated switches. Moreover, 4 soft key switches have been incorporated and functions that are relatively frequently used may be operated with ease. Additionally, a system for selecting functions that are infrequently used from the menu has been adopted.

1.3 Composition

Composition of the Radar and Ship Internal Power Source

Comprehensive type	Scanner unit	Display unit	Ship internal power source
JMA-2343 JMA-2344	NKE-249 NKE-250	NCD-4170	DC (12V/24V/32V) or AC ^(Note) (100V/110V/115V/ 200V/220V/230V) 50/60Hz single phase

Rectifier type (option)	NBA-797A
-------------------------	----------

(Note) When AC power source is used, the optional rectifier is required.

Accessories

Product Name	Quantity	JRC Code	Remarks
Instruction Manual	1	7ZPRD0558	This manual
Cable between the scanner unit and display unit	1	CFQ6774-15 (JMA-2343)	10 core composite cable 15m
		CFQ6882-15 (JMA-2344)	14 core composite cable 15m
Power cable assembly	1	CFQ-6776	2m
Sun shield	1	MTV303344	—

Standard spare parts kit (7ZXRD0008)

Product name (type)	Quantity	JRC Code	Remarks
Fuse (SB3.15)	2	5ZFAD00382	(for 24/32V) 3.15A
Fuse (SB6.3)	3	5ZFAD00540	(for 12V) 6.3A
Fuse (SB5)	2	5ZFAD00364	(for 24/32V) 5A
Fuse (SB10)	3	5ZFAD00539	(for 12V) 10A

Optional

Product Name	Quantity	JRC Code	Remarks
Cable between the scanner unit and display unit	1	CFQ6774-10 (JMA-2343)	10 core composite cable 10m
		CFQ6774-20 (JMA-2343)	10 core composite cable 20m
		CFQ6882-10 (JMA-2344)	14 core composite cable 10m
		CFQ6882-20 (JMA-2344)	14 core composite cable 20m

1.4 Configuration

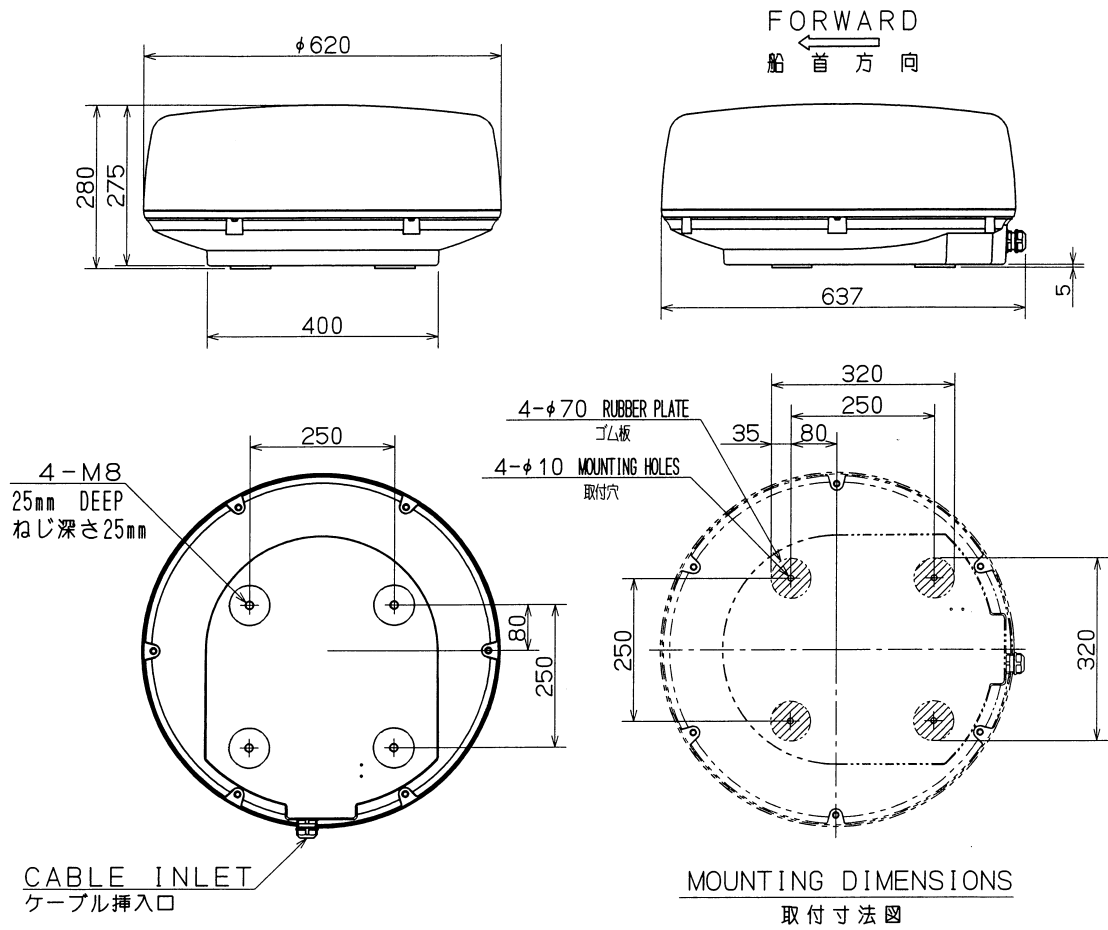

COLOR	WHITE
MASS	APPROX. 10.5kg
UNIT	mm

筐体色	白
質量	約 10.5kg
単位	mm

Fig. 1.1 OUTLINE DRAWING OF SCANNER UNIT NKE-249

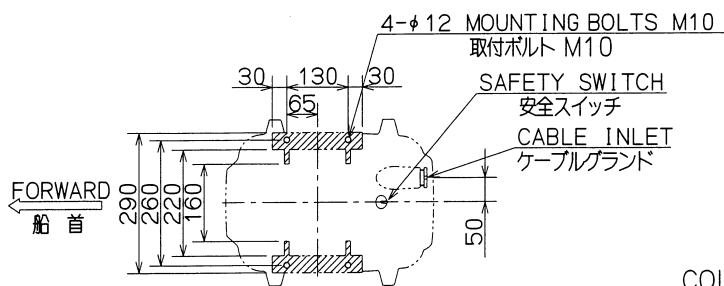
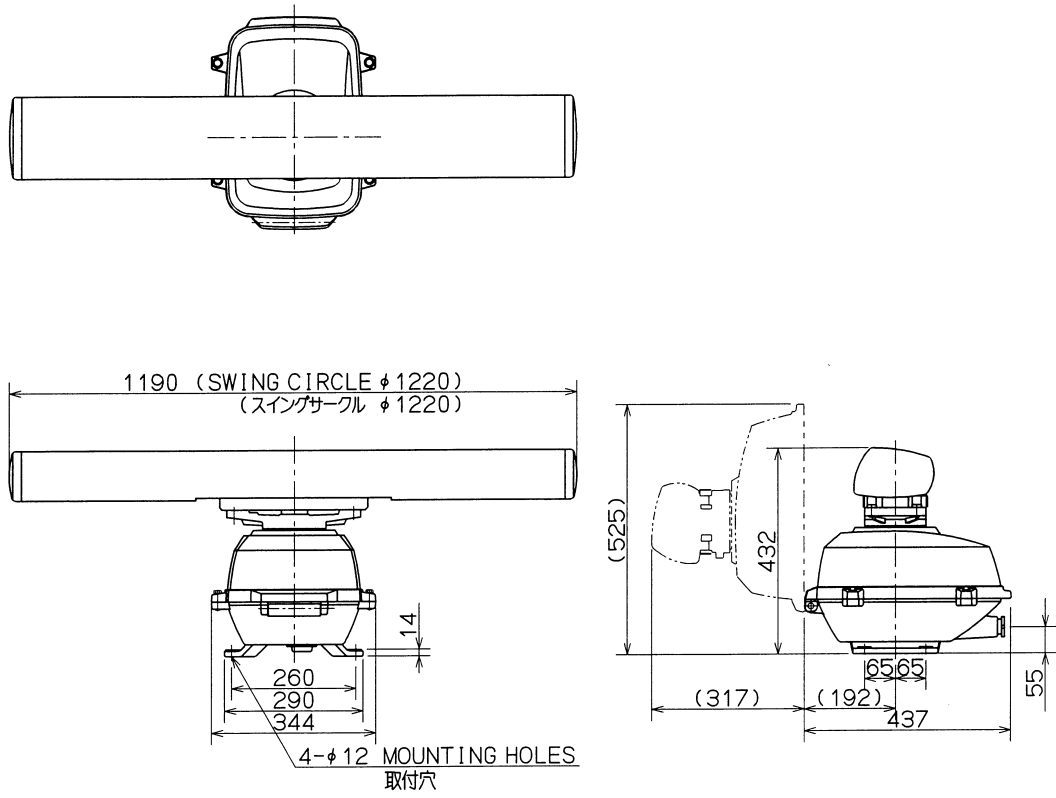

MOUNTING DIMENSIONS
取付寸法図

COLOR	WHITE
MASS	APPROX. 24kg
UNIT	mm

管体色	白
質量	約 24kg
単位	mm

Fig. 1.2 OUTLINE DRAWING OF SCANNER UNIT NKE-250

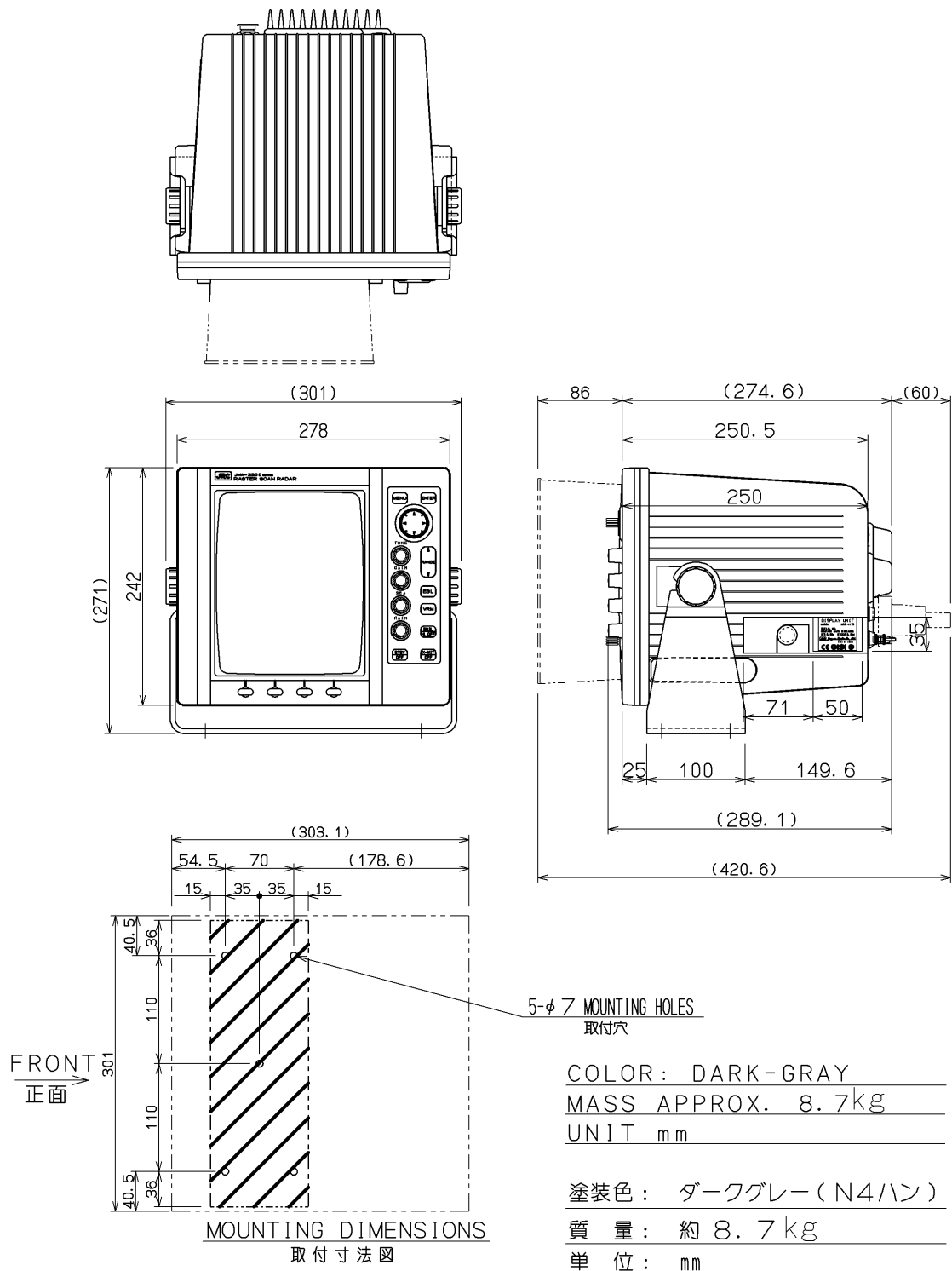
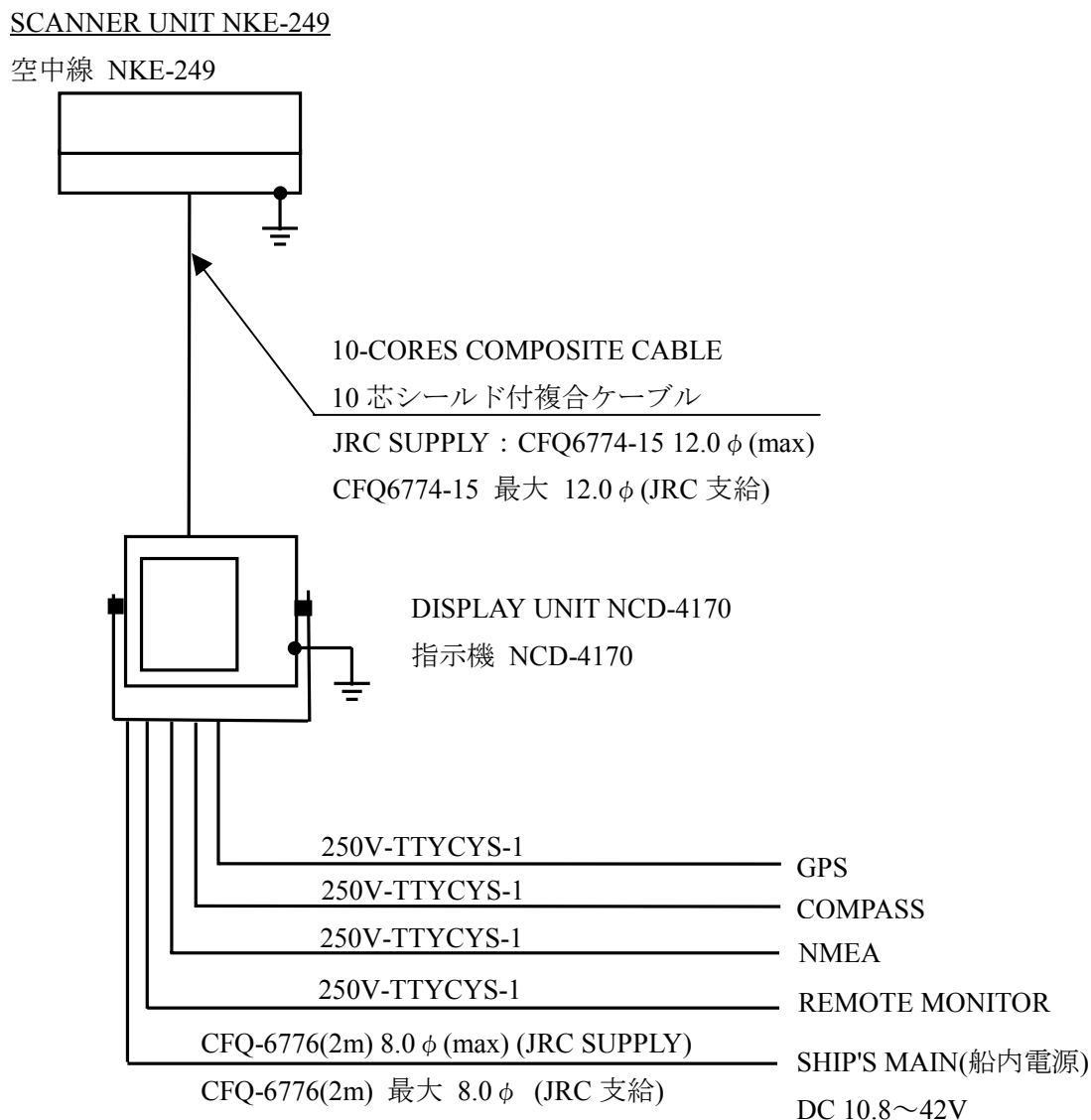

Fig. 1.3 OUTLINE DRAWING OF DISPLAY UNIT NCD-4170

1.5 General System Diagram



NOTES :

ELIMINATING THE INTERFERENCE ON FREQUENCIES USED FOR MARINE COMMUNICATIONS AND NAVIGATION DUE TO OPERATION OF THE RADAR.

ALL CABLES OF THE RADAR ARE TO BE RUN AWAY FROM THE CABLES OF RADIO EQUIPMENT. (EX. RADIOTELEPHONE.COMMUNICAITONS RECEIVER AND DIRRECTION FINDER.ETC.)

ESPECIALLY INTER-WIRING CABLES BETWEEN SCANNER UNIT AND DISPLAY UNIT OF THE RADAR SHOULD NOT BE RUN PARALLEL WITH THE CABLES OF RADIO EQUIPMENT.

ご注意

レーダの動作が他の無線装置に、雑音妨害を与えることを防止するために、レーダケーブル、特に空中線ケーブルを他の無線装置のケーブルと平行に設置しないでください。

Fig. 1.4 GENERAL SYSTEM DIAGRAM OF JMA-2343

SCANNER UNIT NKE-250

空中線 NKE-250

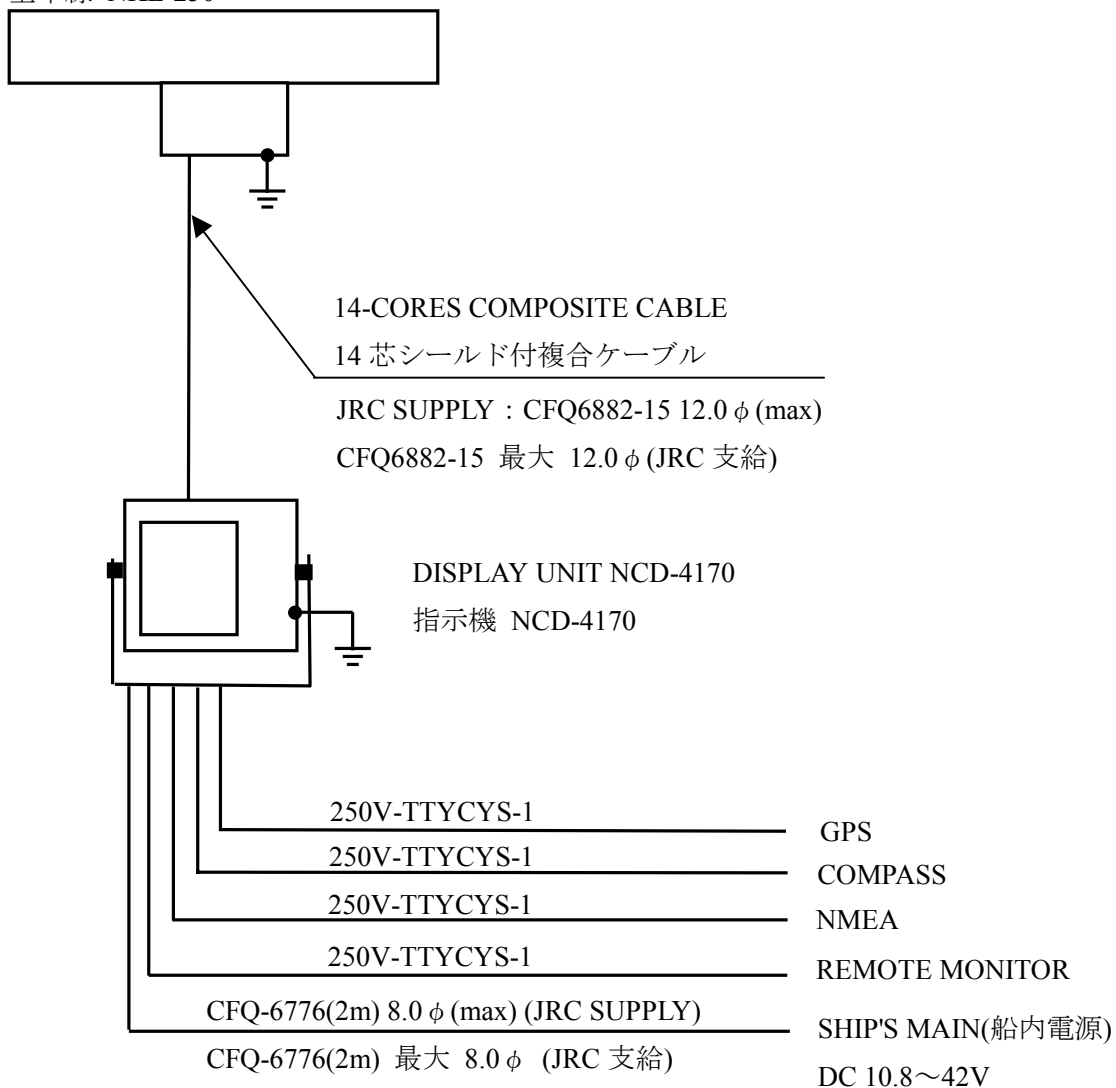

NOTES :

ELIMINATING THE INTERFERENCE ON FREQUENCIES USED FOR MARINE COMMUNICATIONS AND NAVIGATION DUE TO OPERATION OF THE RADAR.

ALL CABLES OF THE RADAR ARE TO BE RUN AWAY FROM THE CABLES OF RADIO EQUIPMENT. (EX. RADIOTELEPHONE, COMMUNICATIONS RECEIVER AND DIRECTION FINDER, ETC.)

ESPECIALLY INTER-WIRING CABLES BETWEEN SCANNER UNIT AND DISPLAY UNIT OF THE RADAR SHOULD NOT BE RUN PARALLEL WITH THE CABLES OF RADIO EQUIPMENT.

ご注意

レーダの動作が他の無線装置に、雑音妨害を与えることを防止するために、レーダケーブル、特に空中線ケーブルを他の無線装置のケーブルと平行に設置しないでください。

Fig. 1.5 GENERAL SYSTEM DIAGRAM OF JMA-2344

2 Names and Functions of Control Panel Parts and Menu Composition

2.1 Functions of the Front Control Panel Keys

Normal operations with respect to this radar equipment may be undertaken from the front panel of the display. Moreover, by using functions that are defined by the menu, the operator may make full use of the functions of this equipment.

While the operations are simple, in order to display the necessary information on the cathode-ray tube, it is important that the operator has full understanding of the functions of the various operations.

2.1.1 Functions of the front control panel keys

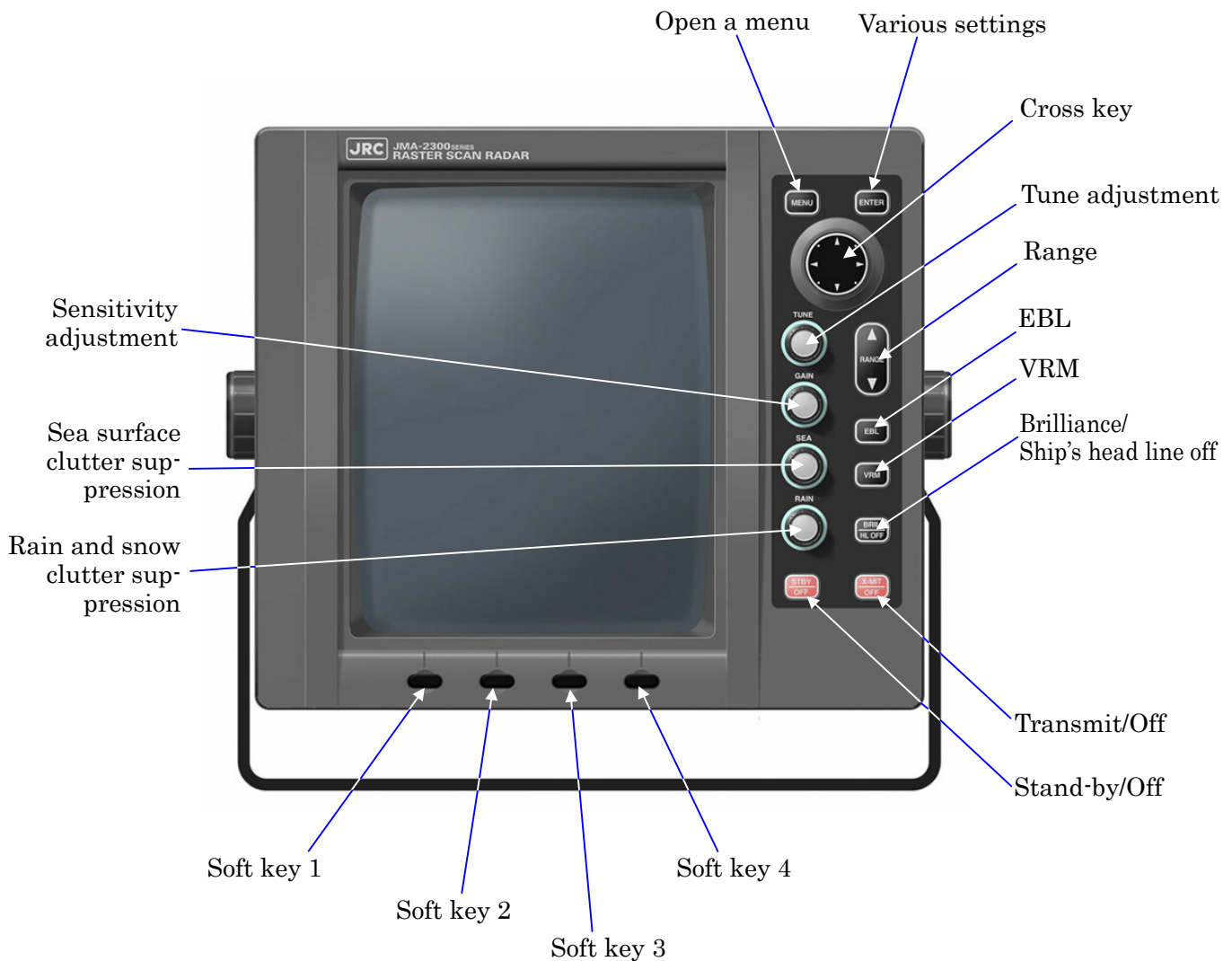

2.1.2 Composition and functions of the soft key switches

In order to simplify operations, this equipment is equipped with 4 soft key switches on the front panel. The optional items corresponding to each soft key is displayed at the lowermost part of the screen and the function may be executed by pushing the corresponding key.

The soft key menu is comprised as follows.

Key1

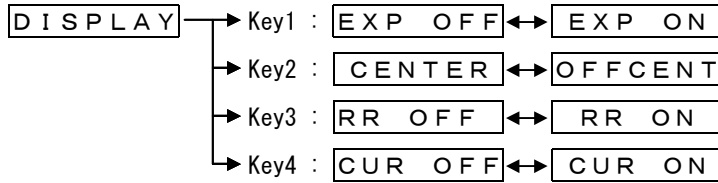

Key2

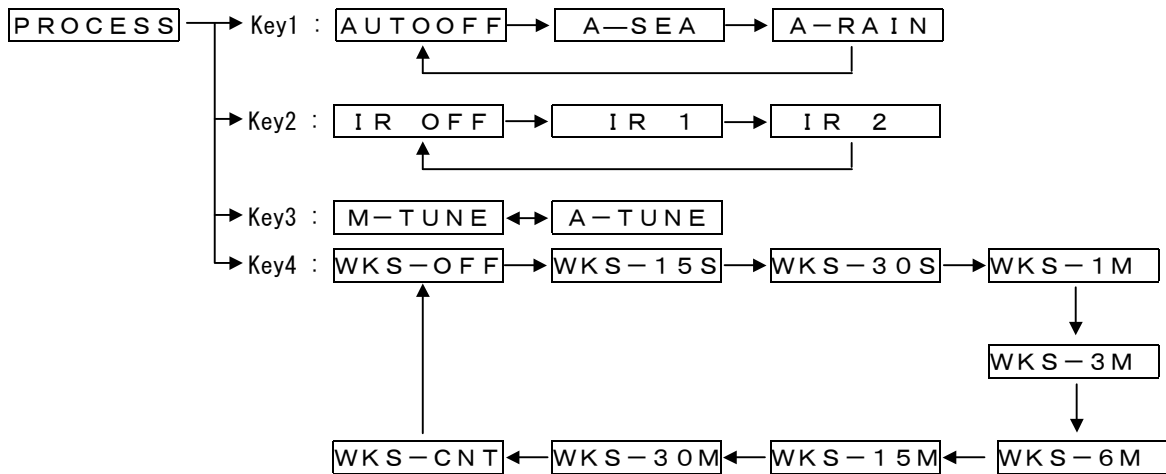

Key3

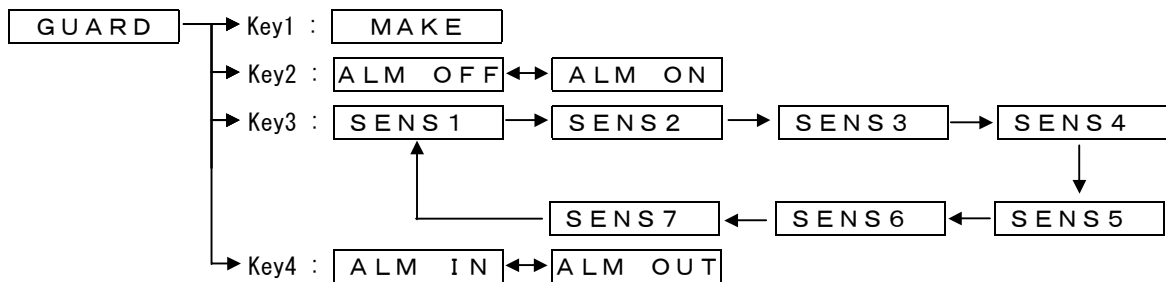

2.1.3 Functions of the cross key

The cross key is used to move the cross cursor, rotate the EBL, change the size of the VRM and select items from the menu. By pushing the cross key, the cursor moves in the direction pushed and the EBL may be rotated.

The cross key is used to activate the following functions.

Dedicated key operations

VRM

、

EBL

、

MENU

Soft key operations

OFF	CENT
-----	------

、

CUR	ON
-----	----

、

GUARD	MAKE
-------	------

Menu operations

MENU	FUNCTION	ZOOM	SET
------	----------	------	-----

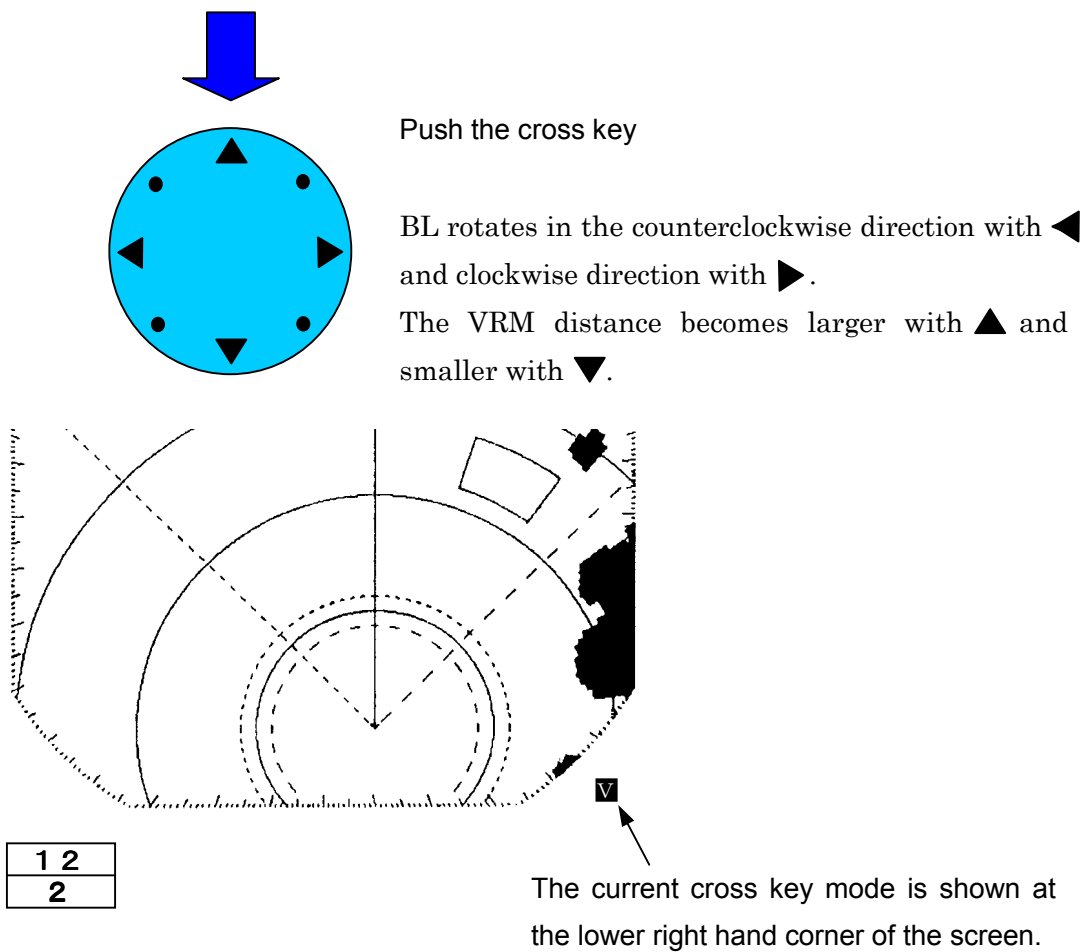

Use	Mode Name	Letter on Screen of Lower Reight Corner
Enables a EBL	EBL mode	E
Enables a VRM	VRM mode	V
Enables a F EBL/VRM	F EBL/VRM mode	F
Enables the parallel line mode	Parallel line mode	P
Enables the cursor	Cursor mode	C
Enables the off center mode	Off center mode	O
Enables the zoom mode	Zoom mode	Z
Enables the guard mode	Guard mode	G
Enables the menu mode	MENU mode	M

2.2 Explanation of Screen Readout

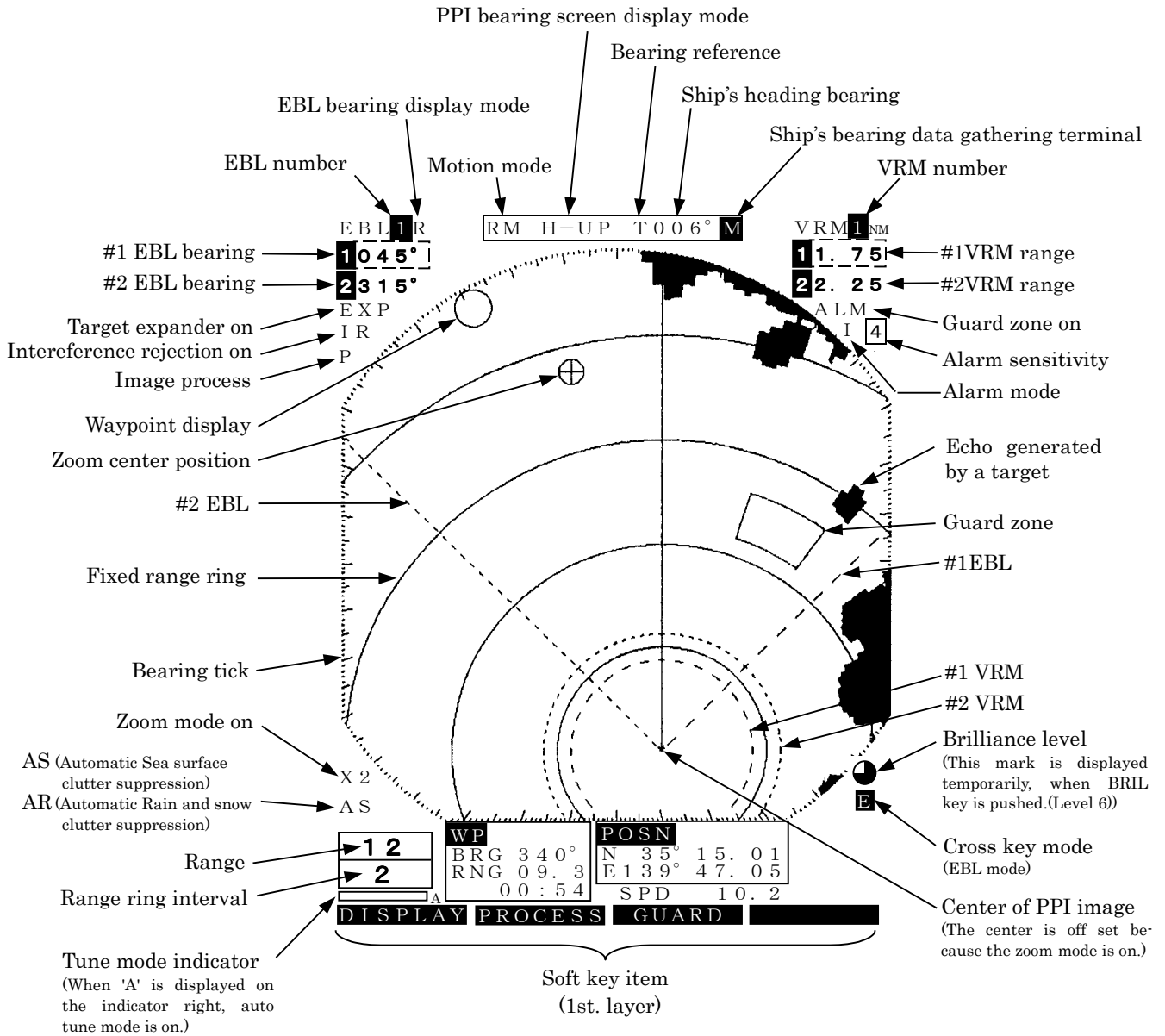

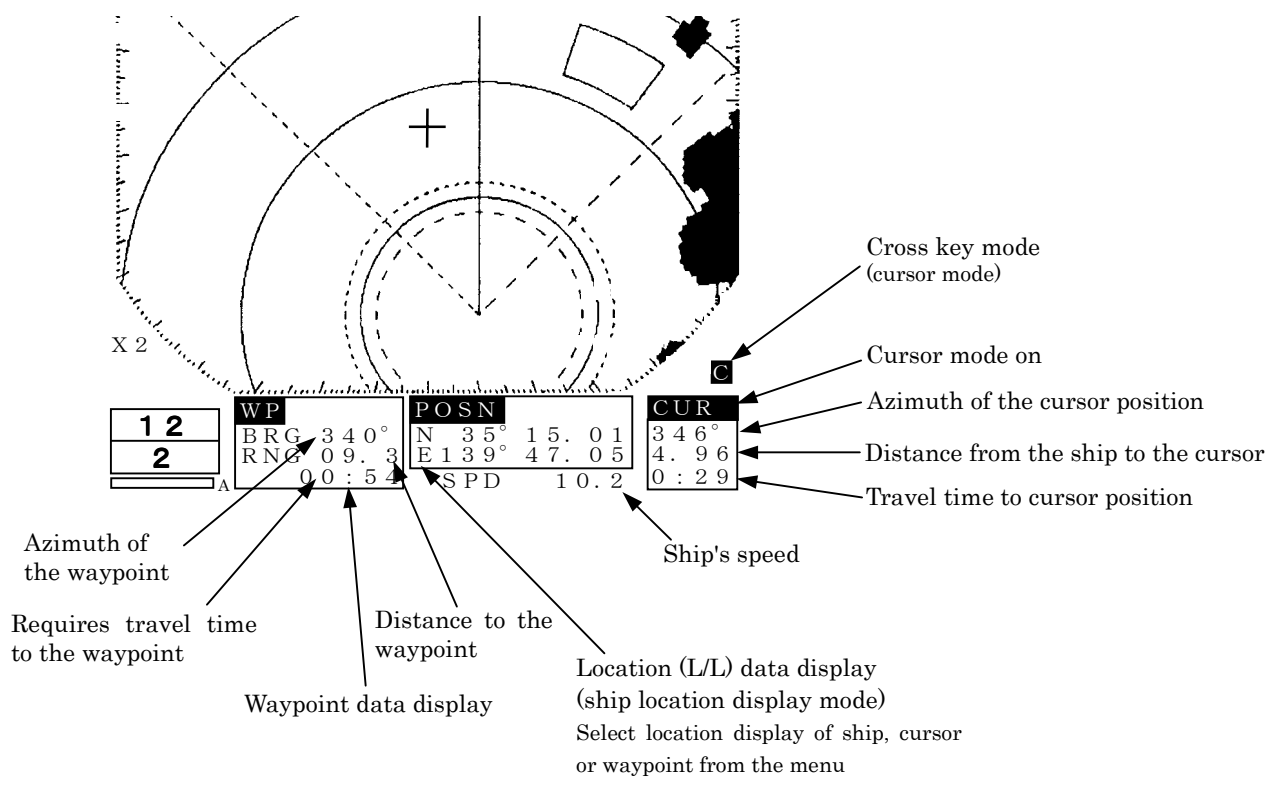

2.3 Explanation of Functions within the Menu

This radar equipment has, in addition to the capability of operating using the front panel keys (including the soft key), the following operating functions. In this section, the composition, function and method of setting the menu will be explained.

2.3.1 Menu Composition

With this radar equipment, it is possible to switch the screen display from the Japanese language, to the English language and to other languages (Chinese, French, Spanish, Italian, Norwegian, German and Korean).

● Please refer to "3.2.3 Switching Language Display" for the switching among languages.



2.3.2 Functions within the menu

When using functions marked with [*], connectivity to an external navigation system is required.

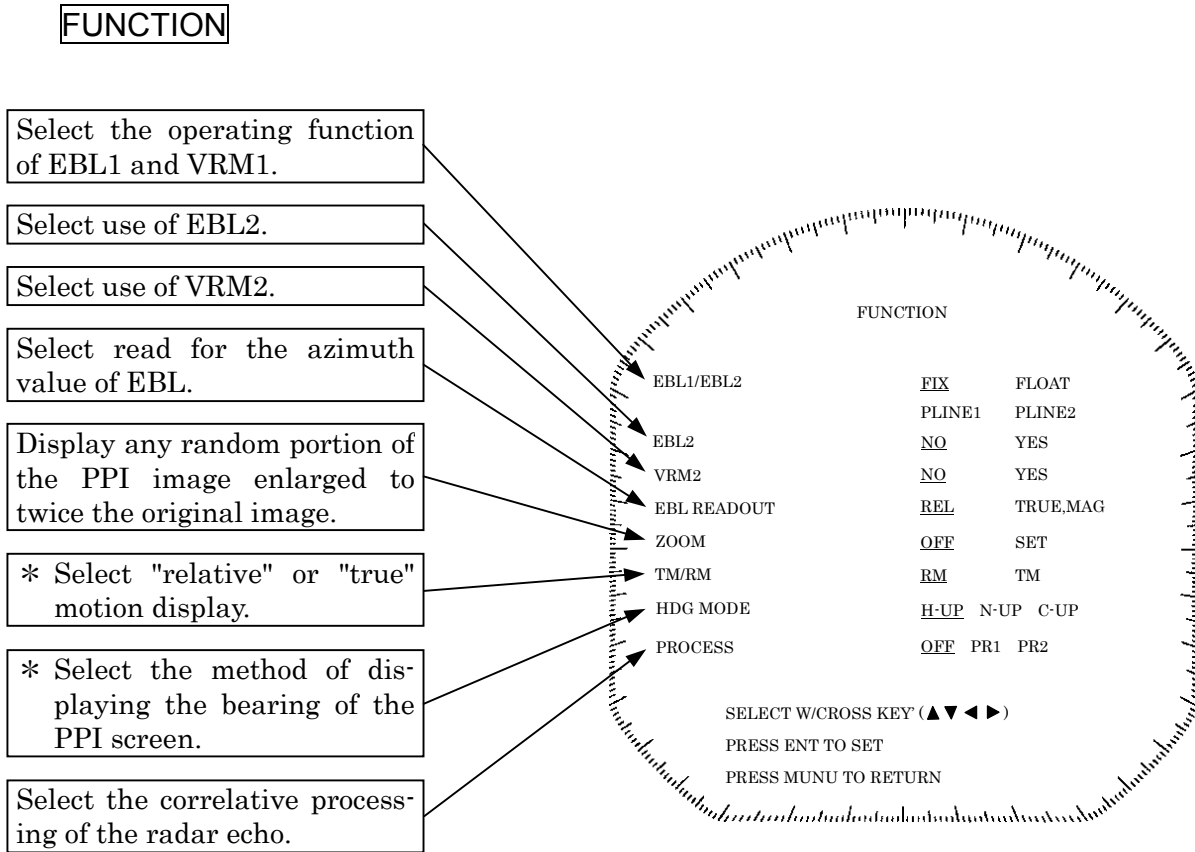

DISPLAY

* Select the information to be displayed on the screen from the positional information of the ship's heading (latitude/longitude; L/L or time difference; TD) or the location information of the waypoint.

* Display the waypoint on the PPI screen.

Select the units for the distance measured by the VRM or cursor.

NM : Nautical miles
 KY : Kilo yards
 KM : Kilometers

For energy saving purposes, transmission mode and standby mode are automatically switched.

The duration of the transmission mode time is set based on the rotation of the scanner unit.

Set the duration of the standby time.

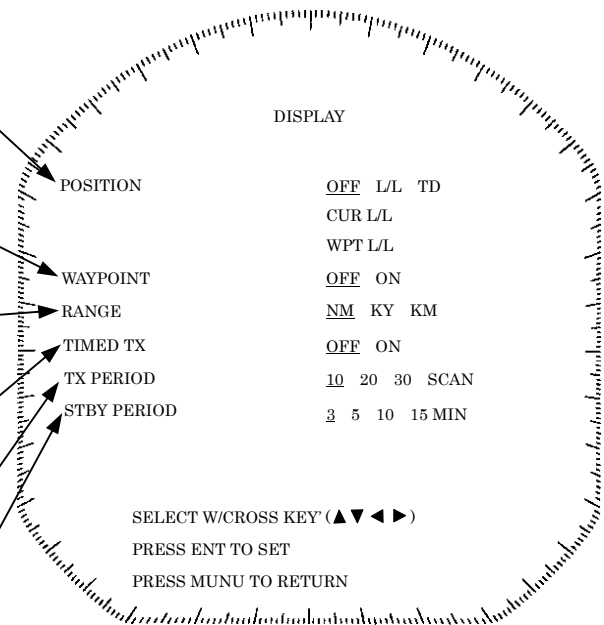

RADAR SET-UP 1

Set the buzzer sound.
The sound becomes louder as the value becomes larger.

Set the lighting of the operation panel.
The panel becomes brighter as the value becomes larger.

Set the pulse width.
Settings may be selected from 1.5NM, 3NM or 6NM.

- The smaller the width, the greater the resolution will be.
- The wider the width, the greater the sensitivity will be.

Select the azimuth data to be adopted.

RADAR SET-UP 1

BUZZER	0	1	2	3	<u>4</u>	5	6	7
DIMMER	0	1	2	3	<u>4</u>	5	6	7
TX PULSE								
(1.5NM)	<u>0.08</u>	0.25	μ s					
(3NM)	<u>0.25</u>	0.5	μ s					
(6NM)	<u>0.5</u>	1.0	μ s					
BEARING	<u>TRUE</u>	MAG						

SELECT W/CROSS KEY (▲▼◀▶)
PRESS ENT TO SET
PRESS MUNU TO RETURN

RADAR SET-UP 2

Set the language of the letters on the display.

Selection may be from among the following.

English,	Japanese
Chinese,	French
Spanish,	Italian
Norwegian,	German
Korean	

RADAR SET-UP 2

LANGUAGE	ENGLISH	日本語
	中文	FRANCAIS
	ESPANYOL	ITALIANO
	NORSK	DEUTSCH
	한국어	

SELECT W/CROSS KEY (▲▼◀▶)
PRESS ENT TO SET
PRESS MUNU TO RETURN

INITIAL SETTING 1

This menu appears when the **MENU** key and **ENTER** key are pushed simultaneously.

Implement various adjustments on the receiver (including rough tuning adjustment)

Adjust the bearing of the image on the PPI screen.

Adjust the distance of the image on the PPI screen.

Adjust the strength of the main bang suppression.

Adjust the range of the main bang suppression.

Adjust the maximum sensitivity when the GAIN control is turned fully to the right (maximum sensitivity).
Normally, the maximum is set at 255.

Adjust the criterion level when the radar image signal is A/D.

Adjust the strength of the sea surface clutter suppression.

Select the height to the scanner unit as follows: 5m or less/ 5 to 10m/ 10m or more.
It optimizes the characteristics of the sea surface clutter suppression by this setting.

When connected to an external GPS, set the initial value of the GPS.

Display the menu "INITIAL SETTING 2".

Set the time differential receipt number.

Display the PPI screen for demonstration purposes.

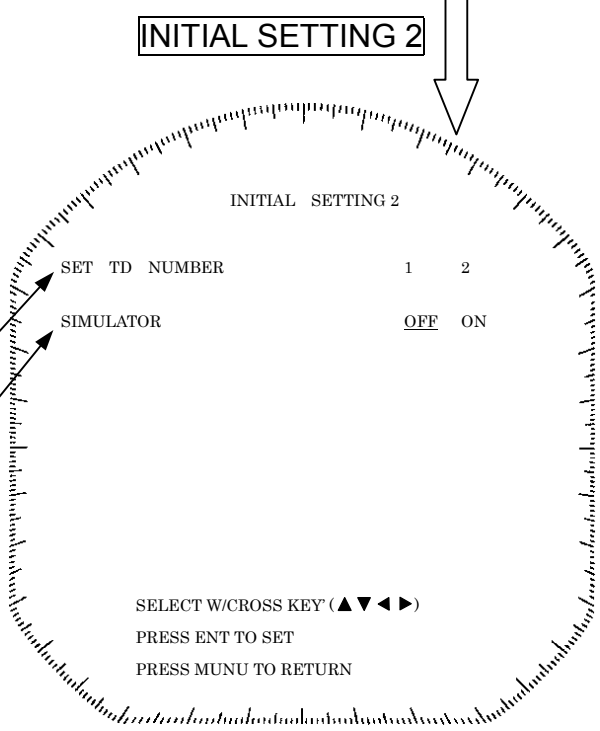
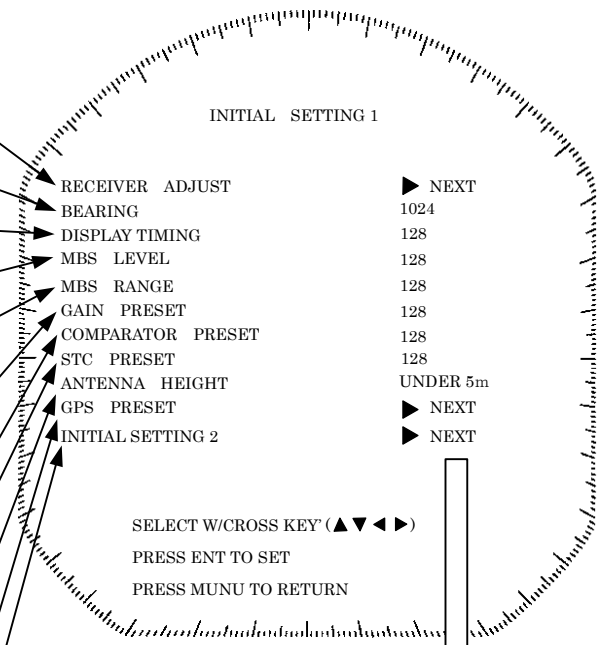

3 Basic Operations

3.1 *Flow of Operations*

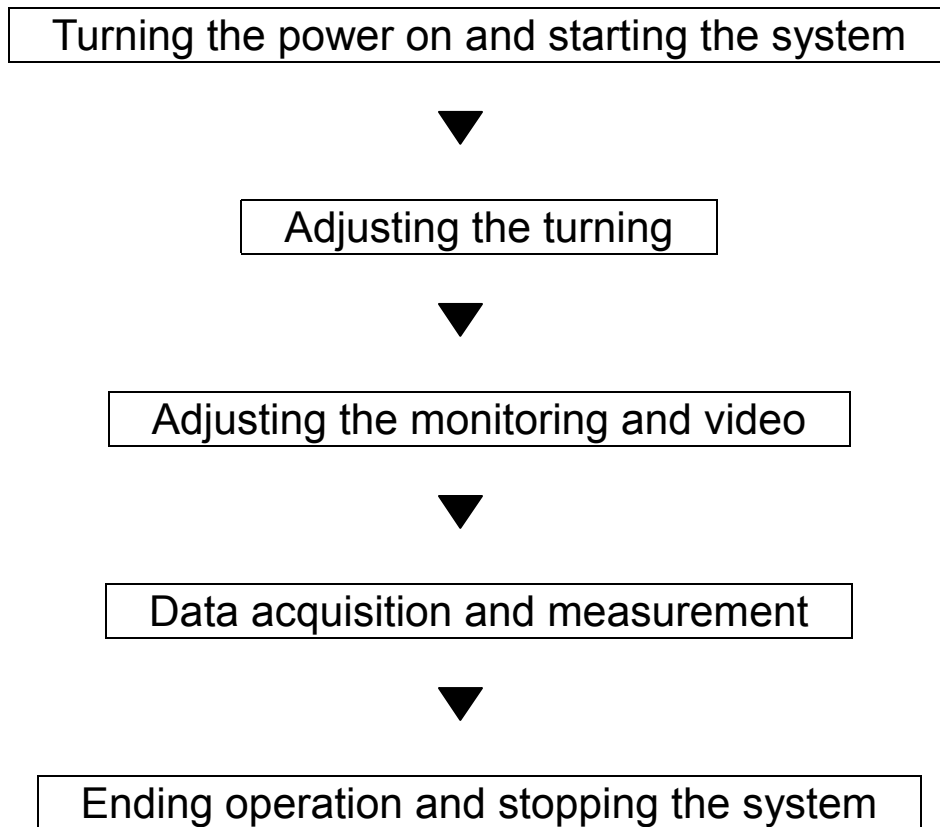

Basic operations are explained on the following pages

Soft key operation

The basic operations using the soft key are as follows.

From among the 4 switches that are positioned below the screen, push the switch that corresponds to the required function. The items are displayed at the lower part of the screen and the required setting may be undertaken by pushing the switch that corresponds to the desired items.

Push the **MENU** key to return to the lowermost tier item.

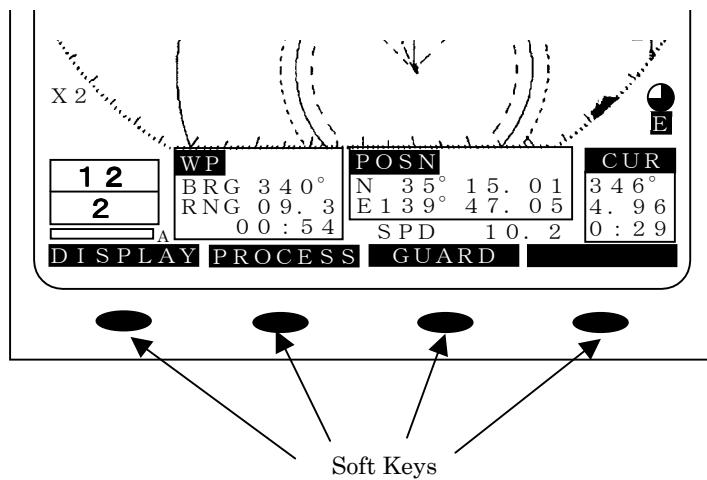

3.1.1 Turning the power ON and starting the system

1. Turning the power ON

In order to turn the power on, push the **STBY/OFF** key.

When the power is turned on, a count down timer is displayed on the screen and the system enters the standby state after 1 minute and 30 seconds.

Moreover, cumulative energized time and cumulative transmission time are also displayed. This is used as an indicator for when maintenance is required. Time displays may incorporate some small errors.

2. Undertake transmission

In order to transmit from the standby mode, push the **X-MIT/OFF** key.

When returning from the transmission mode to the standby mode, push the **STBY/OFF** key.

3.1.2 Tuning operation

The tuning operation of this radar equipment may be undertaken manually or automatically. Switching between manual operation and automatic operation is undertaken using the soft key. In the case of automatic tuning, the letter "A" will be displayed at the right of the lower left hand tune level indicator.

(a) Switching tuning modes

Push the soft key **PROCESS** .



Each time key 3 is pushed, the mode sequentially changes between **A-TUNE** and **M-TUNE** and if the manual mode is preferred, key 3 should be pushed so that **M-TUNE** is selected.

(b) Turn the [TUNE] control

In the case of manual tuning, rotate the [TUNE] control on the operation panel to maximize the size of the image. The tune level indicator acts as an indicator when undertaking manual tuning and should be adjusted so that the indicator is at the maximum position.

In the case of automatic tuning, there is no need to turn the [TUNE] control.

In the event no image appears, turn the [GAIN] control on the control panel all the way to the right and set [SEA] control and the [RAIN] control furthestmost to the left.

3.1.3 Adjusting monitoring and image

Display the optimal image by adjusting the [TUNE] control (in the case of manual tuning), [GAIN] control, [SEA] control and [RAIN] control on the control panel.

The range of monitoring distance may be switched by pushing the "▲ (up)" or "▼ (down)" of on **RANGE** key.

The distance range currently selected will be displayed at the lower left hand corner of the display (please refer to "2.2 Explanation of Screen Readout").

3.1.4 Data acquisition and monitoring

Please refer to "3.3 Basic Operations" and "4 How to Interpret the PPI Screen" for the various operations.

3.1.5 Ending the operation and shutting down the system

1. Interrupting the transmission

(a) Push the **STBY/OFF** key.

The transmission will be interrupted and the display will return to the standby mode.

2. Shutting the power off

(a) Push the **X-MIT** key and the **STBY/OFF** key simultaneously.

The radar will stop operation and all functions will shut down.

WARNING



When performing such work as maintenance, shut the power off and disconnect the power connector between the rectifier and the display to cease supply of electricity to the system.

Even if the power switch is off, electricity may be flowing internally in the various equipments and performing maintenance and repair under such conditions may cause accidents such as severe electric shock or equipment breakdown.

3.2 Monitoring Standby

3.2.1 Changing the brightness of the screen

- (a) Push the key.

Each time this key is pushed, the brightness of the screen increases by a step.

When the brightness is at the 8th step (maximum) and if the switch is again pushed, the brightness will be reduced by one step. When the power is turned on, the brightness level is set at "7".

3.2.2 Changing the brightness of the control panel lighting

- (a) Select levels "0" through "7" in the line "DIMMER" - the menu "RADAR SET-UP 1".

The higher the selected number, the brighter the lighting.

- (b) Push the key.

Menu setting has been completed.

3.2.3 Switching among display languages

The language display on the screen may be switched among English, Japanese and other languages (Chinese, French, Spanish, Italian, Norwegian, German and Korean).

- (a) Select the desired language in the line "LANGUAGE" - the menu "RADAR SET-UP 2".

- (b) Push the key.

The menu setting has been completed.

3.2.4 Setting the buzzer volume

- (a) Select levels "0" through "7" in the line "BUZZER" - the menu "RADAR SET-UP 1".

The higher the selected number, the louder the buzzer.

- (b) Push the key.

The menu setting has been completed.

3.3 Basic Operations

3.3.1 Transmitting

- (a) Push the **X-MIT/OFF** key.

The system will switch from standby mode to transmission mode.

3.3.2 Interrupting transmission

- (a) Push the **STBY/OFF** key.

The system will switch into standby mode and the legend "Standby" will appear on the screen.

3.3.3 Changing the range (scale of distance)

- (a) Push the **RANGE** key.

Pushing the "▲(up)" key increases the scale of distance.

Pushing the "▼(down)" key decreases the scale of distance.

3.3.4 Erasing and displaying the fixed range ring

- (a) Push the soft key **DISPLAY** .

- (b) Push the soft key 3 and when erasing the scale, select **RR OFF** and when displaying, select **RR ON** .

- (c) Push the **MENU** key.

The soft key menu will return to the initial function display.

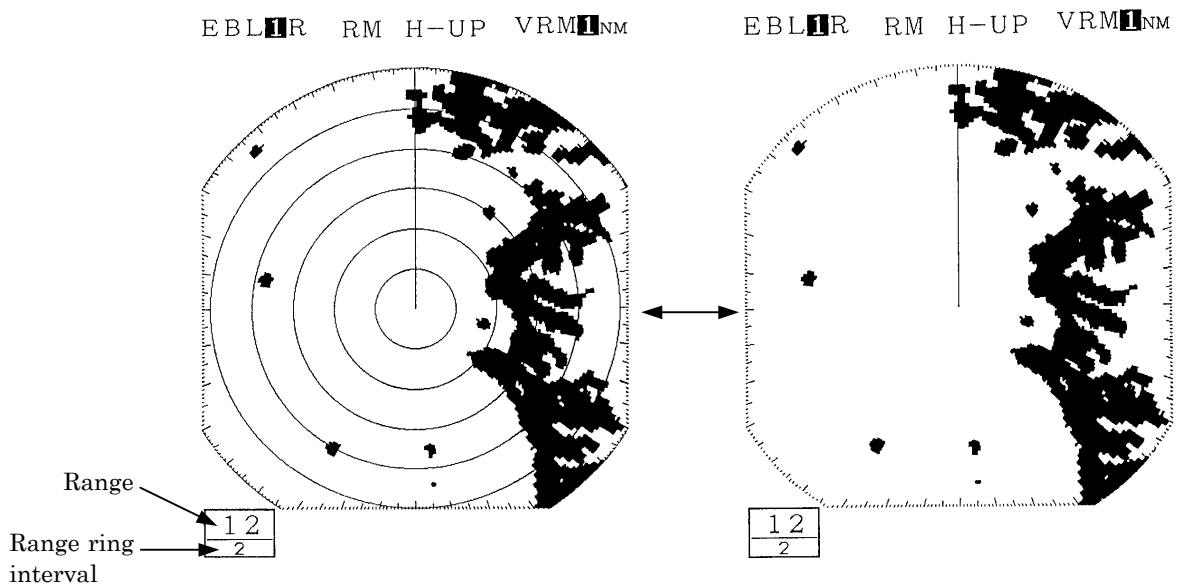

3.3.5 Erasing ship's heading marker

(a) Continue to push the

BRIL/HL OFF

 key for 2 seconds or more.

The ship's heading marker shows the heading of the ship.

While the

BRIL/HL OFF

 key is being pushed, the ship's heading marker will disappear and will again be displayed when the key is released.

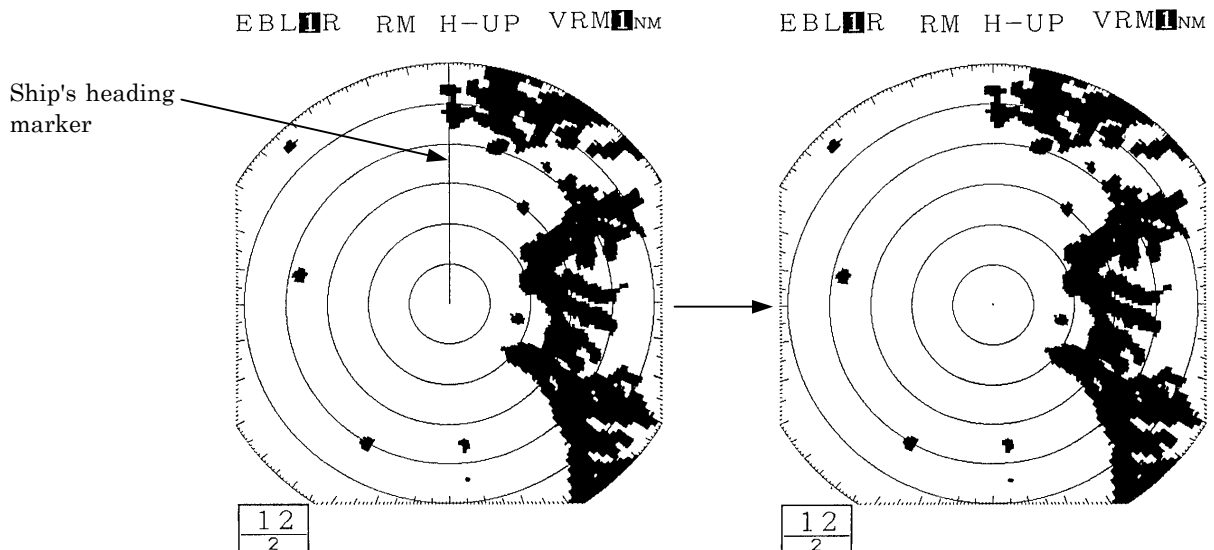

3.3.6 Adjusting the tuning

Please refer to "3.1.2 Tuning operation".

3.3.7 Adjusting the sensitivity

Attention

- Please ensure that the sensitivity adjustment is made to an optimal level when undertaking monitoring.
- If the sensitivity is too low, hazardous objects, ships and other floating objects may not be displayed.
- If the sensitivity is too high, receiver noise at the PPI screen will increase and this may impair monitoring.

(a) Turn the [Gain] control.

- When the control is turned in the counterclockwise direction, the sensitivity decreases and when the control is turned in the clockwise direction, the sensitivity increases.
- In general, optimal adjustment of sensitivity is as follows.

The image size of the echo from the intended target is maximized.

It does not come into contact with echoes from other targets.

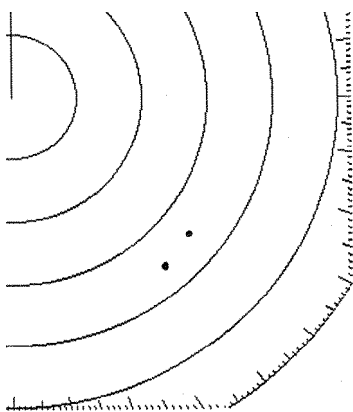

The image of the echo is small as the sensitivity is too low.

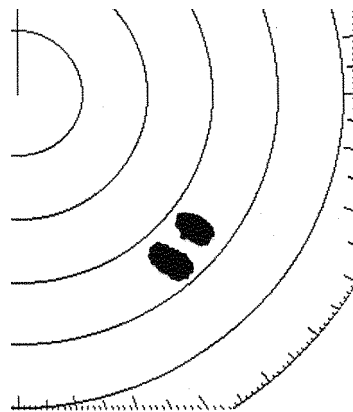

The sensitivity has been adjusted to an optimal level.

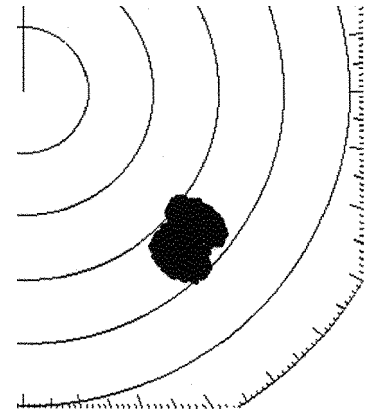

Images overlap as the sensitivity is too high.

3.3.8 Eradicating radar interference

Attention

- Weak echo images from hazardous objects such as other vessels may also be rejected when using the interference rejection function.
- When observing radar beacons or SART signals, make sure that the interference rejection function is disabled.

Radar interference refers to the phenomenon by which microwaves transmitted by a third party radar is picked up directly by the ship's scanner unit and is displayed on the PPI screen.

(a) Push the soft key **PROCESS** .

(b) Push soft key 2 to select **IR 1** .

(c) If radar interference cannot be rejected using **IR 1** , push soft key 2 and select **IR 2** .

When not undertaking interference rejection, push soft key 2 and select **IR OFF** .

(d) Push the **MENU** key.

The soft key menu will return to the initial function display.

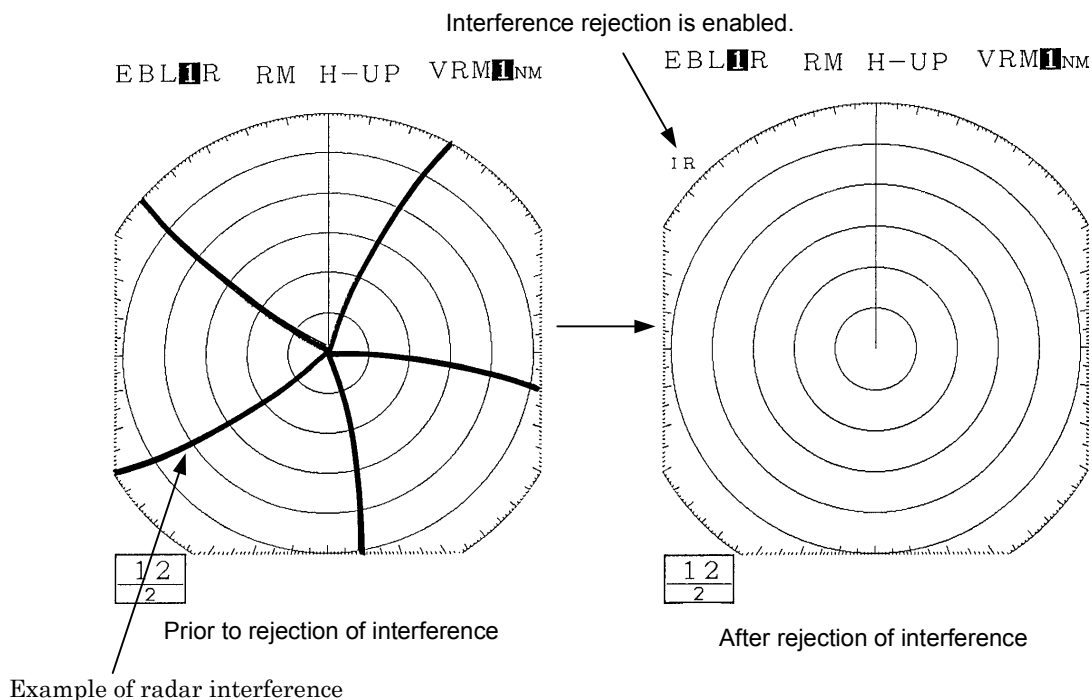

3.3.9 In the event of rain or snow

CAUTION



Refrain from setting the rain and snow clutter suppression function needlessly. Doing so may suppress echoes from targets such as other vessels for hazardous objects in addition to echoes from rain and snow thus impairing detection. When using the rain and snow clutter suppression function, ensure that the suppression setting is always at an optimal level.

When rain or snow falls, echo from the rain or snow (rain clutter) appears on the PPI screen making it difficult to see images of echoes from vessels or other objects.

By using the [RAIN] control function or the "automatic rain and snow" function, rain clutter may be suppressed facilitating monitoring of the target.

When the "automatic rain and snow" function is operating, it is not possible to use the [RAIN] control function.

Manual rain and snow clutter suppression

- (a) Turn the [RAIN] control.

As the control is turned to in the clockwise direction, the rain and snow clutter suppression function becomes stronger.

Automatic rain and snow clutter suppression

- (a) Push the soft key PROCESS .

- (b) Push the soft key 1 and select A-RAIN .

Rain and snow clutter suppression is enabled depending on the condition of the image.

- (c) Push the MENU key.

The soft key menu will return to the initial function display.

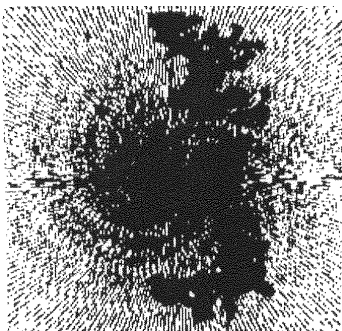

Rain clutter is being shown as an image

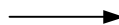

Rain clutter has been suppressed (the image of the echo from the target is also suppressed).