



User Guide

2600 / 2610 Matrix Printer



Important Safety Instructions (English)

Read the following instructions thoroughly before starting up your printer.

- Never carry out maintenance or repair work yourself. Always contact a qualified service technician.
- Keep this Operator's Manual in a place which is easily accessible at all times.
- Place the printer on a solid and even base so that it cannot fall.
- Never place the printer in the vicinity of inflammable gas or explosive substances.
- Ensure the printer is connected to a socket with the correct mains voltage.
- Always disconnect the printer from the mains before opening the device to perform maintenance work or remedy errors.
- Do not expose the printer to high temperatures, direct sunlight or dust.
- Keep all liquids away from the printer.
- Protect the printer from shock, impact and vibration.

Make sure that the printer and computer are switched off before connecting the data cable.

- The print head will become very hot during printing; avoid contact with the print head after printing has finished.
- Do not perform any operation or action in any way other than those provided in this manual. When in doubt, contact your dealer or your customer support.

Wichtige Sicherheitshinweise (German)

Lesen Sie bitte diese Sicherheitshinweise durch, bevor sie den Drucker in Betrieb nehmen.

- Führen Sie Wartungsarbeiten und Reparaturen keinesfalls selbst aus, sondern verständigen Sie immer einen qualifizierten Servicetechniker.
- Bewahren Sie diese Dokumentation an einem jederzeit zugänglichen Ort auf.
- Den Drucker auf stabilem und ebenem Untergrund so aufstellen, dass er nicht zu Boden fallen kann.
- Stellen Sie den Drucker keinesfalls in der Nähe von leicht entzündlichen Gasen oder explosiven Stoffen auf.
- Den Drucker nur an eine Steckdose mit der richtigen Spannung anschließen.
- Wenn Sie den Drucker vom Netz trennen wollen, den Drucker ausschalten und immer den Netzstecker an der Steckdose ziehen.
- Den Drucker weder hohen Temperaturen noch direktem Sonnenlicht und Staub aussetzen.
- Keine Flüssigkeiten mit dem Drucker in Berührung bringen.
- Den Drucker keinen Erschütterungen, Stößen oder Vibrationen aussetzen.
- Sicherstellen, dass der Drucker und der Computer ausgeschaltet sind, bevor das Datenkabel angeschlossen wird.
- Der Druckkopf wird während des Druckens heiß. Vor dem Berühren deshalb einige Zeit abkühlen lassen.
- Weichen Sie bei der Bedienung des Druckers nicht von den Anweisungen in der Dokumentation ab.
Bei Unklarheiten wenden Sie sich bitte an Ihren Händler oder Ihren Kundendienst.
- Maschinenlärm informations – Verordnung – 3.GPSGV, der höchste Schalldruckpegel beträgt 70 dB(A) oder weniger gemäß EN ISO 7779.

Consignes importantes de sécurité (French)

Lire attentivement les instructions suivantes avant de mettre l'imprimante en service.

- Ne jamais effectuer soi-même les travaux d'entretien et de réparations. Contacter toujours un dépanneur qualifié.
- Placer l'imprimante sur un support stable de façon à ce qu'elle ne puisse pas tomber.
- Ne jamais placer l'imprimante à proximité de sources de gaz aisément inflammables ou de substances explosives.
- Ne connecter l'imprimante à une prise que lorsque la tension est correcte.
- Pour déconnecter l'imprimante de l'alimentation principale, mettre l'imprimante hors tension et toujours débrancher le connecteur secteur de la prise murale.
- Ne pas exposer l'imprimante à des températures élevées, à la lumière directe du soleil ou à la poussière.
- Ne pas mettre l'imprimante en contact avec des liquides.
- Ne pas exposer l'imprimante à des chocs, impacts ou vibrations.
- S'assurer que l'imprimante et l'ordinateur sont hors tension avant de connecter le câble de données.
- La tête d'impression est brûlante pendant l'impression. C'est pourquoi laissez-la refroidir quelques instants avant d'y toucher.
- N'exécutez aucune opération ni action d'une autre manière que celle indiquée dans ce manuel. En cas de doute, veuillez contacter votre distributeur ou service après-vente.

Indicazioni di sicurezza importanti (Italian)

Prima di mettere in funzione la stampante, leggere attentamente le seguenti indicazioni.

Non eseguire mai da sé gli interventi di manutenzione e riparazione, ma rivolgersi sempre a un tecnico di assistenza qualificato.

- Conservare le presenti istruzioni per l'uso in un luogo sempre accessibile.
- Collocare la stampante su una superficie stabile, per evitare che cada a terra.
- Non collocare la stampante in prossimità di gas facilmente infiammabili o di sostanze esplosive.
- Collegare la stampante a una presa di corrente con tensione adeguata.
- Per scollegare la stampante dalla rete di alimentazione, spegnere la stampante e disinserire sempre il connettore di rete dalla presa.
- Non esporre la stampante ad elevate temperature né alla luce solare diretta e alla polvere.
- Evitare il contatto della stampante con liquidi.
- Non esporre la stampante a colpi, scosse o vibrazioni.
- Verificare che la stampante e il computer siano spenti prima di collegare il cavo di trasmissione dati.
- Durante la stampa, la testina si surriscalda notevolmente. Prima di toccarla, se necessario opportuno quindi lasciarla raffreddare qualche istante.
- Non eseguire alcuna operazione o azione se non nella maniera descritta nel presente manuale. In caso di dubbio, contattare il rivenditore o dalla società incaricata dell'assistenza.

Instrucciones de seguridad importantes (Spanish)

Lea las siguientes instrucciones con esmero antes de poner la impresora en servicio.

Nunca lleve a cabo trabajos de mantenimiento o reparación Ud. mismo, sino consulte a un técnico de servicio calificado.

- Guarde las presentes instrucciones de servicio en un lugar de fácil acceso en cualquier momento.
- Ponga la impresora sobre un base estable de manera que no pueda caer al suelo.
- Nunca coloque la impresora en la vecindad de gases de fácil inflamabilidad o sustancias explosivas.
- Asegure conectar la impresora sólo a un enchufe con un voltaje correcto.
- Cuando quiera desconectar la impresora de la red, apague la impresora y siempre tire la clavija de alimentación del enchufe.
- No exponga la impresora a temperaturas altas, a la luz solar directa y al polvo.
- No ponga la impresora en contacto con fluidos.
- Nunca exponga la impresora a sacudidas, choques o vibraciones.
- Asegúrese de que la impresora y el ordenador estén apagados antes de conectar el cable de datos.
- La cabeza de impresión se pone muy caliente durante la impresión. Por lo tanto, deje enfriarlo algún tiempo antes de tocarla.
- No permita que se realice cualquier operación o acción de una forma diferente a lo que se señala en el manual. En caso de duda, póngase en contacto con su comerciante o con su servicio post-venta.

Правила по технике безопасности. (Russian)

Прочитайте, пожалуйста, инструкцию по технике безопасности перед включением в работу принтера.

- Не выполняйте технические работы и ремонт техники самостоятельно, но сообщайте о неисправностях квалифицированным сервисным техникам.
- Данная инструкция должна быть всегда доступна каждому пользователю.
- Установите принтер на ровном и стабильном месте так, чтобы он не смог упасть на пол.
- Ни в коем случае не ставьте принтер вблизи легко воспламеняющихся газов и взрывчатых веществ.
- Включайте принтер в розетку только с соответствующим напряжением.
- Если Вы хотите отключить принтер от напряжения, сначала выключите принтер сам и затем выньте штекер из розетки.
- Берегите принтер от нагревания, от попадания на него прямых солнечных лучей и пыли.
- Не допускайте попадания жидкости на принтер.
- Нельзя подвергать принтер тряске, ударам и вибрации.
- Убедитесь, что принтер и компьютер выключены, только после этого соедините принтер с компьютером.
- Печатающая головка нагревается во время работы принтера. Поэтому подождите какое-то время, прежде чем дотронуться до нее.
- Пользуйтесь принтером так, как это написано в документации. Если у Вас возникают неясности, обращайтесь с вопросами к Вашим продавцам или в сервисный центр.

Instruções Importantes sobre Segurança (Portuguese)

Leia as instruções de segurança antes de usar a impressora.

- Consulte sempre um técnico qualificado para executar uma reparação .
- Coloque a impressora sobre uma base sólida e nivelada, para que ela não sofra quedas.
- Jamais instale a impressora nas proximidades de lugares onde haja gás inflamável ou substâncias explosivas.
- Assegure-se de conectar a impressora à tomada elétrica com a voltagem apropriada.
- Quando desligar a impressora da rede, desligue sempre a impressora e retire o cabo da tomada.
- Não exponha a impressora a temperaturas altas ou luz solar direta.
- Não aproxime substâncias líquidas da impressora.
- Proteja a impressora de choques, impactos e vibrações.
- Desligue a impressora e o computador antes de conectar o cabo da rede.
- A cabeça da impressora pode ficar muito quente . Portanto, espere algum tempo antes de tocá-la.
- Não faça nenhuma operação ou ação além das recomendadas neste manual. Em caso de dúvida, contate seu revendedor ou companhia de serviço.

Önemli Güvenlik Talimatları (Turkish)

Lütfen, yazıcıyı işleme geçirmeden önce bu güvenlik talimatlarını bütünüyle dikkatle okuyun.

- Bakım ve tamir çalışmalarını kesinlikle ve hiçbir surette kendi başınıza yapmayın; her zaman kalifiye bir uzman servis-teknişyenine haber verin.
- Yazıcıyı, üzerinden yere düşmesim mümkün olmayacak sabit ve düz bir zemine yerleştirin.
- Yazıcıyı kesinlikle ve hiçbir surette kolayca yanabilecek gaz veya patlayıcı maddeler içeren nesnelere yakınına koymayın.
- Yazıcı kablolarını sadece doğru gerilime sahip bir prize takın.
- Yazıcıyı şebeke ağından ayırmak istediğinizde, yazıcıyı kapatın ve ağ-fişini her zaman prizden çıkartın.
- Yazıcıyı ne yüksek ısı ne de doğrudan güneş ışığına ve toza mâruz kalan mekânlarda bulundurun.
- Yazıcı hiçbir sıvı maddeyle temasta olmamalıdır.
- Yazıcı hiçbir sarsıntıya, darbeye veya titreşime mâruz kalmamalıdır.
- Veri kablosu bağlanmadan önce hem yazıcının hem de bilgisayarın kapalı olduklarından emin olmalısınız.
- Yazıcının başı basma esnasında yüksek ısıya ulaşır. Bu yüzden lütfen dokunmadan önce kısa süre soğumasını bekleyin.
- Yazıcının işletimi ve kullanımında bu dokümantasyondaki talimatların hiç dışına çıkmayın. Sorunlu görülen hususlarda lütfen imalatçınıza veya müşteri hizmetleri servisimize başvurun.

TRADEMARK ACKNOWLEDGEMENTS

“IBM” is a trademark of International Business Machines Corporation.

“EPSON” is a trademark of Epson America Incorporated.

“DEC” is a trademark of Digital Equipment Corporation.

“Centronics” is a trademark of Centronics Data Computer Corporation.

“DOS” is a trademark of Microsoft Corporation.

“SAP” is a trademark of SAP AG.

“Windows”, “Windows 7”, “Windows 8”, “Windows 95”, “Windows 98”, “Windows NT”, “Windows 2000”, “Windows 2003/2008/2013 Server”, “Windows XP” and “Windows Vista” are trademarks of Microsoft Corporation.

All other product names and company names appearing in this manual are the registered trademarks or trademarks of the individual companies.

TABLE OF CONTENTS

1	Printer at a glance	1
1.1	Unpacking the printer	1
1.2	Unpacking the Printer	2
1.3	Parts description	4
2	Installation	5
2.1	Placing the printer	5
2.2	Connecting the printer	5
2.2.1	Parallel interface (IEEE 1284)	6
2.2.2	USB 2.0 (Full Speed)	6
2.2.3	Ethernet	6
2.2.4	Serial Interface (RS-232C) as option	7
2.2.5	Connecting the power	7
2.2.6	Switch on the printer	7
2.3	Installing the ribbon cartridge	8
3	Installing the paper	10
3.1	Adjusting the print gap for various form thicknesses	10
3.2	Paper path introduction	11
3.2.1	Cut sheet paper handling (front friction only)	11
3.2.2	Fanfold paper handling	12
3.2.3	Top-Of-Form adjustment	16
4	Control Panel Operation	17
4.1	Operation of the LED Panel	17
4.1.1	Keys and Indicators	17
4.1.2	Online Operations	19
4.1.3	Offline Operations	20
4.1.4	Power-On Operations	22
4.2	Operation of the LCD Panel	23
4.2.1	The LC display	23
4.2.2	Online mode	24
4.2.3	Offline mode	24
4.2.4	Setup mode	25
4.2.5	Power on functions	25
5	Setting parameters for the printer	26
5.1	Setting the parameters through the LED Panel	26
5.1.1	Fine tuning the TOF and Tear positions	26
5.1.2	Select a font	27
5.1.3	Settings within Menu	28
5.2	Setting the parameters through the LCD Panel	29
5.2.1	Enabling access to menu mode	29
5.2.3	Menu configurations	30
5.2.4	Menu handling	32
5.2.5	Selecting the LC display language	33
5.3	Menu structure	34
5.4	Full list parameters setting	35
5.4.1	Menu Configuration list	35
5.4.2	Advanced Menu	42
5.5	Display messages	44
5.5.1	Messages LED Panel	44
5.5.2	Messages LCD Panel	45
6	Web Panel and Internal Ethernet Interface	46
6.1	Summary	46
6.1.1	Introduction	46
6.1.2	Supported Environments	46
6.1.3	Network Interface and Cabling	46
6.1.4	Connecting the Printer	46
6.1.5	Network Interface Status	46

Tally Dascom 2610

6.2	IP Configuration.....	47
6.2.1	Network IP Configuration.....	47
6.2.2	Assigning the IP Address.....	47
6.3	WebPanel.....	49
6.3.1	Introduction.....	49
6.3.2	Web Browser.....	49
6.3.3	Access to WebPanel.....	50
6.3.4	Printer Status.....	50
6.3.5	Printer Configuration.....	51
6.3.6	Printer Actions.....	54
6.3.7	Load Configuration.....	55
6.3.8	Save Configuration.....	56
6.3.9	Retrieve Configuration From Printer.....	56
6.3.10	Send Configuration to Printer.....	57
6.3.11	Report.....	59
6.3.12	Reset Printer.....	59
6.3.13	Panel Lock On/Off.....	59
6.3.14	Download Firmware.....	59
6.3.15	TallyCom Status.....	62
6.3.16	Advanced Configuration.....	63
6.3.17	General.....	64
6.3.18	TCP/IP.....	65
6.3.19	SNMP.....	66
6.3.20	Password.....	67
6.3.21	User Name.....	67
6.3.22	Resetting Password.....	67
6.3.23	Email Notification.....	68
6.3.24	Logical Printers.....	70
6.3.25	String Replacement Example Plain Text.....	71
6.3.25	Logout of TallyCom.....	72
6.3.26	Restart TallyCom.....	72
6.3.27	Virtual Control Panel.....	73
7	Addendum.....	74
7.1	Character Set.....	74
7.2	Control Codes Summary.....	79
7.2.1	PJL commands.....	88
7.2.2	Barcode.....	88
7.2.3	List of available MTPL barcodes.....	89
7.2.4	US Postnet barcode.....	89
7.2.5	Royal Mail Customer barcode.....	90
7.2.6	KIX barcode.....	90
7.2.7	USPS Intelligent Mail barcode.....	90
7.2.8	LC printing.....	91
7.2.9	List of additional control Codes.....	92
7.3	Interfaces Specifications.....	93
7.3.1	Parallel I/O IEEE 1284.....	94
7.3.2	Ethernet I/O 10/100 Multitprotocol.....	95
7.3.3	USB 2.0 I/O – Full Speed.....	96
7.3.4	Optional Serial Interface RS232C.....	97
8	Options and accessories.....	102
8.1	Options.....	102
8.2	Consumables.....	103
8.3	Accessories.....	103
9	General Specifications.....	104
9.1	Printer Specifications.....	104
9.2	Non-Scalable Fonts, Code Pages and National Character Sets.....	108
9.3	Paper Specifications.....	110
9.3.1	Standard Tractor (Front, Rear and Pull position) – narrow and wide versions.....	110

9.3.2	Front Feed / Manual Insertion – Narrow and wide versions	111
10	Maintenance	112
10.1	Cleaning	112
10.1.1	Cleaning and Vacuuming the Printer.....	112
10.1.2	Cleaning the Paper Rollers.....	112
10.2	Troubleshooting.....	113
10.2.1	Print Quality Problems and Solutions	113
10.2.2	Paper Handling Problems and Solutions.....	114
10.2.3	Operating Problems and Solutions.....	114
	DASCOM REPRESENTATIVES	115

Symbols used



Important information is highlighted in this manual by two symbols.

CAUTION highlights information which must be observed in order to prevent injuries to user and damage to the printer.



NOTE highlights general or additional information about a specific topic.



Changes or modifications not expressly approved by the responsible for compliance could void the user's authority to operate the equipment.

NOTE: This equipment has been tested and found to comply with the limits for a class B digital device, pursuant to Part 15 of the FCC Rules. These limits are designed to provide reasonable against harmful interference in a residential installation. This equipment generates, uses and can radiate radio frequency energy and, if not installed and used in accordance with the instructions, may cause harmful interference to radio communications. However, there is no guarantee that interference will not occur in a particular installation. If this equipment does cause harmful interference to radio or television reception, which can be determined by turning the equipment off and on, the user is encouraged to try to correct the interference by one or more of the following measures:

- Reorient or relocate the receiving antenna.
- Increase the separation between the equipment and receiver.
- Connect the equipment into an outlet on a circuit different from that to which the receiver is connected.
- Consult the dealer or an experienced radio/TV technician for help.

1 Printer at a glance

1.1 Unpacking the printer

Besides this manual, the package will contain: a power cord, a ribbon cartridge, a tractor, a CD and 6 pieces of U-wire paper support.

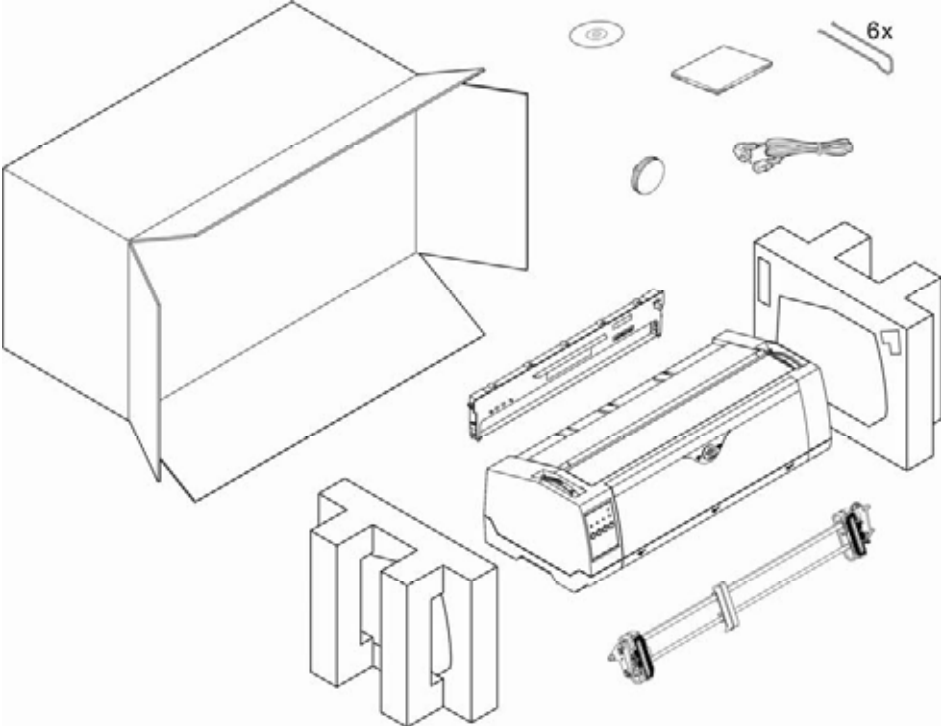

Prepare for your printer

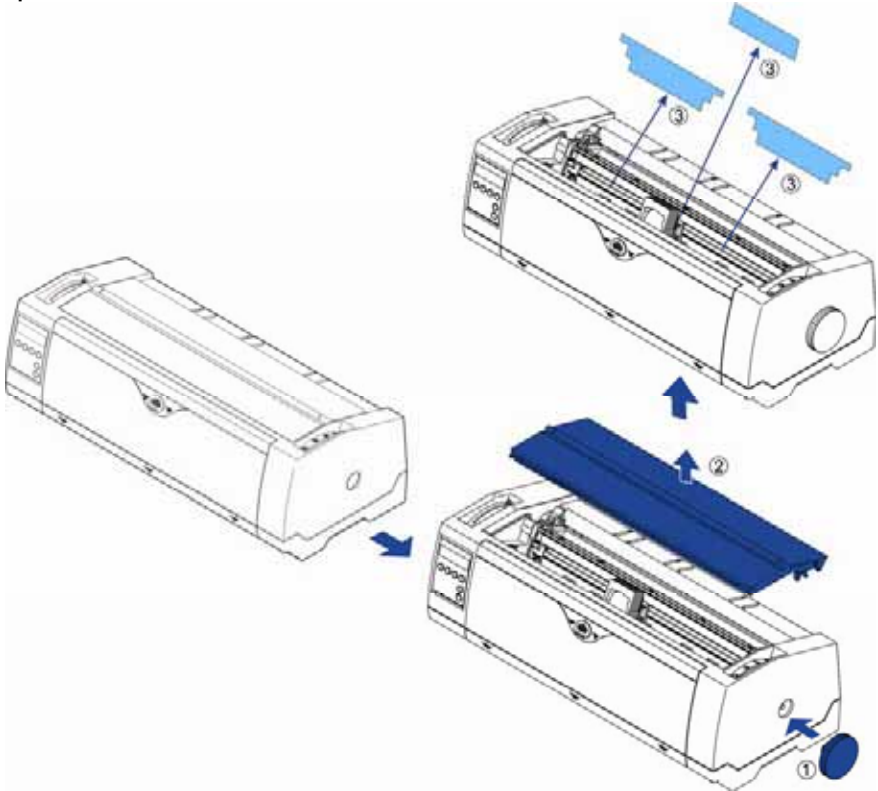

1.2 Unpacking the Printer

■ Front View

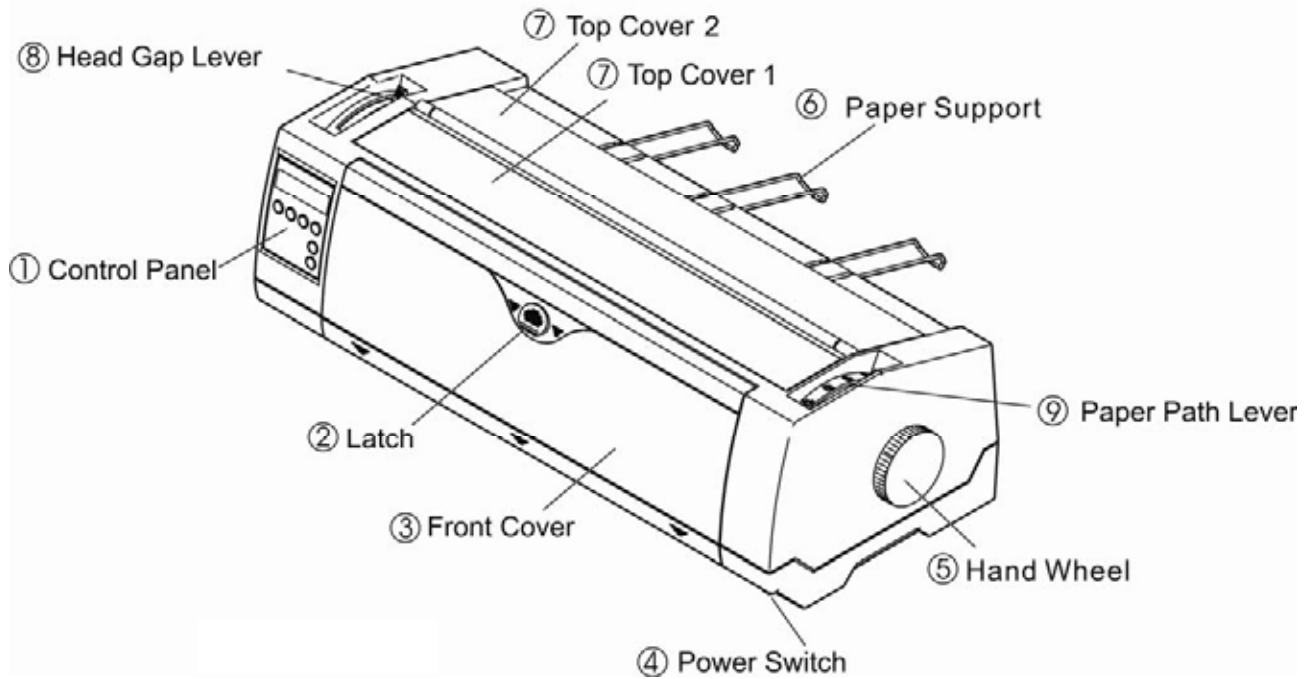

■ Rear View

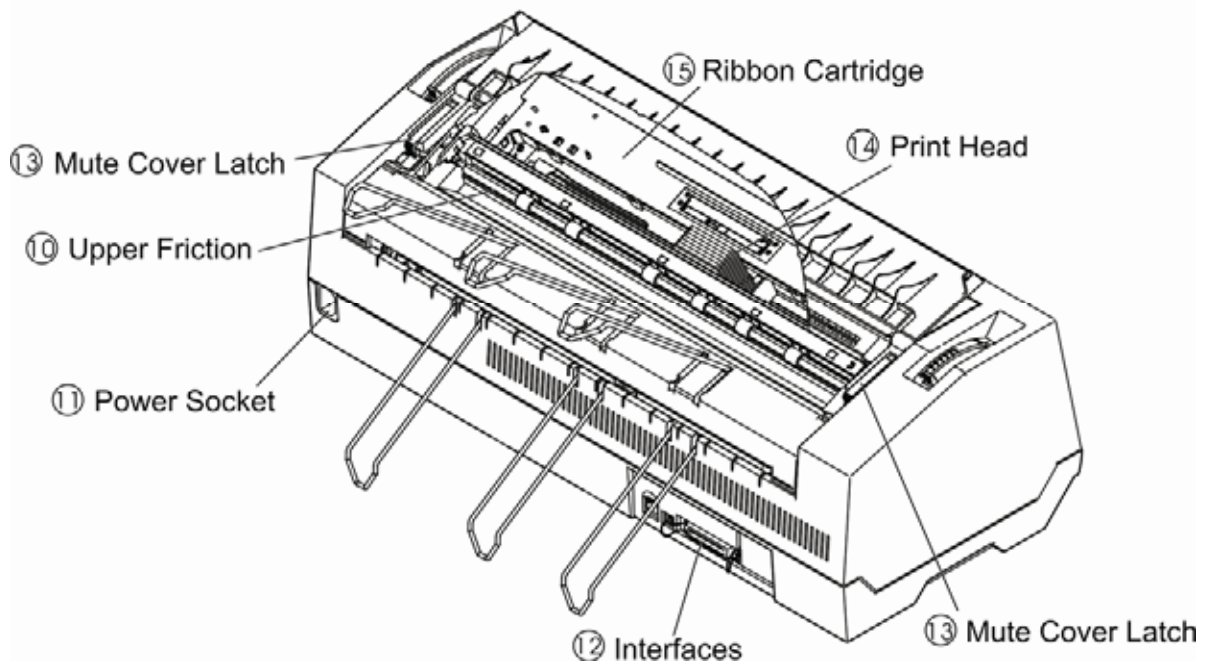

■ For Fanfold

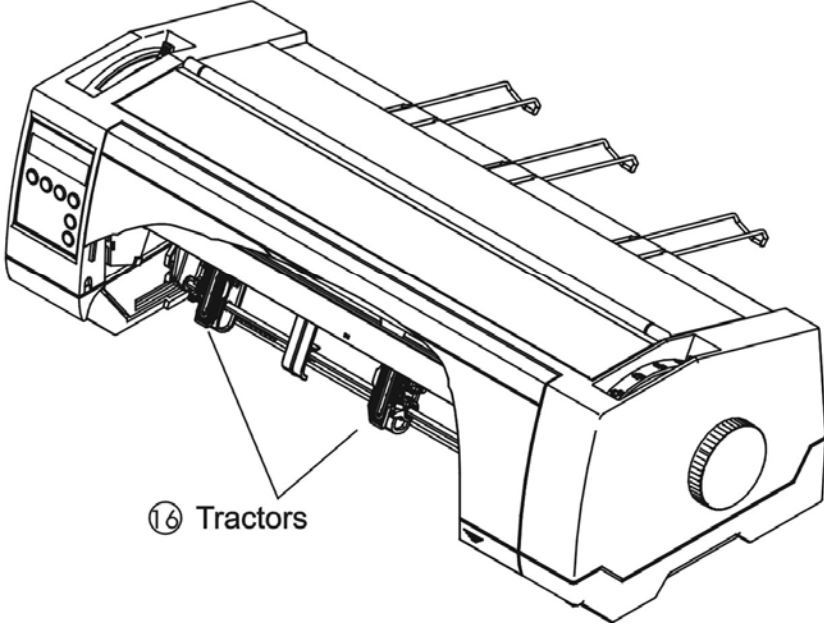

■ For Cut Sheets

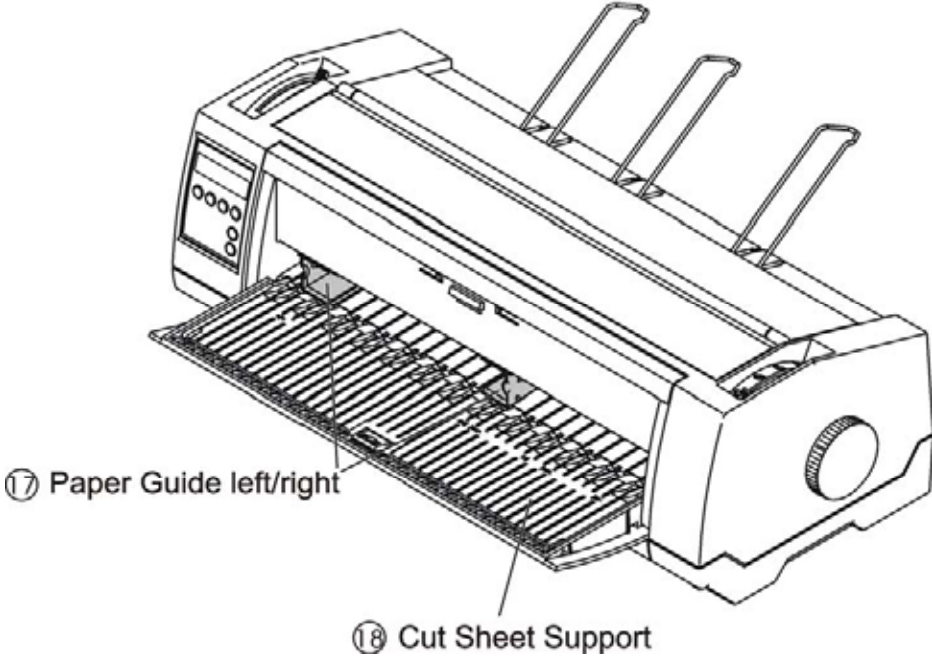

1.3 Parts description

1	Control Panel	LED: The 2-line LED with 4 keys panel indicates the operating status and allows simple settings of the printer; LCD: A LCD display and two keys indicates the operating status and allows simple settings of the printer.
2	Latch	Sliding it down unfolds the cut sheet support.
3	Front Cover	Unlocking the front cover unfolds the cut sheets support.
4	Power Switch	Turns on and off the printer.
5	Hand Wheel	Turn the knob to load or clear the paper. It should be inserted the full way until you can hear some sort of "Click".
6	Paper Support	At slanted position, it stacks cut sheets; at flat position, it separates fanfold printouts from incoming forms.
7	Top Covers 1&2	Protect the internal parts and reduce the noise.
8	Head Gap Lever	Adjusts the gap between the print head and various form thickness.
9	Paper Path Lever	Selects various paper sources.
10	Upper Friction	Guides the form when cut sheets or fanfold forms are used.
11	Power Socket	A power cord is plugged into the socket to supply the power.
12	Interfaces	The interface cable of the host computer is plugged into one of the interfaces.
13	Mute Cover Latch	You must open it before you open the top cover 1.
14	Print Head	Utilizes 24 needles to strike on ink ribbon and paper.
15	Ribbon Cartridge	Holds the ink ribbon fabric.
16	Tractors	Holds and transports fanfold forms.
17	Paper Guides Left/Right	Sliding the guides varies the form width and the left margin on a cut sheet.
18	Cut Sheet Support	A flat surface supports a sheet or multi-part form.

2 Installation

2.1 Placing the printer

Place the printer on a solid, flat, stable surface such that the printer sits firmly and cannot move. Select an environment with sufficient ventilation, easy access to the control panel and paper input areas as well as the printed output.

When selecting the printer location, observe the following additional requirements:

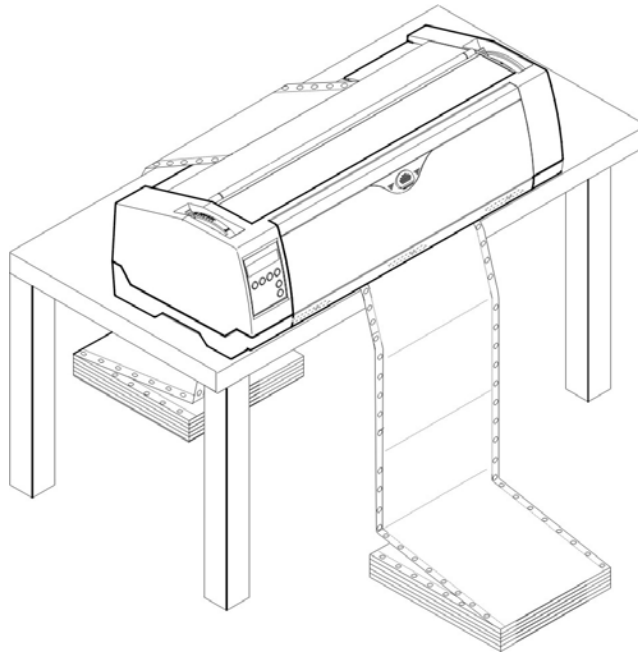

- 1) **Never place the printer near to any flammable gas or explosive substances.**
- 2) **Do not expose the printer to direct sunlight. If you cannot avoid placing the printer near a window, protect it from the sunlight with a curtain.**
- 3) **When connecting a computer to the printer, make sure the maximum recommended cable length is not exceeded.**
- 4) **Ensure sufficient distance between the printer and any heating devices/radiators.**
- 5) **Avoid exposing the printer to extreme temperature or air humidity fluctuations. Above all, avoid dusty environments.**

2.2 Connecting the printer

This printer is configured with a Parallel, USB and Ethernet interface as standard. An optional Serial interface can be installed additionally.

Tally Dascom 2610

2.2.1 Parallel interface (IEEE 1284)

Make sure that the printer and the computer are switched off and connect the parallel cable between the printer and the computer. Lock the connector with the 2 clips on the printer interface connector; tighten up the 2 screws on the other end connecting to the computer.

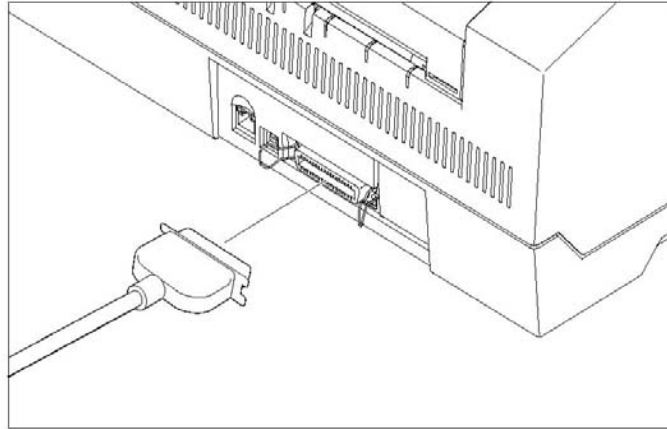

2.2.2 USB 2.0 (Full Speed)

Plug in the USB cable to the printer and the computer.

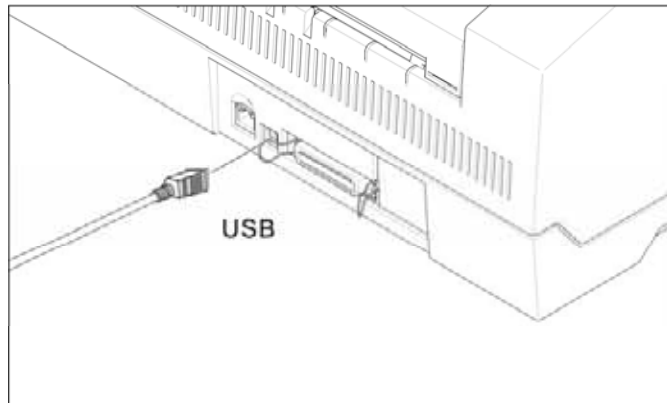

2.2.3 Ethernet

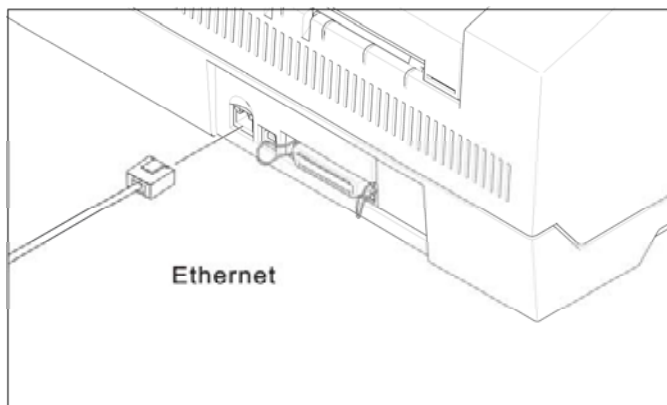

2.2.4 Serial Interface (RS-232C) as option

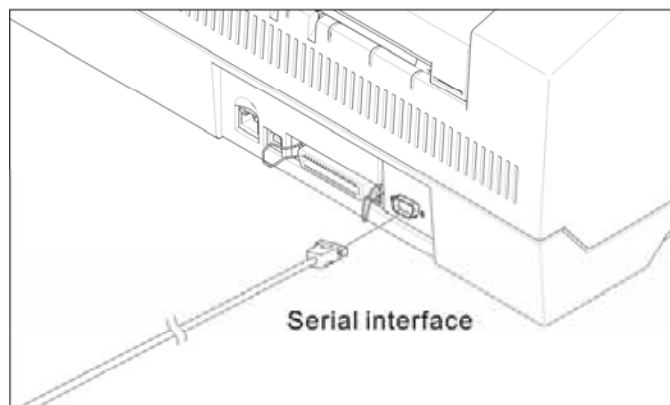

2.2.5 Connecting the power

Plug in the power cord to the printer power socket as shown in the diagram.

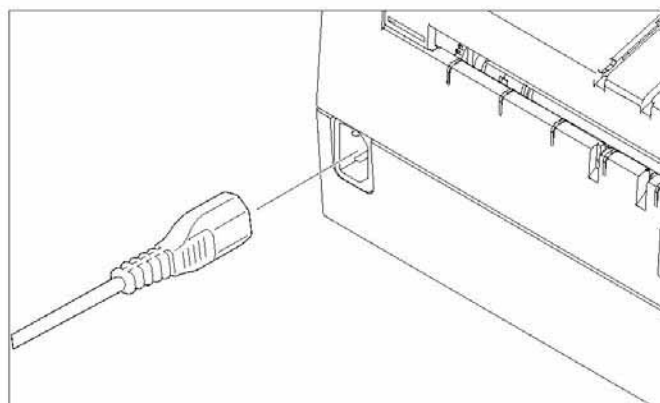

Connect the printer to the correct voltage power source.

2.2.6 Switch on the printer

Switch on the printer as shown in the diagram.

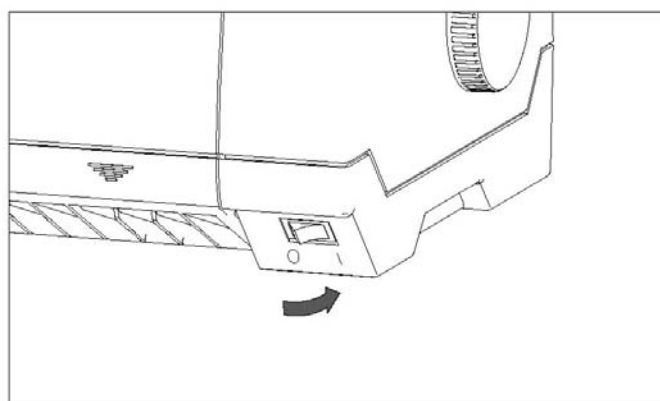

2.3 Installing the ribbon cartridge

- 1) Switch off the power.
- 2) Unfold the top cover and follow the steps 1.2.3.4 in the below picture.

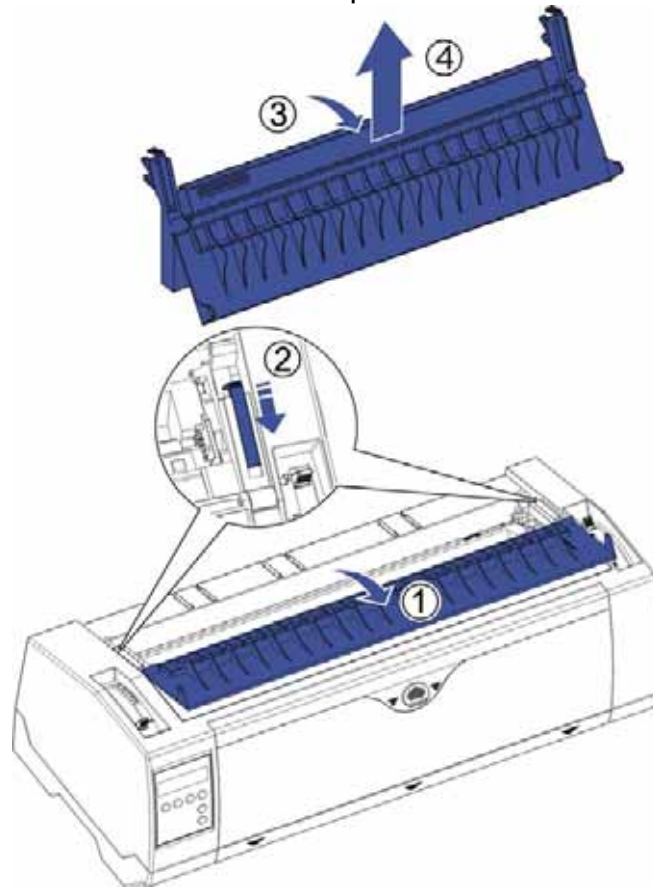

- 3) Flip the upper friction assembly

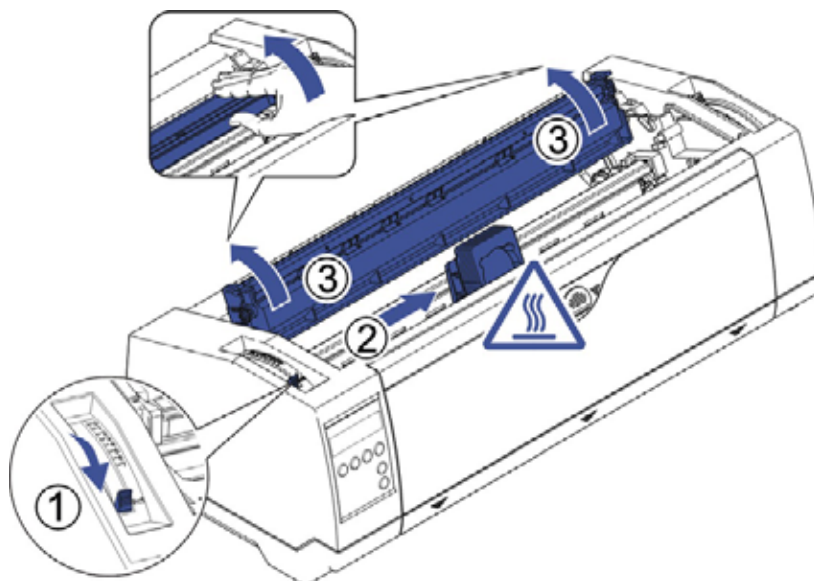

4) Insert the ribbon cartridge till it is tightly locked in position.

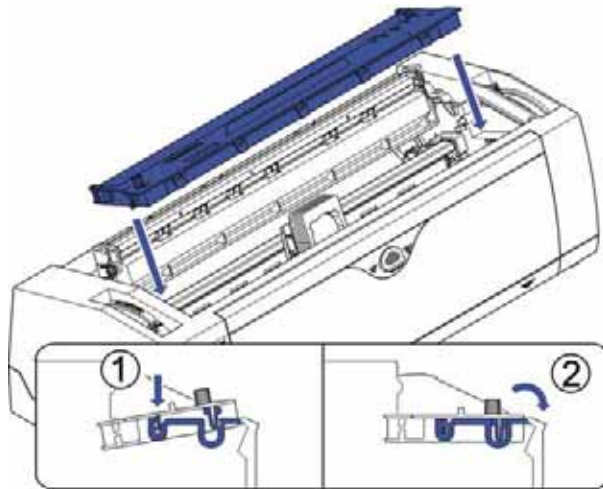

5) Insert the ribbon fabric in between the print head and ribbon mask.

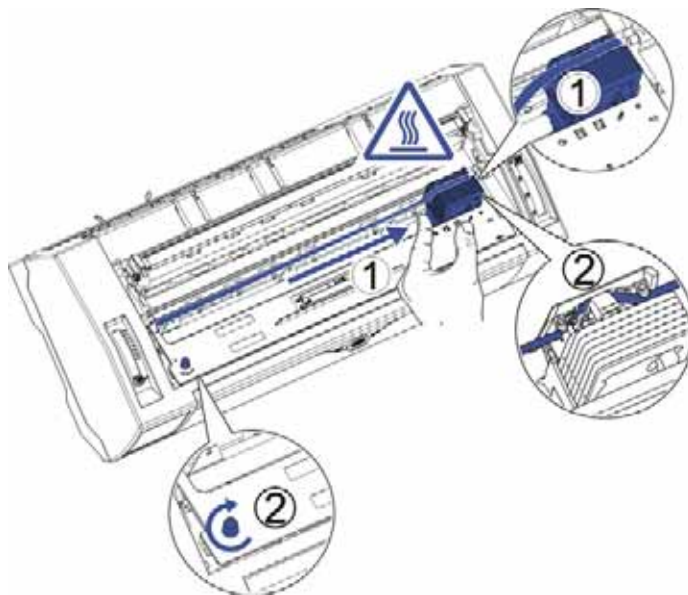

6) Turn the knob on the left hand side several times in order to tighten the fabric, and the fabric will slides downwards into the correct position between printhead and ribbon mask after the moving.

7) Restore the upper friction assembly to its original position.



Printhead may be hot, please move the printhead by moving the carriage.

3 Installing the paper

The printer can handle either single sheets or continuous forms. The printer is able to print up to 5 copies (original plus 5).

i To ensure the print quality and protect the print head, set a proper print gap by the gap lever (see 3.1) for the form thickness and do not load folded, damaged, wrinkled, or curled paper.

3.1 Adjusting the print gap for various form thicknesses

The print gap lever is on the left side of the printer inside the top cover.

Take care to adjust the print gap lever to a suitable position whenever you change the number of copies being printed. Using the wrong print gap may cause print head damage or paper jams.

The recommended gap lever position for different form thickness is:

Paper type	Lever position
1-part	1
Original + 1 copy	2
Original + 2 copies	3
Original + 3 copies	4
Original + 4 copies	5
Original + 5 copies	6

The position "Ribbon" only is suitable for loading the ribbon. When the lever is set higher than appropriate it will result in poor print. The ribbon and head life will be shortened.

3.2 Paper path introduction

3.2.1 Cut sheet paper handling (front friction only)



- 1) Place the paper path lever to the cut sheet position.
- 2) Unlock the front cover with the latch to unfold the cut sheet support.
- 3) Adjust the gap lever if necessary; see [3.1](#).

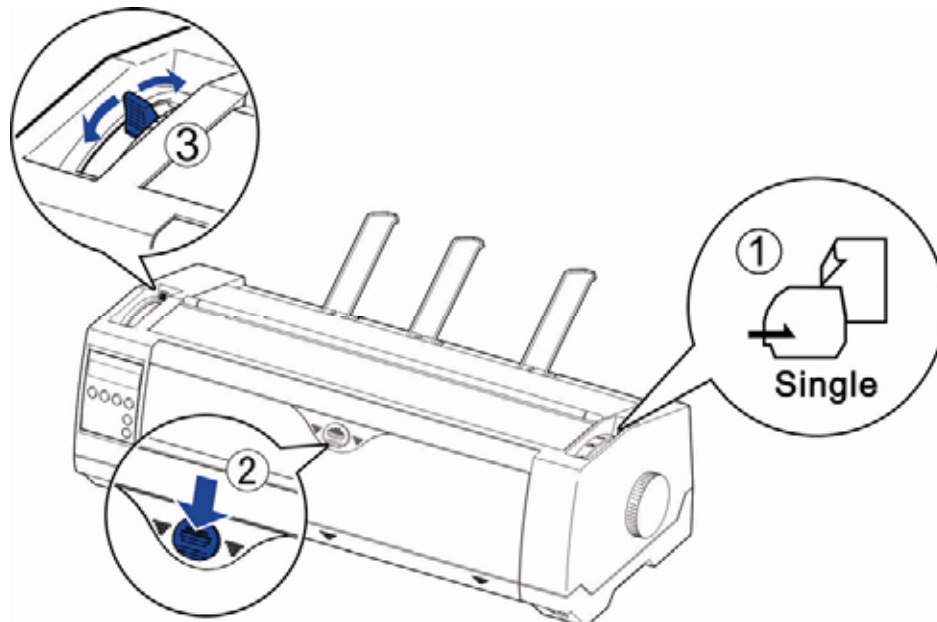

- 4) It is recommended to align the left paper guide exactly to the mark > | <. This marks the left edge of the stationery. Slide the right guide to the position of the right edge of the stationery.
- 5) Insert the stationery straightly all the way into the guided slot until it stops.

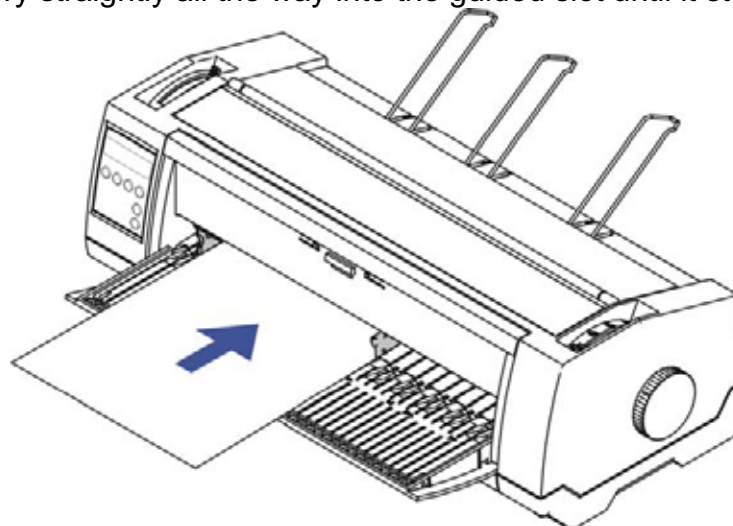

- 6) Press the load key to feed the paper to the correct print position, automatically. The printer clears the Paper End condition and goes into the ready or online state.

3.2.2 Fanfold paper handling

3.2.2.1 Front push tractors for fanfold



- 1) Close the front cover if previously opened. Switch the paper path lever to one of the desired tractor positions.
- 2) Move the paper path lever to the desired position.
- 3) Adjust the head gap lever if necessary.
- 4) Open the front cover by tilting the cover from bottom to the top, and make sure it's locked in place (see below pictures).

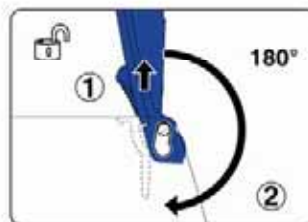
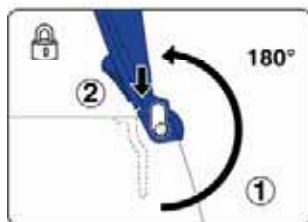
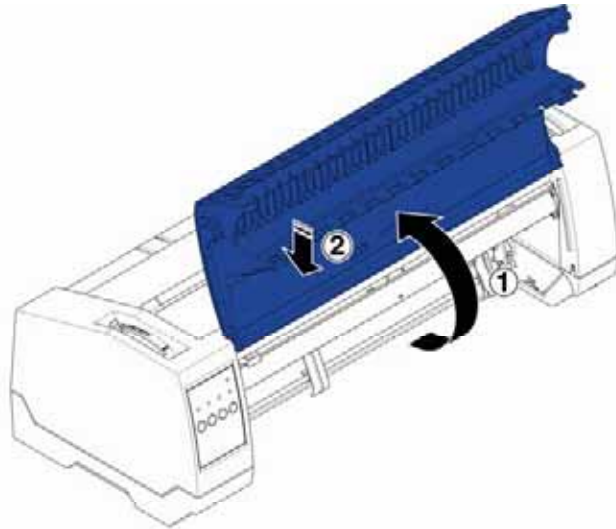
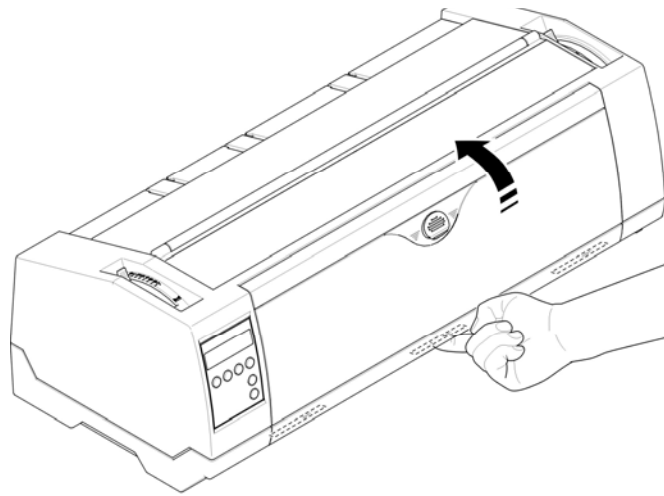

Lock the front cover in the way that is shown in the pictures. Make sure the front cover is locked.

- 5) If you do not need to adjust the left margin go to the next step. Open the right and left tractor flaps, insert fanfold paper into the left-hand tractor, and make sure that at least three paper transport holes are positioned on the tractor pins, close the tractor flap, open the latch lever and align the tractor so that the first printing position on the paper matches the IIIIXIII mark on the printer housing, then lock the lever again.

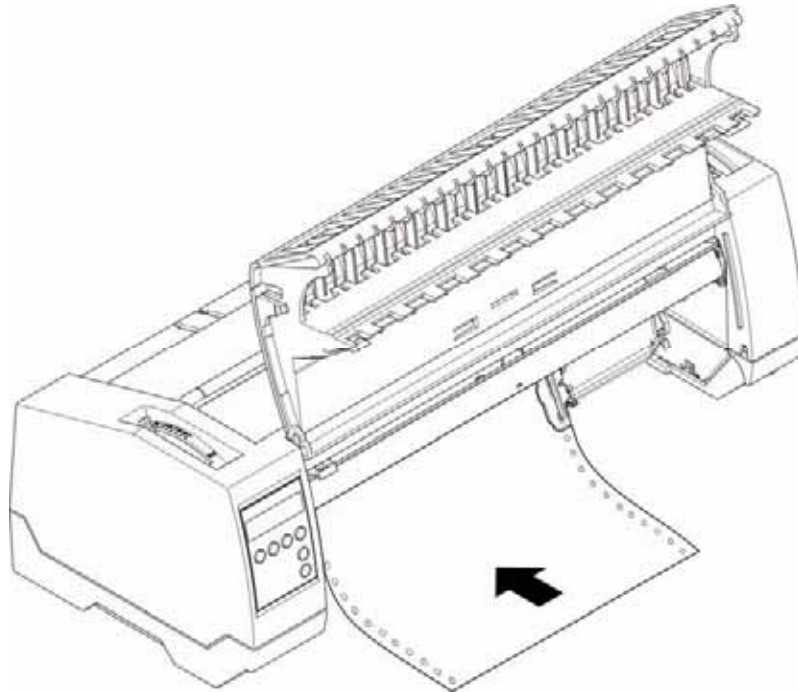

- 6) Align the right-hand tractor to the width of the paper and insert the paper (Make sure that it is inserted by the same length as on the left-hand tractor in order to avoid any paper jam). Then close the tractor flap and slide the tractor to the right until the paper is slightly tensioned, then lock the tractor.
- 7) Lower the front cover, switch the printer on.
- For LCD: The active paper source (**TrFront**) appears in the display, the paper will automatically load when the printer is in online mode and receives data from the computer. Also, you can press the load key (**key 4**) only to load paper before starting the printout.
- For LED: The paper will automatically load when the printer is in online mode and receives data from the computer. Also, you can press the load key (**key 2**) only to load paper before starting the printout.

Tally Dascom 2610

3.2.2.2 Rear tractors for fanfold

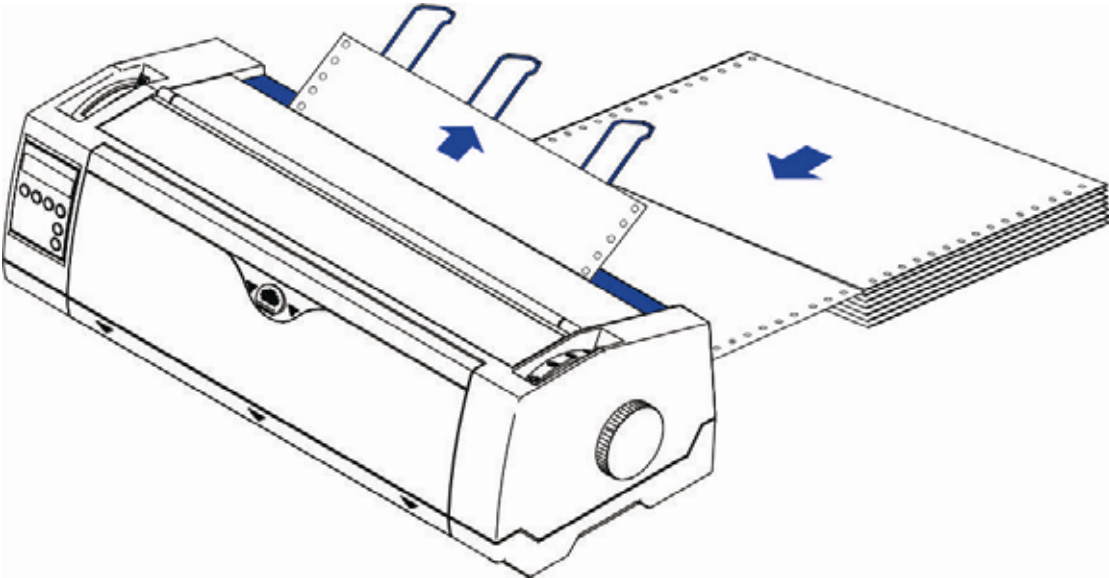
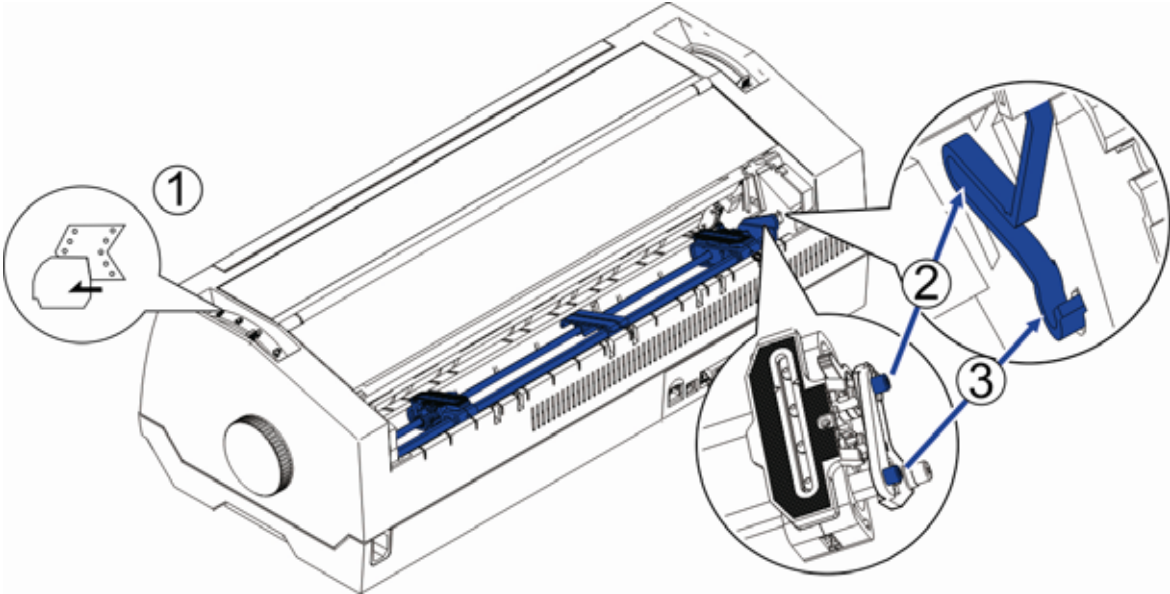

3.2.2.3 Top pull tractors for fanfold 

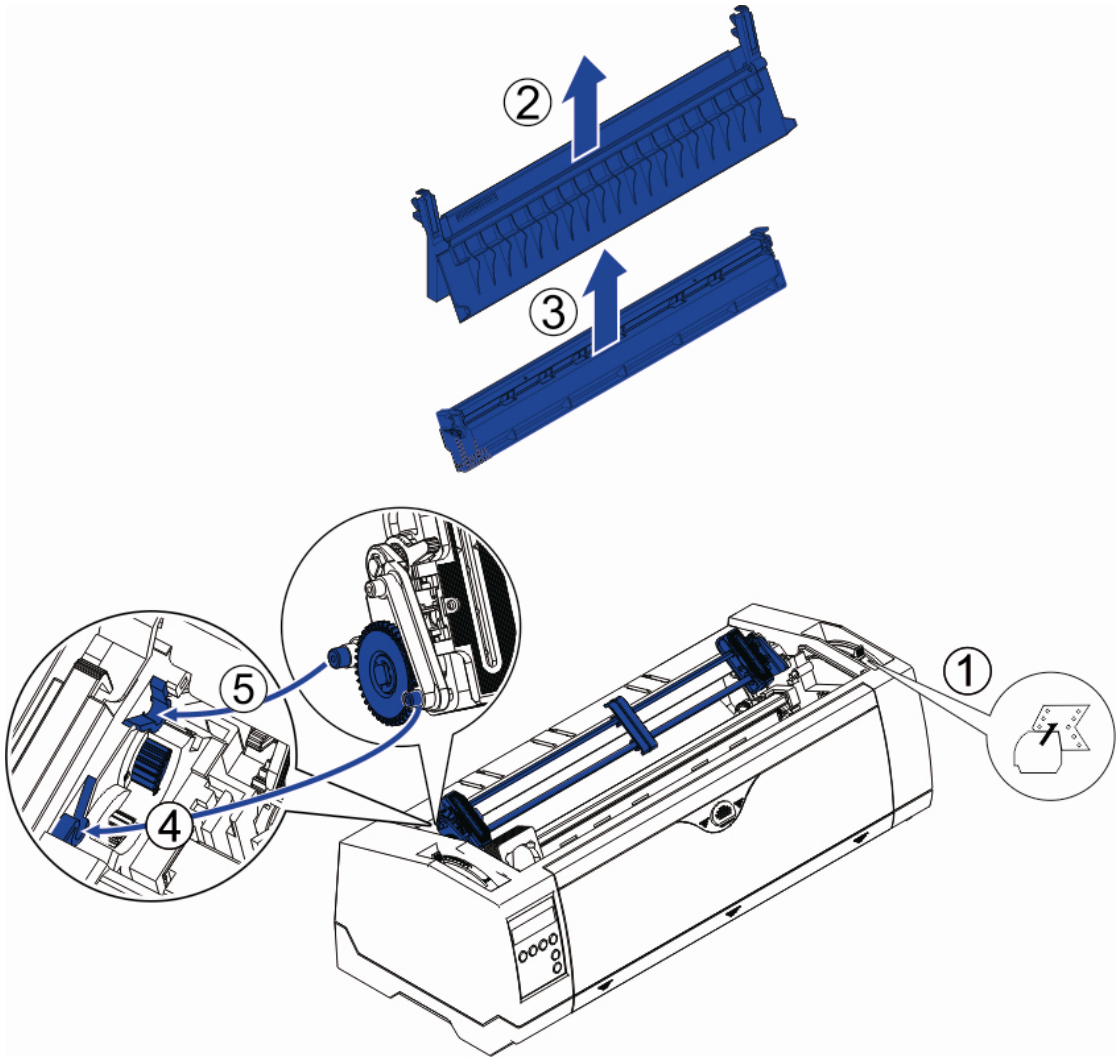

i For the steps 2 and 3 , please refer to the [2.3](#)

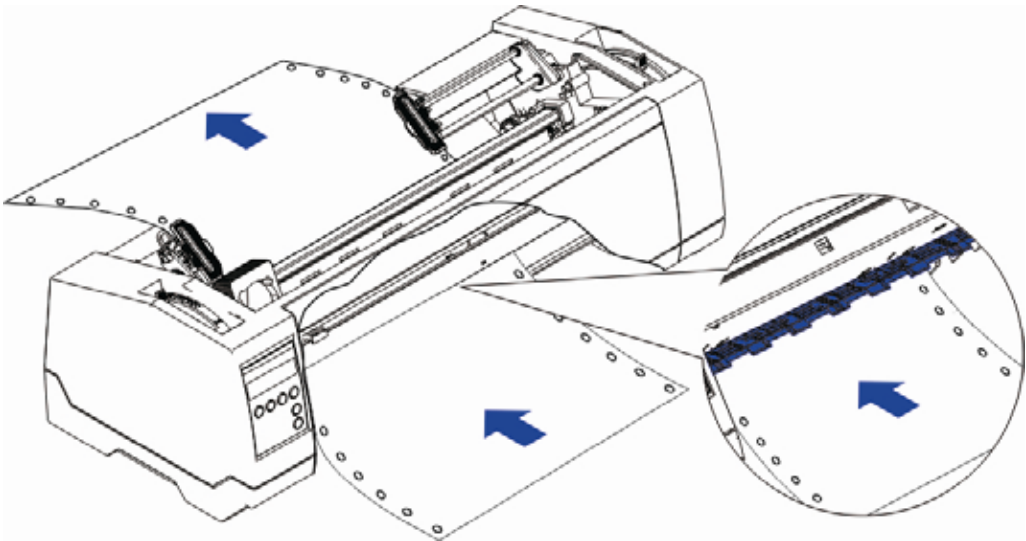

3.2.3 Top-Of-Form adjustment

For pull tractor (PullTr), follow the steps below to adjust the first print position:

- 1) Remove Paper from printer.
- 2) Power on the printer.
- 3) Lift the Top Cover so you can see the transparent ribbon guide in front of the print head.
- 4) Install the paper into the pull tractor.
- 5) Move the paper with the hand wheel so the perforation of the fanfold paper lies exactly at the top of the transparent ribbon guide.

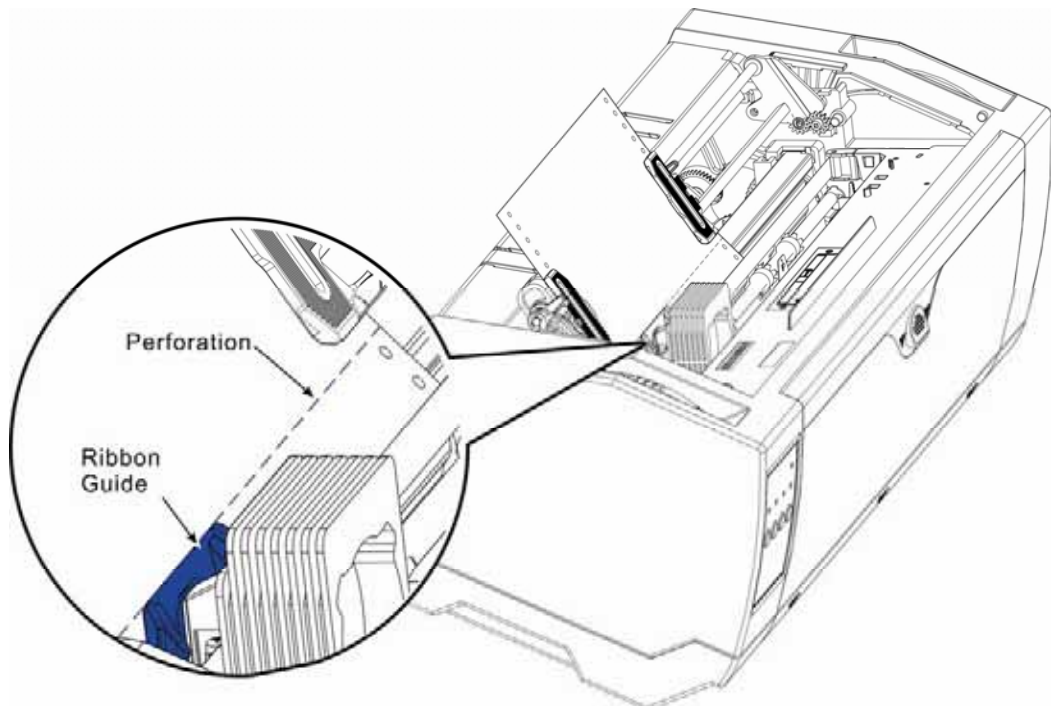

- 6) Close the Top Cover.
- 7) Press the Load key on the panel.
- 8) The printer now moves the paper to the correct first print position on a page (TOF).

4 Control Panel Operation

General functions for the keys are clearly designated on the Panel label. Some other special settings need pressing multiple switches simultaneously or holding some keys when powering on the printer. This Chapter will describe the functions of the keys and display (LEDs or LCD) on the Panel.

4.1 Operation of the LED Panel

4.1.1 Keys and Indicators

On the Panel, there are four keys, each with its name from left to right: **【Online】** , **【Load/Eject】** , **【Speed】** and **【Tear】** . The names of five indicators from left to right are: **【Online】** , **【Tractor】** , **【Speed】** , **【Paper Out】** and **【Power/Error】** above.

Please refer to the below diagram for the Panel layout:

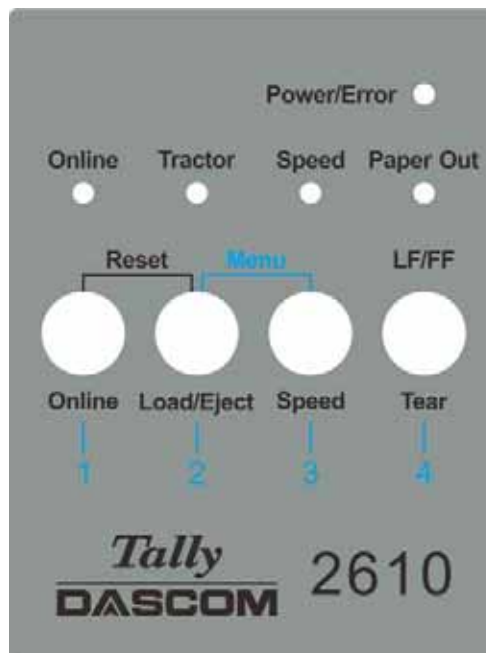

Below describes the function of each key/indicator:

◆ Indicators

- 1) **【Online】** lights up to indicate online and turns off to indicate off-line.
- 2) **【Tractor】** lights up to indicate utilizing tractors and turns off to indicate front friction state.
- 3) **【Speed】** Speed lights up to indicate higher print speed or is off if printing in higher quality based on selected Font.
- 4) **【Paper Out】** lights up to indicate out-of-paper warning and turns off to indicate paper loaded.
- 5) **【Power/Error】** normally lights up to indicate power on state. Please refer to 5. Error Indications on LED for the description on flashing of this indicator.

◆ Keys

1) 【Online】

a) Every press on this switch toggles the status between Online and Offline. When the printer is Online, it receives data from the host; while it is Offline, it stops the printing and signals the host to stop sending data.

b) Press the key 【Online】 for the below operations:

- Before and after special setup: Most of the special setup requires Offline operation. A press on 【Online】 key brings the printer Offline to carry out the special setup; after that, pressing 【Online】 brings the printer back online.
- Halt the printing for error recovery: Pressing 【Online】 brings the printer Offline for error recoveries like paper jam and so on. After the recovery, press 【Online】 to continue the printing.

2) 【Load/Eject】

If paper is already loaded:

Single sheet - - > The printer ejects the paper;

Tractor front and rear - - > The printer moves the paper in to Park position.

If paper is not loaded:

Transport the paper to the first print position (TOF).

3) 【Speed】

Toggles between high speed and high quality print depending on menu settings.

4) 【Tear】

When fanfold stationery are installed in an active tractor path, a press of this key advances the perforation of the stationery to the cutting edge of the tear-bar. This key is invalid for cut sheets.

Tally Dascom 2610

4.1.2 Online Operations



Function Name	Switch Operation	Function Description
Offline	{S1}	LED light ON: Online; LED light OFF: Offline;
Load/Eject	{S2}	<ul style="list-style-type: none"> ● Load: Load the paper from active paper path to first print position. ● Eject: Either park the fanfold paper or eject cut sheet paper.
Tear Off	{S4}	This is valid for tractor mode only. It feeds the form to the tear-off position. After tearing off the form, printing starts on the next TOF (top of form) by: <ul style="list-style-type: none"> ● pressing S4 once, or ● receiving print data from the host.

Tally Dascom 2610

4.1.3 Offline Operations

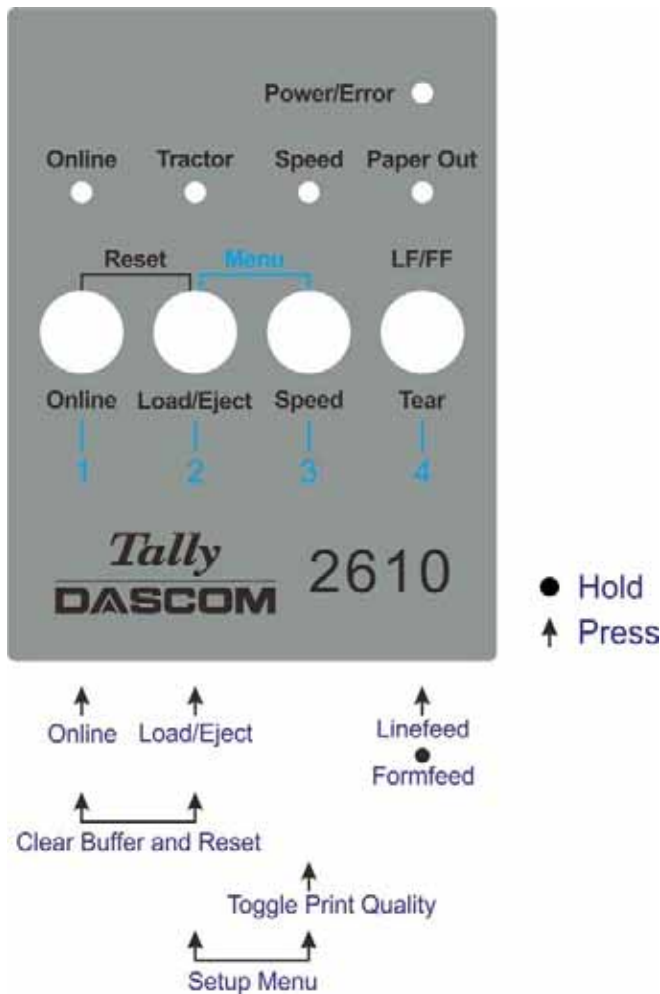

Function Name	Switch Operation	● Function Description.
Online	{S1}	● LED light ON: Online; LED light OFF: Offline.
Load/Eject	{S2}	● Load: Load the paper from active paper path to first print position. ● Eject: Either park the fanfold paper or eject cut sheet paper.
Speed	{S3}	● Toggle Between HS-Draft /Draft or NLQ/LQ.
LF/FF	{S4}	● Brief press: Linefeed, Longer hold: Formfeed.
Setup Menu	[S2] +[S3]	● Enter Printer Setup Menu.
Clear Buffer and Reset	[S1] +[S2]	● Clears the print buffer. ● Initializes the printer to power on configuration.

Detailed descriptions of the above functions:

◆ Speed

If LQ font is currently set in the configuration, lighting up of the **【Speed】** LED forces NLQ font printouts; turning off **【Speed】** indicates LQ printouts.

If Draft is currently set in the configuration, lighting up of the **【Speed】** LED forces HS Draft printouts; turning off **【Speed】** indicates Draft printouts.

◆ Setup Menu

See Chapter 5 for details.

◆ Clear Buffer and Reset

The printer has high capacity storage (buffer) to store the data from the host computer. Sometimes it is required to halt the printing to clear a fault. Resuming the printing at this point may cause erratic printouts because some of the un-processed data in the buffer may be truncated. Therefore, it is recommended clearing the buffer after the recovery with following procedures: (Turning off the printer is an alternative)

- 1) Terminate the print job in the host.
- 2) Press the **【Online】** key to bring the printer off-line. The printing will stop, but un-processed data still resides in the buffer.
- 3) Hold **【Online】** and **【Load/Eject】** keys simultaneously. The buffer will be cleared and the printer will automatically warm boot.
- 4) Probably you need to repeat step 2-3 times as the print job in the host spooler may be very large.

4.1.4 Power-On Operations

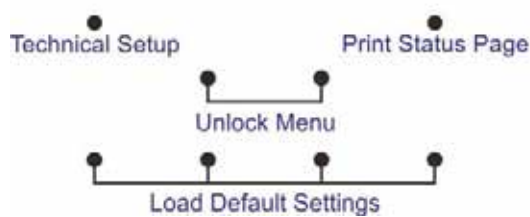

Function Name	Switch Operation	Function Description
Technical Setup	[S1]	● Start Technical Setup / Advanced Menu (This also includes Self Test Mode).
Menu Unlock	[S2]+[S3]	● Override Menu Lock Function if Menu is locked.
Status Page	[S4]	● Print Status Page.
Load Defaults	[S1]+[S2]+ [S3]+[S4]	● Load Default Settings.

Detail descriptions of the above functions:

◆ Technical Setup

See Chapter 5 for details.

◆ Menu Unlock

Pressing **【Load/Eject】** and **【Speed】** keys simultaneously overrides. Menu unlock function if menu is locked.

◆ Status Page

Print the setup of the printer (Menu).

◆ Load Defaults

Print the setup of the menu and the parameters.

4.2 Operation of the LCD Panel

- ◆ The *Online* mode is the printer's normal operating mode. Data from your computer can be received and printed.
- ◆ In the *Offline* mode the link between printer and computer is interrupted, i.e. no data can be received and printed.
- ◆ In the *Setup* mode you can either select the printer menu or carry out the quick-switch function. The quick-switch option was included so that you can change the most important parameters (for example adjustments, character density, font, paper path, adjustments directly without having to enter them via the menu. The settings for the parameters character density and font are lost when the printer is switched off. They can be selected permanently in the menu mode of the printer.
- ◆ In the *Menu* mode further printer settings (line spacing, size of the interface buffer etc.) can be altered and saved permanently.

4.2.1 The LC display

The LC display tells you all the important printer settings and informs you which functions are currently assigned to which keys.

The upper line informs you that the printer is either in online or offline mode (in the example below the printer is in the Online mode), and the selected paper path (below: **TrFront** = tractor front mode).

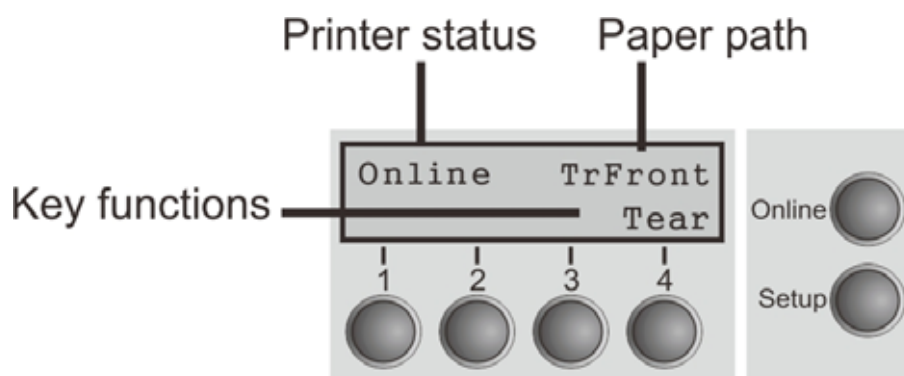

4.2.2 Online mode

After switching on, the printer is automatically set to online mode. Only in this mode can it receive data from the computer.



- **Online** key: Toggle between Online and Offline mode.
- **Tear** key (4): Activates the tear function when fanfold paper is loaded.
If **Load** is displayed above this key, no paper is loaded in the printer or the paper is in park position. In this case the display switches between **Online** and **Park Position**. Press the key to feed paper to the printing position.
- **Setup** key: Sets the printer to setup mode.

4.2.3 Offline mode

Only in this mode is it possible to perform step, line, or form feeds from the control panel, however, data cannot be received.

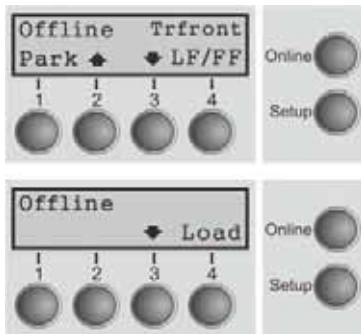

- **Park** key (1)
If fanfold paper is loaded in the printer, it is fed to the park position or the tear position. If a single sheet is loaded, it is ejected.
- **↑** key (2)
Each press: Paper is transported upwards step by step.
Holding: Continuous transport upwards.
- **↓** key (3)
Each press: Paper is transported downwards step by step.
Holding: Continuous transport downwards.
- **Load** key (4)
No paper in the printer: The press on this key loads the paper to the first print position.
Paper in the printer:
Each press: performs a line feed (LF).
Holding: performs a form feed (FF).
- **Setup** key: Sets the printer to setup mode.
- **Online** key: Sets the printer to online mode.

4.2.4 Setup mode

In this mode, the following settings are available:



- **Setup** key: Sets the printer to setup mode, in which the following settings can be selected.
- **Menu** key (1): Other menu settings. Access may be disabled by menu settings (see note below).
- **Adjust** key (2): Sets the Tear position and first printing line (TOF). If you have the PullTr (Pull - Tractor) selected Adjust is not available.
- **Char** key (4): Sets the font and the number of characters per inch temporarily.



Access to the other menu settings (Menu) may be disabled by the manufacturer.

Proceed as follows to release this lock temporarily.

- 1) Switch off the printer for approx. 5 seconds.
- 2) Switch the printer on again keeping the Setup key pressed.

4.2.5 Power on functions

If you keep one of the following keys pressed during power-on until the printer has completed initialization, the corresponding function is activated:

- ◆ If you keep the **Online** key depressed while turning on the printer, you enter the printer's advanced menu mode. The advanced menu mode is described in the section [5.4.2](#) of this manual.
- ◆ If you keep the **Setup** key depressed while turning on the printer, you regain access to the printer menu if you had locked it before with the help of the Menu Lock function.
- ◆ If all four **function** keys (keys 1 to 4) are depressed simultaneously while turning on the power, all printer settings are reset to the default values, except the **Forml** (Form length) setting in advanced menu mode.
- ◆ Holding Function key 4 while turning on the printer prints out the parameter settings.

5 Setting parameters for the printer

(Programming via the control panel)

Apart from being able to control your printer via the applications software you use, you can also program the printer directly. There are two programming options you can use:

- ◆ Programming via the control panel.
- ◆ Programming via the interface using Escape sequences or control codes.

i **Settings made by escape sequences have priority over settings made in menu mode; therefore they will override these.**

Programming via the interface gives you far greater freedom for designing your printed pages, however, it is also a more sophisticated method and requires some experience with programming languages and printer control systems.

All programming via the interface is lost after you turn off the printer, whereas the programming carried out using the control panel is saved and stored even after you turn off the printer.

5.1 Setting the parameters through the LED Panel

This chapter describes the handing of the operator's panel without optional display.

Firstly bring the printer Offline. Pressing **【Load/Eject】** and **【Speed】** keys simultaneously activates the parameters setting operation.

5.1.1 Fine tuning the TOF and Tear positions

Below describes how to set TOF demonstrating the general procedures of parameters configuration via an LED panel (This procedure is valid for front (TrFront) and rear tractor (TrRear) only):

- 1) First load fanfold paper in one of the tractors and bring the printer Offline. Pressing **【Load/Eject】** and **【Speed】** keys simultaneously activates the parameters setting operation. The printer prints out 2 lines of key assignments valid for the parameter setting operation.

Key 1	Key 2	Key 3	Key 4
Menu	Adjust		Char

- 2) Press **【Load/Eject】** (i.e. Key 2 in the listed assignment) to enter the operation. The printer then lists the below line.

TOF	Tear
-----	------

- 3) “TOF” sets the first printing position from the top edge of the page. “Tear” sets the desired perforation position. Press **【Speed】** (i.e. Key 3) to activate the TOF setting. The printer responds with the below line.

FormAdj 12/72” *	Set	<	>	Exit
------------------	-----	---	---	------

- 4) The printer feeds the form to a position where the bottom edge of the first printing line (TOF) is aligned with the tear edge of the printer. Press **【Load/Eject】** or **【Speed】** to

Tally Dascom 2610

increment or decrement the TOF value. After adjustment, press Key 1 (Set) to save the change.

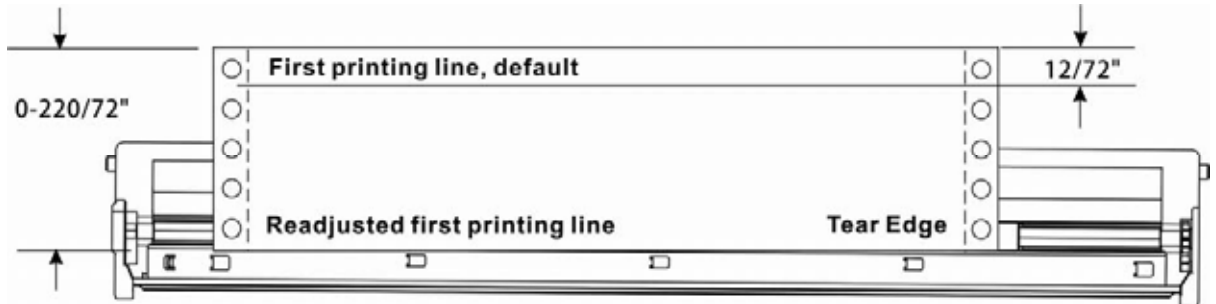

i Set the Tear position in the same way. Move the perforation of the stationery exactly to the Tear Edge.

5.1.2 Select a font

Below example demonstrates how to select Roman LQ font type under the Char setting.

- 1) First, load fanfold paper to one of the tractors and bring the printer Offline. Pressing **【Load/Eject】** and **【Speed】** keys simultaneously activates the parameters setting operation. The printer prints out 2 lines of key assignments valid for the parameter setting operation.

Key 1	Key 2	Key 3	Key 4
Menu	Adjust		Char

- 2) Press **【Tear】** (i.e. Key 4 in the listed assignment) to enter the Character setting. The printer then lists the below line:

Font	CPI
------	-----

- 3) "Font" allows selecting desired font type and "CPI" allows setting desired character pitch. Press **【Load/Eject】** (i.e. Key 2) to enter the Font submenu. The printer responds with the below line:

HS-Draft *	Set	<	>	Exit
------------	-----	---	---	------

- 4) HS-Draft * indicates the current selection. Set means to save the change. < selects the previous item. > selects the next item. Exit exits the menu. Here, press **【Speed】** (i.e. Key 3) to show the next font. Keep pressing **【Speed】** until the print shows Roman:

Roman LQ	Set	<	>	Exit
----------	-----	---	---	------

- 5) Press **【Online】** to save the change of font type to Roman. The printer sounds the buzzer and prints the below line to confirm successful change.

Roman LQ *	Set	<	>	Exit
------------	-----	---	---	------

i Modify the CPI in a similar way if desired (these two are only temporarily stored).

5.1.3 Settings within Menu

Below example demonstrates how to select an Emulation within the Menu.

- 1) First load fanfold paper to one of the tractor and bring the printer Offline. Pressing **【Load/Eject】** and **【Speed】** keys simultaneously activates the parameters setting operation. The printer prints out 2 lines of key assignments valid for the parameter setting operation.

Key 1	Key 2	Key 3	Key 4
Menu	Adjust		Char

- 2) Press **【Online】** (i.e. Key 1) to get into Menu operation. The printer prints:

Back	Print	Menu	Next
------	-------	------	------

- 3) Press **【Tear】** (i.e. Key 4) repeatedly till “Emulation” appears on the printout:

Back	ESCChar	Emulation	Next
------	---------	-----------	------

- 4) Press **【Speed】** (i.e. Key 3) to get into emulation configuration. The printer prints:

Epson LQ-2550 *	Set	<	>	Exit
-----------------	-----	---	---	------

- 5) Epson LQ-2550 * indicates the current emulation is LQ-2550. Set means to save the change. < selects the previous item. > selects the next item. Exit leaves the menu. Press **【Speed】** (i.e. Key 3) to show the next emulation:

Epson LQ-2170	Set	<	>	Exit
---------------	-----	---	---	------

- 6) Press **【Online】** (i.e. Key 1) to save the selection of Epson LQ-2170 emulation. The printer sounds the buzzer and prints the below line to confirm successful change.

Epson LQ-2170 *	Set	<	>	Exit
-----------------	-----	---	---	------



See [5.4.1](#) for a full list of valid settings.

5.2 Setting the parameters through the LCD Panel

This chapter describes the handling of the operator's panel with optional display.

5.2.1 Enabling access to menu mode

The menu can be locked by default to protect it from accidental or unauthorized access. Proceed as follows to release this lock temporarily.

- 1) Switch off the printer for approx. 5 seconds.
- 2) Switch the printer on again keeping the Setup key pressed.

Calling up the menu



You can access the menu in the following way:
Press the Setup key. The printer switches to Setup mode. (The Setup mode can be selected both in the Online and Offline mode)

To access the printer menu, press the key directly underneath the word Menu (1).

5.2.3 Menu configurations

Every printer is shipped with factory default settings. Basic settings such as emulation, character size, form length etc., which many applications make use of, are set. At the end of this chapter you will find a menu printout which shows you the printer's default settings.

Your printer allows you to set and use five independent menu configurations. If one of your applications, for example, requires an IBM printer while another program works better with an EPSON printer, you can set an IBM emulation configuration with the desired settings, and set the second configuration as an EPSON emulation.

The active menu is always the one you used last. When you switch on the printer for the very first time, menu no. 1 is loaded. Menu no.1 only remains active until you load another menu. The last active menu is stored even after the printer is switched off and is reloaded automatically when the printer is switched on again.

For example, to change from menu no. 1 to menu no. 3:



Press Setup key.

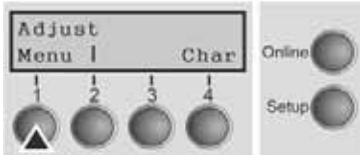

Press Menu (1) key.



Press Menu (3) key.



Now the following message appears in the LC display:
Now press the < (2) or > (3) key repeatedly until Load Menu=3 appears.

Then select menu no. 3 as the current setting using the Set key (1). The currently active setting is marked with an asterisk (*).



If changing menus it is possible that the printer initializes due to different emulation settings.

Tally Dascom 2610

Menu Printout

	Menu 1	Menu 2	Menu 3	Menu 4	Menu 5	Current
Font	HS-Draft	HS-Draft	HS-Draft	HS-Draft	HS-Draft	HS-Draft
CPI	10 CPI	10 CPI	10 CPI	10 CPI	10 CPI	10 CPI
LPI	6 LPI	6 LPI	6 LPI	6 LPI	6 LPI	6 LPI
Skip	0.0Inch	0.0Inch	0.0Inch	0.0Inch	0.0Inch	0.0Inch
ESCChar	ESC	ESC	ESC	ESC	ESC	ESC
Emulate	Epson LQ-2550	IBM Propr. XL24	Epson LQ-2550	Epson LQ-2550	Epson LQ-2550	Epson LQ-2550
Bidir	On	On	On	On	On	On
CG-Tab	Graphic	Graphic	Graphic	Graphic	Graphic	Graphic
CharSet	Extended	Extended	Extended	Extended	Extended	Extended
Country	E-US ASCII	Table 437	E-US ASCII	E-US ASCII	E-US ASCII	E-US ASCII
Sl.Zero	Off	Off	Off	Off	Off	Off
Auto-CR	On	On	On	On	On	On
Auto-LF	Off	Off	Off	Off	Off	Off
AutoFcar	ViewFcar-Off	ViewFcar-Off	ViewFcar-Off	ViewFcar-Off	ViewFcar-Off	ViewFcar-Off
Width	13.6Inch	13.6Inch	13.6Inch	13.6Inch	13.6Inch	13.6Inch
LeftMrg	0/10"	0/10"	0/10"	0/10"	0/10"	0/10"
RightMrg	136/10"	136/10"	136/10"	136/10"	136/10"	136/10"
Barcode	Off	Off	Off	Off	Off	Off
Barmode	Unsecured	Unsecured	Unsecured	Unsecured	Unsecured	Unsecured
Single						
Formlen	Fanfold 12"	Fanfold 12"	Fanfold 12"	Fanfold 12"	Fanfold 12"	Fanfold 12"
FormAdj	12/72"	12/72"	12/72"	12/72"	12/72"	12/72"
TrFront	*	*	*	*	*	*
Formlen	Fanfold 12"	Fanfold 12"	Fanfold 12"	Fanfold 12"	Fanfold 12"	Fanfold 12"
FormAdj	12/72"	12/72"	12/72"	12/72"	12/72"	12/72"
TrRear						
Formlen	Fanfold 12"	Fanfold 12"	Fanfold 12"	Fanfold 12"	Fanfold 12"	Fanfold 12"
FormAdj	12/72"	12/72"	12/72"	12/72"	12/72"	12/72"
PullTr.						
Formlen	Fanfold 12"	Fanfold 12"	Fanfold 12"	Fanfold 12"	Fanfold 12"	Fanfold 12"
FormAdj	12/72"	12/72"	12/72"	12/72"	12/72"	12/72"
Interf.	Shared					
Buffer	256 KB					
CX-bid	On					
Menu	1					
FcarAdj TrFront	0/72"					
FcarAdj TrRear	0/72"					
FcarAdj PullTr.	0/72"					
Quietm.	Off					
Pap.back	normal					
Sound	On					
FFmode	Off					
Wrap	On					
Physim	0/10"					
Hvy Form	Off					
GrSpeed	high					
Jobcntl	Off					
Eject	Top					
UltraDr.	Off					
Serial						
Baud	9600					
Format	8Bit No 1Stop					
Protocol	XON/XOFF?					
DTR	DTR					
ETH-INT	OCTET 1	OCTET 2	OCTET 3	OCTET 4		
IP Addr	192	168	0	22		
Gateway	192	168	0	10		
Subnet	255	255	255	0		
IP Get Method	DHCP					

5.2.4 Menu handling

You can navigate in the current menu using the four function and selection keys arranged below the LC display field. Each function and parameter displayed in the LCD is executed or selected by the corresponding key below, respectively. Usually two parameter groups are combined at one level. In the following example, these are the LPI and Skip parameter groups.

If you do not wish to change one of the two parameters you can either press the Next key (to access the two following parameter groups in the menu), or you can press the Back key (to access the two previous parameter groups in the menu).

If you want to change a setting, (e.g. the line density), then press the LPI key (LPI = lines per inch) to access the actual parameter level.

The currently valid setting is marked by an asterisk (in the example below the current setting is 6 lpi). With the < and > keys you can view the other parameters available for this setting.

Example:

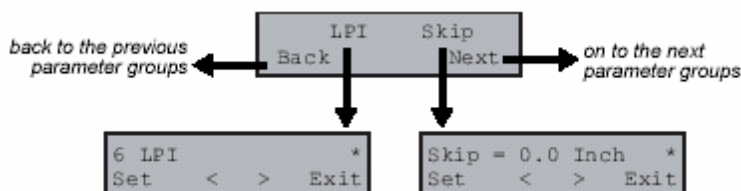

Save settings

Once the desired parameter is displayed on the LC display, you can save it by pressing the Set key. The parameter is then set and the printer automatically displays the parameter groups again. With the Exit key you can leave the sublevel without saving your changes.

5.2.5 Selecting the LC display language

This section describes how to make settings in the menu, using the selection of the national language as an example.

In this user guide all LC display messages are shown in English language. Your printer offers also the possibility to show the display messages in German, French, Italian, Spanish or Turkish language. This example shows how to change from the English language to the German language. The same procedure applies to the other languages (French, Italian, Spanish and Turkish).



Select the Setup mode by pressing the Setup key.



Setup mode and Menu mode may be disabled. Hold down the Setup key while switching on the printer to enable menu mode. If you want to enable access to this mode permanently, you need to change the appropriate setting in the menu.

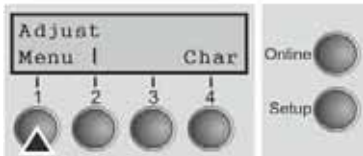

Press the next key (4) several times until the display indicates Language.



Press the Language key (3).



The display now changes to Parameter mode and indicates English in the top line.

The lower line displays Set and Exit. The two arrows < (2) and > (3) represent the symbols for parameter selection (“<” indicates descending and “>” ascending). Press the < (2) or > (3) key until the desired language is displayed, in our example German.



Save your selection by pressing the Set key (1). An acoustic signal verifies this action.

You can exit Parameter mode without saving a setting by pressing the Exit key (4), the old setting is retained.

After saving your setting (Set), the display in our example Ges.Men indicates the following text:



This setting is retained even after switching off your printer. Terminating Setup mode press either the Setup key to change into Offline mode or the Online key to change to Online mode.

5.3 Menu structure

The menu structure of your printer may be slightly different from the example shown here, depending on the printer software.

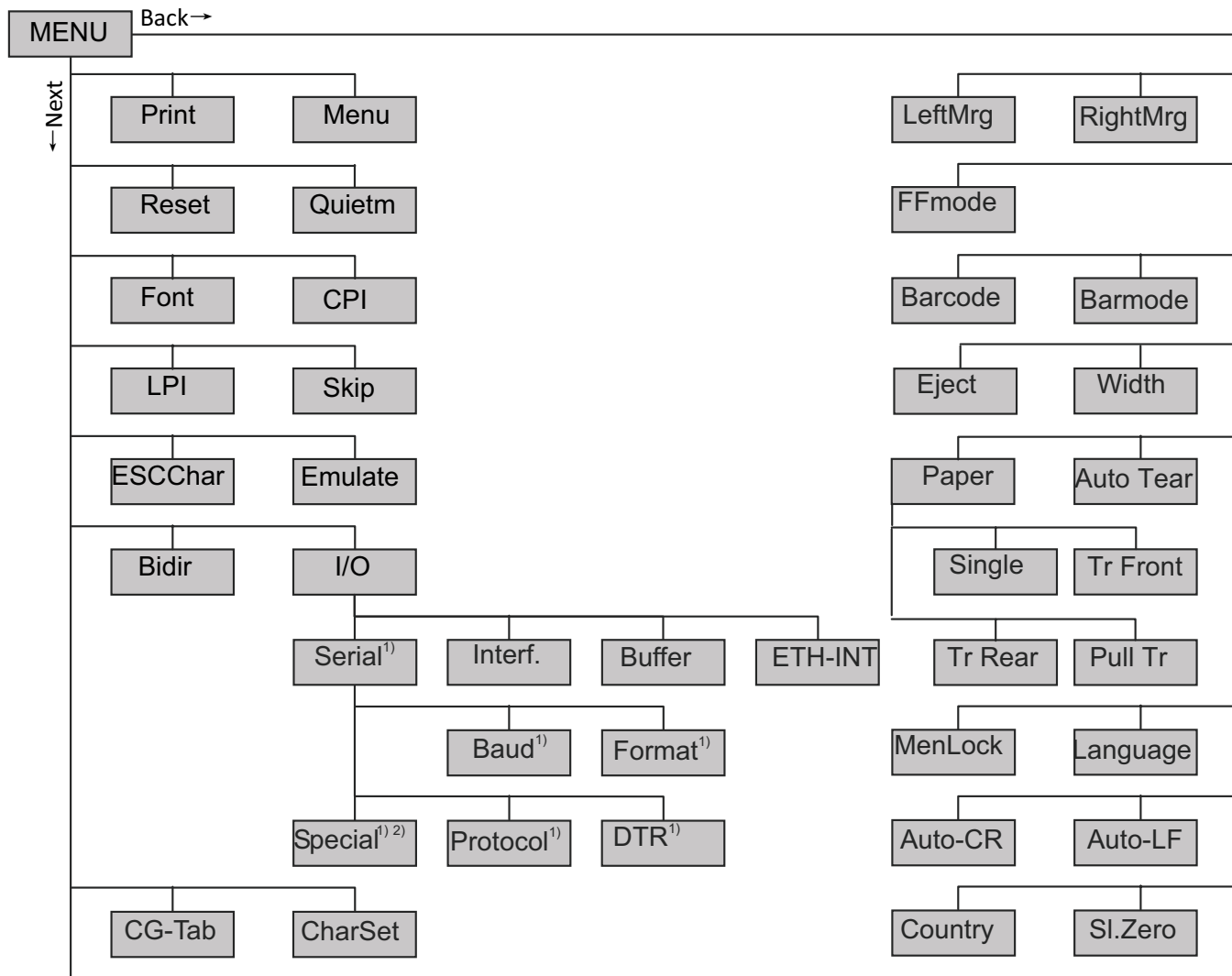

1) Only with optional serial interface

2) Only if ENQ/STX, ETX/ACK or ACK/NAK protocol is selected

5.4 Full list parameters setting

In order to meet individual requirements of printer functionality, users may modify the printer configuration settings accordingly as follows: start by pressing [Load/Eject] + [Speed] in offline mode. The printer will enter Main Menu settings setup mode. Follow the instructions printed on how to do the required setting changes. When a new setting is saved, it becomes effective, even when printer is power cycled.

5.4.1 Menu Configuration list

Menu	Valid Settings			Function
Adjust	TOF	Tear		Setting the tear position. Setting the first printing line (TOF).
Print				Print the menu settings.
Menu	Load Menu=1	Load Menu=2		A menu is loaded, you can choose between five menus.
	Load Menu=3	Load Menu=4		
	Load Menu=5			
Reset	Reset Menu	Yes	No	Press the No (1) or Yes (2) key to select the desired setting. All manually altered settings in the current menu are lost when it is reset to the default settings. We therefore recommend that you print out the menu first.
Quietm	Off	On		Switches between normal and quiet mode printing. For all printing modes, the print-out is made with the bidirectional method in quiet mode printing. In the first step the first row of pins is activated, during the second step the second row is used.
Font	HS-Draft	Draft	Roman NLQ;	This parameter selects the character style and its quality permanently.
	Roman LQ	Roman PS NLQ	Roman PS LQ	
	CourierNLQ	Sans Serif NLQ	Sans Serif LQ	
	Courier LQ	S Serif PS NLQ	S Serif PS LQ	

Tally Dascom 2610

	Prestige NLQ	Prestige LQ	Script NLQ	
	Script LQ	OCR-B NLQ	OCR-B LQ	
	OCR-A NLQ	OCR-A LQ	Orator NLQ	
	Courier I NLQ	Courier I LQ	Orator LQ	
	Souvenir NLQ	Courier I PS NLQ	Gothic NLQ	
	Souvenir LQ	Courier I PS LQ	Gothic LQ	
CPI	10 CPI , 12 CPI, 15 CPI, 17.1 CPI, 20 CPI, 5 CPI, 6 CPI, 7.5 CPI, 8.6 CPI.			Sets the characters per inch (character pitch). The higher parameter the smaller character spacing.
LPI	6 LPI , 8 LPI, 12 LPI, 2 LPI, 3 LPI, 4 LPI.			Sets the lines per inch (line density). The higher parameter the smaller line spacing (random LPI can be selected via the ESC sequences).
Skip	Skip=0.0 Inch , Skip=0.5 Inch, Skip=1.0 Inch, Skip=1.5 Inch, Skip=2.0 Inch, Skip=2.5 Inch, Skip=3.0 Inch, Skip=3.5 Inch.			Skips the perforation; 7 different values (in inches) can be defined.
ESCChar	ESC ESC+\$\$			Selects the start signal for control sequences. Setting ESC: Only character Escape can be used. Setting ESC+\$\$: Character Escape or alternatively two \$ characters (\$\$) can be used.
Emulate	Epson LQ-2550 Epson LQ-2170 IBM Propr. XL24 IBM ProXL24+AGM MTPL			Selects the emulation. When a printer understands the control set written for another printer type, it is said to emulate the other printer.
Bidir	Bidir=On Bidir=Off			Setting On: Printer prints in both directions (bidirectional). Setting Off: Printer prints only in one direction (from left to right).
I/O	Serial	Baud	Baud=9600 Baud=9200 Baud=600 Baud=1200 Baud=2400 Baud=4800	Selects the data transmission rate (baud rate) (baud=bit per second).

Tally Dascom 2610

	Format	<u>8Bit No 1Stop</u> 8Bit No 2Stop 8Bit Even 1Stop 8Bit Odd 1Stop 8Bit Mark 1Stop 8Bit Spc 1Stop 7Bit No 2Stop 7Bit Even 1Stop 7Bit Odd 1Stop 7Bit Odd 2Stop 7Bit Mark 1Stop 7Bit Spc 1Stop 7Bit Mark 2Stop 7Bit Spc 2Stop	This parameter serves to define the number of data bits, the parity check for received data bytes and the number of stop bits per data byte.
	Protocol	<u>XON/XOFF</u> Robust- XON/XOFF ENQ/STX ETX/ACK ACK/NAK	This parameter serves to select the type of protocol, i.e. a certain set of rules and procedures for ensuring error-free data exchanges between computer and printer.
	DTR	<u>DTR=DTR</u> DTR=READY	Defines the conductor to which the DTR signal is connected (DTR=Data Terminal Ready).
	Interf.	<u>Interf.=Share</u> Interf.=Parallel Interf.=Serial	Selects the interface. Printer is configured either for parallel. Ethernet or optional serial connection or in automatic change for the parallel or the optional serial interface (Shared).
	Buffer	Buffer=0 KB Buffer=32 KB Buffer=64 KB Buffer=96 KB Buffer=128 KB Buffer=160KB Buffer=192KB Buffer=224KB <u>Buffer=256KB</u>	Selects the size of the interface buffer.

Tally Dascom 2610

	ETH-INT	IP-Addr	Octets 1-4 0 to 255	Input of the IP address of the printer This menu level offers the possibility to set the IP address, which is divided into four digit groups (octet 1 to 4).
		Gateway	Octets 1-4 0 to 255	Input of the Gateway address of the printer.
		Subnet	Octets 1-4 0 to 255	Input of the Subnet mask address of the printer.
		IP Get M	DHCP BOOTP Static	Selects the way of administrating the IP address.
		Banner	Off On	Specifies whether a banner page is to be printed out, when using the LPD/LPR protocol.
		EthSpeed	Auto-Sense	The transmission speed is detected automatically.
			10Mbit Half	Sets the transmission speed to 10 MBit half duplex per second.
	10Mbit Full		Sets the transmission speed to 10 MBit full duplex per second.	
	100Mbit Half		Sets the transmission speed to 100 MBit half duplex per second.	
		100Mbit Full	Sets the transmission speed to 100 MBit full duplex per second.	
CG-Tab	Graphic DLL Italic			Only available for Epson LQ-2550/LQ-2170 emulation. Either the Epson character set Italics or the IBM graphics character set or a DLL (download) character set, as defined before, can be activated in the code range from hex. A0 to hex. FE.
CharSet	Extended Standard			Selects the IBM standard characters or the extended IBM characters.
Country	E-USASCII	E-France	E-German	Selects the national character set. These character sets can be used according to the selected emulation.
	E-UK	E-Denmark I	E-Sweden	
	E-Italy	E-Spain I	E-Japan	
	E-Norway	E-Denmark II	E-Spain II	
	E-L.America	E-Korea	E-Legal	
	ISO8859-1	ISO8859-1 SAP	ISO8859-2	
	ISO8859-5	ISO8859-7	ISO8859-9	
	ISO8859-15	ELOT-928	BRASCII	
	Abicomp	Roman8	US-ASCII	
	French	German	Italian	
	Swedish	Norwegian	Spanish	
	Portuguese	Greek DEC	Cro-ASCII	

Tally Dascom 2610

	Coax/Twinax	Table 437	New-437		
	Table 737	775 Baltic	Table 850		
	New-Dig 850	Table 851	Table 852		
	Table 857	Table 858	Table 860		
	Table 861	Old-Code 860	Table 863		
	Flarro 863	Table 865	865 Hebrew		
	Table 866	866 Bulgaria	866 Ukraine		
	866 Kazakhst	Kamenicky	Mazovia		
	Siemens Turk	DEC Turkish	Table 1250		
	Table 1251	Table 1252	Table 1253		
	Table 1254	Table 1257			
Sl.Zero	Sl.Zero=Off	Sl.Zero=On		Selects if normal zero (0) or the slashed zero (Ø) is printed.	
AutoCR	On	Off		Switches the automatic carriage return on or off after receiving the signal LF (line feed).	
AutoLF	Off	On		Switches the automatic line feed (LF) on or off after receiving the signal CR (carriage return).	
Menlock	Off	Menu	All	<p>With MenLock=Off, all functions and settings are accessible without restriction in Online, Offline and Setup mode.</p> <p>If MenLock=Menu is activated, all functions and settings are still accessible in Online and Offline mode, however, in Setup mode you can only access the parameter groups Adjust (setting the print head gap [Head], top of form [TOF] and tear position [Tear]), Paperway (setting the paper path), Font (setting the font) and the character spacing (CPI), while access to Menu mode (Menu key) is disabled.</p> <p>If you select MenLock=All, you can access the Online/Offline, Load/Park, Paper and Paper Feed (LineFeed/Form Feed, /) functions in Online and Offline mode while Setup mode is disabled. In this case, the Setup menu can only be called up by holding the key Setup while switching on the printer.</p>	
Language	English	German	French	Italian	The menu can be shown in six languages.
	Spanish	Turkish			
Paper	Single	TrFront	TrRear	PullTr	Selects the paper parameters Formlen (form length), FormAdj (first printing position/TOF) separately for each paper source in the current menu.

Tally Dascom 2610

Formlen	Lines	=6 – 144 Default 6LPI = 66	Sets the form length via line formats. Please note that the adjustment in Lines depends on the selected LPI. For example 8 LPI at a selected line number of 96 lines results in a form length of 12 inches (96lines/[8lines/inch]) = 12 inches. The selectable range is between 3 and 21 inches, i.e. for 2 LPI from 6 to 42 lines and for 12 LPI from 24 to 262 lines. If the form length is set it will not be changed by changing the LPI later on.
	Standard	No format DIN A3 (420 mm) DIN A4 (297 mm) DIN A5 (210 mm) DIN B5 (250 mm) DIN B6 (176 mm) DIN C6 (162 mm) Executive 10.5" Letter 11" Fanfold 12" Legal 14"	Selects the form length by standard formats. Using Standard, different paper formats can be selected directly, e.g. DIN A4, Legal, Letter. The Menu indicates No format if a value is selected by the Line function or ESC sequences, which does not correspond to a standard format.
FormAdj	FormAdj=0 - 134/72" Default 12/72"		Sets the first print position of a form in n/72 inch, separately adjustable for each paper path.
Autotear	ViewTear =Off View=1s/3s/6s Tear=1s/3s/6s Tear at TOF		The auto tear function or the auto view function can be selected as desired. When auto view is switched on, the last printed text is visible. As soon as data is received the paper moves to the "normal" print position. After printing the printer waits for the given interval to bring the paper once more to the auto view position. The paper is in the tear off position when auto tear is switched on, the perforation of the positioned at the tear off edge of the printer. If data is received, the paper returns to the normal print position. After printing, the printer waits for the given interval to bring the paper once more to the tear off position. If the tear off edge does is not aligned with the perforation of the paper then this can be corrected.
Width	Width=13.6Inch		Selects the line length in inches. With the setting of 8 Inch, the printer operates like

Tally Dascom 2610

	Width=8Inch Width=13.2Inch	a printer with a width of only 8 inches.
Eject	<u>Eject=Top</u> Eject=Front	This is valid for single sheet mode only. It controls the exit direction of the friction sheet paper.
Barcode	<u>Off</u> On	With this function selected it is possible to print different barcodes and LCP (Large Character Printing).
Barmode	<u>Unsecured</u> Secured	Allows printing of normal characters on the left and right of the barcode.
FFmode	<u>Off</u> On	Specifies whether a form feed is to be performed when the paper reaches the top print line.
LeftMrg	LeftMrg= <u>0</u> - 134/10"	The left print margin can be set to a fixed value.
RightMrg	RightMrg=2 - <u>136</u> /10"	The right print margin can be set to a fixed value.

Tally Dascom 2610

5.4.2 Advanced Menu

Advanced Menu	Valid Settings		Function
ASCII80	8 inch wide print of test pattern		To check operational readiness, your printer contains a self-test routine which allows testing of the printer configuration, the print quality and correct operation of your printer
ASCII136	13.6 inch wide print of test pattern		
H-Dump			With the interface test (Hex-Dump/H-Dump) you can test data transmission from the computer to the printer. During this test, the data from the computer is printed out in two columns. The text in the left column is printed in hexadecimal format and in the right column in ASCII format.
Formlen	<u>12</u> " 11"		The Formlen function allows you to set the basic (default) form length to meet your requirements. 11 inches are usual in the USA, as opposed to 12 inches in Europe.
Paphand	Physlm	Physlm= <u>0</u> - 30/10"	Permanent (physical) setting of the left margin. This parameter cannot be changed by emulation dependent margin settings. Margin setting values entered by ESC sequences are added to the Physlm.
CX-bid	<u>CX-bid=ON</u> CX-bid=OFF		CX-bid=ON sets the parallel interface of the printer to bidirectional mode (IEEE 1284, Nibble mode), e.g. for Windows Plug & Play. CX-bid=OFF sets the interface to compatibility mode in order to ensure reliable operation with special external boxes.
Wrap	<u>Wrap=On</u> Wrap=Off		Wrap=On: If more characters than can be printed are transmitted per line, the characters which cannot be printed on this line are printed at the beginning of next line. Wrap=Off: If more characters than can be printed are transmitted per line, the characters which cannot be printed on this line are cut off.
Sound	<u>Sound=On</u> Sound=Off		When Sound=On, a beep is generated every second to notify that paper is empty

Tally Dascom 2610

Pap.back	<u>Pap.back=normal</u> Pap.back=dark	Pap.back=normal is the standard for normal paper. Pap.back=dark can be set to process paper with a grey back. Paper with a completely black back side cannot be used if the ink is carbon-based. However, the printer can handle aniline- based black paper (undefined colors).
Hvy Form	<u>HvyForm=ON</u> HvyForm=OFF	If you set HvyForm=ON, the printer prints the same line twice at double strike. This setting ensures that copy paper produces optimum results.
SerialN	factory set	With the SerialN function you have the possibility to change the 12 digit serial number of the printer. The number can be written with any ASCII character between hex 20 and hex 7E. LED Panel: The Serial Number cannot be set via menu instead you need to use the WebPanel
AssetN	10 digits empty	With the AssetN function you have the possibility to change the 10 digit asset number of the printer. The number can be written with any ASCII character between hex 20 and hex 7E. LED Panel: The Asset Number cannot be set via menu instead you need to use the WebPanel
GrSpeed	GrSpeed=Normal <u>GrSpeed=High</u>	This parameter allows improved Graphic Speed independently to the driver. It affects only the print speed of graphic printouts at 180 x 180 dpi.
Jobcntl	Jobcntl=On <u>Jobcntl=Off</u>	This parameter activates the printer language PJP (Printer Job Language) in Connection with the internal Ethernet interface (ETH-INT) or the external TallyCom III interface (ETH-EXT).
UltraDr	<u>UltraDr=on</u> UltraDr=off	Ultra Draft=on, speeds up 17.1 and 20 cpi. Precondition is HS-Draft needs to be activated

5.5 Display messages

If the printer detects an internal fault or user error or if it expects you to do something, a message will appear in the LC display (LED's display message reference below table 5.6.1). It also displays the status during an operation (e.g. **Initializing**). Below you will find a list of messages with brief descriptions of each message.

5.5.1 Messages LED Panel

LED Messages Error/Power ON	Online	Tractor	Speed	Pap.Out	Power/Err.
Hardware Alarm	blink	blink	blink	blink	blink
Switch Paper lever (interm beep)	Off	normal	normal	blink	blink
Paper Width Error	blink	off	blink	blink	blink
EEPROM Error	blink	blink	off	blink	blink
Serial Interface Error	blink	blink	blink	off	blink
“Printhead Hot” Message	blink	off	off	blink	blink
“Check Ribbon” Message	blink	off	off	off	blink
Serial Boot Mode	on	on	off	on	Off
Parallel Boot Mode	on	off	off	on	off
RAM Error	off	on	on	on	off
Missing FPGA	off	on	on	on	on
Monitor Mode for ROM Debugger	on	on	on	off	off
Wrong Header (temporary)	on	off	off	off	off
Sensor Controller (ST8) Error	off	off	on	on	off
Firmware Download Is Running	One lit LED is moving around in a circle, the others are off				

5.5.2 Messages LCD Panel

LCD Messages	Meaning
Eject error	The printer cannot eject the paper/advance it to park position.
Hardware Alarm	Internal hardware error, contact your dealer or service technician.
Head hot	The print head is too hot. The printer will reduce its print speed.
Initializing	This message appears during the printer's initializing phase after switching on the printer.
Load error	The printer fails to load the paper.
Loading default	Factory defined parameters will be reloaded in all available menus after switching on the printer.
Load paper from	The printer has detected paper end during operation/printer was switched on with no paper loaded.
Parity error	A parity error during data transmission is indicated.
Park position	Printer was switched on with no paper loaded.
Press any key	The user is requested to press any key.
Selftest	After power-on, the printer executes a short hardware self-test.
Tear Paper off	The user is requested to tear off paper which has been advanced to the tear.
Switch Paper Lever	Choose correct paper path. Turn paper lever

6 Web Panel and Internal Ethernet Interface

6.1 Summary

6.1.1 Introduction

It is assumed you have the following:

- ◆ A working knowledge of your network system and related utilities.
- ◆ Access to the supervisor or administrator account as a network administrator.

6.1.2 Supported Environments

The built-in network interface supports the following platforms and protocols:

- ◆ Microsoft® Windows® NT 4.0, 2000, XP,7,8, Server 2003/2008/2012
- ◆ Linux – Red Hat®, SuSE®
- ◆ Unix® – Sun Solaris®, HP-UX®, IBM AIX®
- ◆ TCP/IP, HTTP, LPR/LPD

6.1.3 Network Interface and Cabling

The printer requires:

- ◆ Ethernet 10Base-TX or 100Base-TX interface.
- ◆ Category 5e or 6 Ethernet cable with RJ-45 socket connectors.

6.1.4 Connecting the Printer

Connect the Ethernet cable to the network interface port RJ-45 connector on the rear center of the printer.

6.1.5 Network Interface Status

There are two status lights (LEDs) next to the RJ-45 connector on the rear panel.

- ◆ Right green light (Link Status) is solid: This shows the printer is connected to the network.
- ◆ Right green light is blinking: Shows network activity.
- ◆ Left yellow light (Duplex Status) is solid: Shows network interface is in full duplex mode.



Unless the link status light is green, the printer will not be able to connect to the Network.

6.2 IP Configuration

6.2.1 Network IP Configuration

The network interface of the printer requires an IP address.

There are several ways to assign an IP address to the printer:

- ◆ DHCP (A Dynamic Host Configuration Protocol server assigned IP address.)
- ◆ Static (An IP address obtained from your network administrator added to the printer manually.)
- ◆ BOOTP (Bootstrap Protocol server assigned IP address.)

6.2.2 Assigning the IP Address

If the printer menu is locked, please see the [4.2.5](#).

1. Automatic DHCP IP address assignment:

- ◆ Press <Setup>, then <Menu>.
- ◆ Press <Next> until the I/O selection appears. Select <I/O>.
- ◆ Press <Next> until the ETH-INT selection appears. Select <ETH-INT>.
- ◆ Press <Next> until the IP Get M selection appears. Select <IP Get M> Select <DHCP>.
- ◆ Verify that your printer was assigned an IP address by printing the “Current Settings” configuration page or in the operator panel menu.



- 1) At power-up, the printer network interface broadcasts a DHCP request for an IP address. If a DHCP server is present, the request will be processed, and an IP address will be returned to the printer network interface. Upon receipt of the IP address, the printer accepts and uses this new IP address (and subnet mask, and default gateway, if any).
- 2) Once an IP address has been assigned, the printer network interface will no longer broadcast DHCP requests. The printer will broadcast a DHCP request each time you turn on the printer.
- 3) The DHCP server may grant a temporary IP address, called a temporary lease or temporary reservation, which expires later, or may grant a permanent or unlimited time lease or reservation, which does not expire.
- 4) Devices such as the printer that are granted a temporary lease will be notified before the lease expires and asked if they would like to extend the lease. The printer network interface will continue extending its lease indefinitely (unless prohibited by your DHCP server configuration), and thus maintain a consistent IP address.
- 5) If the printer is not turned on or is not connected to the network when the DHCP server is sending requests to extend the lease, the lease will not be extended. The DHCP server will cancel the lease and may assign the IP address to another device. Therefore, it is highly recommended to explicitly specify the printer lease as permanent or unlimited in your DHCP server configuration.

2. Static assignment using the operator panel:

- ◆ Press < Setup >, then < Menu >.
- ◆ Press < Next > until the I/O selection appears. Select < I/O >.
- ◆ Press < Next > until the ETH-INT selection appears. Select < ETH-INT >, then < IP Addr >
- ◆ Enter the value for Octet 1 by pressing < OCTET 1 >. Use the forward and backward arrows to increment/decrement the number. When finished with each entry press < Set > which will set the currently displayed value. To exit out without changing the value press < Exit >. Enter the Octet 2 value in the same way, pressing < OCTET 2 >. To get to Octet 3 and Octet 4, select < Next > and then select <OCTET 3> and < OCTET 4 >.
- ◆ Enter the default Gateway and Subnet mask in the same way. < Gateway > is available from the screen you are returned to. Press < Next > to select < Subnet >.
- ◆ Enter the IP address get method under the selection <IP Get M>. Select <Static>.

3. BOOTP IP address assignment:

- ◆ Press <Setup>, then <Menu>.
- ◆ Press <Next> until the I/O selection appears. Select <I/O>.
- ◆ Press <Next> until the ETH-INT selection appears. Select <ETH-INT>.
- ◆ Press <Next> until the IP Get M selection appears. Select <IP Get M> Select <BOOTP>
- ◆ Obtain the Ethernet MAC address by printing the “Current Settings” configuration page, Turn off printer.
- ◆ Configure your BOOTP server with desired IP address and MAC address.
- ◆ Turn on printer.
- ◆ Verify that the printer network interface received an IP address by printing the “Current Settings” configuration page or in the operator panel menu.

6.3 WebPanel

6.3.1 Introduction

WebPanel is an intuitive browser interface that allows you to remotely manage your network attached printer. From WebPanel, you can do virtually everything you can do from the printer's control panel.

In addition, WebPanel provides full access to all of the TallyCom networking features. Before using WebPanel, you must configure your printer with an IP address, using one of the three methods discussed in the Assigning the IP Address section above.



The screenshots that are used in this document to demonstrate the functionality may vary depending on the printer model.

6.3.2 Web Browser

WebPanel is accessed from the printer through a web browser, i.e. Internet Explorer, Firefox, etc. The browser needs to be configured with cache and history empty, and the browser set up to check for new pages every time, to insure that connections to WebPanel will produce the latest data.

WebPanel does not work through a proxy server. Therefore, the web browser must be setup to NOT use the Proxy Server for local IP addresses.

Disclaimer: Dascom WebPanel runs in conjunction with third party software, notably web browsers, which are designed to run independently of the Dascom software. Dascom cannot control the third party output or how it behaves from release to release. The above browser versions have been tested with WebPanel and while there is full functionality, there will undoubtedly be visual differences and anomalies between products and versions with which Dascom has no control.

Tally Dascom 2610

6.3.3 Access to WebPanel

Once an IP address has been set up, you can access WebPanel by typing the printer's IP address into your browser address box.

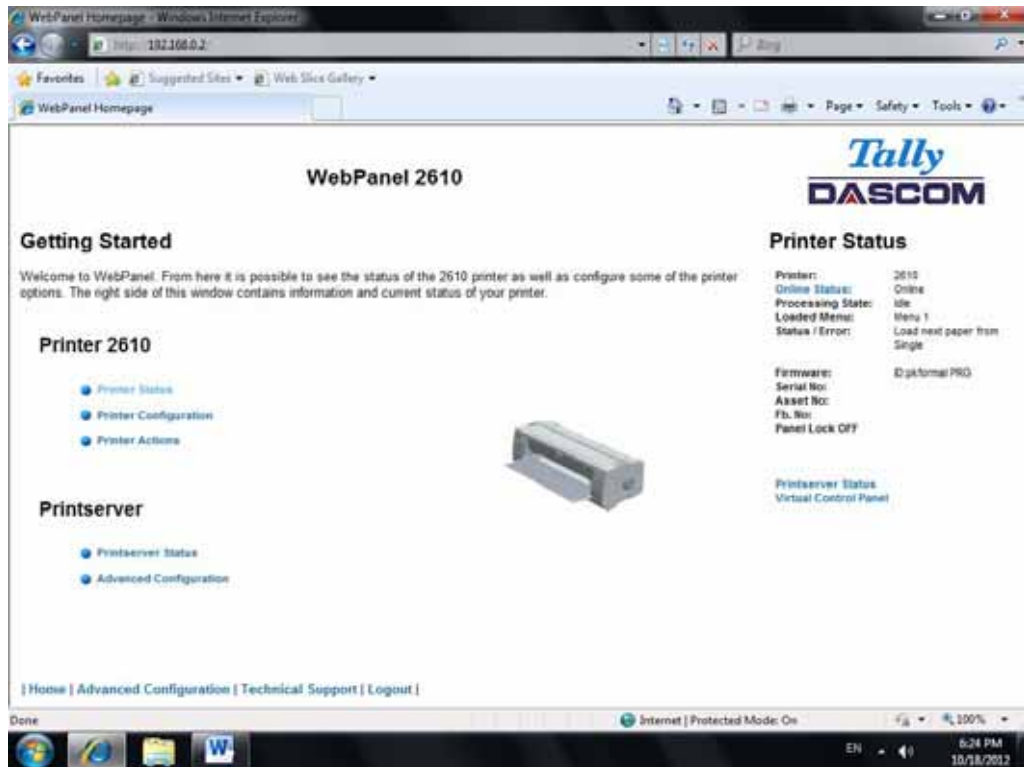

The current status of your printer is displayed on the right hand side of the screen. This is refreshed every 20 seconds, whenever you refresh the page or click Printer Status. The left side allows you to query the printer, configure it and access network options.



If you try to access the printer after power on the printer it may last up to one minute until the printer is visible in the network.

6.3.4 Printer Status

Selecting this option refreshes the status display. Displayed on this page are:

- ◆ Processing state
- ◆ Loaded menu
- ◆ Error state
- ◆ Firmware level
- ◆ Serial number
- ◆ Asset number
- ◆ Panel lock status

Options to change the Online / Offline state, network configuration and the virtual control panel for your printer are all accessed from this page.

Tally Dascom 2610

6.3.5 Printer Configuration

Selecting this option allows you to configure specific parameters in the printer. When one of these menu options is selected, a new page will load showing the options which can be viewed or modified.

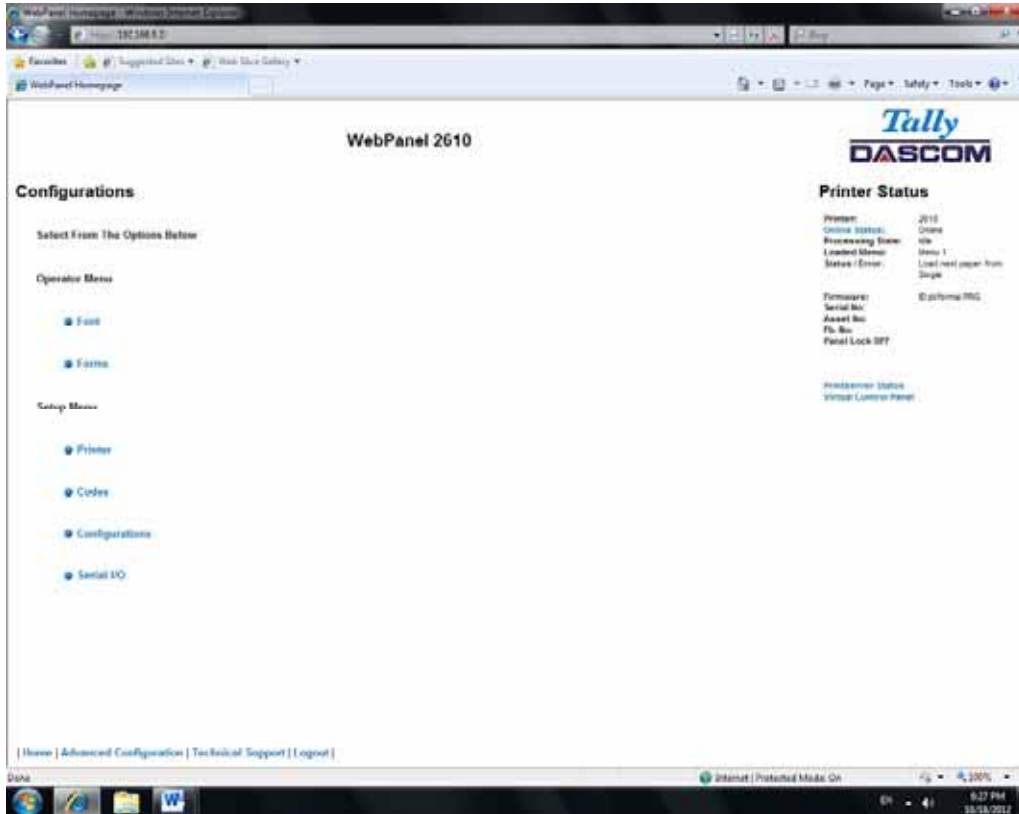

Tally Dascom 2610

Example 1

Changing the dropdown menu option.

In this example, we are modifying the selected font to a different font. Select “Font”. A new page appears.

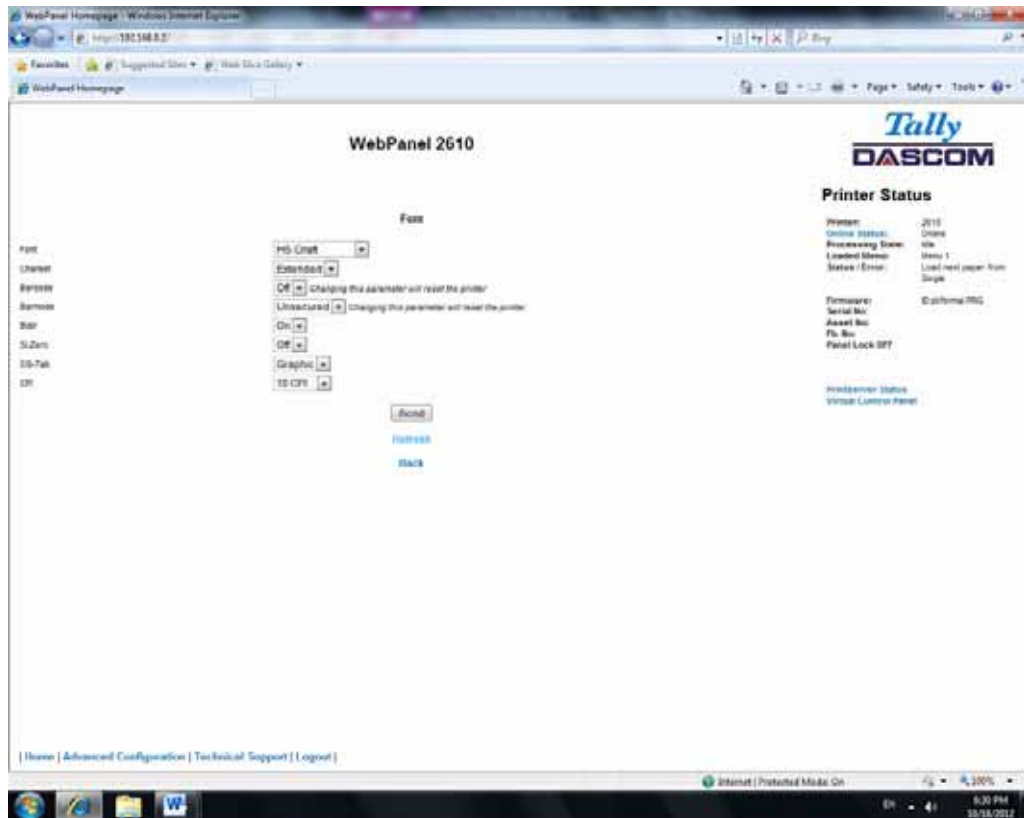

Select the Font dropdown menu and choose the new font. Select “Send”.



- 1) Changes are not applied until “Send” is selected.
- 2) To reset the changed value to the prior value, select “Refresh” instead of “Send”.
- 3) To return to the prior page without applying the change, select “Back”.

Tally Dascom 2610

Example 2

Changing an entered value menu option.

In this example, we are modifying the selected form length to a different form length. Select “Forms”. A new page appears:

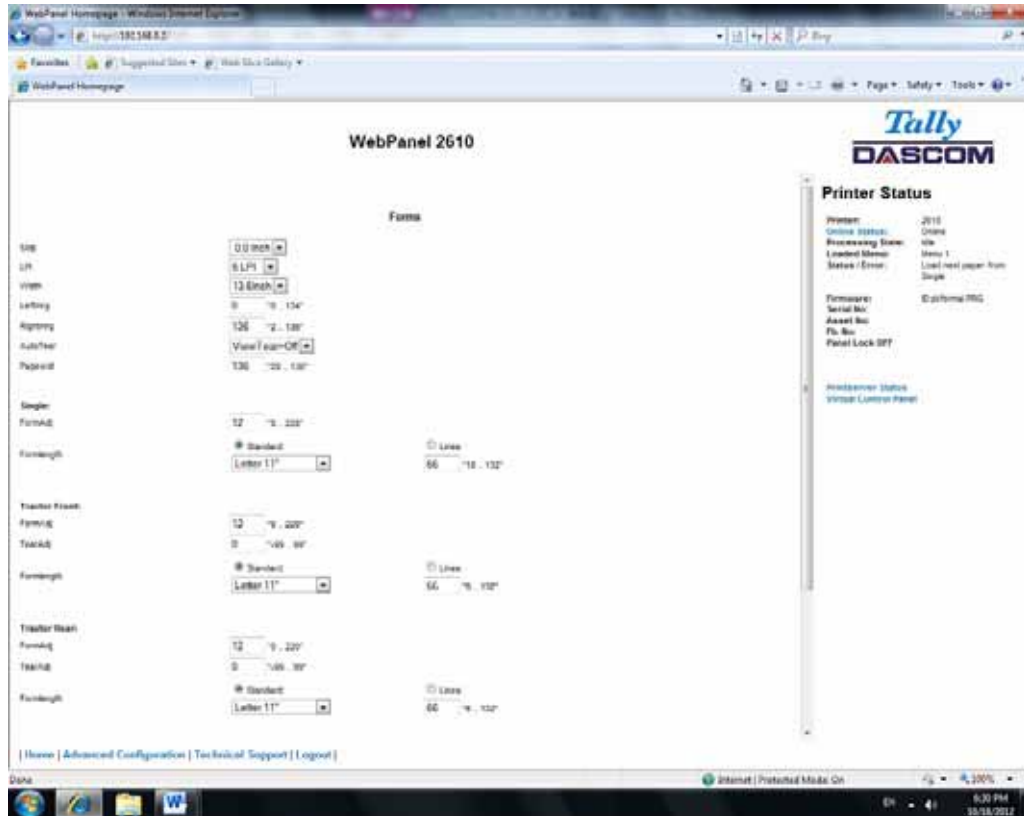

Select the Form Length field by highlighting the contents of the box and enter the new form length.

The acceptable parameters are listed to the right of the field. Select “Send”.



- 1) Changes are not applied until “Send” is selected.
- 2) If the entered value is out of range of the acceptable parameters, the previous value will be re-instated.
- 3) To reset the changed value to the prior value, select “Refresh” instead of “Send”. To return to the prior page without applying the change, select “Back”.
- 4) The default name is “conf.cfg”, but it can be renamed. Saving the file to disk. This will allow it to be transferred to other printers using the “Send Configuration To Printer” option on the actions web page.

Tally Dascom 2610

6.3.6 Printer Actions

Selecting the Printer Actions link will produce a page with a list of actions that can be performed on the printer.

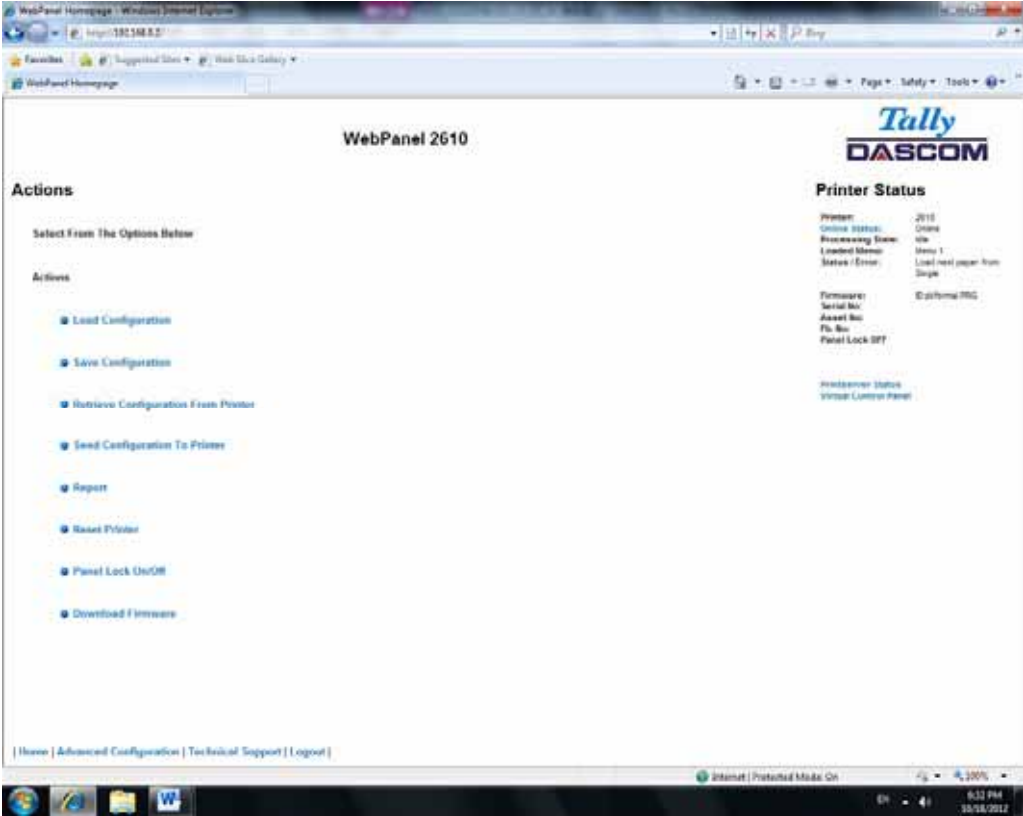

Tally Dascom 2610

6.3.7 Load Configuration

Loads the settings stored in a menu into the printer as the current settings. When the Load Configuration link is selected, the following page will be displayed:

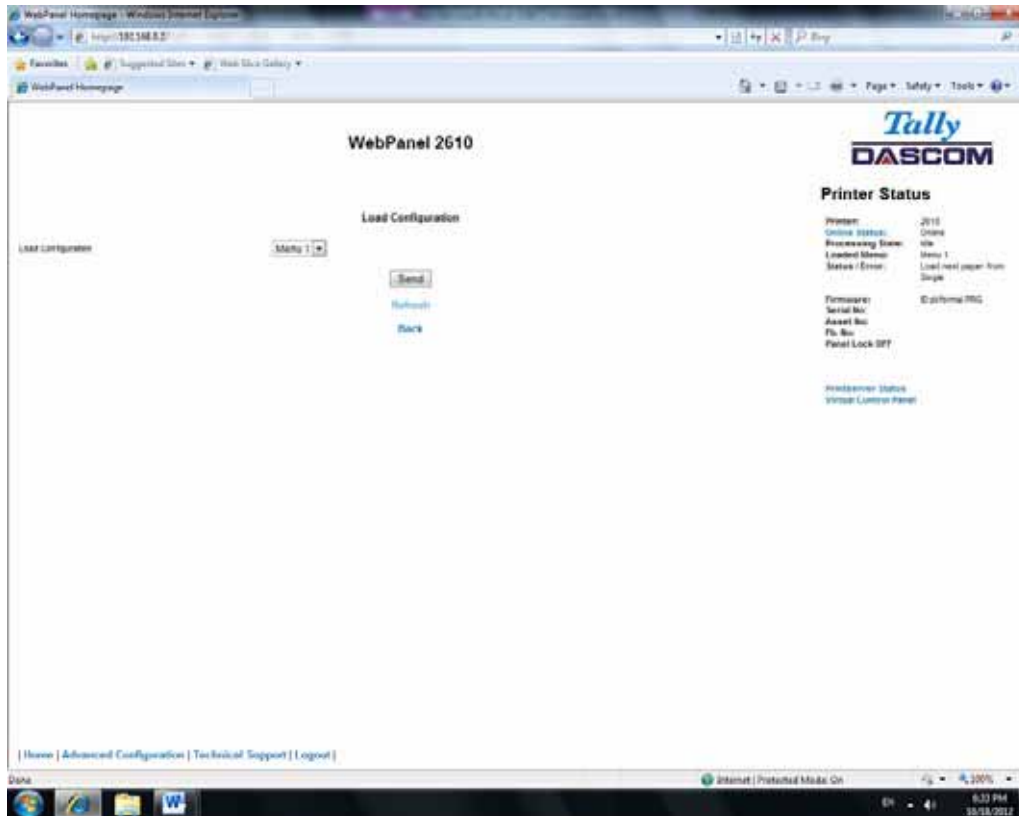

Select a menu and confirm your selection by selecting the Send button.

Tally Dascom 2610

6.3.8 Save Configuration

You can save selected printer settings in up to 5 independent menus. When the Save Configuration like is selected, the following page will be displayed:

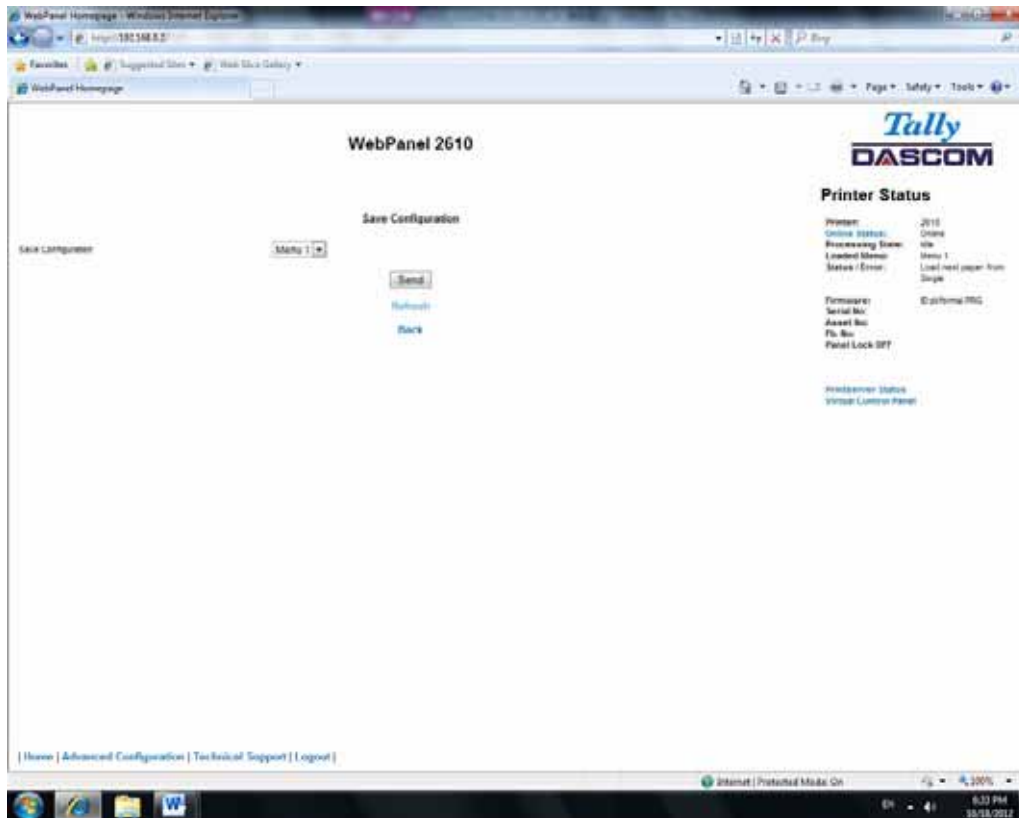

Select a menu. Select send.

6.3.9 Retrieve Configuration From Printer

Selecting this option will save all the printer settings of all menus in a file. Uploading this file to other printers will clone the printer menu settings to the other printer. When this option is selected, the following will appear (note that the actual image will be browser specific):

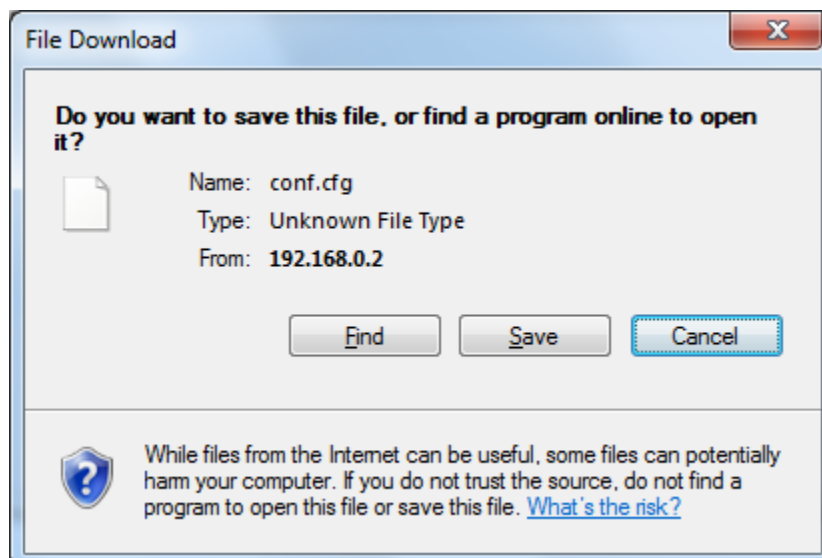

Tally Dascom 2610

6.3.10 Send Configuration to Printer

Selecting this option will upload a Configuration File of another printer (see “Retrieve Configuration From Printer”). The complete configuration of this source printer will be transferred to your printer.

To upload the configuration file, first click “Send Configuration To Printer”. The following page will be displayed:

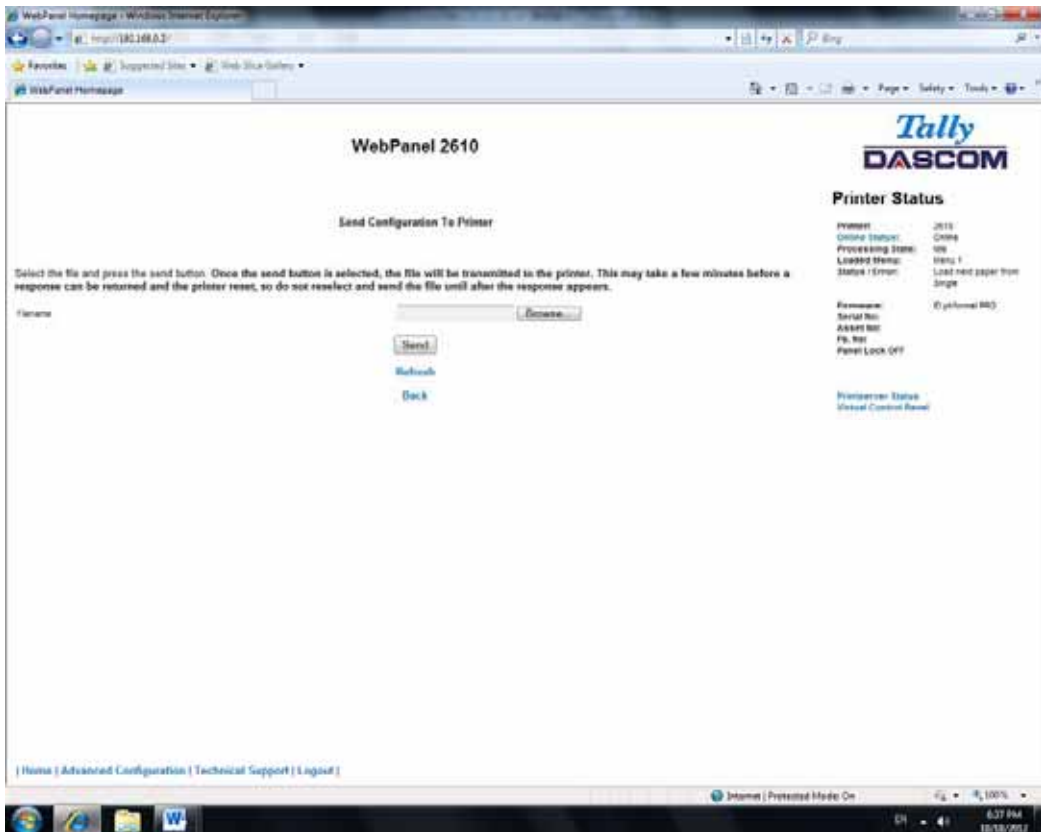

Tally Dascom 2610

Use the “Browse” button to find the file to upload. Once the file is selected, click on the “Send” button. It is important to note the warning on this page. There is some delay while the file is transmitted so it is important not to resend or click on the “Send” button until the process is complete.

If the process is successful, the printer will reboot and the following page will be displayed:

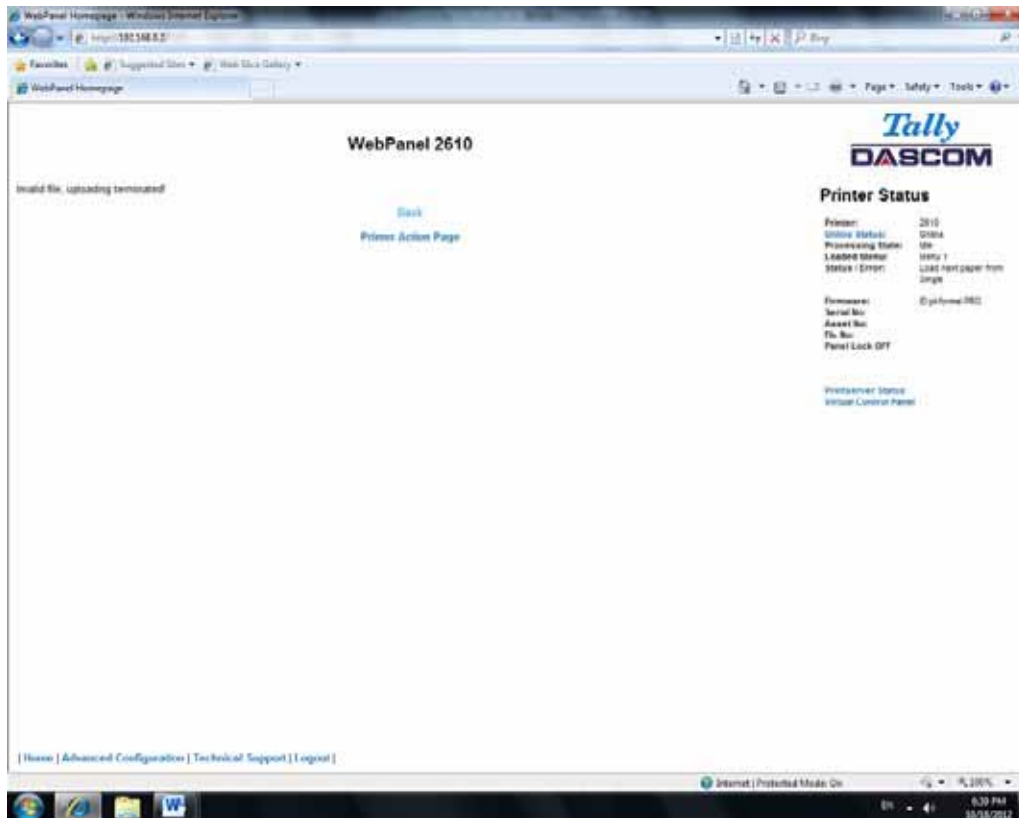

Since the printer will reboot with successful completion of this action, the user will have to reconnect to the printer through the browser.

Tally Dascom 2610

6.3.11 Report

Selecting the report link will open up a separate browser window and a report of the printer settings will appear. This functionality is the same as pressing the “Print” option on the control panel of the printer.

6.3.12 Reset Printer

This link does a hard reset of the printer, similar to cycling power. There is no user feedback as to success since the printer is rebooting. Since the printer will reboot with successful completion of this action, the user will have to reconnect to the printer through the browser.

6.3.13 Panel Lock On/Off

This link toggles the panel lock feature of the printer. This option affects the physical control panel on the printer as well as the virtual panel in WebPanel. The state of the option is displayed in the printer status page on the right of the display.

6.3.14 Download Firmware

Through this link it is possible to download firmware updates to the printer. When this link is selected, the follow page will appear:

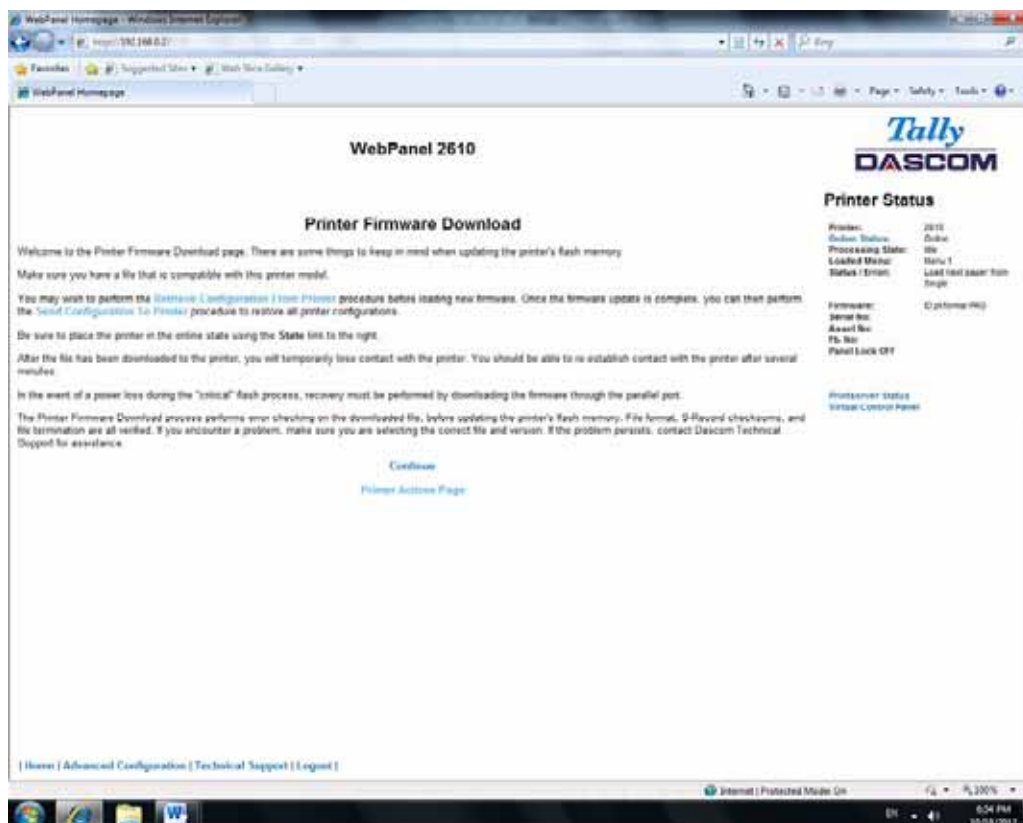

Tally Dascom 2610

After following the directions on this page, select the “Continue” link and the following page is displayed:

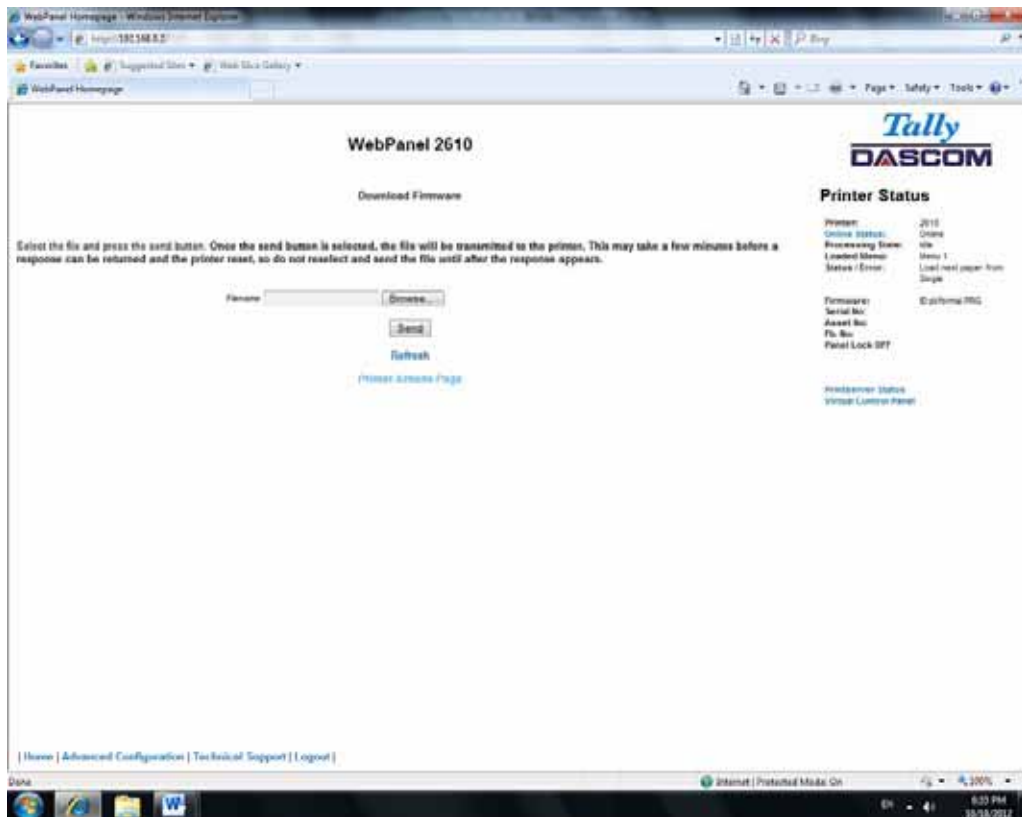

Using the “Browse” button, find the firmware file to download. Once the file is selected, click on the “Send” button. It is important to note the warning on this page. There will be some delay while the file is transmitted so it is important NOT to resend or click on the “Send” button until the process is complete.

Tally Dascom 2610

If the process is successful, the printer will reboot and the following page will be displayed:

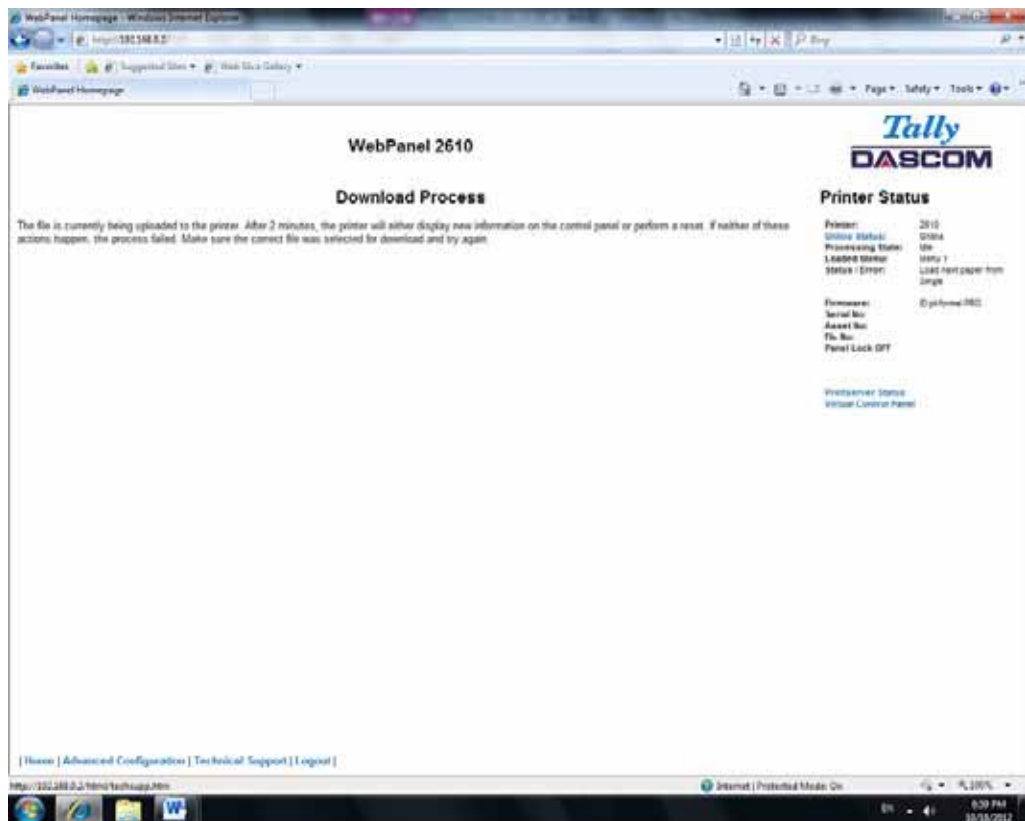

Since the printer will reboot with successful completion of this action, the user will have to reconnect to the printer through the browser.

Tally Dascom 2610

6.3.15 TallyCom Status

Selecting this link will replace the information in the Printer Status area with networking information on the printer.

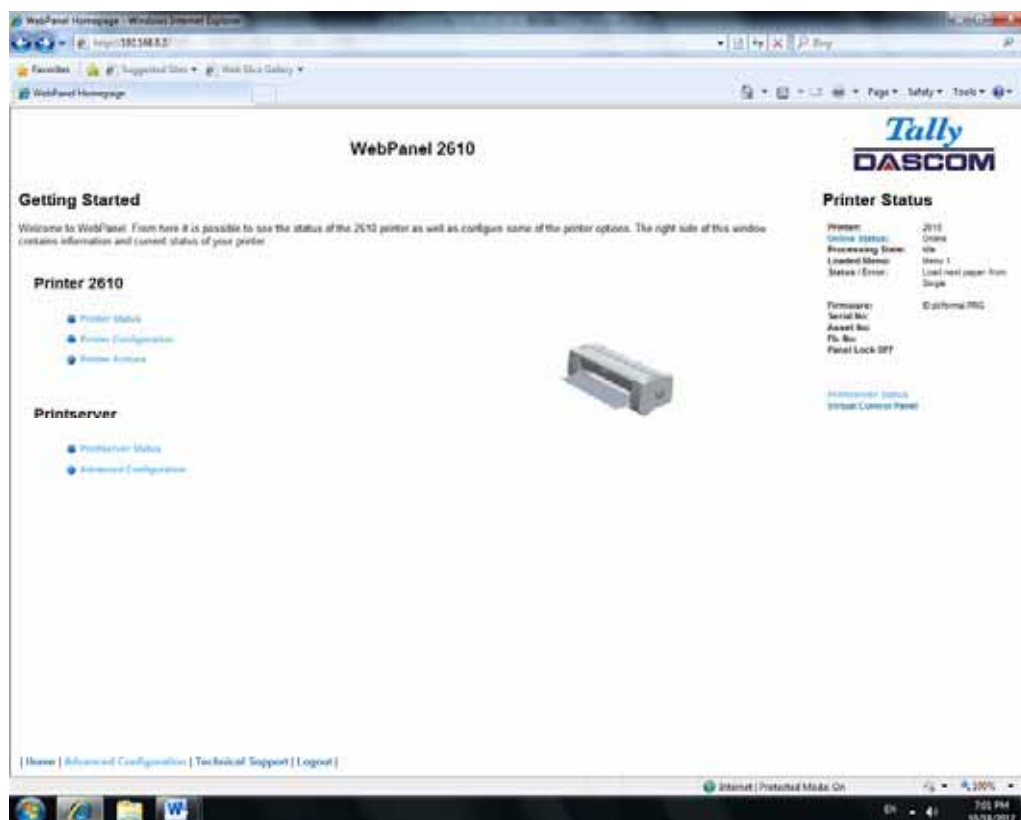

The Name, Contact and Location information is set up from the General link within the Advanced Configuration page.

6.3.16 Advanced Configuration

The Advanced Configuration page allows the user to set up and modify network connectivity information as well as setting up the password, email notification and logical printers. From this page it is also possible to Logout of TallyCom and restart TallyCom. The Administration page looks like this:

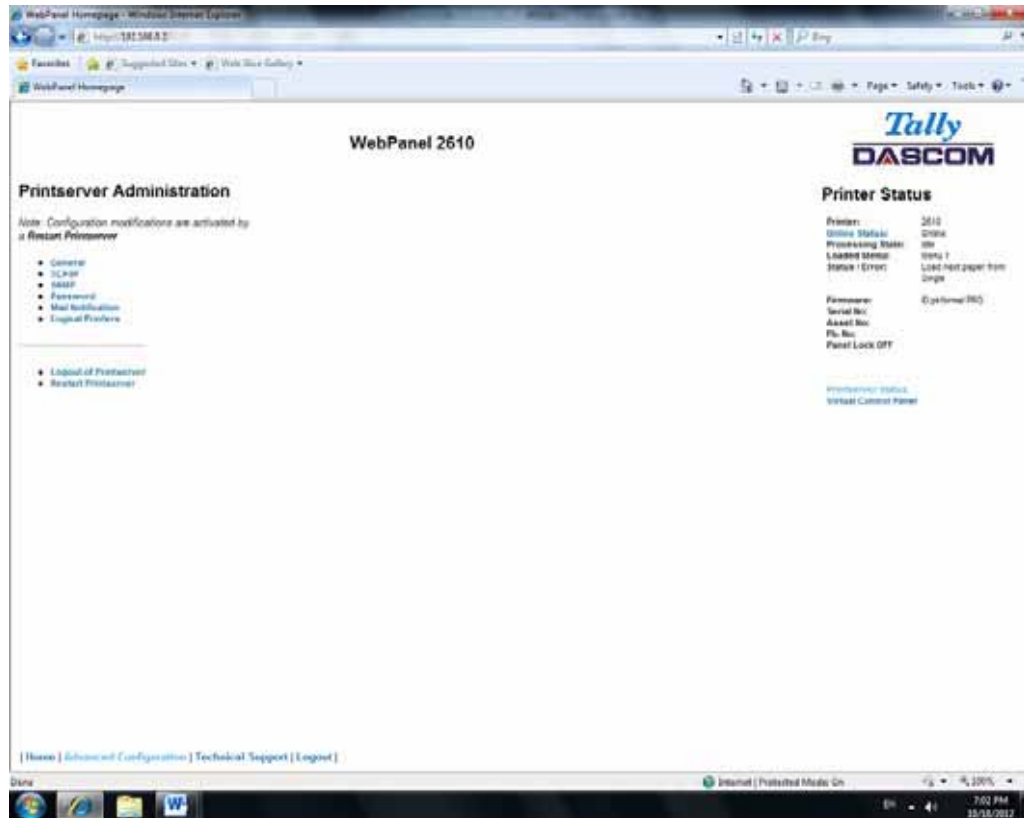

Tally Dascom 2610

6.3.17 General

The General page sets up the timers and the labels for name, contact and location of the printer.

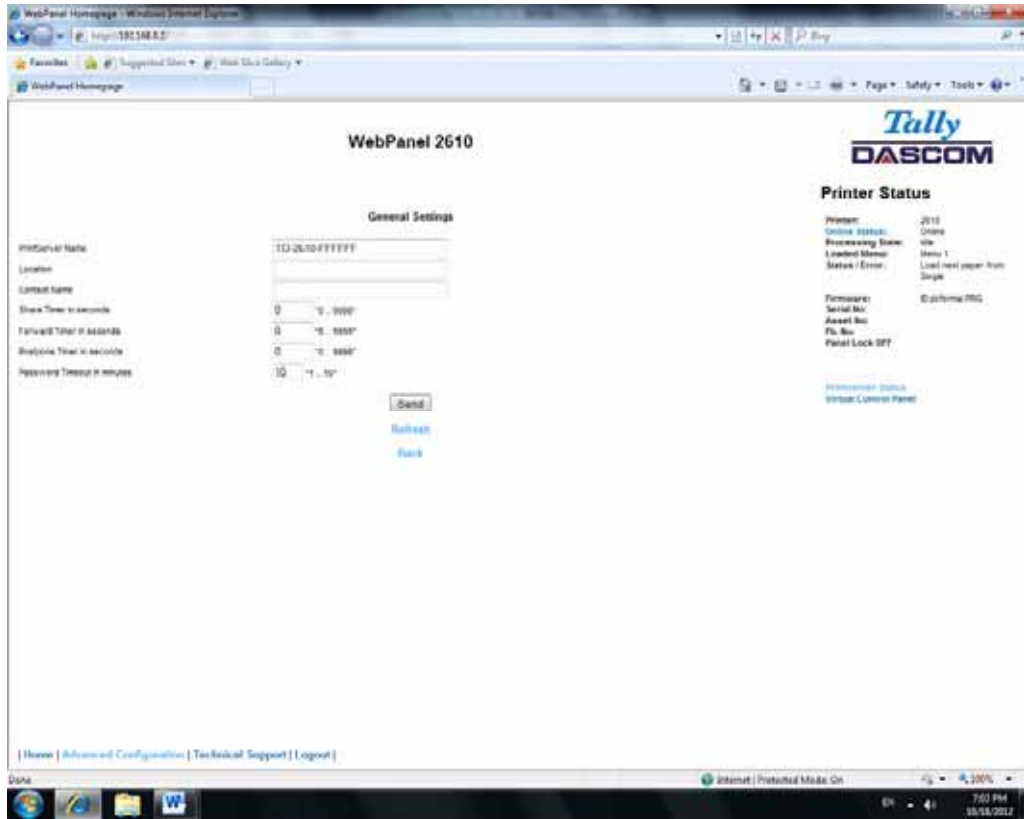

The Print Server Name is by default and can be changed accordingly. This name used for entering into Name Server (DNS/DHCP).

Tally Dascom 2610

6.3.18 TCP/IP

The TCP/IP Page allows the user to modify the existing TCP/IP information for the printer. After changing the particular parameters, it is necessary to restart TallyCom from the Advanced Configuration page. If the IP Address is changed and the Send button selected you will disconnect from the current session and will need to reconnect at the new IP Address.

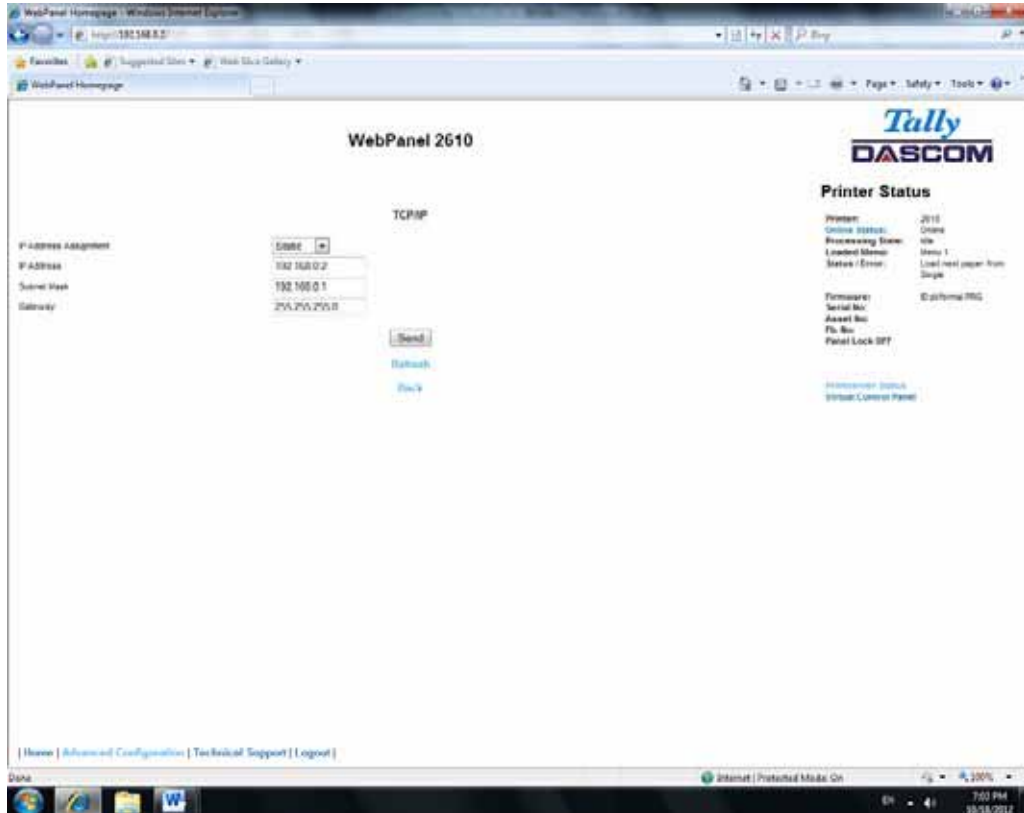

Tally Dascom 2610

6.3.19 SNMP

The SNMP page allows the user to set the Community Name and the Access. The page looks like this:

