

**Essentials Wireless Full Featured  
Compact Keyboard  
User's Guide**

**Federal Communications Commission Radio(FCC)  
Statement**

This equipment has been tested and found to comply with the limits for a Class B digital device, pursuant to part 15 of the FCC Rules. These limits are designed to provide reasonable protection against harmful interference in a residential installation. This equipment generates, uses and can radiate radio frequency energy and, if not installed and used in accordance with the instructions, may cause harmful interference to radio communications. However, there is no guarantee that interference will not occur in a particular installation. If this equipment does cause harmful interference to radio or television reception, which can be determined by turning the equipment off and on, the user is encouraged to try to correct the interference by one or more of the following measures:

- Reorient or relocate the receiving antenna.
- Increase the separation between the equipment and receiver.

- Connect the equipment into an outlet on a circuit different from that to which the receiver is connected.
- Consult the dealer or an experienced radio/TV technician for help.

Operation is subject to the following two conditions:

- (1) this device may not cause harmful interference, and
- (2) this device must accept any interference received, including interference that may cause undesired operation.

### **Caution!**

The manufacturer is not responsible for any radio or TV interference caused by unauthorized modifications to this equipment. Such modifications could void the user authority to

operate the equipment.

### **R & TTE Compliance Statement**

This equipment complies with all the requirements of the DIRECTIVE 1999/5/EC OF THE EUROPEAN PARLIAMENT AND THE COUNCIL OF 9 March 1999 on radio equipment and telecommunication terminal equipment and the mutual recognition of their conformity (R & TTE).

## 1 Feature

- Transmission mode: RF 2.4G
- Frequency: 2402~2480MHz
- RF channel quantity: 79
- Bandwidth of Channel: 1MHz
- Data send timing: <500us
- Keyboard power: 2 × AAA batteries
- Receiver power: 5V
- Modulation mode: GFSK
- Effective distance: 10m
- Number of keys: 96 keys
- Low battery indicating voltage: 2.0V@5%
- Operational Temperature: +5 ~ +40°C

## 2 System Requirements

- Microsoft Windows 98/ME/2000/XP/Vista/7 or later version
- An available USB port

## 3 Installation & Use

- Plug the USB receiver into a computer's USB port:

- **Windows 98 SE/ME**

The system finds new device and prompts you to insert the operating system CD-ROM. Follow the instructions on the screen to install the required drivers.

- **Windows 2000/XP/Vista/7**

The operating system identifies the receiver as a "USB Human Interface Device" and begins installation automatically. When completed, the system will prompt that "Your new hardware is installed and ready to use."

- Remove the keyboard battery compartment cover.

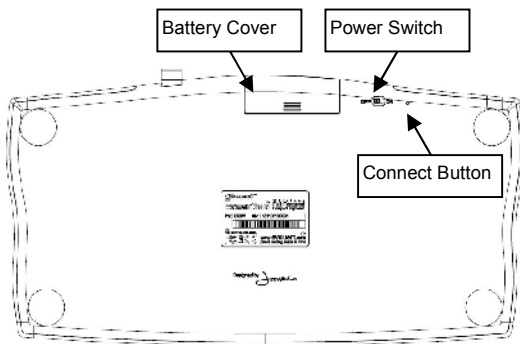

- Install batteries with the positive (+) & negative (-) in the correct direction indicated by the AAA battery compartment label.
- Replace the battery compartment cover.
- Switch on the Keyboard.
- Before first time of use, you need to pair the keyboard to the receiver as below:  
Use a paperclip, pen or pointed object to press into the reset pin hole on the back of the keyboard, the LowBatt Led will twinkle. Plug the receiver into the PC's USB port, the LED will be off if it is successfully paired.
- Keyboard LED function



Low Battery----This LED will be lit if the battery power is low, you should replace the battery right now.