

# JME-8279R user guide

## 1. Keyboard Appearance draw

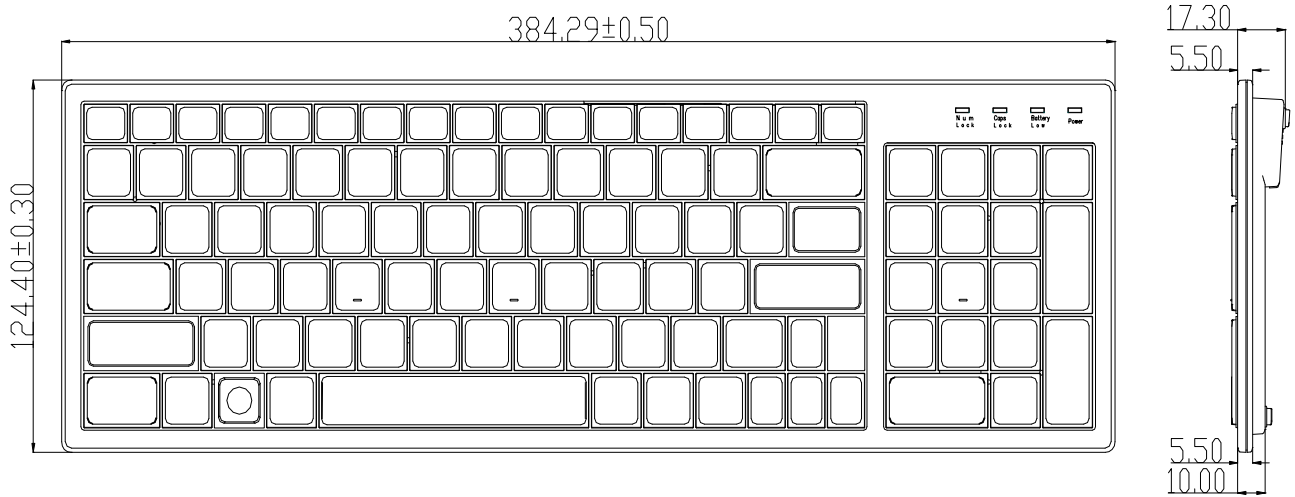

## 2. Front view

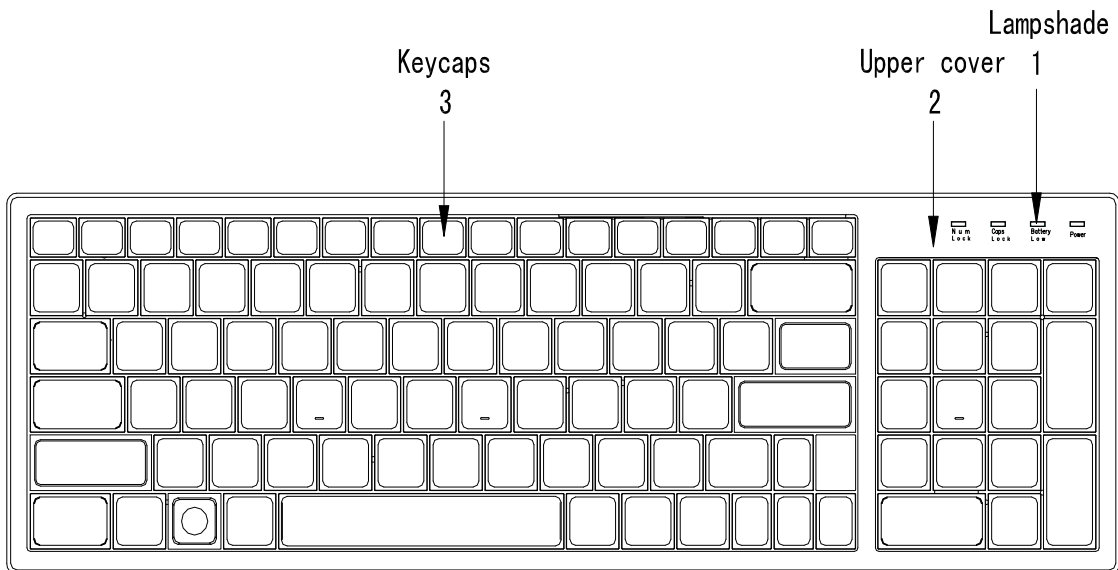

### 3. Back view

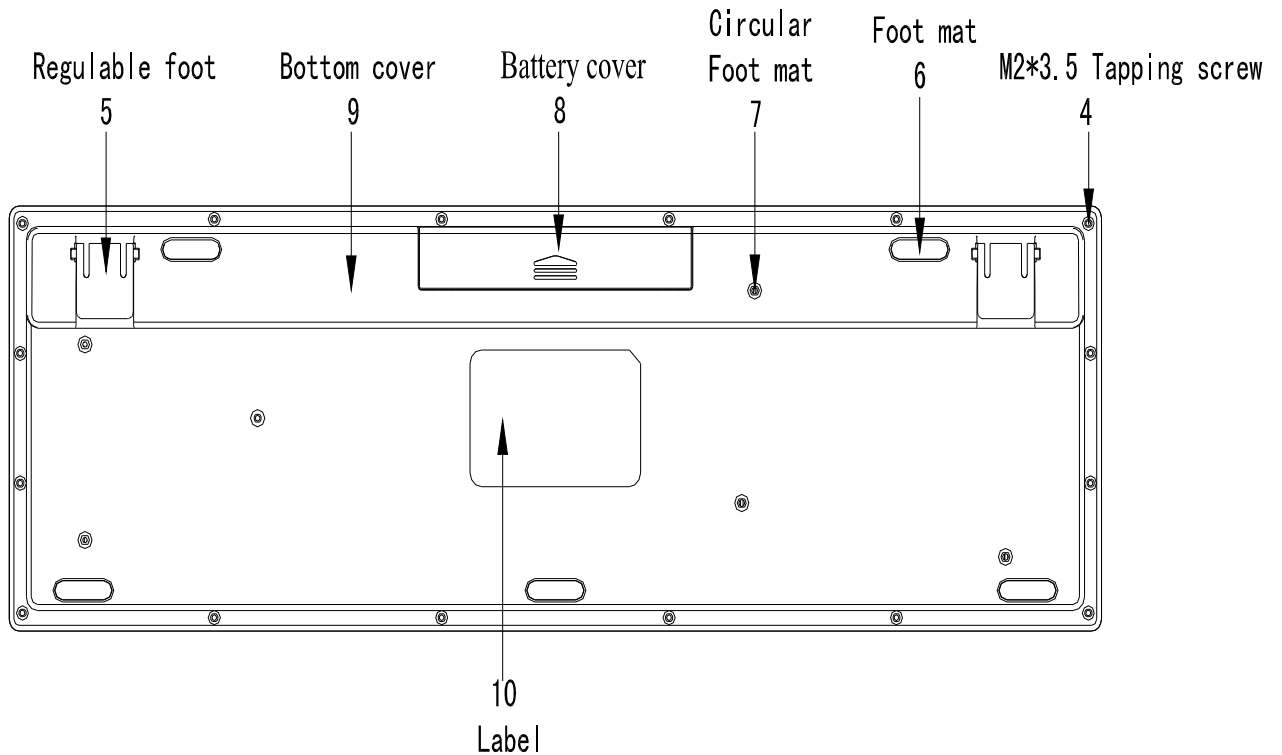

### 4. Feature

- 4.1 Transmission mode: RF
- 4.2 Frequency: 2410~2473MHz
- 4.3 RFchannel quantity: 64
- 4.4 Center of Channel: 2410/2411/242...2471/2472/2473MHz
- 4.5 Width of Channel: 1MHz
- 4.6 Hopping Technology : Digital FHSS (Frequency Hopping Spread Spectrum)
- 4.7 Data Send timing: <500us
- 4.8 Power: 2pcs \*AAA alkaline batteries (1.5V)
- 4.9 Modulate mode: MSK
- 4.10 Effective distance: 12m
- 4.11 Quantity of connection ID: 24Bits (8,388,608 ID can be used)
- 4.12 Number of keys: 99
- 4.13 Operating temperature: +5°C~+40°C

## 5. Use guide

### 5.1 Battery Installation

a. Unlock the battery cover

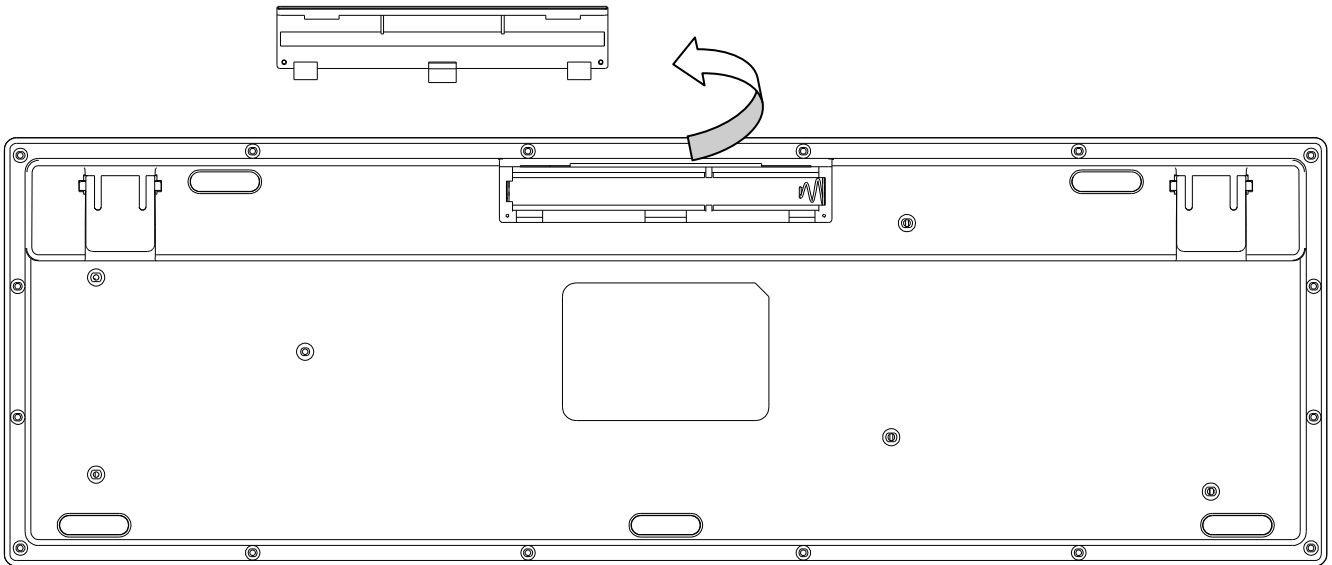

b. Install the battery and match the code

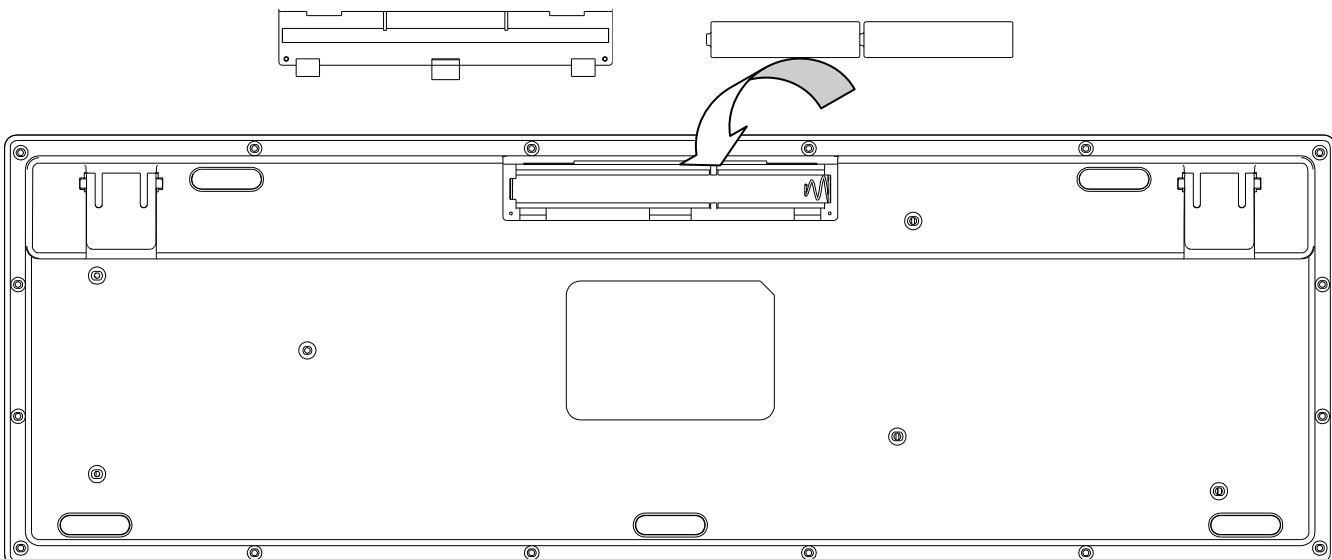

Caution:

Risk of explosion if battery is replaced by an incorrect type  
Dispose of used batteries according to the instructions

Need to check and match the code for the first of time of usage only, Please match the code as below :

1. First, confirm the receiver has been connected to the computer.
2. With the keyboard close to the receiver within 50cm, hold down “ESC” key and inclose two pieces of batteries, when the receiver’s led blinks 4 times, the keyboard is ready to be used

## **6.FCC Statement**

This equipment has been tested and found to comply with the limits for a Class B digital device, pursuant to part 15 of the FCC rules. These limits are designed to provide reasonable protection against harmful interference in a residential installation. This equipment generates, uses and can radiate radio frequency energy and, if not installed and used in accordance with the instructions, may cause harmful interference to radio communications. However, there is no guarantee that interference will not occur in a particular installation. If this equipment does cause harmful interference

to radio or television reception, which can be determined by turning the equipment off and on, the user is encouraged to try to correct the interference by one or more of the following measures:

- Reorient or relocate the receiving antenna.
- Increase the separation between the equipment and receiver.
- Connect the equipment into an outlet on a circuit different from that to which the receiver is connected.
- Consult the dealer or an experienced radio/TV technician for help.

To assure continued compliance, any changes or modifications not expressly approved by the party responsible for compliance could void the user's authority to operate this equipment. (Example- use only shielded interface cables when connecting to computer or peripheral devices).

This device complies with Part 15 of FCC RF Rules. Operation is subject to the following two conditions:

- 1) This device may not cause interference and
- 2) This device must accept any interference, including interference that may cause undesired operation of the device.

### **Caution!**

The manufacturer is not responsible for any radio or TV interference caused by unauthorized modifications to this equipment. Such modifications could void the user authority to operate the equipment.