

7.5 METRIC TON



**JOHN DEERE**

**C**

**EXCAVATOR**

**75C**



# Specifications

DEERE

## Engine

### 75C

Type	Isuzu CC-4JG1 – naturally aspirated direct-injection diesel; certified to EPA Tier 2 emissions
Net Peak Power (ISO9249)	54 hp (40 kW) @ 2,100 rpm
Net Peak Torque (ISO9249)	142 lb.-ft. (192 Nm) @ 1,700 rpm
Cylinders	4
Displacement	187 cu. in. (3.059 L)
Cooling Fan	suction type
Electrical System	24 volt with 30-amp alternator
Batteries (two 12 volt)	reserve capacity: 100 min.
Off-Level Capacity	70% (35 deg.)

## Hydraulic System

Main Pumps	two variable-displacement axial-piston
Maximum Flow	2 x 18.3 gpm (2 x 69.3 L/min.)
Swing Gear Pump	13.9 gpm (52.5 L/min.)
Pilot Pump	one gear
Maximum Flow	5.9 gpm (22.5 L/min.)
Pressure Setting	570 psi (3930 kPa)
Dozer Blade Pump	one gear
System Operating Pressure	
Implement Circuits	3,770 psi (25 988 kPa)
Travel Circuits	4,550 psi (31 380 kPa)
Swing Circuits	3,270 psi (22 546 kPa)
Blade Circuit	3,770 psi (25 988 kPa)
Oil Filtration	one 10-micron full-flow return filter with by-pass / one pilot oil filter / one suction filter

## Cylinders

	Bore	Rod Diameter	Stroke
Boom (1)	4.5 in. (115 mm)	2.6 in. (65 mm)	34.8 in. (885 mm)
Arm (1)	3.7 in. (95 mm)	2.4 in. (60 mm)	35.4 in. (900 mm)
Bucket (1)	3.3 in. (85 mm)	2.2 in. (55 mm)	28.7 in. (730 mm)

## Swing Mechanism

Swing Speed	0–11 rpm
Swing Torque	10,200 lb.-ft. (13 840 Nm)

## Undercarriage

Carrier Rollers (per side)	1
Track Rollers (per side)	5
Idlers (per side)	1
Shoes, Triple Semi-Grouser (per side)	40
Track Guides	front
Track Adjustment	hydraulic
Travel Speed	
Low	0–2.1 mph (0–3.3 km/h)
High	0–3.1 mph (0–5.0 km/h)
Drawbar Pull	12,350 lb. (5602 kg)

## Ground Pressure Data

75C

### Average Ground Pressure

- 24-in. (600 mm) Triple Semi-Grouser Shoes  
(recommended for general/soft terrain) . . . 3.53 psi (24.34 kPa)
- 18-in. (4450 mm) Rubber Crawler Pads  
(recommended for street use only) . . . . . 4.65 psi (32.06 kPa)

## Capacities (U.S.)

- Fuel Tank. . . . . 31.7 gal. (120 L)
- Cooling System . . . . . 6.1 qt. (5.8 L)
- Engine Lubrication, Including Filter . . . . . 10.5 qt. (9.9 L)
- Hydraulic Tank. . . . . 15.5 gal. (58.7 L)
- Hydraulic System . . . . . 26.4 gal. (100 L)
- Propel Gearbox (each) . . . . . 2.6 qt. (2.5 L)

## SAE Operating Weights

- With Full Fuel Tank; 175-lb. (79 kg) Operator;  
0.36-cu.-yd. (0.28 m<sup>3</sup>), 30-in. (750 mm),  
522-lb. (237 kg) Bucket; 6-ft. 11-in. (2.12 m)  
Arm; 3,042-lb. (1380 kg) Counterweight;  
24-in. (600 mm) Triple Semi-Grouser Shoes;  
and Backfill Blade . . . . . 17,714 lb. (8035 kg)

## Component Weights

- Undercarriage
  - 24-in. (600 mm) Triple Semi-Grouser Shoes . . . 6,481 lb. (2940 kg)
  - 18-in. (450 mm) Rubber Crawler Pads . . . . . 6,261 lb. (2840 kg)
- Standard One-Piece Boom (with boom and  
arm cylinders) . . . . . 1,082 lb. (491 kg)
- Boom Cylinder Only . . . . . 203 lb. (92 kg)
- Arm with Bucket Cylinder and Linkage
  - 5 ft. 4 in. (1.62 m) . . . . . 567 lb. (257 kg)
  - 6 ft. 11 in. (2.12 m) . . . . . 653 lb. (296 kg)
- Counterweight . . . . . 3,042 lb. (1380 kg)
- 0.36-cu.-yd. (0.28 m<sup>3</sup>), 30-in. (750 mm) Bucket . . . 522 lb. (237 kg)

## Operating Information

	<i>Arm Length</i> 5 ft. 4 in. (1.62 m)	<i>Arm Length</i> 6 ft. 11 in. (2.12 m)
Arm Force with 30-in. (750 mm), 0.36-cu.-yd. (0.28 m <sup>3</sup> ), 522-lb. (237 kg) Heavy-Duty Bucket . . . . .	8,425 lb. (37.5 kN)	7,190 lb. (32.0 kN)
Bucket Digging Force with 30-in. (750 mm), 0.36-cu.-yd. (0.28 m <sup>3</sup> ), 522-lb. (237 kg) Heavy-Duty Bucket . . . . .	11,220 lb. (49.9 kN)	11,220 lb. (49.9 kN)
Lifting Capacity Over Front @ Ground Level		
15-ft. (4.57 m) Reach . . . . .	2,988 lb. (1355 kg)	3,335 lb. (1513 kg)
<b>A</b> Maximum Reach . . . . .	21 ft. 1 in. (6.43 m)	22 ft. 8 in. (6.92 m)
<b>A'</b> Maximum Reach @ Ground Level . . . . .	20 ft. 6 in. (6.26 m)	22 ft. 2 in. (6.76 m)
<b>B</b> Maximum Digging Depth . . . . .	13 ft. 6 in. (4.11 m)	15 ft. 1 in. (4.61 m)
<b>B'</b> Maximum Digging Depth @ 8-ft. (2.44 m) Flat Bottom . . . . .	12 ft. 4 in. (3.76 m)	14 ft. 0 in. (4.33 m)
<b>C</b> Maximum Cutting Height . . . . .	23 ft. 8 in. (7.21 m)	25 ft. 0 in. (7.61 m)
<b>D</b> Maximum Dumping Height . . . . .	16 ft. 10 in. (5.12 m)	18 ft. 1 in. (5.51 m)
<b>E</b> Minimum Swing Radius . . . . .	5 ft. 11 in. (1.81 m)	7 ft. 1 in. (2.17 m)
<b>F</b> Maximum Vertical Wall . . . . .	12 ft. 0 in. (3.67 m)	13 ft. 10 in. (4.21 m)
<b>G</b> Tail Swing Radius . . . . .	4 ft. 0 in. (1.21 m)	4 ft. 0 in. (1.21 m)

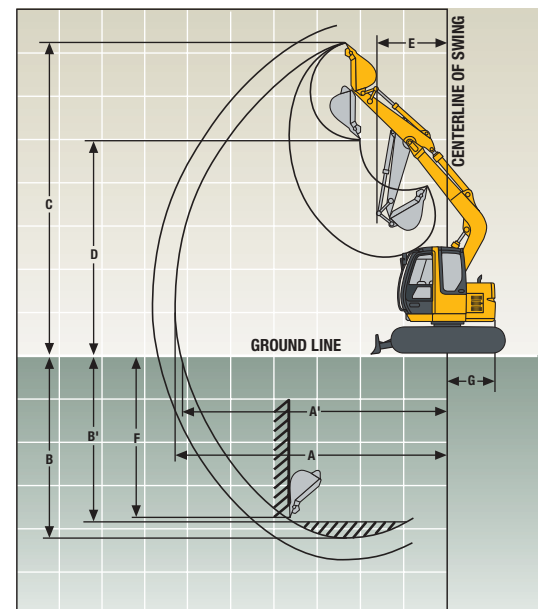

## Dimensions

75C

- A** 5-ft. 4-in. (1.62 m) Arm. . . . . 8 ft. 10 in. (2.69 m)  
 6-ft. 11-in. (2.12 m) Arm. . . . . 9 ft. 3 in. (2.83 m)
- B** 5-ft. 4-in. (1.62 m) Arm. . . . . 19 ft. 3 in. (5.87 m)  
 6-ft. 11-in. (2.12 m) Arm. . . . . 19 ft. 6 in. (5.95 m)

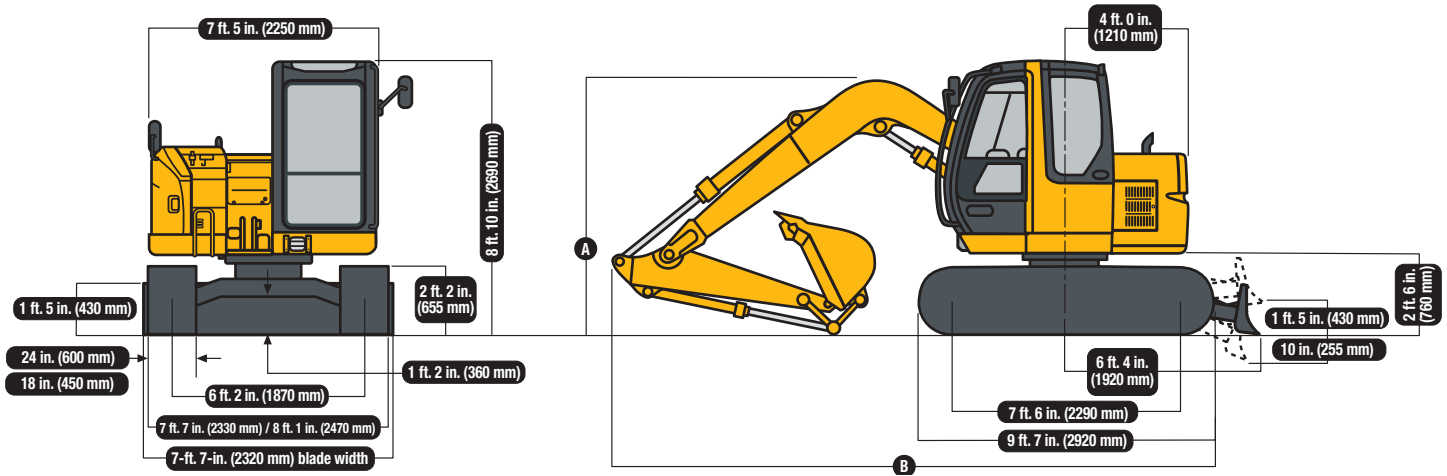

## Lift Capacities

**Boldface italic** type indicates hydraulic-limited capacities; lightface type indicates stability-limited capacities, in lb. (kg). Ratings at bucket lift hook; machine equipped with 0.36-cu.-yd. (0.28 m<sup>3</sup>), 30-in. (750 mm), 522-lb. (237 kg) bucket; and situated on firm, uniform supporting surface. Total load includes weight of cables, hook, etc. Figures do not exceed 87 percent of hydraulic capacities or 75 percent of weight needed to tip machine. All lift capacities are based on SAE J1097.

Load Point Height	5 ft. (1.52 m)		10 ft. (3.05 m)		15 ft. (4.57 m)		20 ft. (6.10 m)	
	Over Front	Over Side	Over Front	Over Side	Over Front	Over Side	Over Front	Over Side
<i>With 5-ft. 4-in. (1.62 m) arm, 24-in. (600 mm) triple semi-grouser shoes, and blade on ground</i>								
10 ft. (3.05 m)			<b>3,831 (1738)</b>	<b>3,831 (1738)</b>	<b>3,272 (1484)</b>	3,177 (1441)		
5 ft. (1.52 m)			<b>6,576 (2983)</b>	5,595 (2538)	3,495 (1585)	3,001 (1361)		
Ground Line			6,391 (2899)	5,307 (2407)	3,341 (1515)	2,854 (1295)		
-5 ft. (-1.52 m)	<b>7,883 (3576)</b>	<b>7,883 (3576)</b>	6,384 (2896)	5,301 (2405)	3,302 (1498)	2,816 (1277)		
-10 ft. (-3.05 m)			<b>5,258 (2385)</b>	<b>5,258 (2385)</b>				
<i>With 6-ft. 11-in. (2.12 m) arm, 24-in. (600 mm) triple semi-grouser shoes, and blade on ground</i>								
15 ft. (4.57 m)					<b>2,481 (1125)</b>	<b>2,481 (1125)</b>		
10 ft. (3.05 m)			<b>2,888 (1310)</b>	<b>2,888 (1310)</b>	<b>2,792 (1266)</b>	<b>2,792 (1266)</b>		
5 ft. (1.52 m)			<b>5,614 (2546)</b>	<b>5,614 (2546)</b>	3,527 (1600)	3,029 (1375)	2,163 (981)	1,856 (842)
Ground Line			6,406 (2906)	6,317 (2412)	3,335 (1513)	2,846 (1291)	2,098 (952)	1,793 (813)
-5 ft. (-1.52 m)	<b>6,415 (2910)</b>	<b>6,415 (2910)</b>	6,310 (2862)	5,228 (2371)	3,253 (1476)	2,767 (1255)		
-10 ft. (-3.05 m)	<b>10,613 (4814)</b>	<b>10,613 (4814)</b>	<b>6,198 (2811)</b>	5,331 (2418)				

## Lift Capacities (continued)

75C

**Boldface italic** type indicates hydraulic-limited capacities; lightface type indicates stability-limited capacities, in lb. (kg). Ratings at bucket lift hook; machine equipped with 0.36-cu.-yd. (0.28 m<sup>3</sup>), 30-in. (750 mm), 522-lb. (237 kg) bucket; and situated on firm, uniform supporting surface. Total load includes weight of cables, hook, etc. Figures do not exceed 87 percent of hydraulic capacities or 75 percent of weight needed to tip machine. All lift capacities are based on SAE J1097.

Load Point Height	5 ft. (1.52 m)		10 ft. (3.05 m)		15 ft. (4.57 m)		20 ft. (6.10 m)	
	Over Front	Over Side	Over Front	Over Side	Over Front	Over Side	Over Front	Over Side
<i>With 5-ft. 4-in. (1.62 m) arm, 18-in. (450 mm) rubber crawler pads, and blade on ground</i>								
10 ft. (3.05 m)			<b>3,831 (1738)</b>	<b>3,831 (1738)</b>	<b>3,272 (1484)</b>	3,093 (1403)		
5 ft. (1.52 m)			6,520 (2957)	5,450 (2472)	3,394 (1539)	2,918 (1324)		
Ground Line			6,208 (2816)	5,162 (2341)	3,240 (1470)	2,770 (1256)		
-5 ft. (-1.52 m)	<b>7,883 (3576)</b>	<b>7,883 (3576)</b>	6,201 (2813)	5,155 (2338)	3,200 (1451)	2,733 (1240)		
-10 ft. (-3.05 m)			<b>5,258 (2385)</b>	<b>5,258 (2385)</b>				
<i>With 6-ft. 11-in. (2.12 m) arm, 18-in. (450 mm) rubber crawler pads, and blade on ground</i>								
15 ft. (4.57 m)					<b>2,481 (1125)</b>	<b>2,481 (1125)</b>		
10 ft. (3.05 m)			<b>2,888 (1310)</b>	<b>2,888 (1310)</b>	<b>2,792 (1266)</b>	<b>2,792 (1266)</b>		
5 ft. (1.52 m)			<b>5,614 (2546)</b>	<b>5,614 (2546)</b>	3,425 (1554)	2,945 (1336)	2,092 (949)	1,797 (815)
Ground Line			6,223 (2823)	5,171 (2346)	3,234 (1467)	2,763 (1253)	2,027 (919)	1,734 (787)
-5 ft. (-1.52 m)	<b>6,415 (2910)</b>	<b>6,415 (2910)</b>	6,127 (2779)	5,082 (2305)	3,151 (1429)	2,683 (1217)		
-10 ft. (-3.05 m)	<b>10,613 (4814)</b>	<b>10,613 (4814)</b>	<b>6,198 (2811)</b>	5,185 (2352)				

## Buckets

A full line of buckets is offered to meet a wide variety of applications. Tooth selection includes either the John Deere Fanggs®, Standard, Tiger, Twin Tiger, Abrasion panel, or Flare tooth, or the ESCO (Vertalok) Standard, Tiger, Twin Tiger, or Flare tooth. Replaceable cutting edges are available through John Deere parts. Optional side cutters add 6 inches (150 mm) to bucket widths.

Type Bucket	Bucket Width		Bucket Capacity*		Weight		Bucket Dig Force		Arm Dig Force 5 ft. 4 in. (1.62 m)		Arm Dig Force 6 ft. 11 in. (2.12 m)		Bucket Tip Radius		No. Teeth
	in.	mm	cu. yd.	m <sup>3</sup>	lb.	kg	lb.	kN	lb.	kN	lb.	kN	in.	mm	
Heavy-Duty	24	610	0.27	0.21	495	225	11,185	49.8	8,500	37.8	7,190	32.0	39.0	991	5
Plate Lip	30	760	0.36	0.28	522	237	11,185	49.8	8,500	37.8	7,190	32.0	39.0	991	6
	36	915	0.45	0.34	544	247	11,185	49.8	8,500	37.8	7,190	32.0	39.0	991	7
Ditching	60	1525	0.75	0.57	564	256	12,465	55.4	8,845	39.3	7,435	33.1	34.1	866	0

\*All capacities are SAE heaped ratings.

## 75C EXCAVATOR

**Key:** ● Standard equipment ▲ Optional or special equipment

\*See your John Deere dealer for further information.

### 75C Engine

- Certified to EPA Tier 2 emissions
- Auto-idle system
- Batteries (two 12 volt), 100-min. (550 CCA) reserve capacity
- Dual-element dry-type air filter
- Enclosed fan guard (conforms to SAE J1308)
- Engine coolant to -34°F (-37°C)
- Fuel filter with water separator
- Full-flow oil filter
- Radiator trash screen
- Muffler, under hood, with vertical curved end exhaust stack

### Hydraulic System

- Auxiliary hydraulic valve section
- Hydraulic pilot controls
- Reduced-drift valve for boom down
- Spring-applied, hydraulically released automatic swing brake
- ▲ Auxiliary hydraulic and electric pilot controls
- ▲ Control pattern change valve
- ▲ Hydraulic filter restriction indicator kit

### Undercarriage

- Planetary final drive with axial piston motors
- Propel motor shields
- Two-speed propel with automatic shift
- Track guides, front idler
- Triple semi-grouser shoes, 24 in. (600 mm)
- ▲ Rubber crawler pads, 18-in. (450 mm), with backfill blade
- Undercarriage with blade
- Upper carrier roller (1)

### 75C Upperstructure

- Counterweight, 3,042 lb. (1380 kg)
- Right- and left-hand mirrors
- Vandal locks with ignition key: Cab door / Engine hood / Fuel cap / Service doors

### Front Attachments

- ▲ Arm, 5 ft. 4 in. (1.62 m)
- ▲ Arm, 6 ft. 11 in. (2.12 m)
- Centralized lubrication system
- Dirt seals on all bucket pins
- ▲ Auxiliary hydraulic lines with shutoff valve
- ▲ Buckets: Ditching / Heavy duty / Side cutters and teeth
- ▲ Hydraulic coupler

### Operator's Station

- Adjustable seat with independent control positions (seat-to-pedals)
- AM/FM radio
- Auto climate control/air conditioner, 20,000 Btu/hr. (5.9 kW) with heater and pressurizer
- Built-in Operator's Manual storage compartment and manual
- Cell-phone power outlet, 12 volt, 60 watt, 5 amp
- Coat hook
- Deluxe suspension cloth seat with 4-in. (100 mm) adjustable armrests and lumbar support
- Front windshield wiper with intermittent speeds
- Gauges (illuminated): Engine coolant / Fuel
- Horn, electric on left control lever
- Hourmeter, electric
- Hydraulic shutoff lever, all controls
- Interior light
- Large cup holder

### 75C Operator's Station (continued)

- Machine Information Center (MIC)
- Mode selectors (illuminated): Power modes – two / Travel modes – two with automatic shift / Work mode – one
- Monitor system with alarm features: Auto-idle indicator light / Engine air cleaner restriction indicator light / Engine coolant temperature indicator light with audible alarm / Engine oil pressure indicator light with audible alarm / Fluid level: Engine coolant level indicator light and engine oil level indicator light / Low alternator charge indicator light / Low fuel indicator light / Preheat indicator
- Motion alarm with cancel switch (conforms to SAE J994)
- Propel pedals and levers
- Seat belt, 2 in. (51 mm), retractable
- ▲ Seat belt, 3 in. (76 mm), non-retractable
- Tinted glass
- Transparent tinted overhead hatch with sunshade
- ▲ Circulation fan
- ▲ Protection screen for cab lower front window
- ▲ Rear secondary exit window kit
- ▲ Window vandal protection covers
- ▲ 24- to 12-volt D.C. radio convertors, 10 amp

### Electrical

- 30-amp alternator
- Blade-type multi-fused circuits
- Positive terminal battery covers

### Lights

- Work lights: Halogen / One mounted on boom / One mounted on frame

## CONTROL OWNING AND OPERATING COSTS

Customer Personal Service (CPS) is part of John Deere's proactive, fix-before-fail strategy on machine maintenance that will help control costs, increase profits, and reduce stress. Included in this comprehensive lineup of ongoing programs and services are:

**Fluid analysis program** – tells you what's going on inside *all* of your machine's major components so you'll know if there's a problem *before* you see a decline in performance. Fluid analysis is included in most extended coverage and preventive-maintenance agreements.

**Component life-cycle data** – gives you vital information on the projected life span of components and lets you make informed decisions on machine maintenance by telling you approximately how many hours of use you can expect from an engine, transmission, or hydraulic pump. This information can be used to preempt catastrophic downtime by servicing major components at about 80 percent of their life cycle.

**Preventive Maintenance (PM) agreements** – give you a fixed cost for maintaining a machine for a given period of time. They also help you avoid

downtime by ensuring that critical maintenance work gets done right and on schedule. On-site preventive maintenance service performed where and when you need it helps protect you from the expense of catastrophic failures and lets you avoid waste-disposal hassles.

**Extended coverage** – gives you a fixed cost for machine repairs for a given period of time so you can effectively manage costs. Whether you work in a severe-service setting or just want to spread the risk of doing business, this is a great way to custom-fit coverage for your operation. And an extended coverage contract also travels well because it's backed by John Deere and is honored by *all* Deere construction dealers.

**Customer Support Advisors (CSAs)** – Deere believes the CSA program lends a *personal* quality to Customer Personal Service (CPS). Certified CSAs have the knowledge and skills for helping make important decisions on machine maintenance and repair. Their mission is to help you implement a plan that's right for *your* business and take the burden of machine maintenance off your shoulders.



JOHN DEERE

DKAX75C Litho in U.S.A. (06-09)

Net engine power is with standard equipment including air cleaner, exhaust system, alternator, and cooling fan at test conditions specified per ISO9249. No derating is required up to 10,000-ft. (3050 m) altitude.

Specifications and design subject to change without notice. Wherever applicable, specifications are in accordance with SAE standards. Except where otherwise noted, these specifications are based on a unit with standard equipment; 0.36-cu.-yd. (0.28 m<sup>3</sup>), 30-in. (750 mm), 522-lb. (237 kg) bucket; 24-in. (600 mm) triple semi-grouser shoes; 3,042-lb. (1380 kg) counterweight; 6-ft. 11-in. (2.12 m) arm; full fuel tank; and 175-lb. (79 kg) operator.

