



J-Supporter Smart Glasses

Starter Kit

(Model: J-102)

User's Manual

English
version 1.0

Contents :

1. A Quick Tour of J-Supporter (J-102)	2
Computer	2
Headset	2
2. Specifications	3
Operating Frequency Bands	4
Standard Accessories	4
Additional Accessories (for J-102)	5
3. Using J-Supporter.....	6
Turn J-Supporter On/Off.....	6
Software Functions	6
Home Screen	7
Setting Up J-Supporter	9
Connecting to Wireless Network.....	10
Setup Time	11
Setup Bluetooth Function.....	12
Check Software version	12
Power Status	13
4. For Developers: Install your own Apps	14
5. Safety and Handling Information:.....	18
6. Regulatory Statements.....	19
7. Copyright Information.....	23

1. A Quick Tour of J-Supporter (J-102)

Headset

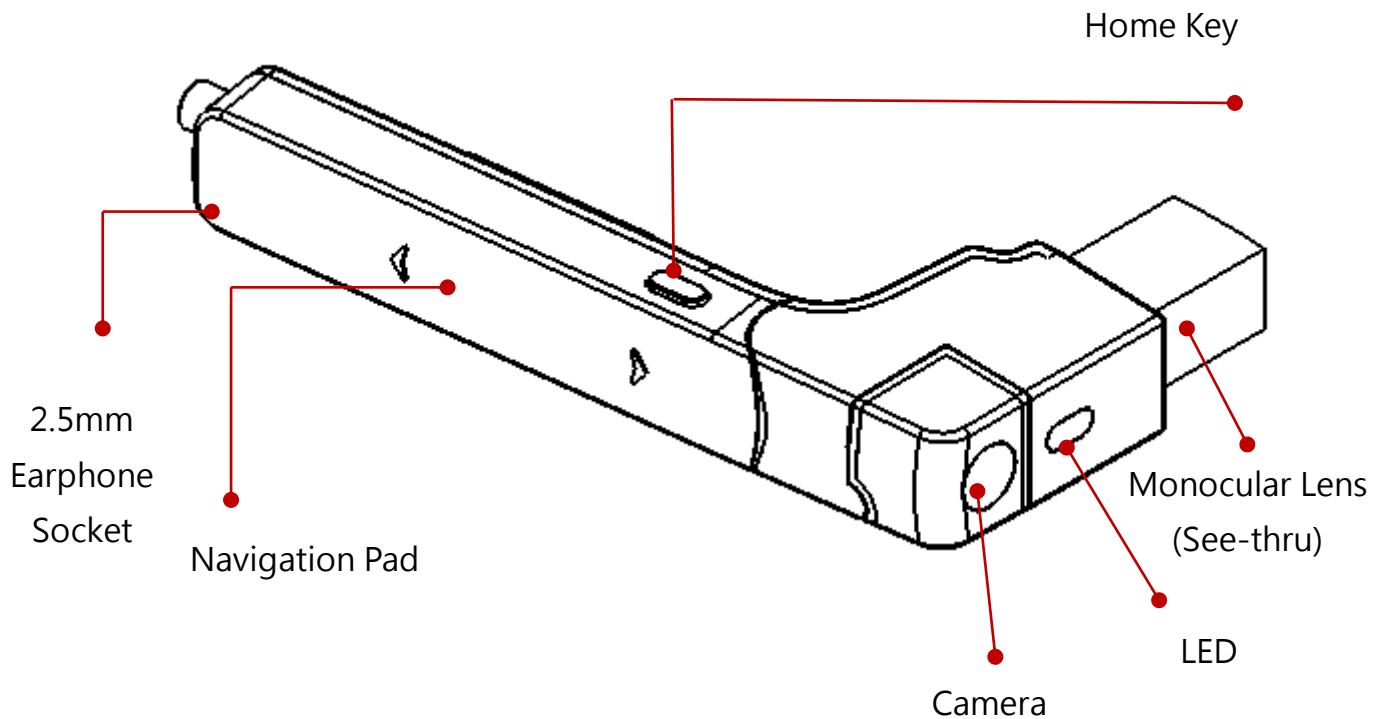

Computer

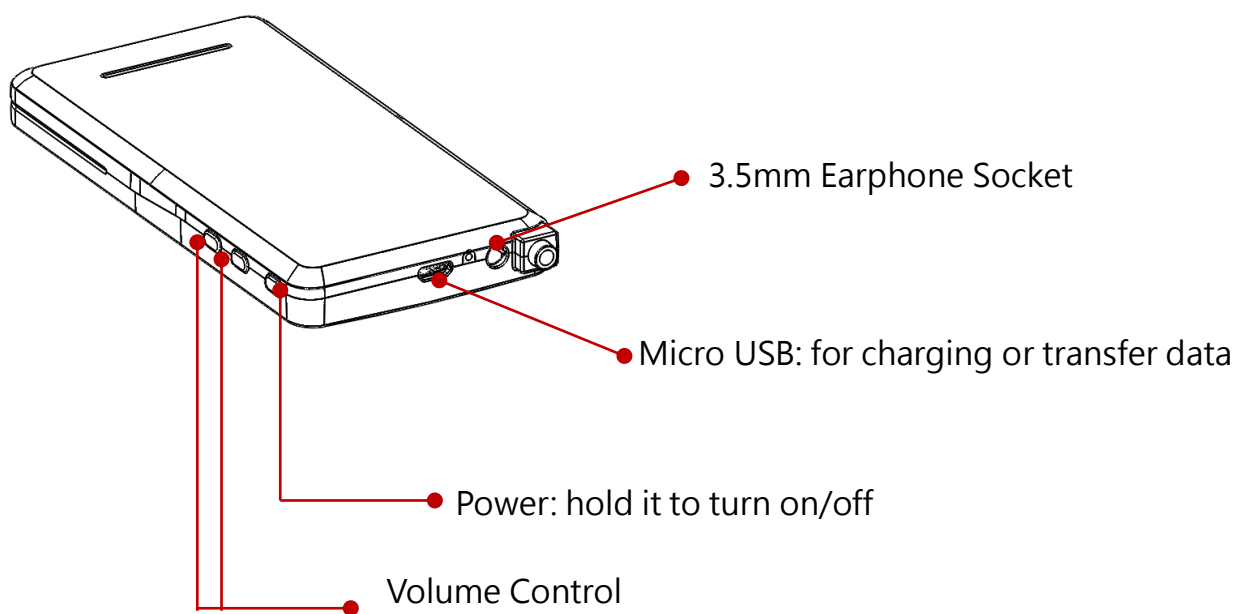

2. Specifications

Operating System	Android 5.1
Processor	Texas Instrument Dual Core OMAP4460
Display Panel	Monocular (See-through) Field of View : 16 degree Resolution : 800x480 (480p)
Internal Memory	RAM : 1GB Storage : 16GB
Wireless Connectivity	Bluetooth 4.0 Dual mode (BLE 4.0+ Classic Bluetooth 2.0/2.1/3.0) Wi-Fi, 802.11 b/g/n 2.4G
I/O Connectors	1 x Micro USB connector 2 x Earphone sockets (1 x 2.5mm & 1 x 3.5mm)
Camera	8 Million pixels (auto-focus supported) Picture resolution up to 3264 x 2448 · Support 1080p video
Sensor	GPS Ambient Light Sensor 3-axis Gyroscope 3-axis Accelerometer 3-axis Magnetometer
Mic	1 x internal Mic
Navigation	Touch pad (voice command function need supported by third party' s solution)
Supported Still-Image Format	JPEG, PNG, BMP, GIF
Supported Video Format	MP4 (MPEG4/H.264+AAC), MPEG2 (H.264+AAC), VP8
Weight	Headset:27g Computer: 132g
Battery	Lithium polymer battery 3.7V · capacity up to 3,600 mAh
Power Input	5V/2A Charge via USB cable/adapter

Operating Frequency Bands

Wi-Fi operating frequency band(s) details are as follows:

- 802.11b
- 802.11g
- 802.11n HT20 (2.412~2.462GHz),

Bluetooth: 2.402~2.480 GHz

Standard Accessories



Arm Bag

Accommodates the J-Supporter computer set and a mobile power bank, and can be worn on user' s arm.



Charger

Include both micro usb cable and adapter for recharging J-Supporter.



- input 100-240V~ 50-60Hz 0.35A
- output 5V 2A



2.5mm earphone

Additional Accessories (for J-102)



Basic Len-less Frame

For right side wearing.



Helmet Adapter

An adapter with a ball joint secures the J-102 to the helmet and helps user adjust the smart glasses position freely.

3. Using J-Supporter

Turn J-Supporter On/Off

- Turn on: hold the "Power" button approximately 3 seconds to turn the device on.
- Turn off: hold the "Power" button approximately 8 seconds to turn the device off.
- Standby mode: tap the "Power" button once to turn off the lens display and enter standby mode.

Software Functions

Function	Descriptions
Setting	This allows users to set up J-Supporter, including wireless network, Bluetooth, time, brightness, font size and language for navigation.
Support (The Free Trial is only for designated project customers)	<p>This enables remote two-way communication so that the on-site staff can transfer video footages to a distant personnel through J-Supporter. The distant personnel can provide instructions overlapping onto the footage in a real-time manner to help conduct the tasks.</p> <p>This service requires fee payment. Once the payment is made, user will receive a user account offering 300-minute of usage.</p> <p>This is a paid service, and only for customers who participate in the designated project can get free trial program (from 300 minutes to 30 days).</p>

Home Screen

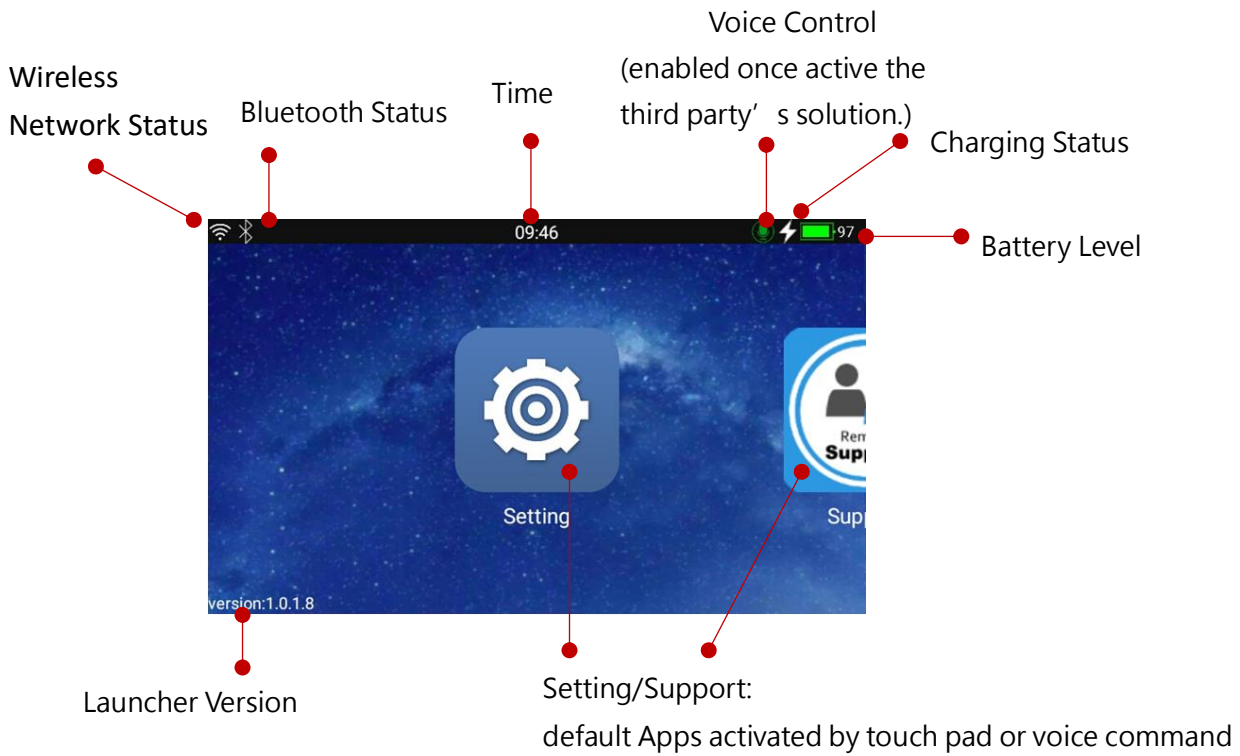

- Navigation Pad(Touch Pad) (please make sure your installed Apps support touch pad navigation on smart glasses)

Touch Input	Function
Single Tap	Enter Menu/Confirm
Slide down	Back
Slide forward/back	Switch App/Function

- HOME Key

Touch Input	Function
Tap lightly	Enter Menu/Confirm
Hold it approx. 3 seconds	Return to Home Screen

- Voice control (demo function)

Double-click the home button to switch the microphone on/off.

The voice control function in J-Supporter is demonstration function and need to be connected to the Internet to be used.

When J-Supporter is connected to the Internet, voice control is automatically enabled.

Default Voice Commands (2 sets for demo version)





By Mandarin	By English	Function
“設定”	“setting”	Activates Setting App
“遠端協助”	“Support”	Activates Remote Support App

You need to find third-party vendors to cooperate and develop voice control functions.

Setting Up J-Supporter

The setup of J-Supporter requires the use of QR Code. To get the QR Code, please download and install our “Glasses Aide” App.

- 1. Please download “Glasses Aide” APK file (GlassesAide_2.2.1.4_Release.apk) from the link <http://www.jorjin.com/product.php?id=177>, it is in the category “Download ”

Key Features	Description	Download
	J-Supporter Smart Glasses (J-100 EVK.) Datasheet (20180222)	 Download
	[For App Developer] Application 2.3.3_6	 Download
	[For Smart Glasses Setup] GlassAide 2.2.1.4	 Download
	[Remote Support] Android Client 1.1.0.9	 Download
	[Remote Support] PC Client 1.3.0.35	 Download

- 2. Install “Glasses Aide” APK into your Android smartphone as an App. (You may need to use a third-party tool or the adb command to do this)

Connecting to Wireless Network

- 1. Open "Glasses Aide" APK on your Android-based smartphone.



- 2. Open the Wi-Fi setting option and scan available Wi-Fi connections. Then choose a Wi-Fi connection from the scanned list.



- 3. Enter the necessary information for the Wi-Fi connections including SSID and password, and then tap to generate QR Code to connect to wireless network.

Wi-Fi SSID : AP-Guest

Password :

Security : WPA/WPA2

Generate QR Code



- 4. The "Setting" screen should appear. Simply tap "Scan & Connect Wi-Fi" .
Note: you must have scanned the QR Code to access this step.

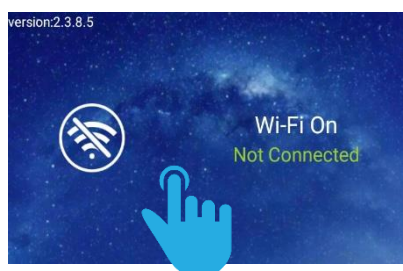

Tap on the Wi-Fi status screen

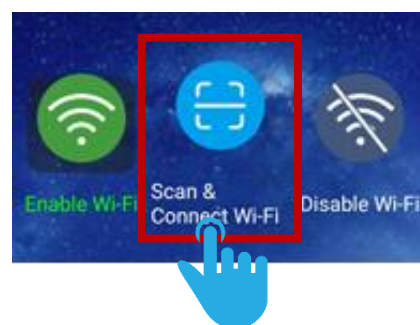

Tap on "Scan & Connect Wi-Fi"

The device will be automatically connected to the same Wi-Fi network if the setup is performed properly.

Setup Time

- 1. Open "Glasses Aide" APK on your Android-based smartphone.



- 2. Open the "Time" option.



- 3. Input current time and generate QR Code.

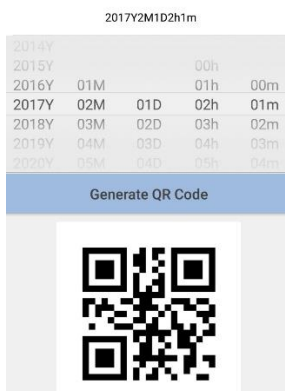

- 4. The "Setting" screen should appear. Simply tap on the time setup screen.
Note: you must have scanned the QR Code in the last step.

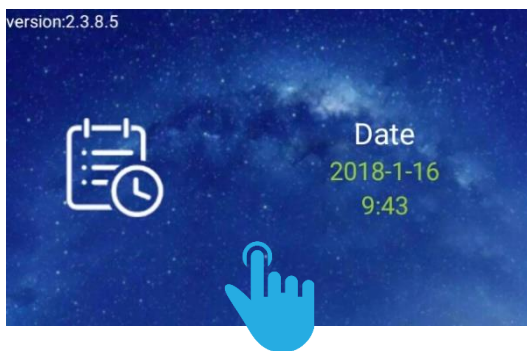

Setup Bluetooth Function

- 1. Enter the Bluetooth setup screen. Tap it and then choose "Discover Bluetooth Devices" to search available Bluetooth devices.

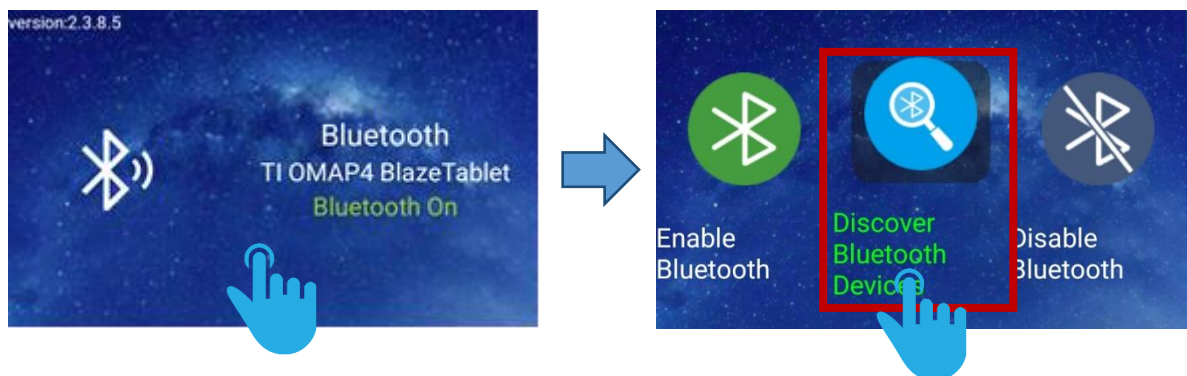

- 2. Set up the Bluetooth connections for the device(s) you wish to connect with your J-Supporter Smart Glasses. Please perform the setup based on the device user's guide.

Check Software version

- You can find the "Software Version" option in the "Settings" function, tap the touchpad to see the software and version information currently provided by J-Supporter.

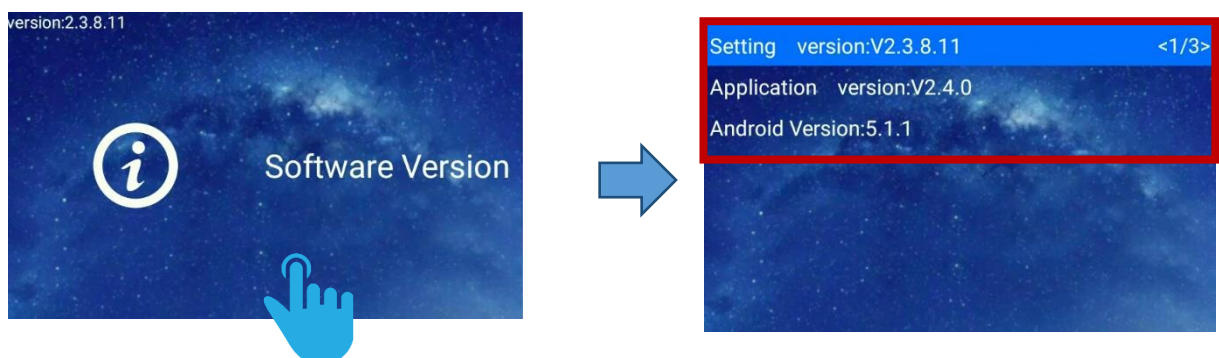

Power Status

Power Remaining	Status Indicator
< 20%	Red
20% - 90%	Orange
90% - 97%	Green (flashing)
97% - 100%	Green (constant)

4. For Developers: Install your own Apps

- Install “Application Folder” and “System Folder”

Note: The App you installed, or the app in the native Android system may not support using navigation pad. You may need to connect the wireless mouse to J-Supporter for operating them.

- 1. Please download “Application Folder” APK (Current version is 2.4.0.0) from Jorjin website. (download url: <http://www.jorjin.com/product.php?id=177>)

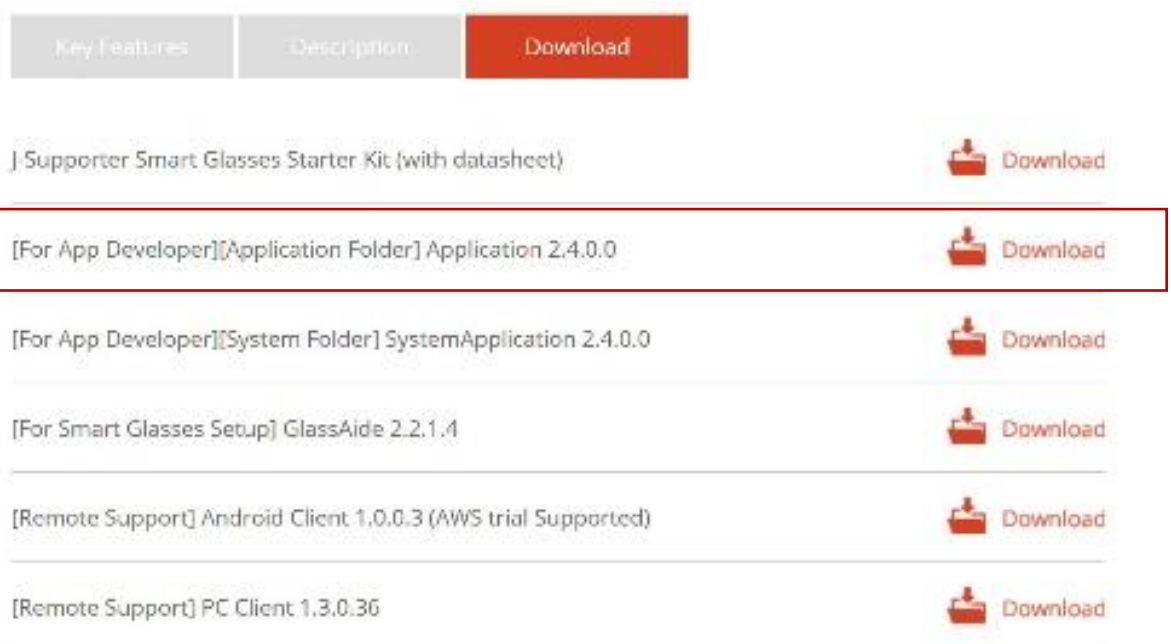

- 2. Establish connection between J-Supporter and your computer. Then, use Android “adb” command to install “Application” APK.

To use Android adb command, you need to download “Android Studio” first. Use the following instructions to insall “Application” APK.

```
adb install TvApplication_2.4.4_0_Release.apk
```



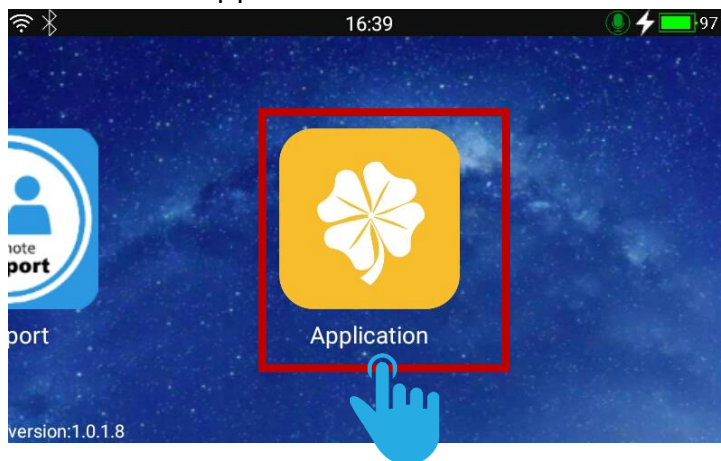

- 3. Once the installation is completed, the "Application" App will appear on the screen of J-Supporter

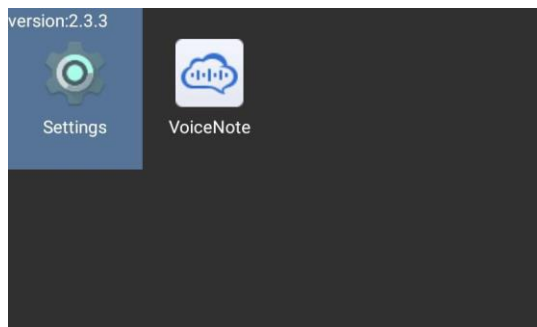

The apps you install later will appear in the "Application" .



- 4. Please download "System Folder" APK (Current version is 2.4.0.0) from Jorjin website. (download url: <http://www.jorjin.com/product.php?id=177>)

Key Features	Description	Download
	J-Supporter Smart Glasses Starter Kit (with datasheet)	 Download
	[For App Developer][Application Folder] Application 2.4.0.0	 Download
	[For App Developer][System Folder] SystemApplication 2.4.0.0	 Download
	[For Smart Glasses Setup] GlassAide 2.2.1.4	 Download
	[Remote Support] Android Client 1.0.0.3 (AWS trial Supported)	 Download
	[Remote Support] PC Client 1.3.0.36	 Download

- 5. Refer to step 2 to install System Application into J-Supporter.
- 6. After installation, you will be able to see the new System Application folder in the Application app. You can access the original Android Device Setting through System Application app.

- **About SDK and Technical Support**

J-Supporter Smart glasses can be developed by using the standard Android API. However, Jorjin still prepares the Basic SDK for developers to access camera and navigation pad functions.

If you need the Basic SDK service, please contact your business contactor.

5. Safety and Handling Information:

Read these instructions before operation

- Please contact professional technicians when replacing batteries, to avoid any potential heat issues.
- Please do NOT disassemble the product to avoid damages or hazards, and be aware that the parts inside cannot be used individually.
- Please stop using the device if it is damaged, and contact Jorjin for repair service immediately.
- Disassembling the device or removing the chassis may cause electrical shock. For repair, please contact Jorjin.
- Please apply dry cloth and turn the device off to clean it.
- Please do NOT place the device in proximity with any heat source, such as heater, oven, chamber or any object that may result in fire or explosion.
- Please do NOT expose the device to dust.
- Please do NOT allow any liquid or solvents to touch the product to avoid electrical shock. In case it happens, please apply dry cloth to wipe the device.
- Please do NOT place the device in locations subject to sudden changes in ambient temperatures. Doing so may result in fogs in the device.

6. Regulatory Statements

WARNING: Changes or modifications made to this equipment not expressly approved by JORJIN TECHNOLOGIES INC. for compliance could void the user' s authority to operate the equipment.

FCC Statement

This device complies with Part 15 of the FCC Rules. Operation is subject to the following two conditions:

- (1) This device may not cause harmful interference, and
- (2) This device must accept any interference received, including interference that may cause undesired operation.

Attention that changes or modification not expressly approved by the party responsible for compliance could void the user' s authority to operate the equipment.

Note: This product has been tested and found to comply with the limits for a Class B digital device, pursuant to Part 15 of the FCC Rules. These limits are designed to provide reasonable protection against harmful interference in a residential installation. This product generates, uses, and can radiate radio frequency energy and, if not installed and used in accordance with the instructions, may cause harmful interference to radio communications. However, there is no guarantee that interference will not occur in a particular installation. If this product does cause harmful interference to radio or television reception, which can be determined by turning the equipment off and on, the user is encouraged to try to correct the interference by one or more of the following measures:

- Reorient or relocate the receiving antenna.
- Increase the separation between the equipment and receiver.
- Connect the equipment into an outlet on a circuit different from that to which the receiver is connected.
- Consult the dealer or an experienced radio/TV technician for help.

Please take attention that changes or modification not expressly approved by the party responsible for compliance could void the user' s authority to operate the equipment.

SAR is measured with the device at 0 mm to the extremity, while transmitting at the highest certified output power level in all frequency bands of the device.

After the laboratory measurement, the SAR value is 0.63W/Kg for 2.4G Band which satisfies the RF exposure requirement

This device and its antenna(s) must not be co-located or operating in conjunction with any other antenna or transmitter. The County Code Selection feature is disabled for products marketed in the US.

FCC Caution

1. Any changes or modifications not expressly approved by the party responsible for compliance could void the user' s authority to operate this equipment.

2. This transmitter must not be co-located or operating in conjunction with any other antenna or transmitter.

Europe

European declaration of conformity

According to ISO / IEC Guide 22 and EN 450 14 Manufacturer' s Name: JORJIN TECHNOLOGIES INC.

Manufacturer' s Address:17F,No.239, Sec. 1, Datong Rd., Xizhi Dist., New Taipei City, Taiwan.
Declares, under our sole responsibility, that the product: Product Name: J-Supporter Smart Glasses.

Model Number: J-102

Conforms to the following Product Specifications:

- RED 2014/53/EU; LVD 2014/35/EU; EMC 2014/53/EU RED
- ETSI EN 300 328
- ETSI EN 303 413
- ETSI EN 301 489-1 /-3 /-17/ -19
- EN 55032: 2012+AC: 2013
- EN 55035: 2017
- EN 60950-1:2006/A11:2009/A1:2010/

Supplementary information

In addition, the product is battery powered and the power supply provided with this product has been certified to IEC 60950: 2005 2nd edition +Am1:2009+Am2: 2013. As manufacturer, we declare under our sole responsibility that the equipment follows the provisions of the Standards stated above.

Importer of Record

CAUTION - Only approved accessories may be used with this equipment. In general, all cables must be high quality, shielded, correctly terminated and normally restricted to two meters in length. Power supplies approved for this product employ special provisions to avoid radio interference and should not be altered or substituted. Unapproved modifications or operations beyond or in conflict with these instructions for use may void authorization by the authorities to operate the equipment.

This product has been tested and found to comply with all requirements for CE Marking and sale within the European Economic Area (EEA). The device has Bluetooth and wireless LAN approval and satisfies the requirements for Radio and Telecommunication Terminal Equipment specified by European Council Directive 2014/53/EU. These requirements provide reasonable protection against harmful interference when the equipment is operated appropriately in a residential or commercial environment.

The device is intended for connection to European Networks

a. Caution:

Risk of explosion if battery replaced by an incorrect type.

Dispose of used batteries according to the instructions.

b. Make sure the temperature for adapter will not be higher than 35 °C.

Battery safety

Lithium-Ion batteries are classified by the U. S. Federal Government as non-hazardous waste and are safe for disposal in the normal municipal waste stream. These batteries contain recyclable materials and are accepted for recycling. Dispose of used batteries in accordance with local regulations.

WARNING – Non-approved batteries will not function in the device. Use only the battery for the system for which it was specified. Only use the battery with a charging system that has been qualified with the system per this standard. Use of an unqualified battery or charger may present a risk of fire, explosion, leakage, or other hazard.

WARNING – There are no user-serviceable parts in the batteries. Do not disassemble or open, crush, bend or deform, puncture, or shred the battery. Do not modify or remanufacture, attempt to insert foreign objects into the battery, immerse or expose to water or other liquids, or expose to fire, explosion, or other hazard. Do not expose to temperatures above +40 °C (+103 °F).

WARNING – Improper battery use may result in a fire, explosion, or other hazard. Do not short circuit a battery or allow metallic or conductive objects to contact the battery terminals.

Avoid dropping the device or battery. If dropped, especially on a hard surface, and the user suspects damage to the battery, take it to a service center for inspection.

In the event of a battery leak, do not allow the liquid to come in contact with the skin or eyes. If contact has been made, wash the affected area with large amounts of water and seek medical advice.

Battery usage by children should be supervised.

Power supply safety

WARNING – Ensure the input voltage on the adapter matches the voltage in your location. Ensure the Class I adapter has prongs compatible with your outlets and earthing connection. The AC power supply is designed for indoor use only. Avoid using the AC power supply in wet areas.

Unplug the power supply from power when not in use.

Do not short the output connector.

8. Copyright Information:



Copyright © 2018 JORJIN TECHNOLOGIES INC.

JORJIN and the JORJIN logo are trademarks of JORJIN TECHNOLOGIES INC. Other company and product names may be trademarks or registered trademarks of the respective owners with whom they are associated.

Jorjin may update this user manual from time to time. You can get the most current version which can be found at <http://www.jorjin.com> .



CORPORATE OFFICE (HQ)

JORJIN TECHNOLOGIES INC.
17F, No.239, Sec. 1, Datong Rd.,
Xizhi Dist., New Taipei City
22161, Taiwan R.O.C.

TEL: +886-2-2649-0055
Fax: +886-2-26425477
www.jorjin.com
Contact: sales@jorjin.com

CHINA OFFICE

Rm701,World Plaza,NO.1168
Huyi Road · Nanxiang Town,
Jiading District · Shanghai,China

TEL: +886-2-2649-0055
Fax: +886-2-26425477
Contact: sales@jorjin.com



Jorjin website
Contact for latest product updates.