

USERS MANUAL



Tron AIS-SART



www.jotron.com



www.jotron.com

EC Declaration of Conformity, available at www.jotron.com

The serial number is identical to the user ID of the unit.

Abbreviations and definitions

EMC

Electromagnetic Compatibility

LED

Light Emitting Diode

PWB

Printed Wire Board

RF

Radio Frequency

AIS-SART

Search and Rescue Unit based on the AIS system

VHF

Very High Frequency



Amendment Records

AMEND- MENT NO.	INCRP. BY	DATE	PAGE(S)	VERSION	REASON FOR CHANGE
1	ES	16.06.09	Total: 28	A	New product
2	ES	22.11.09	Page 2	B	New information
3	FIT	08.12.09	Page 22-27	C	Updated information
4	FIT	22.03.10	Total: 30	D	Updated information
5	FIT	20.04.10	Total: 34	E	Updated information
6	FIT	10.06.10	Page 28	F	Updated information
7					
8					

The information in this book has been carefully checked and is believed to be accurate. However, no responsibility is assumed for inaccuracies.



CAUTION!

This equipment contains CMOS integrated circuits. Observe handling precautions to avoid static discharges which may damage these devices.

Jotron AS reserves the right to make changes without further notice to any products or modules described herein to improve reliability, function or design. Jotron AS does not assume any liability arising out of the application or use of the described product.



WARNING / IMPORTANT

Jotron AS is a prime manufacturer of safety equipment designed for rescue of human lives and their property. For safety equipment to be effective in line with the design parameters it is important that they are handled, stowed and maintained in compliance with the manufacturers instructions. Jotron AS cannot be held responsible for any damage caused due to incorrect use of the equipment or breach of laid down procedures or for failure of any specific component or other parts of the equipment.

The chapter covering battery replacement (6.2.1) is added for information only. Jotron AS does not take any responsibility for improper disassembling/assembly of the beacon. We strongly recommend all service to be done by authorized Jotron agents. In addition to normal service, Jotron agents have the necessary equipment and knowledge to test the operational functions of the beacon. Non-original maintenance and/or service parts may destroy the equipment function and performance.

Battery safety data sheet

(Form: EEC directive 91/155)

(2) SAFETY ADVICE

- S2 Keep out of reach of children.
- S8 Keep container dry.
- S26 In case of contact with eyes, rinse immediately with plenty of water and seek medical advice.
- S43 In case of fire, use D type extinguishers. Never use water.
- S45 In case of accident or if you feel unwell, seek medical advice immediately (show the label where possible).

(3) FIRST AID MEASURES

In case of contact of cell contents with eyes, flush immediately with water for 15 min. With skin, wash with plenty of water and take off contaminated clothes. If inhaled, remove from exposure, give oxygen, and seek medical advice.

(4) FIRE-FIGHTING MEASURES

Extinguishing media

Suitable: Type D fire extinguishers

Not to be used: Water - CO₂ - Halon, dry chemical or foam extinguishers

Special exposure hazards

Generation of chlorine, sulphur dioxide, disulphur dichloride during thermal decomposition.

Special protective equipment

Use protective working boots, rubber apron and safety glasses with side shields.





Table of contents

1	General description	8
1.1	Tron AIS-SART features	9
1.2	Battery module	10
2	Technical specifications	11
2.1	Electrical specifications	11
2.2	Mechanical specification	11
3	Functional description	12
3.1	General	12
3.1.1	Tron AIS-SART electronic assembly	12
3.1.2	Battery module	13
3.1.3	Bottom lid	13
4	Installation	14
4.1	Brackets	14
4.1.1	Wall bracket	14
4.1.2	Lifeboat bracket	15
4.2	Installation tips	17
4.2.1	How to use the brackets in life rafts	17
4.2.2	Installation diagram	18
4.2.3	Mounting a pipe	18
4.3	Using the telescopic pole	20
4.4	Using the 10m rope	21
5	Operating instructions	22
5.1	Activation	22
5.2	Reception on nearby vessels AIS transponders and ECS/ECDIS or chart plotters	23
5.2.1	Reception on a non AIS-SART compliant AIS transponder	23
5.2.2	Reception on a non AIS-SART compliant electronic chart (ECS/ECDIS)	23
5.2.3	Reception on an AIS-SART compliant AIS transponder	24
5.2.4	Reception on an AIS-SART compliant electronic chart (ECS/ECDIS)	24
5.3	Test	25
5.4	Reception on nearby vessels AIS transponders and ECS/ECDIS or chart plotters	26
5.4.1	Reception on a non AIS-SART compliant AIS transponder	26
5.4.2	Reception on a non AIS-SART compliant electronic chart (ECS/ECDIS)	26



www.jotron.com

5.4.3	Reception on an AIS-SART compliant AIS transponder	27
5.4.4	Reception on an AIS-SART compliant electronic chart (ECS/ECDIS)	27
6	Maintenance and troubleshooting	28
6.1	Maintenance	28
6.2	Service	28
6.2.1	Replacing the battery module	29
6.2.2	Battery disposal	31
6.2.3	Incineration	31
6.2.4	Land filling	31
6.2.5	Recycling	31
7	Service agents	32





1 GENERAL DESCRIPTION

Tron AIS-SART is a battery powered AIS emergency transmitter in a sealed waterproof enclosure consisting of:

1. Tron AIS-SART unit
2. Mounting rope for life rafts / life boats.

The Tron AIS-SART is developed by Jotron AS to meet the rules and regulations for use on vessels and life rafts in the maritime service.

Tron AIS-SART meets the specifications for use in search and rescue operations at sea.

The operating range of the Tron AIS-SART is 7 -10 nautical miles from vessel AIS Class-A, and more than 40 nautical miles from an airborne AIS receiver.

Tron AIS-SART is buoyant, however to obtain maximum performance, the unit should be placed in a vertical position and as high up as possible in order to achieve maximum coverage.

Several mounting brackets and mounting aids are available to ensure correct mounting and use of the radar unit.

The purpose of the Tron AIS-SART is to perform a secondary alarm when search and rescue units are searching for a life raft / lifeboat in distress. The Tron AIS-SART includes a built-in GPS, which will help the units to pinpoint exactly where the distressed boat is located in a larger area. This is done with the help of the AIS on the searching ship or helicopter. When started, the Tron AIS-SART sends its position data in an ordinary AIS message.

In addition the Tron AIS-SART sends a safety text message every fourth minute, containing text: "AIS SART". This will be received by other AIS systems within the range.

The batteries of the Tron AIS-SART will last at least 96 hours when activated.



To save battery capacity in case of a situation where the unit is needed, the use should be limited to tests and emergency situations.

1.1 TRON AIS-SART FEATURES

Watertight:

Tron AIS-SART is watertight to a depth of minimum 1 meter.

Buoyant:

Tron AIS-SART is buoyant in case the unit is accidentally dropped into the water. To increase coverage the AIS-SART should always be held or mounted as high as possible.

Rugged design:

The Tron AIS-SART will withstand a drop from 20 meters into the water. It is resistant to seawater, oil and sunlight.

Handling:

Tron AIS-SART is designed for easy operation, with a brief operating instruction printed on the unit. It comes standard with a 10 meter rope and a shackle hook to be used for hanging the AIS-SART on the inside of a life raft.

Indicators:

Tron AIS-SART is equipped with two colored LEDs, one green and one red. The LEDs will give visual status of operation and faults. In addition a built in buzzer beeps regularly to indicate operation.

FUNCTION	INDICATOR	BUZZER
GPS position fix OK	Green LED flashes	Regularly beep
Searching for GPS fix	Red and Green LED flashes	Regularly beep
No GPS fix, count number of flashes.	Red LED flashes	Regularly beep

Table 1 Functions



www.jotron.com

1.2 BATTERY MODULE

The Battery Module comprises of two C-size Lithium batteries, a battery housing, a connector and cables. The battery module is to be replaced every 5th year. A battery expiry label on the Tron AIS-SART housing displays the expiry date.

Only original Jotron batteries, partno 82616, are allowed to be used with this product

A new battery comes complete with cable and connector.

Year							
2013	2014	2015	2016	2017	2018		
Battery Expiry							
1	Jotron Battery Type:				12		
2	X-82615				11		
3	4	5	6	7	8	9	10
Month							



2 TECHNICAL SPECIFICATIONS

2.1 ELECTRICAL SPECIFICATIONS

Frequency:	161.975MHz and 162.025MHz
Temperature range:	Operating: -20°C to +55°C
Storage:	-30°C to +70°C
Radiated power (e.i.r.p):	1W (30dBm \pm 3dB)
Antenna pattern:	Vertical polarization
Battery:	Two C-size SAFT LSH 14 light Lithium batteries, 5 years service life + 18 month storage (from date of manufacture)
Battery capacity:	96 hours operation when activated at -20°C 5 years storage

2.2 MECHANICAL SPECIFICATION

Materials used:

- Wall bracket (82756): ASA
- Housing (82738): PC GF10
- Lightcover (82739): PC
- Impact Ring (82740): TPE

Unit dimensions:

Max diameter:	89 mm
Length:	251 mm
Weight:	450g

Unit with standard storage bracket:

Max diameter:	90 mm
Length:	251 mm

3 FUNCTIONAL DESCRIPTION

3.1 GENERAL

Tron AIS-SART consists of a housing sealed at the lower end with a bottom lid and may be split into the following main parts:

1. Bottom lid.
2. Housing with Tron AIS-SART electronic assembly and battery module.
The housing is made of polycarbonate.
3. Base of antenna

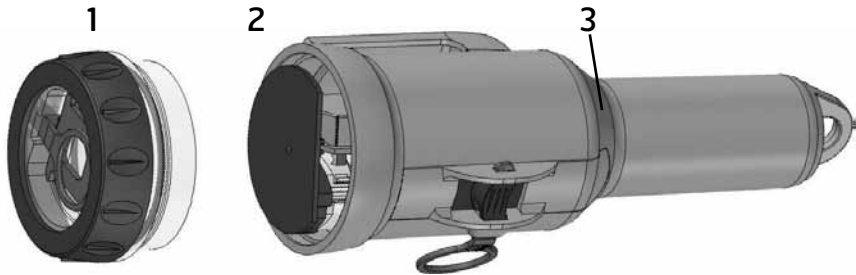

Figure 3.1, Tron AIS-SART disassembled

3.1.1 TRANSMITTER MODULE

Tron AIS-SART transmitter module is inserted into the Tron AIS-SART housing. It consists of the main board, antenna and two screen boxes which is mounted in the housing. It can be divided into the following sections:

1. Transmitter module
2. Antenna
3. Screen Boxes
4. Base of antenna

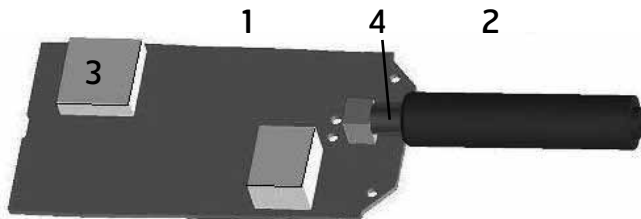

Figure 3.1.1 Tron AIS-SART Transmitter module



3.1.2 BATTERY MODULE (see page 26 for decription of battery change)

The battery module is inserted into the Tron AIS-SART housing.

A battery expiry label on the Tron AIS-SART housing displays the battery expiry date.

A new battery module comes complete with cable and connector and can be changed by opening the bottom lid at of the Tron AIS-SART.

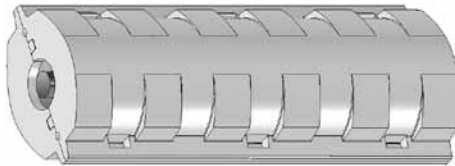

Figure 3.1.2 TRON AIS-SART BATTERY
- module without cable and connector



Battery expiry
label

3.1.3 BOTTOM LID

The Bottom lid includes four items:

1. The winder hook
2. The screw ring
3. The light tower
4. The O-ring

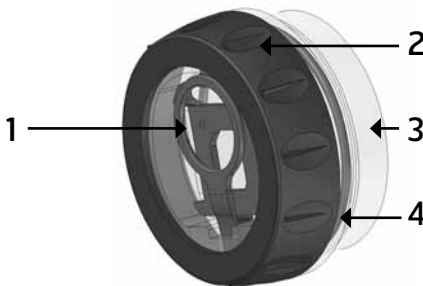

Figure 3.1.3 Bottom lid

4 INSTALLATION

Tron AIS-SART can be mounted several ways, depending on the options available. As a general rule, the transponder should be mounted as high as possible to increase line of sight to the search and rescue units.

Metal objects close to the transponder should be avoided, these will limit the performance in the directions they are located.

4.1 BRACKETS

There are two different mounting brackets available.

1. Wall bracket
2. Lifeboat bracket
3. Pole bracket

4.1.1 WALL BRACKET

A wall bracket is delivered with the Tron AIS-SART and should be used for storage of the unit. The bracket should preferably be mounted in a vertical position and in a place where the Tron AIS-SART is easily available in case of an emergency.

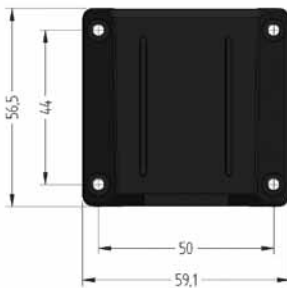

Figure 4.1.1a, wall bracket.

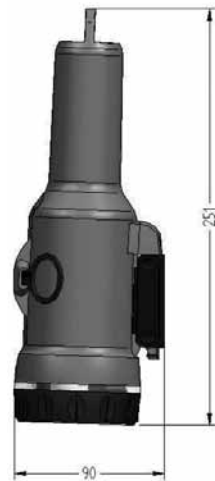

Figure 4.1.1b, Tron AIS-SART mounted in wall bracket.

The bracket should be mounted with four screws (\varnothing 4 mm).

4.1.2 LIFEBOAT BRACKET

The outdoor lifeboat bracket should be mounted vertically on the roof of the lifeboat (as high as possible).

Activate the unit and put it into the bracket. Secure the transponder to the bracket. The bracket will fit a pipe with a maximum diameter of 50mm.

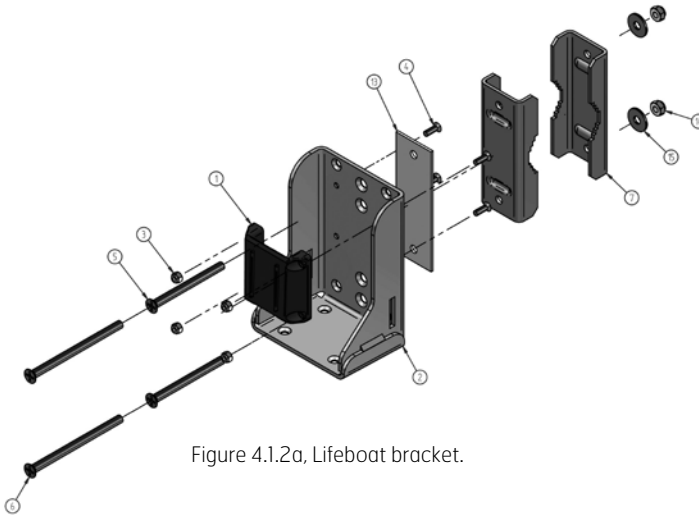

Figure 4.1.2a, Lifeboat bracket.

Item nr.	Document nr.	Title
1	M-82746	WALL BRACKET
2	M-84163_WELDAMENT	M-84163_BRACKET_UNIVERSAL_WELDAMENT D 1
3	M-80312	Nut nylock M4 DIN 985
4	M-84676	Screw, DIN965 - Pozidrive M4x12
5	M-84854	Screw, DIN965 - Pozidrive M6x70
6	M-84855	Screw, DIN965 - Pozidrive M6x90
7	M-84838	PIPE CLAMP
13	M-84875	WASHER PLATE
14	M-91469	Nut nylock M6 DIN 985
15	M-82275	WASHER, DIN9021 Ø6mm

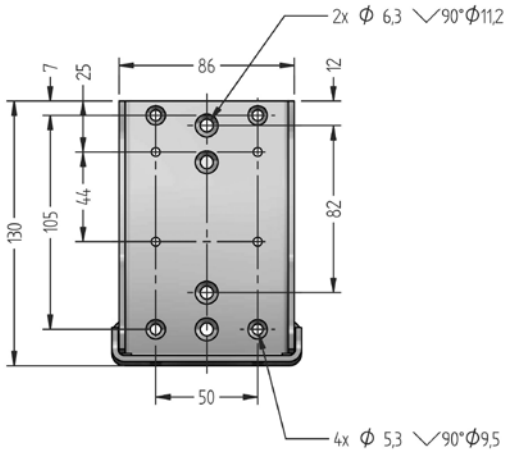

Figure 4.1.2b, Tron AIS-SART lifeboat bracket.



Figure 4.1.2c, AIS-SART to put into lifeboat bracket.

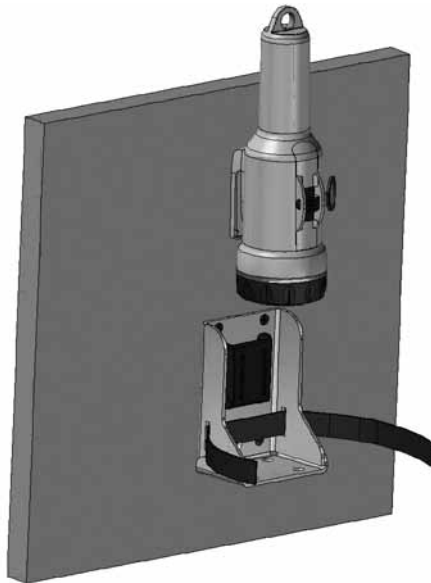

Figure 4.1.2d Example of Mounting the Bracket on Interior and Exterior Walls of a Lifeboat



4.2 INSTALLATION TIPS

4.2.1 HOW TO USE THE BRACKET IN LIFE RAFTS

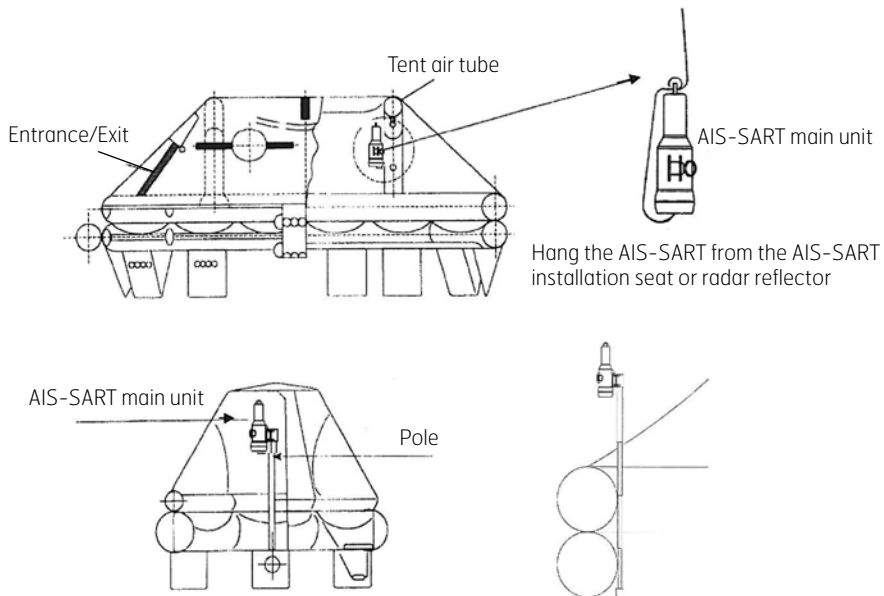

Figure 4.2.1, How to mount Tron AIS-SART to a liferaft

4.2.2 INSTALLATION DIAGRAM

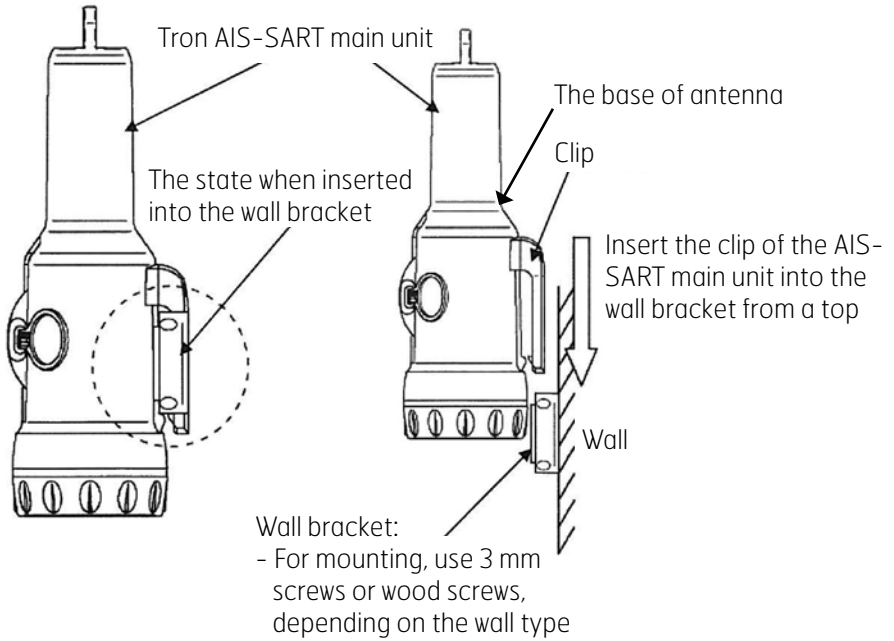

Figure 4.2.2, Installation diagram of the AIS-SART main unit and the wall bracket

4.2.3 MOUNTING TO A PIPE

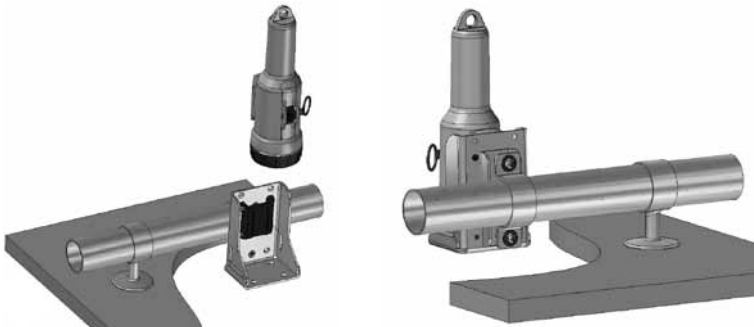

Figure 4.2.3a, Examples of pipe mounting

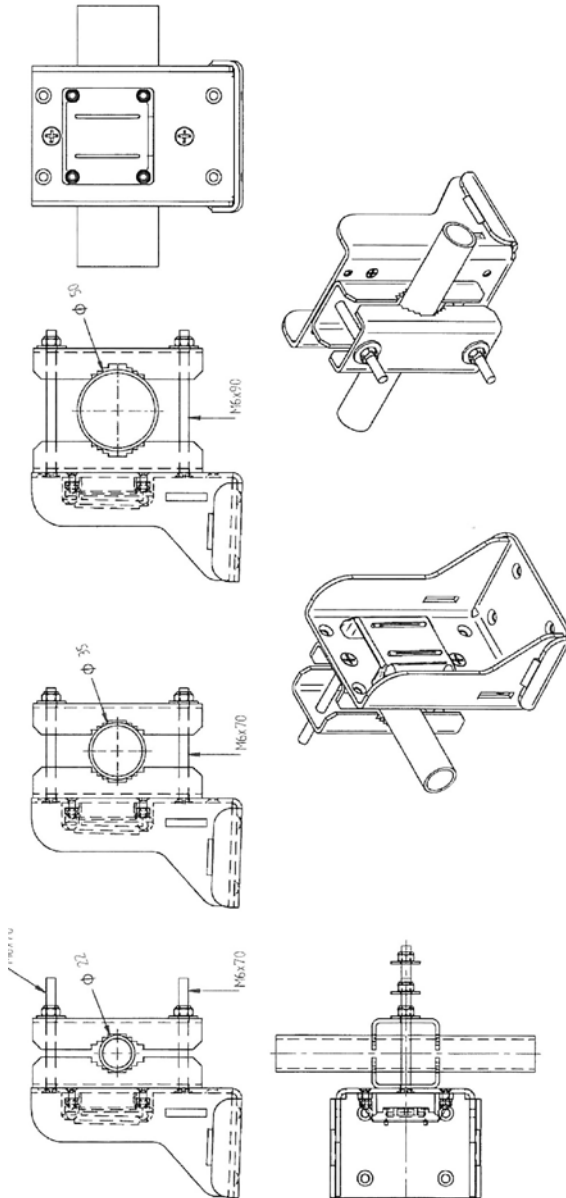

Figure 4.2.3b, Mounting to a pipe, example of reference



4.3 USING THE TELESCOPIC POLE



Figure 4.3. Tron AIS-SART with telescopic pole attached.

A telescopic pole can be used to extend the height of the Tron AIS-SART, inside or outside the life raft/boat. Simply extend the attached pole to the full length (app. 1,2m from the top of the Tron AIS-SART). Make sure that the rod is locked by pulling hard when it is fully extended. The rod can now be fastened or held by a person. Ensure the rod is held as vertical as possible when activating the Tron AIS-SART.



www.jotron.com

4.4 USING THE 10M ROPE

The 10m. rope is meant to hang the Tron AIS-SART inside a life raft. Any objects that the rope can be attached to can be used. As long as the AIS-SART is kept away from any metal objects, the performance will not be notably degraded because of the canvas of the life raft.



Figure 4.4, Tron AIS-SART with 10m rope attached.



5 OPERATING INSTRUCTIONS

5.1 ACTIVATION

1. Break seal at switch

2. Pull "Activation ring" to activate (see label) and make sure that the switch enters the "ON" position. The indicator LEDs will start to flash and an audible "BEEP" will be heard regularly.

3. After lifeboat/liferaft is launched,

Remove AIS-SART from bracket and mount it using:

- Lanyard (as described in 4.2.1/4.4) or
- Pole (as described in 4.2.1/ 4.3) or
- Lifeboat bracket (as described in 4.2.3) or
- Outdoor wall bracket (-" - 4.2.2)

With a clear view to the sky to maximize GPS location (Inside inflatable liferaft is also OK)

4. Tron AIS-SART will flash both LEDs (Green + Red) while it is searching for GPS position fix (max 15 minutes)

5. A BEEP will be heard every time a transmission is made (once a minute)

6. A successful GPS fix is indicated by **Green LED** flash

7. If no GPS fix is obtained, this is indicated with **RED LED** flash → Please relocate the unit and restart AIS-SART.

If the **Green LED** is flashing as indicated in (6.) the AIS -SART will update it's GPS position every minute and transmit it's new position to nearby ships (or rescue aircrafts).





5.2 RECEPTION ON NEARBY VESSELS AIS TRANSPONDERS AND ECS/ECDIS OR CHART PLOTTERS

Today, most AIS transponders installed are not compliant with AIS-SART, but will still receive them as another ship, both with ID code, Position, Range, Bearing, and Text message

5.2.1 RECEPTION ON A NON AIS-SART COMPLIANT AIS TRANSPONDER:

- will be shown as a ship without name, with MMSI (here "ID code"), range, bearing and position:

RNG	BRG	Name	1/2
> 0.01	222		
15	150	Havhesten	

> MMSI: 970010001	1/14
Call: ---	
ETA: --/-- 00:00n	

- Some AIS transponders will show MMSI (here "ID code") when no vessel name is received
- In addition, a text message will be received:

Menu Message	1/2
> 97001001:SART ACTIVE	

5.2.2 RECEPTION AN A NON AIS-SART COMPLIANT ELECTRONIC CHART (ECS/ECDIS):

- will be shown as a ship



- with the same text message received: **SART ACTIVE**

5.2.3. RECEPTION ON AN AIS-SART COMPLIANT AIS TRANSPONDER:

The requirement to have a AIS-SART compliant AIS transponder, is not ready yet, not when it will be implemented, nor what the final requirement will be. But there are drafts of new AIS specification, IEC 61993-2 (Ed.2) which states:

By default the target list is auto-sorted in ascending range except the nearest active AIS SART or, if supported, other target of interest shall be displayed at the top of the list.

- will be possibly be shown with the text “SART ACTIVE” as “vessel name” with range, bearing and position:

RNG	BRG	Name	1/2
> 0.01	222		
15	150	Havhesten	

> MMSI: 970010001	1/14
Call: ---	
ETA: --/-- 00:00n	

- In addition, a text message will be received:

Menu Message	1/2
> 97001001:SART ACTIVE	

5.2.4. RECEPTION ON AN AIS-SART COMPLIANT ELECTRONIC CHART (ECS/ECDIS):

Even though the AIS transponder is not AIS-SART compliant, the electronic chart may show the correct symbol when receiving an AIS-SART in “Test” or “Active” if it is updated to the latest revisions defined below:

- will be shown with this special symbol (red) as defined here: SN.1/Circ.243/Add.1 and in latest revision of IEC 62388:
- An AIS Search And Rescue Transponder (SART) shall be presented as a circle with an “X” inscribed inside it. The circle shall be 5 millimetres in diameter. The symbol shall be drawn using a thick dashed line style with the colour red. The symbol shall flash until acknowledged by the user. Once acknowledged, the symbol shall cease flashing.
- with the same text message received: **SART ACTIVE**





5.3 TEST

1. Test must be conducted outdoors with a clear view to the sky to maximize GPS location.

2. Move the switch to “TEST” position until the LEDs start flashing.

Tron AIS-SART will now run through a self test procedure. If a Red LED flashes, it is indication of critical faults. *See table below for error codes.



3. Release the switch when both LEDs start flashing. The unit will now search for GPS position for maximum 15 minutes.

4. A successful test is indicated by 15 second beep and Green LED. See next page for description of indication on a AIS transponder/ Electronic chart etc



5. An unsuccessful test is indicated by 15 second beep and Red LED. Please relocate the unit and restart test.

6. To cancel ongoing test, hold the switch on the Tron AIS-SART in the “TEST” position until the buzzer starts to beep.



*Error codes if RED flash in “2.”

Number of red LED flash	Fault indication
2	Transmit power failure
3	Low battery
4	Transmit frequency error
5	User ID not programmed
6	Undefined, contact Jotron
7	Internal communication error



5.4 RECEPTION ON NEARBY VESSELS AIS TRANSPONDERS AND ECS/ECDIS OR CHART PLOTTERS

To conduct a complete test of a Tron AIS-SART, reception on the ships AIS transponder should also be checked. Today, most AIS transponders installed are not compliant with AIS-SART, but will still receive them as another ship, both with ID code, Position, Range, Bearing, and Text message

5.4.1 RECEPTION AN A NON AIS-SART COMPLIANT AIS TRANSPONDER:

- will be shown as a ship without name, with MMSI (here "ID code"), range, bearing and position:

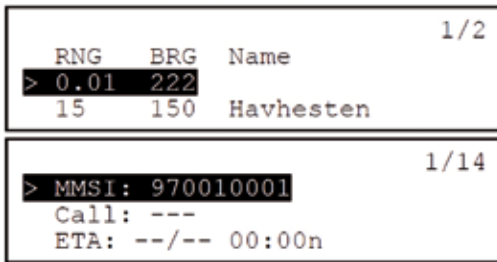

- Some AIS transponders will show MMSI (here "ID code") when no vessel name is received
- In addition, a text message will be received:

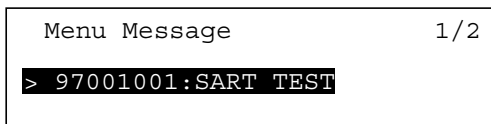

5.4.1 RECEPTION AN A NON AIS-SART COMPLIANT ELECTRONIC CHART (ECS/ECDIS):

- will be shown as a ship



- with the same text message received: **SART TEST**

5.4.3 RECEPTION AN A AIS-SART COMPLIANT AIS TRANSPONDER:

The requirement to have a AIS-SART compliant AIS transponder, is not ready yet, not when it will be implemented, nor what the final requirement will be. But there are drafts of new AIS specification, IEC 61993-2 (Ed.2) which states:

By default the target list is auto-sorted in ascending range except the nearest active AIS SART or, if supported, other target of interest shall be displayed at the top of the list.

In addition, there will be possibly automatic filtering of AIS SART's in TEST since the test will send text messages to all nearby ships (within VHF range). There are today two suggestions on how to implement the filtering:

1. Prior to test the AIS-SART on your own ship, you must enter "Configuration menu" of your own AIS transponder, and turn on "Show AIS-SART Test"
2. Only receive AIS-SART in "Test" within a very limited range
 - will be possibly be shown with the text "SART TEST" as "vessel name" with range, bearing and position:

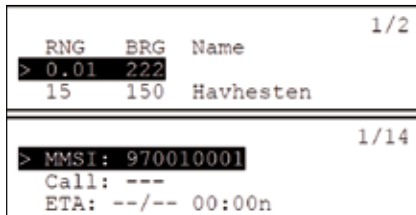

- In addition, a text message will be received:

5.4.3 RECEPTION AN A AIS-SART COMPLIANT ELECTRONIC CHART (ECS/ECDIS):

Even though the AIS transponder is not AIS-SART compliant, the electronic chart may show the correct symbol when receiving an AIS-SART in "Test" or "Active" if it is updated to the latest revisions defined below:

- will be shown with this special symbol as defined here: [SN.1/Circ.243/Add.1](#) and in lates revision of IEC 62388:
 - An AIS Search And Rescue Transponder (SART) shall be presented as a circle with an "X" inscribed inside it. The circle shall be 5 millimetres in diameter. The symbol shall be drawn using a thick dashed line style with the colour red. The symbol shall flash until acknowledged by the user. Once acknowledged, the symbol shall cease flashing.
- with the same text message received: **SART TEST**





www.jotron.com

6 MAINTENANCE AND TROUBLESHOOTING

6.1 MAINTENANCE

Tron AIS-SART requires the following maintenance:

Every month

The unit should be taken out of its bracket and tested using the procedure in chapter 5.1.

Every 5 years

The battery unit must be replaced every 5 year. Storage of batteries over a long period of time will reduce their capacity. To ensure long and reliable operation the battery unit must be replaced every 5 year. The battery replacement can be performed on board using the procedure in chapter 6.2.1.

6.2 SERVICE

Warranty Service

All goods sold by the Company are warranted to be free from defect in workmanship and material for the period of twenty-four (24) months from the date of delivery (unless stated otherwise and confirmed in writings). For further information, see pos.6 "Guarantee" in our Terms and Conditions of Sale.

Provided that the unit(s) returned for repair is under warranty, man-hour cost and material cost will be covered by Jotron. This is not valid if the customer has tried to repair, modify or rebuild the unit, or if the unit has been exposed to environmental conditions outside the specifications for the unit.

If the unit is in need of repair, please return it carriage paid to the agent that you purchased it from.

Additional costs not related to repair/replacement of the unit will not be covered.



6.2.1 REPLACING THE BATTERY MODULE

Below is a description on how to change batteries on AIS-SART

Dissassembly:



Twist the rubber grip anti-clockwise to remove the lid



It might be difficult to remove the lid. If so, remove the rubber grip first



And then twist off the lid



Opened



Rubber holder below battery and electronics removed



Pull out the battery



Pull out the cable from connector



Remove old Silaca gel bags



www.jotron.com

Assembly:



Install the new battery. Make sure the cable is within the guide



Connect cable to electronics, black= left, red= right



Add 2x5 g Silica gel bags



Mount rubber holder



Remove old O-ring using a Credit Card



Use acid-free Vaseline on the new O-ring



Fit the new O-ring



Reinstall lid- tighten without tools



Replace the rubber grip



Assembly completed



6.2.2 BATTERY DISPOSAL

Dispose in accordance with applicable regulations, which vary from country to country. (In most countries, the disposal of used batteries is regulated and end-users are invited to dispose of them correctly, through non-profit organizations, mandated by local governments or organized on a voluntary basis by professionals). Lithium batteries should have their terminals insulated prior to disposal.

6.2.3 INCINERATION

Incineration should never be performed by battery users but by trained professionals in authorized facilities with proper gas and fumes treatment.

6.2.4 LAND FILLING

Leachability regulations (mg/l)

Component	Leachability	EC limit	EPA	Other*
Iron	100			5
Nickel	100	500	2	0,5

* Applicable to France

6.2.5 RECYCLING

Send to authorized recycling facilities, through a licensed waste carrier.



www.jotron.com

7 SERVICE AGENTS

Please look at www.jotron.com for Marine Service Agents.

Jotron Group subsidiary companies:

Jotron UK Ltd.

Crosland Park
Cramlington
NE23 1LA
United Kingdom
Tel +44 1670 712000
Fax +44 1670 590265
E-mail: sales@jotron.com

Jotron Asia Pte. Ltd.

Changi Logistics Center
19 Loyang Way #04-26
Singapore 508724
Tel +65 65426350
Fax +65 65429415
E-mail: sales@jotron.com

Jotron USA, Inc.

10645 Richmond Avenue, Suite 140
Houston, TX 77042
USA
Tel +1 713 268 1061
Fax +1 713 268 1062
E-mail: sales@jotron.com

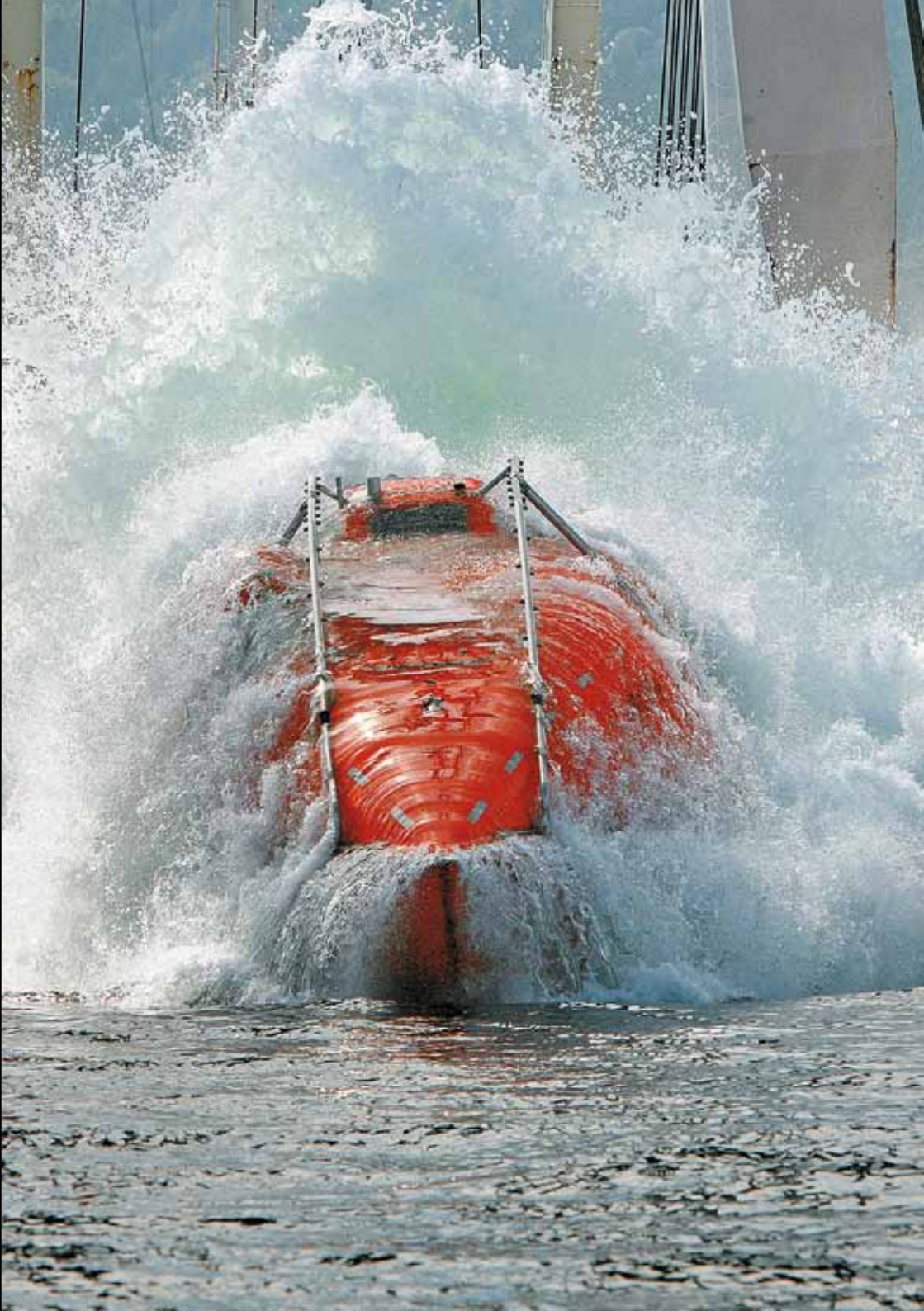



Jotron AS
Jotron UK Ltd.
Jotron Phontech AS
Jotron Consultas AS
Jotron Asia Pte. Ltd.
Jotron USA, Inc.
UAB Jotron



www.jotron.com