

Trapeze Mobility Point™

MP-620 Installation Guide



Part Number 730-9502-0062, Revision C

Trapeze Networks, Inc.
5753 W. Las Positas Blvd.
Pleasanton, CA 94588

Tel: +1 925-474-2200
Fax: +1 925-251-0642
Toll-Free: 877-FLY-TRPZ (877-359-8779)

www.trapezenetworks.com

© 2006 Trapeze Networks, Inc. All rights reserved.

Trademarks

Trapeze Networks, the Trapeze Networks logo, the Trapeze Networks flyer icon, Mobility System, Mobility Exchange, MX, Mobility Point, MP, Mobility System Software, MSS, RingMaster, AAA Integration and RADIUS Scaling, ActiveScan, AIRS, Bonded Auth, FastRoaming, Granular Transmit Power Setting, GTPS, GuestPass, Layer 3 Path Preservation, Location Policy Rule, LPR, Mobility Domain, Mobility Profile, Passport-Free Roaming, SentryScan, Time-of-Day Access, TDA, TAPA, Trapeze Access Point Access Protocol, Virtual Private Group, VPG, Virtual Service Set, Virtual Site Survey and WebAAA are trademarks of Trapeze Networks, Inc. Trapeze Networks SafetyNet is a service mark of Trapeze Networks, Inc. All other products and services are trademarks, registered trademarks, service marks or registered service marks of their respective owners.

Disclaimer

All statements, specifications, recommendations, and technical information are current or planned as of the date of the publication of this document. They are reliable as of the time of this writing and are presented without warranty of any kind, expressed or implied. In an effort to continuously improve the product and add features, Trapeze Networks reserves the right to change any specifications contained in this document without prior notice of any kind.

Comments and Feedback

Your feedback on Trapeze documentation is important to us. Send any comments and suggestions to doc-bugs@trapezenetworks.com.

For the most current version of this document, see www.trapezenetworks.com.



Note. The manufacturer is not responsible for any radio or TV interference caused by unauthorized modifications to this equipment. Such modifications could void the user's authority to operate the equipment.



Customer Service

For general information about Trapeze Networks Mobility System™ products and services, visit www.trapezenetworks.com. For warranty, license, and support information, visit the following sites:

- **Warranty and software licenses.** Current Trapeze Networks warranty and software licenses are available at www.trapezenetworks.com/services/warranty.asp.
- **Support services.** For information about Trapeze support services, visit www.trapezenetworks.com/services/. Or call 1-866-877-9822 (in the US or Canada) or +1 925-474-2400 and select option 5.



Note. TRAPEZE NETWORKS SELLS AND SERVICES ITS PRODUCTS PRIMARILY THROUGH ITS AUTHORIZED RESELLERS AND DISTRIBUTORS. If you purchased your product from an authorized Trapeze reseller or distributor and do not have a service contract with Trapeze Networks, you must contact your local reseller or distributor for technical assistance.

Contacting the Technical Assistance Center

Contact the Trapeze Networks Technical Assistance Center (TAC) by telephone, email, or fax. If you have a service contract or are a Trapeze Authorized Partner, log in to www.trapezenetworks.com/services/sup_programs.asp for more help.

- Within the US and Canada, call 1-866-TRPZTAC (1-866-877-9822).
- Within Europe, call +31 35 64 78 193.
- From locations outside the US and Canada, call +1 925-474-2400.
- In non-emergencies, send email to support@trapezenetworks.com.
- When your case is active, you can fax more information to +1 925-474-2423.



TAC Response Time

TAC responds to service requests as follows:

Contact method	Priority	Response time
Telephone	Emergency	One hour
	Non-emergency	Next business day
Email	Non-emergency	Next business day

Information to Have Available

To expedite your service request, have the following information available when you call or write to TAC for technical assistance:

- Your company name and address
- Your name, telephone number, cell phone or pager number, and email address
- Name, model, and serial number of the product(s) requiring service
- Software version and release number
- Output of the **show tech-support** command
- Wireless client information
- License levels for RingMaster™ and Mobility Exchange™ (MX™) products
- Description of the problem and status of the troubleshooting effort



Contents

Customer Service	iii
1 Introducing the Trapeze Networks Mobility System	1
Trapeze Networks Mobility System	1
Documentation	2
Safety and Advisory Notices	4
Text and Syntax Conventions	5
2 MP-620 Overview	7
Hardware Overview	8
Package Checklist	8
External Hardware Features	9
External Antenna Options	9
Ethernet Port	10
Power Injector Module	11
Receive Signal Strength Indicator (RSSI) BNC Connector	12
Grounding Point	12
Wall- and Pole-Mounting Bracket Kits	12
Lightning Protector for Outdoor Antenna	12
System Configuration	12
Features and Benefits	13
3 Installing and Connecting an MP-620 Access Point	15
Installation Requirements and Recommendations	15
RingMaster Network Plan and Work Orders	15
MX Switch Recommendation	16
Weather Conditions	16
Ethernet Cabling	17
Grounding	17
MP Radio Safety Advisories	18
Radio Frequency Exposure	18



Additional Radio Safety Advisories	18
Installing an MP-620	19
Mounting the Unit	19
Using the Pole-Mounting Bracket	19
Using the Wall-Mounting Bracket	21
Connecting External Antennas	21
Connecting Cables to the Unit	23
Connecting the Power Injector	24
Connecting an MP to an MX Switch	25
A MP-620 Technical Specifications	29
MP-620 Mechanical and Compliance Specifications	30
Federal Communication Commission Interference Statement	31
MAC Addresses	33
Antenna Specifications	34
8 dBi Omnidirectional (2.4 GHz)	34
8 dBi Omnidirectional (5 GHz)	36
13.5 dBi 120-Degree Sector	37
10 dBi 120-Degree Sector	38
18 dBi 18-Degree Panel	40
Signal Loss from Lightning Protector and Coaxial Cable	41
B Cables and Pinouts	43
Twisted-Pair Cable Assignments	43
10/100BASE-TX Pin Assignments	44
Straight-Through Wiring	45
Crossover Wiring	45
8-Pin DIN Connector Pinout	46
8-Pin DIN to RJ-45 Cable Wiring	47
Index	49



Introducing the Trapeze Networks Mobility System

Trapeze Networks Mobility System	1
Documentation	2

This guide shows you how to install a Trapeze Networks™ Mobility Point™ (MP™) access point, model MP-620, in a Trapeze Networks Mobility System™ wireless LAN (WLAN). The MP-620 is suitable for installation outdoors.

Read this guide if you are a network administrator or other person installing MP access points in a network.

Trapeze Networks Mobility System

The Trapeze Networks Mobility System is an enterprise-class WLAN solution that seamlessly integrates with an existing wired enterprise network. The Trapeze system provides secure connectivity to both wireless and wired users in large environments such as office buildings, hospitals, and university campuses.

The Trapeze Mobility System fulfills the three fundamental requirements of an enterprise WLAN: it eliminates the distinction between wired and wireless networks, allows users to work safely from anywhere (*secure mobility*), and provides a comprehensive suite of intuitive tools for planning and managing the network before and after deployment, greatly easing the operational burden on IT resources.



The Trapeze Networks Mobility System consists of the following components:

- **RingMaster tool suite**—A full-featured graphical user interface (GUI) application used to plan, configure, deploy, and manage a WLAN and its users
- **One or more Mobility Exchange™ (MX™) switches**—Distributed, intelligent machines for managing user connectivity, connecting and powering Mobility Point (MP) access points, and connecting the WLAN to the wired network backbone
- **Multiple Mobility Point™ (MP™) access points**—Wireless access points (APs) that transmit and receive radio frequency (RF) signals to and from wireless users and connect them to an MX switch
- **Mobility System Software™ (MSS™)**—The operating system that runs all MX switches and MP access points in a WLAN, and is accessible through a command-line interface (CLI), the Web View interface, or the RingMaster GUI

Documentation

Consult the following documents to plan, install, configure, and manage a Trapeze Networks Mobility System.

Planning, Configuration, and Deployment

Trapeze RingMaster User's Guide. Instructions for planning, configuring, deploying, and managing the entire WLAN with the RingMaster tool suite. Read this guide to learn how to plan wireless services, how to configure and deploy Trapeze equipment to provide those services, and how to optimize and manage your WLAN.

Trapeze RingMaster Reference Manual. Detailed instructions and information for all RingMaster planning, configuration, and management features.

Installation

- *Trapeze Mobility Exchange Hardware Installation Guide*. Instructions and specifications for installing an MX switch
- *Trapeze Mobility System Software Quick Start Guide*. Instructions for performing basic setup of secure (802.1X) and guest (WebAAA™) access, and for configuring a Mobility Domain for roaming
- *Trapeze Mobility Point MP-372 Installation Guide*. Instructions and specifications for installing an MP access point and connecting it to an MX switch
- *Trapeze Mobility Point MP-620 Installation Guide* (this document). Instructions and specifications for installing the MP-620 access point and connecting it to an MX switch
- *Trapeze Regulatory Information*. Important safety instructions and compliance information that you must read before installing Trapeze Networks products

Configuration and Management

- *Trapeze RingMaster Reference Manual*. Instructions for planning, configuring, deploying, and managing the entire WLAN with the RingMaster tool suite
- *Trapeze Mobility System Software Configuration Guide*. Instructions for configuring and managing the system through the MSS CLI
- *Trapeze Mobility System Software Command Reference*. Functional and alphabetic reference to all MSS commands supported on MX switches and MP access points



Safety and Advisory Notices

The following kinds of safety and advisory notices appear in this manual. (For translations of the warning conventions and of all warnings in this manual, see the *Trapeze Regulatory Information* document.)



Caution! This situation or condition can lead to data loss or damage to the product or other property.



Warning! This situation or condition can cause injury.



Warning! High voltage. This situation or condition can cause injury due to electric shock.



Warning! Radiation. This situation or condition can cause injury due to improper handling of fiber-optic equipment.



Note. This information is of special interest.

Text and Syntax Conventions

Trapeze manuals use the following text and syntax conventions:

Convention	Use
Monospace text	Sets off command syntax or sample commands and system responses.
Bold text	Highlights commands that you enter or items you select.
<i>Italic text</i>	Designates command variables that you replace with appropriate values, or highlights publication titles or words requiring special emphasis.
Menu Name > Command	Indicates a menu item that you select. For example, File > New indicates that you select New from the File menu.
[] (square brackets)	Enclose optional parameters in command syntax.
{ } (curly brackets)	Enclose mandatory parameters in command syntax.
(vertical bar)	Separates mutually exclusive options in command syntax.





MP-620 Overview

Hardware Overview	8
External Hardware Features	9
System Configuration	12
Features and Benefits	13

A Trapeze Networks Mobility Point (MP) access point model MP-620 provides IEEE 802.11 wireless access to the network. MP access points are designed for use with a Trapeze Networks Mobility Exchange (MX) switch. MP access points require hardware installation only. All configuration for an MP access point takes place on the MX switch.



Warning! Installation must be performed by qualified service personnel only. Read and follow all warning notices and instructions marked on the product or included in the documentation. Before installing the product, read the [Trapeze Regulatory Information](#) document.



Note. The MP radios are disabled by default and can be enabled only by a system administrator using the MX switch.

Hardware Overview

The MP-620 provides wireless access point services for clients in the local LAN area. It is housed in a weatherproof enclosure for mounting outdoors and includes its own brackets for attaching to a wall, pole, radio mast, or tower structure. The unit is powered through its Ethernet cable connection from a power injector module that is installed indoors.

Radio Characteristics – The IEEE 802.11a and 802.11g standards use a radio modulation technique known as Orthogonal Frequency Division Multiplexing (OFDM), and a shared collision domain (CSMA/CA). The 802.11a standard operates in the 5 GHz Unlicensed National Information Infrastructure (UNII) band, and the 802.11g standard in the 2.4 GHz band.

IEEE 802.11g includes backward compatibility with the IEEE 802.11b standard. IEEE 802.11b also operates at 2.4 GHz, but uses Direct Sequence Spread Spectrum (DSSS) and Complementary Code Keying (CCK) modulation technology to achieve a communication rate of up to 11 Mbps.

The MP-620 provides a 54 Mbps half-duplex connection for each active channel.

Package Checklist

The MP-620 package includes:

- One MP-620 Mobility Point (MP) access point
- One Category 5 network cable, length 164 ft (50 m)
- One power injector module and power cord
- Outdoor pole-mounting bracket kit
- This User Guide
- Optional: Two N-type RF coaxial cables
- Optional: Outdoor wall-mounting bracket kit
- Optional: Lightning protector for outdoor antenna

Contact Trapeze Networks if there are any incorrect, missing or damaged parts. If possible, retain the carton, including the original packing materials. Use them again to repack the product in case there is a need to return it.



External Hardware Features

Figure 1 and Figure 2 show the external hardware features of the MP-620.

Figure 1. MP Access Point Model MP-620—Bottom View

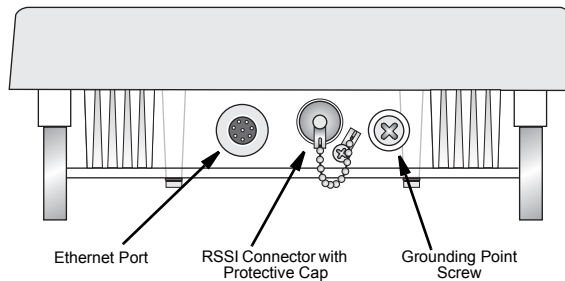
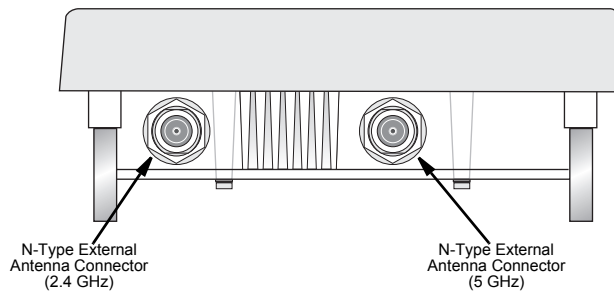

Figure 2. MP Access Point Model MP-620—Top View



External Antenna Options

The MP-620 unit does not include an integrated antenna, but provides various external antenna options for both 5 GHz and 2.4 GHz operation. The MP-620 unit both requires the 2.4 GHz 8 dBi omnidirectional external antenna for 2.4 GHz operation. The following table summarizes the external antenna options:

Table 1. External Antenna Options

Antenna Type	Gain (dBi)	HPBW* Horizontal	HPBW* Vertical	Polarization
5 GHz Omnidirectional	8	360	12	Linear, vertical
5 GHz 120-Degree Sector	13.5	120	6	Linear, vertical
5 GHz 18-Degree Panel	18	18	18	Linear, vertical
2.4 GHz 120-Degree Sector	10	120	15	Linear, vertical
2.4 GHz Omnidirectional	8	360	15	Linear, vertical

* Half-power beam width in degrees

External antennas connect to the N-type RF connectors on the MP-620 using the provided coaxial cables.

Ethernet Port

The MP-620 has one 10BASE-T/100BASE-TX 8-pin DIN port that connects to the power injector module using the included Ethernet cable. The Ethernet port connection provides power to the MP-620 as well as a data link to the local network.



Note. The power injector module does not support Power over Ethernet (PoE) based on the IEEE 802.3af standard. The MP-620 must always be powered on by being connected to the power injector module.

Power Injector Module

The MP-620 receives power through its network cable connection using power-over-Ethernet technology. A power injector module is included in the MP-620 package and provides two RJ-45 Ethernet ports, one for connecting to the MP-620 (Output), and the other for connecting to an MX switch or a local LAN switch (Input).

The Input port uses an MDI (i.e., internal straight-through) pin configuration. You can therefore use straight-through twisted-pair cable to connect this port to most network interconnection devices such as a switch or router that provide MDI-X ports. However, when connecting the access point to a workstation or other device that does not have MDI-X ports, you must use crossover twisted-pair cable.

Figure 3. Power Injector Module

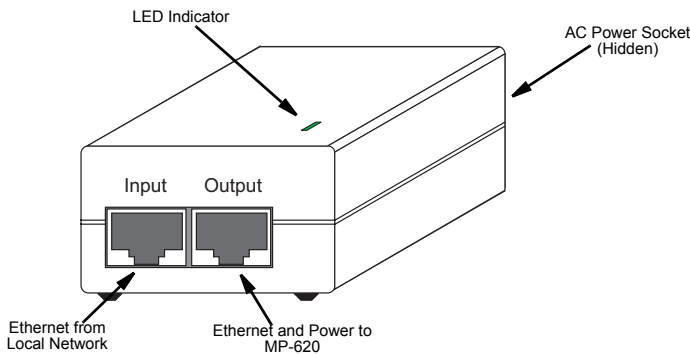

The MP-620 does not have a power switch. It is powered on when its Ethernet port is connected to the power injector module, and the power injector module is connected to an AC power source. The power injector includes one LED indicator that turns on when AC power is applied.

The power injector module automatically adjusts to any AC voltage between 100-240 volts at 50 or 60 Hz. No voltage range settings are required.



Warning! The power injector module is designed for indoor use only. Never mount the power injector outside with MP-620 unit.

Receive Signal Strength Indicator (RSSI) BNC Connector

This connector is unused at this time.

Grounding Point

Even though the MP-620 includes its own built-in lightning protection, it is important that the unit is properly connected to ground. A grounding screw is provided for attaching a ground wire to the unit.

Wall- and Pole-Mounting Bracket Kits

The MP-620 includes bracket kits that can be used to mount the unit to a wall, pole, radio mast, or part of a tower structure.

Lightning Protector for Outdoor Antenna

If you are using the MP-620 with an outdoor antenna, Trapeze Networks recommends installing an external lightning protector for the antenna.

System Configuration

At each location where an MP-620 unit is installed, it must be connected to the local network using the power injector module. The following figure illustrates the system component connections.

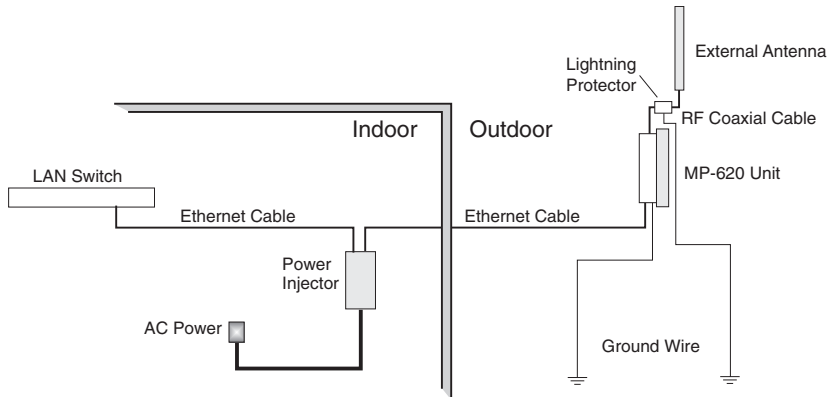
Figure 4. System Component Connections

Features and Benefits

The MP-620 provides the following features and benefits:

- The MP-620 supports access point services for the 5 GHz and 2.4 GHz radios using various external antenna options
- Maximum data rate up to 108 Mbps on the 802.11a (5 GHz) radio
- Outdoor weatherproof design
- IEEE 802.11a and 802.11b/g compliant
- Local network connection via 10/100 Mbps Ethernet port
- Powered through its Ethernet cable connection to the power injector module
- Includes wall- and pole-mount brackets
- Security through 64/128/152-bit Wired Equivalent Protection (WEP) or 128-bit Advanced Encryption Standard (AES) encryption
- Scans all available channels and selects the best channel and data rate based on the signal-to-noise ratio



Installing and Connecting an MP-620 Access Point

Installation Requirements and Recommendations	15
Installing an MP-620	19
Connecting an MP to an MX Switch	25



Note. Before installing an MP access point, you might need to generate a network plan and an MP work order with RingMaster. (See “RingMaster Network Plan and Work Orders” on page 15.)

Installation Requirements and Recommendations

For best results, follow these requirements and recommendations before installing an MP-620 access point.

RingMaster Network Plan and Work Orders

If you are using RingMaster to plan your Trapeze Networks Mobility System installation, you might want to create and verify a network plan for the entire Trapeze network installation and generate an MP work order, before installing MP access points. A network plan and the MP work orders generated from it provide the following information about MP access point installation and configuration:



- Number of MP access points required for adequate WLAN capacity in each coverage area
- Detailed installation location for each MP access point
- Settings for all MP access points in the WLAN

(For information about installing RingMaster, creating and verifying a network plan, and generating an MP work order, see the [Trapeze RingMaster User's Guide](#) and [Trapeze RingMaster Reference Manual](#).)

MX Switch Recommendation

Trapeze Networks recommends that you install and configure the MX switch before installing an MP access point. If the switch is already installed and configured for the MP access point(s), you can immediately verify the cable connection(s) when you plug the cable(s) into the MP access point.



Caution! MP model MP-620 is designed to receive power only from a Trapeze-approved power injector. Connecting an MP access point to a Power over Ethernet (PoE) device that is not approved by Trapeze Networks can damage the equipment.

(For information about connecting an MP access point to an MX switch port, see “Connecting an MP to an MX Switch” on page 25.)

Weather Conditions

When planning an MP-620 installation, you must take into account any extreme weather conditions that are known to affect your location. Consider these factors:

- **Temperature** — The MP-620 is tested for normal operation in temperatures from -33°C to 55°C. Operating in temperatures outside of this range may cause the unit to fail.
- **Wind Velocity** — The MP-620 can operate in winds up to 90 MPH and survive higher wind speeds up to 125 MPH. You must consider the known maximum wind velocity and direction at the site and be sure that any supporting structure, such as a pole, mast, or tower, is built to withstand this force.



- **Lightning** — The MP-620 includes its own built-in lightning protection. However, you should make sure that the unit, any supporting structure, and cables are all properly grounded. Additional protection using lightning rods, lightning arrestors, or surge suppressors may also be employed.
- **Rain** — The MP-620 is weatherproofed against rain. Also, prolonged heavy rain has no significant effect on the radio signal. However, it is recommended to apply weatherproof sealing tape around the Ethernet port and antenna connectors for extra protection. If moisture enters a connector, it may cause a degradation in performance.
- **Snow and Ice** — Falling snow, like rain, has no significant effect on the radio signal. However, a build up of snow or ice on antennas may cause a degradation in performance. In this case, the snow or ice has to be cleared from the antennas to restore proper operation of the unit.

Ethernet Cabling

When you have determined a suitable location for the MP-620, you must plan a cable route from the MP-620 outdoors to the power injector module indoors. Consider these points:

- The Ethernet cable length should never be longer than 100 m (328 ft)
- Determine a building entry point for the cable
- Determine if conduits, bracing, or other structures are required for safety or protection of the cable
- For lightning protection at the power injector end of the cable, consider using a lightning arrestor immediately before the cable enters the building

Grounding

It is important that the MP-620 unit, cables, lightning protectors, and any supporting structures are properly grounded. The MP-620 unit includes a grounding screw for attaching a ground wire. Be sure that grounding is available and that it meets local and national electrical codes.



MP Radio Safety Advisories

When you enable the MP radio(s) as part of MX switch configuration, the radios are able to receive and transmit radio frequency energy as soon as you connect the MP access point(s) to the MX switch, either directly or through the network.

Radio Frequency Exposure

Federal Communications Commission (FCC) Docket 96-8 for Spread Spectrum Transmitters specifies a safety standard for human exposure to radio frequency electromagnetic energy emitted by FCC-certified equipment. When used with the proper antennas (shipped in the product), Trapeze Networks MP access point products meet the uncontrolled environmental limits found in OET-65 and ANSI C95.1-1991. Proper installation of the MP access point according to the instructions in this manual will result in user exposure that is below the FCC recommended limits.

Additional Radio Safety Advisories

For additional radio safety warnings, the Trapeze Regulatory Information document.



Installing an MP-620

The MP-620 includes its own bracket kit for mounting the unit to a 1.5 to 2 inch diameter steel pole or tube. The pole-mounting bracket allows the unit to be mounted to part of a radio mast or tower structure. The unit also has a wall-mounting bracket kit that enables it to be fixed to a building wall or roof when using external antennas.

Hardware installation of the MP-620 involves these steps:

- 1 Mount the unit on a wall, pole, mast, or tower using the mounting bracket.
- 2 Mount external antennas on the same supporting structure as the MP-620 and connect them to the unit.
- 3 Connect the Ethernet cable and a grounding wire to the unit.
- 4 Connect the power injector to the Ethernet cable, a local LAN switch, and an AC power source.

Mounting the Unit

You can mount the MP-620 using either the pole-mounting bracket or the wall-mounting bracket. Use one of the following procedures.

Using the Pole-Mounting Bracket

Perform the following steps to mount the unit to a 1.5 to 2 inch diameter steel pole or tube using the mounting bracket:

- 1 Always attach the bracket to a pole with the open end of the mounting grooves facing up.
- 2 Place the U-shaped part of the bracket around the pole and tighten the securing nut just enough to hold the bracket to the pole. (The bracket may need to be rotated around the pole during the alignment process.)



Figure 5. Attaching the Bracket to the Pole

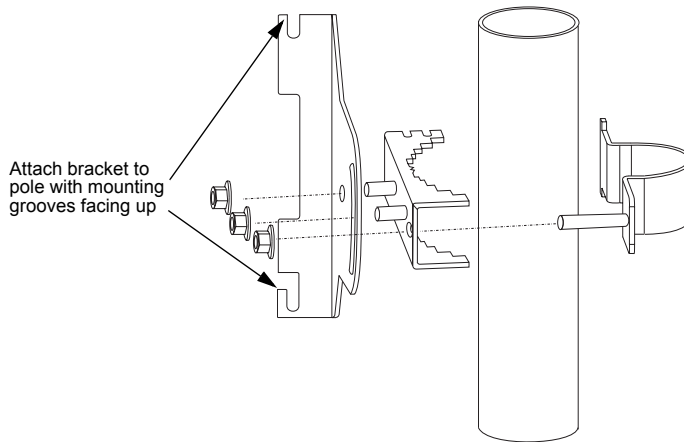

- 3 Use the included nuts to tightly secure the MP-620 to the bracket.

Mounting on Larger Diameter Poles

In addition, there is a method for attaching the pole-mounting bracket to a pole that is 2 to 5 inches in diameter using an adjustable steel band clamp (not included in the kit). A steel band clamp up to 0.5 inch (1.27 cm) wide can be threaded through the main part of the bracket to secure it to a larger diameter pole without using the U-shaped part of the bracket. This method is illustrated in the following figure.

Figure 6. Attaching the Bracket Using a Steel Band Clamp

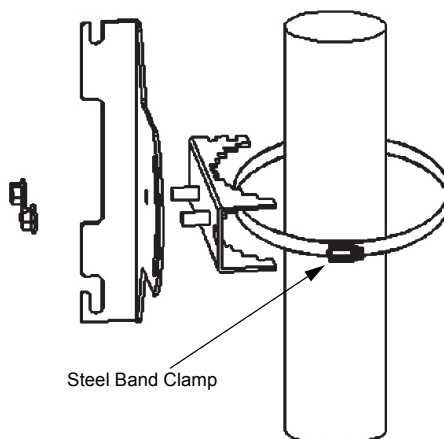

Using the Wall-Mounting Bracket

Perform the following steps to mount the unit to a wall using the wall-mounting bracket:

- 1 Always attach the bracket to a wall with the open end of the mounting grooves facing up (see following figure).

Figure 7. Wall-Mounting Bracket

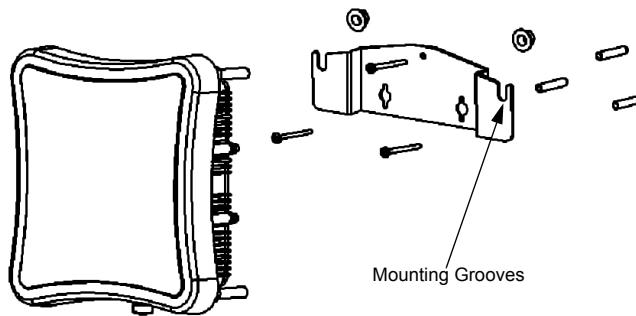

- 2 Position the bracket in the intended location and mark the position of the three mounting screw holes.
- 3 Drill three holes in the wall that match the screws and wall plugs included in the bracket kit, then secure the bracket to the wall.
- 4 Use the included nuts to tightly secure the MP-620 to the bracket.

Connecting External Antennas

When deploying an MP-620 access point, you need to mount external antennas and connect them to the unit. Typically, access point operation requires a 2.4 GHz antenna.

Perform these steps:

- 1 Mount the external antenna to the same supporting structure as the MP-620, within 3 m (10 ft) distance, using the bracket supplied in the antenna package.
- 2 If you are installing the optional lightning protector for an outdoor antenna, perform the following steps. Otherwise, skip to step 3.



- a** Solder the grounding cable to the grounding nut supplied with the lightning protector. Trapeze Networks recommends that you use 6-gauge cable for the grounding cable. The grounding cable must be properly earthed in order to provide adequate protection.
- b** Attach the grounding nut, locking washer, and hex nut to the lightning protector, in the order shown in Figure 8.

Figure 8. Attaching the Grounding Nut, Locking Washer, and Hex Nut to the Optional Lightning Protector

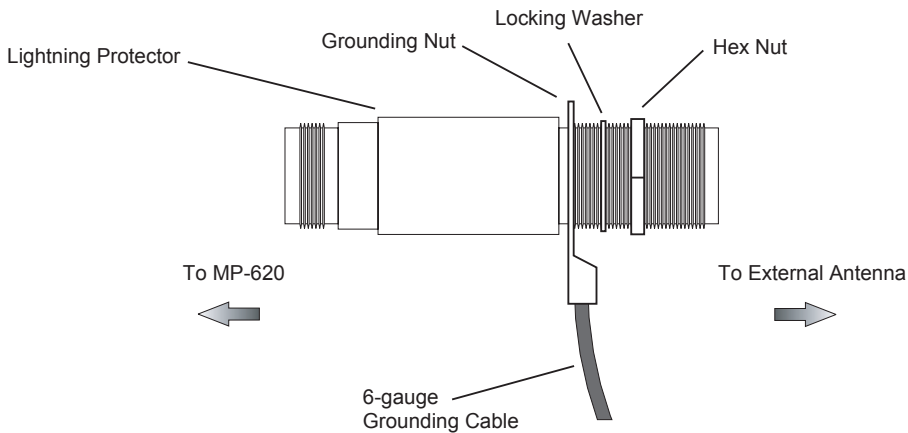

- c** Connect one end of the short RF coaxial cable to the MP-620's N-type connector, and connect the other end to the lightning protector.
 - d** Connect one end of the 3m RF coaxial cable to the lightning protector, and connect the other end to the outdoor antenna. Continue with step 4.
- 3** Connect the antenna to the MP-620's N-type connector using the RF coaxial cable provided in the antenna package.
 - 4** Apply weatherproofing tape to the antenna connectors to help prevent water entering the connectors.

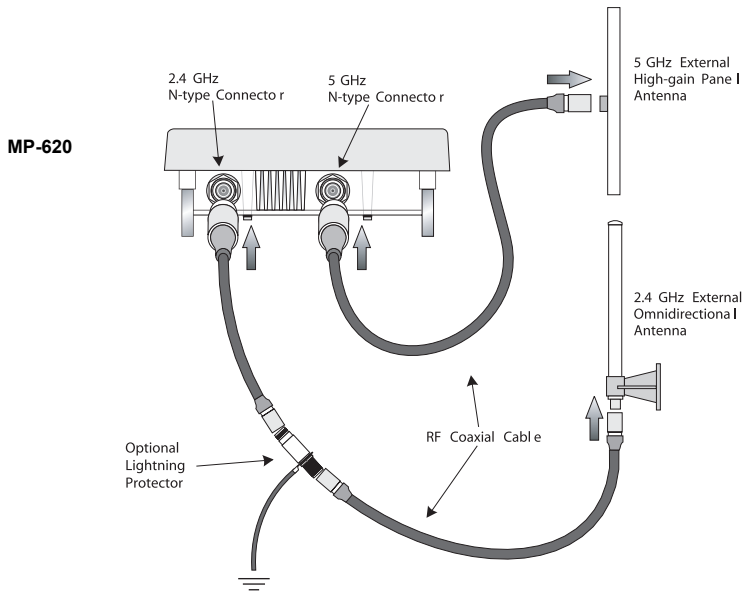
Figure 9. Connecting External Antennas to the MP-620

Connecting Cables to the Unit

- 1 Attach the Ethernet cable to the Ethernet port on the MP-620.



Note. The Ethernet cable included with the package is 30 m (100 ft) long. To wire a longer cable (maximum 100 m, 325 ft), use the connector pinout information in Appendix B.

- 2 For extra protection against rain or moisture, apply weatherproofing tape (not included) around the Ethernet connector.
- 3 Be sure to ground the unit with an appropriate grounding wire (not included) by attaching it to the grounding screw on the unit.



Caution! Be sure that grounding is available and that it meets local and national electrical codes. For additional lightning protection, use lightning rods, lightning arrestors, or surge suppressors.

Figure 10. Attaching an Ethernet Cable to the MP-620

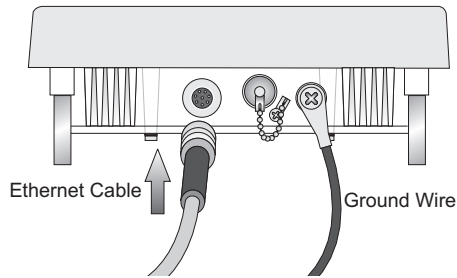

Connecting the Power Injector

To connect the MP-620 to a power source:



Caution! Do not install the power injector outdoors. The unit is for indoor installation only.



Note. The MP-620's Ethernet port does not support Power over Ethernet (PoE) based on the IEEE 802.3af standard. Do not try to power the unit by connecting it directly to a network switch that provides IEEE 802.3af PoE. Always connect the unit to the included power injector module.

- 1 Connect the Ethernet cable from the MP-620 to the RJ-45 port labeled "Output" on the power injector.
- 2 Connect a straight-through unshielded twisted-pair (UTP) cable from a local LAN switch to the RJ-45 port labeled "Input" on the power injector. Use Category 5 or better UTP cable for 10/100BASE-TX connections.

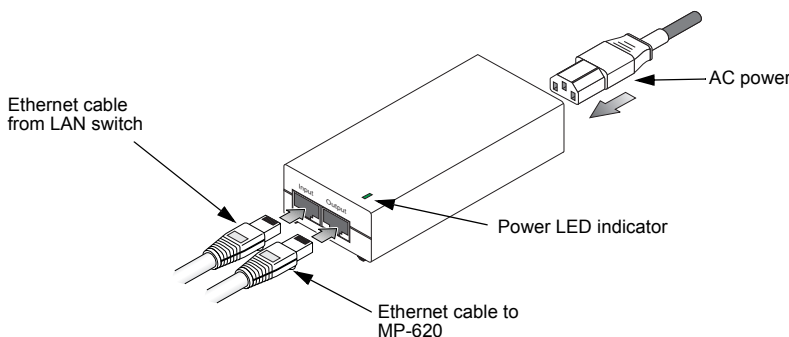

Note. The RJ-45 port on the power injector is an MDI port. If connecting directly to a computer for testing the link, use a crossover cable.

Figure 11. Connecting Cables to the Power Injector

- 3 Insert the power cable plug directly into the standard AC receptacle on the power injector.
- 4 Plug the other end of the power cable into a grounded, 3-pin socket, AC power source.



Note. For International use, you may need to change the AC line cord. You must use a line cord set that has been approved for the receptacle type in your country.

- 5 Check the LED on top of the power injector to be sure that power is being supplied to the MP-620 through the Ethernet connection.

Connecting an MP to an MX Switch

You can connect an MP access point directly to an MX switch or indirectly to the switch through an intermediate Layer 2 or Layer 3 network.

- To connect the MP directly to an MX switch, configure the MX switch port as an MP access port and use the following procedure to insert the cable into the MX switch and verify the link.
- To connect the MP indirectly to an MX switch through the network, configure a Distributed MP connection on the MX switch.

You can use the CLI or RingMaster to configure an MP access port or Distributed MP connection. (See the *Trapeze Mobility System Software Configuration Guide* or the *Trapeze RingMaster User's Guide*.)

Figure 12 shows how to insert a Cat 5 cable into 10/100 Ethernet port on an MX switch. Refer to this figure as you perform the procedure.

Figure 12. 10/100 Cat 5 Cable Installation

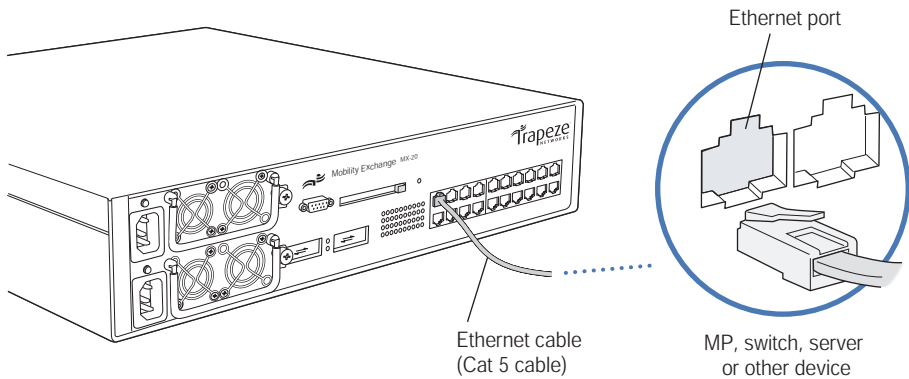

- 1 Insert a Cat 5 cable with a standard RJ-45 connector as shown in Figure 12. For connection to an MP access point, use a straight-through cable.
- 2 When the link is activated, observe the MP LED for the port on the MX switch:

MX Switch's MP LED**Meaning**

Solid green

For an MP access point's active link, all the following are true:

- MP access point has booted.
- MP access point has received a valid configuration from the MX switch.
- Management link with an MP access point is operational.
- At least one radio is enabled or is in sentry mode.

For an MP access point's secondary link, the link is present.

Alternating green and amber

MP access point is booting with an image received from the MX switch. After the access point boots and receives its configuration, this LED appearance persists until a radio is enabled or is placed in sentry mode.

Solid amber

PoE is on.

Blinking amber

MP is unresponsive or there is a PoE problem.

Unlit

PoE is off.



Note. An MX switch's 10/100 Ethernet ports are configured as wired network ports by default. You or the system administrator must change the port type for an MX port directly connected to an MP to activate the link. (See the [Trapeze Mobility Exchange Installation and Basic Configuration Guide](#).)



MP-620 Technical Specifications

This appendix lists the technical specifications for the Trapeze Networks MP-620 access point. Table 2 lists the mechanical and compliance specifications. (For detailed compliance information, see the *Trapeze Regulatory Information* document.) Table 3 lists the MAC address allocation scheme. The remaining tables list the specifications and link budgets for the external antennas.

(For specifications for the MX switch, see the *Trapeze Mobility Exchange Installation and Basic Configuration Guide*.)



Note. This Listed Accessory is designed and approved to be used only with Trapeze Networks Mobility Exchange (MX) models MX-20, MX-8, MX-216, and MXR-2. (The MX-200 and MX-400 switches do not directly connect to the MP.)



Note. The MP radios are disabled by default and can be enabled only by the system administrator using the RingMaster management application or the MX switch's command-line interface (CLI).



Note. The radio frequency band, operating channels, and transmit power depend on the country of operation specified by the system administrator using RingMaster or the MX switch's CLI.

MP-620 Mechanical and Compliance Specifications

Table 2 lists the mechanical and compliance specifications for the MP-620.

Table 2. MP-620 Mechanical and Compliance Specifications

Specification	Description
Maximum Channels (Outdoor)	Based on the country of operation specified by the system administrator
Data Rates	802.11a: 6, 9, 12, 18, 24, 36, 48, 54 Mbps per channel 802.11g: 6, 9, 11, 12, 18, 24, 36, 48, 54 Mbps per channel 802.11b: 1, 2, 5.5, 11 Mbps per channel
Maximum Clients	64 for the radio interface set to access point mode
Modulation Types	802.11a: BPSK, QPSK, 16-QAM, 64-QAM 802.11g: CCK, BPSK, QPSK, OFDM 802.11b: CCK, BPSK, QPSK
Network Configuration	Access Point Mode: Infrastructure
Operating Frequency	802.11a: 5.15 GHz to 5.825 GHz based on country regulations 802.11b/g: 2.4 GHz to 2.4835 GHz based on country regulations
Power Injector	Input: 100-240 VAC, 47-63 Hz, 1.5 A Output: 48 VDC, 1.2 A
Physical Size	19.8 x 19.8 x 6.33 cm (7.8 x 7.8 x 2.49 in)
Weight	4.8 kg (10.58 lbs)
Temperature	Operating: -33 to 55 °C (-27.4 to 131 °F) Storage: -40 to 80 °C (-40 to 176 °F)



Table 2. MP-620 Mechanical and Compliance Specifications

Specification	Description
Humidity	5% to 95% (non-condensing)
EMC Compliance (Class B)	FCC Class B (US) RTTED 1999/5/EC DGT (Taiwan)
Radio Signal Certification	FCC Part 15 15.407(b) (5 GHz) FCC Part 15.247 (2.4 GHz) IC RSS-210 EN 300.328, EN 302.893 EN 300 826, EN 301.489-1, EN 301.489-17 ETSI 300.328; ETS 300 826 (802.11b)
Safety	UL/cUL60950-1, IEC60950-1 (CB), IP68 (NEMA-250 6P)
Standards	IEEE 802.3 10BASE-T, IEEE 802.3u 100BASE-TX, IEEE 802.11a, b, g

Federal Communication Commission Interference Statement

This equipment has been tested and found to comply with the limits for a Class B digital device, pursuant to Part 15 of the FCC Rules. These limits are designed to provide reasonable protection against harmful interference in a residential installation. This equipment generates, uses and can radiate radio frequency energy and, if not installed and used in accordance with the instructions, may cause harmful interference to radio communications. However, there is no guarantee that interference will not occur in a particular installation. If this equipment does cause harmful interference to radio or television reception, which can be determined by turning the equipment off and on, the user is encouraged to try to correct the interference by one of the following measures:

- Reorient or relocate the receiving antenna.
- Increase the separation between the equipment and receiver.



- Connect the equipment into an outlet on a circuit different from that to which the receiver is connected.
- Consult the dealer or an experienced radio/TV technician for help.

This device complies with Part 15 of the FCC Rules. Operation is subject to the following two conditions: (1) This device may not cause harmful interference, and (2) this device must accept any interference received, including interference that may cause undesired operation.

FCC Caution: Any changes or modifications not expressly approved by the party responsible for compliance could void the user's authority to operate this equipment.

For operation within 5.15 ~ 5.25GHz frequency range, it is restricted to indoor environment.

IMPORTANT NOTE:

FCC Radiation Exposure Statement:

This equipment complies with FCC radiation exposure limits set forth for an uncontrolled environment. This equipment should be installed and operated with minimum distance 20cm between the radiator & your body.

This transmitter must not be co-located or operating in conjunction with any other antenna or transmitter.

IEEE 802.11b or 802.11g operation of this product in the U.S.A. is firmware-limited to channels 1 through 11.



MAC Addresses

Each MP-620 is assigned a unique block of 64 MAC addresses. Each radio has 32 MAC addresses and can therefore support up to 32 SSIDs, with one MAC address assigned to each SSID as its BSSID.

An MP's MAC address block is listed on a label on the back of the MP. If the MP is already deployed and running on the network, you can display the MAC address assignments by using the **show {ap | dap} status** command.

All MAC addresses on an MP are assigned based on the MP's base MAC address, as described in Table 3.

Table 3. MAC Address Allocations on MP-620

MP base MAC Address	<ul style="list-style-type: none"> The MP has a base MAC address. All the other addresses are assigned based on this address.
Ethernet Port MAC Addresses	<ul style="list-style-type: none"> The Ethernet port equals the MP base MAC address.
802.11a Radio and SSID MAC Addresses	<ul style="list-style-type: none"> The 802.11a radio equals the MP base MAC address + 1. The BSSIDs for the SSIDs configured on the 802.11a radio end in odd numbers. The first BSSID is equal to the MP's base MAC address + 1. The next BSSID is equal to the MP's base MAC address + 3, and so on.
802.11b/g Radio and SSID MAC Addresses	<ul style="list-style-type: none"> The 802.11b/g radio equals the MP base MAC address. The BSSIDs for the SSIDs configured on the 802.11b/g radio end in even numbers. The first BSSID is equal to the MP's base MAC address. The next BSSID is equal to the MP's base MAC address + 2, and so on.



Antenna Specifications

8 dBi Omnidirectional (2.4 GHz)

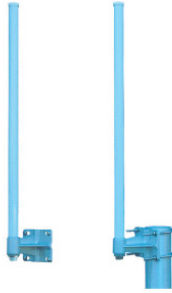

Table 4. 8 dBi Omnidirectional (2.4 GHz) Antenna Specifications

Specification	Description
Model Number	ANT-1360-OUT
Frequency Range	2.400 - 2.500 GHz
Gain	8 dBi
VSWR	2.0 : 1 max
Polarization	Linear, vertical
HPBW	Horizontal: 360°
Downtilt	0°
Power Handling	50 W (cw)
Impedance	50 Ohms
Connector	N type, male
Radome	Material: Fiber glass Color: Gray-white



Table 4. 8 dBi Omnidirectional (2.4 GHz) Antenna Specifications

Specification	Description
Environmental	Survival Wind Speed: 216 km/hr Temperature: -40 °C to 80 °C Humidity: 95% @ 25 °C
Mechanical	Dimensions: 58 x 2.1 cm (diameter) (22.8 x 0.82 in) Weight: 200 g (0.44 lbs)



8 dBi Omnidirectional (5 GHz)



Table 5. 8 dBi Omnidirectional (5 GHz) Antenna Specifications

Specification	Description
Model Number	ANT-5360-OUT
Frequency Range	5.725 - 5.875 GHz
Gain	8 dBi
VSWR	2.0 : 1 max
Polarization	Linear, vertical
HPBW	Horizontal: 360°
Downtilt	0°
Power Handling	5 W (cw)
Impedance	50 Ohms
Connector	N type, female
Radome	Material: Fiber glass Color: Gray-white
Environmental	Survival Wind Speed: 216 km/hr Temperature: -40 °C to 80 °C Humidity: 95% @ 25 °C
Mechanical	Dimensions: 32.5 x 2.2 cm diameter (12.8 x 8.6 in) Weight: 1100 g (2.4 lbs)

13.5 dBi 120-Degree Sector



Table 6. 13.5 dBi 120-Degree Sector Antenna Specifications

Specification	Description
Model Number	ANT-5120-OUT
Frequency Range	5.150 - 5.875 GHz
Gain	13.5 dBi
VSWR	2.0 : 1 max
Polarization	Linear, vertical
HPBW	Horizontal: 120° Vertical: 6°
Downtilt	0°
Power Handling	5 W (cw)
Impedance	50 Ohms
Connector	N type, female
Radome	Material: ABS Color: Gray, white
Environmental	Survival Wind Speed: 216 km/hr Temperature: -40 °C to 80 °C Humidity: 95% @ 25 °C
Mechanical	Dimensions: 62 x 8.8 x 7 cm (24.4 x 3.46 x 2.76 in) Weight: 590 g (1.3 lbs)

10 dBi 120-Degree Sector



Table 7. 10 dBi 120-Degree Sector Antenna Specifications

Specification	Description
Model Number	ANT-1120-OUT
Frequency Range	2.4 - 2.5 GHz
Gain	10 dBi
VSWR	2.0 : 1 max
Polarization	Linear, vertical
HPBW	Horizontal: 120° Vertical: 15°
Downtilt	0°
Power Handling	10 W (cw)
Impedance	50 Ohms
Connector	N type, female
Radome	Material: ABS Color: Gray, white

Table 7. 10 dBi 120-Degree Sector Antenna Specifications

Specification	Description
Environmental	Survival Wind Speed: 216 km/hr Temperature: -40 °C to 80 °C Humidity: 95% @ 25 °C
Mechanical	Dimensions: 75 x 8.8 x 7 cm (29.5 x 3.46 x 2.76 in) Weight: 700 g (1.5 lbs)



18 dBi 18-Degree Panel



Table 8. 18 dBi 18-Degree Panel Antenna Specifications

Specification	Description
Model Number	
Frequency Range	4.9 - 5.875 GHz
Gain	18 dBi
VSWR	2.0 : 1 max
Polarization	Linear, vertical
HPBW	Horizontal: 18° Vertical: 18°
Downtilt	0°
Power Handling	5 W (cw)
Impedance	50 Ohms
Connector	N type, female
Radome	Material: ABS Color: Gray, white



Table 8. 18 dBi 18-Degree Panel Antenna Specifications (continued)

Specification	Description
Environmental	Survival Wind Speed: 216 km/hr Temperature: -40 °C to 80 °C Humidity: 95% @ 25 °C
Mechanical	Dimensions: 21.5 x 20 x 5 cm (8.46 x 7.87 x 1.97 in) Weight: 825 g (1.82 lbs)

Signal Loss from Lightning Protector and Coaxial Cable

Frequency	Loss from Lightning Protector	Loss from 3m cable	Loss from 1.8m cable	Loss from 0.3m cable
2.4 GHz	0.08 dBi	0.75 dBi	0.59 dBi	0.24 dBi
5.5 GHz	0.25 dBi	1.17 dBi	0.89 dBi	0.37 dBi





Cables and Pinouts

This appendix describes the wiring and pin assignments for the cables and connectors that can be used with the MP-620.

Twisted-Pair Cable Assignments

For 10/100BASE-TX connections, a twisted-pair cable must have two pairs of wires. Each wire pair is identified by two different colors. For example, one wire might be green and the other, green with white stripes. Also, an RJ-45 connector must be attached to both ends of the cable.



Caution! Each wire pair must be attached to the RJ-45 connectors in a specific orientation.



Caution! DO NOT plug a phone jack connector into a power injector RJ-45 port. Use only twisted-pair cables with RJ-45 connectors that conform with FCC standards.

The following figure illustrates how the pins on the RJ-45 connector are numbered. Be sure to hold the connectors in the same orientation when attaching the wires to the pins.

Figure 13. Pin Numbering on RJ-45 Connector

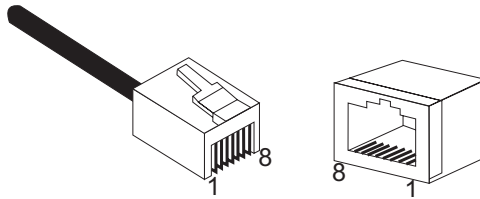

10/100BASE-TX Pin Assignments

Use unshielded twisted-pair (UTP) or shielded twisted-pair (STP) cable for RJ-45 connections: 100-ohm Category 3 or better cable for 10 Mbps connections, or 100-ohm Category 5 or better cable for 100 Mbps connections. Also be sure that the length of any twisted-pair connection does not exceed 100 meters (328 feet).

The RJ-45 Input port on the power injector is wired with MDI pinouts. This means that you must use crossover cables for connections to PCs or servers, and straight-through cable for connections to switches or hubs. However, when connecting to devices that support automatic MDI/MDI-X pinout configuration, you can use either straight-through or crossover cable.

Table 9. 10/100BASE-TX MDI and MDI-X Port Pinouts

Pin	MDI-X Signal Name	MDI Signal Name
1	Receive Data plus (RD+)	Transmit Data plus (TD+)
2	Receive Data minus (RD-)	Transmit Data minus (TD-)
3	Transmit Data plus (TD+)	Receive Data plus (RD+)
6	Transmit Data minus (TD-)	Receive Data minus (RD-)
4,5,7,8	Not used	Not used

Note: The “+” and “-” signs represent the polarity of the wires that make up each wire pair.

Straight-Through Wiring

Because the 10/100 Mbps Input port on the power injector uses an MDI pin configuration, you must use “straight-through” cable for network connections to hubs or switches that only have MDI-X ports. However, if the device to which you are connecting supports automatic MDI/MDI-X operation, you can use either “straight-through” or “crossover” cable.

Figure 14. Straight-Through Cable Wiring

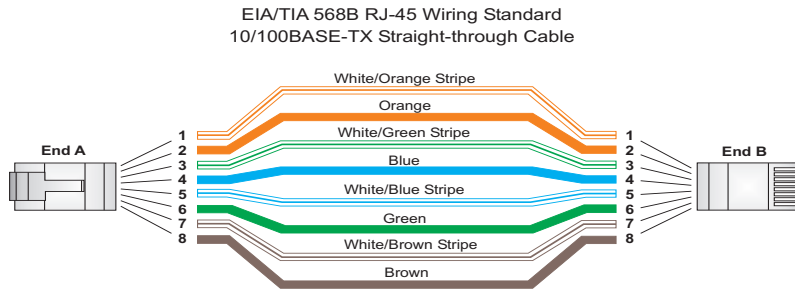

Crossover Wiring

Because the 10/100 Mbps port on the power injector uses an MDI pin configuration, you must use “crossover” cable for network connections to PCs, servers or other end nodes that only have MDI ports. However, if the device to which you are connecting supports automatic MDI/MDI-X operation, you can use either “straight-through” or “crossover” cable.

Figure 15. Crossover Cable Wiring

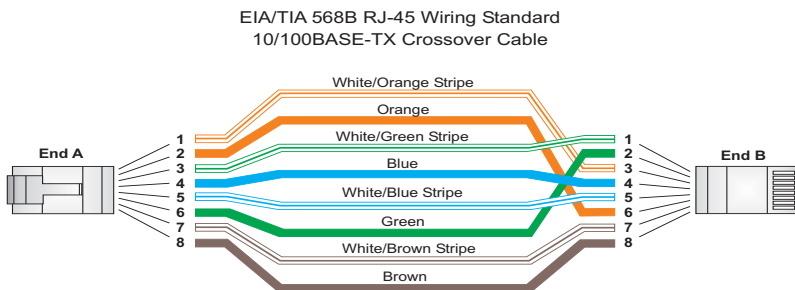

8-Pin DIN Connector Pinout

The Ethernet cable from the power injector connects to an 8-pin DIN connector on the MP-620. This connector is described in the following figure and table.

Figure 16. 8-Pin Ethernet DIN Connector

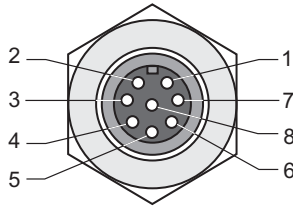

Table 10. 8-Pin DIN Ethernet Port Pinout

Pin	Signal Name
1	Transmit Data plus (TD+)
2	Transmit Data minus (TD-)
3	Receive Data plus (RD+)
4	+48 VDC power
5	+48 VDC power
6	Receive Data minus (RD-)
7	Return power
8	Return power

Note: The “+” and “-” signs represent the polarity of the wires that make up each wire pair.

8-Pin DIN to RJ-45 Cable Wiring

To construct an extended Ethernet cable to connect from the power injector's RJ-45 Output port to the MP-620's 8-pin DIN connector, follow the wiring diagram below. Use Category 5 or better UTP or STP cable, maximum length 100 m (328 ft), and be sure to connect all four wire pairs.



Note. To construct a reliable Ethernet cable, always use the proper tools or ask a professional cable supplier to construct the cable.

Figure 17. 8-Pin DIN to RJ-45 Cable Wiring

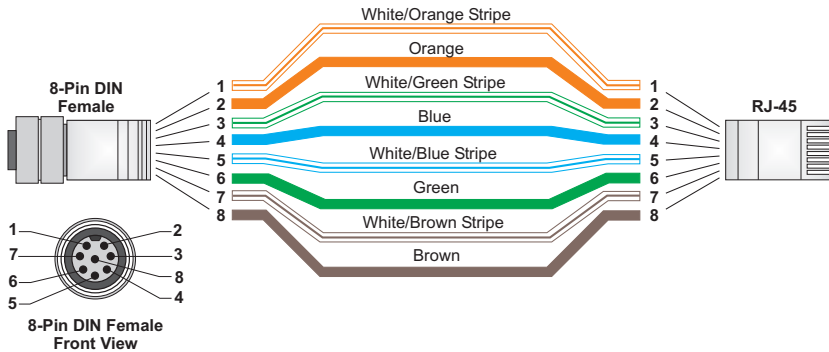

8-Pin DIN Connector Pinout
Appendix B



Index

A

access point. See MP (Mobility Point)
activating an MP 25
advisory notices, explanations of 4

C

cable
 assignments 43
 crossover 45
 straight-through 45
channels, maximum 30
clients, maximum 30
connections
 LEDs 27
 MX (Mobility Exchange) 25
conventions, text and syntax 5
crossover cable 45
CSMA/CA 8
customer service iii

D

data rate, options 30
documentation conventions 5
documentation, product 2

E

Ethernet
 connections to an MX switch, instructions
 25
 LEDs 27
 port 10

H

hardware
 bottom view 9
 features 9
 top view 9

I

IEEE 802.11a 8
installation
 MP 15, 19
 requirements 15
 warnings, radio 18
 warnings, service 7
IP addresses 33

L

LEDs
 MP (on MX) 27
links
 LEDs 27
 MP 27

M

MAC addresses 33
manuals, product 2
MDI, RJ-45 pin configuration 11
Mobility Exchange. See MX
Mobility Point. See MP
MP (Mobility Point)
 description of 7
 installation 15, 19
 specifications 29



MX (Mobility Exchange)
connections 25
MP LEDs 27
recommendation 16

N

network plan, RingMaster 15

O

OFDM 8
operating frequency 30

P

package checklist 8
PoE 24
PoE (Power over Ethernet)
use with Trapeze devices only 16
Power over Ethernet See PoE
power supply, specifications 30
product documentation 2

R

radios
default state 7
specifications 29
warnings 18
requirements 15
reset button 11
RingMaster
work order 15
RSSI BNC 12

S

safety notices, explanations of 4
specifications 29
straight-through cable 45
switch. See MX (Mobility Exchange)
syntax conventions 5

T

TAC (Technical Assistance Center) iii
Technical Assistance Center iii
technical specifications 29
technical support iii
Trapeze customer service iii
Trapeze Networks Mobility System 1

W

warnings
installation 7
radio 18
weather conditions 16
work order, RingMaster 15

