

# VICTROLA

## Suitcase Turntable with Bluetooth Function

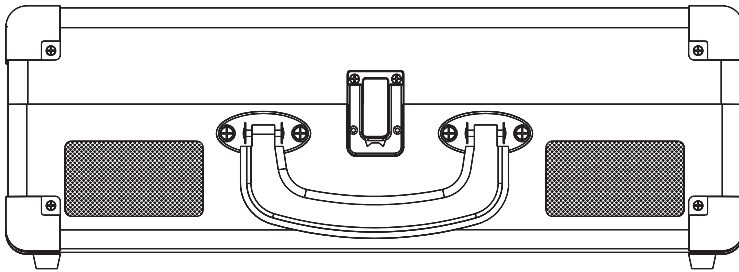

MODEL:VSC-550BT

PLEASE READ CAREFULLY BEFORE OPERATING THIS EQUIPMENT  
KEEP IT IN A SAFE PLACE FOR FUTURE REFERENCE

# IMPORTANT SAFETY INSTRUCTIONS



CAUTION: TO REDUCE THE ELECTRIC SHOCK, DO NOT REMOVE THE COVER (OR BACK). NO USER SERVICEABLE PART INSIDE, REFER SERVICING TO QUALIFIED SERVICE PERSONNEL.



**DANGEROUS VOLTAGE:** The lightning flash with arrowhead symbol within an equilateral triangle is intended to alert the user to the presence of uninsulated “dangerous voltage” within the product’s enclosure that may be of sufficient magnitude to constitute a risk of electric shock to persons.



**ATTENTION:** The exclamation point within an equilateral triangle is intended to alert the user to the presence of important operating and maintenance (servicing) instructions in the literature accompanying the appliance.

**WARNING: TO PREVENT FIRE OR SHOCK HAZARD, DO NOT EXPOSE THIS UNIT TO RAIN OR MOISTURE.**

**WARNING: USE UNDER SUPERVISION OF AN ADULT DUE TO LONG CORD** This unit has a long cord that can be easily tripped on or pulled on, causing injury. Please make sure it is arranged so that it will not drape over a tabletop, etc. Where it can be pulled on by children or tripped over accidentally.

## FCC NOTICE:

This equipment has been tested and found to comply with the limits for a Class B digital device, pursuant to Part 15 of the FCC Rules. These limits are designed to provide reasonable protection against harmful interference in a residential installation. This equipment generates, uses and can radiate radio frequency energy and, if not installed and used in accordance with the instructions, may cause harmful interference to radio communications. However, there is no guarantee that interference will not occur in a particular installation. If this equipment does cause harmful interference to radio or television reception, which can be determined by turning the equipment off and on, the user is encouraged to try to correct the interference by one or more of the following measures:

- Reorient or relocate the receiving antenna.
- Increase the separation between the equipment and receiver.
- Connect the equipment into an outlet on a circuit different from that to which the receiver is connected.
- Consult the dealer or an experienced radio/TV technician for help.

#### **FCC STATEMENT:**

This device complies with part 15 of the FCC Rules. Operation is subject to the following two conditions:

- (1) This device may not cause harmful interference, and
- (2) This device must accept any interference received, including interference that may cause undesired operation. The antenna(s) used for this transmitter must be installed to provide a separation distance of at least 20 cm from all persons and must not be co-located or operating in conjunction with any other antenna or transmitter.

#### **FCC WARNING:**

To assure continued operation, follow the attached installation instructions and use only shield cables when connecting to other devices. Changes or modifications not expressly approved by the party responsible for compliance could void the user's authority to operate the equipment.

## **IMPORTANT SAFETY INSTRUCTIONS**

Before using the unit, be sure to read all operating instruction carefully, please note that these are general precautions and may not pertain to your unit. For example, this unit may not have the capability to be connected to an outdoor antenna.

- (1) **Read these instructions**  
All the safety and operating instructions should be read before the appliance is operated.
- (2) **Keep these instructions**  
The safety and operating instructions should be kept for future reference.
- (3) **Heed all warnings**  
All warnings on the appliance and in the operating instructions should be adhered to.
- (4) **Follow all instructions**  
All operation and use instructions should be followed.
- (5) **Do not use this apparatus near water**  
The appliance should not be used near water; for example, near a bath tub, washbowl, kitchen sink, laundry tub, in a wet basement, or near a swimming pool.

**(6) Clean only with dry cloth**

The appliance should be cleaned only as recommended by the manufacturer.

**(7) Do not block any ventilation openings. Install in accordance with the manufacturer's instructions.**

Slots and openings in the cabinet and in the back or bottom are provided for ventilation, to ensure reliable operation of the product and to protect it from overheating. These openings must not be blocked or covered. The openings should never be blocked by placing the product on a bed, sofa, rug, or similar surface. This product should never be placed near or over a radiator or heat source. This product should not be placed in a built-in installation, such as a bookcase or rack unless proper ventilation is provided or the manufacturer's instructions have been adhered to.

**(8) Do not install near any heat sources such as radiators, heat registers, stoves, or other apparatus (including amplifiers) that produce heat.**

**(9) Do not defeat the safety purpose of the polarized or grounding-type plug. A polarized plug has two blades with one wider than the other. A grounding type plug has two blades and a third grounding prong. The wide or the third prong is provided for your safety. If the provided plug does not fit into your outlet, consult an electrician for replacement of the obsolete outlet.**

**(10) Protect the power cord from being walked on or pinched particularly at plugs, convenience receptacles, and the point where they exit from the apparatus.**

**(11) Only use attachments / accessories specified by the manufacturer.**

**(12) Use only with a cart, stand, tripod, bracket, or table specified by the manufacturer, or sold with the apparatus. When a cart is used, use caution when moving the cart/apparatus combination to avoid injury from tip-over.**



An appliance and cart combination should be moved with care. Quick stop, excessive force and uneven surfaces may cause the appliance and cart combination to overturn.

**(13) Unplug this apparatus during lightning storms or when unused for long periods of time.**

To protect your product from a lightning storm, or when it is left unattended and unused for long periods of time, unplug it from the wall outlet and disconnect the antenna or cable system. This will prevent damage to the product due to lightning and power-line surges.

**(14) Refer all servicing to qualified service personnel. Servicing is required when the apparatus has been damaged in any way, such as power-supply cord or plug is damaged, liquid has been spilled or objects have fallen into the apparatus, the apparatus has been exposed to rain or moisture, does not operate normally, or has been dropped.**

**(15) Power source**

This product should be operated only from the type of power source indicated on the marking label. If you are not sure of the type of power supply to your home, consult your appliance dealer or local power company. For products intended to operate from battery power, or other source, refer to the operation instructions.

**(16) Power lines**

An outside antenna system should not be located in the vicinity of overhead power lines or other electric light or power circuits, or where it can fall into such power lines or circuits. When installing an outside antenna system, extreme care should be taken to keep from touching such power lines or circuits as contact with them might be fatal.

**(17) Overloading**

Do not overload wall outlets and extension cords as this can result in a risk of fire or electric shock.

**(18) Object and liquid entry**

Never push objects of any kind into the product through openings as they may touch dangerous voltage points or short out parts that could result in fire or electric shock. Never spill or spray any type of liquid on the product.

**(19) Outdoor antenna grounding**

If an outside antenna is connected to the product, be sure the antenna system is grounded so as to provide some protection against voltage surges and built up static charges. Section 810 of the National Electric Code ANSI/ NFPA 70 provides information with respect to proper grounding of the mast and supporting structure, grounding of the lead-in wire to an antenna discharge product, size of grounding conductors, location of antenna- discharge product, connection to grounding electrodes and requirements for the grounding electrodes.

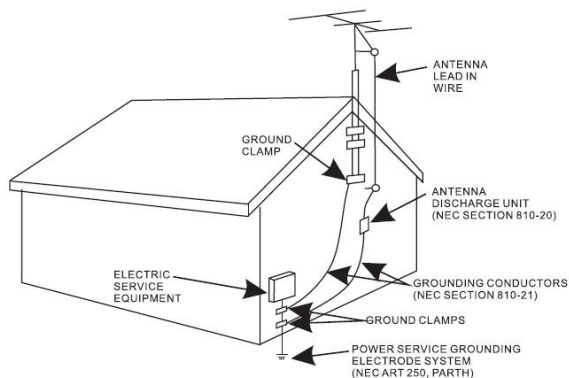

**(20) Service**

Do not attempt to service this product yourself as opening or removing covers may expose you to dangerous voltage or other hazards. Refer all servicing to qualified service personnel.

**(21) Replacement parts**

When replacement parts are required, be sure the service technician uses replacement parts specified by the manufacturer or those that have the same characteristics as the original parts. Unauthorized substitutions may result in fire or electric shock or other hazards.

**(22) Safety check**

Upon completion of any service or repairs to this product, ask the service technician to perform safety checks to determine that the product is in proper operating condition.

**(23) Wall or ceiling mounting**

The product should be mounted to a wall or ceiling only as recommended by the manufacturer.

**(24) Damage requiring service**

Unplug this product from the wall outlet and refer service to qualified service personnel under the following conditions.

- a) When the power- supply cord or plug is damaged.
- b) If liquid has been spilled or objects have fallen into the product.
- c) If the product has been exposed to rain or water.
- d) If the product does not operate normally by following the operating instructions. Adjust only those controls that are covered by the operating instructions, as an adjustment of other controls may result in damage and will require extensive work by a qualified technician to restore the product to its normal operation.
- e) If the product has been dropped or the cabinet has been damaged.
- f) When the product exhibits a distinct change in performance- this indicates a need for service.

**(25) Note to CATV system installer**

This reminder is provided to call the CATV system installer' s attention to Article 820- 40 of the NEC that provides guidelines for proper grounding and, in particular, specifies that the cable ground shall be connected to the grounding system of the building, as close to the point of cable entry as practical.

**NOTE: Refer all servicing to qualified service personnel. Servicing is required when the unit has been damaged in any way such as the following: the power-supply cord or plug has been damaged, liquid has been spilled into unit, the unit has been exposed to rain or moisture, the unit has been dropped or the unit does not operate normally.**

## BEFORE USING THE UNIT

- As the unit may become warm during operation, always leave sufficient space around the unit for ventilation.
- The voltage supplied to the unit should match the voltage as printed on the rear panel. If you are in any doubt regarding this matter, consult an electrician.
- Choose the installation location of your unit carefully. Avoid placing it in direct sunlight or close to a source of heat. Also avoid locations subject to vibrations and excessive dust, heat, cold or moisture.
- Do not place the unit on an amplifier/receiver.
- Do not open the cabinet as this might result in damage to the circuitry or electrical shock. If a foreign object should get into the unit, contact your dealer or service company.
- When removing the power plug from the wall outlet, always pull directly on the plug, never yank the cord.
- To keep the laser pickup clean, do not touch it, and always close the disc tray.
- Do not attempt to clean the unit with chemical solvents as this might damage the finish. Use a clean, dry cloth.
- Keep this manual in a safe place for future reference.

### **DO NOT MOVE THE UNIT DURING PLAYBACK**

During playback, the disc rotates at high speed. Do NOT lift or move the unit during playback. Doing so may damage the disc or the unit.

### **WHEN MOVING THIS UNIT**

When changing the unit's location or packing the unit for moving, be sure to remove the record or disc. Moving this unit with the record or disc loaded may result in damage to this unit. If the unit is to be packed and moved a great distance, it is also advisable to tighten the turntable transport locking screw.

## HANDLING RECORDS

- Do not touch the record's grooves. Only handle records by the edges or the label. Make sure your hands are clean. Skin oils from even clean hands can leave a residue on the record surface that will gradually deteriorate the quality of your record.

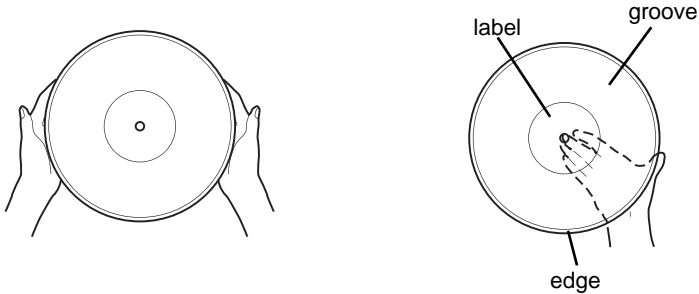

- Keep your records away from dust. Keep them in a cool, dry place.
- To avoid dust and scratches, keep records in their sleeves and jackets when not in use.
- Store records upright on their edges. Records stored horizontally will eventually bend and warp.
- Do not expose records to direct sunlight or high humidity and temperature. Long exposure to high temperatures will warp the record.
- Do not store your records in the trunk of your car. The temperature in a closed trunk can ruin your collection.
- Store records in an area with a stable temperature and low humidity.
- Should the record become dirty, gently wipe the surface in a circular motion, using a soft anti-static cloth.





## HOW TO REPLACE THE STYLUS

The stylus should last about 50 hours under normal use. However, it is recommended that the stylus be replaced as soon as you notice a change in sound quality.

### Caution:

- Do not remove or bend the stylus.
- To avoid injury, do not touch the needle.
- Turn off the unit's power before you replace the stylus.
- Keep out of the reach of children.
- Handle with care, as the stylus is delicate. Use of a bent or broken stylus may damage the record and cause the turntable stylus to malfunction.
- Do not expose stylus to extreme heat.
- Contact a qualified repair company if you experience difficulty in changing the stylus.

### Removing an old stylus:

1. Set a screwdriver at the tip of the stylus and push down to the direction "A".
2. Pull the stylus out toward direction "B".

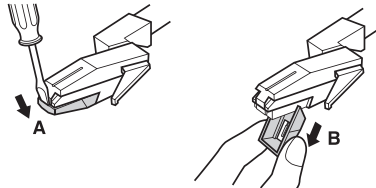

### Installing a new stylus

1. Hold the tip of the stylus and insert the other edge by pressing toward direction "C".
2. Push the stylus up toward direction "D" until it locks at the tip.

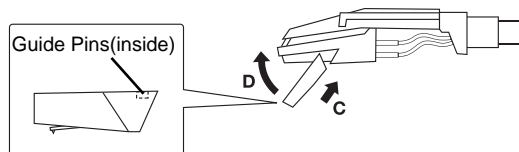

# Location of Controls

## Turndtable and Function Panel

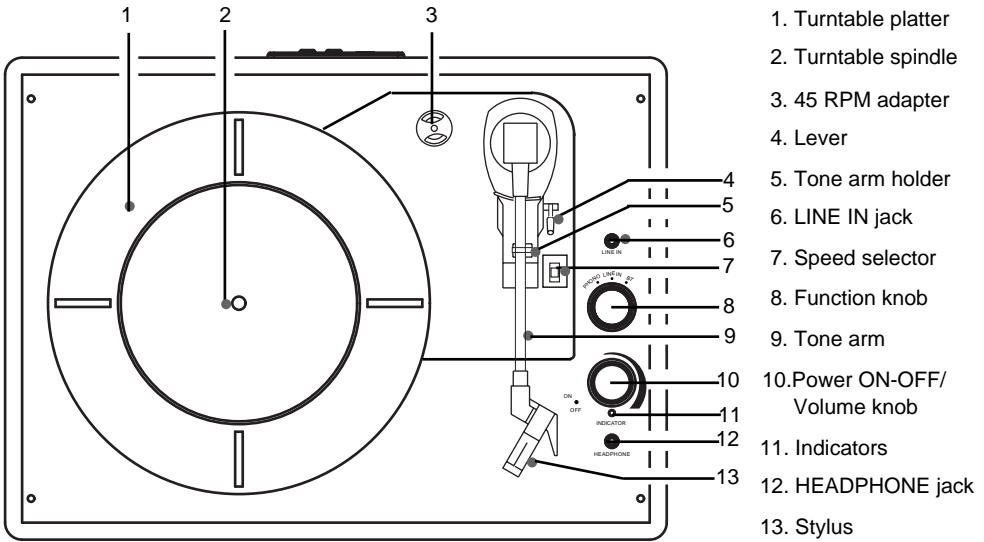

## Front View and Rear View

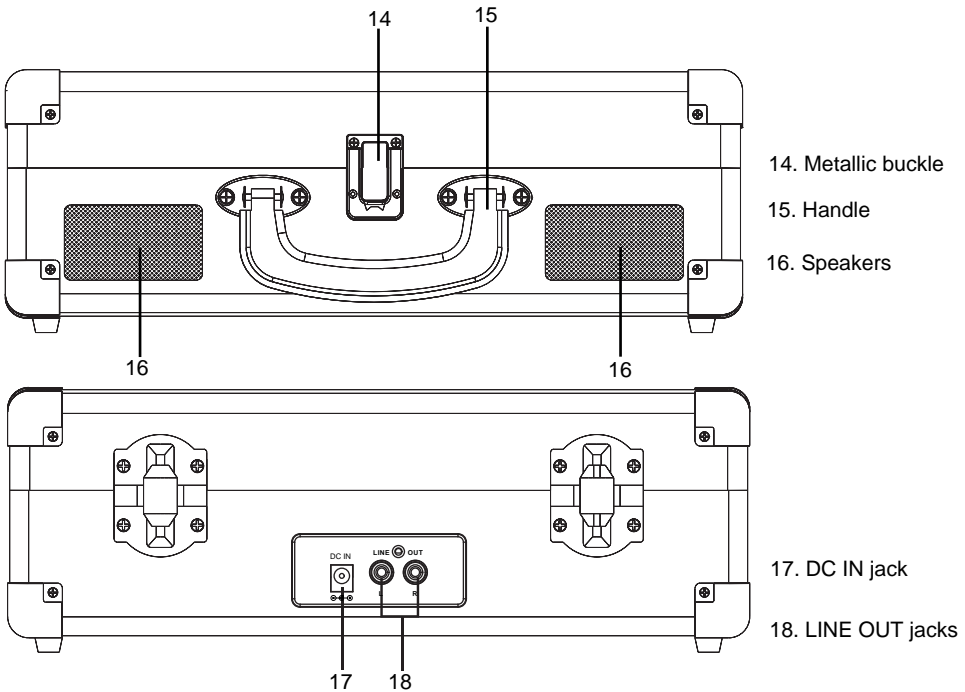

# Operation

## General Operation:

1. Open the top cover as the illustrated follows:

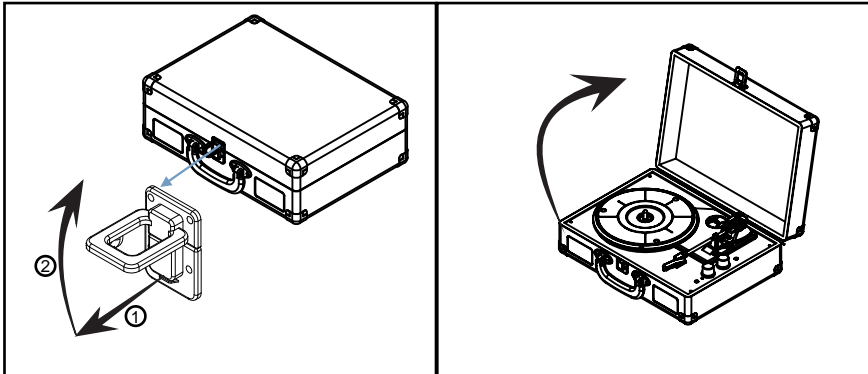

2. Connected the unit to AC power as instructed earlier.
3. Turn the Power ON/OFF--Volume knob clockwise to power on the unit and set the volume to the desired level. The indicator will illuminate.
4. Turn the Function selector to the desired position.
5. When finished listening, turn the Power ON/OFF--Volume knob counterclockwise until "Click" is heard to shut off the unit. The indicators will not light.
6. Close the cover then lock it.

## Listening through Bluetooth

### **(BT) Bluetooth:**

For first time use or re-pairing to a new BT Device, pairing it as below:

1. Power on the unit and turn the Function selector to BT position as the instructed earlier. The color of indicator will turn to Blue and blink.
2. Power on the external BT Device and enter to BT searching mode. Start pairing as the on screen instructions on the external BT Device. After paired, the Blue indicator will stop blinking, the tone sound of connected will hear.

(For details pairing procedures, please refer to the user's manual of your BT device.).

3. Plays the music in the paired BT Device as usual.

### Notes:

- When the external BT player searched the unit, our model number "Vintage Turntable" will appear on the display of external BT Device.

### **Normal operation after paired:**

1. Power on the unit and turn the Function selector to the BT position as the instructed earlier. The color of indicator will turn to Blue and blink.
2. Wait a few seconds until the unit auto paired to the external BT Device. (The Blue indicator will stop blinking, the tone sound of connected will be heard).
3. Plays the music in the paired BT Device as usual.
4. During playback, using the control buttons on the paired cell phone to skip the tracks; pause; play...etc.

## Listening a Record

1. In first time use, take off the protective cover from the stylus as the illustrated below:

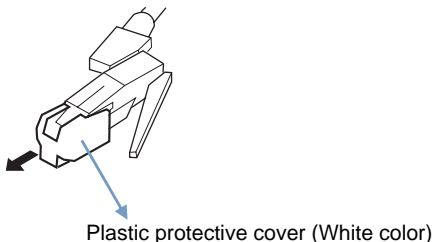

2. Place the Record on the center spindle.  
Note: If you are playing a 45 RPM Single (small size record), place the supplied 45 RPM adapter to the center spindle then place the record on it.
3. Slide the Speed selector to 33; 45 or 78 to match the play speed of the record.
4. Unlock the Tone Arm from the holder as the illustrated below:

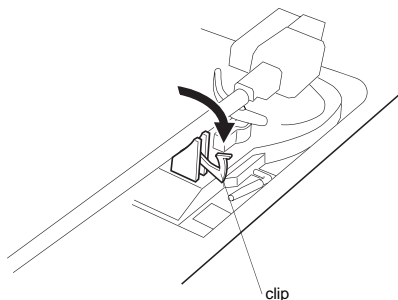

5. Power on the unit and turn the Function selector to the PHONO position as the instructed earlier. The color of indicator will turn to Red.
6. Raise the Lever to raising the Tone Arm then move it to the top of the desired location of the record. Release the Lever to put the Tone Arm onto the record. Plays will auto start.
7. When finished playback, the unit will auto stop turning (or you wants to stop immediately); raise the Lever to rising the Tone Arm then put it back to the Holder. Release the Lever then lock the Tone Arm on the Holder.

## Other Connections

### LINE IN:

Listen music from the external Audio Player as follows:

1. Connect one end of the Audio Connection Cable to the Phones Jack; Line Out Jack or AUX Out Jack on the external Audio Player.
2. Connect the other end to the LINE IN Jack on the top of unit as the illustrated below:

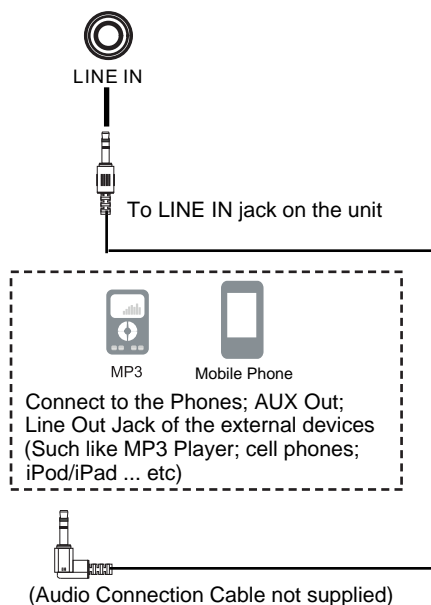

3. Power on the unit and turn the Function selector to the LINE IN position as the instructed earlier. The color of indicator will turn to Purple.
4. Plays the music on the connected external Audio Player as usual.

### LINE OUT:

To listening from external Audio Amplifier:

1. Connect one end of the RCA Audio Connection cable to the Line IN Jacks on the external Audio Amplifier.
2. Connect the other end of the cable to the LINE OUT jacks as the illustrated below:

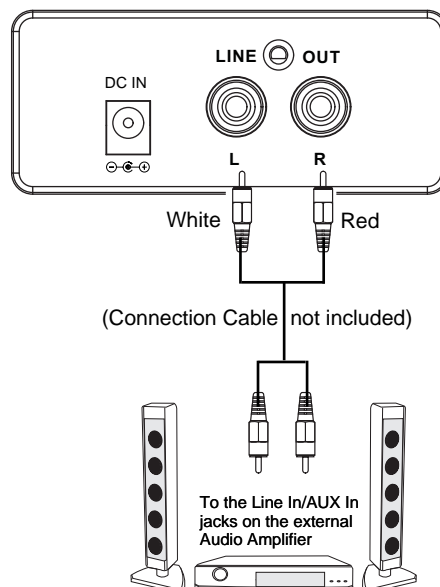

3. Power on the unit and plays music as usual.
4. Power on the external Audio Amplifier and set it to LINE IN mode to play the music.





### HEADPHONE:

For private listening, connect the 3.5mm plug from the Earphone/Headphone (not supplied) into the HEADPHONE jack on the top of unit. Sound from speakers will be auto cut.



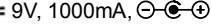

# Troubleshooting Guide

Symptom	Possible Cause	Solution
<b>Power</b>		
No power	AC/DC Adaptor had not connected to unit or wall outlet	Connected the AC/DC Adaptor to the unit and wall outlet
	Power ON-OFF/Volume knob is on power off position	Turn the Power ON-OFF/Volume knob clockwise to power on the unit and set the volume to the desired level
<b>Turntable</b>		
Noise or sound distorted	Speed selector wrong setting	Set the Speed selector to the correct position 33; 45 or 78 as the playing speed of record
	The stylus may abrasion after long time used	Replace it by the supplied extra stylus
<b>BT</b>		
BT not functioning	The BT Device had not paired to the unit	Paired the BT Device to the unit
Sound weak or distortion	The BT Device too far from the unit	Place the BT Device close to the unit

## General Specifications

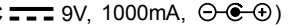
Power Source:	DC  9V, 1000mA,   
Audio Power:	1.8 W (RMS) x 2
Impedence of Speakers:	4 Ohm; 3W x 2
BT Version:	4.1
BT Effective Range:	32 feet in open area
Turntable:	
Speed:	33; 45; 78 rpm selectable
Type of Stylus:	CSC-015

## Accessories

- 1 x User's Manual
- 1 x AC/DC Adaptor (Input: AC 100-240V~; 50/60 Hz; 0.5A; Output: DC  9V, 1000mA,   )
- 2 x Stylus (one pre-mounted)
- 1 x 45 RPM Adaptor

**SPECIFICATIONS AND ACCESSORIES ARE SUBJECT TO CHANGE  
WITHOUT NOTICE**



