

# JVC

## HD MEMORY CARD CAMERA RECORDER

# GY-HM790U GY-HM790CHU GY-HM790E GY-HM790CHE

## INSTRUCTIONS

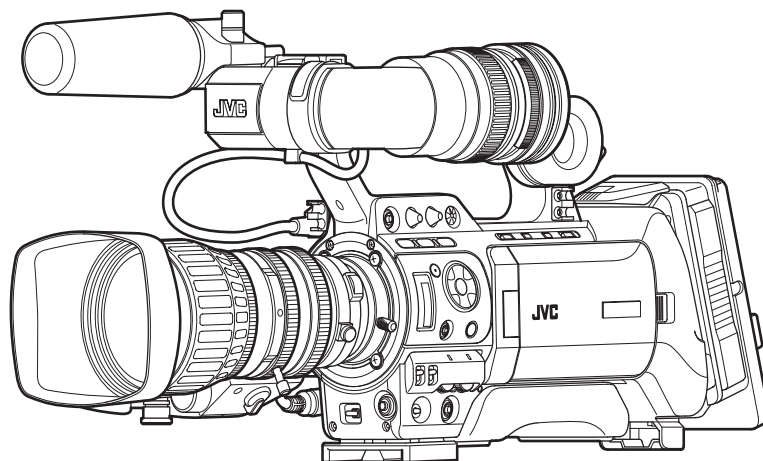

- \* The illustration shows the GY-HM790E with the supplied viewfinder, microphone and lens attached.
- \* GY-HM790CHU/GY-HM790CHE does not come with a lens.

### For Customer Use:

Enter below the Serial No. which is located on the body.  
Retain this information for future reference.

Model No. GY-HM790U/GY-HM790CHU

Serial No. \_\_\_\_\_

### Please read the following before getting started:

Thank you for purchasing this JVC product.  
Before operating this unit, please read the instructions  
carefully to ensure the best possible performance.

In this manual, each model number is described without the last letter  
(U/E) which means the shipping destination. (U: for USA and Canada,  
E: for Europe)

Only "U" models (GY-HM790CHU/GY-HM790U) have been evaluated by  
UL.

## Introduction

### FOR USA

These are general **IMPORTANT SAFEGUARDS** and certain items may not apply to all appliances.

### IMPORTANT SAFEGUARDS

1. Read all of these instructions.
2. Save these instructions for later use.
3. All warnings on the product and in the operating instructions should be adhered to.
4. Unplug this appliance system from the wall outlet before cleaning. Do not use liquid cleaners or aerosol cleaners. Use a damp cloth for cleaning.
5. Do not use attachments not recommended by the appliance manufacturer as they may cause hazards.
6. Do not use this appliance near water - for example, near a bathtub, washbowl, kitchen sink, or laundry tub, in a wet basement, or near a swimming pool, etc.
7. Do not place this appliance on an unstable cart, stand, or table. The appliance may fall, causing serious injury to a child or adult, and serious damage to the appliance. Use only with a cart or stand recommended by the manufacturer, or sold with the appliance. Wall or shelf mounting should follow the manufacturer's instructions, and should use a mounting kit approved by the manufacturer. An appliance and cart combination should be moved with care. Quick stops, excessive force, and uneven surfaces may cause the appliance and cart combination to overturn.
8. Slots and openings in the cabinet and the back or bottom are provided for ventilation, and to insure reliable operation of the appliance and to protect it from overheating, these openings must not be blocked or covered. The openings should never be blocked by placing the appliance on a bed, sofa, rug, or other similar surface. This appliance should never be placed near or over a radiator or heat register. This appliance should not be placed in a built-in installation such as a bookcase unless proper ventilation is provided.
9. This appliance should be operated only from the type of power source indicated on the marking label. If you are not sure of the type of power supplied to your home, consult your dealer or local power company. For appliance designed to operate from battery power, refer to the operating instructions.
10. For added protection for this product during a lightning storm, or when it is left unattended and unused for long periods of time, unplug it from the wall outlet and disconnect the antenna or cable system. This will prevent damage to the product due to lightning and power-line surges.
11. Do not allow anything to rest on the power cord. Do not locate this appliance where the cord will be abused by persons walking on it.
12. Follow all warnings and instructions marked on the appliance.
13. Do not overload wall outlets and extension cords as this can result in fire or electric shock.
14. Never push objects of any kind into this appliance through cabinet slots as they may touch dangerous voltage points or short out parts that could result in a fire or electric shock. Never spill liquid of any kind on the appliance.
15. Do not attempt to service this appliance yourself as opening or removing covers may expose you to dangerous voltage or other hazards. Refer all servicing to qualified service personnel.
16. Unplug this appliance from the wall outlet and refer servicing to qualified service personnel under the following conditions:
  - a. When the power cord or plug is damaged or frayed.
  - b. If liquid has been spilled into the appliance.
  - c. If the appliance has been exposed to rain or water.
  - d. If the appliance does not operate normally by following the operating instructions. Adjust only those controls that are covered by the operating instructions as improper adjustment of other controls may result in damage and will often require extensive work by a qualified technician to restore the appliance to normal operation.
  - e. If the appliance has been dropped or the cabinet has been damaged.
  - f. When the appliance exhibits a distinct change in performance - this indicates a need for service.
17. When replacement parts are required, be sure the service technician has used replacement parts specified by the manufacturer that have the same characteristics as the original part. Unauthorized substitutions may result in fire, electric shock, or other hazards.
18. Upon completion of any service or repairs to this appliance, ask the service technician to perform routine safety checks to determine that the appliance is in safe operating condition.

PORTABLE CART WARNING  
(symbol provided by RETAC)



S3125A

# Safety Precautions

## FOR USA AND CANADA



### CAUTION

RISK OF ELECTRIC SHOCK  
DO NOT OPEN



**CAUTION:** TO REDUCE THE RISK OF ELECTRIC SHOCK. DO NOT REMOVE COVER (OR BACK). NO USER-SERVICEABLE PARTS INSIDE. REFER SERVICING TO QUALIFIED SERVICE PERSONNEL.



The lightning flash with arrowhead symbol, within an equilateral triangle is intended to alert the user to the presence of uninsulated "dangerous voltage" within the product's enclosure that may be of sufficient magnitude to constitute a risk of electric shock to persons.



The exclamation point within an equilateral triangle is intended to alert the user to the presence of important operating and maintenance (servicing) instructions in the literature accompanying the appliance.

## INFORMATION:

This equipment has been tested and found to comply with the limits for a Class A digital device, pursuant to Part 15 of the FCC Rules. These limits are designed to provide reasonable protection against harmful interference when the equipment is operated in a commercial environment.

This equipment generates, uses, and can radiate radio frequency energy and, if not installed and used in accordance with the instruction manual, may cause harmful interference to radio communications.

Operation of this equipment in a residential area is likely to cause harmful interference in which case the user will be required to correct the interference at his own expense.

## CAUTION:

CHANGES OR MODIFICATIONS NOT APPROVED BY JVC COULD VOID USER'S AUTHORITY TO OPERATE THE EQUIPMENT.

THIS DEVICE COMPLIES WITH PART 15 OF THE FCC RULES. OPERATION IS SUBJECT TO THE FOLLOWING TWO CONDITIONS: (1) THIS DEVICE MAY NOT CAUSE HARMFUL INTERFERENCE, AND (2) THIS DEVICE MUST ACCEPT ANY INTERFERENCE RECEIVED, INCLUDING INTERFERENCE THAT MAY CAUSE UNDESIRE OPERATION.

## POUR CANADA



### ATTENTION

RISQUE D'ELECTROCUTION NE PAS OUVRIR



**ATTENTION:** POUR EVITER TOUT RISQUE D'ELECTROCUTION NE PAS OUVRIR LE BOITER. AUCUNE PIECE INTERIEURE N'EST A REGLER PAR L'UTILISATEUR. SE REFERER A UN AGENT QUALIFIE EN CAS DE PROBLEME.



Le symbole de l'éclair à l'intérieur d'un triangle équilatéral est destiné à alerter l'utilisateur sur la présence d'une "tension dangereuse" non isolée dans le boîtier du produit. Cette tension est suffisante pour provoquer l'électrocution de personnes.



Le point d'exclamation à l'intérieur d'un triangle équilatéral est destiné à alerter l'utilisateur sur la présence d'opérations d'entretien importantes au sujet desquelles des renseignements se trouvent dans le manuel d'instructions.

Ces symboles ne sont utilisés qu'aux Etats-Unis.

## INFORMATION (FOR CANADA) RENSEIGNEMENT (POUR CANADA)

This Class A digital apparatus complies with Canadian ICES-003.

Cet appareil numérique de la Class A est conforme à la norme NMB-003 du Canada.

**WARNING:**  
TO REDUCE THE RISK OF FIRE OR ELECTRIC SHOCK, DO NOT EXPOSE THIS APPLIANCE TO RAIN OR MOISTURE.

**CAUTION:**  
This unit should be used with 12V DC only. To prevent electric shocks and fire hazards, do NOT use any other power source.

**AVERTISSEMENT:**  
POUR EVITER LES RISQUES D'INCENDIE OU D'ELECTROCUTION, NE PAS EXPOSER L'APPAREIL A L'HUMIDITE OU A LA PLUIE.

**ATTENTION:**  
Ce magnétoscope ne doit être utilisé que sur du courant direct en 12V. Afin d'éviter tout risque d'incendie ou d'électrocution, ne pas utiliser d'autres sources d'alimentation électrique.

**NOTE:**  
The rating plate (serial number plate) is on the unit.

**REMARQUE:**  
La plaque signalétique (plaque du numéro de série) est située sur le cadre inférieur de l'unité.

**CAUTION:**  
To prevent electric shock, do not open the cabinet. No user serviceable parts inside. Refer servicing to qualified service personnel.

Due to design modifications, data given in this instruction book are subject to possible change without prior notice.

The apparatus shall not be exposed to dripping or splashing and that no objects filled with liquids, such as vases, shall be placed close to the apparatus.

# Safety Precautions (continued)

### FOR EUROPE

This equipment is in conformity with the provisions and protection requirements of the corresponding European Directives. This equipment is designed for professional video appliances and can be used in the following environments:

- Controlled EMC environment (for example, purpose-built broad-casting or recording studio), and rural outdoors environments.

In order to keep the best performance and furthermore for electromagnetic compatibility we recommend to use cables not exceeding the following lengths:

Port	Cable	Length
[DC INPUT]	Exclusive Cable	5 m
[Y/VIDEO], [PB], [PR]	Coaxial Cable	10 m
[AUDIO INPUT 1/2]	Shielded Cable	3 m
[AUDIO OUTPUT]	Shielded Cable	10 m
[PHONES]	Exclusive Cable	3 m
[IEEE1394]	Exclusive Cable	3 m
[HD/SD-SDI]	Coaxial Cable	10 m
[REMOTE]	Exclusive Cable	5 m
[LENS]	Unshielded Cable	0.1 m
[VF]	Special Cable	0.3 m
[USB]	Shielded Cable	2 m
[GENLOCK INPUT]	Shielded Cable	10 m
[TC IN]	Shielded Cable	10 m
[TC OUT]	Shielded Cable	10 m
[STUDIO]	Exclusive Cable	0.3 m

#### Caution:

Where there are strong electromagnetic waves or magnetism, for example near a radio or TV transmitter, transformer, motor, etc., the picture and the sound may be disturbed. In such case, please keep the apparatus away from the sources of the disturbance.

#### Dear Customer,

This apparatus is in conformance with the valid European directives and standards regarding electromagnetic compatibility and electrical safety.

European representative of Victor Company of Japan, Limited is:  
JVC Technical Services Europe GmbH  
Postfach 10 05 04  
61145 Friedberg  
Germany

#### Sehr geehrter Kunde, sehr geehrte Kundin,

dieses Gerät stimmt mit den gültigen europäischen Richtlinien und Normen bezüglich elektromagnetischer Verträglichkeit und elektrischer Sicherheit überein.

Die europäische Vertretung für die Victor Company of Japan, Limited ist:  
JVC Technical Services Europe GmbH  
Postfach 10 05 04  
61145 Friedberg  
Deutschland

### Information for Users on Disposal of Old Equipment [European Union]



#### Attention:

This symbol is only valid in the European Union.

This symbol indicates that the electrical and electronic equipment should not be disposed as general household waste at its end-of-life. Instead, the product should be handed over to the applicable collection point for the recycling of electrical and electronic equipment for proper treatment, recovery and recycling in accordance with your national legislation.

By disposing of this product correctly, you will help to conserve natural resources and will help prevent potential negative effects on the environment and human health which could otherwise be caused by inappropriate waste handling of this product. For more information about collection point and recycling of this product, please contact your local municipal office, your household waste disposal service or the shop where you purchased the product. Penalties may be applicable for incorrect disposal of this waste, in accordance with national legislation.

#### (Business users)

If you wish to dispose of this product, please visit our web page <http://www.jvc.eu> to obtain information about the take-back of the product.

#### [Other Countries outside the European Union]

If you wish to dispose of this product, please do so in accordance with applicable national legislation or other rules in your country for the treatment of old electrical and electronic equipment.



FOR USE IN CHINA ONLY

## 《电子信息产品污染控制管理办法》规定的表示内容

### 关于环保使用期限



● 此图标表示了中国《电子信息产品污染控制管理办法》规定的环保使用期限。只要用户在使用本产品时遵守注意事项中的各项规定，从制造日期开始到此图标标出的期限为止（环保使用期限）既不会污染环境也不会产生对人体有害的物质。

环保使用期限

### 关于产品中的有毒、有害物质

零件名称	有毒或有害物质、元素					
	铅 (Pb)	水银 (Hg)	镉 (Cd)	六价铬 (Cr6+)	多溴联苯 (PBB)	多溴二苯醚 (PBDE)
线路板组件	x	o	o	x	o	o
机箱	x	o	o	x	o	o
液晶显示屏	x	o	o	x	o	o
其他附件	x	o	o	x	o	o

o：此零件中的每个均匀材料所含有的有毒、有害物质的量在SJ/T 11363-2006标准规定的范围之内。  
x：此零件中至少有一种均匀材料含有有毒、有害物质的量超过了SJ/T 11363-2006标准的规定。

## Contents

### Introduction

Main Features	4
Precautions for Proper Use	5
Operation Mode	8
Names of Parts	10
Side Control Panel	12
Viewfinder	13
LCD Monitor	13
Side Terminal	14
SD Slot	15
Rear	15
Zoom Lens	16
Basic System Diagram	17
Displays on the LCD Monitor and Viewfinder	18
Status Screen	18
Enlarged Status Display on LCD Monitor	19
Auto White Display (Camera Mode Only, Excluding AUX Mode)	20
Menu Setting Screen	20
Alarm Display	20
Zebra Pattern Display	20

### Preparations

Attaching Accessories	21
Attaching the Zoom Lens	21
Attaching the Microphone (Supplied)	21
Attaching the Viewfinder (Supplied)	21
Power Supply	22
Using AC Power (DC IN Power)	22
Using a Battery Pack	22
Turning On/Off the Power	25
Setting the Clock (Initial Setting)	26
Adjusting the Monitor Speaker	27
Adjusting Back Focus	28
Adjusting the LCD Monitor and Viewfinder	28
Tally Lamps	30
SDHC Cards	31
SDHC Cards to Use	31
Formatting (Initializing) SDHC Cards	33
Restoring the SDHC Card	34
Clips Recorded to SDHC Cards	35
Recording Clips	35

### Shooting

Basic Shooting Procedures	36
Shooting	36
Focus Assist Function	37
Selecting System Definition, File Format and Video Format	38
Selecting the Aspect Ratio of SD Videos	39
Adjusting the Iris	39
Setting Gain	40
Setting the Electronic Shutter	40
Adjusting the White Balance	42
Adjusting the White Shading	44
Setting the ND Filter	45
Adjusting Audio Input Settings and Recording Level	46
Setting Audio Input	46
Adjusting Audio Recording Level	46
Audio Monitor During Recording	47
Time Code and User's Bit	48
Displaying Time Code and User's Bit	48
Time Code Operation Mode	48
Using the Internal Time Code Generator	49
Presetting the Time Code	49
Presetting the User's Bit	50
Setting Time Code Without Opening the Menu	51
Setting User's Bit Without Opening the Menu	52
Recording Time Code in Continuation of the Recorded Time Code on SDHC card	52
Synchronizing Time Code with External Time Code Generator	52
Setting Zebra Pattern	54
Setting Spot Meter	55
Viewing Recorded Videos Immediately (Clip Review)	56
Assigning Functions to User Buttons	57
Protecting Important Scenes (OK Mark Function)	58
Special Recording	58
Pre Rec	58
Clip Continuous Rec	59
Variable Frame Rec	60

### Playback

Playing Back Recorded Clips	61
Thumbnail Screen	61
Playing Back	65
Thumbnail Menu	65
Deleting Clips	66
Appending and Deleting OK Marks	68

## Menu Display and Detailed Settings

Basic Operations in Menu Screen .....	70
Display and Description of the Menu Screen .....	70
Text Input with Software Keyboard .....	71
Menu Screen Hierarchical Chart .....	72
Main Menu Screen .....	74
Record Set Menu .....	75
Record Format Menu .....	75
Rec Mode Menu .....	76
Clip Set Menu .....	76
Audio Set Menu .....	77
Camera Function Menu .....	78
Switch Set Item .....	79
FULL AUTO Item .....	81
Camera Process Menu .....	82
Detail/Adjust... Item .....	84
White Balance Item .....	85
Shading Mode/Adjust Item .....	86
Color Matrix/Adjust Item .....	86
TC/UB Menu .....	88
LCD/VF Menu .....	88
Shooting Assist Item .....	89
Marker Setting Item .....	90
Status Display Item .....	90
A/V Out Menu .....	92
Others Menu .....	93
Genlock Adjust Item .....	96
Media Menu .....	97
Setup File Manage Menu .....	97
Adding/Editing Frequently Used Menu Items (Favorites Menu) .....	98
Adding Menu Items to Favorites Menu .....	98
Editing Favorites Menu .....	99

## Status Screen

Status Screen in Camera Mode .....	102
Status Screen in SD Card Mode .....	108
Status Screen in IEEE1394 Input Mode .....	109
Enlarged Status Display on LCD Monitor .....	110

## Camera Features

Marker and Safety Zone Displays (Camera Mode Only, Excluding AUX Mode) .....	112
Smoothering the Skin Color (Skin Detail Function) .....	114
Color Bar Output .....	115
Color Matrix Adjustment .....	116
Reproduction of Dark Areas (Black Stretch/Compress Function) .....	118

Configuring Setup Files .....	119
Saving Setup Files .....	120
Loading a Setup File .....	121
Resetting Setup Files .....	121

## Connecting External Devices

Connecting an External Monitor .....	122
IEEE1394 Connection .....	123
Backup Recording .....	124
Input of Composite Video Signals from External Device (GY-HM790CHU/GY-HM790U only) .....	125
Input of External Synchronizing Signal (Genlock) .....	126
Displaying Return Video from External Device .....	128
Studio System Connection .....	129
Managing/Editing Clips on a PC .....	130
Remote Control Unit Connection .....	131
List of Remote Control Unit Functions .....	132

## Others

Error Displays and Actions .....	134
Tally Lamps .....	135
Alarm Tone .....	135
Troubleshooting .....	136
Specifications .....	137

### How to use this manual

#### ■ Symbols used

- Note** : Describes precautions concerning the operation of this product.
- Memo** : Describes reference information, such as functions and usage restrictions of this product.
-  : Indicates the reference page numbers and reference items.

#### ■ Content of this manual

- All rights reserved by JVC. Unauthorized duplication or reprinting of this manual, in whole or in part, is strictly prohibited.
- All other product names used in this manual are trademarks or registered trademarks of their respective companies. Marks such as **™**, **®**, **©** have been omitted in this manual.
- Illustrated designs, specifications and other contents of this manual are subject to change for improvement without prior notice.

## Introduction

### Main Features

This camera recorder enables recording of HD/SD format images to an SDHC card, and also playback of these images.

#### [GENLOCK INPUT], [TC IN], [TC OUT] Terminals and Return Video Function

Equipped with a function that enables use of multiple cameras as well as use as a studio camera.

#### SD (Standard Definition) Recording

Supports DV compression of SD images and recording in the QuickTime or AVI file format.

The use of a wide array of non-linear editing software is also supported, which helps to ease production of SD videos, such as DVDs.

#### Recording in QuickTime File Format

Recording can be made in QuickTime file format of Final Cut Pro, a video editing software from Apple Inc.

You can edit the recorded clips directly with Final Cut Pro.

#### Recording in MP4 File Format

This camera supports recording in the MP4 file format for Windows NLE systems, which can be utilized in a wide range of non-linear editing environments.

#### Recording on SDHC Memory Card (Class 6/10)

The absence of mechanisms with the use of SDHC (Class 6/10) as recording media brings about increased operation reliability. In addition, the improved compatibility with computers enables high-speed data transfer to NLE as well as reduction of operating costs.

#### 35 Mbps High Image Quality Mode

This camera recorder is equipped with a 35 Mbps high quality mode, in addition to the HDV mode bit rate (19/25 Mbps).

#### Dual Media Slots

Continuous recording is possible by loading two recording media, thereby allowing a long recording time.

#### Wide Variety of Recording Formats

This camera recorder supports various HD formats (1080i, 1080p, 720p) as well as SD (DV) formats (480i : U model, 576i : E model), enabling it to be used under various environments. It also supports 1440x1080 and 1920x1080 full resolution in the 1080 format.

#### Adoption of MPEG-2 Long GOP for Easy Editing

Shortens editing and output time by adopting MPEG-2 codec, which puts less stress on the editing computer.

#### High Resolution via Triplex Offset

2.5k x 1.4k pixels are generated with the Triplex Offset, and a high resolution of more than 900 horizontal lines and 1000 diagonal lines is achieved using the proprietary front processing.

#### Spot Meter Function

The brightest and darkest positions on the screen are automatically detected and displayed together with the dynamic range. As this is a pre-gamma value, it allows you to understand the lighting ratio and prevents overexposure or underexposure in shooting scenes where lighting is controlled.

#### High Resolution Viewfinder

With a high resolution of 852 x 480 in 0.425 inches, the viewfinder is now more robust and enables more accurate focusing.

#### High Resolution LCD Monitor

Equipped with a 4.3 inch 800x480 large LCD monitor, both shooting precision and viewing performance are improved.

#### Intuitive User Interface

The sophisticated user interface allows more intuitive operations. Thumbnail display is also available for you to easily select a recorded clip for playback.

#### Compact Shoulder Style

By inheriting the compact shoulder style from the GY-HD100 series which is widely accepted in the industry, more stable shooting can be done on this camera recorder while its weight remains similar to that of a handheld camera recorder.

#### Lens Interchangeability

Existing lenses can be used, thus saving on costs. You can also select the most appropriate lens according to your shooting requirements.

#### Professional Batteries

Batteries such as Anton Bauer and IDX batteries that are used in the broadcast industry can be used with this camera recorder.

#### Support for Wide Variety of Output

Supports industrial output such as HD-SDI output and IEEE1394 output.

---

## Application Software Provided

The [JVC ProHD Clip Manager] application software is provided for you to copy recorded clips to Windows or Macintosh computers and for checking the video images. (For MP4 file format)

**The CD-ROM provided with this camera recorder comes with [JVC ProHD Clip Manager] and other application software as well as their user guides.**

\* For details, refer to the user guides for each application software.

---

## Precautions for Proper Use

---

### Storage and Usage Locations

■ Allowable ambient temperature and humidity

Be sure to use this unit within the allowable temperature range of 0 °C to 40 °C and a relative humidity of 30 % to 80 %. Using this unit at a temperature or humidity outside the allowable ranges could result not only in malfunction but also serious impact on the CCD elements as small white spots may be generated. Please exercise care during use.

■ Strong electromagnetic waves or magnetism

Noise may appear in the picture or audio and/or the colors may be incorrect if this unit is used near a radio or television transmitting antenna, in places where strong magnetic fields are generated by transformers, motors, etc., or near devices emitting radio waves, such as transceivers or cellular phones.

■ Use of wireless microphone near this unit

When a wireless microphone or wireless microphone tuner is used near this unit during recording, the tuner could pick up noise.

■ Avoid using or placing this unit in the following places.

- Places subject to extreme heat or cold
- Places with excessive dirt or dust
- Places with high humidity or moisture
- Places subject to smoke or vapor such as near a cooking stove
- Places subject to strong vibrations or unstable surfaces
- In a parked car under direct sunlight or near a heater for long hours.

■ Do not place this unit at places that are subject to radiation or X-rays, or where corrosive gases occur.

■ Protect this unit from being splashed with water. (Especially when shooting in the rain)

■ Protect this unit from getting wet when shooting on a beach. In addition, salt and sand may adhere to the body. Be sure to clean the unit after use.

■ Protect this unit against penetration of dust when using it in a place subject to sandy dust.

---

### Transportation

Do not drop or hit this unit against a hard object when transporting.

---

### Power Saving

■ When this unit is not in use, be sure to set the [POWER] switch to "OFF" in order to reduce power consumption.

# Precautions for Proper Use (continued)

## Maintenance

- Turn off the power before performing any maintenance.
- Wipe the external cabinet of the unit with a soft cloth. Do not wipe the body with benzene or thinner. Doing so may cause the surface to melt or turn cloudy. When it is extremely dirty, soak the cloth in a solution of neutral detergent, wipe the body with it, and then use a clean cloth to remove the detergent.

## Batteries

- The following batteries can be used on this unit.  
GY-HM790CHU/GY-HM790U : Dionic90 (Anton Bauer)  
GY-HM790CHE/GY-HM790E : Endura-HL9 (IDX)  
\* Models with an E suffix are for the European market and the UL Listing mark is not applicable.
- Make use of the recommended batteries. Heavy batteries may fall off if not used correctly.

## Regular Inspection (Maintenance)

Under normal environment, dust will accumulate on the camera recorder when it is used over a long period. Dust may enter the camera recorder especially if it is used outdoors. This may affect the image and sound quality of the camera recorder. Check and replace the fan after every 9000 hours (suggested guideline).

You can check the usage time of the fan in the [Others] menu → [System Information] → [Fan Hour]. (Page 95)  
If the fan is used for more than 9000 hours without replacement, "FAN MAINTENANCE REQUIRED" will be displayed every time you turn on the power.

## SDHC Cards

Use an SDHC card (4 GB to 32 GB) with Class 6 or higher performance.  
Using cards other than those from Panasonic, TOSHIBA or SanDisk may result in recording failure or data loss.

## Others

- Do not insert objects other than the memory card into the card slot.
- Do not block the vent on the unit.  
Blocking of the vent causes internal heating and may lead to burns and fires.
- Do not turn off the [POWER] switch or remove the power cable during recording or playback.
- The camera recorder may not show stable pictures for a few seconds immediately after the power is turned on, but this is not a malfunction.
- When the video signal output terminals are not in use, put on the covers to prevent damage to the terminals.
- Do not drop this unit or subject it to strong impact or vibration as it is a precision equipment.
- Optical performance of lens  
Due to the optical performance of the lens, color divergence phenomena (magnification chromatic aberration) may occur at the periphery of the image. This is not a camera malfunction.

## LCD Monitor and Viewfinder

- The LCD monitor and viewfinder screens are manufactured using high-precision technology. Black spots may appear on the LCD monitor and viewfinder screens, or red, blue, and/or white spots may not disappear. However, this is not a malfunction and these spots are not recorded on the SDHC card.
- If you use this unit continuously for a long period of time, the characters displayed in the viewfinder may temporarily remain on the screen. This is not recorded on the SDHC card. They will not appear after you turn the power off and then on again.
- If you use this unit in a cold place, the images may appear to lag on the screen, but this is not a malfunction. Retained images are not recorded on the SDHC card.
- Do not press against the surface with force or subject it to strong impact. Doing so may damage or break the screens.
- Noise may appear in the viewfinder when switching between the live video and playback images.  
Due to the characteristic of the viewfinder display device, colors may appear on the images when you blink your eyes. This is not a malfunction. It does not affect the recorded images, SDI output, or component output.

---

## Handling of SDHC Cards

■ The access lamp lights up in red when data on the SDHC card is being accessed. Do not remove the SDHC card during data access (such as recording, playback, or formatting). Do not turn off the power or remove the battery and AC adapter during access either.

■ Do not use or store the SDHC card in a place that is subject to static electricity or electrical noise.

■ Do not place the SDHC card near locations that are exposed to strong magnetic fields or radio waves.

■ Inserting the SDHC card incorrectly may result in damage of this unit or the SDHC card.

■ We are not liable for any accidental loss of data stored on the SDHC card. Please back up any important data.

■ Make use of the SDHC card within the prescribed conditions of use.

■ Do not use it at the following locations.

Places that are subject to direct sunlight, high humidity or corrosion, places near thermal equipment, sandy or dusty places, or in a car under the sun with the doors and windows closed.

■ Do not bend or drop the SDHC card, or subject it to strong impact or vibration.

■ When formatting or erasing data using the camera recorder, only the file administration information is changed. The data is not completely erased from the SDHC card. If you want to completely erase all of the data, we recommend either using commercially available software that is specially designed for that purpose, or by physically destroying the SDHC card with a hammer, etc.

■ Do not dismantle or modify the SDHC card.

■ Do not touch the terminals with your hands or with a metal object.

■ Do not allow dust, dirt, water, or foreign objects to adhere to the terminals.

■ Do not remove the labels or stick other labels or stickers on the SDHC cards.

■ Do not use pencils or ballpoint pens to write on the SDHC cards. Always use oil-based pens.

■ If you format (initialize) the SDHC card, all data recorded on the card, including video data and setup files, will be deleted.

■ You are recommended to use cards that are formatted (initialized) on this camera recorder.

- The SDHC card may be damaged if the camera recorder is not operated correctly. Formatting (Initializing) the SDHC card may allow it to operate correctly.
- SDHC cards that have been formatted (initialized) on other cameras, computers or peripheral equipment may not operate correctly. In this case, format (initialize) the SDHC card on this camera recorder.

---

## Characteristic CCD Phenomena

■ Smear and blooming

Due to the physical structure of CCDs, vertical streaking (called “smear”) may occur when shooting an extremely bright light source or expansion of light (called “blooming”) may appear around it. Although the CCD employed in this unit produces very little smear or blooming, these phenomena may still occur when shooting a bright light source.

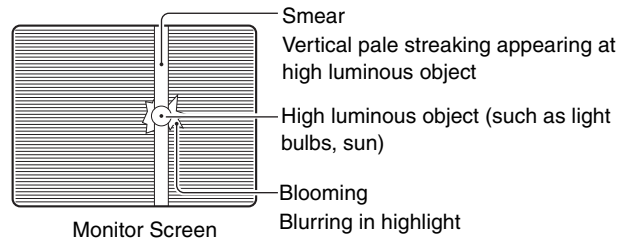

■ Moire or aliasing

Stripes, lines or other fine patterns may appear jagged when they are shot.

■ White dots

High temperatures can cause CCD sensor pixels to produce white dots in the image. This is especially prominent when boosting the sensitivity.

This is a characteristic of the charged-coupled device (CCD). As far as possible, use this unit under conditions where the temperature of this unit does not increase.

---

## Copyright

Any recordings made on this camera recorder that are played back for profit or public preview may infringe on the rights of the owner of the recordings.

Do not use the recordings for purpose other than personal enjoyment without prior consent from the owner.

# Introduction

## Operation Mode

This camera recorder has three operation modes - Camera mode, Media mode, and USB mode.

The operation mode indicator on the left side of the camera recorder lights up according to the mode. The AUX mode is only available on GY-HM790CHU/GY-HM790U.

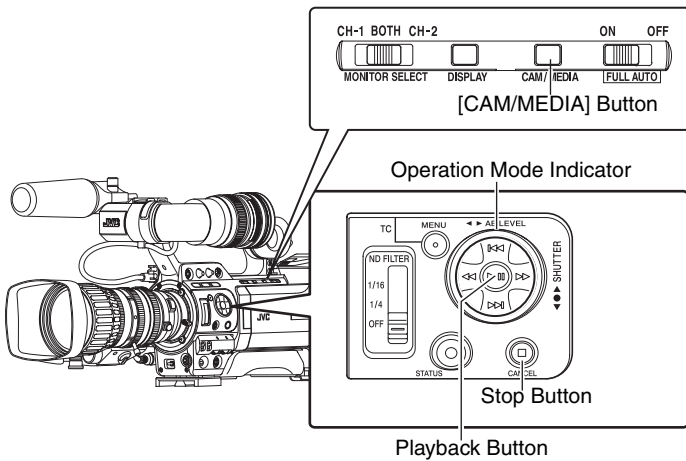
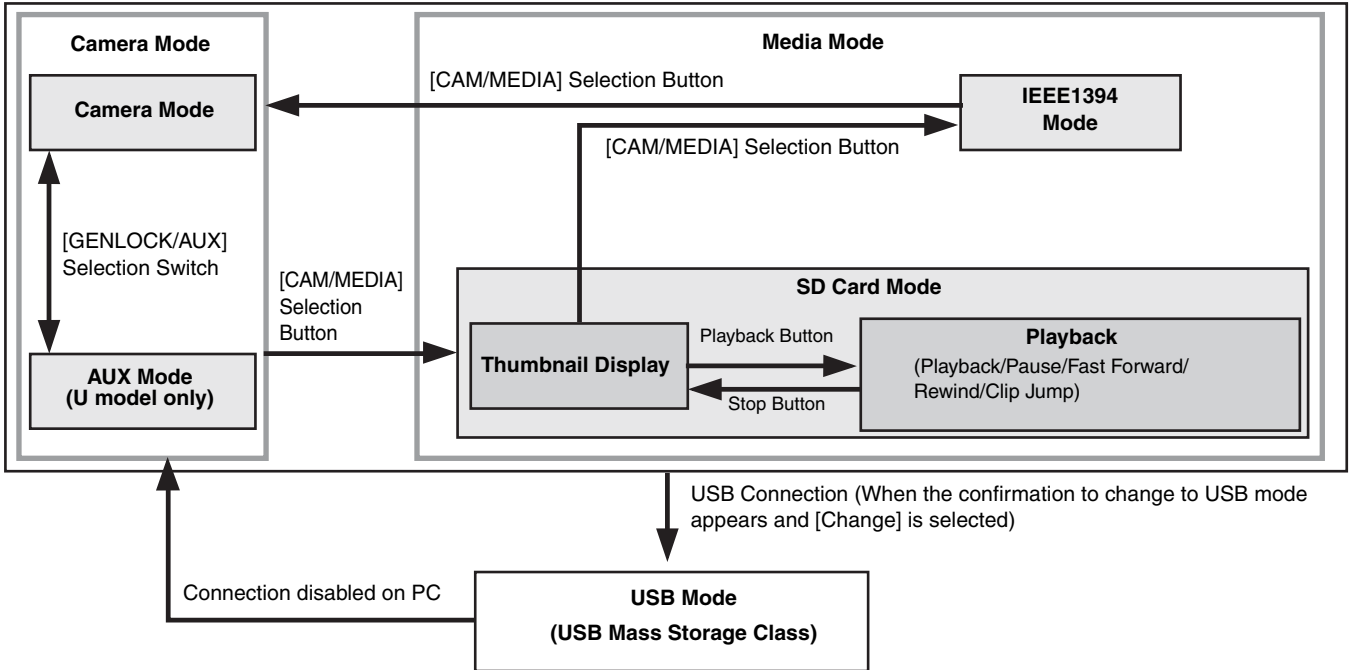



Operation Mode		Operation Mode Indicator	Description
Camera Mode	Camera Mode	Blue	This is the camera shooting mode. The camera recorder starts up in Camera mode when the power is turned on. <b>Memo :</b> <ul style="list-style-type: none"> <li>Images recorded on the SDHC card cannot be played back in this mode. However, you can check (play back) the most recently recorded image using the Clip Review function. (☞ Page 56)</li> </ul>
		Purple	When [Rec Mode] is set to “Variable Frame”, the operation mode indicator lights up in purple during Variable Frame REC in Camera mode. (☞ Page 60)
	AUX Mode (U model)	Blue	This is a mode for input and recording of composite video signals from an external device.
Media Mode	SD Card Mode	Green	This mode allows you to play back or delete clips recorded on the SDHC card. Press the [CAM/MEDIA] selection button to enter SD Card mode when you are not shooting in Camera mode. Once the camera recorder is in SD Card mode, thumbnails of the selected media slot are displayed.
	IEEE1394 Mode	Orange	This is the input mode for video images from the IEEE1394-connected equipment. The camera recorder enters IEEE1394 mode when you press the [CAM/MEDIA] selection button while the power of the equipment connected to the [IEEE1394] terminal is turned on during thumbnail display in Media mode (SD Card mode). (Only for HD video systems) When an SD video system is in use, availability of the [IEEE1394] terminal connection cannot be detected in Media mode (SD Card mode). Allow the camera recorder to detect the [IEEE1394] terminal connection in advance by turning on the power of the connected equipment in Camera mode. Once the camera recorder is in IEEE1394 mode, the playback images of the connected equipment are displayed. However, if the IEEE1394 connection is not recognized (such as when the power of the IEEE1394-connected equipment is not turned on), the camera recorder will switch to Camera mode instead. Press the [CAM/MEDIA] selection button during IEEE1394 mode to switch to Camera mode. If the power of the equipment connected to the [IEEE1394] terminal is OFF or if connection is canceled in IEEE1394 mode, the camera recorder will not automatically switch to other modes. To quit IEEE1394 mode, you must operate the [CAM/MEDIA] selection button. <b>Note :</b> <ul style="list-style-type: none"> <li>This mode is used for viewing images input to the [IEEE1394] terminal from an external device, and not intended for recording input images on the camera recorder.</li> </ul>
USB Mode		Orange	This mode allows you to connect to a PC and transfer the files on an SDHC card to the PC. When the camera recorder is connected to a USB cable, the message “Change to USB Mode” appears. Select [Change] and press the Set button to switch to USB mode. (☞ Page 130) In USB mode, the camera recorder is recognized by the connected PC as a peripheral drive (USB mass storage class only). Disable the connection on the PC and remove the USB cable from the camera recorder to switch to Camera mode. (☞ Page 130) <b>Memo :</b> <ul style="list-style-type: none"> <li>When a USB cable is connected, the message appears after recording stops.</li> <li>If playback is in progress, the message appears once the files are closed automatically, such as when playback stops.</li> </ul>

# Names of Parts

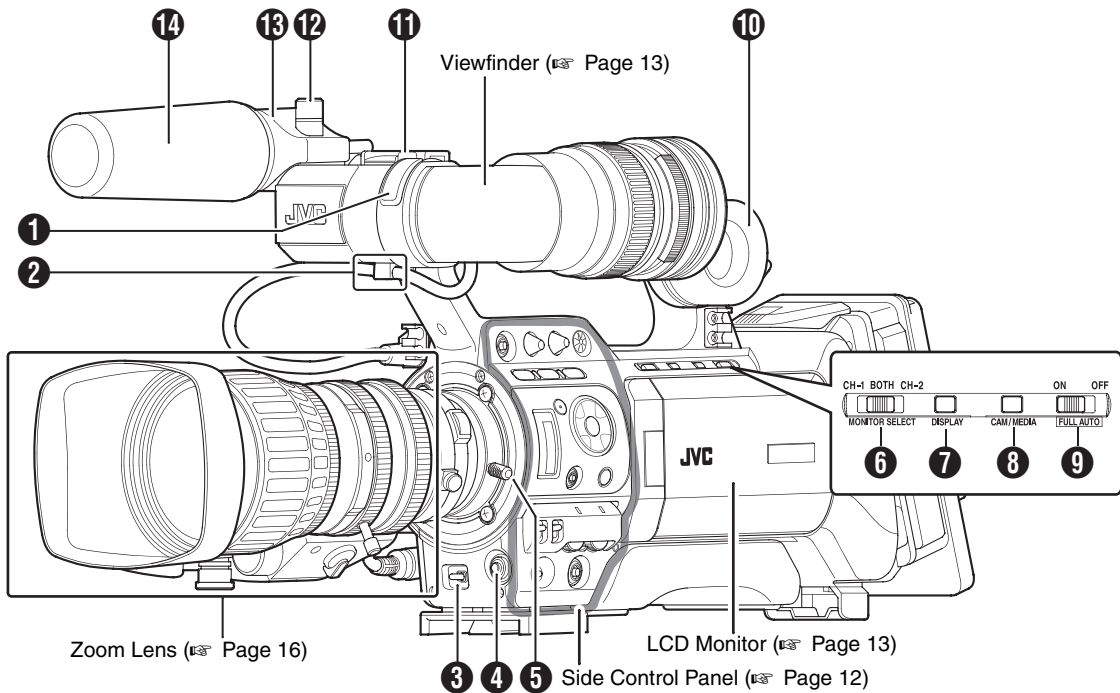

- 1 Front Tally Lamp** (☞ Page 30, 94)
- 2 Viewfinder Cable Clamp** (☞ Page 21)
- 3 [ZEBRA ON/OFF] Zebra ON/OFF Switch** (☞ Page 20)  
**[SKIN AREA/SPOT METER] Skin Area/Spot Meter Switch** (☞ Page 80)
- 4 [AWB] Auto White Balance Button** (☞ Page 42)
  - Setting the [WHT.BAL.] selection switch (☞ Page 12) **9** on the control panel on the right side of the camera recorder to “A” or “B” starts up the Auto White function.
  - If the [WHT.BAL.] selection switch (☞ Page 12) **9** is set to “PRESET”, you can switch the color temperature of the preset white balance.
- 5 Lens Lock Lever** (☞ Page 21)
- 6 [MONITOR SELECT] Audio Monitor Selection Switch** (☞ Page 46)
- 7 [DISPLAY] Display Button** (☞ Page 30)
- 8 [CAM/MEDIA] Camera/Media Mode Selection Button** (☞ Page 8)
- 9 [FULL AUTO] Full Auto Shooting (FAS) Switch** (☞ Page 81)
- 10 Monitor Speaker (Cheek Pad)** (☞ Page 27)
- 11 Shoe**  
For mounting separately sold lights and accessories.
- 12 Microphone Holder Lock Knob** (☞ Page 21)
- 13 Microphone Holder** (☞ Page 21)
- 14 Microphone** (☞ Page 21)

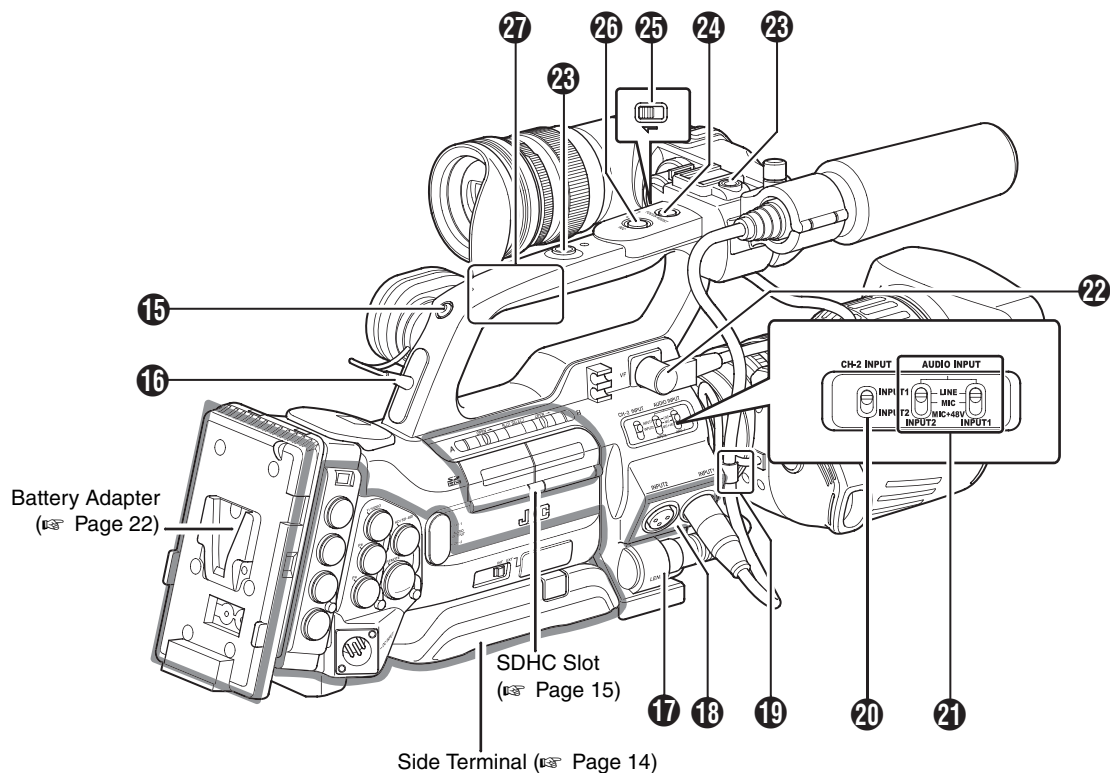

- 15 Back Tally Lamp (☞ Page 30, 94)
- 16 [PHONES] Earphone Connector (Φ3.5) (☞ Page 47)
- 17 [LENS] Lens Connector (12-pin Connector) (☞ Page 21)
- 18 [INPUT1/INPUT2] Audio Input Terminal 1, 2 (XLR 3-pin × 2) (☞ Page 46)
- 19 Microphone Cable Clamp (☞ Page 21)
- 20 [CH-2 INPUT] CH-2 Audio Input Terminal Selection Switch  
Select the audio input terminal to record to CH-2. (☞ Page 46)  
**Memo :** \_\_\_\_\_  
• Audio from [INPUT1] terminal is input to CH-1 regardless of the setting.
- 21 [AUDIO INPUT 1/2] Audio Input Signal Selection Switch (☞ Page 46)
- 22 Viewfinder Connector (20-pin) (☞ Page 21)
- 23 Accessory Mounting Screw Hole (x2)

- 24 [FOCUS ASSIST] Focus Assist Button (☞ Page 37)
- 25 Record Button Lock Switch  
Set the switch toward the lens to lock the [REC] trigger button 26.  
**Memo :** \_\_\_\_\_  
• The [REC] trigger button (☞ Page 12) 11 at the side control panel on the right of the camera recorder is not locked.
- 26 [REC] Rec Trigger Button (Recording Start/Stop)  
Starts/stops recording.  
**Memo :** \_\_\_\_\_  
• The [REC] trigger button (☞ Page 12) 11 at the side control panel on the right of the camera recorder is interlocked with this button.
- 27 Handle

# Names of Parts (continued)

## Side Control Panel

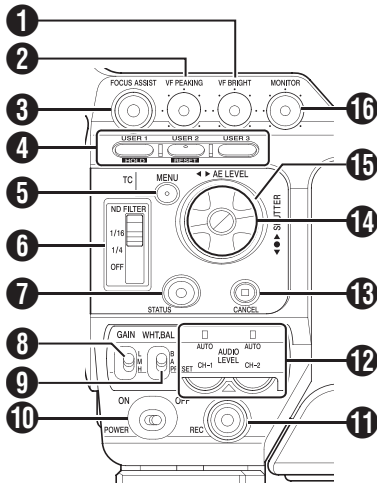

- 1 [VF BRIGHT] Viewfinder Luminance Adjustment Knob** (☞ Page 29)
- 2 [VF PEAKING] Contour Adjustment Knob** (☞ Page 29)

**Memo :** \_\_\_\_\_  
 • This knob does not function when Focus Assist is activated. (☞ Page 37)

- 3 [FOCUS ASSIST] Focus Assist Button**  
 Press this button during shooting to display the focus area in either blue, red, or green. This enables easy and accurate focusing. (☞ Page 37)
- 4 [USER1], [USER2], [USER3] User Buttons** (☞ Page 79)  
 Use these buttons to switch shooting conditions according to the object. The functions change as below according to the operation mode (☞ Page 8).

	During Camera mode (Except AUX mode)	During Media mode
<b>[USER1] Button</b>	<ul style="list-style-type: none"> <li>• Activates the function assigned to [USER1] in the menu.</li> <li>• Loads the [TC Preset] screen when pressed together with the [MENU] button. (☞ Page 51)</li> </ul>	Adds/deletes OK mark. (☞ Page 68)
<b>[USER2] Button</b>	<ul style="list-style-type: none"> <li>• Activates the function assigned to [USER2] in the menu.</li> <li>• Resets settings on the [TC Preset]/[UB Preset] screen when pressed. (☞ Page 51, 52)</li> </ul>	Deletes clips (☞ Page 66)
<b>[USER3] Button</b>	<ul style="list-style-type: none"> <li>• Activates the function assigned to [USER3] in the menu.</li> </ul>	—

**Memo :** \_\_\_\_\_  
 • Set the functions of the [USER1,USER2,USER3] buttons in the menu. (☞ Page 79)  
 • When the menu screen is displayed, these buttons function as the menu operation buttons. (☞ Page 70 [Operation Buttons])

- 5 [MENU] Menu Button** (☞ Page 70)
- 6 [ND FILTER] ND Filter Switch** (☞ Page 45)
- 7 [STATUS] Status Screen Display Button**
  - Press the [STATUS] button to display the status screen on the viewfinder and LCD monitor during normal screen display (when the menu screen is not displayed). (☞ Page 18 [Status Screen])
  - Switches between [Main Menu] and [Favorites Menu] when the [STATUS] button is pressed while the menu screen is displayed. (☞ Page 70)

- 8 [GAIN] Sensitivity Selection Switch** (☞ Page 40)
- 9 [WHT.BAL.] White Balance Selection Switch** (☞ Page 42)  
 You can select one of the three white balance types.

**10 [POWER] Power ON/OFF Switch**  
 Turns ON/OFF the power.  
 When the power is OFF, "POFF" appears on the LCD monitor and viewfinder.  
 Wait for 5 seconds or more to turn on the power again.

**11 [REC] Rec Trigger Button (Recording Start/Stop)**  
 Starts/stops recording.  
 The [REC] trigger button (☞ Page 11) **16** on top and the [REC] trigger button (☞ Page 16) of the lens are interlocked with this button.

**Memo :** \_\_\_\_\_  
 • When [1394 Rec Trigger] in the [Others] menu is set to "Split", this button becomes the recording start/stop button of the external equipment. (☞ Page 94) (☞ Page 124 [Backup Recording])

- 12 [AUDIO LEVEL CH-1/CH-2]/[AUTO] CH-1/CH-2 Recording Level Adjustment Knob/Auto Indicator** (☞ Page 46)
- 13 [CANCEL] Cancel Button**  
 Cancels various settings and stops playback.
- 14 Cross-Shaped Button (▲▼◀▶)/Set Button (●)**  
 The function changes according to the operation status of the camera recorder.
  - During menu operation (all modes) (☞ Page 70)
    - Center Set button (●) : Confirms menu items and setting values
    - Cross-Shaped Button (▲▼) : Selects menu items and setting values
  - During Camera mode (Except AUX mode)
    - Shutter operation:
      - Center Set button (●) : Shutter ON/OFF
      - Cross-Shaped Button (▲▼) : Switches shutter speed when shutter is ON
    - AE level operation : Cross-shaped button (◀▶)

**Memo :**

- When [Camera Function] menu → [Switch Set] → [AE LEVEL] is set to “AE LEVEL/VFR”, the cross-shaped button (◀▶) is used to set the number of frames during Variable Frame Rec.  
(☞ Page 60 [Variable Frame Rec])  
(☞ Page 80 [AE LEVEL])

■ During Media mode (SD Card mode) (☞ Page 61)  
Thumbnail operation : Cross-shaped button (▲▼▶◀), center Set button (●)

**15 Operation Mode Indicator**

Lights up as below according to the operation mode.  
(☞ Page 8)

Operation Mode	Color
Camera Mode (Except AUX mode)	Blue/Purple
AUX Mode (U model only)	Blue
Media Mode (SD Card Mode)	Green
Media Mode (IEEE1394 Mode)	Orange
USB Mode	Orange

**Memo :**

- You can select whether to light up the indicator using [Mode LED] in the [Others] menu. (☞ Page 94)

**16 [MONITOR] Audio Monitor Level Adjustment Knob**

For adjusting the volume of the monitor speaker and earphones.

**Viewfinder**

(☞ Page 29)

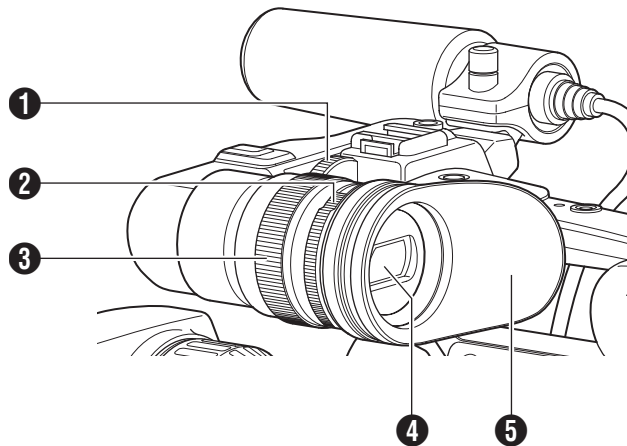

**1 Viewfinder Slide Lock Ring**

For loosening the ring and adjusting the position of the viewfinder 5 to the left or right.

**2 Eyepiece Focus Ring**

For adjusting the visibility.

**3 Viewfinder Eyepiece Lock Ring**

For loosening the ring and adjusting the eyepiece position of the viewfinder to the front or back.

**4 Viewfinder**

**5 Eyepiece**

Prevents external light from entering the viewfinder screen and cameraman’s vision.

**LCD Monitor**

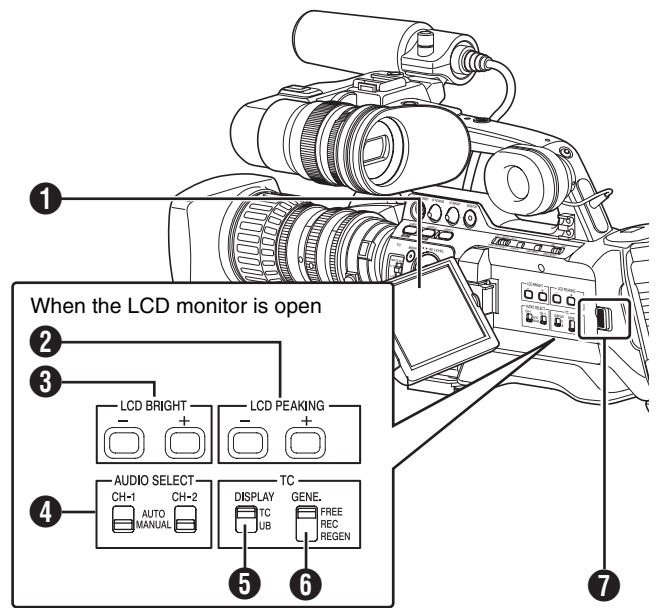

**1 LCD Monitor (☞ Page 28)**

**2 [LCD PEAKING +/-] LCD Contour Adjustment Button (☞ Page 28)**

**3 [LCD BRIGHT +/-] LCD Display Brightness Adjustment Button (☞ Page 28)**

**4 [AUDIO SELECT CH-1/CH-2] Audio Recording Mode Switch (☞ Page 46)**

**5 [TC DISPLAY] TC/UB Display Switch (☞ Page 48)**

**6 [TC GENE.] Time Code Generator Switch (☞ Page 48)**

**7 LCD Cover Lock Release Knob (☞ Page 28)**

# Names of Parts (continued)

## Side Terminal

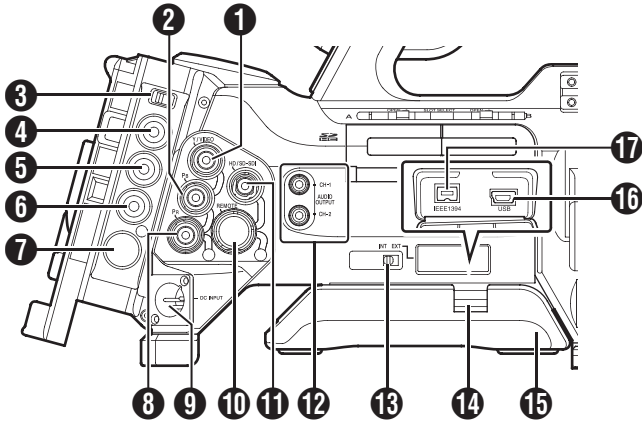

**1** [Y/VIDEO] Y/Composite Video Signal Output Terminal (BNC) (☞ Page 122)

**2** [PB] PB Video Signal Output Terminal (BNC) (☞ Page 122)

**3** [GENLOCK/AUX] Genlock/AUX Selection Switch (U model only) (☞ Page 125)

**4** [GENLOCK/AUX IN] Genlock/AUX Input Terminal (U model)/[GENLOCK INPUT] Genlock Input Terminal (E model)

U model : For input of external synchronizing signals or external composite video signals. (☞ Page 125 [Input of Composite Video Signals from External Device (GY-HM790CHU/GY-HM790U only)])

E model : For input of external synchronizing signals. (☞ Page 126 [Input of External Synchronizing Signal (Genlock)])

**5** [TC IN] Time Code Input Terminal (BNC) (☞ Page 48 to 52)

**6** [TC OUT] Time Code Output Terminal (BNC) (☞ Page 48 to 52)

**7** [STUDIO] Studio Terminal (10-pin) (☞ Page 128)

Connect to this terminal when combining the use of products, such as a transmission unit, from a different manufacturer.

Pin No.	Signal	Input/Output
1	NC	—
2	CALL TALLY	IN
3	RM TALLY	OUT
4	RM PREVIEW	OUT
5	NC	—
6	NC	—
7	TALLY IN	IN
8	RETURN GND	—
9	RETURN IN	IN
10	GND	—

**8** [PR] PR Video Signal Output Terminal (BNC) (☞ Page 122)

**9** [DC INPUT] DC Input Terminal (☞ Page 22)

Input terminal for DC 12 V power supply. Connects with an AC adapter.

**10** [REMOTE] Remote Terminal (☞ Page 131)

**11** [HD/SD-SDI] HD/SD-SDI Output Terminal (BNC) (☞ Page 122)

**12** [AUDIO OUTPUT CH-1/CH-2] Audio Output Terminal (RCA)

Output terminal for audio signals.

- Input audio signals are output during Camera mode.
- Playback audio signals are output during Media mode.
- Audio from input audio signals is output during HD/DV signal (IEEE1394) input.

**Memo :** \_\_\_\_\_

- Alarm tone is not output.

**13** [INT/EXT] IEEE1394 Interface Terminal Switch (☞ Page 123)

For selecting a valid IEEE1394 interface terminal.

[EXT] : Enables IEEE1394 signals from the [IEEE1394] terminal **17**.

[INT] : Enables the accessory connector **2** at the rear of the camera recorder. (☞ Page 15)

**14** Shoulder Pad Slide Button

For adjusting the shoulder pad position. Press this button to adjust the shoulder pad **15** position to the front or back.

**15** Shoulder Pad

**16** [USB] USB Terminal (☞ Page 130)

**17** [IEEE1394] IEEE1394 Terminal (4-pin)

For connecting digital video equipment with IEEE1394 terminal using an IEEE1394 cable (sold separately).

To enable this terminal, set the [INT/EXT] IEEE1394 terminal switch **13** to [EXT].

(☞ Page 123 [IEEE1394 Connection])

**Note :** \_\_\_\_\_

- When connecting IEEE1394 cables, check that the connectors are facing the right direction before you insert.

**Memo :** \_\_\_\_\_

- Put on the covers when the connectors are not in use.

## SD Slot

(☞ Page 31)

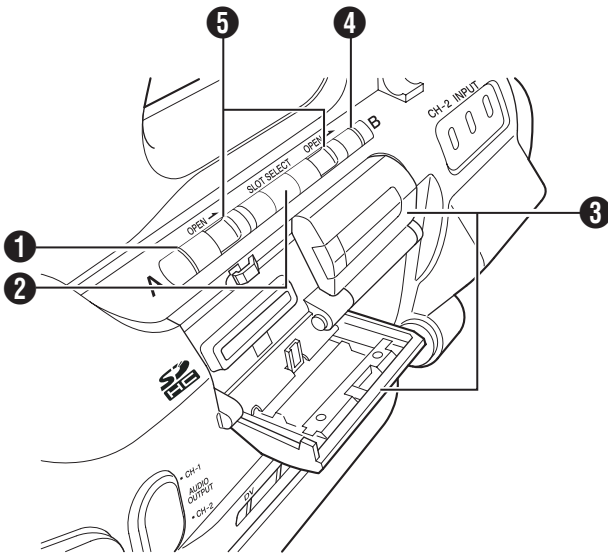

- ❶ Card Slot A Status Indicator
- ❷ [SLOT SELECT] Card Slot Selection Button  
For switching SDHC cards.
- ❸ SDHC Card Cover
- ❹ Card Slot B Status Indicator
- ❺ [OPEN] SDHC Card Cover Open/Close Knob

## Rear

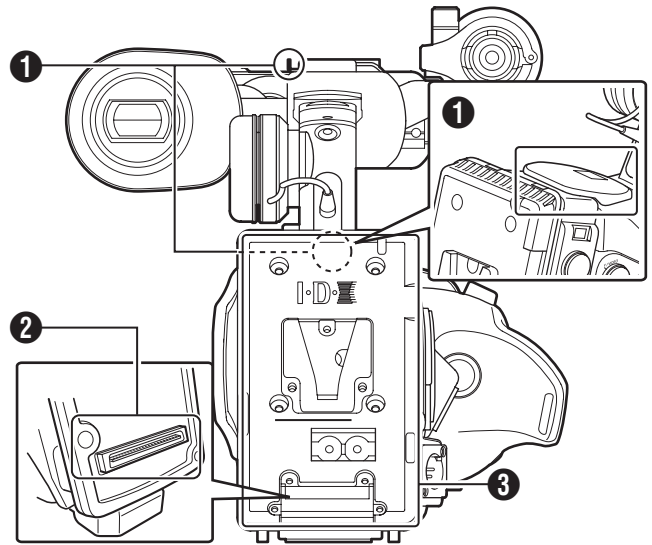

### ❶ Shoulder Belt Mount (x2)

For mounting a shoulder belt (sold separately).

#### Note :

- Be sure to use a shoulder belt with the strength to withstand the weight of this camera recorder.
- If the shoulder belt is not properly attached, the camera recorder may fall and cause injuries.
- Check the instruction manual provided with the shoulder belt before using.

### ❷ Accessory Connection Terminal

Terminal for connecting a KA-MR100G (Memory Recorder : sold separately) or KA-M790G (Multicore Remote Adapter : sold separately) unit.

#### Memo :

- When using this terminal, make sure that the Battery Adapter ❸ is removed.

### ❸ Battery Adapter (☞ Page 22)

The shape is different for GY-HM790CHU/GY-HM790U and GY-HM790CHE/GY-HM790E.

\* The above is the illustration for GY-HM790CHE/GY-HM790E.



## Names of Parts (continued)

### Zoom Lens

(Supplied with GY-HM790U/GY-HM790E only)

CANON KT14 x 4.4KRSJ

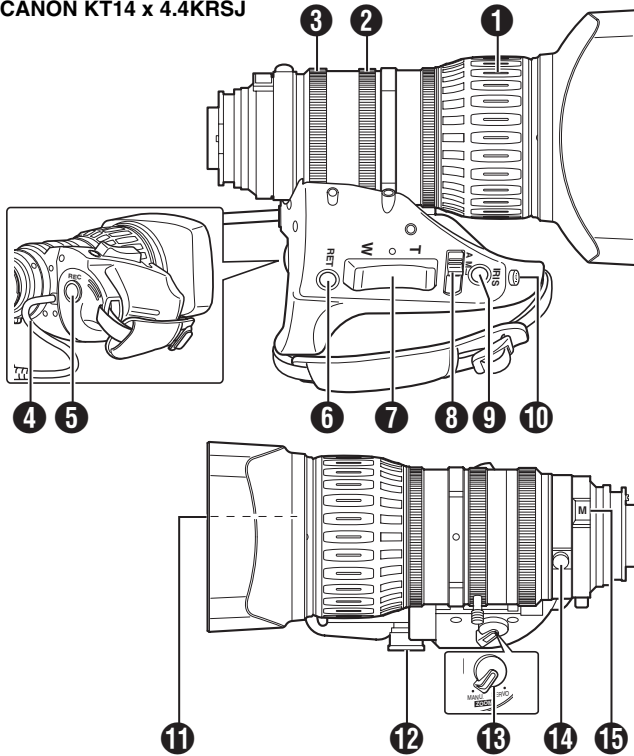

**1 Focus Ring**

**2 Zoom Lever/Ring**

To operate zoom with this lever, turn the [ZOOM] switch **13** and set it to "MANU."

**3 Iris Ring**

To operate auto iris, set the iris mode switch **8** to "A".

**4 Lens Cable**

**5 [REC] Record Trigger Button**

Starts/stops recording.

**6 [RET] Return Video Button**

Press this button to play back and check the latest clip, according to the settings under [Clip Review] of [Switch Set] in the [Camera Function] menu. (☞ Page 79)  
(☞ Page 56 [Viewing Recorded Videos Immediately (Clip Review)])

**Memo :** \_\_\_\_\_

- When [LENS RET] of [Switch Set...] in the [Camera Function] menu is set to "Focus Assist", this button functions as the Focus Assist button. When it is set to "Return", a return video is displayed. (☞ Page 79)

**7 Zoom Servo Control Lever**

To operate zoom servo with the zoom servo control lever, set the [ZOOM] switch **13** to "SERVO".

- Zooms into wide angle and increases the angle of view when "W" is pressed.
- Zooms into telephoto and decreases the angle of view when "T" is pressed.
- Zoom speed increases when the lever is pressed hard.

**8 Iris Mode Switch**

- A : Auto iris operation mode.
- M : Manual iris operation mode.

**9 Iris Momentary Button**

Press and hold this button to change to auto iris mode when the iris mode switch **8** is set at "M".

**10 [I.G.] Iris Speed Adjustment Knob**

If the speed is set too fast, opening/closing of the iris becomes unstable and hunting may occur. Readjust the speed in this case.

**11 Filter Built-In Screw**

A transparent or UV filter for lens protection can be installed inside the lens hood from the front. Filters for various effects can also be used.

- Installable filter types

- When installed on the hood : 82 mm P0.75
- When installed on the lens body : 72 mm P0.75

**12 Zoom Servo Connector**

For connecting a zoom servo unit (sold separately).

**13 [ZOOM] Zoom Switch**

- SERVO : Enables zooming with the zoom servo control lever **7**.
- MANU. : Enables zooming with the zoom lever/ring **2**.

**14 Back Focus Ring/Lock Screw**

Exclusive ring for adjusting the back focus. After adjusting, secure with a lock screw.  
(☞ Page 28 [Adjusting Back Focus])

**15 [M] Macro Focus Ring (for close-ups)**

Turn the ring in the direction of the arrow to take close-up shots of small objects.  
Normal focusing and zooming cannot be performed in macro mode.

**To take macro shots**

- Set focus ring **1** to infinity ( $\infty$ ).
- Set zoom ring **2** to the maximum wide angle.
- Rotate this ring in the direction of the arrow to adjust focus on the object.

**Note :** \_\_\_\_\_

- As the back focus knob is located nearby, be careful not to mistake the two knobs.
- Do not forget to restore the macro ring to its original position after use. (☞ Page 28 [Adjusting Back Focus])



# Basic System Diagram

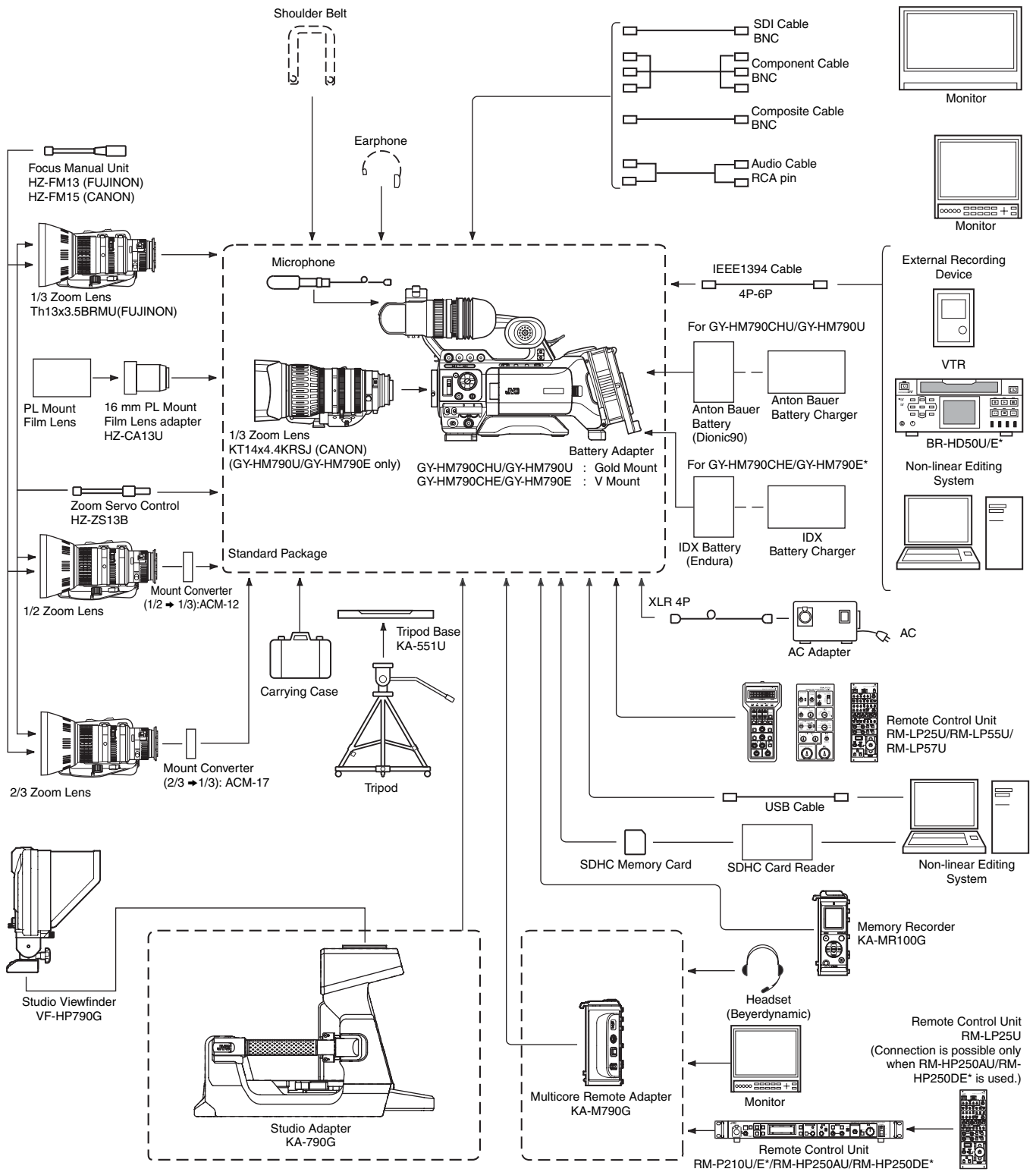

\* Models with an E suffix are for the European market and the UL Listing mark is not applicable.

# Displays on the LCD Monitor and Viewfinder

You can display the camera status, media information, zebra pattern, and various markers in the video image on the LCD monitor and viewfinder screens during shooting. Besides camera and playback images, the following characters are displayed on the LCD monitor and viewfinder.

- Status screen (Page 18)
- Auto White display\* (Page 20)
- Menu setting screen (Page 20)
- Alarm display (Page 20)
- Marker and safety zone indicators\* (Page 112)
- Zebra pattern display (Page 20)

\* Displayed in Camera mode only (Except AUX mode)

**Memo :**

- When [Analog Out Char.]/[SDI Out Char.] in the [A/V Out] menu is set to "On", the status screen and menu screen are also displayed in the video image of the video signal output terminal. (Page 92)

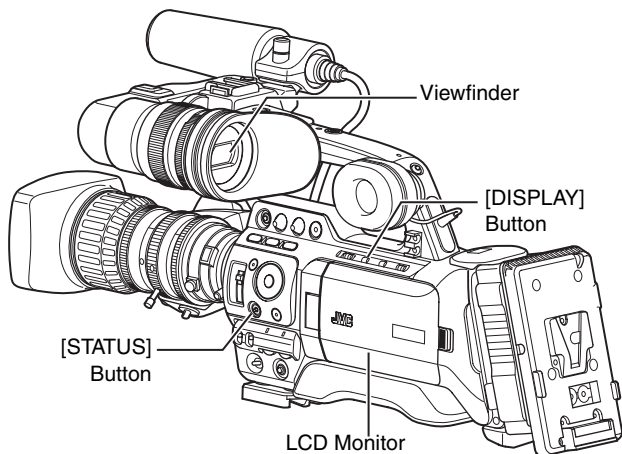

## Status Screen

This screen allows you to check the current settings. To display the status screen, press the [STATUS] button in the normal screen. The status display differs according to the operation mode (4 types). (Page 8 [Operation Mode])

### Status Screen in Camera Mode (Page 102)

#### Viewfinder display

The display switches between the 5 screen types with every press of the [STATUS] button. (STATUS 0 → 1 → 2 → 3 → 4 → 0)

\* The STATUS 0 screen is skipped in the AUX mode (U model only).

## LCD monitor display

The display switches between the 5 screen types with every press of the [STATUS] button. (STATUS 0 → 1 → 2 → 3 → 4 → 0) Press the [DISPLAY] button to switch to the enlarged status display screen. (Page 19)

\* The STATUS 0 screen is skipped in the AUX mode (U model only).

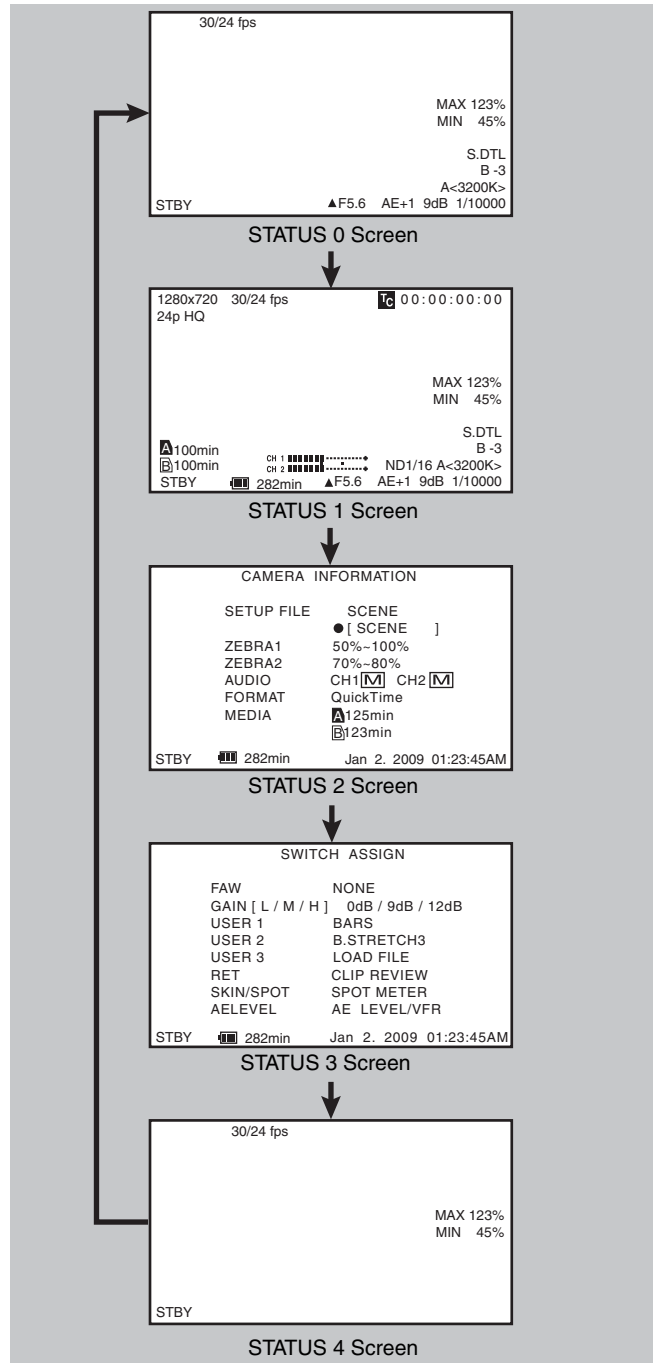

Press [DISPLAY] ↑ ↓ Press [DISPLAY]

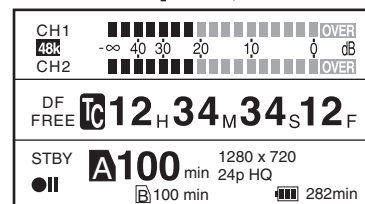

STATUS 1 Enlarged Display Screen (LCD monitor only)

**■ Status Screen (VF/LCD) During Clip Playback in Media Mode (SD Card Mode)**  
 (☞ Page 108)

The display switches between the 3 screen types with every press of the [STATUS] button. (STATUS 0 → 1 → 2 → 0)

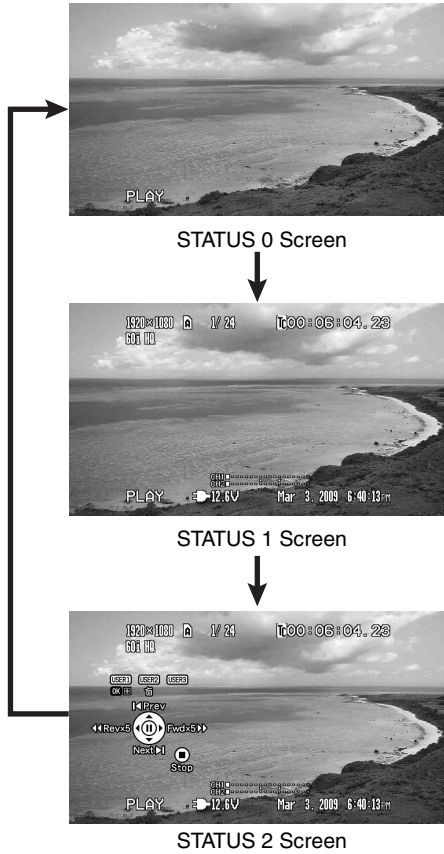

**■ Status Screen in Media Mode (IEEE1394 Mode) (☞ Page 109)**

The display switches between the 2 screen types with every press of the [STATUS] button. (STATUS 0 → 1 → 0)

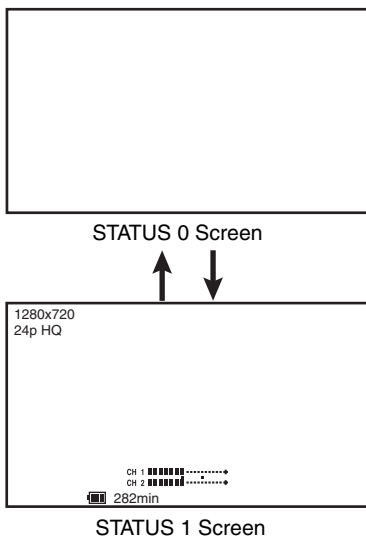

**■ Status Screen in USB Mode**

This screen displays the USB mode.

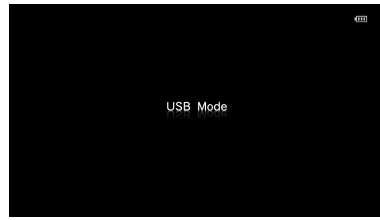

**Enlarged Status Display on LCD Monitor**

You can enlarge and display only the characters of the status screen on the LCD monitor. (Camera mode only)

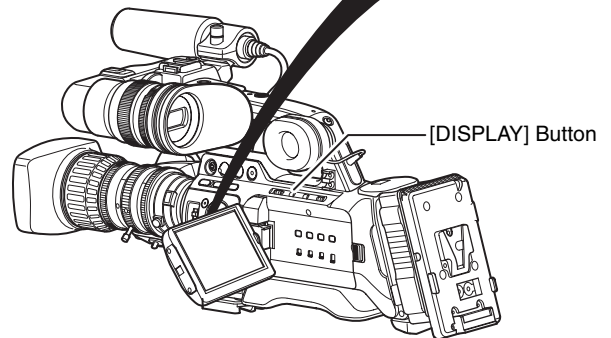
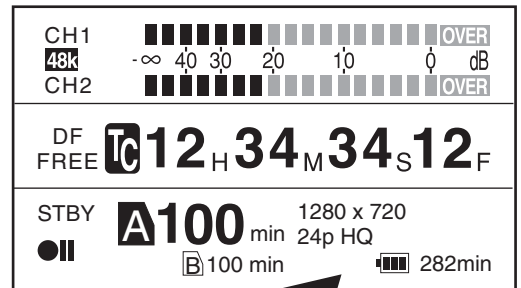

**1** Set [LCD + VF] in the [LCD/VF] menu to "On".  
 (☞ Page 88)

**2** Press the [DISPLAY] button while the LCD screen is displayed.

The display switches between the same display as the viewfinder and the enlarged display with every press of the button.

**Memo :** \_\_\_\_\_

- During enlarged display of the status on the LCD monitor screen, the video image remains displayed on the viewfinder.

## Displays on the LCD Monitor and Viewfinder (continued)

### Auto White Display (Camera Mode Only, Excluding AUX Mode)

Displays the operation and result when Auto White Balance is activated.

(☞ Page 42 [Adjusting the White Balance])

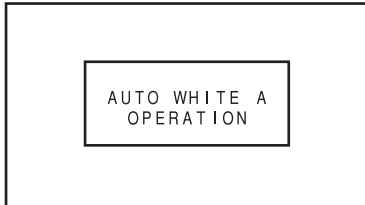

### Menu Setting Screen

For configuring various settings.

Press the [MENU] button to display the menu setting screen.

(☞ Page 70 [Basic Operations in Menu Screen])

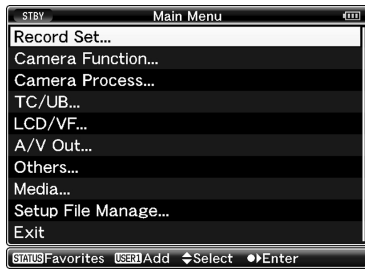

[Main Menu] Screen

### Alarm Display

- Alarm is displayed during the status screen display in Camera mode (STATUS 0, 1, 4) and Media mode. If the alarm sounds during STATUS 2 or 3 screen display in Camera mode, the display will return to STATUS 0 screen and alarm will be displayed.

(☞ Page 134 [Error Displays and Actions])

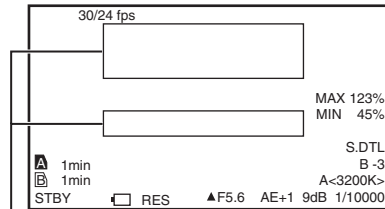

Alarm Display Area

### Zebra Pattern Display

Two types of zebra patterns that indicate the luminance level of the video image can be displayed on this camera recorder. You can set the luminance levels for displaying the two types of zebra patterns.

(☞ Page 54 [Setting Zebra Pattern])

Zebra Pattern



#### Memo :

- Use the [ZEBRA ON/OFF] switch in front to turn ON/OFF the zebra pattern display.
- Set the display pattern and luminance level in [LCD/VF] menu → [Shooting Assist] → [Zebra]. (☞ Page 89)

## Attaching Accessories

### Attaching the Zoom Lens

(Supplied with GY-HM790U/GY-HM790E only)

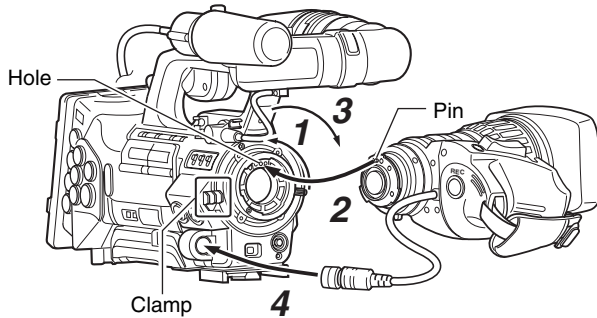

- 1** Loosen the mount ring.
- 2** Attach the zoom lens such that the pin matches the hole of the mounting area.
- 3** Tighten the mount ring.
- 4** Connect the cable connector.
- 5** Attach the lens cable to the clamp.

**Memo :**

- Tighten the mount ring completely. If it is not fully tightened, the lens may drop or the back focus may be out of alignment.
- When attaching or removing the zoom lens, set the [POWER] switch of the camera recorder to "OFF".

### Attaching the Microphone (Supplied)

You can attach the supplied microphone to the microphone holder.

The supplied microphone has a phantom power supply.

- 1** Turn the knob on the microphone holder anticlockwise to loosen and open the microphone holder.
- 2** Place the microphone in the microphone holder.
- 3** Turn the knob on the microphone holder clockwise to secure the microphone.
- 4** Connect the microphone cable to the [INPUT1] or [INPUT2] terminal.
- 5** Pin the microphone cable to the clamp.
- 6** Make sure to perform the correct settings for the phantom microphone (☞ Page 46).

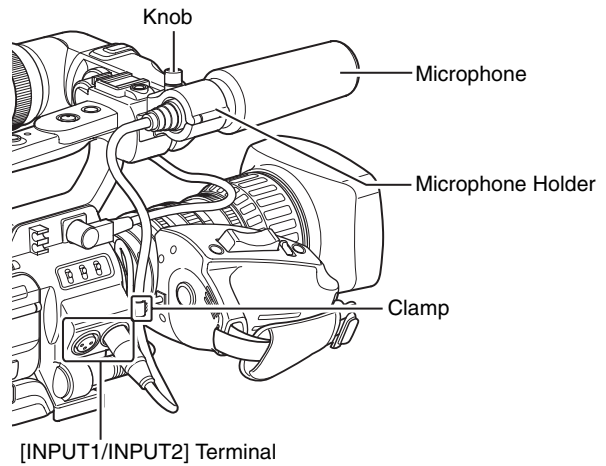

### Attaching the Viewfinder (Supplied)

- 1** Slide the viewfinder in the direction of the arrow to attach it.
- 2** Turn the slide lock ring to secure the position of the viewfinder.

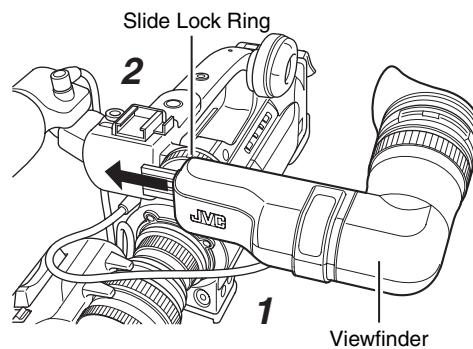

- 3** Attach the viewfinder cable to the viewfinder terminal.
- 4** Pin the viewfinder cable to the clamp.

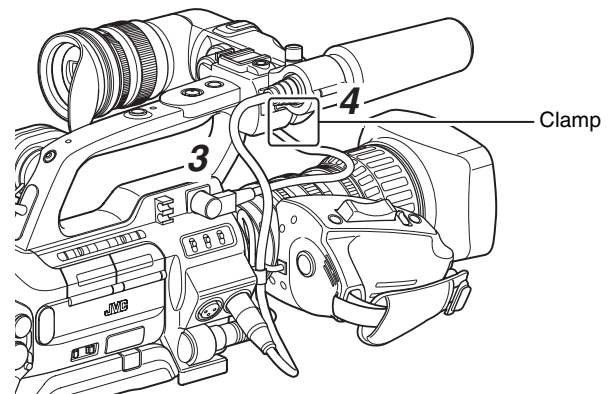

## Preparations

### Power Supply

To use this camera recorder, you can attach a battery pack or connect an AC adapter to it.

(☞ Page 22 [Using a Battery Pack])

(☞ Page 22 [Using AC Power (DC IN Power)])

#### Note :

- Set the [POWER] switch to “OFF” before changing the power supply that operates this camera recorder.

### Using AC Power (DC IN Power)

Use an AC adapter (sold separately) to operate the camera recorder with AC power.

#### 1 Connect the DC cable of the AC adapter to the [DC INPUT] terminal of the camera recorder.

Check that the power of the camera recorder and the AC adapter is turned “OFF” and connect as shown in the diagram.

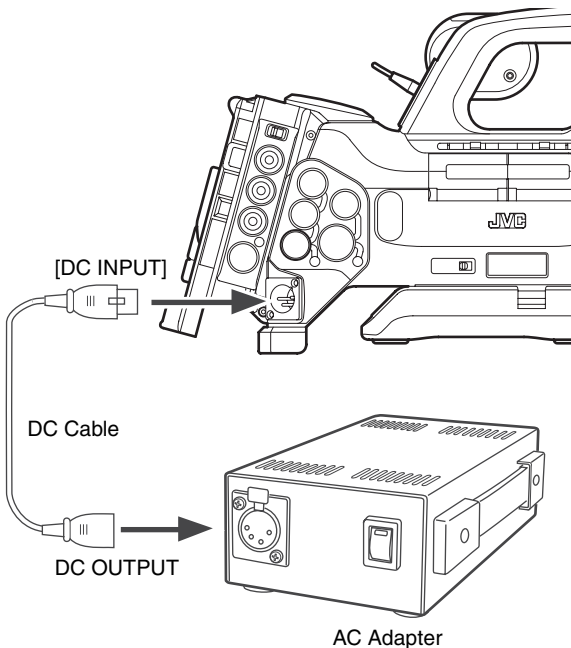

#### 2 Set the [POWER] switch of the camera recorder to “ON” after turning on the AC adapter.

Power will be supplied to the camera recorder.

#### Note :

- Do not insert or remove the DC cable during recording.
- Do not use power supply of high voltage fluctuation, containing noise such as ripple, or with insufficient capacity.

### Charging the Built-In Battery

The date/time and time code data are stored using the built-in rechargeable battery.

When power is connected to the camera recorder, the built-in battery always gets charged. When the power is disconnected, the battery gradually discharges.

The battery will be totally discharged if left unused for 3 months and the date/time and time code data will be reset.

When this happens, set the [POWER] switch to “ON” to display the [Initial Setting] screen, then set the date/time.

(☞ Page 26 [Setting the Clock (Initial Setting)])

### Using a Battery Pack

#### Recommended Batteries

U model : Dionic90 (Anton Bauer)

E model : Endura-HL9 (IDX)

\* Models with an E suffix are for the European market and the UL Listing mark is not applicable.

#### Note :

- Make use of the recommended batteries. Heavy batteries may fall off if not used correctly.
- See the battery instruction manual on how to charge the battery.

#### Battery Operating Time

The following are the approximate times for continuous operation on fully-charged batteries.

Battery	Continuous Operating Time (At 25 °C)
Dionic90 (U model)	Approx. 2.75 h
Endura-HL9 (E model)	Approx. 2.75 h

#### Memo :

- Actual operating times may differ depending on the age of the battery, charging condition, and operating environment.
- Operating time is shortened in cold environment.
- The operating time may shorten when power zoom is used, accessories are connected, or when the LCD monitor is frequently used.



## Precautions for the Battery Operation

- Do not remove the battery when the [POWER] switch is "ON".
- Do not insert or remove the DC cable when the battery is in use.
- Leaving the camera recorder unused with the battery inside will deplete the battery power even if you set the [POWER] switch to "OFF". Remove the battery if you are not using the camera recorder.

## Attaching the Battery (GY-HM790CHU/GY-HM790U)

Use the Dionic90 (Anton Bauer) battery.

**1** Align the battery guide pins (x3) with the battery, adapter, and guide hole, and insert straight.

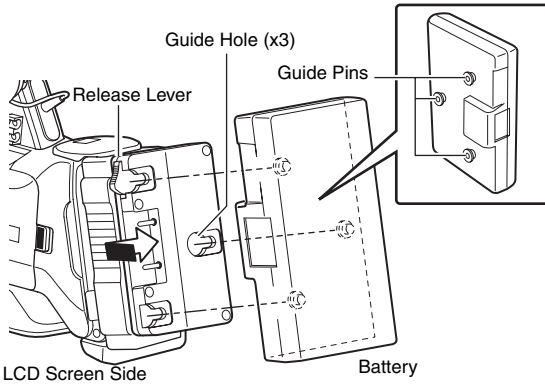

### Memo :

- If the guide pins are not inserted straight, the battery will not be attached correctly.

**2** Slide the battery toward the SDHC card cover side panel until it snaps into place.

### ■ Detaching the Battery

Press down the release lever and slide the battery toward you to detach it from the camera recorder.

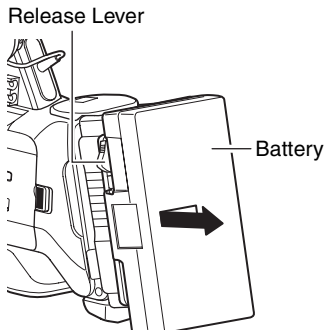

## Attaching the Battery (GY-HM790CHE/GY-HM790E)

Use the Endura-HL9 (IDX) battery.

**1** Attach the battery

Face the terminal downward and attach the V mount of the battery onto the V mount attachment bracket of the camera recorder.

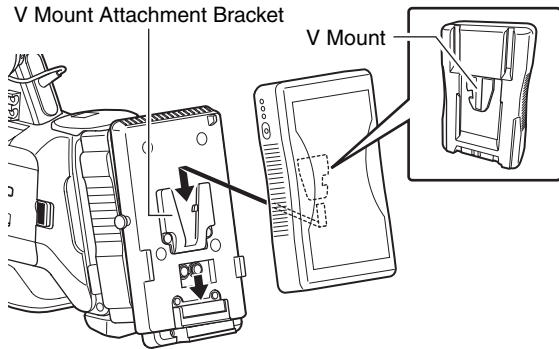

**2** Press down the battery until it snaps into place.

### ■ Detaching the Battery

Press down the release lever and slide the battery upward to detach it from the camera recorder.

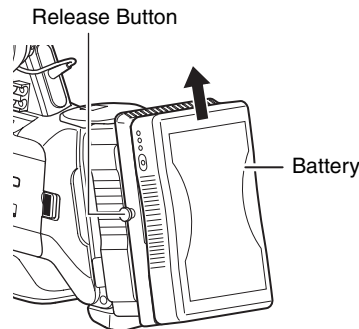

# Using a Battery Pack (continued)

## Power Status Display

### Viewfinder and LCD Monitor Screens

The power status is displayed on the status and menu screens. If the battery or supplied voltage from the AC adapter is low, a warning will be displayed in red.

**Note :** \_\_\_\_\_

- If the battery in use is not a recommended one, the battery mark which indicates the battery level may not appear.

### Status Screen

( Page 102 [Status Screen in Camera Mode])

( Page 108 [Status Screen in SD Card Mode])

( Page 109 [Status Screen in IEEE1394 Input Mode])

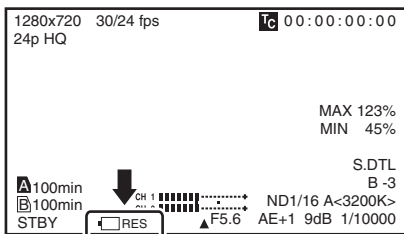

### Enlarged status display on the LCD monitor

( Page 110)

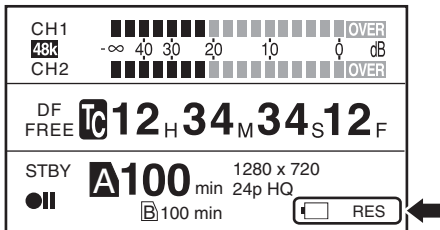

### Menu screen ( Page 70)

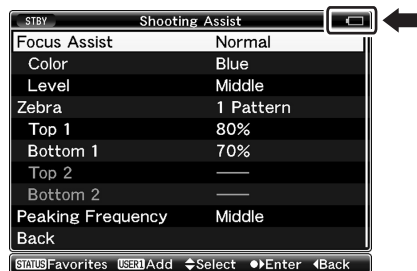

## Warnings by Lamps and Alarm Tones

- Warning status is indicated by tally lamps and alarm tones.
  - The front and back tally lamps of the camera recorder blink.
  - Alarm tone is output from the monitor speaker or [PHONES] terminal.

**Memo :** \_\_\_\_\_

- If you continue to use the camera recorder while the power warning is displayed, the camera recorder will stop automatically when the battery or supplied voltage from the AC adapter becomes lower.
- Alarm tone is not output during recording.

**Note :** \_\_\_\_\_

- The remaining battery power and time are displayed as there are from the battery information. Accurate data may not be displayed according to the battery condition. Replace the battery as soon as possible when the remaining battery power and time are low.

## Precautions for Batteries

- Store the battery in a cool and dry place when not in use. Do not expose the battery to high temperatures (such as in a car under direct sunlight). This will cause battery leakage and shorten the battery life.
- Operating time is shortened if the battery terminal is dirty.
- If the operating time shortens drastically even after charging, the battery may be reaching the end of its life. Replace the battery with a new one.

## Charging

- Use up the charge completely before you charge the battery. If the battery is not fully discharged before charging, the battery capacity may drop after repeated cycles.
- If the battery capacity drops due to repetitive shallow charging and discharging, it may be recovered by using up the charge completely and then fully charging the battery again.
- If you charge the battery immediately after using while the battery is still warm, it may not be fully charged.
- It is recommended that you charge the battery in an environment between 10 °C and 35 °C. The battery may not be fully charged or the charging time may be prolonged if charged under low temperatures (below 10 °C).



# Turning On/Off the Power

## Turning On the Power

### 1 Set the [POWER] switch to "ON".

The camera recorder starts up in Camera mode.

#### Memo :

- The camera recorder always start up in Camera mode when the [POWER] switch is set to "ON".
- Press the [CAM/MEDIA] button to switch to a different mode. The operation mode indicator changes as below. While in the Camera mode, setting the [GENLOCK/AUX] selection switch to "AUX" switches the camera recorder to the AUX mode. (U model only)  
See [Operation Mode] (Page 8) for details of each operation mode.
- During Camera mode (Except AUX mode) : Lights up in blue/purple mode)
- AUX Mode (U model only) : Blue
- During Media mode (SD Card mode) : Lights up in green
- Media Mode (IEEE1394 Input Mode) : Lights up in orange
- During USB mode : Lights up in orange
- During mode switching : Blinks in the color of the new mode

#### Memo :

- The camera recorder will switch to IEEE1394 Input mode only when the IEEE1394-connected equipment is in operation.

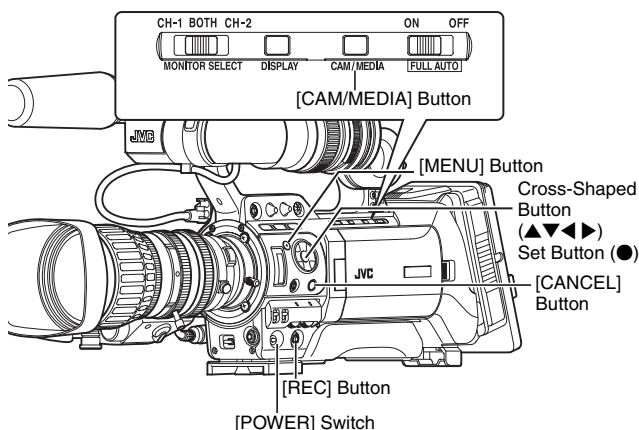

## ■ Camera Mode (Except AUX Mode)

Camera images are output on the viewfinder and LCD monitor. When a recordable SDHC card is inserted, the camera recorder enters the recording standby mode. "STBY" appears on the operation mode display area of the LCD monitor and viewfinder.

Press the [REC] trigger button to start recording.

#### Memo :

- Playback of SDHC card is not possible in Camera mode. However, you can use the Clip Review function to check the most recently recorded video clip. (Page 56)

## ■ AUX Mode (U model only)

This is a mode for recording composite videos from an external device. When a recordable SDHC card is inserted, the camera recorder enters the recording standby mode.

Press the [REC] trigger button to start recording.

Composite videos from the external device are output to the viewfinder and LCD monitor.

#### Memo :

- [System Definition] is fixed at "SD (DV)" in the AUX mode. (Page 56)

## ■ Media Mode (SD Card Mode)

This mode allows you to play back or delete clips recorded on the SDHC card.

When a playable SDHC card is inserted, the thumbnail or playback screen is output on the viewfinder and LCD monitor.

## ■ Media Mode (IEEE1394 Input Mode)

This mode allows you to check IEEE1394 input signals.

When playable IEEE1394 signals are input, input images are output on the viewfinder and LCD monitor. IEEE1394 input signals cannot be recorded.

## Turning Off the Power

Set the camera recorder to the recording standby or stop mode.

### 1 Set the [POWER] switch to "OFF".

### 2 Remove the battery and the power to the [DC INPUT] terminal (when not in use for a long time).

#### Note :

- Do not set the [POWER] switch to "OFF" during recording. Check that the operation mode display is "STBY" or "STOP" before you turn off the power.
- If you have mistakenly set the [POWER] switch to "OFF" during recording, wait for 5 seconds or more before you turn on the power again.
- When turning off the power, first set the [POWER] switch of the camera recorder to "OFF". Do not remove the battery or turn off the AC power while the [POWER] switch is set to "ON".

## Preparations

### Setting the Clock (Initial Setting)

Set the date/time of the built-in clock in the [Initial Setting] screen. The configured date/time data is saved in the built-in rechargeable battery even if the power is turned off.

#### Setting the Clock in the [Initial Setting] Screen

The [Initial Setting] screen appears when the power is turned on for the first time and when the built-in battery is turned on again after being fully discharged.

All operations are disabled until initial settings are complete.

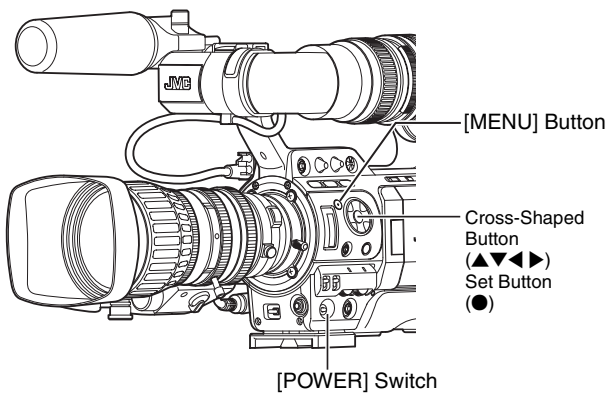

#### 1 Set the [POWER] switch to "ON".

The [Initial Setting] screen appears.

#### ■ For GY-HM790CHU/GY-HM790U

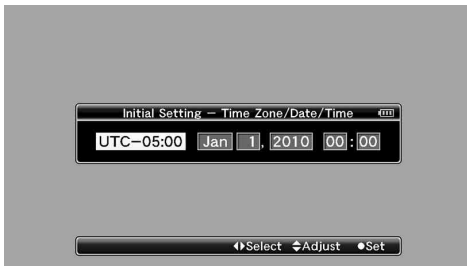

#### ■ For GY-HM790CHE/GY-HM790E

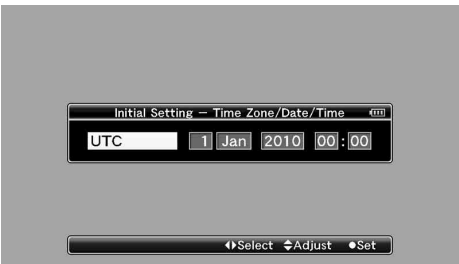

#### 2 Specify [Time Zone] and [Date/Time].

① Move the cursor with the cross-shaped button (◀▶) and select the setting item.

② Change the values with the cross-shaped button (▲▼).

#### 3 Press the Set button after setting is complete.

The clock is set to 0 seconds of the input date/time.

#### Memo :

- The configured date/time data can be displayed on the LCD monitor and viewfinder and be recorded to the SDHC card.
- The value of the year can be set in the range of "2000" to "2099".

### Changing the Time after Initial Setting

#### ■ Setting the date/time (☞ Page 95)

#### 1 Select [Others] menu → [Date/Time].

The [Date/Time] setting screen appears.

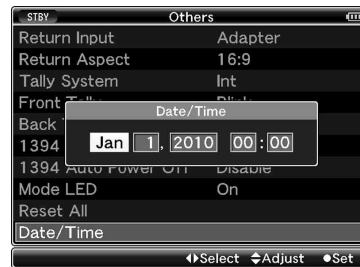

#### 2 Set the date and time.

① Move the cursor with the cross-shaped button (◀▶) and select the setting item.

② Change the values with the cross-shaped button (▲▼).

#### 3 Press the Set button (●) after setting is complete.

The clock is set to 0 seconds of the input date/time.

## Changing the Display Style

You can change the display style of the date/time on the menu.

### Memo :

- To perform the settings while looking at the monitor screen connected to the video signal output terminal, set [Analog Out Char.] or [SDI Out Char.] in the [A/V Out] menu to "On". (☞ Page 92)

### ■ Setting the date style (Date Style) (☞ Page 91)

- ① Select [LCD/VF] menu → [Status Display] menu → [Date Style].
- ② Select the date display style.  
[Setting values : YMD (year, month, day), MDY (month, day, year), DMY (day, month, year)]
- ③ Press the Set button (●).

### ■ Setting the time style (Time Style) (☞ Page 91)

- ① Select [LCD/VF] menu → [Status Display] menu → [Time Style].
- ② Select the time display style.  
[Setting values : 12hour (12 hour display), 24hour (24 hour display)]
- ③ Press the Set button (●).

## Date/Time Display in Different Operation Modes

During Camera mode	Date/time of the built-in clock is displayed.
During AUX mode (U model)	
During Media mode (SD Card mode)	Shooting date/time of the clip being played back is displayed.
During Media mode (IEEE1394 mode)	Date/time is not displayed.

## Adjusting the Monitor Speaker

The monitor speaker can be rotated 180 degrees. Adjust according to the position of your ear.

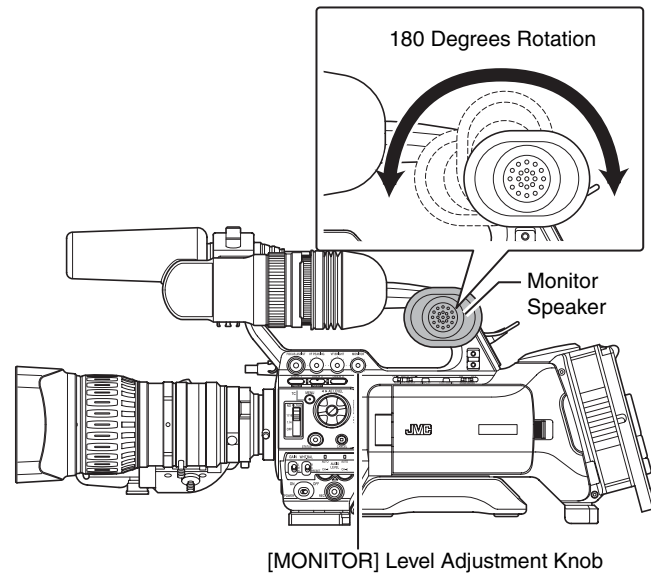

### Memo :

- Adjust the volume of the monitor speaker with the [MONITOR] level adjustment knob at the side control panel on the right of the camera recorder. Various warning alarm tones may also be output repeatedly. (☞ Page 135)

### Note :

- The rotation angle of the monitor speaker is 180 degrees. Do not over-rotate the monitor speaker.

## Adjusting Back Focus

When the lens is first attached, adjust the back focus of the lens if the focus is not clear when zoomed to the telephoto or wide angle end.

- Place an object 3 m and above away from the camera recorder.
- The Siemens Star Chart is most suitable as the object.

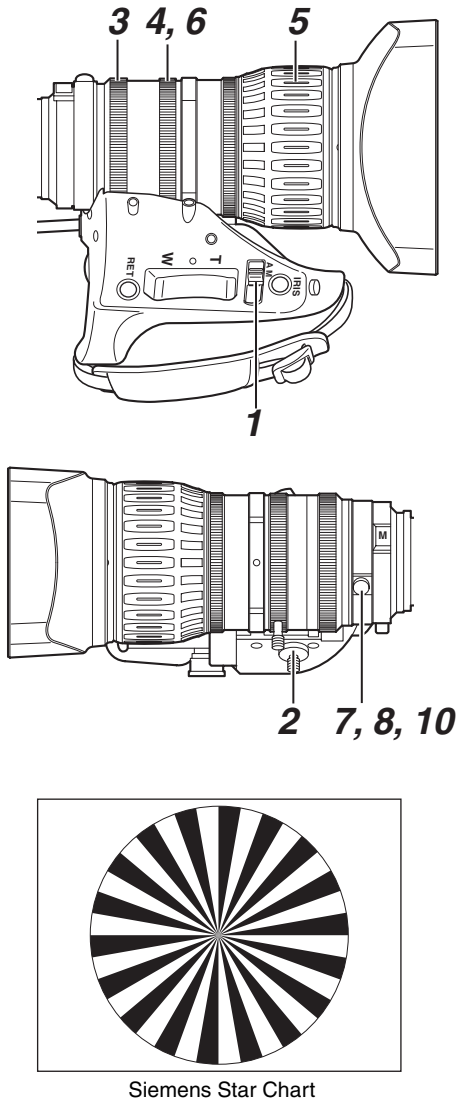

Siemens Star Chart

- 1** Set the iris mode switch of the lens to “M” (manual).
- 2** Set the zoom mode switch to “MANU.” (manual).
- 3** Turn to open the iris ring.  
Adjust the lighting such that the optimum image level can be obtained.
- 4** Turn the zoom lever to set the lens to the maximum telephoto position.

- 5** Turn the focus ring to adjust the focus of the object.
- 6** Set the lens to the maximum wide angle position.
- 7** Loosen the lock screw of the back focus ring.
- 8** Shoot the same object and secure the back focus ring at the position where the object is in focus.
- 9** Repeat steps 4 to 8 three times until the object is in focus at both the telephoto and wide angle positions.
- 10** Tighten and secure the lock screw of the back focus ring.

## Adjusting the LCD Monitor and Viewfinder

### Adjusting the LCD Monitor

You can change the angle and brightness of the LCD monitor screen according to your usage condition. Changing the brightness of the screen will not affect the recorded images.

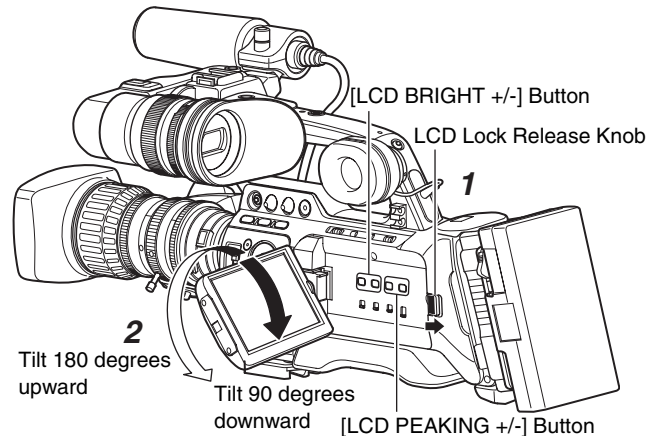

### Adjusting the Angle of the LCD Monitor

- 1** Slide the LCD lock release knob to open the LCD monitor.
- 2** Rotate the LCD monitor to adjust the angle.
  - While the LCD monitor is open, you can rotate it 180 degrees upward or 90 degrees downward.
  - Rotating the LCD monitor 180 degrees upward enables you to see the screen from the lens side. To display the image when it is viewed from the opposite direction (mirror image), perform setting as follows.  
[Main Menu] → [LCD/VF] menu → Set [LCD Mirror Mode] to “Mirror” → Press Set button (●) (Page 88)

## ■ Adjusting the LCD Monitor Screen

### Adjusting contour and brightness

- Use the [LCD BRIGHT +/-] button to adjust the brightness of the LCD monitor screen. Press the [+] and [-] buttons simultaneously to return to standard settings.

[+] : Press this button to brighten the screen.  
 [-] : Press this button to darken the screen.

- During adjustment, the brightness level is displayed on the LCD monitor screen.
  - During Camera mode, SD Card mode (playback), or IEEE1394 mode



- During SD Card mode (thumbnail), menu operation, or USB mode



- Use the [LCD PEAKING +/-] button to adjust the contour of the LCD monitor screen. Press the [+] and [-] buttons simultaneously to return to standard settings.

[+] : Press the button to increase contour correction.  
 [-] : Press the button to decrease contour correction.

- During adjustment, the contour level is displayed on the LCD monitor screen.

(☞ Page 29 [Adjusting contour and brightness])

- During Camera mode, SD Card mode (playback), or IEEE1394 mode



- During SD Card mode (thumbnail), menu operation, or USB mode



## Adjusting the Viewfinder

You can change the brightness and peaking of the viewfinder screen according to your usage conditions.

Changing the brightness of the screen will not affect the recorded images.

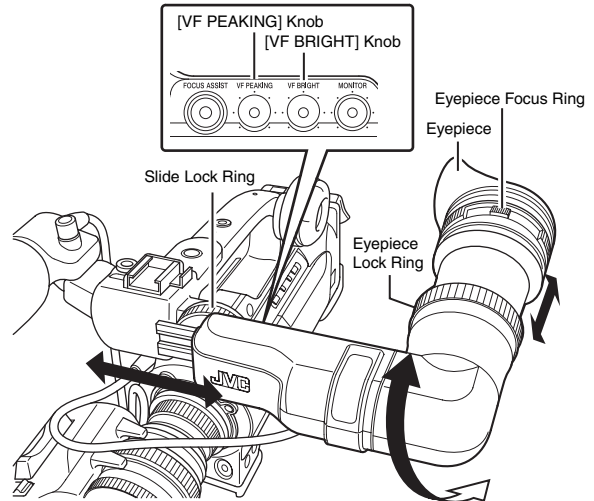

### Note :

- A high-definition viewfinder is used on this camera recorder in order to provide an accurate focusing environment. Due to the characteristic of the display device, colors may appear on the images when you blink your eyes. This is not a malfunction. It does not affect the recorded images, SDI output, or component output.

## ■ Adjusting the Angle

Adjust the position and angle of the viewfinder.

## ■ Adjusting the Visibility

Turn the eyepiece focus ring to sharpen the image on the viewfinder screen.

## ■ Adjusting the Viewfinder Screen

### Adjusting contour and brightness

- Use the [VF BRIGHT] knob to adjust the brightness of the viewfinder screen.
- Use the [VF PEAKING] knob to adjust the contour of the viewfinder screen.

※ Screen display during adjustment

(☞ Page 29 [Adjusting contour and brightness])

### Displaying in black and white (☞ Page 88)

You can display the viewfinder screen in black and white.

[Main Menu] → [LCD/VF] menu → [VF Display] item → Press Set button (●) → Select "B & W" → Press Set button (●)

## Preparations

### Adjusting the LCD Monitor and Viewfinder (continued)

#### Displays on the LCD Monitor and Viewfinder Screens

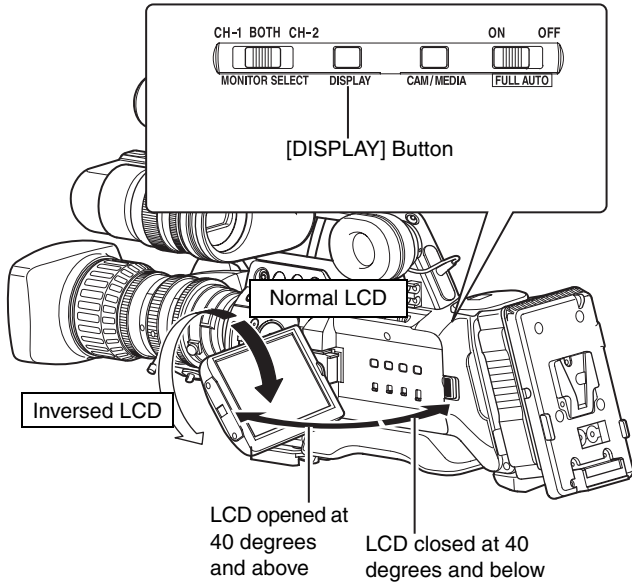

#### ■ When [LCD + VF] in the [LCD/VF] Menu is Set to “On” (☞ Page 88)

Displays on the LCD monitor and viewfinder screens (VF) are indicated as below.

LCD Monitor Status	LCD Display	VF Display
Closed LCD	Normal LCD	OFF
	Inversed LCD	ON
Opened LCD	Normal LCD	ON
	Inversed LCD	ON

#### Memo :

- Press and hold the [DISPLAY] button for 2 seconds to turn ON/OFF the LCD monitor screen.
- The function to turn ON/OFF the LCD monitor screen by pressing the [DISPLAY] button can be canceled by opening/closing or rotating the LCD monitor.
- The viewfinder screen is always displayed.

### Tally Lamps

These are indicator lamps for recording and warning. The operation changes according to the menu settings. When the battery or remaining space on the SDHC card is low, the lamps blink. (Camera mode only)

Set using [Tally System]/[Front Tally]/[Back Tally] in the [Main Menu] → [Others] menu. (☞ Page 94)

#### ■ When [LCD + VF] in the [LCD/VF] Menu is Set to “Off” (☞ Page 88)

Displays on the LCD monitor and viewfinder screens (VF) are indicated as below.

LCD Monitor Status	LCD Display	VF Display
Closed LCD	Normal LCD	OFF
	Inversed LCD	OFF
Opened LCD	Normal LCD	OFF
	Inversed LCD	OFF

#### Memo :

- Press and hold the [DISPLAY] button for 2 seconds to switch the display between the LCD monitor and viewfinder screens.
- The function to switch between LCD monitor and viewfinder displays by pressing the [DISPLAY] button can be canceled by opening/closing or rotating the LCD monitor.
- When the LCD monitor is stored in the camera recorder in the direction of normal display, pressing of the [DISPLAY] button will not work.
- You can display both the LCD monitor and viewfinder screens at the same time by selecting [LCD + VF] in the [LCD/VF] menu. (☞ Page 88)

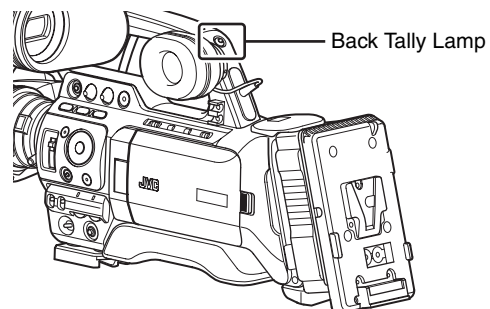
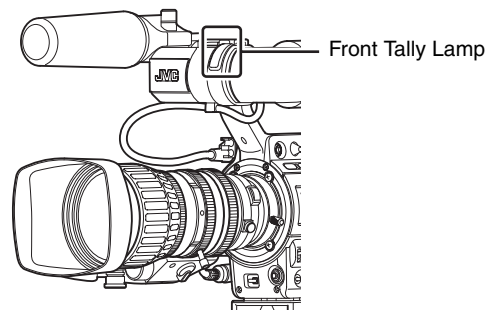



Menu Setting	[Tally System]	[Int]			[Ext]		[Studio]	
	[Front Tally]/ [Back Tally] *1	Off	On	Blink	On	Blink	On	Blink
Camera Recorder Information	Warning	—	—	▲	—	▲	—	▲
	Alarm	—	—	■	—	■*2	—	■
External Device Information	Warning	—	—	—	—	▲	—	—
	Alarm	—	—	—	—	—	—	—
Camera Recorder Recording Status	Recording	—	●	●	—	—	—	—
	Special Recording *3	—	●	●	—	—	—	—
External Device Recording Status	Recording	—	—	—	●	●	—	—
Remote Control Unit Input	[CALL]	—	—	—	—	—	■	■
	[TALLY(PGM)]	—	—	—	—	—	●	●
	[TALLY(PVW)]	—	—	—	—	—	○	○

- : Lights up
- ▲ : Blinks four times in 1 second
- : Blinks once in 1 second
- : Only back tally lamp lights up

- \*1 : [Front Tally] and [Back Tally] can be set independently with the menu settings. (☞ Page 94)
- \*2 : Only battery alarm is displayed.
- \*3 : Paused state during special recording ([Clip Continuous]). (☞ Page 59)

**Memo :**

- Blinking takes priority over lighting up.

## SDHC Cards

This camera recorder saves the recorded images and audio sound on the SDHC card (sold separately) in the card slot.

**Memo :**

- If the SDHC card contains files recorded by devices other than this camera recorder or files that are saved from a PC, the recordable time may be shorter or data may not be properly recorded.

### SDHC Cards to Use

Use a Class 6/10 SDHC card (4 GB - 32 GB).

**Note :**

- Using cards other than those from Panasonic, TOSHIBA or SanDisk may result in recording failure or data loss.

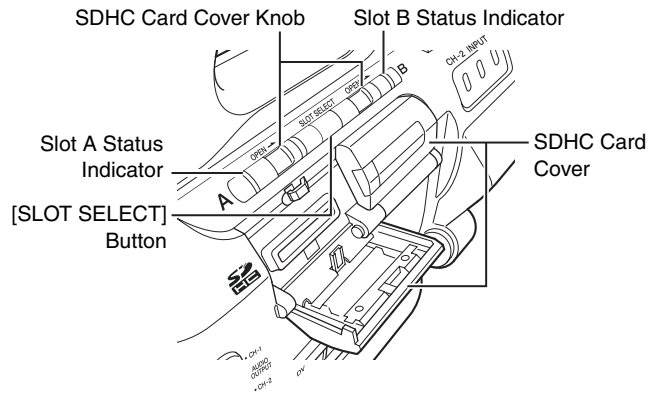

### Estimated Recordable Time of SDHC Cards

The estimated recordable time is only a guide. Differences may occur depending on the SDHC card in use and the battery condition.

(☞ Page 75 [Camera Resolution])

(☞ Page 75 [Frame & Bit Rate])

Camera Resolution	Bit Rate	SDHC Card Size			
		4 GB	8 GB	16 GB	32 GB
1280x720	HQ	12 min	25 min	50 min	100 min
1440x1080		17 min	35 min	70 min	140 min
1920x1080		22 min	45 min	90 min	180 min
1440x1080	SP	17 min	35 min	70 min	140 min
1280x720	SP	22 min	45 min	90 min	180 min
720 x 480	---	15 min	30 min	60 min	120 min
720 x 576	---	15 min	30 min	60 min	120 min

**Memo :**

- If the SDHC card contains files recorded by devices other than this camera recorder or files that are saved from a PC, the recordable time may be shorter or data may not be properly recorded.

### Write-Protect Switch on the SDHC Card

- ① Slide the write-protect switch upward to enable writing or deleting.
- ② Slide the write-protect switch downward to prevent writing or deleting. (Images in the card are protected.)

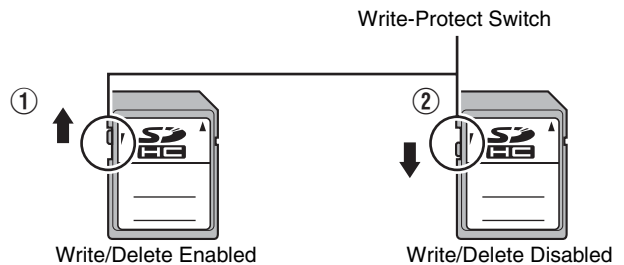

## SDHC Cards (continued)

### Inserting an SDHC Card

This camera recorder comes with two card slots for video/audio recording and playback (Slot A and B).

- 1** Slide the SDHC card cover knob of the desired slot in the direction of the arrow and open the cover.
- 2** Insert an SDHC card with the notched corner first.
- 3** Close the SDHC card cover.

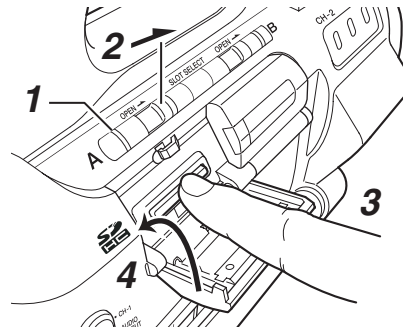
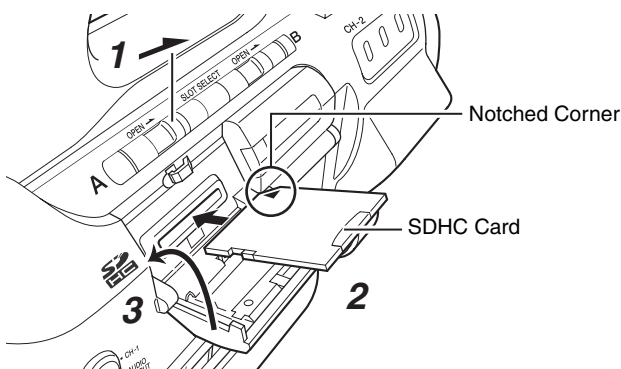

**Memo :**

- When both slots are inserted with usable SDHC cards, the previously selected slot is used.

**Note :**

- Data may be lost if you turn off the power of the camera recorder or remove the SDHC card when it is being accessed. All data recorded on the card, including the file that is being accessed, may be corrupted. Be sure to check whether the status indicator is lighted in green or not before you turn off the power or remove the SDHC card.
- If you mistakenly remove the card when it is being accessed, reinsert the card only after the status indicator goes off.
- The SDHC card may not be recognized if you insert and remove the card within a short time. When this happens, remove the card and wait for a few seconds before you reinsert.

### Card Slot Status Indicator

The following table shows the respective states of slot A and B.

Lamp	Slot Status
Lights up in red	Inserted SDHC card is being accessed. (writing/reading data) Do not turn off the power of the camera recorder or remove the SDHC card.
Lights up in green	On standby. Inserted SDHC card can be used for recording or playback.
Light goes out	<ul style="list-style-type: none"> <li>• SDHC card is not inserted.</li> <li>• An unusable card is inserted.</li> <li>• An SDHC card is inserted but a different slot is selected.</li> </ul>

### Removing the SDHC Card

- 1** Check that the SDHC card to be removed is not being accessed (lights up in red).
- 2** Slide the SDHC card cover knob in the direction of the arrow and open the cover.
- 3** Push the SDHC card and remove it from the slot.
- 4** Close the SDHC card cover.

### Switching SDHC cards

When both card slots are inserted with SDHC cards, you can use the [SLOT SELECT] button to switch the card to use. When the memory on an SDHC card is full during recording, data recording automatically switches to the other card.

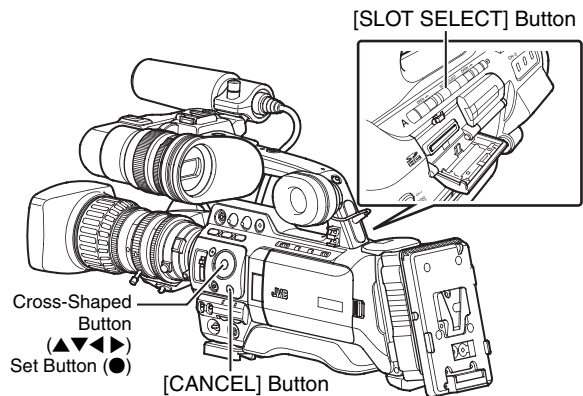

**Note :**

- The [SLOT SELECT] button is disabled during recording or playback. Cards will not be switched even if you press the button.



## Formatting (Initializing) SDHC Cards

When the following cards are inserted, "FORMATTING REQUIRED" appears. Format the card using the camera recorder menu.

- Unformatted SDHC cards
- SDHC cards formatted under different specifications

\* For details of the menu operation, see [Basic Operations in Menu Screen] (Page 70).

### Note :

- Be sure to format the SDHC card on this camera recorder. SDHC cards formatted on a PC and other peripheral equipment cannot be used on this camera recorder.

### Memo :

- To cancel the message display, press the [CANCEL] button. A [!] mark appears at the remaining media display area when an SDHC card that requires formatting is inserted.

**1** Select [Format Media] in the [Media] menu.  
(Page 97)

**2** Select the slot of the SDHC card to be formatted and press the Set button (●).

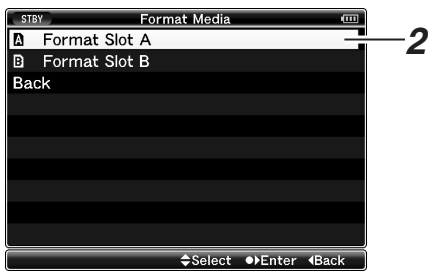

**3** The status of the selected SDHC card appears.

**4** Select [Format] and press the Set button (●).

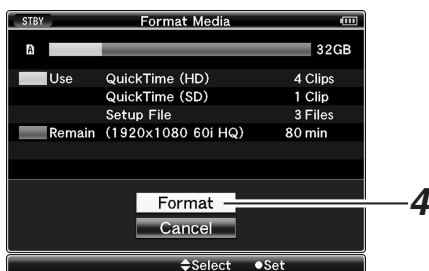

**5** Formatting starts.



**6** Formatting is complete.

"Complete" appears when formatting is complete.

### Memo :

- If you do not want to format the card, select [Cancel] or press the [CANCEL] button to return to the previous screen.
- If you remove the SDHC card during formatting, "Format Error!" appears and the camera recorder returns to the previous screen.
- During formatting, menu operation is unavailable but you can start recording. However, this is only available when a recordable SDHC card is inserted in the other slot.
- Formatting cannot be performed in the following cases.
  - Recording is in progress on the SDHC card to be formatted.
  - SDHC card is not inserted.
  - Write-protect switch of the SDHC card is set ( is displayed).

### Note :

- If you format the SDHC card, all data recorded on the card, including video data and setup files, will be deleted.

## SDHC Cards (continued)

### Restoring the SDHC Card

It is necessary to restore the SDHC card if an abnormality occurs to the data in the card due to some reasons. The message "RESTORE MEDIA" appears on the LCD monitor/viewfinder screen when an SDHC card that requires restoring is inserted.

**Memo :** \_\_\_\_\_

- To cancel the message display, press the [CANCEL] button. A [!] mark appears at the remaining media display area when an SDHC card that requires formatting is inserted.

- 1 Select [Restore Media] in the [Media] menu. (Page 97)
- 2 Select the SDHC card to be restored and press the Set button (●).



### 3 Restoring starts.



### 4 Restoring is complete.

- When restoring is complete, "Complete" appears and the camera recorder returns to the [Restore Media] screen.
- When no media that requires restoring is inserted, the camera recorder returns to the [Media] menu screen.



**Note :** \_\_\_\_\_

- [Restore Media] can only be selected in Camera mode. However, it cannot be selected while the camera recorder is recording. Select [Restore Media] in Camera mode when the camera recorder is not recording.
- [Restore Media] does not restore the SDHC card to its original states completely. If restoring fails, replace or format the SDHC card. Take note that formatting the SDHC card erases all information inside.

**Memo :** \_\_\_\_\_

- Restoring cannot be performed in the following cases.
  - Camera recorder is recording in progress.
  - SDHC card is not inserted.
  - Write-protect switch of the SDHC card is set (🔒 is displayed).
  - Restoring is not required.

---

## Clips Recorded to SDHC Cards

### ■ Folders in the SDHC Card

Images captured are recorded to [PRIVATE] → [JVC] folder inside the SDHC card.

Images recorded are sorted into the respective folders according to the menu settings below.

[System Definition] Setting	[File Format] Setting	Folders in the SDHC Card
HD (MPEG2)	MOV	CQAV
HD (MPEG2)	MP4	BPAV
SD (DV)	MOV	CQDV
SD (DV)	AVI	CADV

#### Memo :

- By formatting (initializing) the SDHC card from the [Format Media] menu on the camera recorder, folders required for recording in the current [System Definition] settings and [File Format] settings will be generated.
- When the [System Definition] settings and [File Format] settings are changed, folders required for recording in those settings will be automatically generated.

#### Note :

- When a clip inside the folder is moved or deleted using the Explorer (Windows) or Finder (Mac), recording to the SDHC card may fail if formatting (initializing) of the card is not performed.
- 

## ■ Recorded Clips

This camera recorder uses FAT32 File System.

As such, recorded materials may be split into several files due to the file size. However, they can be played back continuously on the camera recorder. Clips may be recorded across the two SDHC cards in card slots A and B depending on the recording time of the clip.

When copying clips to a HDD using a PC, it is recommended to use [JVC Clip Manager Software], which is found in the bundled CD-ROM, to maintain continuity.

#### Note :

- A clip recorded across several cards cannot be played back continuously. Continuous playback is only possible when the recording is made on one card.
- 

---

## Recording Clips

### ■ Clip (Recorded Data) and Clip Name

When recording is stopped, the images, audio and accompanying data which are recorded from start to stop are recorded as one "clip" on the SDHC card.

An 8-character clip name is automatically generated for the recorded clip. (Clip Name Prefix + Clip Number)

Example:

ABCG0001

#### Clip Number

A number in automatic ascending order is assigned in the recording order.

The clip number can be reset in the menu.

\* [Clip Set] → [Reset Clip Number] (☞ Page 76)

#### Clip Name Prefix (any 4 alphanumeric characters)

This is set to "xxxG" ("xxx" denotes the last 3 digits of the serial number) by default.

#### Memo :

- Before recording starts, you can set any characters for the clip name prefix by using [Main Menu] → [Record Set] menu → [Clip Set] → [Clip Name Prefix]. (☞ Page 76)
  - Changes cannot be made after recording.
-

# Basic Shooting Procedures

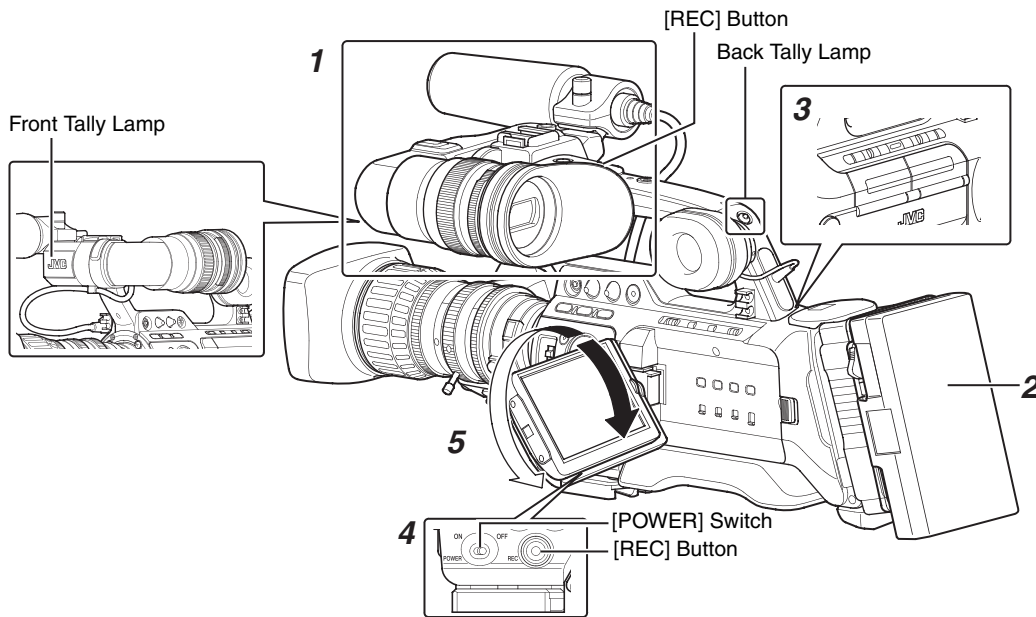

## Preparations

- 1 Attach the accessories.** (☞ Page 21)
- 2 Supply battery or AC adapter power to the camera recorder.** (☞ Page 22)
- 3 Insert an SDHC card.** (☞ Page 31)
- 4 Turn on the power of the camera recorder.**  
Set the [POWER] switch to “ON”. The camera recorder starts up in Camera mode and is ready for shooting.
- 5 Adjust the angle of the LCD monitor and viewfinder.** (☞ Page 28)

## Shooting

- 1 Configure the video and audio input settings.**  
You have to configure video settings such as brightness adjustment (iris, gain, shutter) and white balance adjustment in order to start shooting. You also have to adjust the audio input settings and audio recording level for audio recording.
  - Adjusting the Iris (☞ Page 39)
  - Setting Gain (☞ Page 40)
  - Setting the Electronic Shutter (☞ Page 40)
  - Adjusting the White Balance (☞ Page 42)
  - Adjusting the White Shading (☞ Page 44)
  - Setting the ND Filter (☞ Page 45)
  - Adjusting Audio Input Settings and Recording Level (☞ Page 46)

## 2 Press the [REC] button to start recording to the SDHC card.

- There are two [REC] buttons on the camera recorder and one on the lens. Any of the [REC] buttons can be used to start/stop recording by default.
- During recording, the front and back tally lamps light up in red.

### Memo :

- Tally lamps can be turned off with [Front Tally]/[Back Tally] in the [Others] menu. (☞ Page 94)
- To separately control this camera recorder and other equipment connected to the [IEEE1394] terminal, you can configure the setting at [1394 Rec Trigger] in the [Others] menu. (☞ Page 94)

## 3 Check the most recently captured images (Clip Review).

Press the [RET] button on the lens to activate the Clip Review function (☞ Page 56). The most recently captured images are played back on the LCD monitor and viewfinder screens. After playback, the camera recorder returns to standby mode (STBY).

\* When [Main Menu] → [Camera Function] → [Switch Set] → [LENS RET] is set to “Clip Review” (☞ Page 79)

---

## Focus Assist Function

When the [FOCUS ASSIST] button is pressed during shooting, the focused area is displayed in color (blue, red, or green). This enables easy and accurate focusing. Select the color in the menu.

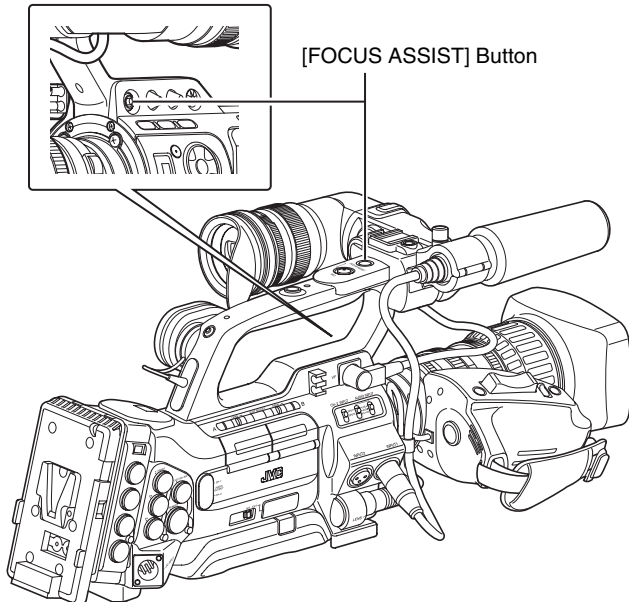

---

### Memo :

- When [Main Menu] → [LCD/VF] menu → [Shooting Assist] → [Focus Assist] is set to "ACCU-Focus", the depth of field becomes shallower to enable easier focusing. (☞ Page 89)
  - The "ACCU-Focus" function switches automatically to "Off" after about 10 seconds.
  - Select the display color in [Main Menu] → [LCD/VF] → [Shooting Assist] → [Color]. (☞ Page 89)
  - The [VF PEAKING] knob and [LCD PEAKING +/-] button do not function when Focus Assist is activated.
- 

### ■ Assigning Focus Assist function to the [RET] button on the lens

You can assign the Focus Assist function to the [RET] button on the lens.

- \* Set [Main Menu] → [Camera Function] → [Switch Set] → [LENS RET] to "Focus Assist". (☞ Page 79)

## Selecting System Definition, File Format and Video Format

You can select the system definition (HD or SD), file format for recording/playback and the record format for video images on this camera recorder.

- Memo :** \_\_\_\_\_
- Make a selection in [Main Menu] → [Record Format] menu.

### Selecting a System Definition

Select the system definition in [System Definition]. There are two different definitions for selection.  
 HD (MPEG2) : Records in HD (High Definition) quality  
 SD (DV) : Records in SD (Standard Definition) quality

### Selecting a File Format

Select a file format in [File Format]. There are three file formats for selection.  
 QuickTime : QuickTime file format (.MOV)  
 MP4 : MP4 file format  
 AVI : Standard video file format for Windows systems

- Memo :** \_\_\_\_\_
- The available options vary as follows depending on the [System Definition] setting.
    - “HD (MPEG2)” : QuickTime, MP4
    - “SD (DV)” : QuickTime, AVI

### Selecting a Video Format

Select a [Record Format] from the list of formats. The selectable [Frame & Bit Rate] changes according to the settings of [System Definition], [File Format], and [Camera Resolution].  
 The recording bit rate is 35 Mbps VBR when “HQ” is selected, and 18.3 Mbps (1080i is 25 Mbps) CBR when “SP” is selected.

### List of Formats

The following is a list of file formats and video formats that can be selected on this camera recorder.

- When [System Definition] is set to “HD (MPEG2)”

Record Format			Remarks
File Format	Camera Resolution	Frame & Bit Rate	
	Horizontal×Line		
QuickTime	1280x720	60p (HQ)	
		60p (SP)	HDV compatible
		30p (HQ)	
		30p (SP)	HDV compatible
		24p (HQ)	
		24p (SP)	HDV compatible
		50p (HQ)	
		50p (SP)	HDV compatible
		25p (HQ)	
	25p (SP)	HDV compatible	
	1440x1080	60i (HQ)	
		60i (SP)	HDV compatible
		50i (HQ)	
		50i (SP)	HDV compatible
	1920x1080	60i (HQ)	Full HD
		30p (HQ)	Full HD
		50i (HQ)	Full HD
		25p (HQ)	Full HD
24p (HQ)		Full HD	
MP4	1280x720	60p (HQ)	
		60p (SP)	HDV compatible
		30p (HQ)	
		30p (SP)	HDV compatible
		24p (HQ)	
		24p (SP)	HDV compatible
		50p (HQ)	
		50p (SP)	HDV compatible
		25p (HQ)	
	25p (SP)	HDV compatible	
	1440x1080	60i (SP)	HDV compatible
		50i (SP)	HDV compatible
	1920x1080	60i (HQ)	Full HD
		30p (HQ)	Full HD
		50i (HQ)	Full HD
		25p (HQ)	Full HD
		24p (HQ)	Full HD

■ When [System Definition] is set to “SD (DV)”  
 When [System Definition] is set to “SD (DV)”, the video format is fixed as follows for the different models.

Record Format			Remarks
File Format	Camera Resolution Horizontal×Line	Frame & Bit Rate	
QuickTime/ AVI	720 x 480(U model)	60i	DV compatible
	720 x 576(E model)	50i	DV compatible

## Selecting the Aspect Ratio of SD Videos

Select an aspect ratio for the images.  
 The available options vary as follows depending on the [System Definition] setting.

- “HD (MPEG2)” : Fixed at 16:9
- “SD (DV)” : 16:9, 4:3

## Setting the Record Format Menu

- 1 Display the [Main Menu] → [Record Format] menu.
  - 2 Set each of the items.
  - 3 After setting is complete for all items, select [SET] at the bottom of the screen, and press the Set button (●).
- The record format is switched.
  - A “Please Wait” message appears on the screen during switching.

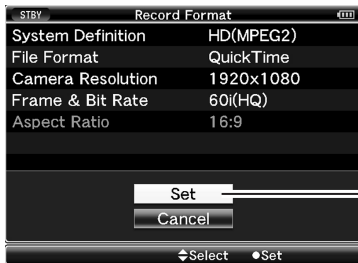

**Note :** \_\_\_\_\_  
 • [System Definition] is fixed at “SD (DV)” in the AUX mode. Only [File Format] and [Aspect Ratio] can be set. (U model)

## Adjusting the Iris

You can adjust the aperture of the lens iris manually or automatically according to the brightness of the object.

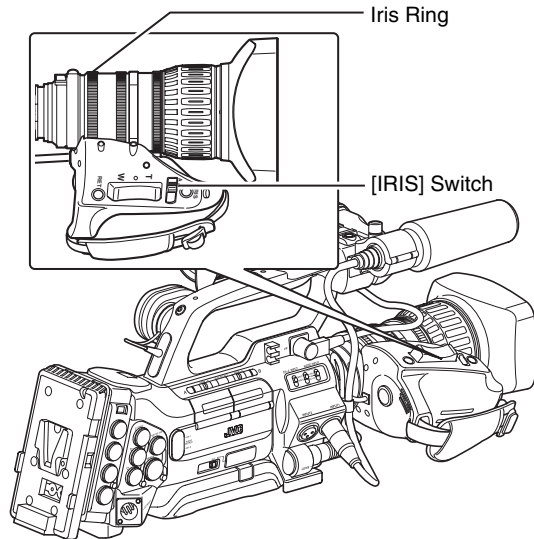

### Manual Iris (Manual Adjustment) Mode

Set the [IRIS] switch on the lens to “M” to enter Manual Iris mode.

Turn the iris ring on the lens to adjust the iris manually.

**Memo :** \_\_\_\_\_  
 • Even during Manual Iris mode, the camera recorder enters forced Auto Iris mode while the [IRIS AUTO] button is pressed.

### Auto Iris (Automatic Adjustment) Mode

Set the [IRIS] switch on the lens to “A” to enter Auto Iris mode. The iris is automatically adjusted according to the brightness of the object.

**Memo :** \_\_\_\_\_  
 • Even when the [IRIS] switch of the lens is set to “M”, it switches automatically to Auto Iris mode when the [FULL AUTO] switch is set to “ON”.  
 • When [Iris Control] in the [Camera Function] → [FULL AUTO] menu is set to “Off”, you can adjust the iris manually even if the [FULL AUTO] switch on the camera recorder is set to “ON”. (Page 81)  
 • You can use the cross-shaped button (◀▶) on this camera recorder to set the target level (brighter/darker) of the auto iris. You can also use the menu to set the tracking sensitivity of the auto iris. (Page 78)

## Setting Gain

This function electrically boosts the light sensitivity when there is insufficient illumination on the object. You can set the gain of the video amplifier according to the brightness of the object. Select the setting mode according to your shooting conditions.

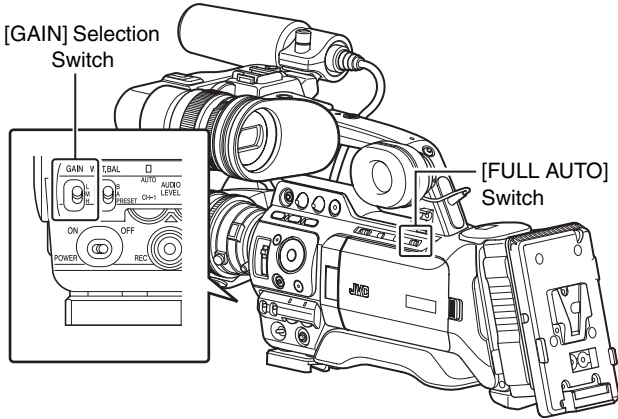

### Fixed Gain Mode (Manual Gain Switching)

You can select the gain of the video amplifier using the [GAIN] switch on the camera recorder. The default positions of the switch are as follows.

- [L] : 0 dB (No electrical boosting.)
- [M] : 9 dB (Boosts sensitivity by about 2.8 times.)
- [H] : 18 dB (Boosts sensitivity by about 8 times.)

**Memo :**

- The gain value of each position can be set to “ALC” and within the range of “0dB” to “18dB” (in increments of 3 dB) in the menu. Increasing the sensitivity causes the screen to appear grainier. (☞ Page 79)

### Automatic Gain Mode (Automatic Gain Adjustment)

Set the [FULL AUTO] switch on the camera recorder to “ON” to enter Automatic gain Level Control (“ALC” fixed). The gain of the video amplifier is automatically set according to the brightness of the object. In this case, the [GAIN] switch on the camera recorder is disabled.

**Memo :**

- When [Gain] in the [Camera Function] → [FULL AUTO] menu is set to “SW Set”, you can switch the gain with the [GAIN] switch even if the [FULL AUTO] switch on the camera recorder is set to “ON”. (☞ Page 81)

## Setting the Electronic Shutter

You can change the shutter speed (time for each shooting frame) using the electronic shutter function. Electronic shutter can be adjusted manually or automatically.

### Fixed Shutter Mode (Manual Shutter Switching)

Use the Set button (●) to switch between the shutter modes and the cross-shaped button (▲▼) to switch between the speeds.

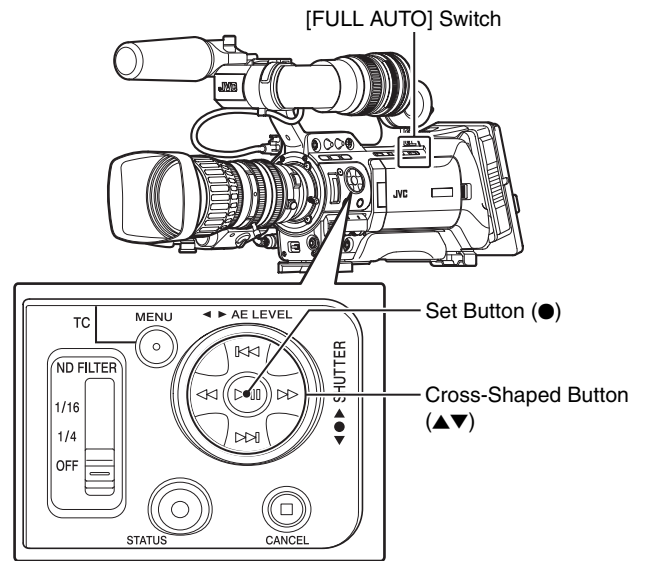

### Switching Shutter Mode

Press the Set button (center of the cross-shaped button) to turn ON/OFF the shutter.

**Memo :**

- When the shutter is ON, “Step”, “Variable”, or “EEI” (Extended Electric Iris, i.e. Automatic Shutter mode) may be selected using [Shutter] in the [Camera Function] menu. “Step” is the factory default. (☞ Page 78)



## Switching Shutter Speed

When shutter is ON, use the cross-shaped button (▲▼) to set the shutter speed. Shutter speed differs according to the video format and variable frame rate settings.

### During modes other than Variable Frame Rec

Shutter	Camera Resolution/ Frame & Bit Rate	720/25p			
		720/60p 720/30p 1080/60i 1080/30p 480/60i	720/50p 720/25p 1080/50i 1080/25p 576/50i	720/24p 1080/24p	
▲ Button	Step			1/10000	
			1/10000	1/4000	
			1/4000	1/2000	
			1/2000	1/1000	
			1/1000	1/500	
			1/500	1/250	
			1/250	1/100	
			1/100	1/60	
		(Standard)	1/60	1/50	1/48
			1/30	1/25	1/24
			1/15	1/12.5	1/12
		▼ Button		1/7.5	1/6
▲ Button	Variable	(Upper limit)	1/10489.5		
			~		
		(Standard)	1/60.00	1/50.00	1/48.00
			~		
▼ Button		(Lower limit)	1/30.03	1/25.04	1/24.01

### During Variable Frame Rec

Shutter	Camera Resolution/ Frame & Bit Rate	720/30p 720/24p				
		Frame Rate	60, 30, 15	48, 24, 12	40, 20, 10	
▲ Button	Step				1/10000	
				1/10000	1/4000	
			1/10000	1/4000	1/2000	
			1/4000	1/2000	1/1000	
			1/2000	1/1000	1/500	
			1/1000	1/500	1/250	
			1/500	1/250	1/100	
			1/250	1/100	1/60	
			1/100	1/60	1/48	
		(Standard)	1/60	1/48	1/40	
			1/30	1/24	1/20	
			1/15	1/12	1/10	
▼ Button		1/7.5	1/6	1/5		
▲ Button	Variable	(Upper limit)	1/10489.5			
			~			
		(Lower limit)	1/60.00	1/48.00	1/40.00	
			~			

Shutter	Camera Resolution/ Frame & Bit Rate	720/25p		
		Frame Rate	50, 25, 12.5	40, 20, 10
▲ Button	Step			1/10000
			1/10000	1/4000
			1/4000	1/2000
			1/2000	1/1000
			1/1000	1/500
			1/500	1/250
			1/250	1/120
			1/120	1/50
		(Standard)	1/50	1/40
			1/25	1/20
			1/12.5	1/10
		▼ Button		1/6.25
▲ Button	Variable	(Upper limit)	1/10489.5	
			~	
		(Lower limit)	1/50.00	1/40.00
			~	

### Memo :

- Shutter speed is usually displayed in seconds (SEC). However, only when [Frame & Bit Rate] is set to "24p (SP)", "24p (HQ)", "25p (SP)", or "25p (HQ)", the speed can be displayed in angle (DEG). (☞ Page 75 [Frame & Bit Rate]) (☞ Page 91 [Shutter Disp.] )

## Automatic Shutter Mode (Automatic Shutter Adjustment)

Set the [FULL AUTO] switch on the camera recorder to "ON" to enter the automatic shutter adjustment mode. The shutter speed is automatically adjusted according to the brightness of the object.

Switching of shutter speed with the cross-shaped button (▲▼) and switching of shutter mode with the Set button (●) are disabled.

### Memo :

- When [Shutter] in the [Camera Function] → [FULL AUTO] menu is set to "SW Set", you can switch the shutter mode with the Set button (●) and shutter speed with the cross-shaped button (▲▼) even if the [FULL AUTO] switch on the camera recorder is set to "ON". (☞ Page 81)
- When [Shutter] in the [Camera Function] → [FULL AUTO] menu is set to "EEI", the camera recorder enters Automatic Shutter Adjustment mode. Switching of shutter mode with the Set button (●) and shutter speed with cross-shaped button (▲▼) is disabled. (☞ Page 81)

## Adjusting the White Balance

Adjust the white balance according to the color temperature of the lighting. You can select the adjustment mode according to the shooting conditions.

As the color of the light (color temperature) varies according to the light source, it is necessary to readjust the white balance when the main light source illuminating the object changes.

[WHT.BAL.] Selection Switch

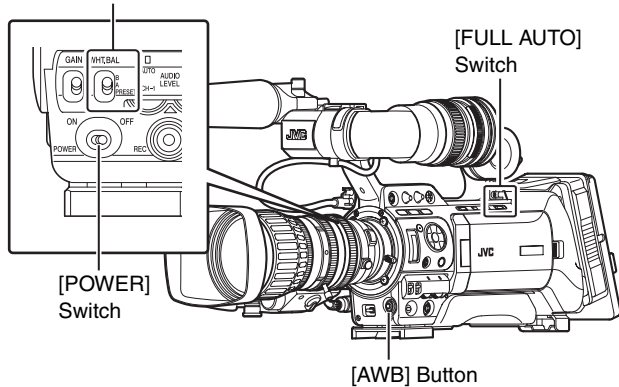

### Manual White Balance Mode (Manual Switching)

You can select the white balance with the [WHT.BAL.] selection switch.

Use the [WHT.BAL.] selection switch to select "PRESET" (preset mode), "A" (memory A mode), or "B" (memory B mode).

**Memo :** \_\_\_\_\_

- The [FAW] (Fulltime Auto White balance) function can be assigned to the [A], [B], or [PRESET] button using [Switch Set] in the [Camera Function] menu. (☞ Page 79)
- In [FAW] mode, color temperature of the images is sampled and white balance is automatically adjusted to the appropriate level.
- When [White Balance] in the [Camera Function] → [FULL AUTO] menu is set to "FAW" and the [FULL AUTO] switch on the camera recorder is set to "ON", the mode is fixed at "FAW".

### ■ Preset Mode (PRESET)

Two different color temperature settings are registered on this camera recorder. You can switch between them using the [AWB] button.

(Default setting: "3200K" ↔ "5600K")

You can change both the color temperature settings in the Preset mode in the menu.

[Main Menu] → [Camera Process] → [White Balance] menu → Select either [Preset Temp.] or [Alternative Temp.]. (☞ Page 85)

**1** Set the [W. BAL] switch to "PRESET".

**2** Press the [AWB] button.

Press the [AWB] button to switch to a different color temperature. ("Preset Temp." ↔ "Alternative Temp.")

### ■ Memory A Mode (A), Memory B Mode (B)

Set to the white balance saved in Memory A or Memory B. When the [WHT.BAL.] selection switch is set to [A] or [B], press the [AWB] button to execute white balance. The white balance will be automatically adjusted and the adjusted value will be saved in Memory A or Memory B.

**1** Prepare the camera recorder.

- ① Set the [POWER] switch to "ON".
- ② Set the iris mode switch of the lens to "A" (automatic).
- ③ Set the [FULL AUTO] switch to "OFF".

**2** Set the [ND FILTER] switch according to the lighting (☞ Page 45).

**3** Set the [WHT.BAL.] switch to "A" or "B".

**4** Locate a place with similar lighting conditions as the object to be shot, place a white object near the center of the screen and zoom in to fill the screen with white.

**5** Press the [AWB] (Auto White Balance) button.

- The white detection frame appears when Auto White Balance is activated. Fill the frame with white completely.
- "AUTO WHITE A, B OPERATION" appears on the viewfinder when Auto White Balance is activated.
- When the correct white balance is achieved, "AUTO WHITE A, B OK" appears for about 3 seconds together with the approximate color temperature.

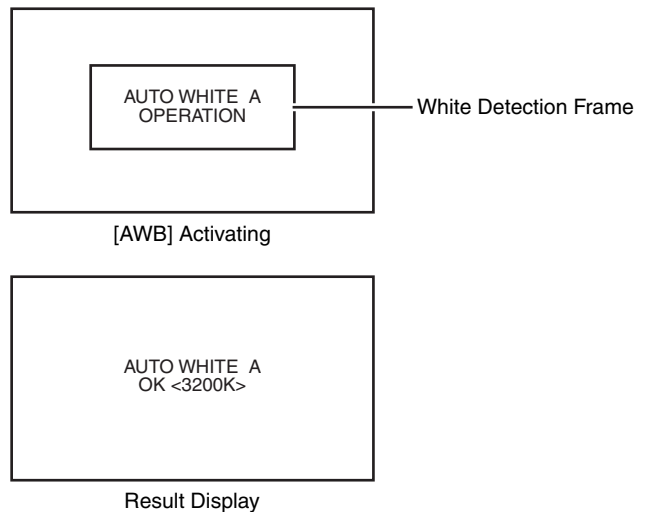

**Note :** \_\_\_\_\_

- Do not use highly reflective objects, such as metals. Doing so may result in improper white balance adjustment.
- The Auto White function cannot provide optimum white balance with an object outside the adjustment range, for example when it contains only a single color or not enough white color.

## ■ Error Message

If the white balance adjustment is not correctly completed, one of the following messages will appear for about 5 seconds.

Error Message	Status
NG : OBJECT	The object used is defective. Displayed when there is not enough white color on the object, or when the color temperature is not suitable. Use another white object and adjust the white balance again.
ERROR : LOW LIGHT	Insufficient illumination. Displayed when the lighting is dark. Increase the lighting and adjust the white balance again.
ERROR : OVER LIGHT	Excessive illumination. Displayed when the lighting is too bright. Decrease the lighting and adjust the white balance again.

## ■ White Paint Adjustment

You can fine-tune the white balance saved in Memory A or Memory B.

\* Adjust [White Paint R]/[White Paint B] in [Main Menu] → [Camera Process] → [White Balance] menu (☞ Page 85)

When [AWB] is selected, the normal white paint adjustment value is cleared. However, you can also set to keep the value even when [AWB] is executed. (☞ Page 85)

## Automatic White Balance Mode (FAW: Fulltime Auto White balance)

You can assign "FAW" (Fulltime Auto White balance) to any of the three positions on the [WHT.BAL.] selection switch. Configure the setting with [FAW] in the [Camera Function] → [SW Set] menu. (☞ Page 79)

Set the [FULL AUTO] switch on the camera recorder to "ON" to enter FAW mode. White balance is automatically adjusted according to the color temperature of the lighting on the object.

White balance switching with the [WHT.BAL.] selection switch is disabled.

### Memo :

- When [White Balance] in the [Camera Function] → [FULL AUTO] menu is set to "SW Set", you can switch the white balance with the [WHT.BAL.] selection switch on the camera recorder. (☞ Page 81)

### Note :

- The accuracy of [FAW] is inferior to that of Auto White Balance.
- When the power of the camera recorder is turned on with the [FAW] mode selected, it takes about 15 seconds for the colors to stabilize.

# Adjusting the White Shading

You need to adjust white shading when you change the lens. Even if white balance is adjusted in the center of the screen, the top and bottom of the screen may not be adjusted. In this case, green and yellow colors may appear on the screen. This is due to the characteristic of the lens. Correcting this phenomena is known as white shading adjustment.

Perform this adjustment after adjusting the white balance.

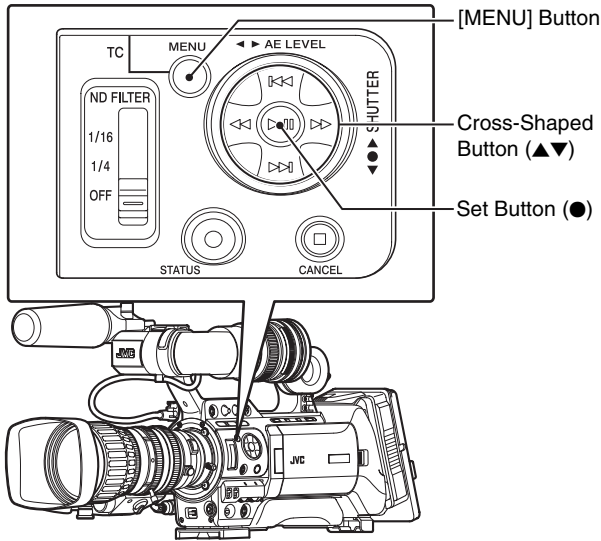

**1** Fill the monitor screen with a pattern box of uniform light source or white (plain) paper shone with uniform lighting.

**2** Set the control of the camera lens as follows.

- ① Set the aperture to F4 or more such that the iris achieves optimum brightness. If the brightness is insufficient even at F4, set to the optimum brightness by increasing the lighting.
- ② When using a zoom lens, set to the center of the zoom adjustment range.

**3** Adjust the white balance of the camera recorder. (☞ Page 42 [Memory A Mode (A), Memory B Mode (B)])

**4** Set the chroma level of the monitor to the maximum.

**5** Check the monitor screen.

- There is no need for adjustment if there is no color at the top and bottom of the screen.
- If the top of the screen is greenish and the bottom is reddish or vice versa, continue this adjustment.

**6** Adjust the white shading.

It is recommended to adjust only G (green).

- ① Set [Main Menu] → [Camera Process] → [White Balance] → [Shading Mode] to "Manual". (☞ Page 85)
- ② Select [Adjust] in the [White Balance] menu and press the Set button (●).

- ③ Select the item to change with the cross-shaped button (▲▼) and press the Set button (●).
- ④ Change the setting value with the cross-shaped button (▲▼) while looking at the evaluated value at the bottom right of the LCD monitor or viewfinder screen.
  - If the evaluated value of the adjusting channel is larger than 0, use the cross-shaped button (▼) to change the setting value so that the value is more or less "Even". Similarly, if the value is smaller than 0, use the cross-shaped button (▲) to change the setting value. (☞ Page 44 [Evaluated value:])

[R]	Red adjustment
[G]	Green adjustment
[B]	Blue adjustment

(Adjustment range : Min (-128) to Normal to Max (127))

**Memo :**

- There may be some delay in the changes of the evaluated value after pressing the cross-shaped button (▲▼).
- Increasing the setting value suppresses the colors at the bottom and enhances the colors on top.

- ⑤ Press the Set button (●) to save the settings after the changes are complete.
- ⑥ Select [Back] and press the Set button (●) to return to the [White Balance] menu.

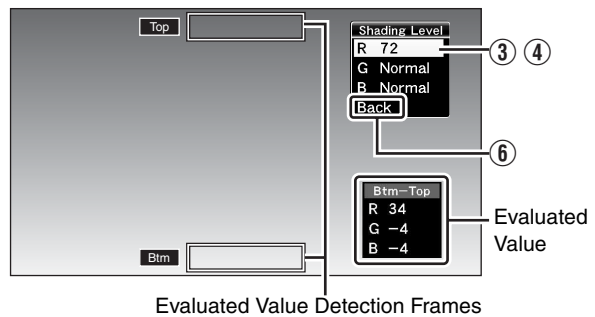

**7** Press the [MENU] button to return to the normal screen.

**8** Readjust the white balance. (☞ Page 42)

**Note :**

- If the lens setup is incorrect, you may over-correct the white shading. Set to the recommended settings for the lens. (Do not open the iris more than F4. Do not adjust the zoom lens at the telephoto or wide angle end.)
- White shading occurs as a result of the optical characteristic of the attached lens. This is not a camera malfunction.

**Evaluated value:**

A value that compares the average values of the R, G, B channels in the evaluated value detection frames at the top (Top) and bottom (Btm) of the LCD monitor or viewfinder (difference between [Top] and [Btm]). If [Top] is larger than [Btm], a negative value is displayed. If [Top] is smaller than [Btm], a positive value is displayed. When there is no difference between [Top] and [Btm], "Even" is displayed. Set such that the evaluated value is more or less "Even".

# Setting the ND Filter

Use the ND filter to keep the lens aperture in the appropriate range.

Switch according to the brightness of the object. When the switch is changed, the position of the switched ND filter is displayed on the LCD monitor and viewfinder screens. (STATUS 1 Screen)

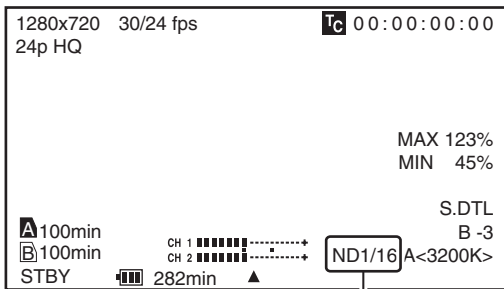
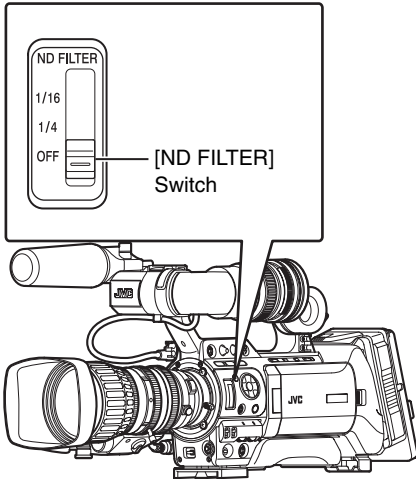

Displays the position of the ND filter

[1/16]	Reduces the amount of incident light to 1/16. Select this for extremely bright outdoor environments.
[1/4]	Reduces the amount of incident light to 1/4. Select this for bright and sunny outdoor environments.
[OFF]	Select this for indoor and dark outdoor environments.

**Memo :**

- The display of the ND filter position is set to “Off” by default. To display the position of the ND filter, set [Filter] in the [LCD/VF] → [Status Display] menu to “On”. (Page 90)
- It is recommended to use the ND filter to set the lens aperture to less than F5.6.

## Adjusting Audio Input Settings and Recording Level

You can record audio from the two channels (CH-1/CH-2) in synchronization with video images on this camera recorder. The camera recorder is equipped with [INPUT1] and [INPUT2] terminals for audio input. You can select a recording channel and the adjustment mode (manual/automatic).

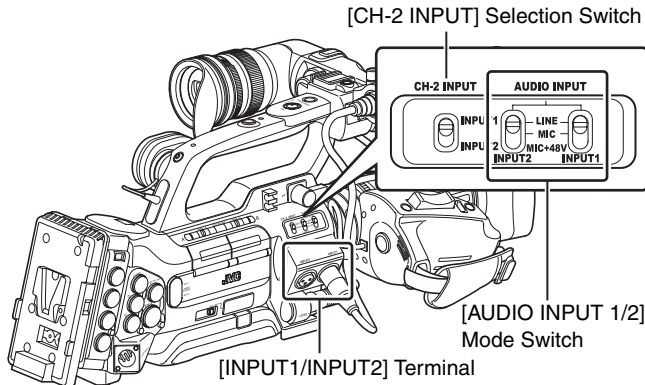

### Setting Audio Input

Select the audio to input through [INPUT1] and [INPUT2] terminals with the [AUDIO INPUT 1/2] mode switch.

[LINE]	Use this setting when connecting to an audio device or other equipment. The reference input level is +4 dBu.
[MIC]	Use this setting when connecting to a dynamic microphone.
[MIC+48V]	Use this setting when connecting to a microphone (phantom microphone) that requires a +48 V power supply.

**Note :**

- When connecting a device that does not require a +48 V power supply, make sure that it is not set to the “MIC+48V” position.
- When the [AUDIO INPUT 1/2] mode switch is set to “MIC”, make sure that a microphone is connected to the [INPUT1/INPUT2] terminal. If you increase the recording level when a microphone is not connected, noise from the input terminal may be recorded.
- When a microphone is not connected to the [INPUT1/INPUT2] terminal, set the [AUDIO INPUT 1/2] mode switch to “LINE” or adjust the volume with the [AUDIO LEVEL CH-1/CH-2] recording level adjustment knob.

**Memo :**

- Set the reference input level of “MIC” and “MIC+48V” using [Input1 Mic Ref.]/[Input2 Mic Ref.] in the [Main Menu] → [Record Set] → [Audio Set] menu. (☞ Page 77)

### Setting of [CH-2 INPUT] Selection Switch

Use the [CH-2 INPUT] selection switch to select the audio to be recorded to CH-2.

[INPUT1]	Records audio from [INPUT1] terminal to CH-2.
[INPUT2]	Records audio from [INPUT2] terminal to CH-2.

### Adjusting Audio Recording Level

You can select to adjust the audio recording levels for the two channels (CH-1/CH-2) manually or automatically.

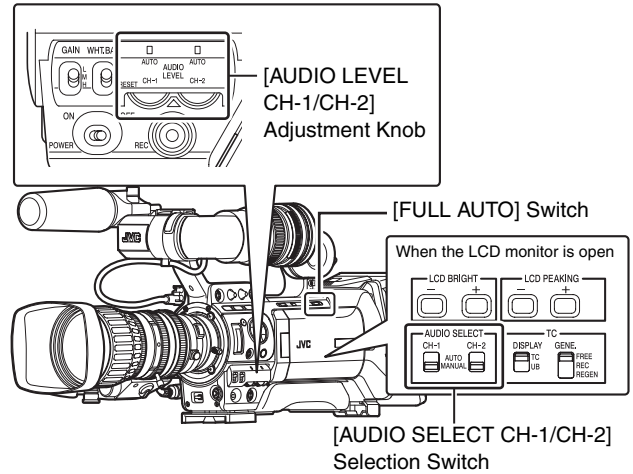

### Manual Adjustment Mode (Manual Adjustment)

Set the [AUDIO SELECT CH-1/CH-2] switch on the camera recorder to “MANUAL” to enter the manual adjustment mode, and use the [AUDIO LEVEL CH-1/CH-2] adjustment knob to set the recording level.

You can adjust the level manually during the recording, recording pause, and stop modes.

**1** Set the [AUDIO SELECT CH-1/CH-2] switch to “MANUAL” for the channel to manually adjust the recording level.

**2** Turn the corresponding [AUDIO LEVEL CH-1/CH-2] adjustment knob to adjust the level.

Adjust such that the audio level meter does not light up at -2 dB even for loud sounds.

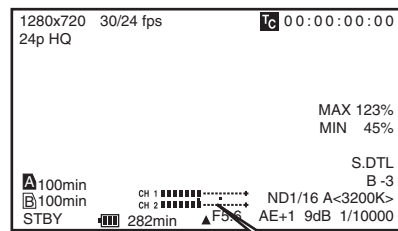

STATUS 1 Screen

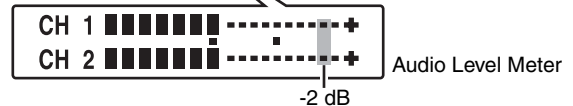

**Memo :**

- Set [Audio Limiter] in the [Main Menu] → [Record Set] → [Audio Set] menu to “On” to activate the audio limiter in the Manual Adjustment mode. This controls the recording level when excessive audio signals are input. (☞ Page 77)
- For the reference level to be recorded on SDHC cards, set [Audio Ref. Level] in the [Main Menu] → [Record Set] → [Audio Set] menu to “-20dB” or “-12dB”. (common for CH-1, CH-2) (☞ Page 77)

**Note :**

- When the [FULL AUTO] switch on the camera recorder is set to "ON", the recording level cannot be adjusted with the [AUDIO LEVEL CH-1/CH-2] adjustment knob.

## ■ Automatic Adjustment Mode

Set the [AUDIO SELECT CH-1/CH-2] switch on the camera recorder to "AUTO" or the [FULL AUTO] switch to "ON" to enter Automatic Adjustment mode. The audio recording level is set automatically according to the input level.

When the [FULL AUTO] switch is set to "ON", mode switching with the [AUDIO SELECT CH-1/CH-2] switch is disabled.

**Memo :**

- When [Audio] in the [Camera Function] → [FULL AUTO] menu is set to "SW Set", you can switch the recording level mode with the [AUDIO SELECT CH-1/CH-2] switch on the camera recorder even if the [FULL AUTO] switch is set to "ON". (Page 81)

## Audio Monitor During Recording

You can check the input audio with the monitor speaker or earphones.

**1** Select the channel to monitor with the [MONITOR SELECT] switch.

[CH-1]	Outputs audio from [INPUT1] terminal.
[BOTH]	Mixes and outputs audio from both [INPUT1/INPUT2] terminals.
[CH-2]	Outputs audio from [INPUT2] terminal.

**2** Adjust the volume of the monitor audio with the [MONITOR] adjustment knob.

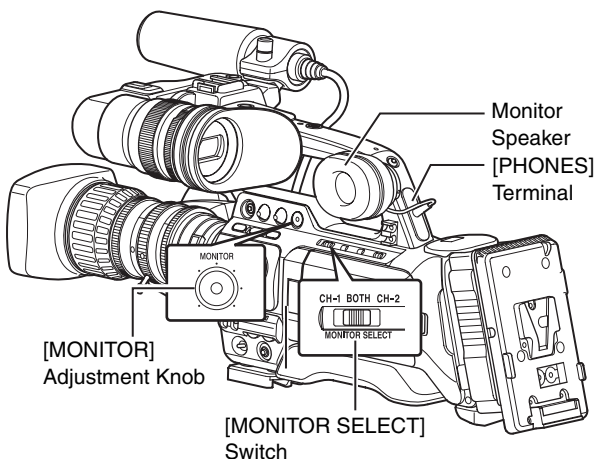

**Memo :**

- Alarm tone is output when there is an abnormality in the camera recorder. Alarm tone is also output when the SDHC card is full or when the battery is low. (Page 135)
- Alarm tone is not output during recording.

**Note :**

- Increasing the volume of the monitor too much may result in howling of the camera microphone.

## ■ Using Stereo Type Earphone Jack

When a stereo type earphone jack is connected, perform the following setting to output stereo sound.

**1** Set the [MONITOR SELECT] switch to "BOTH".

**2** Set [Main Menu] → [A/V Out] → [Audio Monitor] to "Stereo". (Page 93)

Only audio from [CH-1] is output through the monitor speaker.

**Memo :**

- You can set the volume of the alarm tone with [Alarm Level] in the [Main Menu] → [Others] menu. ("Off"/"Low"/"Middle"/"High") (Page 93)



# Time Code and User's Bit

Time code and user's bit data are recorded with the video in this camera recorder. The time code and user's bit are displayed on the viewfinder and LCD screens during playback or recording. (Status screen)

## Displaying Time Code and User's Bit

The time code and user's bit are displayed on the viewfinder and LCD screens during playback or recording. The display differs according to the menu settings.

**1** Set [Main Menu] → [LCD/VF] → [Status Display] → [TC/UB] to "On". (☞ Page 91)

Time code or user's bit data is displayed on the status screen.

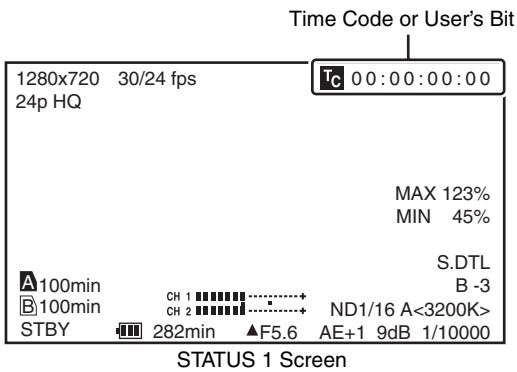

**2** Select the display with the [TC DISPLAY] switch on the LCD monitor.

Select time code display (TC) or user's bit display (UB).

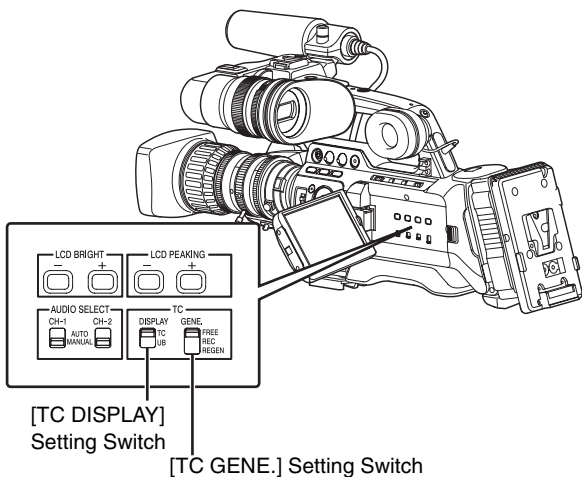

**Memo :**

- When [TCG Source] in the [TC/UB] menu is set to "Internal", the built-in time code generator number is displayed.
- When [TCG Source] in the [TC/UB] menu is set to "External", the value of the external time code generator input to the [TC IN] terminal is displayed.
- Time code display for [IEEE1394] input is not supported.
- Values recorded on the SDHC card is displayed in Media mode.

Setting	Display	LCD/VF Display	VIDEO Output Display
TC	Time Code	When [Main Menu] → [LCD/VF] → [Status Display] → [TC/UB] is set to "On", time code or user's bit is displayed during the following status display and information display mode of the LCD screen. ■ STATUS 1 screen in Camera mode ■ STATUS 1, STATUS 2 screens in Media mode (SD)	When [Analog Out Char.] or [SDI Out Char.] in the [A/V Out] menu is set to "On", time code or user's bit is displayed in the respective video output images during the LCD/VF display setting on the left.
UB	User's Bit		

## Time Code Operation Mode

Three types of time code operation can be selected with the [TC GENE.] switch. They are "FREE", "REC", and "REGEN".

\* The [TC GENE.] selection switch is enabled when [TCG Source] in the [TC/UB] menu is set to "Internal".

Setting	Mode	Description
FREE	FreeRun mode	The time code operates in the run mode at all times regardless of the recording status. It continues to run even when the power of the camera recorder is turned off. *
REC	RecRun mode	The time code operates in the run mode during recording. It continues to run in the order of the recorded clips as long as the SDHC card is not replaced. If the SDHC card is removed and recording is made on another card, time code will be recorded on the new card from where it was left off in the previous card.
REGEN	Regen mode	The time code operates in the run mode during recording. When the SDHC card is replaced, the last time code recorded on the card is read and recorded on a new card so that the time code continues in running order. (☞ Page 52)

\* When [Rec Mode] in the [Record Set] menu is set to "Variable Frame", time code operation enters RecRun mode.

# Using the Internal Time Code Generator

## Presetting the Time Code

Time code and user's bit data generated from the internal time code generator are recorded.

This section describes how to set [TC Preset] in the [TC/UB] menu. (☞ Page 88)

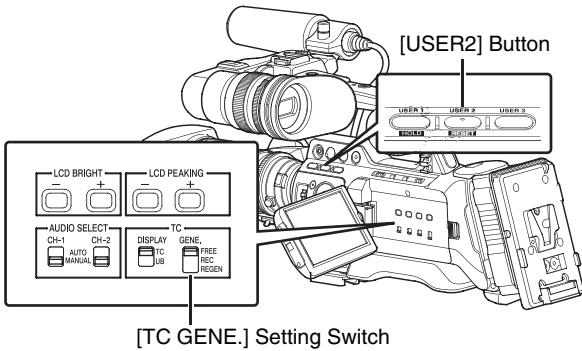

### Memo :

- When the frame rate setting in [Main Menu] → [Record Set] → [Record Format] → [Frame & Bit Rate] is “50, 25, 24”, settings cannot be made in [Drop]. (☞ Page 75)
- You can configure the setting without accessing the [TC/UB] menu screen. (☞ Page 51)

## Required Settings Before Preset

**1** Set [Main Menu] → [TC/UB] → [TCG Source] to “Internal”. (☞ Page 88)

**2** Set the [TC GENE.] switch to “REC” or “FREE”.

[REC]	Preset data in the time code generator operates in run mode during recording mode. Set this when recording continuous time code in connecting frames.
[FREE]	Time code starts to operate in run mode from the preset time in the time code generator.

**3** Select the framing mode for the time code generator (only when the frame rate setting is “60” or “30”).

Set using [Main Menu] → [TC/UB] → [Drop]. (☞ Page 88)

[Drop]	Sets the run mode of the time code generator to drop frame mode. Use this setting when placing emphasis on the recording time.
[Non Drop]	Sets the run mode of the time code generator to non-drop frame mode. Use this setting when placing emphasis on the number of frames.

### Memo :

#### Drop frame/non-drop frame mode

- When the frame rate setting in [Main Menu] → [Record Set] → [Record Format] → [Frame & Bit Rate] is 60 (30), the actual number of frames per second is approximately 59.94 (29.97). However, the time code processing standard is 60 (30) frames. To make up for the frame number discrepancy, the drop frame mode (Drop) drops the 00 frame and 01 frame every minute except for minutes that are multiples of 10.
- On the other hand, the non-drop frame mode (Non Drop) does not drop frames and ignores the discrepancy with the actual time.

# Using the Internal Time Code Generator (continued)

## Presetting the Time Code (continued)

### Setting Time Code

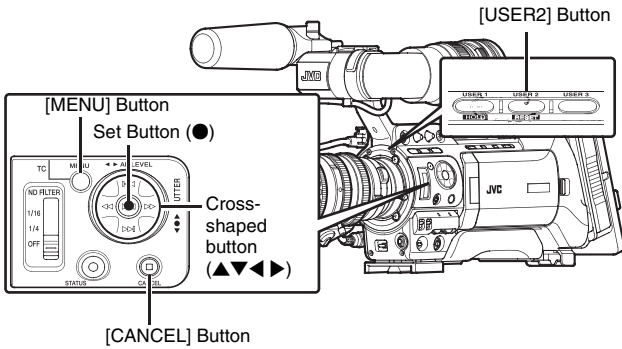

**1** Select [Main Menu] → [TC/UB] → [TC Preset] and press the Set button (●). (☞ Page 88)  
The [TC Preset] screen appears.

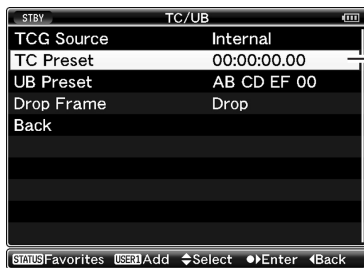

[TC/UB] Menu Screen

**Memo :**

- When the [TC GENE.] switch is set to “REGEN”, the parameter is displayed as “Regeneration” and cannot be selected.
- When [Main Menu] → [TC/UB] → [TCG Source] is set to “External”, the parameter is displayed as “External” and cannot be selected.

**2** Set the time code (hour, minute, second, frame).

Use the cross-shaped button (◀▶) to place the cursor at the item to set, then the cross-shaped button (▲▼) to change the values.

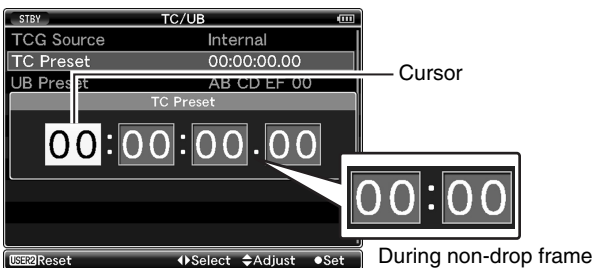

[TC Preset] Screen (During drop frame)

**Memo :**

- Press the [USER2] button to reset each digit to “0”. The cursor moves to the time digit (left).

**3** Check the values and press the Set button (●).

- The time code is set and the screen returns to [TC/UB].
- To cancel the setting, press the [CANCEL] button.

**4** Press the [MENU] button.

Returns to the normal screen.

## Presetting the User's Bit

You can add an 8-digit hexadecimal number as the user's bit to the recorded image.

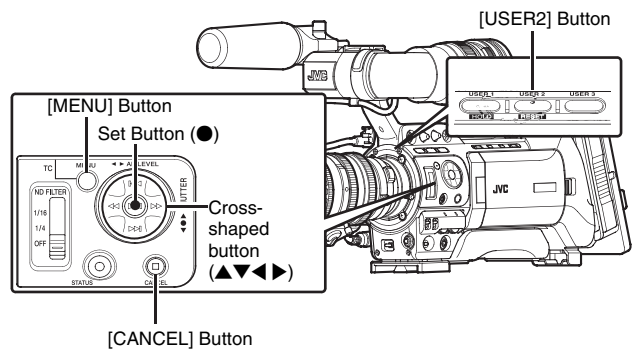

**1** Set [Main Menu] → [TC/UB] → [TCG Source] to “Internal”. (☞ Page 88)

**2** Select [Main Menu] → [TC/UB] → [UB Preset] and press the Set button (●). (☞ Page 88)

The [UB Preset] setting screen appears.

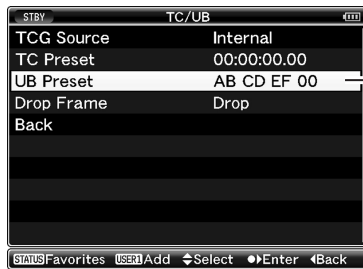

[TC/UB] Menu Screen

**Memo :**

- When the [TC GENE.] switch is set to “REGEN”, the parameter is displayed as “Regeneration” and cannot be selected.
- When [Main Menu] → [TC/UB] → [TCG Source] is set to “External”, the parameter is displayed as “External” and cannot be selected.

**3** Use the cross-shaped button (◀▶) to place the cursor at the item to set, then use the cross-shaped button (▲▼) to change the values.

Numbers between 0 and 9 or alphabets between A and F can be specified for the user's bit.

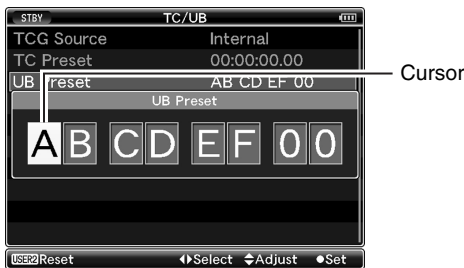

[UB Preset] Screen

**Memo :**

- Press the [USER2] button to reset each digit to "0". The cursor moves to the left.

**4** Check the values and press the Set button (●).

- The time code is set and the screen returns to [TC/UB].
- To cancel the setting, press the [CANCEL] button.

**5** Press the [MENU] button.

Returns to the normal screen.

## Setting Time Code Without Opening the Menu

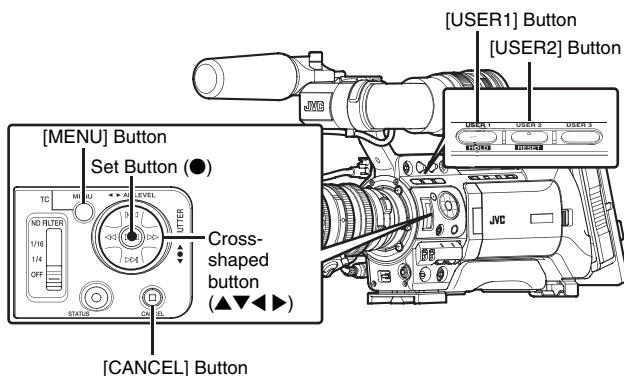

**Memo :**

- Settings cannot be made in the following cases.
  - [TCG Source] in the [TC/UB] menu is set to "External".
  - [TC GENE.] switch is set to "REGEN".
  - Menu screen is displayed.
  - The camera recorder is not in the Camera mode. (Except AUX Mode)

## Required Settings Before Preset (☞ Page 49)

- Set [TCG Source] in the [TC/UB] menu to "Internal".
- Set the [TC DISPLAY] switch to "TC".
- Set the [TC GENE.] switch to settings other than "REGEN".

## Setting Time Code

**1** Hold down the [MENU] button and press the [USER1] button.

The [TC Preset] setting screen appears.



[TC Preset] Screen

(During drop frame)

**2** Set the time code (hour, minute, second, frame).

Use the cross-shaped button (◀▶) to place the cursor at the item to set, then the cross-shaped button (▲▼) to change the values.

**Memo :**

- Press the [USER2] button to reset each digit to "0". The cursor moves to the time digit (left).

**3** Check the values and press the Set button (●).

- The time code is set and the screen returns to the normal screen.
- To cancel the setting, press the [CANCEL] button.

**Note :**

- Editing will be canceled and the screen will close under the following situations.
  - The [TC DISPLAY] switch is selected during editing.
  - The camera recorder is switched to the Media mode.
- When editing time code, operations of the [USER1], [USER2], [USER3] buttons that are set in the [Main Menu] → [Camera Function] → [Switch Set] menu are disabled. [USER2] functions as the number reset button. (☞ Page 79)

## Using the Internal Time Code Generator (continued)

### Setting User's Bit Without Opening the Menu

**Memo :**

- Settings cannot be made in the following cases.
  - [TCG Source] in the [TC/UB] menu is set to "External".
  - [TC GENE.] switch is set to "REGEN".
  - Menu screen is displayed.
  - The camera recorder is not in Camera mode. (Except AUX mode)

### Required Settings Before Preset (Page 49)

- Set [TCG Source] in the [TC/UB] menu to "Internal".
- Set the [TC DISPLAY] switch to "UB".
- Set the [TC GENE.] switch to settings other than "REGEN".

### Setting User's Bit

**1** Hold down the [MENU] button and press the [USER1] button.

The [UB Preset] setting screen appears.



[UB Preset] Screen

### 2 Set the user's bit.

Use the cross-shaped button (◀▶) to place the cursor at the item to set, then the cross-shaped button (▲▼) to change the values.

**Memo :**

- Press the [USER2] button to reset each digit to "0". The cursor moves to the left.

### 3 Check the values and press the Set button (●).

- The user's bit is set and the screen returns to the normal screen.
- To cancel the setting, press the [CANCEL] button.

**Note :**

- Editing will be canceled and the screen will close under the following situations.
  - The [TC DISPLAY] switch is selected during editing.
  - The camera recorder is switched to the Media mode.

**Note :**

- When editing time code, operations of the [USER1], [USER2], [USER3] buttons that are set in the [Main Menu] → [Camera Function] → [Switch Set] menu are disabled. [USER2] functions as the number reset button. (Page 79)

### Recording Time Code in Continuation of the Recorded Time Code on SDHC card

This camera recorder is equipped with the time code reader.

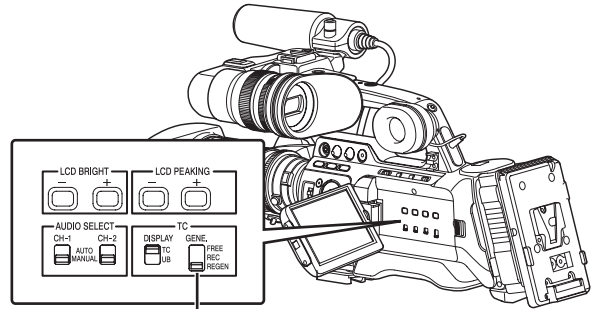

[TC GENE.] Setting Switch

**1** Set [Main Menu] → [TC/UB] → [TCG Source] to "Internal". (Page 88)

**2** Set the [TC GENE.] switch on the inner panel of the LCD to "REGEN".

When the camera recorder enters from recording standby mode to recording mode, it reads the time code already recorded on the SDHC card and records the new time code in continuation of that value.

The same data as the user's bit already recorded on the SDHC card is recorded.

**Memo :**

- When the [TC GENE.] switch is set to "REGEN", the framing mode of the time code follows the settings in [Drop] of the [TC/UB] menu instead of the clip settings. (Page 88)

## Synchronizing Time Code with External Time Code Generator

This camera recorder comes with a time code input terminal ([TC IN]).

An external time code generator can be connected to the [TC IN] terminal to enable synchronization with the SMPTE/EBU LTC time code.

**Memo :**

- After synchronization (slave lock) is complete, the built-in time code generator continues to run even when there is no input from the external time code generator.



## Connection

### ■ When connecting external time code generator to a master device

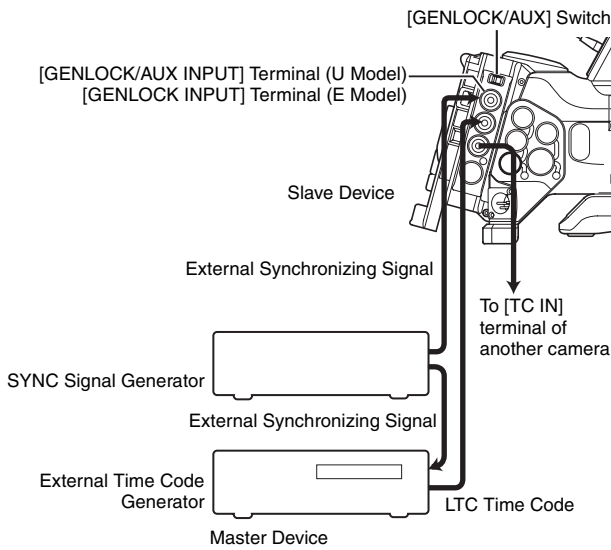

**1** Input the external synchronizing signal to the external time code generator and the [GENLOCK/AUX INPUT] terminal of this camera recorder.

Make use of BB signal or HDTV 3 level synchronizing signal as the external synchronizing signal.

#### Note :

- If the power of the camera recorder is turned ON/OFF during input of the external synchronizing signal, the screen may be disrupted for a few seconds. This is not a malfunction.

**2** Input the SMPTE/EBU LTC time code from the external time code generator to the [TC IN] terminal of this camera recorder.

### ■ When connecting multiple units of this camera recorder with one as the master and the rest as slave devices

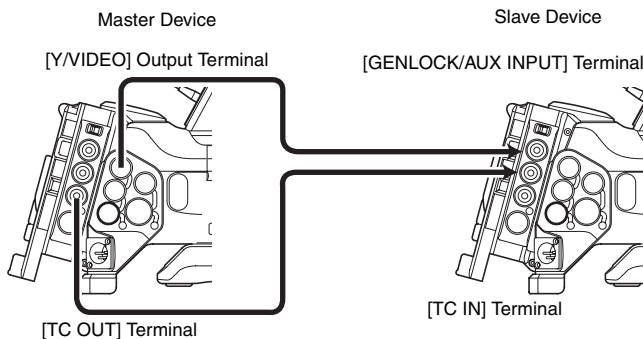

**1** Connect the [TC OUT] terminal of the master device to the [TC IN] terminal of the slave device.

**2** Connect the [Y/VIDEO] terminal of the master device to the [GENLOCK INPUT] terminal of the slave device.

## Settings on the Camera Recorder

- 1** Set to the Camera mode. (☞ Page 8)
- 2** Set the [GENLOCK/AUX] selection switch to "GENLOCK". (U model)
- 3** Set [Genlock Input] in the [Others] menu to "BNC". (☞ Page 93)
- 4** Set [TCG Source] in the [TC/UB] menu as follows.
  - Slave device : Set to "External"
  - Master device : Set to "Internal"
- 5** Set the LCD monitor or viewfinder as follows.
  - Viewfinder : Set to the STATUS 1 screen display (☞ Page 108)
  - LCD monitor : Set to the enlarged status display screen (☞ Page 110)

The input and synchronizing status of the external time code generator are displayed as follows.

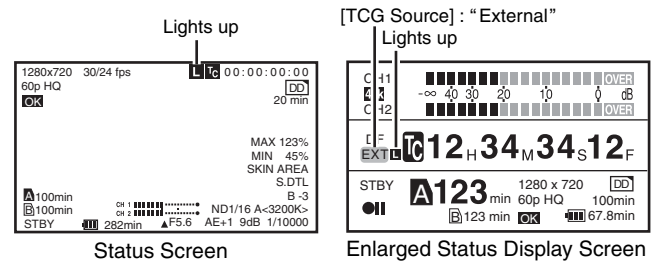

## Camera Recorder Operation

**1** Set the external time code generator or master device, and run the time code.

- When the built-in time code generator is synchronized with the input of the external time code generator, **L** on the STATUS 1 screen or enlarged status display screen will light up.
- If the time code is not synchronized or when there is no time code input, **L** does not light up.

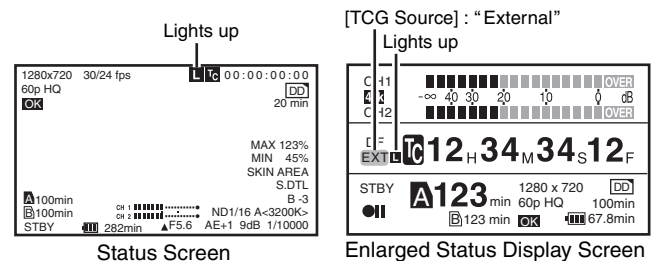

#### Memo :

- After synchronization is complete, the built-in time code generator will continue to run even when the external time code generator or master device is disconnected.
- The user's bit becomes the data of the external time code generator or master device.

# Setting Zebra Pattern

When the luminance level range for displaying zebra patterns is specified, diagonal lines (zebra pattern) are displayed at areas with the specified luminance levels during shooting.

## Specify the brightness (luminance) level range for displaying zebra pattern

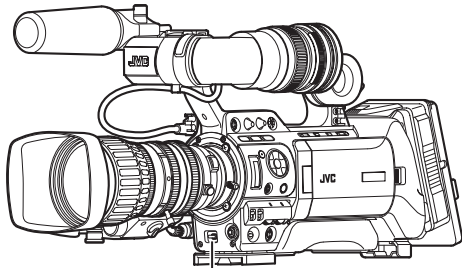

[ZEBRA ON/OFF] Switch

Specify the upper (Top1, Top2) and lower (Bottom1, Bottom2) limits of the luminance level.

### 1 Set the zebra display pattern.

- Select the display pattern in [LCD/VF] menu → [Shooting Assist] → [Zebra].

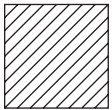

[Zebra1] Display

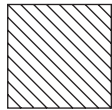

[Zebra2] Display

### 2 Specify the brightness (luminance) level range for displaying zebra pattern.

Specify the upper (Top1, Top2) and lower (Bottom1, Bottom2) limits of the luminance level in [LCD/VF] menu → [Shooting Assist] → [Zebra].

Item	Settings	Options
Zebra	Zebra display pattern	1Pattern 2Patterns
Top1	Upper luminance limit for displaying [Zebra1]	5 % - 100 %, Over (in 5 % increments)
Bottom1	Lower luminance limit for displaying [Zebra1]	0 % - 100 % (in 5 % increments)
Top2	Upper luminance limit for displaying [Zebra2]	5 % - 100 %, Over (in 5 % increments)
Bottom2	Lower luminance limit for displaying [Zebra2]	0 % - 100 % (in 5 % increments)

**Memo :**

- “Top2” and “Bottom2” cannot be set if [Zebra] is set to “1Pattern”.
- When the specified range of two zebra patterns overlaps, the two zebra patterns overlap and are displayed in a grid.

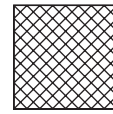

### 3 Display the zebra pattern.

Set the [ZEBRA ON/OFF] switch in front of the camera recorder to “ON” to display the zebra pattern at the specified range.

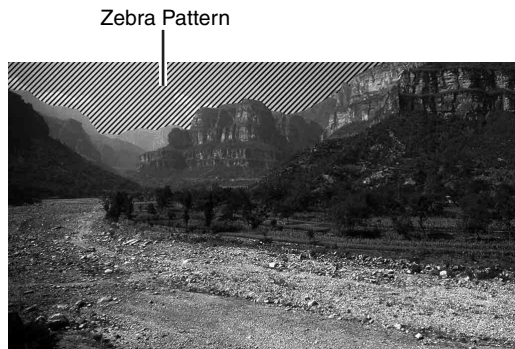



# Setting Spot Meter

The brightness of the object during shooting is displayed. This function is useful when setting video or stage lighting or when specifying camera exposure. A cursor indicating the location and the brightness (%) of that location are displayed in the images shown on the LCD monitor and viewfinder screens.

- Zebra patterns display the brightness of output video signals. (☞ Page 54)
- This function allows you to check the brightness of input images from the lens without depending on image processing such as gamma curve. The dynamic range of the camera recorder is 300 % and a brightness range of 0 % to 300 % and above is displayed.

**Memo :**

- Spot meter may not be consistent with the zebra display range. When [Gamma] in the [Camera Process] menu is set to "Cinema" or "Film Out", the 100IRE output is not consistent with the 100 % display. (☞ Page 83)
- When an object of more than 300 % luminance is detected, it is displayed as 300 %.

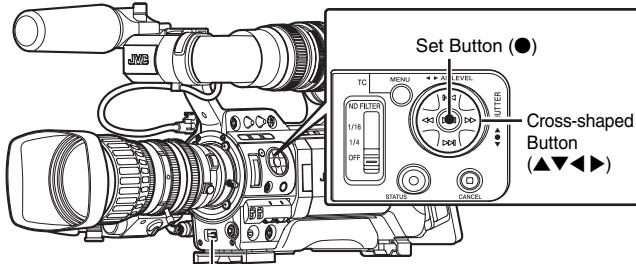

[SKIN AREA/SPOT METER] Switch

- 1 Select "Spot Meter" in [SKIN A./SPOT M.] of the [Main Menu] → [Camera Function] → [Switch Set] menu. (☞ Page 80)
- 2 Select one of the following from [SPOT METER]. (☞ Page 80)

Item	Settings	Color of Frame Indicating the Position
[Max&Min]	Displays the brightness (%) and positions of the brightest and darkest areas in the screen. Frames may also be stopped at the current positions.	[Max] : Green [Min] : Yellow
[Max]	Displays the brightness (%) and position of the brightest area in the screen. Frames may also be stopped at the current positions.	Green
[Min]	Displays the brightness (%) and position of the darkest area in the screen. Frame may also be stopped at the current positions.	Yellow
[Manual]	Displays the brightness (%) of the specified position.	Green (Blinks in red when specifying the position)

- 3 Flip the [SKIN AREA/SPOT METER] switch of the camera recorder.

The operation switches as below when the [SKIN AREA/SPOT METER] switch is flipped.

■ When [Max&Min]/[Max]/[Min] is selected

- ① [SPOT METER ON] is displayed when the switch is flipped. Cursors appear according to the settings. The positions of the brightest (Max) and darkest (Min) areas in the screen are automatically detected with regard to the changes of the object, and the brightness of these areas is displayed.

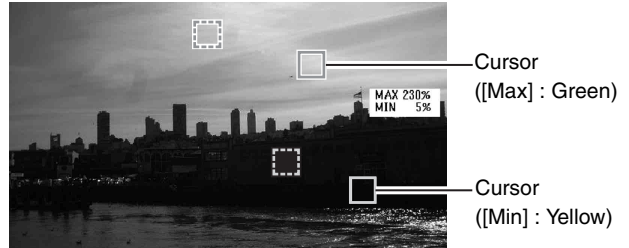

- ② [SPOT METER FIXED] is displayed when the switch is flipped. Automatic detection stops. Frames are fixed at the stopped positions and the brightness is displayed.

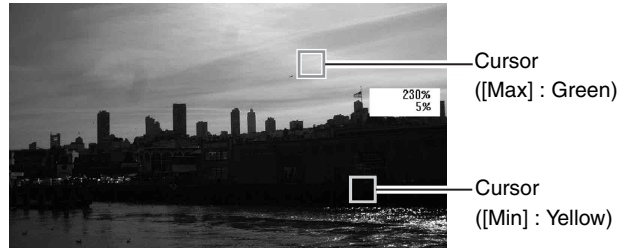

- ③ [SPOT METER OFF] is displayed when the switch is flipped. Displays of cursors and brightness disappear.



- ④ Returns to the state in ①.

## Setting Spot Meter (continued)

### ■ When [Manual] is selected

- ① [SPOT METER FIXED] is displayed when the switch is flipped. The brightness of the cursor position is displayed.

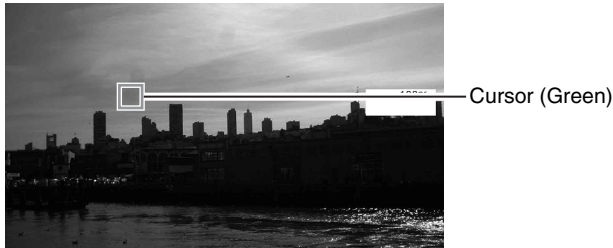

- ② [SPOT METER OFF] is displayed when the switch is flipped. Displays of cursors and brightness disappear.



- ③ [SPOT METER SELECT] is displayed when the switch is flipped. The cursor blinks in red. Move the cursor with the cross-shaped button (▲▼◀▶) to specify the position to display the brightness. When the position is decided, press the Set button (●) or flip the switch to confirm.

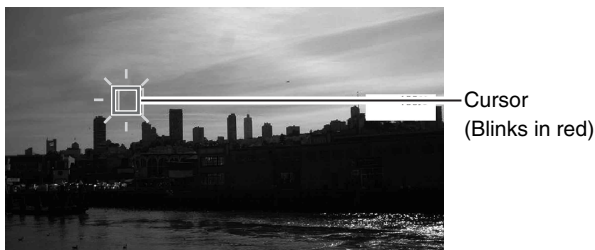

- ④ Returns to the state in ①.

### Memo :

- When moving the cursor position, [SHUTTER]/[AE LEVEL] control is disabled.
- You can also decide the position of the cursor with the Set button (●).
- When the brightness is 0 % in the entire screen, the frame is fixed in the center.
- If the cursor is outside the “4:3” range, changing the [Aspect Ratio] item in the [Record Format] menu from “16:9” to “4:3” restores the cursor to the default position. (Page 75)

## Viewing Recorded Videos Immediately (Clip Review)

You can check (review) the last recorded video clip on the screen.

However, the video clip cannot be played back if the settings of the camera recorder are different from the video format (Camera Resolution/Frame & Bit Rate) of the clip. (Page 75)

### Memo :

- To use this function, assign “Clip Review” to any of the [USER1], [USER2], [USER3] buttons or the [RET] button on the lens.

\* [Main Menu] → [Camera Function] → [Switch Set] → [LENS RET]/[USER1]/[USER2]/[USER3] → “Clip Review” (Page 79)

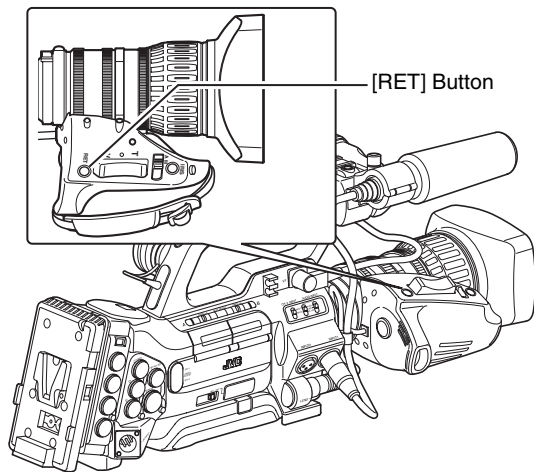

### 1 Press the button assigned with the “Clip Review” function during standby (“STBY” is displayed).

Playback of the configured section starts.

### Memo :

- The video clip is played back according to the [Clip Review] settings in the [Camera Function] menu. By default setting (Last 5 sec), the last 5 seconds of the clip is played back. (Page 79)
- When playback is complete, the camera recorder exits Clip Review and returns to “STBY” (recording standby) mode.

**Note :**

- During Clip Review, only the [CANCEL] and [REC] buttons are enabled. Press the [CANCEL] button to cancel clip review and return to “STBY” (recording standby) mode. Press the [REC] button to cancel clip review and enter recording mode. It will take some time to start recording after the button is pressed.
- When the last clip is less than 5 seconds, the whole clip is played back.
- Only video clips in the currently selected slot can be reviewed.
- When there are no clips in the selected slot, Clip Review function is disabled.
- Clip Review is unavailable when Clip Continuous Rec is paused (STBY $\square$ , yellow text). To operate Clip Review, use the [CANCEL] button to set to “STBY $\square$ ” (white text) first. (☞ Page 59)
- Clip Review is unavailable when the camera recorder is connected to an external equipment and the equipment is in recording state.

## Assigning Functions to User Buttons

You can assign functions to the [USER1], [USER2], and [USER3] buttons.

By assigning functions to the [USER1], [USER2], and [USER3] buttons, the usability of the camera recorder is enhanced.

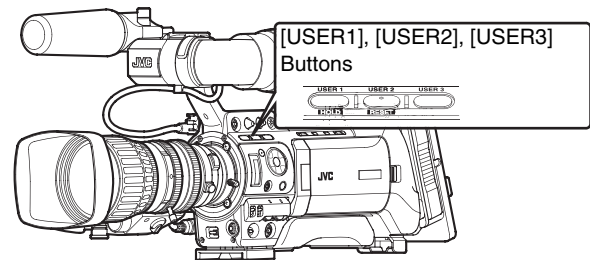

### 1 Assign functions to the [USER1], [USER2], and [USER3] buttons from the menu. (☞ Page 79)

Set each of the [USER1], [USER2], and [USER3] items in the [Main Menu] → [Camera Function] → [Switch Set] menu.

**Memo :**

- Operations of the [USER1], [USER2], and [USER3] buttons are interlocked with the menu settings.
- When the menu screen is displayed, these buttons function as the menu operation buttons.  
(☞ Page 70 [Basic Operations in Menu Screen])

## Protecting Important Scenes (OK Mark Function)

You can append OK marks to the clips for important scenes. Clips appended with OK marks cannot be deleted, thus protecting the important clips. In addition, you can display only the clips with OK marks in the thumbnail display during Media mode.

### Appending OK Marks During Recording

**1** Assign the “OK Mark” function to the [RET] button on the lens from the menu.

- Select [Main Menu] → [Camera Function] → [Switch Set] → [LENS RET] → “OK Mark”. (☞ Page 79)
- Append or delete the [OK] mark with every press of the [RET] button.
- When an OK mark is appended, “OK” appears at the top left of the status screen on the viewfinder/LCD monitor. (☞ Page 104, 111)

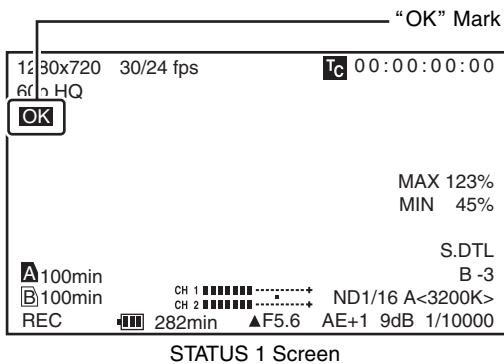

#### Memo :

- Clips appended with [OK Mark] cannot be deleted from the camera recorder using [Delete Clip]. (However, they will be deleted when the SDHC card is formatted.)
- When the camera recorder is in Media mode (SD Card mode), you can delete the [OK] marks appended during recording, or append/delete [OK] marks after shooting. (☞ Page 68 [Appending and Deleting OK Marks])

#### Note :

- When the write-protect switch on the SDHC card is set (⏏ is displayed), [OK] marks cannot be appended/deleted.

## Special Recording

Besides the normal recording mode, three special recording methods are available in this camera recorder. They are Pre Rec, Clip Continuous Rec, and Variable Frame Rec.

Select the mode from [Rec Mode] in the [Record Set] menu.

- \* Set using [Main Menu] → [Record Set] → [Rec Mode]. (☞ Page 76)

### Pre Rec

By setting the number of seconds in the [Pre Rec Time], you can start recording video and audio before actual recording starts based on the Pre Rec Time setting.

When starting actual recording while the camera recorder is in Recording Standby (STBY $\square$ ) mode, you can start recording a few seconds earlier based on the [Pre Rec Time] setting.

Using Pre Rec allows you to record a complete event without missing the initial scenes even if you start the recording late.

- \* Pre Rec Time can be set to “5sec”, “10sec”, or “20sec” in [Main Menu] → [Record Set] → [Pre Rec Time]. (☞ Page 76)

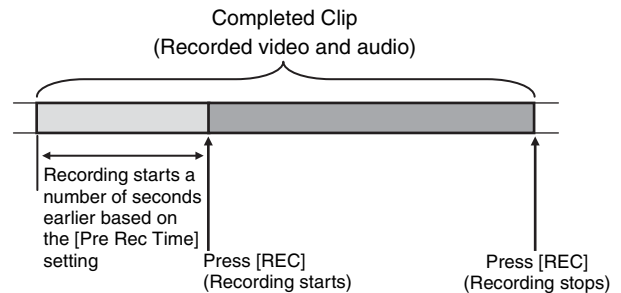

**1** Set [Rec Mode] to “Pre Rec”. (☞ Page 76)

- Set [Main Menu] → [Record Set] → [Rec Mode] to “Pre Rec”.
- The status display changes from “STBY” → “STBY $\square$ ”.

**2** Press the [REC] button to start recording in Pre Rec mode.

- The status display changes from “STBY $\square$ ” → “REC $\square$ ” and the card slot status indicator lights up in red.
- Press the [REC] button again to pause recording. The display changes from “REC $\square$ ” → “STBY $\square$ ” and the card slot status indicator lights up in green.

#### Note :

- When the interval between start and stop recording is short, “STBY $\square$ ” may not be displayed immediately after recording is complete. “REC $\square$ ” → “STBY $\square$ ” (STBY blinks in red) → “STBY $\square$ ” is displayed.
- When the SDHC card becomes full during recording, recording stops and “STOP $\square$ ” is displayed.

**Note :**

- Video and audio before the above mentioned time may not be recorded after recording starts in the following cases.
  - Immediately after power on
  - Immediately after recording stops
  - Immediately after switching from Media mode to Camera mode
  - Immediately after setting [Rec Mode]
  - Immediately after the end of Clip Review
  - Immediately after changing file format
  - Immediately after changing video format

## Clip Continuous Rec

In normal recording, when the recording stops, the image, audio, and accompanying data from the start till the end of the recording are recorded as one “clip” on the SDHC card. This mode allows you to consolidate several rounds of “start-stop recording” into one clip.

Example : In normal recording, three clips are generated as Recording 1, Recording 2, and Recording 3. However, recording in this mode generates only one clip.

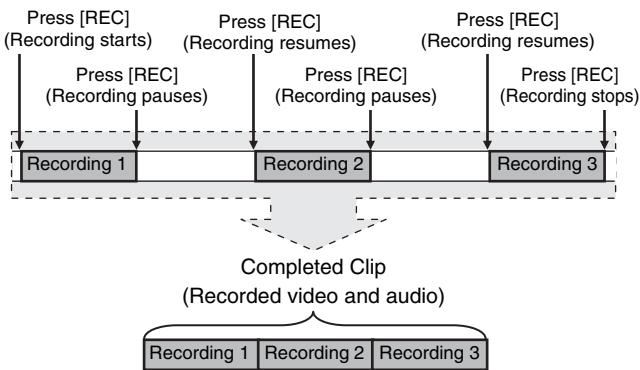

### 1 Set [Rec Mode] to “Clip Continuous”.

- Set [Main Menu] → [Record Set] → [Rec Mode] to “Clip Continuous”. (Page 76)
- The status display changes from “STBY” → “STBY”.

### 2 Start recording. (Recording 1)

- Press the [REC] button to start recording in Clip Continuous mode.
- The status display changes from “STBY” → “REC” and the card slot status indicator lights up in red.

### 3 Pause recording.

- Press the [REC] button again to pause recording. The display changes from “REC” → “STBY” (yellow text).
- The card slot status indicator remains lighted in red.

**Memo :**

- When the [CANCEL] button is pressed while the camera recorder is paused (STBY), the display changes from “STBY” (yellow text) → “STBY” (blinking yellow text) → “STBY” (white text). A “clip” is generated. The card slot status indicator lights up in green.

### 4 Resume recording. (Recording 2)

- Press the [REC] button again to resume recording. The display changes from “STBY” (yellow text) → “REC”.
- The card slot status indicator remains lighted in red.

### 5 Pause recording.

- Press the [REC] button again to pause recording. The display changes from “REC” → “STBY” (yellow text).
- The card slot status indicator remains lighted in red.

### 6 Resume recording. (Recording 3)

- Press the [REC] button again to resume recording. The display changes from “STBY” (yellow text) → “REC”.
- The card slot status indicator remains lighted in red.

### 7 Press and hold the [REC] button.

- Recording stops and the display changes from “REC” → “STBY”. A “clip” is generated.
- The card slot status indicator lights up in green.

### 8 Press the [REC] button again.

- The status display changes from “STBY” → “REC” and the card slot status indicator lights up in red.
- A new “clip” is generated from here.

**Memo :**

- The following operations cannot be performed while recording is paused (STBY, yellow text).
  - Clip Review operation (Page 56)
  - Switching SDHC card slots
  - Switching operation mode (Page 8)
- Files are split into sizes of 4 GB (or 30 minutes) regardless of the menu settings.

**Note :**

- Do not remove the SDHC card during recording (REC, red text) or recording pause (STBY, yellow text).
- To remove the SDHC card in “Clip Continuous” mode, press the [CANCEL] button, check that “STBY” (white text) is displayed and the card slot status indicator is lighted in green before you remove the card.
- When the SDHC card becomes full during recording, recording stops and “STOP” is displayed.
- When the [POWER] switch is turned off during recording or recording pause, recording stops and power is cut off after a clip is generated.
- If the power is cut off due to low battery power, a proper clip may not be generated.

# Special Recording (continued)

## Variable Frame Rec

Shooting in this mode allows you to obtain smooth slow motion or quick motion videos.

Using different frame rate settings for recording and playback, videos captured at normal speed can be played back more smoothly than those in low or high speed playback.

To enable Variable Frame Rec, the following two settings are required at the same time.

- [Camera Resolution] in the [Record Format] menu is set to "1280x720".
- [Frame & Bit Rate] in the [Record Format] menu is set to "30p (HQ)", "24p (HQ)", or "25p (HQ)".

## Number of Frames that can be Set

**1** Set [Camera Resolution] to "1280x720", then set [Frame & Bit Rate]. (☞ Page 76)

Set [Frame & Bit Rate] to "30p (HQ)", "24p (HQ)", or "25p (HQ)".

**2** Set [Rec Mode] to "Variable Frame". (☞ Page 76)

Set [Main Menu] → [Record Set] → [Rec Mode] to "Variable Frame".

**3** Select a recording frame rate from [Frame Rate]. (☞ Page 76)

The selectable frame rates are as shown below.

Record Format	Selectable Shooting Frame Rate											
1280x720	30p (HQ)	10	12	15	20	24	30	40	48	60	—	
	24p (HQ)	—	10	12	15	20	24	30	40	48	60	
	25p (HQ)	—	—	10	12.5	20	25	40	50	—	—	
Effect during playback		Quick motion				Standard			Slow motion			

### Memo :

- When [AE LEVEL] in the [Main Menu] → [Camera Function] → [Switch Set] menu is set to "AE LEVEL/VFR", you can use the cross-shaped button (◀▶) to select the frame rate during Variable Frame Rec. In modes other than Variable Frame Rec, the cross-shaped button (◀▶) functions as the [AE LEVEL] setting button. (☞ Page 80)

### Note :

- The recording frame rate cannot be changed during recording. To change the frame rate, stop the recording first and perform the change.
- When the [TC GENE.] switch located on the inner panel of the LCD is set to "FREE", videos are recorded in Rec (RecRun) time code.
- Audio cannot be recorded. A ⊗ mark appears in the audio level meter display. (☞ Page 104)
- Depending on the settings, images beyond the recording stop position may be recorded and it may take time for the camera recorder to enter "STBY" mode.



# Playing Back Recorded Clips

To play back clips recorded on SDHC cards, switch to the Media mode (SD Card mode). Press the [CAM/MEDIA] selection button in Camera mode to enter SD Card mode. A thumbnail screen of the clips recorded on the SDHC card is displayed. You can play back the selected clip on the thumbnail screen.

**Memo :** \_\_\_\_\_  
 ● When an SDHC card without any clips is inserted, "No Clips" is displayed.

## Operation Buttons

Use the operation buttons on the side control panel of the camera recorder to operate the thumbnail screen.

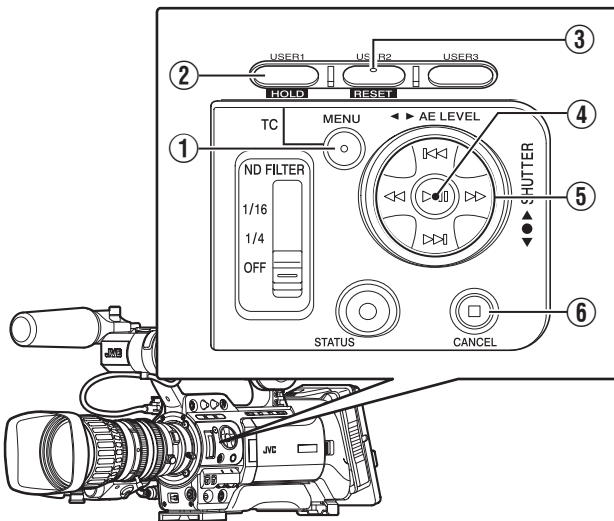

Name	Description
① [MENU] Button	Displays the thumbnail screen menu. Press this button to close the menu screen during menu display and return to the normal screen.
② [USER1] Button	Appends (or deletes) an OK mark on the selected clip.
③ [USER2] Button	Deletes the selected clip.
④ Set (Play) Button	Sets the values and items. (Confirm) Plays back the selected clip.
⑤ Cross-Shaped Button (▲▼◀▶)	▲ : Moves the cursor upward. ▼ : Moves the cursor downward. ◀ : Moves back to the previous item. ▶ : Moves forward to the next item. (To enter sub-menus or display pop-up menus.)
⑥ [CANCEL] (Stop) Button	Cancels settings and returns to the previous screen. Stops video playback.

## Thumbnail Screen

The thumbnail screen is available in "No Detailed Properties (4x3 thumbnails)" and "Detailed Properties (4x1 thumbnails)" displays.

Use the thumbnail menu [Detailed Properties] to switch display. (Page 65)

The first frame of the recorded clip on the SDHC card is displayed as the thumbnail.

Thumbnails are displayed in order of recording from the oldest to most recent.

### ■ No Detailed Properties (4x3 Thumbnails) Screen

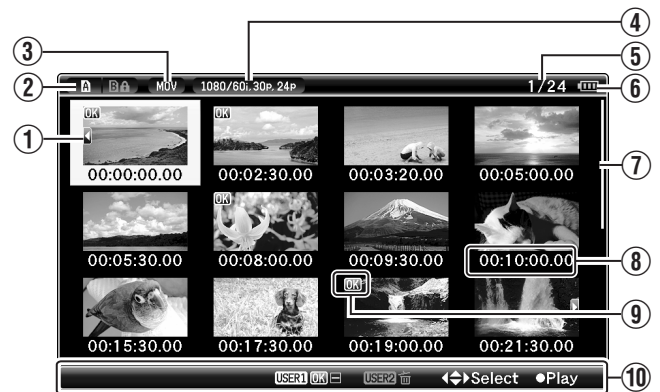

Name	Description
① Cursor	Indicates the selected clip. Use the cross-shaped button (▲▼◀▶) to move the cursor. After power is turned on and SDHC card is inserted, or when the camera recorder is switched to Media mode (SD Card mode), the cursor is positioned on top of the latest clip. When the camera recorder changes to the thumbnail screen during playback, the cursor is positioned on the clip that was played back. If you play back the same clip again, it will continue from where it was left off. The default position of the cursor when SDHC card slot is switched is on the previously selected clip before the switch.  <b>■ Example of the moving order of the cursor (total 22 clips)</b>



# Playing Back Recorded Clips (continued)

## Thumbnail Screen (continued)

### ■ No Detailed Properties (4x3 Thumbnails) Screen (continued)

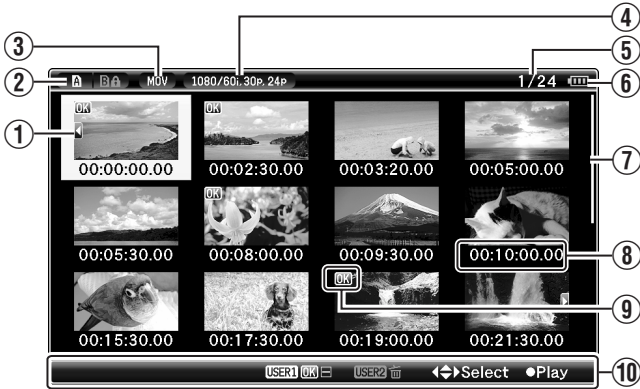

Name	Description
② SDHC Card	Displays the status of the inserted SDHC card, selected SDHC card, write-protect switch, and the need for restoring. Use the [SLOT SELECT] switch to switch slots. Clips in slot A and B cannot be displayed at the same time. <b>A</b> : Write-protect switch of the SDHC card in slot A is set. <b>B!</b> : SDHC card in slot B needs to be restored or formatted, or is an unsupported SDHC card.
③ File Format	Shows the file format of the currently displayed clips. Only clips with the resolution (“HD (MPEG2)” or “SD (DV)”) selected in [System Definition] are displayed. (Page 75) * Depends on the settings in [Record Set] → [Record Format] → [File Format] on the [Main Menu] screen. (Page 75)

Name	Description
④ Video Format	Displays the video format (Camera Resolution/Frame Rate) that allows playback and thumbnail display. Five types including [1080/60i, 30p, 24p], [1080/50i, 25p], [720/60p, 30p, 24p], [720/50p, 25p], [480/60i] (U model) and [576/50i] (E model). Clips of other video formats are represented in alternative display. Clips that are in alternative display cannot be played back with the current video format settings.
⑤ Number of Clips	Displays the [running number/total number of clips] of the displayed clips.
⑥ Remaining Battery Power	<ul style="list-style-type: none"> <li> : Ample battery power.</li> <li> : Slightly reduced battery power.</li> <li> : Low battery power.</li> <li> : Empty battery power. (Blinks in red)</li> <li> : External power supply connected.</li> </ul> <b>Memo:</b> <ul style="list-style-type: none"> <li>● If the battery in use is not a recommended one, the battery mark which indicates the battery level may not appear.</li> </ul>
⑦ Scroll Bar	Indicates the scroll position. When there is a black space below the scroll bar (white), this indicates further pages. When the scroll bar (white) is at the bottom, this indicates the last page.

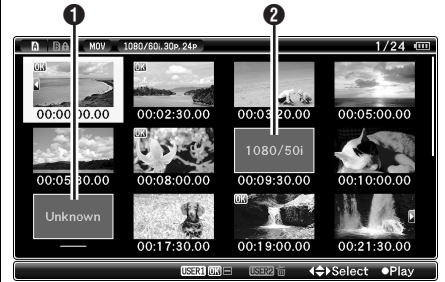

- ① A clip with corrupted management information. It cannot be played back even if you press the playback button.
  - ② A clip that cannot be played back nor displayed in thumbnail with the current video format settings. It cannot be played back even if you press the playback button. The format of the clip is displayed.
- \* Depends on the settings in [Record Set] → [Record Format] → [System Definition], [Camera Resolution], and [Frame & Bit Rate] items of the [Main Menu] screen. (Page 75)

Name	Description
⑧ Thumbnail Text	<p>Displays the time code or date/time at the start of clip recording. Date/time is displayed in the local time of the shooting location.</p> <p>Set whether to display "TC" or "Date/Time" in the thumbnail menu [Thumbnail Text]. (☞ Page 65)</p> <p>Data/time display depends on the settings in [LCD/VF] → [Status Display] → [Date Style] of the [Main Menu] screen. (☞ Page 91)</p> <p>Time is displayed in 24-hour display regardless of the [Time Style] setting.</p>
⑨ Clip Mark	<p>Displays clip information (properties).</p> <div data-bbox="325 600 651 770" style="text-align: center;"> </div> <p><b>① OK Mark</b> Clip is appended with OK mark.</p> <p><b>Memo:</b> _____</p> <ul style="list-style-type: none"> <li>Clips appended with OK marks cannot be deleted on the camera recorder.</li> </ul> <hr/> <p><b>② Continued From Mark</b> This mark indicates that the current clip is continued from another SDHC card when recording is divided and made on several SDHC cards.</p> <p><b>③ Continue Mark</b> This mark indicates that the current clip will continue to another SDHC card when recording is divided and made on several SDHC cards.</p>
⑩ Operation Guide	Guide for the current operation buttons.
	Moves the clip cursor to the top/bottom/left/right.
	Plays back the selected clip.
	<p>Appends an OK mark to the selected clip. This is displayed when an OK mark is not appended to the clip. (☞ Page 68)</p> <p><b>Memo:</b> _____</p> <ul style="list-style-type: none"> <li>This is disabled when the SDHC card is locked. (Displayed in gray)</li> </ul>
	<p>Deletes the OK mark from the selected clip. This is displayed when an OK mark is appended to the clip. (☞ Page 69)</p> <p><b>Memo:</b> _____</p> <ul style="list-style-type: none"> <li>This is disabled when the SDHC card is locked. (Displayed in gray)</li> </ul>
	<p>Deletes the selected clip. (☞ Page 66)</p>

# Playing Back Recorded Clips (continued)

## Thumbnail Screen (continued)

### ■ Detailed Properties (4x1 Thumbnails) Screen



Name	Description
① Cursor	<p>Indicates the selected clip. Use the cross-shaped button (◀▶) to move the cursor.</p> <p>After power is turned on and SDHC card is inserted, or when the camera recorder is switched to Media mode (SD Card mode), the cursor is positioned on top of the latest clip.</p> <p>When the camera recorder changes to the thumbnail screen during playback, the cursor is positioned on the clip that was played back. If you play back the same clip again, it will continue from where it was left off.</p> <p>The default position of the cursor when SDHC card slot is switched is on the previously selected clip before the switch.</p> <p>■ Example of the moving order of the cursor (total 6 clips)</p>
② Scroll Bar	<p>Indicates the scroll position.</p> <p>When there is a black space on the right of the scroll bar (white), this indicates further pages.</p> <p>When the scroll bar (white) is at the right end, this indicates the last page.</p>

Name	Description										
③ Detailed Properties	<p>Shows the detailed properties of the selected clip. The following information is displayed.</p> <p>File Format : File format            Clip Name : Clip name            Resolution : Image size            Frame Rate : Frame rate            Bit Rate : Bit rate            Audio : Audio format            Start TC : Time code at the start of recording            End TC : Time code at the end of recording            Duration : Clip length            UB : User's bit            Creation Date : Date created</p> <p><b>Memo:</b> _____</p> <ul style="list-style-type: none"> <li>• The information of time and date displays in the following order, Year, Month, Date, Time, Minute, Second and Time zone.</li> <li>• “-” is the break character between Year, Month and Date for each, and “:” is the break character between Time, Minute and Second for each, and “T” is the break character Date and Time.</li> <li>• “Z” displays behind Time when Time zone is set to “UTC+00:00”.</li> </ul> <p><b>(Time and date display example)</b></p> <p>In case of “UTC+00:00” 21:18:50 on March 4th in 2009 (Western European time zone):            “2009-03-04T21:18:50Z”</p> <p>In case of “UTC-05:00” 10:13:15 on March 19th in 2009 (North American Eastern time zone):            “2009-03-19T10:13:15-05:00”</p> <hr/> <p>Variable Frame : Variable frame (only in Variable Frame Rec)</p>										
④ Operation Guide	<p>Guide for the current operation buttons.</p> <table border="1"> <tbody> <tr> <td>◀▶Select</td> <td>Moves the clip cursor to the left/right.</td> </tr> <tr> <td>●Play</td> <td>Plays back the selected clip.</td> </tr> <tr> <td>USER1 OK</td> <td> <p>Appends an OK mark to the selected clip. This is displayed when an OK mark is not appended to the clip. (☞ Page 68)</p> <p><b>Memo:</b> _____</p> <ul style="list-style-type: none"> <li>• This is disabled when the SDHC card is locked. (Displayed in gray)</li> </ul> </td> </tr> <tr> <td>USER1 OK</td> <td> <p>Deletes the OK mark from the selected clip. This is displayed when an OK mark is appended to the clip. (☞ Page 69)</p> <p><b>Memo:</b> _____</p> <ul style="list-style-type: none"> <li>• This is disabled when the SDHC card is locked. (Displayed in gray)</li> </ul> </td> </tr> <tr> <td>USER2</td> <td>Deletes the selected clip. (☞ Page 66)</td> </tr> </tbody> </table>	◀▶Select	Moves the clip cursor to the left/right.	●Play	Plays back the selected clip.	USER1 OK	<p>Appends an OK mark to the selected clip. This is displayed when an OK mark is not appended to the clip. (☞ Page 68)</p> <p><b>Memo:</b> _____</p> <ul style="list-style-type: none"> <li>• This is disabled when the SDHC card is locked. (Displayed in gray)</li> </ul>	USER1 OK	<p>Deletes the OK mark from the selected clip. This is displayed when an OK mark is appended to the clip. (☞ Page 69)</p> <p><b>Memo:</b> _____</p> <ul style="list-style-type: none"> <li>• This is disabled when the SDHC card is locked. (Displayed in gray)</li> </ul>	USER2	Deletes the selected clip. (☞ Page 66)
◀▶Select	Moves the clip cursor to the left/right.										
●Play	Plays back the selected clip.										
USER1 OK	<p>Appends an OK mark to the selected clip. This is displayed when an OK mark is not appended to the clip. (☞ Page 68)</p> <p><b>Memo:</b> _____</p> <ul style="list-style-type: none"> <li>• This is disabled when the SDHC card is locked. (Displayed in gray)</li> </ul>										
USER1 OK	<p>Deletes the OK mark from the selected clip. This is displayed when an OK mark is appended to the clip. (☞ Page 69)</p> <p><b>Memo:</b> _____</p> <ul style="list-style-type: none"> <li>• This is disabled when the SDHC card is locked. (Displayed in gray)</li> </ul>										
USER2	Deletes the selected clip. (☞ Page 66)										

## Playing Back

Use the operation buttons on the side control panel of the camera recorder to play back.

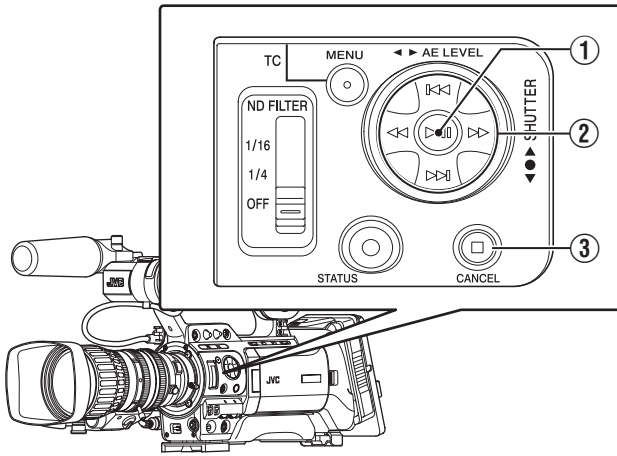

Name	Description
① ▷    Button	Plays back/pauses the selected clip.
② ◀◀/▶▶ Button	Skips in the reverse or forward direction.
◀◀/▶▶ Button	Fast forwards in the reverse or forward direction.
③ □ Button	Stops playback.

### 1 Select the clip to play back on the thumbnail screen.

Select the clip to play back with the cross-shaped button (▲▼◀▶).

### 2 Press the playback/pause button.

Playback of the selected clip starts.

## Time Code Playback

Time code or user's bit recorded on an SDHC card can be displayed on the LCD monitor and viewfinder.

### Memo :

- When [HD/SD-SDI Out] in the [A/V Out] menu is set to "HD-SDI" or "SD-SDI", time code is also output from the [HD/SD-SDI] output terminal. (Page 92)
- User's bit output from the [HD/SD-SDI] output terminal is used as a flag to determine valid video signals. Therefore, accurate values will not be output.
- If a section without time code is played back, the time code will stop. However, playback will continue.

## Thumbnail Menu

Press the [MENU] button during thumbnail display to display the thumbnail menu.

Press the [MENU] button during menu display to cancel the settings and exit the menu.

### Thumbnail Menu

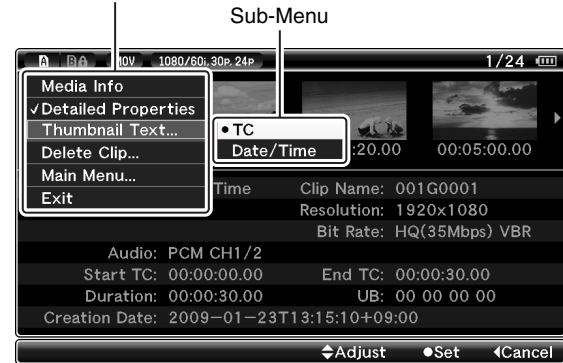

Thumbnail Menu Screen

Item	Function
<b>Media info</b>	Displays the information screen of the SDHC card.
<b>Detailed Properties</b>	For selecting the display method of the thumbnail screen. If a check is selected, the thumbnail screen will be displayed as [Detailed Properties (4x1 Thumbnail Screen)]. (Page 64)
<b>Thumbnail Text</b>	For selecting the display method for the thumbnail text on the thumbnail screen.
<b>TC</b>	Displays the recording start time code at the thumbnail text display area (below the thumbnail).
<b>Date/Time</b>	Displays the recording start date/time at the thumbnail text display area (below the thumbnail).
<b>Delete Clip</b>	For deleting clips. (Page 66)
<b>One Clip</b>	Deletes the selected clip.
<b>All Clips</b>	Deletes all clips that are displayed.
<b>Main Menu...</b>	Opens the [Main Menu] screen. (Page 74)
<b>Exit</b>	Exits and closes the menu.

# Deleting Clips

For deleting clips.

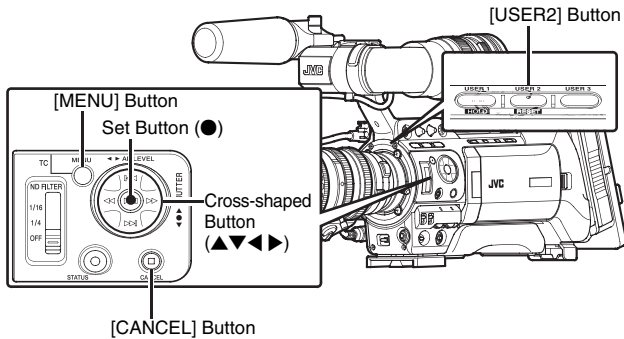

**Memo :**

- Clips appended with OK marks cannot be deleted on the camera recorder.
- Read-only clips can be deleted on a PC.

## Deleting One Clip

You can delete a selected clip with any of the following operations.

- ① Press [USER2] button when menu is not displayed.
- ② Perform [Delete Clip] → [One Clip] in thumbnail menu.

**Memo :**

- A clip cannot be deleted with the [USER2] button and menu operation ([Delete Clip] → [One Clip]) under the following situations.
  - A clip with OK mark is selected.
  - Write-protect switch of the SDHC card is set (🔒 is displayed).

## ■ During Thumbnail Screen

### ■ Deleting with [USER2] button

#### 1 Select the clip to delete.

Select the clip to delete with the cross-shaped button (▲▼◀▶).



#### 2 Press the [USER2] button.

A screen to confirm deletion appears.

#### 3 Select [Delete] using the cross-shaped button (▲▼), and press the Set button (●).

Deleting starts.



**Memo :**

- Button operations are unavailable during deletion. The deleting operation cannot be canceled.
- The cursor moves to the next clip (or previous clip if a next clip does not exist) after deletion.

## ■ Deleting with [Delete Clip] → [One Clip] in the menu

#### 1 Select the clip to delete.

Select the clip to delete with the cross-shaped button (▲▼◀▶).



#### 2 Press the [MENU] button.

The thumbnail menu screen appears.

#### 3 Select [Delete Clip] → [One Clip] and press the Set button (●).

A screen to confirm deletion appears.

**4** Select [Delete] using the cross-shaped button (▲▼), and press the Set button (●).

Deleting starts.



**Memo :** \_\_\_\_\_

- Button operations are unavailable during deletion. The deleting operation cannot be canceled.
- The cursor moves to the next clip (or previous clip if a next clip does not exist) after deletion.

**■ During Playback or Pause Screen**

**■ Deleting with [USER2] button**

**1** Press [USER2] button during clip playback.

A screen to confirm deletion appears.

**2** Select [Delete] and press the Set button (●).

Deleting starts.

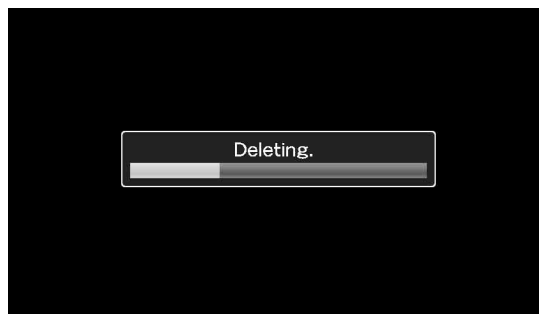

**Deleting All Clips**

Deletes all clips that are displayed.

**1** Press the [MENU] button.

The thumbnail menu screen appears.

**2** Select [Delete Clip] → [All Clips] in the menu.

A screen to confirm deletion appears.

**3** Select [Delete] and press the Set button (●).

Deleting starts.

**Memo :** \_\_\_\_\_

- Button operations are unavailable during deletion. The deleting operation cannot be canceled.
- The time taken to delete clips depends on the number of clips to be deleted.



# Appending and Deleting OK Marks

You can append OK marks to the clips for important scenes. Clips appended with OK marks cannot be deleted, thus protecting the important clips.

When the camera recorder is in Media mode (SD Card mode), you can delete the OK marks appended during recording, or append/delete OK marks after shooting.

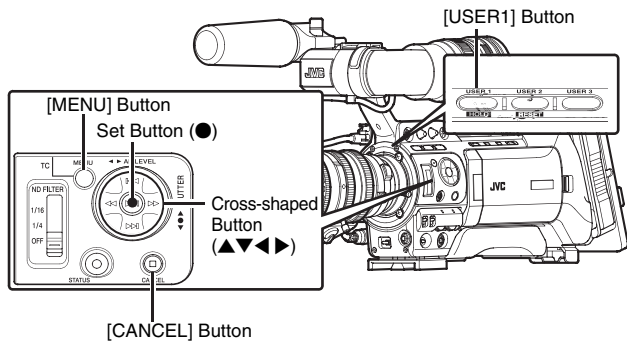

## Appending OK Marks

### ■ During Thumbnail Screen

1 Select a clip without an OK mark and press the [USER1] button.

An OK mark is appended to the clip.

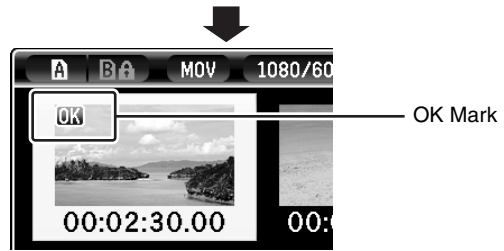
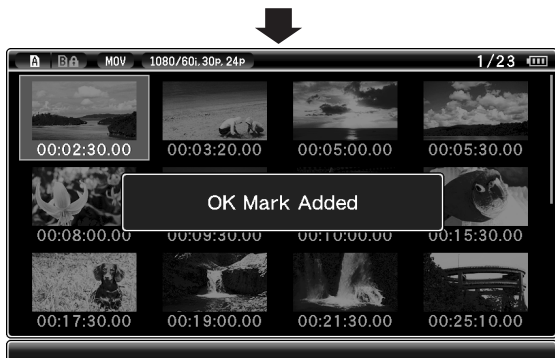

### Memo :

- The [USER1] button is disabled (displayed in gray) and OK marks cannot be appended when the write-protect switch of the SDHC card is set (a lock icon is displayed).
- "OK Mark Added..." is displayed when changing marks and other operations are unavailable.

### ■ During Playback or Pause Screen

1 Press [USER1] button during clip playback.

An OK mark is appended to the clip.

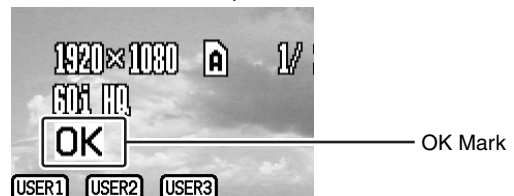

### Memo :

- The clip pauses when an OK mark is appended or deleted during playback.



## Deleting OK Marks

### ■ During Thumbnail Screen

1 Select a clip to delete OK mark and press the [USER1] button.

The OK mark is deleted.

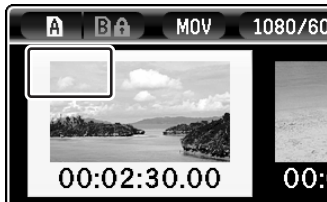
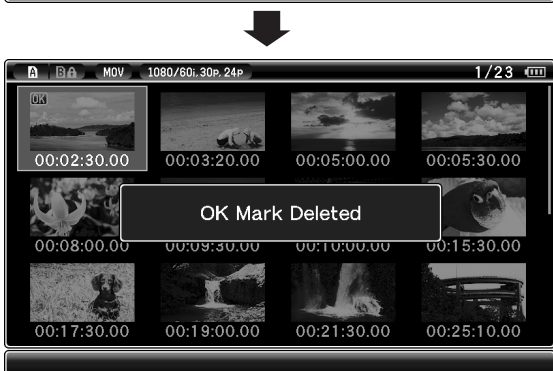

### ■ During Playback or Pause Screen

1 Press the [USER1] button when playing back a clip appended with OK mark.

The OK mark is deleted.

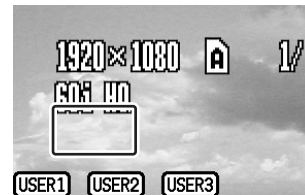

### Memo :

- The [USER1] button is disabled (displayed in gray) and OK marks cannot be deleted when the write-protect switch of the SDHC card is set ( is displayed).
- “OK Mark Added...”/“OK Mark Deleted...” is displayed when changing marks and other operations are unavailable.

# Menu Display and Detailed Settings

## Basic Operations in Menu Screen

Press the [MENU] button on the side control panel of the camera recorder to display the menu screen on the LCD monitor and viewfinder.

Various settings for shooting and playback can be configured on the menu screen.

There are two types of menu screens - [Main Menu] and [Favorites Menu].

[Main Menu] contains all the setting items of the camera recorder, classified according to functions and uses, while [Favorites Menu] allows users to customize the menu items freely. (☞ Page 98)

The operating procedures and main screen displays are the same for both menus.

The menu screen can also be displayed on external monitors connected to the video signal output terminal.

(☞ Page 92 [Analog Out Char.]

(☞ Page 92 [SDI Out Char.]

## Operation Buttons

Use the operation buttons on the side control panel of the camera recorder to operate the menu.

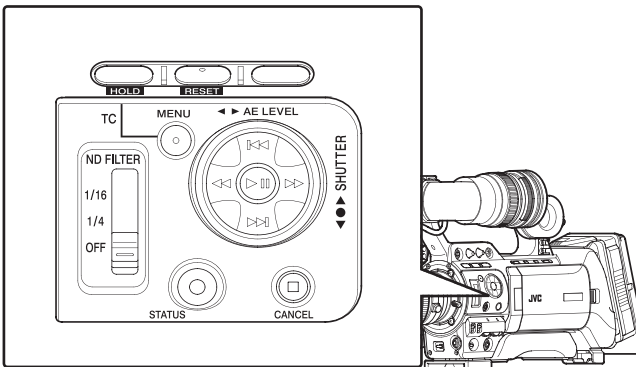

Name	Description
① [MENU] Button	Displays the menu screen. ([Main Menu] is displayed by default when pressed.) During normal usage, [Main Menu] is displayed if the previous menu operation ended at [Main Menu], and [Favorites Menu] if the previous menu operation ended at [Favorites Menu]. Press this button to close the menu screen during menu display and return to the normal screen.
② [USER1] Button	Adds the selected menu or submenu item to the [Favorites Menu]. (☞ Page 98)
③ [USER2] Button	Resets settings in the [TC Preset] or [UB Preset] setting screen. This button is disabled in other screens.
④ Set Button (●)	Sets the values and items.

Name	Description
⑤ Cross-shaped Button (▲▼◀▶)	▲ : Moves the cursor upward. ▼ : Moves the cursor downward. ◀ : Moves back to the previous item. ▶ : Moves forward to the next item.
⑥ [CANCEL] Button	Cancels settings and returns to the previous screen.
⑦ [STATUS] Button	Switches between the [Main Menu] and [Favorites Menu] screens.

## Display and Description of the Menu Screen

### Selecting Menu Items

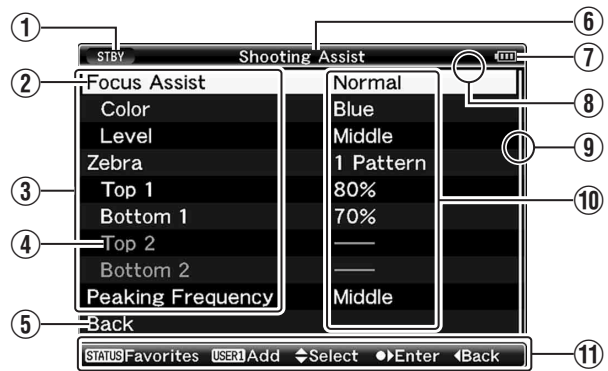

Name	Description
① Status Display	Recording, playback, etc. Displays the current status. Same display as the status screen. ■ During Camera mode : [STBY], [REC], etc. (☞ Page 102) ■ During Media mode (SD Card mode) : [PLAY], [STILL], etc. (☞ Page 109)
② Cursor	Indicates the selected item. Use the cross-shaped button (▲▼) to move the cursor.
③ Menu Item	Displays the names of the menu item and sub-menu. Menu items with [...] after them indicates that there is a sub-menu to access.
④ Fixed Item	Items that cannot be changed are displayed in gray and cannot be selected.
⑤ [Back] Back	Select [Back] and press the Set button (●) to return to the previous level.
⑥ Menu Title	Title of the currently displayed menu.
⑦ Remaining Battery Power	<ul style="list-style-type: none"> <li>▣ : Ample battery power.</li> <li>▣ : Slightly reduced battery power.</li> <li>▣ : Low battery power.</li> <li>▣ : Empty battery power. (Blinks in red)</li> <li>⚡ : External power supply connected.</li> </ul> <p><b>Memo :</b></p> <ul style="list-style-type: none"> <li>● If the battery in use is not a recommended one, the battery mark which indicates the battery level may not appear.</li> </ul>

Name	Description
⑧ Header	Indicates the current menu type with the line color. Blue : [Main Menu] Screen Green : [Favorites Menu] (Operation screen) Magenta : [Favorites Menu] (Editing screen)
⑨ Scroll Bar	Indicates the scroll position.
⑩ Setting Values	Setting values for the menu items. For menus with sub-menus, values are not displayed.
⑪ Operation Guide	Guide for the current operation buttons.

## ■ Changing Setting Values

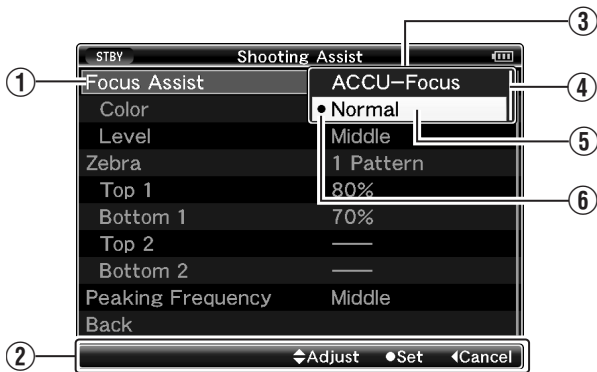

Name	Description
① Menu Item to Change	Menu item to be changed. A list of setting values ③ appears in a pop-up.
② Operation Guide	Guide for the current operation buttons.
③ List of Setting Values	A pop-up displaying a list of setting values for selection. The height of the pop-up depends on the number of settings available. Use the scroll bar ④ to confirm the current display status.
④ Scroll Bar	Indicates the scroll position.
⑤ Cursor	Indicates the selected item. Use the cross-shaped button (▲▼) to move the cursor.
⑥ Setting Values Before Change	Setting values before changing. ● appears at the beginning of the item.

## Text Input with Software Keyboard

Use the software keyboard to enter the [Scene File]/[Picture File] submenu and [Clip Name Prefix].

## ■ [Scene File]/[Picture File] (👉 Page 120)

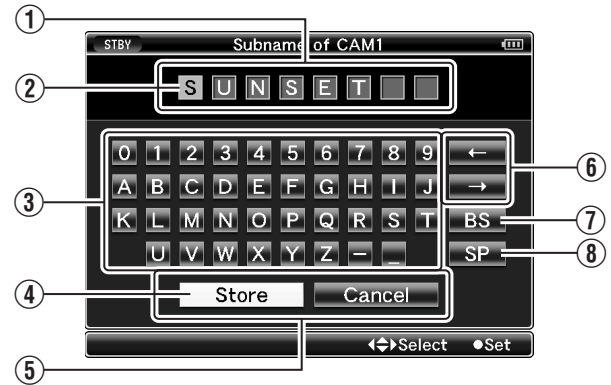

## ■ [Clip Name Prefix] (👉 Page 76)

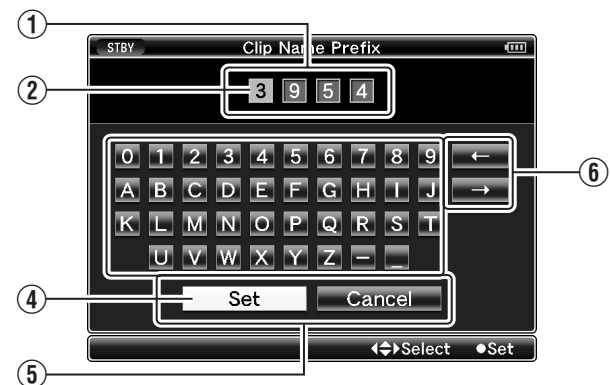

Name	Description
① Character Entry Field	Field for entering the title. You can enter up to 8 characters for the [Scene File]/[Picture File] submenu or up to 4 characters for the [Clip Name Prefix].
② Character Cursor	Select a character using the key cursor ④, and press the Set button (●) to input the selected character at the position of the character cursor. The character cursor moves to the next position on the right each time a character is input. The cursor can be moved using the arrow keys ⑥.
③ Character Keys	Use the cross-shaped button (▲▼▶◀) to move the key cursor ④ to the character you want to enter.
④ Key Cursor	Indicates the currently selected character or item. Use the cross-shaped button (▲▼▶◀) to move the cursor.
⑤ Confirmation Buttons	Select [Set]/[Store] and press the Set button (●) to confirm the title. Select [Cancel] and press the Set button (●) on the side control panel of the camera recorder to abort character input and return to the previous screen.
⑥ Arrow Keys	Moves the position of the character cursor ②.
⑦ [BS] Backspace Key	Select [BS] and press the Set button (●) on the side control panel of the camera recorder to delete the character on the left of the character cursor ②.
⑧ [SP] Space Key	Select [SP] and press the Set button (●) on the side control panel of the camera recorder to enter a space at the current position of the character cursor ②.

# Menu Screen Hierarchical Chart

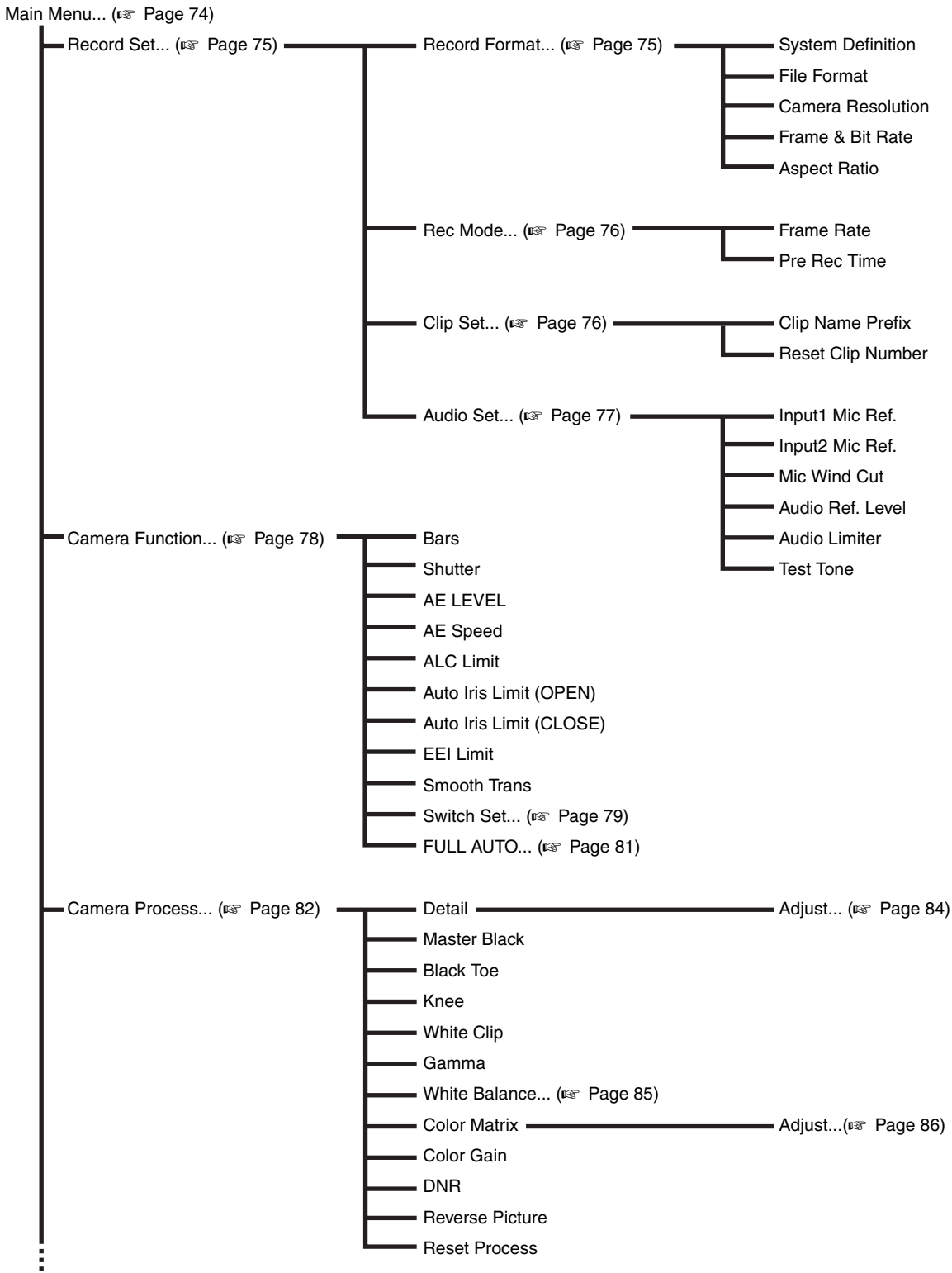

**Memo :**

- A [Back] item (omitted in the chart) can be found at the end of each menu item. Select [Back] and press the Set button (●) to return to the previous level.

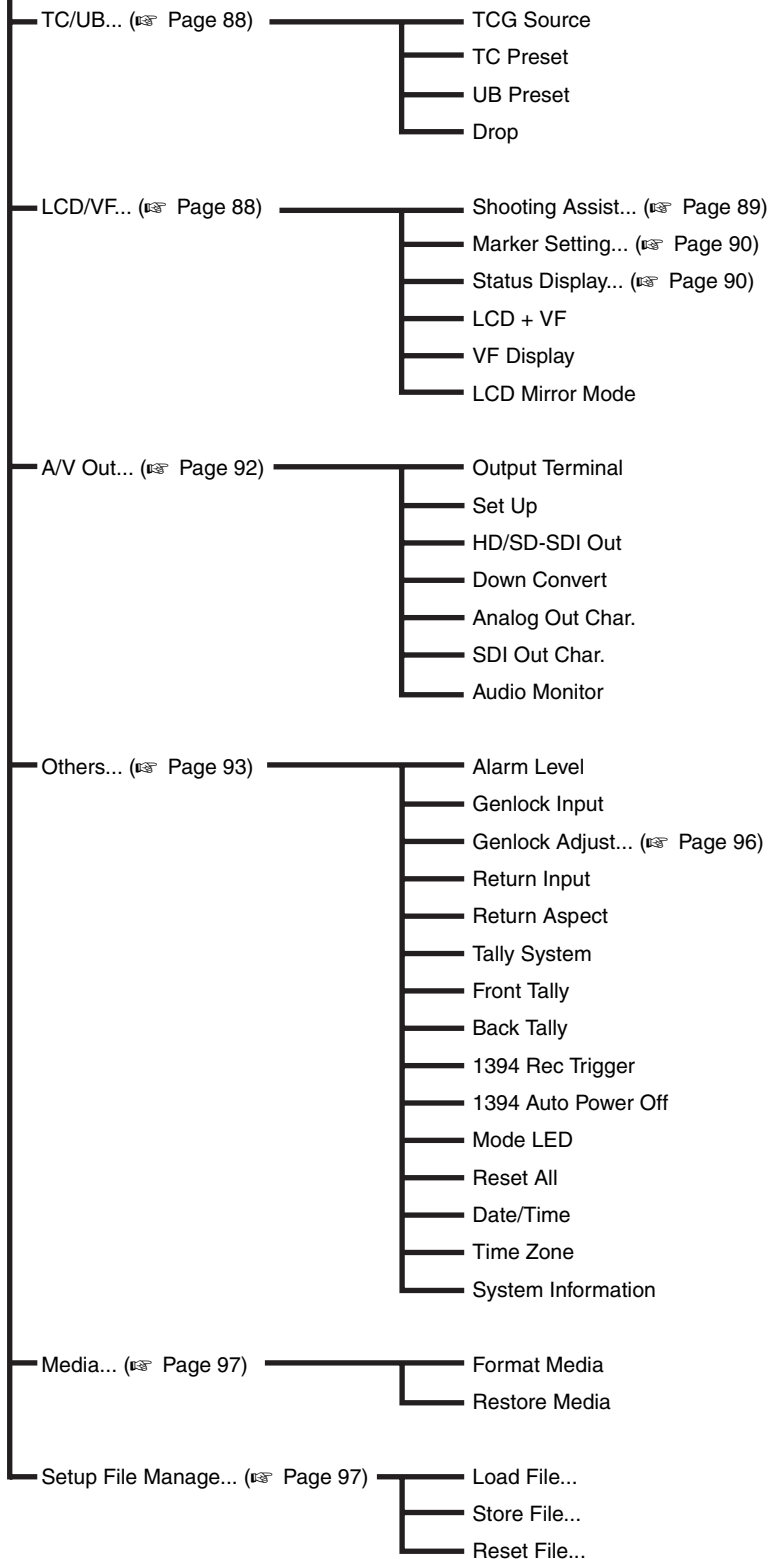

**Memo :**

- A [Back] item (omitted in the chart) can be found at the end of each menu item. Select [Back] and press the Set button (●) to return to the previous level.

### Main Menu Screen

Some menus cannot be set depending on the operating mode or status of the camera recorder. These items are displayed in gray, and they cannot be selected.

Item	Function
<b>Record Set...</b>	Menu screen for specifying video or audio settings during shooting and playback. The cursor does not move to this item during recording or in Media mode. (☞ Page 75)
<b>Camera Function...</b>	Menu screen for specifying operation settings during shooting. The cursor moves to this item only in Camera mode. (☞ Page 78)
<b>Camera Process...</b>	Menu screen for adjusting the quality of camera images. The cursor does not move to this item in the AUX and Media modes. (☞ Page 82)
<b>TC/UB...</b>	Menu screen for setting time code and user's bit. The cursor does not move to this item during recording. (☞ Page 88)
<b>LCD/VF...</b>	Item for specifying settings related to the LCD monitor or viewfinder screen. This menu screen can be used to specify settings related to the Focus Assist mode, zebra pattern display, screen size, marker, and safety zone. In addition, it is also used for selecting whether to display characters on the LCD monitor or viewfinder screen, as well as for adjusting the picture quality of the LCD monitor screen. The cursor does not move to this item in Media mode. (☞ Page 88)
<b>A/V Out...</b>	Item for specifying connection settings with external devices. (☞ Page 92)
<b>Others...</b>	Menu screen for specifying the settings of other functions. Use this item to adjust the alarm volume, front/back tally lamp settings, status indicator, 1394 input settings, genlock input and return video input settings, date/time, time zone, and other settings. It can also be used to reset the menu settings to their default values. (☞ Page 93)
<b>Media...</b>	Item for formatting or restoring the SDHC card. (☞ Page 97)
<b>Setup File Manage...</b>	Displays the [Setup File Manage] menu screen. Settings of the menu screen can be saved as a file on the camera recorder or an SDHC card, and the saved settings can be loaded when necessary. The cursor does not move to this item during recording or in Media mode. (☞ Page 97)
<b>Exit</b>	Select this item and press the Set button (●) to return to the normal screen.

# Record Set Menu

## Record Format Menu

After setting of all items in the [Record Format] menu is complete, select [Set] at the bottom of the screen to apply the new settings on the camera recorder and switch the record format. A "Please Wait" message appears during switching.

\* Default values are indicated in bold characters.

Item	Setting Values	Function
<b>System Definition</b>	<b>HD (MPEG2)</b> SD (DV)	For selecting a system definition. HD (MPEG2) : Records in HD (High Definition) quality. SD (DV) : Records in SD (Standard Definition) quality. <b>Note :</b> <ul style="list-style-type: none"> <li>The selectable options for the [File Format], [Camera Resolution], and [Frame &amp; Bit Rate] settings vary depending on the setting of this item.</li> <li>When the [GENLOCK/AUX] switch is set to "AUX", this item is fixed at "SD (DV)". (U model)</li> </ul>
<b>File Format</b>		For selecting the format of the file to be recorded to the SDHC card.
When [System Definition] is "HD (MPEG2)"	<b>QuickTime</b> MP4	
When [System Definition] is "SD (DV)"	<b>QuickTime</b> AVI	
<b>Camera Resolution</b>	<b>1920x1080</b> 1440x1080 1280x720 720 x 480 720 x 576	For setting the size of the recorded image when [System Definition] is set to "HD (MPEG2)". (Horizontal x vertical) <b>Memo :</b> <ul style="list-style-type: none"> <li>When [System Definition] is set to "SD (DV)", this item is fixed as follows for the different models. <ul style="list-style-type: none"> <li>U model : 720 x 480</li> <li>E model : 720 x 576</li> </ul> </li> <li>The selectable values of [Frame &amp; Bit Rate] vary according to the setting of this item.</li> </ul>
<b>Frame &amp; Bit Rate</b>		For setting the frame rate and encoding bit rate when [System Definition] is set to "HD (MPEG2)". Selection can be made from 19 combinations of frame rate (60p, 50p, 30p, 25p, 24p, 60i, 50i) and bit rate (HQ (35Mbps) VBR), (SP (25 Mbps/19 Mbps) CBR). <b>Memo :</b> <ul style="list-style-type: none"> <li>When [System Definition] is set to "SD (DV)", this item is fixed as follows for the different models. <ul style="list-style-type: none"> <li>U model : 60i</li> <li>E model : 50i</li> </ul> </li> <li>The selectable items vary according to the [File Format] and [Camera Resolution] settings.</li> </ul>
When [Camera Resolution] is "1280x720"	<b>60p (HQ) (U model),</b> 60p (SP), 30p (HQ), 30p (SP), <b>50p (HQ) (E model),</b> 50p (SP), 25p (HQ), 25p (SP), 24p (HQ), 24p (SP)	
When [Camera Resolution] is "1440x1080", and [File Format] is "QuickTime"	<b>60i (HQ) (U model),</b> 60i (SP), <b>50i (HQ) (E model),</b> 50i (SP)	
When [Camera Resolution] is "1440x1080", and [File Format] is "MP4"	<b>60i (SP) (U model),</b> <b>50i (SP) (E model)</b>	
When [Camera Resolution] is "1920x1080"	<b>60i (HQ) (U model),</b> 30p (HQ), <b>50i (HQ) (E model),</b> 25p (HQ), 24p (HQ)	
<b>Aspect Ratio</b>	<b>16:9</b> 4:3	For setting the aspect ratio of the recorded image when [System Definition] is set to "SD (DV)". <b>Memo :</b> <ul style="list-style-type: none"> <li>When [System Definition] is set to "HD (MPEG2)", this item is fixed at "16:9".</li> </ul>



# Record Set Menu (continued)

### Rec Mode Menu

Item	Setting Values	Function
<b>Rec Mode</b>	<b>Normal</b> Pre Rec Clip Continuous Variable Frame	For selecting the record mode for recording to the SDHC card. (☞ Page 58) <b>Memo :</b> <ul style="list-style-type: none"> <li>[Variable Frame] is selectable when [Camera Resolution] is set to "1280x720", and [Frame &amp; Bit Rate] is set to "30p (HQ)", "24p (HQ)", or "25p (HQ)".</li> </ul>
<b>Frame Rate</b>		For setting the recording [Frame Rate] when [Rec Mode] is set to [Variable Frame]. <b>Memo :</b> <ul style="list-style-type: none"> <li>When [AE LEVEL] in the [Main Menu] → [Camera Function] → [Switch Set] menu is set to "AE LEVEL/VFR", you can use the cross-shaped button (◀▶) to select the frame rate during Variable Frame Rec. In modes other than Variable Frame Rec, the cross-shaped button (◀▶) functions as the [AE LEVEL] setting button. (☞ Page 80)</li> <li>When [Frame Rate] is changed and the shutter speed becomes a value that is invalid for the current [Frame Rate], the shutter speed is automatically changed to match the current [Frame Rate].</li> </ul>
When [Frame & Bit Rate] is "30p (HQ)"	60, 48, 40, <b>30</b> , 24, 20, 15, 12, 10	
When [Frame & Bit Rate] is "24p (HQ)"	60, 48, 40, 30, <b>24</b> , 20, 15, 12, 10	
When [Frame & Bit Rate] is "25p (HQ)"	50, 40, <b>25</b> , 20, 15, 12.5, 10	
<b>Pre Rec Time</b>	<b>5sec</b> , 10sec, 20sec	For setting the pre-recording time when [Rec Mode] is set to "Pre Rec".

### Clip Set Menu

\* Default values are indicated in bold characters.

Item	Setting Values	Function
<b>Clip Name Prefix</b>	<b>xxxG</b> (The default value of xxx is the last three digits of the serial number.)	For setting the first four characters of the name of the clip file to be recorded to the SDHC card. Enter any of the 38 characters including alphabets (upper case), numbers (0 to 9), "_" (underscore), and "-" (hyphen) using the software keyboard. (☞ Page 71 [Text Input with Software Keyboard])
<b>Reset Clip Number</b>	—	For assigning a new number to (Clip Number) by resetting it (0001). Select [Reset] and press the Set button (●) to reset the number. When other clips exist on the SDHC card, the smallest available number is used after reset. Example: If the [Clip Name Prefix] is "ABCD", and "ABCD0001" already exists on the SDHC card, "ABCD0002" will be assigned.

## Audio Set Menu

Item	Setting Values	Function
<b>Input1 Mic Ref.</b>	-50dB <b>-60dB</b>	For setting the reference input level when the [AUDIO INPUT1] button is set to "MIC" or "MIC+48V". -50dB : Sets -50 dB as the reference value. -60dB : Sets -60 dB as the reference value.
<b>Input2 Mic Ref.</b>	-50dB <b>-60dB</b>	For setting the reference input level when the [AUDIO INPUT2] button is set to "MIC" or "MIC+48V". -50dB : Sets -50 dB as the reference value. -60dB : Sets -60 dB as the reference value.
<b>Mic Wind Cut</b>	Both Input2 Input1 <b>Off</b>	For selecting whether to cut the low frequencies of the audio input signals (low-cut) when the [AUDIO INPUT 1/2] button is set to "MIC" or "MIC+48V". Set this item to reduce wind noise from the microphone. Both : Enables low-cut on both the [INPUT1] and [INPUT2] terminals. Input2 : Enables low-cut on the audio of the [INPUT2] terminal only. Input1 : Enables low-cut on the audio of the [INPUT1] terminal only. Off : Disables low-cut.
<b>Audio Ref. Level</b>	-12dB <b>-20dB</b>	For setting the audio reference level to be recorded to the SDHC card. (Applies to both [CH1/CH2].) -20dB : Outputs signals of the reference level when the meter is at -20 dBFS. -12dB : Outputs signals of the reference level when the meter is at -12 dBFS.
<b>Audio Limiter</b>	<b>On</b> Off	For specifying whether to trigger the limiter when the [AUDIO SELECT CH-1/CH-2] switch is set to "MANUAL". On : Triggers the limiter when excessive audio signals are input, and compresses the recording level. Off : Does not trigger limiter.
<b>Test Tone</b>	On <b>Off</b>	For specifying whether to output the audio test signals (1 kHz) during color bar output. On : Audio test signals are output. Off : Audio test signals are not output.

# Camera Function Menu

\* Default values are indicated in bold characters.

Item	Setting Values	Function
<b>Bars</b>	On <b>Off</b>	For setting whether to output color bars. On : Color bars are output. Off : Color bars are not output. <b>Memo :</b> • When the [FULL AUTO] switch on the camera recorder is set to “ON”, and [Bars] in the [FULL AUTO] menu is set to “Off”, this item is set to “Off” automatically. (Page 81)
<b>Shutter</b>	EEl Variable <b>Step</b>	For specifying shutter-related settings. Use this item to set to “Step” (fixed value) or “Variable” when operating with the cross-shaped button (▲▼) on the right of the camera recorder. During automatic control, this is set to “EEl”. EEl : Sets to automatic control. Variable : Sets to variable scan. Use this setting such as when shooting a PC monitor. Step : Sets to step shutter, which switches the shutter speed by a fixed value.
<b>AE LEVEL</b>	+3 to +1, <b>Normal</b> , -1 to -3	For setting the convergence level during AE (Auto Exposure). This can also be adjusted using the cross-shaped button (◀▶) on the right of the camera recorder.
<b>AE Speed</b>	<b>Fast</b> Middle Slow	For setting the convergence speed during AE (Auto Exposure).
<b>ALC Limit</b>	<b>18dB</b> 12dB 6dB	For setting the maximum gain value of “ALC”, which electrically boosts the sensitivity level according to the brightness automatically. 18dB : Sets the maximum ALC gain value to +18 dB. 12dB : Sets the maximum ALC gain value to +12 dB. 6dB : Sets the maximum ALC gain value to +6 dB.
<b>Auto Iris Limit (OPEN)</b>	F5.6, F4, F2.8, F2, <b>F1.6</b> , F1.4	For setting the limit value of the OPEN end when auto iris is enabled.
<b>Auto Iris Limit (CLOSE)</b>	F16, <b>F11</b> , F8, F5.6,	For setting the limit value of the CLOSE end when auto iris is enabled.
<b>EEl Limit</b>	4F-stop <b>3F-stop</b> 2F-stop	For setting the shutter speed control range when EEl is enabled. 4F-stop : Moves iris control by 4 f/stops in EEl. 3F-stop : Moves iris control by 3 f/stops in EEl. 2F-stop : Moves iris control by 2 f/stops in EEl.
<b>Smooth Trans</b>	Fast Middle Slow <b>Off</b>	For setting the shock reduction function, which slows down the sudden change when switching with the [GAIN] or [WHT.BAL.] selection switch. However, this function is disabled when the [FULL AUTO] switch of the camera recorder is set to “ON”, or when switching the gain selection switch while “ALC” is set. Fast : Runs the Smooth Trans function at high speed. Middle : Runs the Smooth Trans function at medium speed. Slow : Runs the Smooth Trans function at low speed. Off : Deactivates the Smooth Trans function.
<b>Switch Set...</b>	For specifying the switch settings of the camera recorder. (Page 79)	
<b>FULL AUTO...</b>	For specifying settings when the [FULL AUTO] switch of the camera recorder is set to “ON”. (Page 81)	

## Switch Set Item

\* Default values are indicated in bold characters.

Item	Setting Values	Function												
<b>FAW</b>	<b>None</b> PRESET A B	For assigning the FAW (Fulltime Auto White Balance) function to a position on the [WHT.BAL.] selection switch. This is fixed at "FAW" when the [FULL AUTO] switch of the camera recorder is set to "ON". None : FAW function is not assigned. PRESET : Assigns FAW to the PRESET position. A : Assigns FAW to the A position. B : Assigns FAW to the B position.												
<b>GAIN L</b> <b>GAIN M</b> <b>GAIN H</b>	ALC, 18dB, 15dB, 12dB, 9dB, 6dB, 3dB, 0dB	For setting the gain value of each position on the [GAIN] selection switch. This is fixed at "ALC" when the [FULL AUTO] switch of the camera recorder is set to "ON". <b>(Default values GAIN L: 0dB, GAIN M: 9dB, GAIN H: 18dB)</b>												
<b>USER1</b> <b>USER2</b> <b>USER3</b>	By assigning one of the following functions to each of the [USER1]/[USER2]/[USER3] buttons, these buttons can be used to control the assigned function (on/off, start, switch). Set according to the shooting conditions. Functions can be assigned only in Camera mode (except AUX mode). <b>(Default values USER1: Bars, USER2: B.Stretch3, USER3: Load File)</b>	<table border="1"> <thead> <tr> <th>Setting Values</th> <th>Description</th> </tr> </thead> <tbody> <tr> <td>None</td> <td>No function is assigned.</td> </tr> <tr> <td>Bars</td> <td>Assigns the function of [Bars] in the [Camera Function] menu. (☞ Page 78)</td> </tr> <tr> <td>Load File</td> <td>Assigns the function of [Load File] in the [Setup File Manage] menu. (☞ Page 97)</td> </tr> <tr> <td>Clip Review</td> <td>Assigns the Clip Review function. (☞ Page 56)</td> </tr> <tr> <td>B.Stretch1 B.Stretch2 B.Stretch3 B.Stretch4 B.Stretch5 B.Compress1 B.Compress2 B.Compress3 B.Compress4 B.Compress5</td> <td>Assigns the functions of [Stretch Level] and [Compress Level] under [Black Toe] in the [Camera Process] menu. (☞ Page 82)</td> </tr> </tbody> </table>	Setting Values	Description	None	No function is assigned.	Bars	Assigns the function of [Bars] in the [Camera Function] menu. (☞ Page 78)	Load File	Assigns the function of [Load File] in the [Setup File Manage] menu. (☞ Page 97)	Clip Review	Assigns the Clip Review function. (☞ Page 56)	B.Stretch1 B.Stretch2 B.Stretch3 B.Stretch4 B.Stretch5 B.Compress1 B.Compress2 B.Compress3 B.Compress4 B.Compress5	Assigns the functions of [Stretch Level] and [Compress Level] under [Black Toe] in the [Camera Process] menu. (☞ Page 82)
Setting Values	Description													
None	No function is assigned.													
Bars	Assigns the function of [Bars] in the [Camera Function] menu. (☞ Page 78)													
Load File	Assigns the function of [Load File] in the [Setup File Manage] menu. (☞ Page 97)													
Clip Review	Assigns the Clip Review function. (☞ Page 56)													
B.Stretch1 B.Stretch2 B.Stretch3 B.Stretch4 B.Stretch5 B.Compress1 B.Compress2 B.Compress3 B.Compress4 B.Compress5	Assigns the functions of [Stretch Level] and [Compress Level] under [Black Toe] in the [Camera Process] menu. (☞ Page 82)													
<b>LENS RET</b>	<b>Clip Review</b> OK Mark Focus Assist Return	For assigning a function to the [RET] button on the lens. This function does not work if the [RET] button is not available on the lens in use. Clip Review : Assigns the Clip Review function to the [RET] button. (☞ Page 56) OK Mark : Assigns the OK mark function to the [RET] button. This function operates during shooting. (☞ Page 58) Focus Assist : Assigns the Focus Assist function to the [RET] button. (☞ Page 37) Return : Assigns the return video display function to the [RET] button. (☞ Page 128)												
<b>Clip Review</b>	<b>Last 5 sec</b> Top 5 sec CLIP	For specifying the operation when [LENS RET] is set to "Clip Review". Last 5 sec : Views about 5 seconds of the clip from the ending. Top 5 sec : Views about 5 seconds of the clip from the beginning. CLIP : Views the entire clip. <b>Memo :</b> ● Selectable when [LENS RET] is set to "Clip Review", or when any of the [USER1]/[USER2]/[USER3] buttons is set to "Clip Review".												

### Camera Function Menu (continued)

\* Default values are indicated in bold characters.

Item	Setting Values	Function
<b>SKIN A./SPOT M.</b>	<b>Skin Area</b>	For assigning the function of the [SKIN AREA/SPOT METER] switch on the camera recorder. Skin Area : Assigns the Skin Detail function and its area display. Spot Meter : Assigns the Spot Meter display function. <b>Memo:</b> <ul style="list-style-type: none"> <li>When "Skin Area" is selected, [Skin Detect] is forcibly set to "On" when the [SKIN AREA/SPOT METER] switch is flipped, even if [Skin Detect] is set to "Off". Alternatively, you can set [Skin Detect] to "Off", and turn the Skin Detail function On/Off by flipping the lever whenever necessary. (Page 84)</li> </ul>
	Spot Meter	
<b>SPOT METER</b>	<b>Max&amp;Min</b>	For specifying the operation of [Spot Meter]. (Page 55) Max&Min : Displays the brightest and darkest areas of the image. Min : Displays the darkest area of the image. Max : Displays the brightest area of the image. Manual : Displays the image brightness at a specified position. <b>Memo:</b> <ul style="list-style-type: none"> <li>This item is selectable when [SKIN A./SPOT M.] is set to "Spot Meter". When "Skin Area" is set, this item appears as "---" and cannot be selected.</li> <li>Positions are detected automatically when this item is set to "Max&amp;Min", "Min", or "Max". When set to "Manual", it functions in a fixed position.</li> </ul>
	Min	
	Max	
	Manual	
<b>AE LEVEL</b>	<b>AE LEVEL/VFR</b>	For specifying the operation of the cross-shaped button (◀▶) on the right of the camera recorder. AE LEVEL/VFR: Sets the number of frames during Variable Frame Rec, and operates as the AE LEVEL setting button in other cases. (Page 60) AE LEVEL : Operates as the AE LEVEL setting button at all times. Disable : Disables the button.
	<b>AE LEVEL</b>	
	Disable	

## FULL AUTO Item

This is used to set specific functions to the auto mode when the [FULL AUTO] switch of the camera recorder is set to "ON".

Item	Setting Values	Function
<b>Gain</b>	SW Set <b>ALC</b>	SW Set : Sets gain according to the [GAIN] selection switch. ALC : Sets gain to the "ALC" (forced auto) mode. <b>Memo:</b> <ul style="list-style-type: none"> <li>When the remote control unit comes with an FAS function, this is fixed at "ALC" and cannot be selected. (☞ Page 131)</li> </ul>
<b>Iris Control</b>	Off <b>Auto</b>	Off : Iris control is not performed. Auto : Sets iris control to the forced auto mode. <b>Memo:</b> <ul style="list-style-type: none"> <li>When the remote control unit comes with an FAS function, this is fixed at "Auto" and cannot be selected. (☞ Page 131)</li> <li>When the iris mode switch of the lens is set to "A" (auto), the iris is fixed at the point of time when this item is switched from "Auto" to "Off".</li> </ul>
<b>Shutter</b>	SW Set <b>EEl</b>	SW Set : Sets shutter according to the switch. EEl : Sets shutter to the forced auto mode. <b>Memo:</b> <ul style="list-style-type: none"> <li>When the remote control unit comes with an FAS function, this is fixed at "EEl" and cannot be selected. (☞ Page 131)</li> </ul>
<b>White Balance</b>	SW Set <b>FAW</b>	SW Set : Sets white balance according to the [WHT.BAL.] selection switch. FAW : Sets white balance to the forced auto mode. <b>Memo:</b> <ul style="list-style-type: none"> <li>When the remote control unit comes with an FAS function, this is fixed at "FAW" and cannot be selected. (☞ Page 131)</li> </ul>
<b>Bars</b>	Menu Set <b>Off</b>	Menu Set : Sets color bar output according to the menu settings (via switch operation). Off : Sets color bar output to the forced Off mode. <b>Memo:</b> <ul style="list-style-type: none"> <li>When the remote control unit comes with an FAS function, this is fixed at "Off" and cannot be selected. (☞ Page 131)</li> </ul>
<b>Audio</b>	SW Set <b>Auto</b>	SW Set : Sets the audio recording level according to the switch. Auto : Sets the audio recording level to the forced auto mode.

## Menu Display and Detailed Settings

# Camera Process Menu

\* Default values are indicated in bold characters.

Item	Setting Values	Function
<b>Detail</b>	Max, 9 to 1, <b>Normal</b> , -1 to -9, Min, Off	For adjusting the contour (detail) enhancement level. Increase the number : Sharpens the contour. Decrease the number : Softens the contour. Off : Disables this function.
<b>Adjust...</b>	For specifying the detailed settings of the contour (detail). (Page 84) <b>Memo</b> : ● This item cannot be selected when [Detail] is set to "Off".	
<b>Master Black</b>	Max, 9 to 1, <b>Normal</b> , -1 to -9, Min	For adjusting the pedestal level (master black) that serves as the reference black. Increase the number : Raises the pedestal level. Decrease the number : Lowers the pedestal level.
<b>Black Toe</b>	Compress Stretch <b>Normal</b>	For altering the gain of dark areas. Adjust this item according to the condition of the captured video signals. Compress : Compresses the gain of dark areas to increase the contrast when the entire image appears bright and contrast is weak. Specify the compression amount with [Compress Level]. Stretch : Increases the gain of dark areas in an image to stretch the signals of these areas only, thereby showing the contrast between bright and dark areas more clearly. Specify the stretch amount with Stretch Level. Normal : Normal condition.
<b>Stretch Level</b>	Level 5 Level 4 <b>Level 3</b> Level 2	Stretch amount increases when a larger value is specified. <b>Memo</b> : ● This item is displayed only when [Black Toe] is set to "Stretch". Otherwise, this item appears as "---" and cannot be selected.
<b>Compress Level</b>	Level 1	Compression amount increases when a larger value is specified. <b>Memo</b> : ● This item is displayed only when [Black Toe] is set to "Compress". Otherwise, this item appears as "---" and cannot be selected.
<b>Point Level</b>	15% to 11% <b>10%</b> , 9% to 5%	For specifying the luminance point at which the dark area is to be stretched or compressed. <b>Memo</b> : ● When [Black Toe] is set to "Normal", this item appears as "---" and cannot be selected.
<b>Knee</b>	Manual <b>Auto</b>	For specifying the "Knee" operation, which compresses video signals beyond a certain level to show the gradation of the highlighted portion. To check the gradation of a bright area, set to "Manual" and adjust the knee point manually. Manual : Enables manual adjustment of the knee point (starting point of knee operation) using "Level". Auto : Adjusts the knee point (starting point of knee operation) automatically according to the luminance level.
<b>Level</b>	<b>100%</b> 95%, 90%, 85%, 80%, 75%, 70%	For setting the starting point of knee compression (knee point). Increase the number : Increases the knee point level. Decrease the number : Decreases the knee point level. <b>Memo</b> : ● When [Knee] is set to "Auto", this item appears as "---" and cannot be selected.
<b>Sensitivity</b>	<b>Fast</b> Middle Slow	For setting the response speed of the "Knee" operation when [Knee] is set to "Auto". Set to "Slow" when shooting an object under a condition where there is drastic change in the light intensity. <b>Memo</b> : ● When [Knee] is set to "Manual", this item appears as "---" and cannot be selected.



\* Default values are indicated in bold characters.

Item	Setting Values	Function
<b>White Clip</b>	100% <b>108%</b>	For setting the point to apply white clip for input video signals with a high luminance level. 100% : Applies white clip at the point where the luminance level is 100 %. Even when this item is set to "108%", it switches automatically to "100%" if the screen appears too white. Set to this value when the system in use limits Y output signals within 100 %. 108% : Applies white clip at the point where the luminance level is 108 %.
<b>Gamma</b>	Film Out Cinema <b>Standard</b> Off	For adjusting the gamma curve that determines the gradation expression. Film Out : Sets to a gamma curve that focuses on the gradation expression of dark areas in order to ease post-processing of movie film output. Cinema : Sets to a gamma curve with similar gradation to the screen characteristics of movies. Standard : Sets to a standard gamma curve. Off : Disables gamma curve adjustment.
<b>Master Level</b>	Max, 4 to1, <b>Normal</b> , -1 to -4, Min	This item can be specified separately when [Gamma] is set to "Standard", "Cinema", or "Film Out". Increase the number : Enhances the gradation of black. However, the gradation of bright areas deteriorates. Decrease the number : Enhances the gradation of bright areas. However, the gradation of black deteriorates. <b>Memo:</b> ● When [Gamma] is set to "Off", this item appears as "---" and cannot be selected.
<b>R Level</b>	Max, 4 to1,	Gamma curves can be adjusted for each of R, G, and B. Use this to adjust to a color tone that cannot be expressed by the [Color Matrix] setting. <b>Memo:</b> ● When [Gamma] is set to "Off", this item appears as "---" and cannot be selected.
<b>G Level</b>	<b>Normal</b> ,	
<b>B Level</b>	-1 to -4, Min	
<b>White Balance...</b>	Menu for adjusting white balance. (☞ Page 85)	
<b>Color Matrix</b>	Cinema Subdued Cinema Vivid <b>Standard</b> Off	For setting the color matrix. Cinema Subdued : Sets to a subdued color matrix that is similar to the screen characteristics of movies. Cinema Vivid : Sets to a vivid color matrix that is similar to the screen characteristics of movies. Standard : Sets to a standard color matrix. Off : Sets the color matrix function to Off.
<b>Adjust...</b>	This item is used to adjust [Color Matrix] to a color according to the user's preference. This item cannot be selected when [Color Matrix] is set to "Off". (☞ Page 86)	
<b>Color Gain</b>	Off, Min, -1 to -9, <b>Normal</b> 9 to 1, Max	For adjusting the video signal color level. Off : Sets the video to black-and-white. Increase the number : Makes the colors more dense. Decrease the number : Makes the colors less dense. <b>Memo:</b> ● Images are displayed in black-and-white when this is set to "Off".
<b>DNR</b>	On <b>Off</b>	For setting the DNR (Digital Noise Reduction) function. The S/N ratio of the video can be enhanced by setting [DNR] to "On". On : Enables noise reduction. Off : Disables noise reduction. <b>Memo:</b> ● A retained image may appear when this is set to "On".
<b>Reverse Picture</b>	Rotate <b>Off</b>	For recording images correctly by reversing the image horizontally or vertically (Rotate) when the lens image appears upside down or laterally inverted. Rotate : Enables horizontal/vertical inversion of the image. Off : Disables horizontal/vertical inversion of the image.
<b>Reset Process</b>	—	Restores all items in the [Camera Process] menu to their default settings.

## Camera Process Menu (continued)

### Detail/Adjust... Item

\* Default values are indicated in bold characters.

Item	Setting Values	Function
<b>V/H Balance</b>	H-Max, 4 to 1, <b>Normal</b> , -1 to -4, H-Min	For setting the H/V balance to enhance contour (detail) in the horizontal (H) or vertical (V) direction. Increase the number : Enhances contour in the horizontal direction. Decrease the number : Enhances contour in the vertical direction.
<b>H Frequency</b>	High <b>Middle</b> Low	For specifying the correction frequency of the horizontal contour. Set this according to the object. High : Emphasizes the high frequency range. Use this when shooting objects with fine patterns. Middle : Emphasizes the intermediate frequency range. Low : Emphasizes the low frequency range. Use this when shooting objects with large patterns.
<b>V Frequency</b>	<b>High</b> Low	For specifying the correction frequency of the vertical contour. Set this according to the object. Low : Emphasizes the low frequency range. High : Emphasizes the high frequency range. <b>Memo :</b> • This item can only be selected when [Camera Resolution] of [Record Format] in the [Record Set] menu is set to "1280x720". (☞ Page 75)
<b>Skin Detect</b>	On <b>Off</b>	For turning On/Off the Skin Detail function, which is used to adjust the contour correction effect of the colors captured by the [Skin Color Adjust] menu. On : Enables the Skin Detail function. (Softens the detail at areas where skin tone is detected.) Off : Disables the Skin Detail function. <b>Memo :</b> • Even if [Skin Detect] is set to "Off", [Skin Detect] is forcibly set to "On" when the [SKIN AREA/SPOT METER] switch is flipped. Alternatively, you can set [Skin Detect] to "Off", and turn the Skin Detail function On/Off by flipping the lever whenever necessary.
<b>Level</b>	-3 -2 -1	For setting the level of contour correction (degree of softening) using the Skin Detail function. -3 : High level of contour correction (degree of softening) -2 : Medium level of contour correction (degree of softening) -1 : Low level of contour correction (degree of softening)
<b>Skin Color Adjust...</b>	For setting the Skin Detail function. (☞ Page 114)	
<b>Skin Color Detect</b>	Execute <b>Stop</b>	For capturing the skin color. Execute : Captures the color that triggers the Skin Detail function. Stop : Disables capturing of the color that triggers the Skin Detail function.
<b>Skin Color Range</b>	Wide, 9 to 1, <b>Normal</b> , -1 to -9, Narrow	For adjusting the range of skin tone to trigger the Skin Detail function. Adjust accordingly while checking the color range visually. Increase the number : Widens the range. Decrease the number : Narrows the range. <b>Memo :</b> • When [Color Gain] in the [Camera Process] menu is set to "Off", only the area where Skin Detail is functioning is displayed in skin tone. (☞ Page 83)

## White Balance Item

\* Default values are indicated in bold characters.

Item	Setting Values	Function
<b>Preset Temp.</b>	2800K, <b>3200K</b> , 3400K, 4200K, 4800K, 5200K, 5600K, 6500K, 7500K	For setting the color temperature when the [WHT.BAL.] selection switch of the camera recorder is set to "PRESET".
<b>Alternative Temp.</b>	2800K, 3200K, 3400K, 4200K, 4800K, 5200K, <b>5600K</b> , 6500K, 7500K	For setting the alternative color temperature in the Preset mode. When the [WHT.BAL.] switch of the camera recorder is set to "PRESET", pressing the [AWB] button each time switches the color temperature setting in the Preset mode. ([Preset Temp.] ↔ [Alternative Temp.] )
<b>White Paint R</b>	Max, 30 to 1, <b>Normal</b> , -1 to -31, Min	For adjusting the R (red) component in the AWB (Auto White Balance) mode. Increase the number : Strengthens the red. Decrease the number : Weakens the red. <b>Memo :</b> <ul style="list-style-type: none"> <li>• This item is selectable when the [WHT.BAL.] selection switch on the right of the camera recorder is set to "A" or "B". When "PRESET" is set, this item appears as "---" and cannot be selected.</li> <li>• Different values can be specified for "A" and "B".</li> <li>• After the [AWB] (Auto White Balance) button is pressed to readjust the white balance while [Clear Paint After AWB] set to "On", [White Paint R] switches automatically to "Normal".</li> </ul>
<b>White Paint B</b>	Max, 30 to 1, <b>Normal</b> , -1 to -31, Min	For adjusting the B (blue) component in the AWB (Auto White Balance) mode. Increase the number : Strengthens the blue. Decrease the number : Weakens the blue. <b>Memo :</b> <ul style="list-style-type: none"> <li>• This item is selectable when the [WHT.BAL.] selection switch on the right of the camera recorder is set to "A" or "B". When "PRESET" is set, this item appears as "---" and cannot be selected.</li> <li>• Different values can be specified for "A" and "B".</li> <li>• After the [AWB] (Auto White Balance) button is pressed to readjust the white balance while [Clear Paint After AWB] set to "On", [White Paint B] switches automatically to "Normal".</li> </ul>
<b>Clear Paint After AWB</b>	<b>On</b> Off	For specifying whether to clear the [White Paint R]/[White Paint B] settings after executing AWB (Auto White Balance). On : [White Paint R]/[White Paint B] are set to "Normal" after executing AWB. Off : [White Paint R]/[White Paint B] are not changed after executing AWB.
<b>Shading Mode</b>	Manual <b>Preset</b>	For specifying white shading adjustment settings. (☞ Page 44) Preset : Sets white shading adjustment to a fixed level. Manual adjustment is disabled. Manual : Enables manual white shading adjustment.
<b>Adjust...</b>	For making white shading adjustments. <b>Memo :</b> <ul style="list-style-type: none"> <li>• This item cannot be selected when [Shading Mode] is set to "Preset".</li> </ul>	

# Camera Process Menu (continued)

### Shading Mode/Adjust Item

\* Default values are indicated in bold characters.

- This item is selectable only when [Shading Mode] is set to “Manual”. [R Level], [G Level], and [B Level] cannot be selected when this is set to “Preset”.
- The screen switches to a color display, and the displays for Bars, Zebra and the Focus Assist mode are temporarily set to “OFF”, while the “B & W” mode in the [VF Display] menu temporarily switches to “Color”.

Item	Setting Values	Function
<b>R Level</b>	Max, 126 to 1, <b>Normal</b> , -1 to -127, Min	For adjusting the red level of white shading when [Shading Mode] is set to “Manual”. Increase the number : Decreases the red level at the bottom of the screen, and increases the red level at the top of the screen. Decrease the number : Decreases the red level at the top of the screen, and increases the red level at the bottom of the screen.
<b>G Level</b>	Max, 126 to 1, <b>Normal</b> , -1 to -127, Min	For adjusting the green level of white shading when [Shading Mode] is set to “Manual”. Increase the number : Decreases the green level at the bottom of the screen, and increases the green level at the top of the screen. Decrease the number : Decreases the green level at the top of the screen, and increases the green level at the bottom of the screen.
<b>B Level</b>	Max, 126 to 1, <b>Normal</b> , -1 to -127, Min	For adjusting the blue level of white shading when [Shading Mode] is set to “Manual”. Increase the number : Decreases the blue level at the bottom of the screen, and increases the blue level at the top of the screen. Decrease the number : Decreases the blue level at the top of the screen, and increases the blue level at the bottom of the screen.

### Color Matrix/Adjust Item

This item is used to adjust [Color Matrix] to a color according to the user's preference.

The adjusted values of “Standard”, “Cinema Vivid”, and “Cinema Subdued” in [Color Matrix] can be stored individually.

(☞ Page 83)

Item	Setting Values	Function
<b>Mg&amp;R Mg Level</b>	Max, 19 to 1, <b>Normal</b> , -1 to -19, Min	For adjusting the magenta/red level of the video toward magenta. Increase the number : Enhances the magenta component of magenta/red. Decrease the number : Reduces the magenta component of magenta/red.
<b>Mg&amp;R R Level</b>		For adjusting the magenta/red level of the video toward red. Increase the number : Enhances the red component of magenta/red. Decrease the number : Reduces the red component of magenta/red.
<b>R&amp;YI R Level</b>		For adjusting the red/yellow level of the video toward red. Increase the number : Enhances the red component of red/yellow. Decrease the number : Reduces the red component of red/yellow.
<b>R&amp;YI YI Level</b>		For adjusting the red/yellow level of the video toward yellow. Increase the number : Enhances the yellow component of red/yellow. Decrease the number : Reduces the yellow component of red/yellow.
<b>YI&amp;G YI Level</b>		For adjusting the yellow/green level of the video toward yellow. Increase the number : Enhances the green component of yellow/green. Decrease the number : Reduces the yellow component of yellow/green.
<b>YI&amp;G G Level</b>		For adjusting the yellow/green level of the video toward green. Increase the number : Enhances the green component of yellow/green. Decrease the number : Reduces the green component of yellow/green.
<b>YI&amp;G Mask Range</b>	Max, 19 to 11, <b>10</b> , 9 to 1, Min	For adjusting the extent of effect on the skin tone (color near the I-axis) when [YI&G YI Level] and [YI&G G Level] are adjusted. Increase the number : Reduces the effect on the skin tone. Decrease the number : Increases the effect on the skin tone. <b>Memo :</b> <ul style="list-style-type: none"> <li>• When green is enhanced in the + direction with [YI&amp;G G Level], increasing the [YI&amp;G Mask Range] value helps to prevent the skin tone from becoming greenish.</li> <li>• When [YI&amp;G YI Level] and [YI&amp;G G Level] are set to “Normal”, no changes will be observed on the screen when the [YI&amp;G Mask Range] value is changed.</li> </ul>

\* Default values are indicated in bold characters.

Item	Setting Values	Function
<b>G&amp;Cy G Level</b>	Max, 19 to 1, <b>Normal</b> , -1 to -19, Min	For adjusting the green/cyan level of the video toward green. Increase the number : Enhances the green component of green/cyan. Decrease the number : Reduces the green component of green/cyan.
<b>G&amp;Cy Cy Level</b>		For adjusting the green/cyan level of the video toward cyan. Increase the number : Enhances the cyan component of green/cyan. Decrease the number : Reduces the cyan component of green/cyan.
<b>Cy&amp;B Cy Level</b>		For adjusting the cyan/blue level of the video toward cyan. Increase the number : Enhances the cyan component of cyan/blue. Decrease the number : Reduces the cyan component of cyan/blue.
<b>Cy&amp;B B Level</b>		For adjusting the cyan/blue level of the video toward blue. Increase the number : Enhances the blue component of cyan/blue. Decrease the number : Reduces the blue component of cyan/blue.
<b>B&amp;Mg B Level</b>		For adjusting the blue/magenta level of the video toward blue. Increase the number : Enhances the blue component of blue/magenta. Decrease the number : Reduces the blue component of blue/magenta.
<b>B&amp;Mg Mg Level</b>		For adjusting the blue/magenta level of the video toward magenta. Increase the number : Enhances the magenta component of blue/magenta. Decrease the number : Reduces the magenta component of blue/magenta.
<b>R Rotation</b>	Max, 4 to 1, <b>Normal</b> , -1 to -4, Min	For adjusting the hue of the R-axis (red and cyan). Increase the number : Rotates hue of red toward yellow, and cyan toward blue. Decrease the number : Rotates hue of red toward magenta, and cyan toward green.
<b>G Rotation</b>		For adjusting the hue of the G-axis (green and magenta). Increase the number : Rotates hue of green toward blue, and magenta toward red. Decrease the number : Rotates hue of green toward yellow, and magenta toward blue.
<b>B Rotation</b>		For adjusting the hue of the B-axis (blue and yellow). Increase the number : Rotates hue of blue toward magenta, and yellow toward green. Decrease the number : Rotates hue of blue toward cyan, and yellow toward red.

## Menu Display and Detailed Settings

### TC/UB Menu

\* Default values are indicated in bold characters.

Item	Setting Values	Function
<b>TCG Source</b>	<b>Internal</b> External	For selecting the source of the time code generator. Internal : Selects the built-in time code generator of the camera recorder. External : Selects the time code generator connected to the [TC IN] terminal. <b>Memo :</b> ● If this item is set to "External", [TC Preset], [UB Preset], and [Drop Frame] cannot be set.
<b>TC Preset</b>	—	For setting the time code (hour, minute, second, frame). Display : Drop setting 02:02:25.20 : Non Drop setting 02:02:25:20
<b>UB Preset</b>	—	For setting the user's bit. (Digit by digit) Display : AB CD EF 01
<b>Drop Frame</b>	Non Drop <b>Drop</b>	For setting the framing mode of the time code generator. Non Drop : Internal time code generator works in the non-drop-frame mode. Use this setting when placing emphasis on the number of frames. Drop : Internal time code generator works in the drop-frame mode. Use this setting when placing emphasis on the recording time. <b>Memo :</b> ● This item can be set only when the frame rate of [Frame & Bit Rate] in the [Record Set] → [Record Format] menu is set to "60p", "30p", or "60i". When the frame rate is "24p", "Non Drop" becomes fixed and cannot be selected. When the frame rate is "50p", "25p", or "50i", this item appears as "---" and cannot be selected. (☞ Page 75)

### LCD/VF Menu

Item	Setting Values	Function
<b>Shooting Assist</b>		Menu for setting the Shooting Assist function. (☞ Page 89)
<b>Marker Setting...</b>		For setting items such as the safety zone and center mark. (☞ Page 90)
<b>Status Display...</b>		For setting displays related to the status screen. (☞ Page 90)
<b>LCD + VF</b>	<b>On</b> Off	For selecting a method to switch between the LCD monitor and viewfinder screen displays. (☞ Page 30) On : Displays images on the viewfinder at all times. Off : Turns off the viewfinder screen display when the LCD monitor is turned on.
<b>VF Display</b>	B & W <b>Color</b>	For selecting whether to display the image on the viewfinder screen in color or black-and-white. B & W : Displays the viewfinder image in black-and-white. Color : Displays the viewfinder image in color. <b>Memo :</b> ● The setting of this item is valid only in Camera mode. However, it becomes invalid in the AUX mode (U model) and during display of return video, and the camera recorder operates in the "Color" setting. ● When this item is set to "B & W", only the captured images are displayed in black-and-white. The status and menu screens are displayed in color.
<b>LCD Mirror Mode</b>	Mirror <b>Normal</b>	For specifying the image display method when facing the LCD monitor. (☞ Page 28) Mirror : Displays image after laterally inverting it. (Mirror display) Normal : Displays image without laterally inverting it. <b>Memo :</b> ● The setting of this item is valid only in Camera mode. However, it becomes invalid in the AUX mode (U model) and during display of return video, and the camera recorder operates in the "Normal" setting. ● During color bar and enlarged status displays, the "Mirror" setting is disabled. (☞ Page 115 [Color Bar Output]) (☞ Page 19 [Enlarged Status Display on LCD Monitor])

## Shooting Assist Item

\* Default values are indicated in bold characters.

Item	Setting Values	Function	
<b>Focus Assist</b>	ACCU-Focus <b>Normal</b>	For specifying the operation when the [FOCUS ASSIST] button on the camera recorder is pressed. (☞ Page 37) ACCU-Focus : Enables the Focus Assist and ACCU-Focus (forced focus) functions. The depth of field of the object becomes shallower to enable easier focusing. The ACCU-Focus function switches automatically to "Off" after about 10 seconds. Normal : Enables only the Focus Assist function. The focused area is displayed in color to enable easier focusing. Display color can be specified with [Color].	
	<b>Color</b>	<b>Blue</b> Green Red	For setting the display color of the focused area when Focus Assist is activated. Blue : Displays the focused area in blue. Green : Displays the focused area in green. Red : Displays the focused area in red.
	<b>Level</b>	High <b>Middle</b> Low	For setting the display range of the focused area when Focus Assist is activated. High : Sets the display range wider than Middle. Middle : Sets the display range to standard. Low : Sets the display range narrower than Middle.
<b>Zebra</b>	2Patterns <b>1Pattern</b>	For selecting the number of zebra patterns to be displayed. 2Patterns : Displays 2 types of zebra patterns (Zebra1 and Zebra2). 1Pattern : Displays 1 type of zebra pattern (Zebra1).	
	<b>Top1</b>	Over, 100% to 85%, <b>80%</b> , 75% to 5% (In 5 % increments)	For setting the maximum luminance level for the "Zebra1" display. <b>Memo :</b> ● The Bottom1 value is automatically adjusted during setting of the Top1 value to ensure that a Top1 > Bottom1 relationship is always maintained.
	<b>Bottom1</b>	100% to 75%, <b>70%</b> , 65% to 0% (In 5 % increments)	For setting the minimum luminance level for the "Zebra1" display. <b>Memo :</b> ● The Top1 value is automatically adjusted during setting of the Bottom1 value to ensure that a Top1 > Bottom1 relationship is always maintained.
	<b>Top2</b>	<b>Over</b> , 100% to 5% (In 5 % increments)	For setting the maximum luminance level for the "Zebra2" display. <b>Memo :</b> ● This item cannot be selected when [Zebra] is set to "1Pattern". ● The Bottom2 value is automatically adjusted during setting of the Top2 value to ensure that a Top2 > Bottom2 relationship is always maintained.
	<b>Bottom2</b>	100% to 85%, <b>80%</b> , 75% to 0% (In 5 % increments)	For setting the minimum luminance level for the "Zebra2" display. <b>Memo :</b> ● This item cannot be selected when [Zebra] is set to "1Pattern". ● The Top2 value is automatically adjusted during setting of the Bottom2 value to ensure that a Top2 > Bottom2 relationship is always maintained.
<b>Peaking Frequency</b>	High <b>Middle</b> Low	For setting the frequency range for applying contour enhancement using the [VF PEAKING] adjustment knob or [LCD PEAKING +/-] button. High : Emphasizes the high frequency range. Middle : Emphasizes the intermediate frequency range. Low : Emphasizes the low frequency range.	



## Menu Display and Detailed Settings

### LCD/VF Menu (continued)

#### Marker Setting Item

(☞ Page 112 [Marker and Safety Zone Displays (Camera Mode Only, Excluding AUX Mode)])

\* Default values are indicated in bold characters.

Item	Setting Values	Function
<b>Aspect Ratio *1</b>	4:3, 14:9, <b>16:9</b> , 16:9 (+4:3), 2.35:1 Center, 2.35:1C.HeadRM, 1.85:1 Center, 1.85:1C.HeadRM, 1.66:1, 1.75:1	For selecting the final image aspect ratio to be used from the overall angle of view.  <b>Memo :</b> ● When [Aspect Ratio] in the [Record Format] menu is set to “4:3”, this item is fixed at “4:3” and cannot be selected. (☞ Page 75)
<b>Aspect Marker *1</b>	Line+Halftone Halftone Line <b>Off</b>	For specifying how boundary markers are to be used to indicate the parts of an image that are beyond the range of the aspect ratio selected in [Aspect Ratio]. Line+Halftone : Displays the boundary using lines, and areas outside the boundary in halftone. Halftone : Displays areas outside the boundary in halftone. Line : Displays the boundary using lines. Off : Hides the boundary markers.
<b>Safety Zone *1</b>	95%, 93%, 90%, 88%, 80%, <b>Off</b>	For setting the percentage of area that is to be deemed as valid area (Safety Zone) within the boundary of the aspect ratio selected in [Aspect Ratio].
<b>Center Mark *1</b>	On <b>Off</b>	For specifying whether to display a mark to indicate the screen center within the aspect ratio selected in [Aspect Ratio]. On : Displays the center mark. Off : Hides the center mark.

\*1: Regardless of the setting, the marker does not appear during Clip Review, return video display, and in the AUX mode (U model) and Media mode.

#### Status Display Item

This menu is used to set the status displays on the LCD monitor and viewfinder screens.

Item	Setting Values	Function
<b>F.No/Iris Indicator</b>	F.No+Iris Ind. F.No <b>Off</b>	For specifying whether to display the iris position/iris level mark in the status display on the LCD monitor and viewfinder screens. F.No+Iris Ind. : Displays the iris position/level. F.No : Displays the iris position. Off : Hides the iris position/iris level mark.
<b>Filter</b>	On <b>Off</b>	For specifying whether to display the filter position in the status display on the LCD monitor and viewfinder screens. On : Displays the filter position. Off : Hides the filter position.
<b>Video Format</b>	<b>On</b> Off	For specifying whether to display the recording/playback video format in the status display on the LCD monitor and viewfinder screens. On : Displays the video format mode. Off : Hides the video format mode.
<b>Media Remain</b>	<b>On</b> Off	For specifying whether to display the remaining space of the recording SDHC card in the status display on the LCD monitor and viewfinder screens. On : Displays the remaining space on the SDHC card. Off : Hides the remaining space on the SDHC card. However, when the remaining space warning is displayed, the information appears regardless of the setting.

\* Default values are indicated in bold characters.

Item	Setting Values	Function
<b>TC/UB</b>	<b>On</b> Off	For specifying whether to display the time code/user's bit rate in the status display on the LCD monitor and viewfinder screens. On : Displays the time code or user's bit rate. Whether time code or user's bit rate is displayed is determined by the setting of the [TC DISPLAY] switch on the inner panel of the camera recorder's LCD monitor. Off : Hides the time code or user's bit rate.
<b>Audio Meter</b>	<b>On</b> Off	For specifying whether to display the audio level meter in the status display on the LCD monitor and viewfinder screens. On : Displays the audio level meter. Off : Hides the audio level meter.
<b>Battery Info</b>	Time Capacity% <b>Voltage</b>	For setting the battery information to be displayed on the status screen when an AntonBauer or IDX battery that supports communication is loaded. The status screen is displayed on the LCD monitor and/or viewfinder. The battery information appears only on the STATUS 1 screen in Camera mode. (Page 104) Time : Displays the remaining battery power in minutes. "min" Capacity% : Displays the remaining battery power in percentage. "%" Voltage : Displays the current battery voltage in units of 0.1 V. "V" <b>Memo :</b> <ul style="list-style-type: none"> <li>When a battery other than the one recommended (communication supported) is used, "Voltage" may sometimes be displayed even when "Time" or "Capacity%" is selected.</li> <li>When "Time" or "Capacity%" is selected, the battery mark that appears before the value changes according to the remaining battery power.  <input type="checkbox"/> RES : 12 % and below, <input type="checkbox"/> : 13 % - 29 %, <input type="checkbox"/> : 30 % - 59 %, <input type="checkbox"/> : 60 % - 100 %</li> <li>Display changes to " <input type="checkbox"/> RES " once the battery power falls below 12 %.</li> <li>When calibration of the battery is required, " <input type="checkbox"/> CAL " appears for 2 seconds after every 30 seconds of the voltage display.</li> <li>CALIBRATION is a state that requires renewal of the battery power information. The battery is able to function as usual without calibration. However, calibration is recommended as correct information of the remaining power and time cannot be obtained otherwise. For more details, refer to the instruction manual of the battery.</li> <li>The remaining battery power and remaining time are intended as reference values for the shooting duration.</li> <li>When an IDX battery is loaded while the camera recorder is connected to a KA-MR100G (Memory Recorder), the "Time" display setting may be disabled even when a recommended battery (communication supported) is used.</li> </ul>
<b>Date Style</b>	<b>DMY (E model)</b> <b>MDY (U model)</b> YMD	For setting the date display sequence in the status display on the LCD monitor and viewfinder screens. DMY : Day/Month/Year MDY : Month/Day/Year YMD : Year/Month/Day
<b>Time Style</b>	<b>24hour (E model)</b> <b>12hour (U model)</b>	For setting the time display in the status display on the LCD monitor and viewfinder screens. 24hour : 24-hour display. 12hour : 12-hour display. (AM/PM)
<b>Shutter Disp.</b>	DEG <b>SEC</b>	For setting the shutter display in the status display on the LCD monitor and viewfinder screens. DEG : Displays the shutter speed in degrees in the same way as film cameras. SEC : Displays the shutter speed in seconds. <b>Memo :</b> <ul style="list-style-type: none"> <li>"DEG" is selectable only when [Frame &amp; Bit Rate] is set to "24p (SP)", "24p (HQ)", "25p (SP)", or "25p (HQ)". When [Frame &amp; Bit Rate] is set to other values, the shutter display setting is fixed at "SEC" and cannot be selected. (Page 75)</li> <li>When a Remote Control Unit is connected, the shutter display setting is fixed at "SEC" regardless of the [Frame &amp; Bit Rate] setting.</li> </ul>

## Menu Display and Detailed Settings

### A/V Out Menu

\* Default values are indicated in bold characters.

Item	Setting Values	Function
<b>Output Terminal</b>	Composite <b>Component</b> Off	For setting output signals from the [Y/VIDEO]/[PB]/[PR] video signal output terminal (BNC) on the side of the camera recorder. Composite : Outputs composite signals to the [Y/VIDEO] video signal output terminal. Component : Outputs component signals. Off : Signals are not output.
<b>Set Up</b>	<b>7.5% (U model)</b> <b>0.0% (E model)</b>	For selecting whether to add a setup signal to the video signal output from the [Y/VIDEO]/[PB]/[PR] video signal output terminal (BNC) on the side of the camera recorder. A setup signal can also be selected during signal input from the [IEEE1394] terminal. 7.5% : Adds setup signal. 0.0% : Setup signal is not added. <b>Memo :</b> <ul style="list-style-type: none"> <li>When [Frame &amp; Bit Rate] is set to "50p (SP)", "50p (HQ)", "50i (SP)", "50i (HQ)", "25p (SP)", or "25p (HQ)", this item appears as "---" and cannot be selected. (Page 75)</li> <li>Depending on the menu settings of the camera recorder and the condition of the cable connected to it, the setup signal setting may be fixed at "0.0%". "0.0%" is displayed in gray in this case.</li> </ul>
<b>HD/SD-SDI Out</b>	HD-SDI SD-SDI <b>Off</b>	For specifying whether to output SDI signals from the [HD/SD-SDI] output terminal on the side of the camera recorder. HD-SDI : Outputs HD-SDI signals. Embedded (superimposed) audio signals and the time code are also output. SD-SDI : Outputs SD-SDI signals down converted from HD. When [System Definition] in the [Record Format] menu is set to "HD (MPEG2)" (Page 75), SD-SDI signals down converted from HD are output. Embedded (superimposed) audio signals and the time code are also output. Off : SDI signals are not output. <b>Memo :</b> <ul style="list-style-type: none"> <li>When [System Definition] in the [Record Format] menu is set to "SD (DV)", "HD-SDI" cannot be selected. Only SD-SDI signals are output. (Page 75)</li> <li>When DV signals are input from the [IEEE1394] terminal, "HD-SDI" cannot be selected.</li> <li>User's bit output from the [HD/SD-SDI] output terminal is used as a flag to determine valid video signals. Therefore, accurate values will not be output.</li> </ul>
<b>Down Convert</b>	Side Cut <b>Letter Box</b> Squeeze	For setting the style of displaying down-converted images on a 4:3 aspect ratio screen. This setting applies to all Composite/SD-SDI/DV outputs. Side Cut : Displays image with the left and right sides cut off. Letter Box : Displays as a wide image with the top and bottom blackened. Squeeze : Displays image that is squeezed horizontally. <b>Memo :</b> <ul style="list-style-type: none"> <li>When [System Definition] in the [Record Format] menu is set to "SD (DV)", this item appears as "---" and cannot be selected. (Page 75)</li> </ul>
<b>Analog Out Char.</b>	On <b>Off</b>	For selecting whether to display status and menu characters on the screen output from the [Y/VIDEO]/[PB]/[PR] video signal output terminal (BNC) on the side of the camera recorder. On : Turns on display. Off : Turns off display. <b>Memo :</b> <ul style="list-style-type: none"> <li>When [Analog Out Char.] is set to "On", the details shown on the viewfinder are also displayed in the image output from the video signal output terminal (BNC).</li> </ul>
<b>SDI Out Char.</b>	On <b>Off</b>	For selecting whether to display status and menu characters on the screen output from the [HD/SD-SDI] output terminal on the side of the camera recorder. On : Turns on display. Off : Turns off display.

\* Default values are indicated in bold characters.

Item	Setting Values	Function																																		
<b>Audio Monitor</b>	Stereo <b>Mix</b>	<p>For setting the audio sound of the [PHONES] terminal to stereo or mixed sound when the [MONITOR SELECT] switch on the side of the camera recorder is set to "Both".</p> <p>Mix : Outputs mixed sound (outputs mixed sound of CH-1 and CH-2 to both L and R). Stereo : Outputs stereo sound (outputs audio sound of CH-1 to L, and CH-2 to R). When a monitor speaker is used, only the audio sound of CH-1 is output.</p> <p>■ [PHONES] terminal, speaker, and RCA outputs according to the combination of the camera recorder's [MONITOR SELECT] switch settings and [Audio Monitor] settings</p> <table border="1"> <thead> <tr> <th rowspan="2">[MONITOR SELECT] Setting</th> <th rowspan="2">[Audio Monitor] Setting</th> <th colspan="2">Output from [PHONES] Terminal</th> <th rowspan="2">Speaker Output</th> <th colspan="2">RCA Output</th> </tr> <tr> <th>L</th> <th>R</th> <th>CH1</th> <th>CH2</th> </tr> </thead> <tbody> <tr> <td>[CH-1]</td> <td>—</td> <td colspan="2">CH1</td> <td>CH1</td> <td rowspan="3">CH1</td> <td rowspan="3">CH2</td> </tr> <tr> <td rowspan="2">[BOTH]</td> <td>[Mix]</td> <td colspan="2">CH1+CH2</td> <td>CH1+CH2</td> </tr> <tr> <td>[Stereo]</td> <td>CH1</td> <td>CH2</td> <td>CH1</td> </tr> <tr> <td>[CH-2]</td> <td>—</td> <td colspan="2">CH2</td> <td>CH2</td> <td></td> <td></td> </tr> </tbody> </table>	[MONITOR SELECT] Setting	[Audio Monitor] Setting	Output from [PHONES] Terminal		Speaker Output	RCA Output		L	R	CH1	CH2	[CH-1]	—	CH1		CH1	CH1	CH2	[BOTH]	[Mix]	CH1+CH2		CH1+CH2	[Stereo]	CH1	CH2	CH1	[CH-2]	—	CH2		CH2		
[MONITOR SELECT] Setting	[Audio Monitor] Setting	Output from [PHONES] Terminal			Speaker Output	RCA Output																														
		L	R	CH1		CH2																														
[CH-1]	—	CH1		CH1	CH1	CH2																														
[BOTH]	[Mix]	CH1+CH2		CH1+CH2																																
	[Stereo]	CH1	CH2	CH1																																
[CH-2]	—	CH2		CH2																																

## Others Menu

Item	Setting Values	Function
<b>Alarm Level</b>	<b>High</b> Middle Low Off	<p>For selecting whether to turn on the alarm tone as well as setting the volume. Alarm tone is output from the monitor speaker or [PHONES] terminal.</p> <p>High : Outputs alarm tone at a high volume level. Middle : Outputs alarm tone at a medium volume level. Low : Outputs alarm tone at a low volume level. Off : Alarm tone is not output.</p>
<b>Genlock Input</b>	<b>BNC</b> Adapter	<p>For selecting a destination to input video synchronizing signal.</p> <p>BNC : [GENLOCK/AUX IN] terminal at the side of the camera recorder. Adapter : Adapter connected to the accessory connection terminal (68 pin) at the back of the camera recorder.</p> <p><b>Note :</b></p> <ul style="list-style-type: none"> <li>This item cannot be selected when the [GENLOCK/AUX] switch is set to "AUX". (U model)</li> </ul>
<b>Genlock Adjust...</b>	—	<p>For adjusting the H phase of the video signal of this camera recorder with respect to the synchronizing signal input. (☞ Page 127)</p> <p><b>Note :</b></p> <ul style="list-style-type: none"> <li>This item cannot be selected when the [GENLOCK/AUX] switch is set to "AUX". (U model)</li> </ul>
<b>Return Input</b>	<b>Adapter</b> Studio	<p>For selecting a destination to input the return video.</p> <p>Adapter : Adapter connected to the accessory connection terminal (68 pin) at the back of the camera recorder. Studio : Adapter connected to the [STUDIO] terminal at the side of the camera recorder.</p> <p><b>Note :</b></p> <ul style="list-style-type: none"> <li>This item cannot be selected when the [GENLOCK/AUX] switch is set to "AUX". (U model)</li> </ul>
<b>Return Aspect</b>	<b>16:9</b> 4:3	<p>For selecting the aspect ratio of the return video.</p> <p>16:9 : Select this setting when the return video is a squeeze signal. 4:3 : Select this setting when the return video is a 4:3 aspect signal (including Letter Box).</p> <p><b>Note :</b></p> <ul style="list-style-type: none"> <li>This item cannot be selected when the [GENLOCK/AUX] switch is set to "AUX". (U model)</li> </ul>

## Others Menu (continued)

\* Default values are indicated in bold characters.

Item	Setting Values	Function										
<b>Tally System</b>	Studio Ext <b>Int</b>	For setting the display conditions of the camera recorder's tally lamps (front/back). Studio : Displays according to the TALLY IN/PREVIEW IN signals from an external device, such as a Remote Control Unit. Ext : Displays mainly the status of external devices. Int : Displays mainly the status of the camera recorder.										
<b>Front Tally</b>	On <b>Blink</b> Off	For specifying the illumination settings of the camera recorder's front tally lamp during recording. On : Lights up only during recording. Blink : Blinks after the [REC] trigger button is pressed until recording starts, and lights up during recording. Off : Turns off the tally lamp.										
<b>Back Tally</b>	On <b>Blink</b> Off	For specifying the illumination settings of the camera recorder's back tally lamp during recording. On : Lights up only during recording. Blink : Blinks after the [REC] trigger button is pressed until recording starts, and lights up during recording. Off : Turns off the tally lamp.										
<b>1394 Rec Trigger</b>	Ext Series Split Synchronize <b>Off</b>	For setting the recording trigger for the external recording device connected to the [IEEE1394] terminal. Ext : Outputs recording trigger to the external system only. (Recording is not performed by the internal system.) Series : Outputs recording trigger to enable consecutive recording by the internal and external systems. Split : Outputs separate recording triggers to the internal and external systems. Synchronize : Outputs recording trigger simultaneously to the internal and external systems. Off : Recording trigger is not output to the external system. <b>Memo :</b> <ul style="list-style-type: none"> <li>This item is selectable only in Camera mode. It cannot be set when recording is in progress on the camera recorder or an external device.</li> <li>When the external recording device connected to the [IEEE1394] terminal switches to the recording mode according to the settings, switching of operation mode using the [CAM/MEDIA] button and the Clip Review function will be disabled.</li> <li>When [1394 Rec Trigger] is set to "Split", the [REC] button on the side of the camera recorder becomes a Rec Start/Stop button for the external device. (Page 12)</li> <li>When the [REC] button is pushed immediately after the power is turned on or after a menu setting is changed, recording with the external device might start about 10 seconds late.</li> </ul>										
<b>1394 Auto Power Off</b>	Enable <b>Disable</b>	For setting whether to automatically turn off the power of the external recording device connected to the [IEEE1394] terminal when the [POWER] switch of the camera recorder is turned off. Enable : Turns off the power automatically. Disable : Disables this function. <b>Memo :</b> <ul style="list-style-type: none"> <li>The IEEE1394 control is only valid for external devices with a POWER OFF button.</li> </ul>										
<b>Mode LED</b>	<b>On</b> Off	For specifying the illumination settings of the operation mode indicator on the side control panel of the camera recorder. On : Lights up as below according to the operation mode. (Page 8) Off : Turns off the indicator. <table border="1" style="width: 100%; margin-top: 10px;"> <thead> <tr> <th>Operation Mode</th> <th>Color</th> </tr> </thead> <tbody> <tr> <td>Camera Mode</td> <td>Blue/Purple</td> </tr> <tr> <td>Media Mode (SD Card Mode)</td> <td>Green</td> </tr> <tr> <td>Media Mode (IEEE1394 Mode)</td> <td>Orange</td> </tr> <tr> <td>USB Mode</td> <td>Orange</td> </tr> </tbody> </table>	Operation Mode	Color	Camera Mode	Blue/Purple	Media Mode (SD Card Mode)	Green	Media Mode (IEEE1394 Mode)	Orange	USB Mode	Orange
Operation Mode	Color											
Camera Mode	Blue/Purple											
Media Mode (SD Card Mode)	Green											
Media Mode (IEEE1394 Mode)	Orange											
USB Mode	Orange											

\* Default values are indicated in bold characters.

Item	Setting Values	Function
<b>Reset All</b>	—	Resets all menu settings. Select [Reset All] in the “Reset” menu and press the Set button (●). The message “Resetting...” appears. After the resetting process is complete, the message “Complete” appears for about 1 second. Reset will not be performed if [Cancel] is selected. <b>Memo:</b> _____ <ul style="list-style-type: none"> <li>• [Date/Time] (☞ Page 95) and [Time Zone] (☞ Page 95) cannot be reset.</li> <li>• This item is not selectable when recording in Camera mode, during Clip Review, and in Media mode.</li> </ul>
<b>Date/Time</b>	—	For setting the year, month, day, hour, and minute. <b>Memo:</b> _____ <ul style="list-style-type: none"> <li>• The display order of the date (year, month, and day) follows the [Date Style] setting in the [Status Display] menu. However, the 24-hour format is used for the hour display regardless of the [Time Style] setting. (☞ Page 91)</li> </ul>
<b>Time Zone</b>	UTC-00:30 to UTC-12:00, UTC, UTC+14:00 to UTC+00:30 (In increments of 30 minutes)	For setting the UTC time difference in units of 30 minutes. <b>[Default values : UTC-05:00 (U model), UTC (E model)]</b> <b>Memo:</b> _____ <ul style="list-style-type: none"> <li>• If [Date/Time] is already set, the [Date/Time] item is automatically adjusted when [Time Zone] is altered.</li> </ul>
<b>System Information</b>	For displaying the usage time of the internal fan. <b>Memo:</b> _____ <ul style="list-style-type: none"> <li>• Under normal environment, dust will accumulate on the internal fan when the camera recorder is used over a long period. Dust may enter the camera recorder especially if it is used outdoors. This may affect the image and sound quality of the camera recorder. Check and replace the fan after every 9000 hours (suggested guideline).</li> </ul>	
<b>Fan Hour</b>		

### Others Menu (continued)

#### Genlock Adjust Item

\* Default values are indicated in bold characters.

Item	Setting Values	Function
<b>Analog SD H Phase</b>	Min, -27 to <b>0</b> to 81, Max	For adjusting the H phase of the SD analog signal of the camera recorder with respect to the external synchronizing signal input to the [GENLOCK INPUT] terminal. Increase value : Advances the H phase. Decrease value : Delays the H phase.
<b>Analog HD H Phase</b>	Min, -1023 to <b>0</b> to 1022, Max	For adjusting the H phase of the HD analog signal of the camera recorder with respect to the external synchronizing signal input to the [GENLOCK INPUT] terminal. Increase value : Advances the H phase. Decrease value : Delays the H phase.  <b>Memo :</b> _____ <ul style="list-style-type: none"> <li>When [System Definition] in the [Record Format] menu is set to "SD (DV)", this item appears as "---" and cannot be selected. (☞ Page 75)</li> </ul>
<b>SD-SDI H Phase</b>	Min, -372 to -1, <b>0</b> , 1 to 372, Max	For adjusting the H phase of the SD-SDI signal of the camera recorder with respect to the external synchronizing signal input to the [GENLOCK INPUT] terminal. Increase value : Advances the H phase. Decrease value : Delays the H phase.  <b>Memo :</b> _____ <ul style="list-style-type: none"> <li>When [HD/SD-SDI Out] in the [A/V Out] menu is set to a setting other than "SD (DV)", this item appears as "---" and cannot be selected. (☞ Page 92)</li> </ul>
<b>HD-SDI H Phase</b>	Min, -1023 to <b>0</b> to 1022, Max	For adjusting the H phase of the HD-SDI signal of the camera recorder with respect to the external synchronizing signal input to the [GENLOCK INPUT] terminal. Increase value : Advances the H phase. Decrease value : Delays the H phase.  <b>Memo :</b> _____ <ul style="list-style-type: none"> <li>When [HD/SD-SDI Out] in the [A/V Out] menu is set to a setting other than "HD-SDI", this item appears as "---" and cannot be selected. (☞ Page 92)</li> </ul>

**Memo :** \_\_\_\_\_

- You can alter the setting value in increments of 10 by pressing down the cross-shaped button (▲▼) for 2 seconds or longer. (Excluding the [Analog SD H Phase] item)



## Media Menu

\* Default values are indicated in bold characters.

Item	Function
<b>Format Media</b>	For formatting (initializing) an SDHC card. Select a card slot (A or B), select [Format] from [Cancel]/[Format], and press the Set button (●) to format (initialize) the card. (☞ Page 33 [Formatting (Initializing) SDHC Cards])
<b>Restore Media</b>	For restoring an SDHC card. Select a card slot (A or B), select [Restore] from [Cancel]/[Restore], and press the Set button (●) to restore the SDHC card. (☞ Page 34 [Restoring the SDHC Card])  <b>Memo:</b> ● This item appears only when the SDHC card needs to be restored. However, it is not selectable when recording in Camera mode and during Clip Review.

## Setup File Manage Menu

Menu settings and button operations ([SHUTTER], [AE LEVEL], etc.) can be saved.  
It is useful to save settings according to different shooting conditions.

Item	Setting Values	Function
<b>Load File...</b>	—	Loads the settings. (☞ Page 121)
<b>Store File...</b>	—	Saves the settings. (☞ Page 120)
<b>Reset File...</b>	—	Restores the saved settings to their default values. (☞ Page 121)

## Adding/Editing Frequently Used Menu Items (Favorites Menu)

You can select and add/edit frequently used menu items freely to create a personal menu screen (Favorites Menu).

**Memo :**

- [Favorites Menu] is valid only in Camera mode (except AUX mode), and remains common even when the recording format is changed.
- Up to 20 menu items can be added (two pages on the screen).
- Added items in [Favorites Menu] will not be reset even when [Reset All] in the main menu is executed.

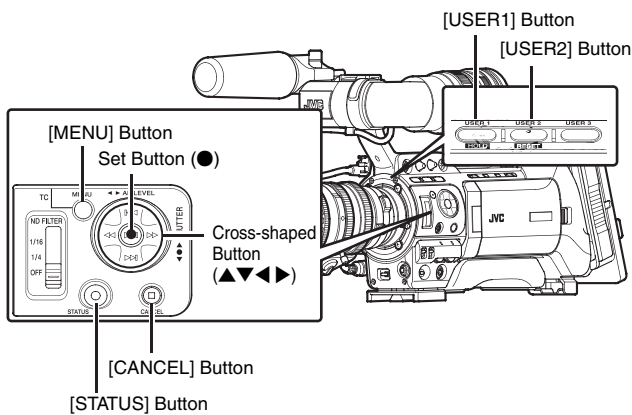

### Adding Menu Items to Favorites Menu

**1** Press the [MENU] button to open the [Main Menu] screen.

**2** Select the menu or submenu item to add.

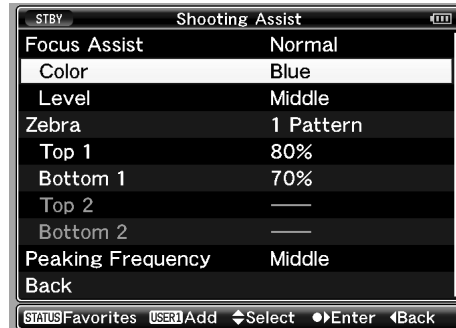

**Memo :**

- Adding items to [Favorites Menu] cannot be performed in the following cases. [USER1 Add] is displayed in gray in the operation guide.
  - Selected item is already added to [Favorites Menu].
  - Number of menu items that can be added (20 items) is exceeded.

**3** Press the [USER1] button.

A screen to confirm the addition appears.

**4** Select [Add] and press the Set button (●).

The selected menu item is added to [Favorites Menu].

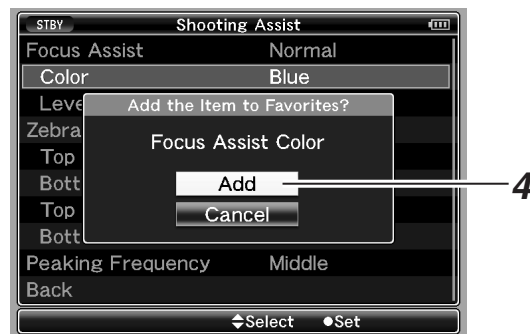

**Memo :**

- Long descriptive names may be displayed for the menu items in [Favorites Menu] to enable better understanding.

## Editing Favorites Menu

You can delete or change the order of the items added to [Favorites Menu].

### ■ Deleting Items from [Favorites Menu]

#### 1 Open the [Favorites Menu] screen.

- ① Press the [MENU] button to open the [Main Menu] screen.
- ② Press the [STATUS] button to open the [Favorites Menu] screen.

#### 2 Select [Edit Favorites] and press the Set button (●) or crossed-shaped button (▶).

The header turns magenta and the editing mode is activated.

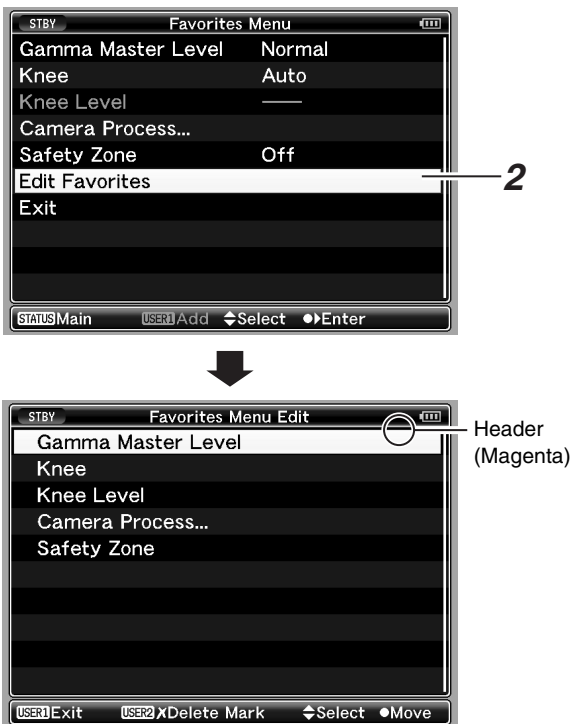

#### 3 Select the menu or submenu item to delete.

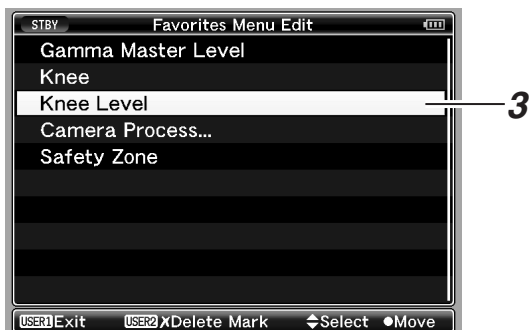

#### 4 Press the [USER2] button.

[Delete Mark] (X) appears at the beginning of the item.

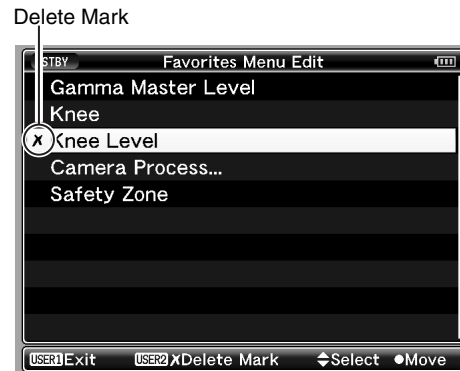

#### Memo :

- When the [USER2] button is pressed again while the menu item with [Delete Mark] (X) is selected, [Delete Mark] (X) disappears.

#### 5 Press the [USER1] button.

The option menu to exit the [Favorites Menu] editing mode appears.

#### 6 Select [Save & Exit] and press the Set button (●).



#### Memo :

- Deletion is not complete until the changes are saved with [Save & Exit].
- To exit the editing mode without deleting any items, select [Exit without Saving].
- To return to the editing mode, select [Cancel].

# Adding/Editing Frequently Used Menu Items (Favorites Menu) (continued)

## Editing Favorites Menu (continued)

### ■ Changing the Order of Items in [Favorites Menu]

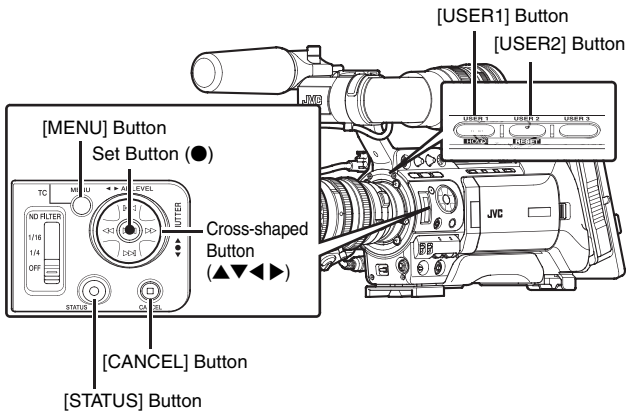

#### 1 Open the [Favorites Menu] screen.

- ① Press the [MENU] button to open the [Main Menu] screen.
- ② Press the [STATUS] button to open the [Favorites Menu] screen.

#### 2 Select [Edit Favorites] and press the Set button (●) or crossed-shaped button (▶).

The header turns magenta and the editing mode is activated.

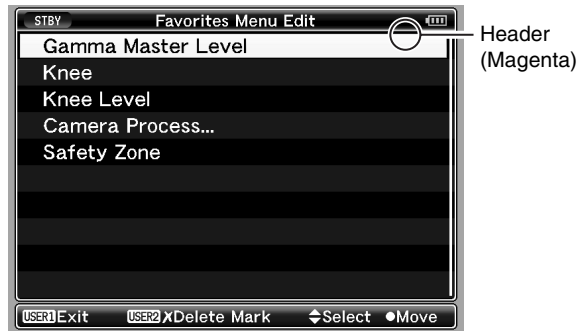

#### 3 Select the menu or submenu item to move and press the Set button (●).

The moving mode is activated and a position selection bar for the move appears.

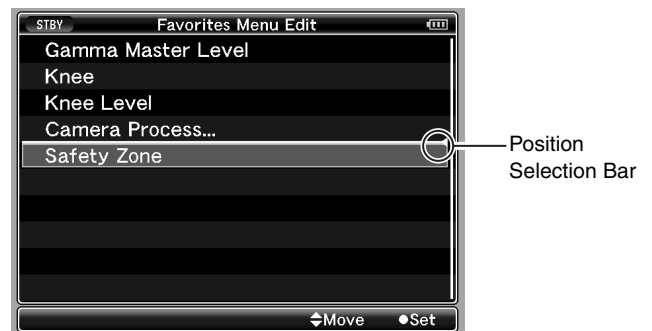
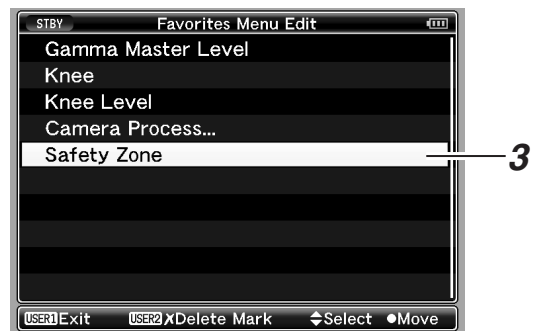

---

**4 Select the position to move to with the cross-shaped button (▲▼).**

Move the position selection bar with the cross-shaped button (▲▼) and select a position to move to.

**5 Press the Set button (●).**

The selected item moves to the new position.

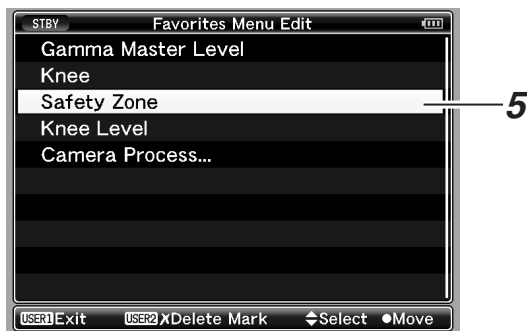

**6 Press the [USER1] button.**

The option menu to exit the [Favorites Menu] editing mode appears.

**7 Select [Save & Exit] and press the Set button (●).**



**Memo :**

- Moving is not complete until the changes are saved with [Save & Exit].
  - To exit the editing mode without saving any changes, select [Exit without Saving].
  - To return to the editing mode, select [Cancel].
-

# Status Screen in Camera Mode

## STATUS 0 Screen

The STATUS 0 screen is not displayed in the AUX mode. (U model)

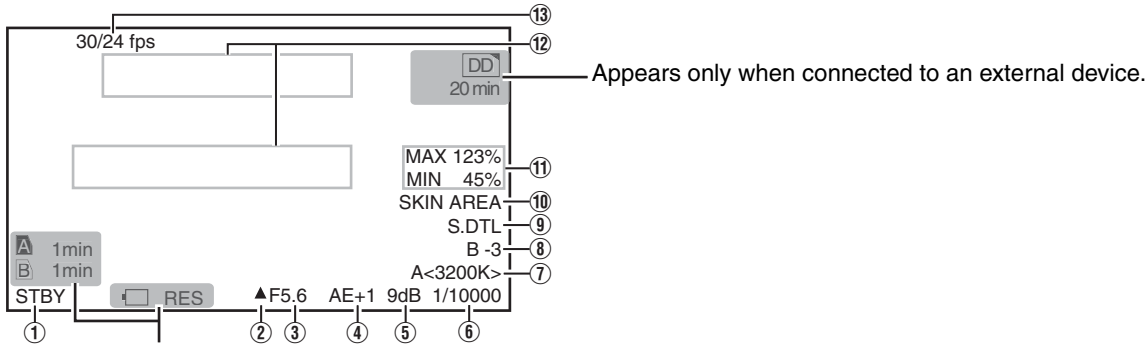

Appears only when a warning is displayed. (☞ Page 104)

Item	Description
① <b>Media Status</b>	<p>---- : No card found in the selected slot *</p> <p>STBY : Recording standby (recording pause)</p> <p>REC : Recording</p> <p>REVIEW : Clip Review (☞ Page 56)</p> <p>STBY<math>\square</math> : Pre Rec recording standby (☞ Page 58)</p> <p>REC<math>\square</math> : Pre Rec recording (☞ Page 58)</p> <p>STBY<math>\square</math> : Clip Continuous recording standby (☞ Page 59)</p> <p>REC<math>\square</math> : Clip Continuous recording (☞ Page 59)</p> <p>STBY<math>\square</math> (displayed in yellow) : Clip Continuous recording pause (☞ Page 59)</p> <p>STOP : Unable to record to the card in the slot</p> <p>POFF : Power OFF</p> <p>* When [Tally System] in the [Others] menu is set to "Studio", "----" is not displayed even when a card is not inserted into the slot. (☞ Page 94)</p>
② <b>Iris Status Mark</b>	<p>Indicates whether the brightness of the image is appropriate.</p> <p>▲ : Iris set higher than normal</p> <p>● : Iris set to normal</p> <p>▼ : Iris set lower than normal</p>
③ <b>Iris F-Number</b>	<p>Displays F-number of the lens iris.</p> <p>This is not displayed for some lens types, and when the lens cable is disconnected. (OPEN, F2, F2.8, F4, F5.6, F8, F11, F16, CLOSE)</p> <p><b>Memo :</b></p> <ul style="list-style-type: none"> <li>You can specify the type of display and whether to display the information using [F.No/Iris Indicator] of [Status Display] in the [LCD/VF] menu. (☞ Page 90)</li> </ul>
④ <b>AE Level</b>	<p>Appears when the AE function is activated and [AE LEVEL] in the [Camera Function] menu is set to a value other than "Normal". (☞ Page 78)</p> <p>(AE-3, AE-2, AE-1, AE+1, AE+2, AE+3)</p>
⑤ <b>Gain</b>	<p>Displays the gain value when it is not "0dB".</p> <p>(3dB, 6dB, 9dB, 12dB, 15dB, 18dB, ALC)</p>
⑥ <b>Shutter</b>	<p>Displays the current shutter speed when [Shutter] in the [Camera Function] menu is set to [Step]/[Variable] and the shutter is ON. (☞ Page 78)</p> <p>EEI : Displayed when [Shutter] is set to "EEI" (auto adjustment mode).</p> <p>FAS : Displayed when shutter or gain is set to the auto adjustment mode.</p> <p><b>Memo :</b></p> <ul style="list-style-type: none"> <li>The variable range of the shutter speed varies according to the video format settings. (☞ Page 41)</li> </ul>
⑦ <b>White Balance Mode</b>	<p>Displays the current white balance mode.</p> <p>A&lt;***00K&gt;, B&lt;**00K&gt;, P&lt;**00K&gt; ("**00" indicates color temperature)</p> <p>FAW : When the Fulltime Auto White balance mode is ON</p> <p>MANU : Manual White Balance mode (only during control using the Remote Control Unit)</p>

Item	Description																																														
⑧ Black Toe	Appears when [Black Toe] in the [Camera Process] menu is set to a value other than “Normal”. (☞ Page 82) B+1 to B+5 : Displays the “Stretch Level” when [Black Toe] is set to “Stretch” (Level 1 to Level 5) B-1 to B-5 : Displays the “Compress Level” when [Black Toe] is set to “Compress” (Level 1 to Level 5) No display : When [Black Toe] is set to “Normal”																																														
⑨ Skin Detail Operation	Appears as “S.DTL” when the Skin Detail function is turned ON.																																														
⑩ Operation of Functions	SKIN AREA : Blinks when the Skin Area display is ON. FOCUS : Appears when the Focus Assist function is activated. When “ACCU-Focus” is enabled, “ACCU-FOCUS” blinks for about 10 seconds while Focus Assist starts up, after which the “FOCUS” indicator lights up. When [ACCU-Focus] is operating, it is forcibly turned OFF after recording starts. (☞ Page 89)																																														
⑪ Luminance Information	Appears when the Spot Meter function is activated. For details of the display, refer to [Setting Spot Meter] (☞ Page 55). MAX : Maximum luminance MIN : Minimum luminance																																														
⑫ Event/Warning Display Area	Displays the settings for about 3 seconds when the gain or shutter speed is manually changed. For other messages displayed in this area, refer to [Error Displays and Actions] (☞ Page 134).																																														
	<table border="1"> <thead> <tr> <th>Displayed Content</th> <th>Setting Status</th> </tr> </thead> <tbody> <tr> <td>GAIN **dB (** : 0, 3, 6, 9, 12, 15, 18)</td> <td>Gain value is altered</td> </tr> <tr> <td>GAIN ALC</td> <td>Gain is set to “ALC”</td> </tr> <tr> <td>FULL AUTO ON, FULL AUTO OFF</td> <td>[FULL AUTO] is turned “ON/OFF”</td> </tr> <tr> <td>ZEBRA ON, ZEBRA OFF</td> <td>[Zebra] is turned “ON/OFF”</td> </tr> <tr> <td>FOCUS ASSIST ON, FOCUS ASSIST OFF</td> <td>[Focus Assist] is turned “ON/OFF”</td> </tr> <tr> <td>SHUTTER ** (****K : 1/6, 1/6.25, 1/7.5, 1/12, 1/12.5, 1/15, 1/24, 1/25, 1/30, 1/48, 1/50, 1/60, 1/100, 1/120, 1/250, 1/500, 1/1000, 1/2000, 1/4000, 1/10000)</td> <td>Shutter speed is altered *1</td> </tr> <tr> <td>V. SHUTTER **** (**** : 1/24.01 to 1/1998.0)</td> <td>Variable shutter speed is altered *1</td> </tr> <tr> <td>SHUTTER OFF ** (**** is the standard shutter value in the respective modes.)</td> <td>Shutter is turned “OFF” *1</td> </tr> <tr> <td>WHITE BAL * &lt;****K&gt; (* : A, B, PRESET) (****, K indicates color temperature)</td> <td>White balance value is altered</td> </tr> <tr> <td>WHITE BAL FAW</td> <td>FAW (Fulltime Auto White balance) is activated</td> </tr> <tr> <td>FILTER **** (** : OFF, 1/4ND, 1/16ND)</td> <td>[ND FILTER] setting is altered</td> </tr> <tr> <td>AE LEVEL ** (**** : -3, -2, -1, NORMAL, +1, +2, +3)</td> <td>[AE LEVEL] value is altered</td> </tr> <tr> <td>SPOT METER **** (**** : ON, FIXED, OFF, SELECT)</td> <td>Spot meter status is changed (☞ Page 55)</td> </tr> <tr> <td>BLACK NORMAL</td> <td>[Black Toe] is set to “Normal”</td> </tr> <tr> <td>BLACK STRETCH * (* : 1,2,3,4,5,)</td> <td>[Stretch Level] of [Black Toe] is altered</td> </tr> <tr> <td>BLACK COMPRESS * (* : 1,2,3,4,5,)</td> <td>[Compress Level] of [Black Toe] is altered</td> </tr> <tr> <td>REC SWITCH LOCKED, REC SWITCH UNLOCKED</td> <td>Record button lock switch is turned ON/OFF in Camera mode, or [REC] switch on the handle of the camera recorder is pressed while being locked</td> </tr> <tr> <td>SLOT SWITCHED * (* : A, B)</td> <td>Active SDHC slot is switched automatically or using the [SLOT SELECT] button in Camera mode.</td> </tr> <tr> <td>TRIGGER TO EXT</td> <td>Recording command is sent out from the [IEEE1394] terminal</td> </tr> <tr> <td>FRAME RATE rrrr/pp fps (rrrr : recording frame rate, pp : playback frame rate)</td> <td>Variable frame rate is adjusted using the cross-shaped button</td> </tr> <tr> <td>OK MARK ADDED, OK MARK DELETED</td> <td>OK mark is added or deleted (☞ Page 68)</td> </tr> <tr> <td colspan="2">Other Displays (☞ Page 134 [Error Displays and Actions])</td> </tr> </tbody> </table>	Displayed Content	Setting Status	GAIN **dB (** : 0, 3, 6, 9, 12, 15, 18)	Gain value is altered	GAIN ALC	Gain is set to “ALC”	FULL AUTO ON, FULL AUTO OFF	[FULL AUTO] is turned “ON/OFF”	ZEBRA ON, ZEBRA OFF	[Zebra] is turned “ON/OFF”	FOCUS ASSIST ON, FOCUS ASSIST OFF	[Focus Assist] is turned “ON/OFF”	SHUTTER ** (****K : 1/6, 1/6.25, 1/7.5, 1/12, 1/12.5, 1/15, 1/24, 1/25, 1/30, 1/48, 1/50, 1/60, 1/100, 1/120, 1/250, 1/500, 1/1000, 1/2000, 1/4000, 1/10000)	Shutter speed is altered *1	V. SHUTTER **** (**** : 1/24.01 to 1/1998.0)	Variable shutter speed is altered *1	SHUTTER OFF ** (**** is the standard shutter value in the respective modes.)	Shutter is turned “OFF” *1	WHITE BAL * <****K> (* : A, B, PRESET) (****, K indicates color temperature)	White balance value is altered	WHITE BAL FAW	FAW (Fulltime Auto White balance) is activated	FILTER **** (** : OFF, 1/4ND, 1/16ND)	[ND FILTER] setting is altered	AE LEVEL ** (**** : -3, -2, -1, NORMAL, +1, +2, +3)	[AE LEVEL] value is altered	SPOT METER **** (**** : ON, FIXED, OFF, SELECT)	Spot meter status is changed (☞ Page 55)	BLACK NORMAL	[Black Toe] is set to “Normal”	BLACK STRETCH * (* : 1,2,3,4,5,)	[Stretch Level] of [Black Toe] is altered	BLACK COMPRESS * (* : 1,2,3,4,5,)	[Compress Level] of [Black Toe] is altered	REC SWITCH LOCKED, REC SWITCH UNLOCKED	Record button lock switch is turned ON/OFF in Camera mode, or [REC] switch on the handle of the camera recorder is pressed while being locked	SLOT SWITCHED * (* : A, B)	Active SDHC slot is switched automatically or using the [SLOT SELECT] button in Camera mode.	TRIGGER TO EXT	Recording command is sent out from the [IEEE1394] terminal	FRAME RATE rrrr/pp fps (rrrr : recording frame rate, pp : playback frame rate)	Variable frame rate is adjusted using the cross-shaped button	OK MARK ADDED, OK MARK DELETED	OK mark is added or deleted (☞ Page 68)	Other Displays (☞ Page 134 [Error Displays and Actions])	
	Displayed Content	Setting Status																																													
	GAIN **dB (** : 0, 3, 6, 9, 12, 15, 18)	Gain value is altered																																													
	GAIN ALC	Gain is set to “ALC”																																													
	FULL AUTO ON, FULL AUTO OFF	[FULL AUTO] is turned “ON/OFF”																																													
	ZEBRA ON, ZEBRA OFF	[Zebra] is turned “ON/OFF”																																													
	FOCUS ASSIST ON, FOCUS ASSIST OFF	[Focus Assist] is turned “ON/OFF”																																													
	SHUTTER ** (****K : 1/6, 1/6.25, 1/7.5, 1/12, 1/12.5, 1/15, 1/24, 1/25, 1/30, 1/48, 1/50, 1/60, 1/100, 1/120, 1/250, 1/500, 1/1000, 1/2000, 1/4000, 1/10000)	Shutter speed is altered *1																																													
	V. SHUTTER **** (**** : 1/24.01 to 1/1998.0)	Variable shutter speed is altered *1																																													
	SHUTTER OFF ** (**** is the standard shutter value in the respective modes.)	Shutter is turned “OFF” *1																																													
	WHITE BAL * <****K> (* : A, B, PRESET) (****, K indicates color temperature)	White balance value is altered																																													
	WHITE BAL FAW	FAW (Fulltime Auto White balance) is activated																																													
	FILTER **** (** : OFF, 1/4ND, 1/16ND)	[ND FILTER] setting is altered																																													
	AE LEVEL ** (**** : -3, -2, -1, NORMAL, +1, +2, +3)	[AE LEVEL] value is altered																																													
	SPOT METER **** (**** : ON, FIXED, OFF, SELECT)	Spot meter status is changed (☞ Page 55)																																													
	BLACK NORMAL	[Black Toe] is set to “Normal”																																													
	BLACK STRETCH * (* : 1,2,3,4,5,)	[Stretch Level] of [Black Toe] is altered																																													
	BLACK COMPRESS * (* : 1,2,3,4,5,)	[Compress Level] of [Black Toe] is altered																																													
	REC SWITCH LOCKED, REC SWITCH UNLOCKED	Record button lock switch is turned ON/OFF in Camera mode, or [REC] switch on the handle of the camera recorder is pressed while being locked																																													
SLOT SWITCHED * (* : A, B)	Active SDHC slot is switched automatically or using the [SLOT SELECT] button in Camera mode.																																														
TRIGGER TO EXT	Recording command is sent out from the [IEEE1394] terminal																																														
FRAME RATE rrrr/pp fps (rrrr : recording frame rate, pp : playback frame rate)	Variable frame rate is adjusted using the cross-shaped button																																														
OK MARK ADDED, OK MARK DELETED	OK mark is added or deleted (☞ Page 68)																																														
Other Displays (☞ Page 134 [Error Displays and Actions])																																															
⑬ Frame Rate	Appears as xx/yy fps (xx: recording frame rate, yy: playback frame rate) only when “Variable Frame” is set in the [Rec Mode] menu. (☞ Page 76)																																														

\* 1 : The variable range of the shutter speed varies according to the video format settings. (☞ Page 41)



# Status Screen in Camera Mode (continued)

## STATUS 1 Screen

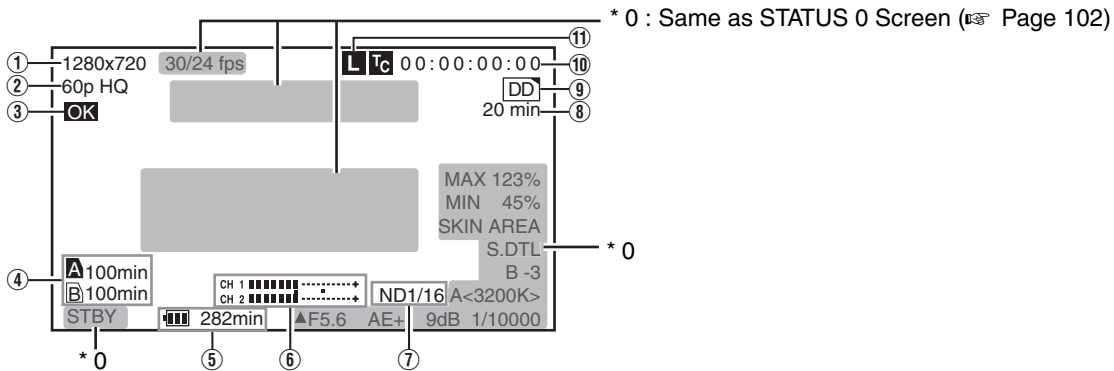

Item	Description																					
① Resolution	Displays the video image resolution. (1920×1080, 1440×1080, 1280×720, 720×480, 720×576)																					
② Frame Rate/Bit Rate	Displays the frame rate and bit rate in pairs. (60p HQ, 30p HQ, 60i HQ, 60p SP, 30p SP, 60i SP, 50p HQ, 25p HQ, 50i HQ, 50p SP, 25p SP, 50i SP, 24p HQ, 24p SP, 50i, 60i) <b>Memo :</b> ● Displayed as “60i AUX” in the external input recording mode. (U model)																					
③ OK Mark	Appears when an OK mark is added. (Page 68)																					
④ Remaining Space on Media	Displays the remaining recording time of the SDHC cards in Slot A and Slot B separately. <b>Memo :</b> ● Only warnings are displayed in the STATUS 0 and STATUS 4 screens. (When the total remaining time for the SDHC cards in slot A and slot B is less than 3 minutes)  <table border="0"> <tr> <td><b>A</b></td> <td>: Currently selected slot. (White card)</td> </tr> <tr> <td><b>A!</b></td> <td>: SDHC card requires restoring or formatting, or SDHC card is not supported (not of Class 6/10 type).</td> </tr> <tr> <td><b>Aⓧ</b></td> <td>: Write-protect switch of SDHC card is set.</td> </tr> </table>		<b>A</b>	: Currently selected slot. (White card)	<b>A!</b>	: SDHC card requires restoring or formatting, or SDHC card is not supported (not of Class 6/10 type).	<b>Aⓧ</b>	: Write-protect switch of SDHC card is set.														
<b>A</b>	: Currently selected slot. (White card)																					
<b>A!</b>	: SDHC card requires restoring or formatting, or SDHC card is not supported (not of Class 6/10 type).																					
<b>Aⓧ</b>	: Write-protect switch of SDHC card is set.																					
⑤ Voltage/Battery Power	Displays the current status of the power supply in use.																					
	<table border="1"> <thead> <tr> <th>Display</th> <th>Description</th> </tr> </thead> <tbody> <tr> <td> 12.3V</td> <td>Currently powered by an AC adapter. The current voltage is shown on the right. If the supplied voltage from the AC adapter is low, the voltage value will be displayed in red as a warning.</td> </tr> <tr> <td> 12.3V  200min  30%</td> <td>Currently powered by a battery. When the battery power runs out, the battery mark appears hollow, and “RES” is displayed. The display on the right can be set using [Battery Info] of [Status Display] in the [LCD/VF] menu. (Page 91)</td> </tr> <tr> <td> RES</td> <td></td> </tr> </tbody> </table>	Display	Description	12.3V	Currently powered by an AC adapter. The current voltage is shown on the right. If the supplied voltage from the AC adapter is low, the voltage value will be displayed in red as a warning.	12.3V 200min 30%	Currently powered by a battery. When the battery power runs out, the battery mark appears hollow, and “RES” is displayed. The display on the right can be set using [Battery Info] of [Status Display] in the [LCD/VF] menu. (Page 91)	RES														
Display	Description																					
12.3V	Currently powered by an AC adapter. The current voltage is shown on the right. If the supplied voltage from the AC adapter is low, the voltage value will be displayed in red as a warning.																					
12.3V 200min 30%	Currently powered by a battery. When the battery power runs out, the battery mark appears hollow, and “RES” is displayed. The display on the right can be set using [Battery Info] of [Status Display] in the [LCD/VF] menu. (Page 91)																					
RES																						
⑥ Audio Level Meter	<table border="0"> <tr> <td></td> <td>-20 dB</td> <td></td> <td>-10 dB</td> </tr> <tr> <td>CH 1</td> <td></td> <td></td> <td></td> </tr> <tr> <td>CH 2</td> <td></td> <td></td> <td></td> </tr> <tr> <td>CH 1</td> <td></td> <td></td> <td></td> </tr> <tr> <td>CH 2</td> <td></td> <td></td> <td></td> </tr> </table>		-20 dB		-10 dB	CH 1				CH 2				CH 1				CH 2				Displays the audio level for CH-1 and CH-2. When [Rec Mode] in the [Rec Mode] menu is set to “Variable Frame”, audio cannot be recorded and is indicated by the  mark. The positions of -20 dB and -10 dB are displayed as “”. <b>Memo :</b> ● You can turn ON/OFF the display using [Audio Meter] of [Status Display] in the [LCD/VF] menu. (Page 91)
	-20 dB		-10 dB																			
CH 1																						
CH 2																						
CH 1																						
CH 2																						



# Status Screen in Camera Mode (continued)

## STATUS 2 Screen

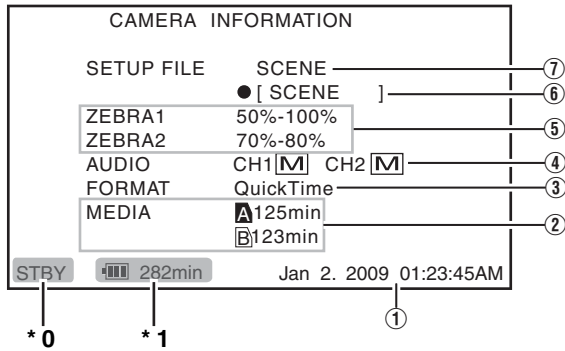

\* 0 : Same as STATUS 0 Screen (Page 102)  
 \* 1 : Same as STATUS 1 Screen (Page 104)

Item	Description
① <b>Date/Time</b>	Displays the current date and time. <b>Note :</b> <ul style="list-style-type: none"> <li>The date/time display style can be specified in [LCD/VF] menu → [Status Display] → [Date Style]/[Time Style]. (Page 91)</li> </ul>
② <b>Remaining Space on MEDIA</b>	Displays the remaining recording time of the SDHC cards in slot A and slot B separately. <b>A</b> : Currently selected slot. (White card) <b>A!</b> : SDHC card requires restoring or formatting, or SDHC card is not supported (not of Class 6/10 type). <b>A</b> : Write-protect switch of SDHC card is set.
③ <b>FORMAT</b>	Displays the file format for recording to the SDHC card (File Format) that is specified at [File Format] in the [Record Format] menu. (Page 75)
④ <b>AUDIO</b>	Displays the status of the [AUDIO SELECT CH-1/CH-2] switch. (A: "AUTO"/M: "MANUAL")
⑤ <b>ZEBRA1/ZEBRA2 Values</b>	Displays the settings from "Bottom1" to "Top1" specified at [Zebra], and the settings from "Bottom2" to "Top2" specified at [Zebra]. (Page 89) <b>Memo :</b> <ul style="list-style-type: none"> <li>When [Zebra] in the menu is set to "1Pattern", ZEBRA2 appears as "---". (Page 89)</li> </ul>
⑥ <b>Subname of Setup File</b>	Displays the subname of the setup file. <b>Memo :</b> <ul style="list-style-type: none"> <li>"●" appears at the beginning when changes are made to the loaded file. (Page 119)</li> </ul>
⑦ <b>SETUP FILE</b>	Displays the type of the loaded file. (SCENE/PICTURE)

## STATUS 3 Screen

This screen displays a list of the functions assigned to the switches.

\* 1 : (Appears only during warnings)

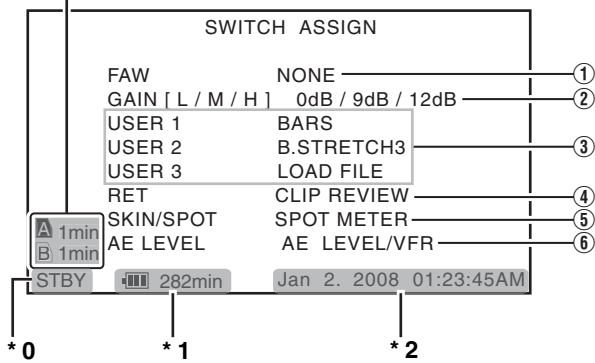

\* 0 : Same as STATUS 0 Screen (☞ Page 102)

\* 1 : Same as STATUS 1 Screen (☞ Page 104)

\* 2 : Same as STATUS 2 Screen (☞ Page 106)

Item	Description
① [FAW] Function Assignment	Displays the position of the [WHT.BAL.] selection switch that is assigned with the FAW function. (NONE, A, B, PRESET)
② [GAIN] Switch Settings	Displays the setting values for each of the positions ([L]/[M]/[H]) on the [GAIN] switch. (0dB, 3dB, 6dB, 9dB, 12dB, 15dB, 18dB, ALC)
③ [USER1,USER2,USER3] Button Function Settings	Displays the setting status of the [USER1], [USER2], and [USER3] buttons. (NONE, BARS, B.STRETCH*, B.COMPRESS*, RET, LOAD FILE) * indicates 1 to 5
④ [RET] Button Function Settings	Displays the setting status of the [RET] button on the lens. (CLIP REVIEW, RETURN, FOCUS ASSIST, OK MARK)
⑤ [SKIN AREA/SPOT METER] Switch Settings	Displays the setting status of the [SKIN AREA/SPOT METER] switch. (SKIN AREA, SPOT METER)
⑥ Cross-Shaped Button (◀▶) Function Assignment	Displays the functions assigned to the left/right (◀▶) of the cross-shaped button. (DISABLE, AE LEVEL, AE LEVEL/VFR)

## STATUS 4 Screen

This screen displays the event. It is also used to display warnings only.

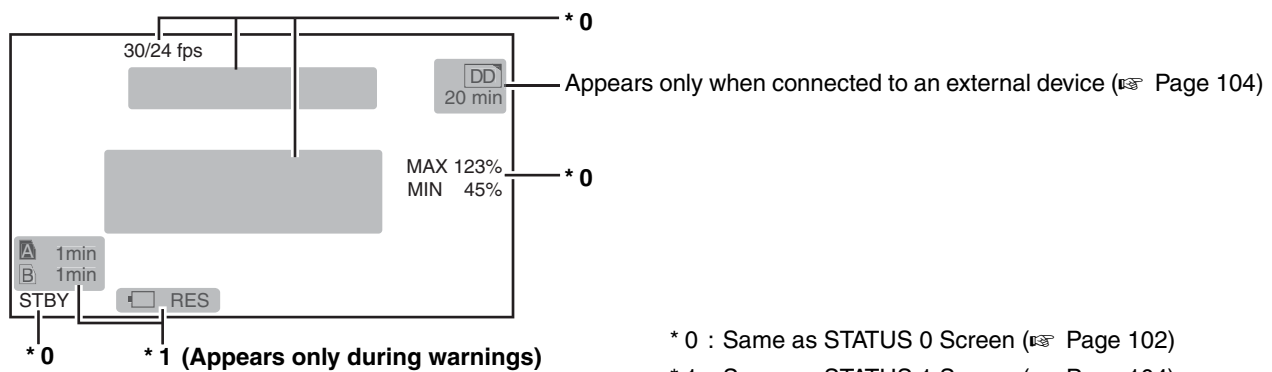

\* 0 : Same as STATUS 0 Screen (☞ Page 102)

\* 1 : Same as STATUS 1 Screen (☞ Page 104)

# Status Screen in SD Card Mode

These are the status screens displayed in Media mode (SD Card mode, Media mode).

## STATUS 0 Screen

This screen displays the media status or event. It is also used to display warnings only.

## STATUS 1 and STATUS 2 Screens

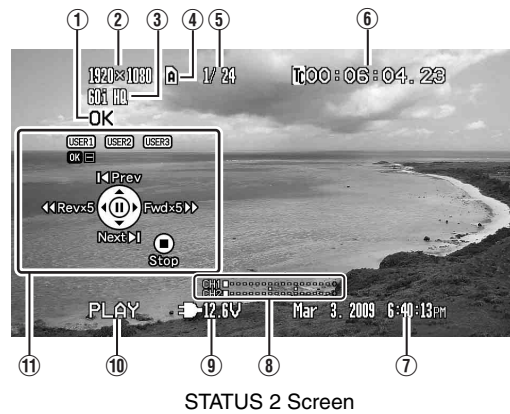
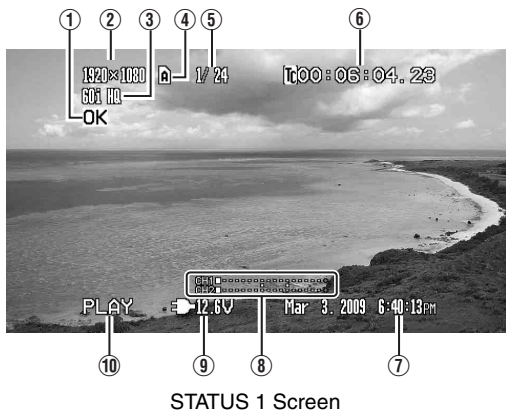

Item	Description
① OK Mark	Appears when an OK mark is added. (☞ Page 68)
② Resolution	Displays the video image resolution. (1920 × 1080, 1440 × 1080, 1280 × 720, 720 × 480, 720 × 576)
③ Frame Rate/Bit Rate	Displays the frame rate and bit rate in pairs. (60p HQ, 30p HQ, 60i HQ, 60p SP, 30p SP, 60i SP, 50p HQ, 25p HQ, 50i HQ, 50p SP, 25p SP, 50i SP, 24p HQ, 24p SP, 50i, 60i)
④ Media	Displays the media slot (A or B) of the currently played clip. A key mark appears when the write-protect switch of the SDHC card is set.
⑤ Clip Information	Displays current clip number/total number of clips.
⑥ Time Code (TC)/ User's Bit (UB)	Displays the time code (hour : minute : second : frame) or user's bit data. TC : Time code UB : User's bit The framing mode display for the time code is as follows.  <div style="display: flex; align-items: center;"> <div style="border: 1px solid black; padding: 2px; margin-right: 10px;">00:00:00:00</div> <div> <p>Colon (:) for non-drop frames</p> <p>Dot (.) for drop frames</p> </div> </div> <p><b>Memo :</b></p> <ul style="list-style-type: none"> <li>You can turn ON/OFF the display using [TC/UB] of [Status Display] in the [LCD/VF] menu. (☞ Page 91)</li> <li>You can select whether to display the time code or user's bit using the [TC DISPLAY] switch on the inner panel of the LCD monitor.</li> </ul>
⑦ Date/Time	Displays the date/time that is recorded on the currently played SDHC card.  <p><b>Note :</b></p> <ul style="list-style-type: none"> <li>The date/time display style can be specified in [LCD/VF] menu → [Status Display] → [Date Style]/[Time Style]. (☞ Page 91)</li> </ul>

Item	Description	
⑧ Audio Level Meter		Displays the audio level for CH-1 and CH-2. The positions of -20 dB and -10 dB are displayed as “■”. <b>Memo :</b> • You can turn ON/OFF the display using [Audio Meter] of [Status Display] in the [LCD/VF] menu. (☞ Page 91)
⑨ Voltage/ Battery Power	Displays the current status of the power supply in use.	
	Display	Description
	12.3V	Currently powered by an AC adapter. The current voltage is shown on the right. If the supplied voltage from the AC adapter is low, the voltage value will be displayed in red as a warning.
	12.3V 200min 30% RES	Currently powered by a battery. When the battery power runs out, the battery mark appears hollow, and “RES” is displayed. <b>Memo :</b> • The display on the right can be set using [Battery Info] of [Status Display] in the [LCD/VF] menu. (☞ Page 91)
⑩ Media Status	PLAY : Playing STILL : Still picture playback mode FWD * : High-speed playback in the forward direction (* playback speed: 5x or 15x) REV * : High-speed playback in the reverse direction (* reverse playback speed: 5x or 15x) STOP : Stop mode POFF : Power OFF	
⑪ Operation Guide	Displays a guide for the current operation buttons.	

## Status Screen in IEEE1394 Input Mode

These are the status screens displayed in Media mode (IEEE1394 Input mode).

### STATUS 1 Screen

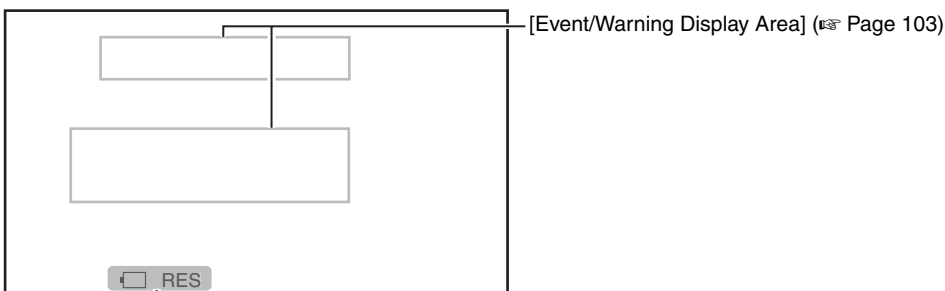





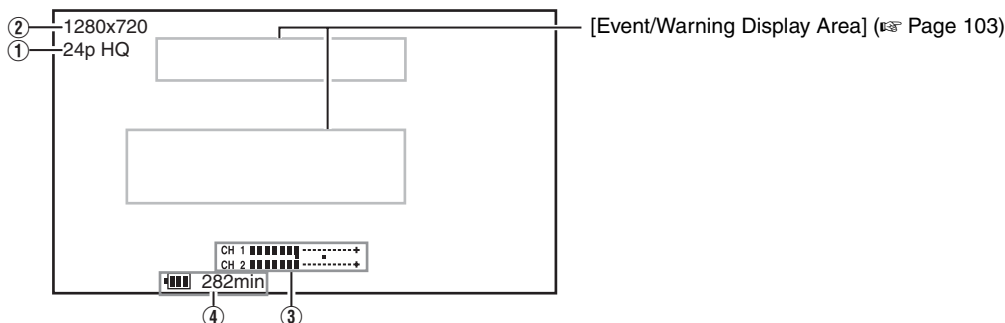



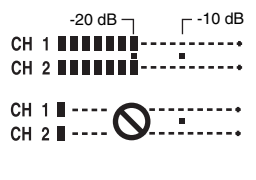







\* Appears only when a warning is displayed. [Voltage/Remaining Battery Power] (☞ Page 110)

### STATUS 2 Screen





## Status Screen in IEEE1394 Input Mode (continued)

Item	Description						
① <b>Frame Rate/Bit Rate</b>	Displays the frame rate and bit rate in pairs. (60p HQ, 30p HQ, 60i HQ, 60p SP, 30p SP, 60i SP, 50p HQ, 25p HQ, 50i HQ, 50p SP, 25p SP, 50i SP, 24p HQ, 24p SP, 50i, 60i)						
② <b>Resolution</b>	Displays the video image resolution. (1920×1080, 1440×1080, 1280×720, 720×480, 720×576)						
③ <b>Audio Level Meter</b>		Displays the audio level for CH-1 and CH-2. A  mark is displayed when the audio format is not supported in the IEEE1394 mode. (32k, 44.1k) The positions of -20 dB and -10 dB are displayed as "■". <b>Memo :</b> • You can turn ON/OFF the display using [Audio Meter] of [Status Display] in the [LCD/VF] menu. (Page 91)					
④ <b>Voltage/Remaining Battery Power</b>	Displays the current status of the power supply in use.						
	<table border="1"> <thead> <tr> <th>Display</th> <th>Description</th> </tr> </thead> <tbody> <tr> <td> 12.3V</td> <td>Currently powered by an AC adapter. The current voltage is shown on the right. If the supplied voltage from the AC adapter is low, the voltage value will be displayed in red as a warning.</td> </tr> <tr> <td> 12.3V  200min  30%  RES</td> <td>Currently powered by a battery. When the battery power runs out, the battery mark appears hollow, and "RES" is displayed. <b>Memo :</b> • The display on the right can be set using [Battery Info] of [Status Display] in the [LCD/VF] menu. (Page 91)</td> </tr> </tbody> </table>	Display	Description	 12.3V	Currently powered by an AC adapter. The current voltage is shown on the right. If the supplied voltage from the AC adapter is low, the voltage value will be displayed in red as a warning.	 12.3V  200min  30%  RES	Currently powered by a battery. When the battery power runs out, the battery mark appears hollow, and "RES" is displayed. <b>Memo :</b> • The display on the right can be set using [Battery Info] of [Status Display] in the [LCD/VF] menu. (Page 91)
Display	Description						
 12.3V	Currently powered by an AC adapter. The current voltage is shown on the right. If the supplied voltage from the AC adapter is low, the voltage value will be displayed in red as a warning.						
 12.3V  200min  30%  RES	Currently powered by a battery. When the battery power runs out, the battery mark appears hollow, and "RES" is displayed. <b>Memo :</b> • The display on the right can be set using [Battery Info] of [Status Display] in the [LCD/VF] menu. (Page 91)						



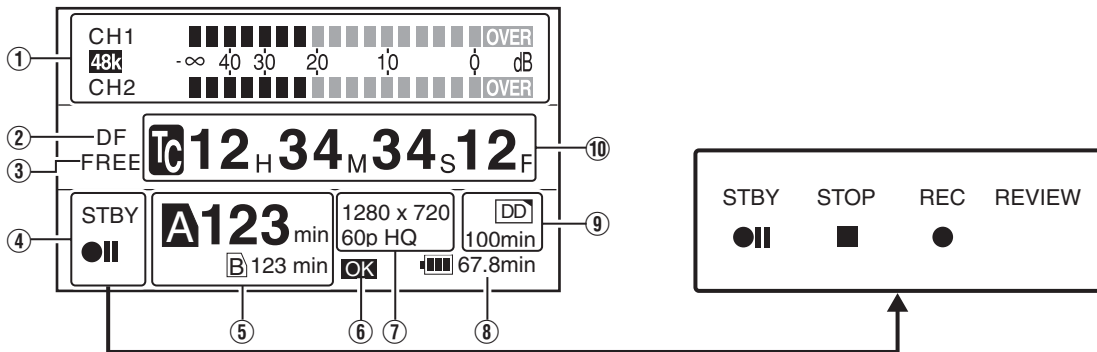

















## Enlarged Status Display on LCD Monitor

You can enlarge and display only the characters of the status screen on the LCD monitor.



Item	Description
① <b>Audio Level Meter</b>	Displays the audio levels of [CH-1] and [CH-2]. If the reference audio level (" -20dB" or " -12dB") is exceeded, this is displayed in yellow. The "Over" area is displayed in red. "48k" is the sampling frequency. <b>Memo :</b> • When [Rec Mode] in the [Rec Mode] menu is set to "Variable Frame", audio cannot be recorded and is indicated by the  mark.
② <b>Framing Mode</b>	Displays the framing mode. [DF] : Drop frame [NDF] : Non-drop frame

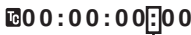

Item	Description							
③ <b>Time Code Generator</b>	Displays the operation mode of the time code. (Display: [FREE], [RECR], [REGN], [EXT], [EXT L]) (☞ Page 48) This item appears as “EXT” when [TCG Source] in the [TC/UB] menu is set to “External”.  indicates the synchronizing status of the built-in time code generator with respect to the time code that is input to the [TC IN] terminal. Lights up : During synchronization with the external time code. Light goes out : When the signal is not synchronized, or when there is no time code input.							
④ <b>Media Status</b>	Displays the SDHC card status in characters and symbols. ---- : No card found in the selected slot STBY : Recording standby (recording pause) REC : Recording REVIEW : Clip Review (☞ Page 56) STBY  : Pre Rec recording standby (☞ Page 58) REC  : Pre Rec recording (☞ Page 58) STBY  : Clip Continuous recording standby (☞ Page 59) REC  : Clip Continuous recording (☞ Page 59) STBY  (displayed in yellow) : Clip Continuous recording pause (☞ Page 59) STOP : Unable to record to the card in the slot POFF : Power OFF							
⑤ <b>Remaining Space on Media</b>	Displays the remaining recording time on the SDHC card. The currently active slot is indicated using an enlarged card icon with black characters and a white background. A key mark appears when the write-protect switch of the SDHC card is set.							
⑥ <b>OK Mark</b>	Appears as [OK] when the currently played clip is appended with an OK mark.							
⑦ <b>Video Format</b>	Displays the video format that is set. (☞ Page 38) <b>Memo :</b> _____ • Displayed as “60i AUX” in the external input recording mode. (U model)							
⑧ <b>Voltage/ Battery Power</b>	<table border="1" data-bbox="416 864 1485 1200"> <thead> <tr> <th data-bbox="416 864 624 931">Display</th> <th data-bbox="624 864 1485 931">Description</th> </tr> </thead> <tbody> <tr> <td data-bbox="416 931 624 1021"> 12.3V</td> <td data-bbox="624 931 1485 1021">Currently powered by an AC adapter. The current voltage is shown on the right. If the supplied voltage from the AC adapter is low, the voltage value will be displayed in red as a warning.</td> </tr> <tr> <td data-bbox="416 1021 624 1200">  12.3V   200min   30%   RES         </td> <td data-bbox="624 1021 1485 1200">           Currently powered by a battery.            When the battery power runs out, the battery mark appears hollow, and “RES” is displayed.  <b>Memo :</b> _____            • The display on the right can be set using [Battery Info] of [Status Display] in the [LCD/VF] menu. (☞ Page 91)         </td> </tr> </tbody> </table>		Display	Description	 12.3V	Currently powered by an AC adapter. The current voltage is shown on the right. If the supplied voltage from the AC adapter is low, the voltage value will be displayed in red as a warning.	 12.3V  200min  30%  RES	Currently powered by a battery. When the battery power runs out, the battery mark appears hollow, and “RES” is displayed. <b>Memo :</b> _____ • The display on the right can be set using [Battery Info] of [Status Display] in the [LCD/VF] menu. (☞ Page 91)
Display	Description							
 12.3V	Currently powered by an AC adapter. The current voltage is shown on the right. If the supplied voltage from the AC adapter is low, the voltage value will be displayed in red as a warning.							
 12.3V  200min  30%  RES	Currently powered by a battery. When the battery power runs out, the battery mark appears hollow, and “RES” is displayed. <b>Memo :</b> _____ • The display on the right can be set using [Battery Info] of [Status Display] in the [LCD/VF] menu. (☞ Page 91)							
⑨ <b>Operation of External Device</b>	Displays the operating status of the connected external device. For details, refer to the instruction manual of the corresponding external device.							
⑩ <b>Time Code (TC)/ User's Bit (UB)</b>	Displays the time code (hour : minute : second : frame) or user's bit data.  00:00:00:00 Colon (:) for non-drop frames Dot (.) for drop frames							

**Memo :** \_\_\_\_\_  
 • During enlarged display of the status on the LCD monitor screen, the video image remains displayed on the viewfinder.

## Marker and Safety Zone Displays (Camera Mode Only, Excluding AUX Mode)

The marker and safety zone displays are useful in helping you determine the angle of view for the image according to the shooting purpose.

■ Example of display when [Aspect Ratio] = “4:3”, [Aspect Marker] = “Line+Halftone”, and [Center Mark] = “On”

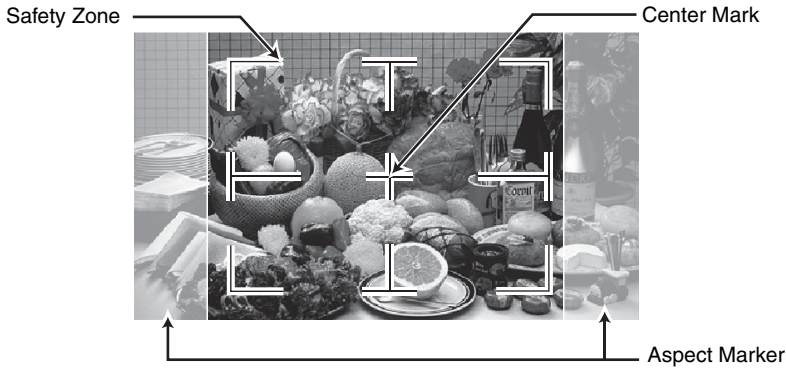

You can turn ON/OFF the safety zone and center mark displays as shown below using the [Aspect Ratio], [Safety Zone] and [Center Mark] settings of [Marker Setting] in the [LCD/VF] menu. (☞ Page 90)

### [Aspect Marker] Display

■ When [Aspect Ratio] = “4:3”

[Line]	[Halftone]	[Line+Halftone]





### [Aspect Marker] Display for Different [Aspect Ratio] Settings

■ When [Aspect Marker] = “Halftone”

[4:3]	[14:9]	[16:9]/[16:9 (+4:3)]	[2.35:1 Center]	[2.35:1C.HeadRM]
[1.85:1 Center]	[1.85:1C.HeadRM]	[1.66:1]	[1.75:1]	

### [Safety Zone] Display

■ When [Aspect Ratio] = "4:3", [Aspect Marker] = "Halftone", and [Center Mark] = "On"

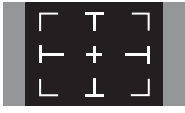
[Off]	[95%]	[93%]	[90%]	[88%]
				
<b>[80%]</b>				
				

### [Center Mark] Display

■ When [Aspect Ratio] = "4:3", [Aspect Marker] = "Halftone", and [Safety Zone] = "80%"

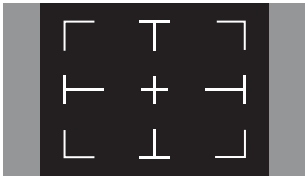
[Off]	[On]
	

■ When [Aspect Ratio] = "4:3", [Aspect Marker] = "Halftone", and [Safety Zone] = "Off"

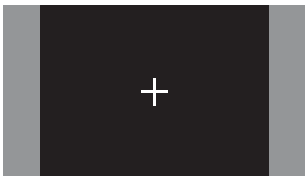
[Off]	[On]
	

## Smoothing the Skin Color (Skin Detail Function)

The Skin Detail function can be used to reduce the contour enhancement of video signals for only the skin areas so as to produce a smoother skin tone.

### Preparations Before Using the Skin Detail Function (Skin Adjust Function)

- 1 Adjust the white balance. (☞ Page 42)
- 2 Display the [Skin Color Adjust] screen. (☞ Page 84)
  - Select [Main Menu] screen → [Camera Process] menu → [Detail]/[Adjust] → [Skin Color Adjust], and press the Set button (●).
  - The entire image switches to black-and-white display, leaving only the detected skin areas in color.



- Memo :**
- The displays for [Bars], [Zebra] and [Focus Assist] are temporarily set to "Off", while the [B & W] display in [VF Display] temporarily switches to "Color".

### Hue Range Detection

1 Project the detected object inside the skin color detection frame.

2 Place the cursor at [Skin Color Detect] with the cross-shaped button (▲▼).

3 Press the Set button (●).

Display switches from "Stop" to "Execute", and detection starts.

- Memo :**
- "Error" is displayed if the object inside the frame is not within the preset color range.

4 Press the Set button (●) after the desired hue range is detected.

- If no "Error" is displayed, the data is saved and the process ends.
- If "Error" appears, the process ends without saving the data.

5 Place the cursor at [Back] after the hue range is detected, and press the Set button (●).

Returns to the [Detail] menu screen.

### Color Range Setting

1 Place the cursor at [Skin Color Range] with the cross-shaped button (▲▼).

2 Press the Set button (●) or cross-shaped button (▶) to move the cursor to a setting value.



3 Select a setting value using the cross-shaped button (▲▼), and press the Set button (●).

Select a setting within the [Narrow, -1 to -9, Normal, 9 to 1, Wide] range.

4 Place the cursor at [Back] after setting is complete, and press the Set button (●).

The data is saved, and the screen returns to the [Detail] menu.

### Using the Skin Detail Function

1 Set [Skin Detect] to "On". (☞ Page 84)

- Select [Main Menu] screen → [Camera Process] menu → [Detail]/[Adjust] → [Skin Detect] and set to "On".
- "S.DTL" appears on the STATUS 0 and 1 screens of the LCD monitor and viewfinder when the Skin Detail function is activated.

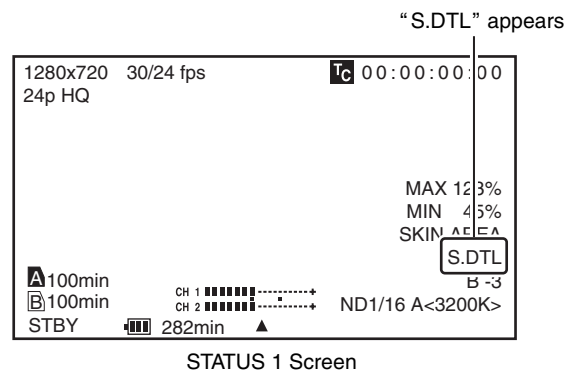

2 Set the adjustment level for the contour enhancement of the skin tone. (☞ Page 84)

Set using [Main Menu] screen → [Camera Process] menu → [Detail]/[Adjust] → [Skin Color Detect]/[Level].

## Checking the Preset Hue Area

**1** Set the [ZEBRA ON/OFF] switch at the front of the camera recorder to the [SKIN AREA/SPOT METER] end.

Doing so forcibly turns ON the Skin Adjust function temporarily, and the preset hue area is displayed in color on the LCD monitor and viewfinder.

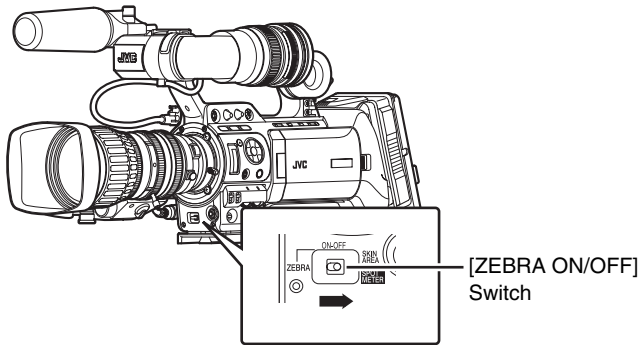

### Memo :

- When [Color Gain] in the [Camera Process] menu is set to “Off”, only the area where Skin Detail is functioning is displayed in skin tone. (☞ Page 83)
- When [SKIN A./SPOT M.] of [Switch Set] in the [Camera Function] menu screen is set to “Spot Meter”, the hue area cannot be checked using the [SKIN AREA/SPOT METER] switch. (☞ Page 80)

## Color Bar Output

Multi-format color bars can be output on this camera recorder.

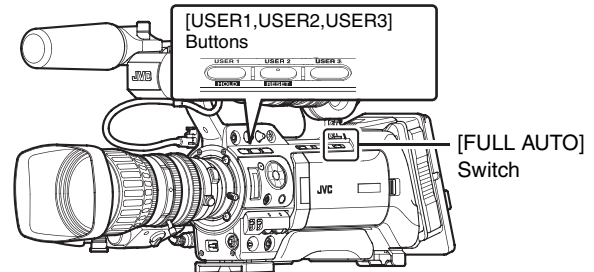

### Setting

To output color bars, follow the setting procedure below.

- 1** Set the [FULL AUTO] switch to “OFF”.
- 2** Set [Bars] in the [Camera Function] menu to “On”. (☞ Page 78)

Color bars are output.

### Color Bar Output Using the USER Buttons

- 1** Set the [FULL AUTO] switch to “OFF”.
- 2** Assign “Bars” to any one of the [USER1]/[USER2]/[USER3] buttons.  
Set using [USER1]/[USER2]/[USER3] of [Switch Set] in the [Camera Function] menu. (☞ Page 79)
- 3** Press the corresponding [USER1]/[USER2]/[USER3] button that is assigned with “Bars”.

Color bars are output.

### Memo :

- During color bar output, you can select whether to output the reference audio signals using [Test Tone] in the [Audio Set] menu. (☞ Page 77)
- When the [FULL AUTO] switch is set to “ON” and [Bars] in the [FULL AUTO] menu is set to “Off”, color bars are not output in the AUX and Media modes.

# Color Matrix Adjustment

The color matrix of the camera recorder can be adjusted to a color of the user's preference.

When shooting is performed using multiple cameras, the colors of the different cameras can be adjusted, and a color of the user's preference can be set on this camera recorder. 13 saturation parameters and 3 hue parameters are available for adjustment. Adjust the color on the vector scope and waveform monitor using the color chart.

\* The adjusted values of "Standard", "Cinema Vivid", and "Cinema Subdued" in [Color Matrix] can be stored individually. (☞ Page 83)

**1** Select [Color Matrix] or [Adjust] in the [Camera Process] menu. (☞ Page 86)

**2** Adjust the saturation.

- Use the cross-shaped button (▲▼) to select a value.
- The correction range (gray area in the chart below) for each of the 12 levels from [Mg&R Mg Level] to [B&Mg Mg Level] changes in the direction indicated by the arrow on the vector scope.

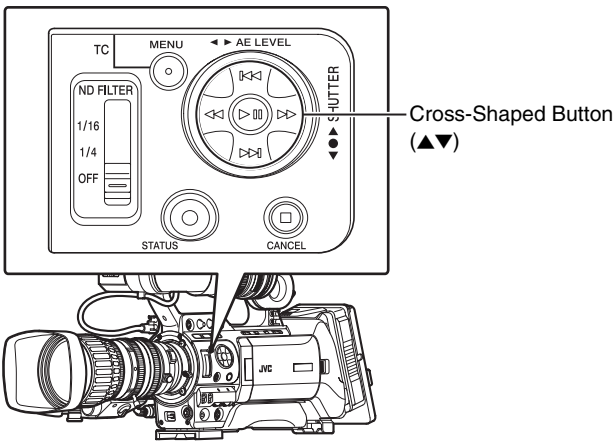

**Memo :**

- In addition to the vector, the luminance Y level of the correction range changes as well.

<b>Mg&amp;R Mg Level</b>		Increase the value: Corrected Y decreases  Decrease the value: Corrected Y increases
<b>Mg&amp;R R Level</b>		Increase the value: Corrected Y increases  Decrease the value: Corrected Y decreases

<b>R&amp;YI R Level</b>		Increase the value: Corrected Y increases  Decrease the value: Corrected Y decreases
<b>R&amp;YI YI Level</b>		Increase the value: Corrected Y decreases  Decrease the value: Corrected Y increases
<b>YI&amp;G YI Level</b>		Increase the value: Corrected Y decreases  Decrease the value: Corrected Y increases
<b>YI&amp;G G Level</b>		Increase the value: Corrected Y increases  Decrease the value: Corrected Y decreases
<b>G&amp;Cy G Level</b>		Increase the value: Corrected Y increases  Decrease the value: Corrected Y decreases
<b>G&amp;Cy Cy Level</b>		Increase the value: Corrected Y decreases  Decrease the value: Corrected Y increases
<b>Cy&amp;B Cy Level</b>		Increase the value: Corrected Y decreases  Decrease the value: Corrected Y increases
<b>Cy&amp;B B Level</b>		Increase the value: Corrected Y increases  Decrease the value: Corrected Y decreases

<b>B&amp;Mg B Level</b>		<p>Increase the value: Corrected Y increases</p> <p>Decrease the value: Corrected Y decreases</p>
<b>B&amp;Mg Mg Level</b>		<p>Increase the value: Corrected Y decreases</p> <p>Decrease the value: Corrected Y increases</p>

### 3 Adjust YI&G Mask Range.

Adjusting [YI&G YI Level] and [YI&G G Level] may also affect the I-axis (color close to the skin tone). When [YI&G YI Level] is increased, the skin tone becomes slightly more yellowish. On the other hand, when [YI&G G Level] is increased, the skin tone becomes slightly more greenish.

Adjust [YI&G Mask Range] if you want to increase YI&G toward yellow and green without affecting the skin tone. As illustrated in the chart below, [YI&G Mask Range] adjusts the gray area from the R-axis, which disables the [YI&G YI Level] and [YI&G G Level] adjustments.

Increasing the [YI&G Mask Range] value widens the masking range. By doing so, the effect on the I-axis (color close to the skin tone) due to adjustments of [YI&G YI Level] and [YI&G G Level] is reduced. However, this also reduces the amount of correction by [YI&G YI Level] and [YI&G G Level].

<b>YI&amp;G Mask Range</b>	<p>[YI&amp;G YI Level] and [YI&amp;G G Level] adjustment</p>
----------------------------	--

### 4 Adjust the hue.

Adjust the hue based on the R-, G-, and B-axes.

As illustrated in the chart below, increasing the value rotates the hue in the anti-clockwise direction on the vector scope, with the respective axes as the center. Decreasing the value rotates the hue in the clockwise direction.

<b>R Rotation</b>		<p>Increase the value: Hue rotates in the anti-clockwise direction with R-axis as the center.</p>
<b>G Rotation</b>		<p>Increase the value: Hue rotates in the anti-clockwise direction with G-axis as the center.</p>
<b>B Rotation</b>		<p>Increase the value: Hue rotates in the anti-clockwise direction with B-axis as the center.</p>



## Reproduction of Dark Areas (Black Stretch/Compress Function)

Process the dark areas according to the balance of bright and dark areas in the image to adjust the overall balance of contrast.

**1** Adjust [Black Toe] in the [Camera Process] menu according to the captured video signals.

**2** Set the luminance point (Point Level) for “Stretch” or “Compress”.

- Decide the luminance point (Point Level) at which the dark areas in the image are to be stretched or compressed.
- The luminance point (Point Level) can be set within the range of “5% to 15%”.

**3** Adjust the amount of “Stretch” or “Compress”.

- Set the amount to stretch or compress the dark areas in the image using [Stretch Level] or [Compress Level].
- The amount of stretch or compression increases when a larger value is specified.

### ■ Example

To increase the area of 10 % level (Point A in the figure below) in the image under normal condition ([Black Toe] is “Normal”)

- ① Set [Black Toe] to “Stretch”.
- ② Set [Point Level] to “10%”.
- ③ Set the amount to increase using [Stretch Level] (“Level 1 to Level 5”).

The reproduction of dark areas improves as the 10 % level point A stretches toward point B. (See figure below)

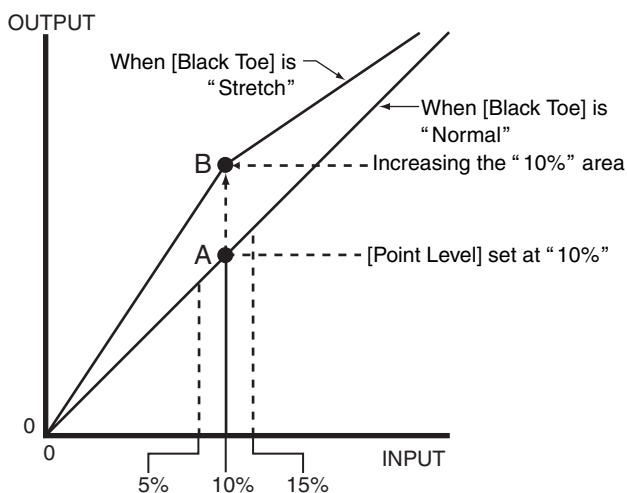

# Configuring Setup Files

The menu settings can be stored on the camera recorder or an SDHC card by saving them as a setup file.

Loading a saved setup file enables you to reproduce the appropriate setup state speedily.

Two types of setup files are available.

## ■ Scene file:

File that contains all menu settings, ranging from video format settings to image creation settings such as device settings and shooting conditions, as well as the contents of the [Favorites Menu].

## ■ Picture file:

File that contains image creation settings in accordance to the shooting conditions ([Camera Process] menu items).  
(☞ Page 82)

Make use of the [Setup File Manage] menu to save or load a setup file.

The following operations can be performed on the [Setup File Manage] menu.

- Saving setup files (☞ Page 120)
- Loading a setup file (☞ Page 121)
- Resetting a saved file (☞ Page 121)

## ■ Number of Storable Setup Files

Camera recorder	: [CAM1] ~ [CAM4]
SDHC Card	
Slot A	: A[EXT1] ~ A[EXT8]
Slot B	: B[EXT1] ~ B[EXT8]

## ■ Preset Setup Files

As described below, there are three types of scene files and two types of picture files that can be loaded according to different shooting conditions.

### Scene file

[GY-HD 60p LIKE]	: Setting is adjusted according to the tone of the GY-HD series. [Camera Resolution] is set to "1280x720", and [Frame & Bit Rate] is set to "60p (HQ)".
[GY-HD 50p LIKE]	: Setting is adjusted according to the tone of the GY-HD series. [Camera Resolution] is set to "1280x720", and [Frame & Bit Rate] is set to "50p (HQ)".
[CINEMA 1080/24p]	: Setting that is suited for movie-like video shooting. [Camera Resolution] is set to "1920x1080", and [Frame & Bit Rate] is set to "24p (HQ)".

### Picture file

[GY-HD LIKE]	: Setting is adjusted according to the tone of the GY-HD series.
[CINEMA]	: Setting that is suited for movie-like video shooting.

### Memo :

- The above setup files are used exclusively for loading. They cannot be overwritten or reset.

## ■ Compatibility

### Scene file

- Scene files saved using the GY-HM700 series cannot be loaded using this camera recorder.
- Scene files saved using this camera recorder cannot be loaded using the GY-HM700 series.

### Picture file

- Picture files saved using the GY-HM700 series can be loaded using this camera recorder. When the [Alternative Temp.] setting is not available on the GY-HM700 series, it is set to the default value.
- JVC does not provide guarantee that picture files saved using this camera recorder can be loaded using the GY-HM700 series.

# Configuring Setup Files (continued)

## Saving Setup Files

### 1 Display the [Setup File Manage] menu.

Select the [Setup File Manage] menu on the [Main Menu] screen, and press the Set button (●). (Page 97)

### 2 Select [Store File] and press the Set button (●).

### 3 Select [Scene File] or [Picture File], and press the Set button (●).

The existing files are displayed.

### 4 Select the file to be newly saved (or overwritten) using the cross-shaped button (▲▼), and press the Set button (●).

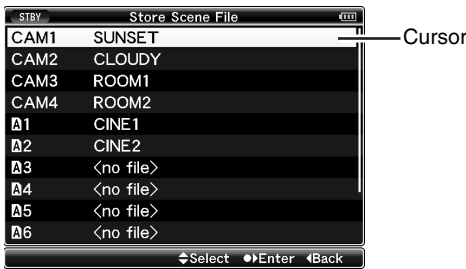

[Store File] Menu Screen

**Memo :**

- Files cannot be written in the following cases. (Displayed in gray, selection disabled)
  - The inserted SDHC card is not supported (those other than SDHC Class 6/10 cards, or unformatted cards). (File name appears as “---”.)
  - When a write-protected SDHC card is inserted (a lock mark appears beside the SDHC card icon.)

### 5 Name the file.

Enter the subname using the software keyboard.

■ Operating instructions of software keyboard (Page 71)

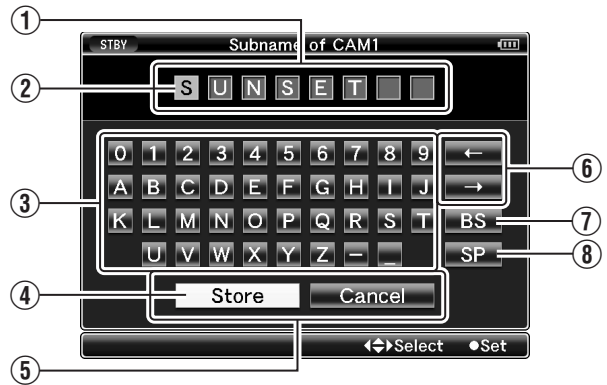

**Memo :**

- When overwriting an existing file, the subname of the existing file is displayed.
- Select [Cancel] and press the Set button (●), or press the [CANCEL] button to return to the previous screen.

Name	Description
① Character Entry Field	Field for entering the title. You can enter up to 8 characters for the [Scene File]/[Picture File] subname.
② Character Cursor	Select a character using the key cursor ④, and press the Set button (●) to input the selected character at the position of the character cursor. The character cursor moves to the next position on the right each time a character is input. The cursor can be moved using the arrow keys ⑥.
③ Character Keys	Use the cross-shaped button (▲▼◀▶) to move the key cursor ④ to the character you want to enter.
④ Key Cursor	Indicates the currently selected character or item. Use the cross-shaped button (▲▼◀▶) to move the cursor.
⑤ Confirmation Buttons	Select [Store] and press the Set button (●) to confirm the title. Select [Cancel] and press the Set button (●) to abort character input and return to the previous screen.
⑥ Arrow Keys	Moves the position of the character cursor ②.
⑦ [BS] Backspace Key	Select [BS] and press the Set button (●) to delete the character on the left of the character cursor ②.
⑧ [SP] Space Key	Select [SP] and press the Set button (●) to enter a space at the current position of the character cursor ②.

### 6 Select [Store] from the confirmation buttons ⑤, and press the Set button (●).

A confirmation screen appears.

### 7 Select [Store] on the confirmation screen, and press the Set button (●).

Saving starts, and “Storing...” appears on the screen.

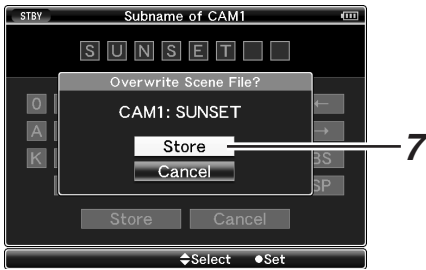

**Memo :**

- If you do not want to save the file, select [Cancel] or press the [CANCEL] button to return to the previous screen.
- When saving of a file fails, a “Store Error!” message (indicated in red frame) appears for several seconds, after which the previous screen is displayed.

**8 Saving is complete.**

After saving of the file is complete, “Complete” appears on the screen, and the menu screen closes automatically.

**Loading a Setup File**

**1 Display the [Setup File Manage] menu.**

Select the [Setup File Manage] menu on the [Main Menu] screen, and press the Set button (●). (☞ Page 97)

**2 Select [Load File] and press the Set button (●).**

**3 Select [Scene File] or [Picture File], and press the Set button (●).**

The existing files are displayed.

**4 Select the file to load using the cross-shaped button (▲▼), and press the Set button (●).**

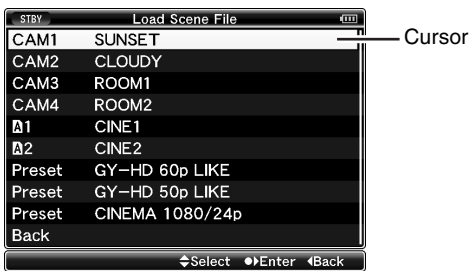

[Load File] Menu Screen

**Memo :**

- When the write-protect switch of the inserted SDHC card is set, a mark appears beside the SDHC card icon. Setup files can be loaded from an SDHC card even if the write-protect switch is set.
- A mark is displayed at the right end when there are some settings that are not supported by the setup file (e.g., picture files saved using the GY-HM700 series). These files can be loaded by this camera recorder, but some of the settings will not be compatible. (☞ Page 119)
- Setup files that are completely incompatible will not be displayed. (☞ Page 119)

**5 Select [Load] on the confirmation screen, and press the Set button (●).**

Loading starts, and “Loading...” appears on the screen.

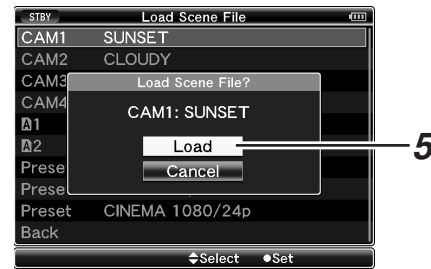

**Memo :**

- If you do not want to load the file, select [Cancel] or press the [CANCEL] button to return to the previous screen.
- When loading of a file fails, a “Load Error!” message (indicated in red frame) appears for several seconds, after which the previous screen is displayed.

**6 Loading is complete.**

After loading of the file is complete, “Complete” appears on the screen, and the menu screen closes automatically.

**Resetting Setup Files**

**1 Display the [Setup File Manage] menu.**

Select the [Setup File Manage] menu on the [Main Menu] screen, and press the Set button (●). (☞ Page 97)

**2 Select [Reset File] and press the Set button (●).**

**3 Select [Scene File] or [Picture File], and press the Set button (●).**

The existing files are displayed.

**4 Select the file to delete using the cross-shaped button (▲▼), and press the Set button (●).**

**Memo :**

- Scene files and preset scene files stored inside the SDHC card cannot be selected or reset.

**5 Select [Reset] on the confirmation screen, and press the Set button (●).**

Deletion starts, and “Resetting...” appears on the screen.

**Memo :**

- If you do not want to reset the file, select [Cancel] or press the [CANCEL] button to return to the previous screen.

**6 Resetting is complete.**

After resetting of the file is complete, “Complete” appears on the screen, and the menu screen closes automatically.

## Connecting an External Monitor

To output live or playback video images and audio sound to an external monitor, select the output signals from the camera recorder, and connect using an appropriate cable according to the monitor to be used.

### Connecting via Composite/Component Output

Either component or composite signals can be output from the BNC terminals on the terminal area of the camera recorder. Connect the external monitor to the [Y/VIDEO] output terminal for composite signals, or to [Y/VIDEO], [PB], and [PR] video signal output terminals for component signals.

- \* Select the output signal using [Output Terminal] in the [A/V Out] menu. (☞ Page 92)
- \* To display menu screens or status screens on the external monitor, set [Analog Out Char.] in the [A/V Out] menu to "On". (☞ Page 92)

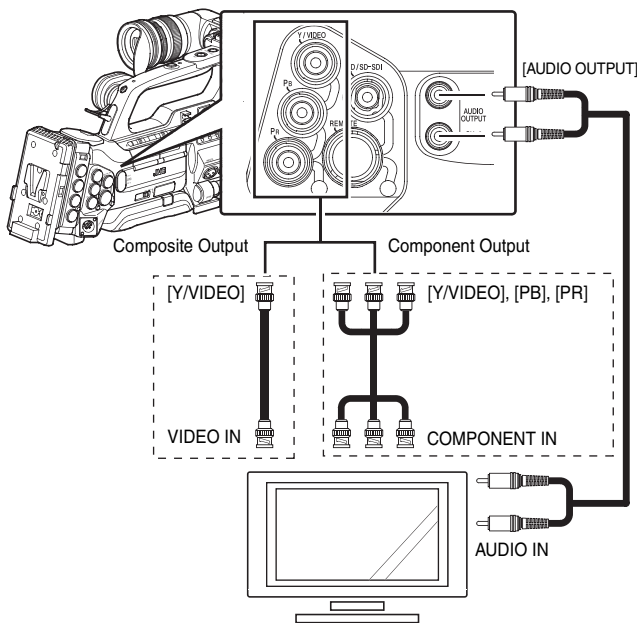

### Settings for Composite Output

#### 1 Down convert the signals.

You can select the method to "down convert" HD video images to SD images during composite output. Set using [Down Convert] in the [A/V Out] menu. The available modes include "Side Cut", "Letter Box" (blackened at the top and bottom), and "Squeeze" (full size, compressed at the left and right). (☞ Page 92)

#### Memo :

- When [System Definition] in the [Record Format] menu is set to "SD (DV)", selection cannot be made. (☞ Page 75)

#### 2 Add setup signals.

Setup signals can be added to the output video signals during composite output.

- \* You can select whether to add setup signals using [Set Up] in the [A/V Out] menu. (☞ Page 92)

### Connecting via SDI

Either HD-SDI or SD-SDI signals can be output from the [HD/SD-SDI] terminal (BNC) on the terminal area of the camera recorder.

- Digital video signals, together with embedded (superimposed) audio signals and time code signals, are output for both the HD-SDI and SD-SDI signals.
- User's bit output from the [HD/SD-SDI] output terminal is used as a flag to determine valid video signals. Therefore, accurate values will not be output.

#### Memo :

- The sampling frequency for embedded (superimposed) audio signals is 48 kHz. Time code of the built-in time generator as well as playback time code are also output.

- \* Select the output signal using [HD/SD-SDI Out] in the [A/V Out] menu. (☞ Page 92)
- \* When [System Definition] in the [Record Format] menu is set to "SD (DV)", only SD-SDI signals are output. (☞ Page 75)
- \* To display menu screens or status screens on the external monitor, set [SDI Out Char.] in the [A/V Out] menu to "On". (☞ Page 92)

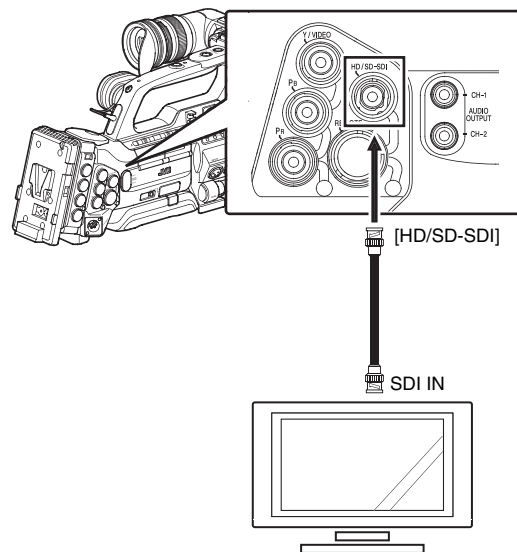

### Settings for SDI Output

#### 1 Down convert the signals.

You can select the method to "down convert" HD video images to SD images during SD-SDI output. Set using [Down Convert] in the [A/V Out] menu. The available modes include "Side Cut", "Letter Box" (blackened at the top and bottom), and "Squeeze" (full size, compressed at the left and right). (☞ Page 92)

#### Memo :

- When [System Definition] in the [Record Format] menu is set to "SD (DV)", selection cannot be made. (☞ Page 75)

## [PHONES] Terminal

Audio output from the [PHONES] terminal can be selected using [Audio Monitor] in the [A/V Out] menu (☞ Page 93) as well as the [MONITOR SELECT] switch on the camera recorder.

The different combinations of settings that are output from the [PHONES] terminal and monitor speaker are as follows.

[MONITOR SELECT] Switch Settings	[Audio Monitor] Settings	[PHONES] Terminal		Speaker
		L	R	
[CH-1]	—	CH1		CH1
[BOTH]	[Mix]	CH1+CH2		CH1+CH2
	[Stereo]	CH1	CH2	
[CH-2]	—	CH2		CH2

## IEEE1394 Connection

“Backup recording” can be performed, which allows the same image recorded to the SDHC card on the camera recorder to be recorded to the external device connected to the IEEE1394 terminal. (☞ Page 124)

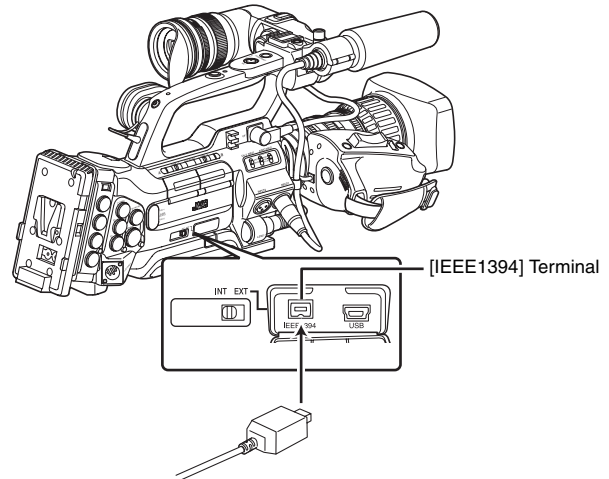

### Note :

- When connecting the camera recorder to an external device using an IEEE1394 cable, make sure to observe the following. Improper connection may cause the circuit of the connected unit to malfunction.
  - Turn off the power of the camera recorder and connected devices before connecting the IEEE1394 cable.
  - Do not connect the cable in an environment where static electricity occurs or is likely to occur.
  - Make sure that each camera recorder is connected to only one external device at any one time.
- When the video format input from the [IEEE1394] terminal is different from the video format of the camera recorder, a “VIDEO FORMAT INCORRECT” message is displayed. Set according to the video format entered for [System Definition], [Camera Resolution], and [Frame & Bit Rate] in the [Record Format] menu. (☞ Page 75)

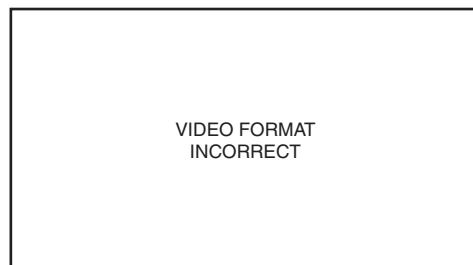

- If the [INT/EXT] IEEE1394 interface terminal switch is set at “EXT” and the “HQ” mode is selected in [Frame & Bit Rate], signals will not be output from the [IEEE1394] terminal. (☞ Page 75)

## IEEE1394 Connection (continued)

### Backup Recording

When the camera recorder is set to Camera mode, images shot using it can be stream output from the IEEE1394 terminal.

According to the recording operation on the camera recorder, recording to the camera recorder and external device may be performed synchronously or separately.

#### 1 Connect the camera recorder to the backup device.

Connect the camera recorder to the backup device using an IEEE1394 cable, using the camera recorder as the master device.

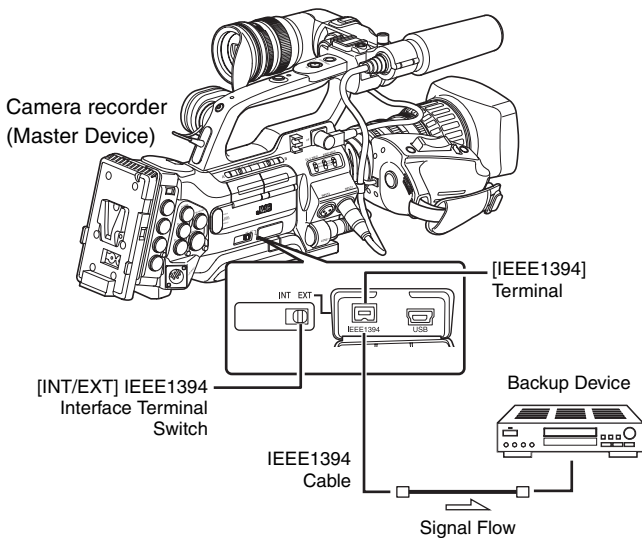

#### 2 Set the camera recorder to Camera mode.

#### 3 Set the recording video format.

Perform setting in the [Record Format] menu. Select a video format in [System Definition]. (☞ Page 75)

[HD (MPEG2)] : Performs backup in the HDV format.

[SD (DV)] : Performs backup in the DV format.

#### Note :

- To back up in the HDV format, be sure to select SP mode for the [Frame & Bit Rate] setting.

#### 4 Perform the following settings on the camera recorder (master device).

- ① Set the [INT/EXT] IEEE1394 interface terminal switch to "EXT".
- ② Switch to Camera mode.
- ③ Specify how recording to the camera recorder and external device is to be performed with the recording operation on the camera recorder using [1394 Rec Trigger] in the [Others] menu. (☞ Page 94)

#### 5 Set the external device to a mode that enables recording.

For setting and operation of external devices, refer to the instruction manual of the respective devices.

#### Note :

- Adjust the camera recorder and external device to the same IEEE1394 settings.
- Start recording only after ensuring that the devices are properly connected.

#### 6 Perform recording using the camera recorder.

If the settings in 3 are appropriate, video images will be recorded to the camera recorder and external device.

#### Note :

- Images, audio and time code at the points where recording starts and ends may be out of sync depending on the camera recorder and backup device in use.

#### Memo :

- When backup recording starts, a "TRIGGER TO EXT" message appears on the LCD monitor and viewfinder for about 3 seconds.

## ■ Checking Videos Recorded on the External Device

### (IEEE1394 Input mode of Media mode)

When images are displayed in thumbnails in Media mode (SD Card mode) and power of the device connected to the [IEEE1394] terminal is turned on, pressing the [CAM/MEDIA] selection button displays the playback images of the connected device on the LCD monitor and viewfinder. (Only for HD video systems)

Pressing the same button has no effect if the [IEEE1394] connection is not recognized, such as when the power of the device connected to the [IEEE1394] terminal is turned off. When an SD video system is in use, availability of the [IEEE1394] terminal connection cannot be detected in Media mode (SD Card mode). Allow the camera recorder to detect the [IEEE1394] terminal connection in advance by turning on the power of the connected equipment in Camera mode. Refer to [Status Screen in IEEE1394 Input Mode] (☞ Page 109) for the status display of this mode.

#### 1 Set the [Record Format] menu according to the input video format. (☞ Page 75)

#### 2 Press the [CAM/MEDIA] button to set to the IEEE1394 Input mode.

#### 3 Set the external device to the playback mode.

Video images recorded on the external device are displayed on the LCD monitor and viewfinder.

#### Note :

- This mode is used for viewing images input to the [IEEE1394] terminal from an external device, and not intended for recording input images on the camera recorder.



## Input of Composite Video Signals from External Device (GY-HM790CHU/GY-HM790U only)

This camera recorder is equipped with an AUX input terminal on the side for recording composite video signals from an external device to an SDHC card.

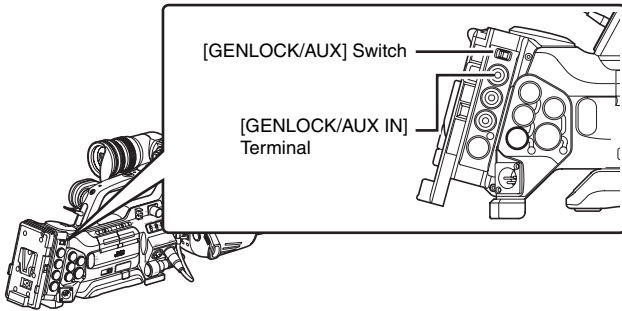

**Memo :**

- [Favorites Menu] does not function in AUX mode.

**1** Set the camera recorder to Camera mode.

**2** Set the [GENLOCK/AUX] switch to "AUX".

The [Record Format] menu settings are as follows. (☞ Page 75)

[System Definition] Item	: SD (DV)
[Camera Resolution] Item	: 720 x 480
[Frame Rate] Item	: 60i

**3** Set the following items in the [Record Format] menu. (☞ Page 75)

- Select the format for recording to the SDHC card in [File Format] ("QuickTime" or "AVI").
- Set the [Aspect Ratio].

"16:9" : When the input analog signal is a squeeze signal

"4:3" : All cases other than that stated above

**4** Set [Set Up] in the [A/V Out] menu. (☞ Page 92)

"7.5%" : When input analog signals include setup signals

"0.0%" : When input analog signals do not include setup signals

**5** Input composite video signals from the external device to the [GENLOCK INPUT] terminal.

**Note :**

- Input jitter-free composite video signals.  
Input level : 1.0 ± 0.3 V (p-p)

**6** Start/Stop recording using the [REC] button on the camera recorder.

The EE image of the input signal is output in the SD (DV) format from the respective video output terminals.

**Note :**

- During recording of external video signals, checking of the recording (Clip Review) cannot be performed using the [RET] button on the lens.
- Do not touch the [GENLOCK/AUX] switch while recording is in progress.

### ■ Status Screen Display in AUX Mode

In the AUX mode, "AUX" is displayed on the status screens of the LCD monitor and viewfinder.

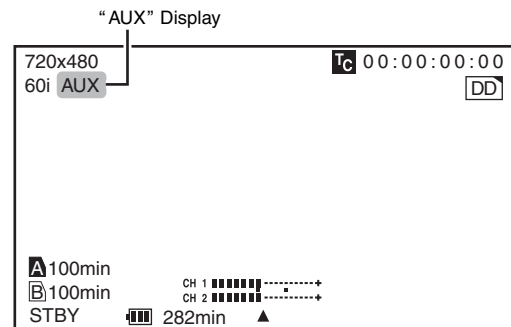

Status Screen

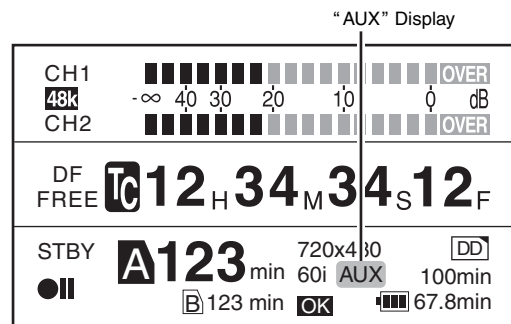

Enlarged Status Display Screen



## Input of External Synchronizing Signal (Genlock)

This camera recorder is equipped with a genlock input terminal on the side.

Synchronizing signals can also be input from a KA-M790G unit (Multicore Remote Adapter: sold separately) that is connected to the accessory connection terminal (68 pin) at the rear of the camera recorder.

The following describes the case of signal input using the side [GENLOCK INPUT] terminal.

Input the external synchronizing signal from the [GENLOCK INPUT] terminal, and synchronize the camera recorder's video and playback images with the external signal.

You can also adjust the H (Horizontal) phase of the camera recorder's video signals with respect to the external synchronizing signals on the [Genlock Adjust] screen of the [Others] menu. (Page 96)

Only horizontal (H) and vertical (V) genlock are supported. The camera recorder does not come with an SC (subcarrier) lock function.

### ■ Synchronizing Signal to Use

SD synchronizing signal : BB (Black Burst) signal  
Supports SMPTE170M(RS-170A)-NTSC  
Supports ITU-R BT.470-6 PAL

HD synchronizing signal : HDTV 3 level synchronizing signal  
Supports SMPTE296M-HD720p  
Supports SMPTE274M-HD1080i

**Note :**

- The genlock function can only be used in the Camera mode. It is not available in the AUX mode (U model only) and Media mode.

- 1 Set the camera recorder to Camera mode.
- 2 Set [Genlock Input] in the [Others] menu to "BNC". (Page 93)

**Memo :**

- During input of synchronizing signals from the accessory connection terminal (68 pin) at the rear of the camera recorder, set to "Adapter".

- 3 Set the [GENLOCK/AUX] selection switch to "GENLOCK". (U model only)

- 4 When in the standby or stop mode, input synchronizing signals from the SYNC generator to the [GENLOCK INPUT] terminal.

- When the camera recorder's video is locking to the external synchronizing signal, "SYNC LOCKING" appears on the screen.
- After locking to the external synchronizing signal is complete, the display disappears and recording can be performed.

**Note :**

- When the frame rate is set to 30p, 60p, 60i, or 24p in the [Frame & Bit Rate] item of the [Record Format] menu, 59.94 Hz synchronizing signals (vertical synchronization) are input. 50 Hz/60 Hz synchronizing signals are not synchronized.
- When the frame rate is set to 25p, 50p, or 50i in the [Frame & Bit Rate] item of the [Record Format] menu, 50 Hz synchronizing signals (vertical synchronization) are input. 59.94 Hz/60 Hz synchronizing signals are not synchronized.
- Do not connect or disconnect the input cable for the synchronizing signals during recording or playback.
- If the power is turned ON during input of external synchronizing signals, vertical oscillation may occur. This is not a malfunction.
- Signals such as VTR playback signals with jitters may not be synchronized.
- The camera recorder does not come with an SC (subcarrier) lock function. Color flash may occur during switching such as when composite signals are used by a switcher.

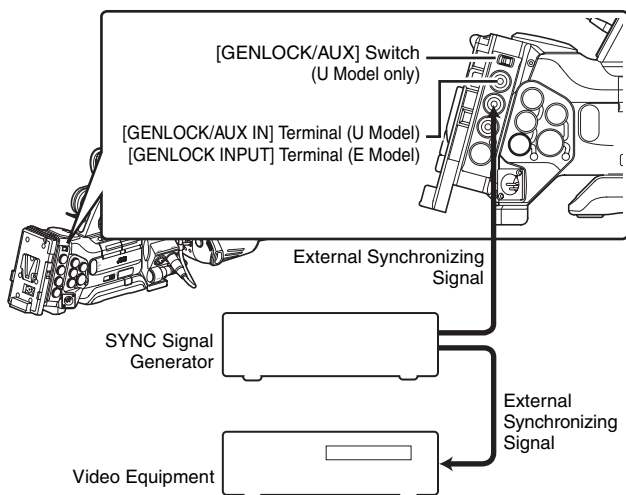

## ■ Phase Items to Synchronize

The phase items to be synchronized may vary depending on the input synchronizing signal and output video signal. (See table below)

Terminal	Output Video Signal	Input Sync Signal		
		BB	Tri-sync	
			720p	1080i
VIDEO	Composite	H, V, F	V	V, F
Y/PB/PR	SD Component	H, V, F	V	V, F
	HD Component 720p	V	H, V	V
	HD Component 1080i	V, F	V	H, V, F
HD/SD-SDI	SD-SDI	H, V, F	V	V, F
	HD-SDI 720p	V	H, V	V
	HD-SDI 1080i	V, F	V	H, V, F

H : Horizontal phase      F : Field phase  
V : Vertical phase

## Adjusting the H Phase

**1** Select [Genlock Adjust] in the [Others] menu. (☞ Page 96)

**2** Select the phase item to adjust in [Genlock Adjust].

- Analog SD H Phase : For adjusting the H phase of SD analog signal.
- Analog HD H Phase : For adjusting the H phase of HD analog signal.
- SD-SDI H Phase : For adjusting the H phase of SD-SDI signal.
- HD-SDI H Phase : For adjusting the H phase of HD-SDI signal.

**3** Select a value using the cross-shaped button (▲▼).

The H phase of the camera recorder's video signals is adjusted with respect to the external synchronizing signal input to the [GENLOCK INPUT] terminal.

You can alter the setting value for [Analog HD H Phase], [SD-SDI H Phase], and [HD-SDI H Phase] in increments of 10 by pressing down the cross-shaped button (▲▼) for 2 seconds or longer.

**Memo :** \_\_\_\_\_

- Adjustment cannot be performed when recording or playback is in progress.
- The video image may be disrupted momentarily during adjustment. This is not a malfunction.

# Displaying Return Video from External Device

Return video from an external device (switcher, etc.) can be displayed on the viewfinder or LCD monitor of the camera recorder.

You can select the destination to input return video in the [Return Input] item of the [Others] menu. (☞ Page 93)

**Note :**

- This function can only be used in the Camera mode. It is not available in the AUX mode (U model) and Media mode.

**1 Set the camera recorder to Camera mode.**

**2 Set the [GENLOCK/AUX] switch to “AUX”. (U model only)**

**3 Set the function of the [RET] button on the lens to Return Video.**

Set [Camera Function] menu → [Switch Set] menu → [LENS RET] to “Return”. (☞ Page 79)

**4 Select a destination to input the return video.**

Set the [Return Input] item in the [Others] menu. (☞ Page 93)

- Adapter : During input of return video from the KA-M790G (Multicore Remote Adapter : sold separately) connected to the accessory connector (68-pin) at the rear of the camera recorder
- Studio : During input of return video from the [STUDIO] terminal at the side of the camera recorder

**5 Select the aspect ratio for the return video.**

Set the [Return Aspect] item in the [Others] menu. (☞ Page 93)

- 16:9 : When the return video is a squeeze signal
- 4:3 : When the return video is a 4:3 aspect signal (including Letter Box)

**6 Press the [RET] button on the lens.**

The return video is displayed on the viewfinder and LCD monitor while the [RET] button is pressed down.

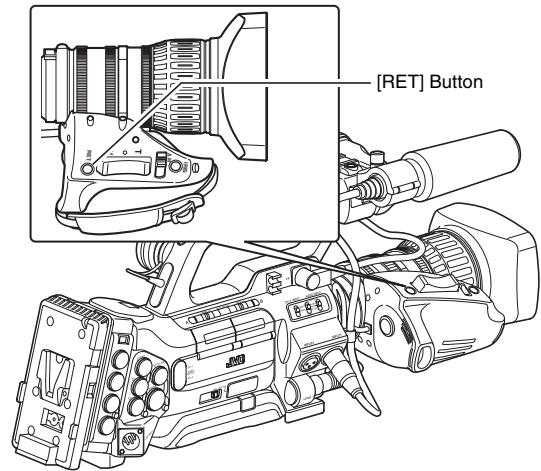

**Note :**

- The following displays and operations are invalid when return video is displayed. [Zebra], [Skin Area], [Spot Meter], [Focus Assist] ([ACCU-Focus] operation), [Aspect Marker], [Safety Zone], [Center Mark], and status displays.
- When return video is displayed, the [VF Display] and [LCD Mirror Mode] items in the [LCD/VF] menu become invalid, and the camera recorder operates as follows.
  - [VF Display] : Operates in the “Color” setting.
  - [LCD Mirror Mode] : Operates in the “Normal” setting.

# Studio System Connection

**Memo :**

- For connections between the Camera Remote Control Units, refer to the [INSTRUCTIONS] of the Camera Remote Control Unit.

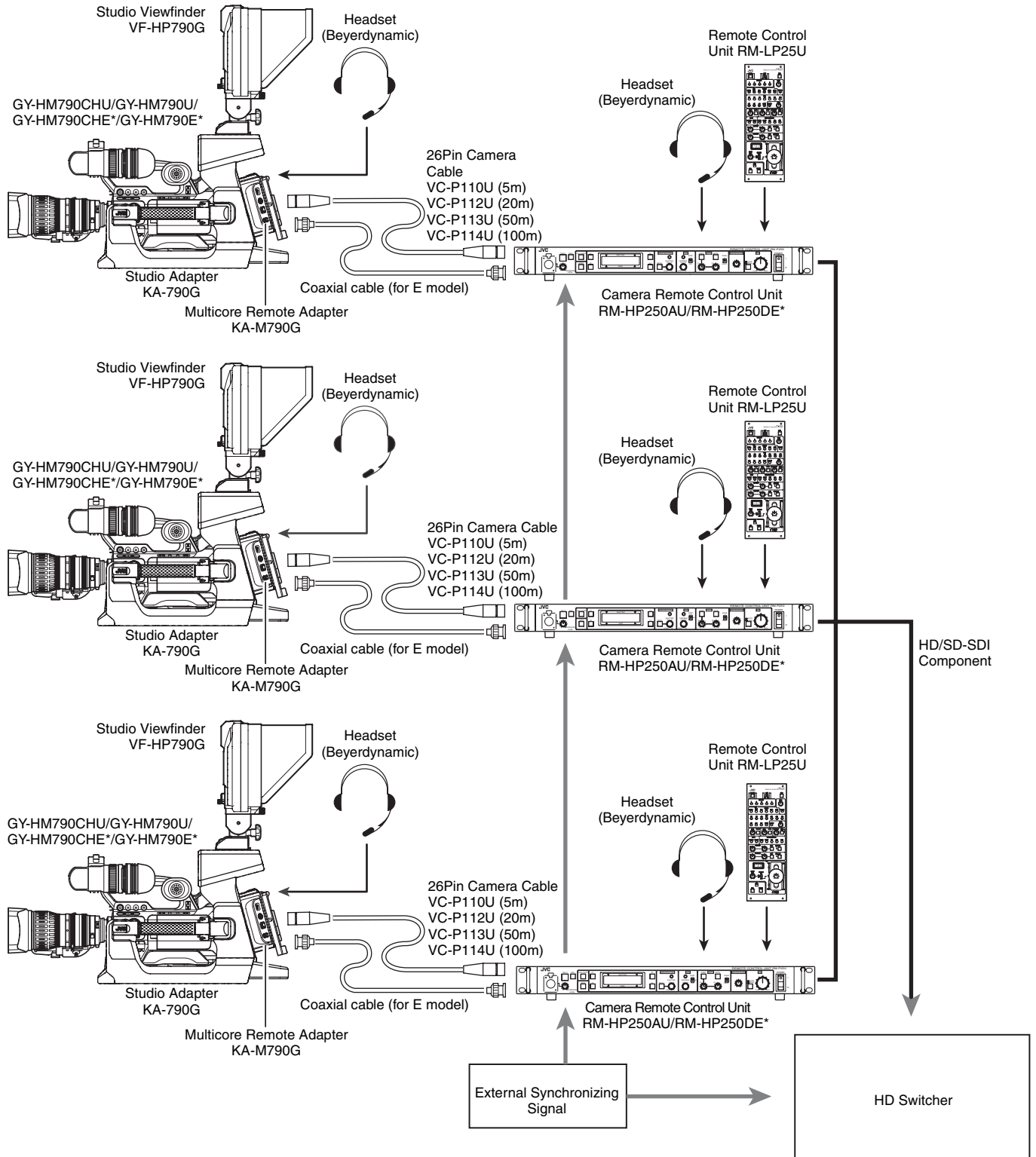

\* Models with an E suffix are for the European market and the UL Listing mark is not applicable.

## Managing/Editing Clips on a PC

### Loading Clips to the PC (USB Connection Mode)

You can load clips to a PC by connecting the camera recorder to the PC via the USB port. Doing so enables clips stored in the SDHC card to be managed and edited on the PC.

Files on the SDHC card can be managed/edited on the connected PC in this mode only for USB mass storage class devices that are recognized by the said PC as a peripheral drive.

**Memo :** \_\_\_\_\_

- Files cannot be written to the SDHC card.
- Make sure to manage/edit files recorded in the MP4 file format using the (JVC ProHD Clip Manager) PC application software in the bundled CD-ROM.
- For details on how to install the application software, refer to the [User's Guide] of the [SxS Memory Card Device Driver Software] inside the bundled CD-ROM.

### 1 Connect the camera recorder to the PC using a USB cable.

A confirmation message "Change to USB Mode" to enable the USB connection appears.

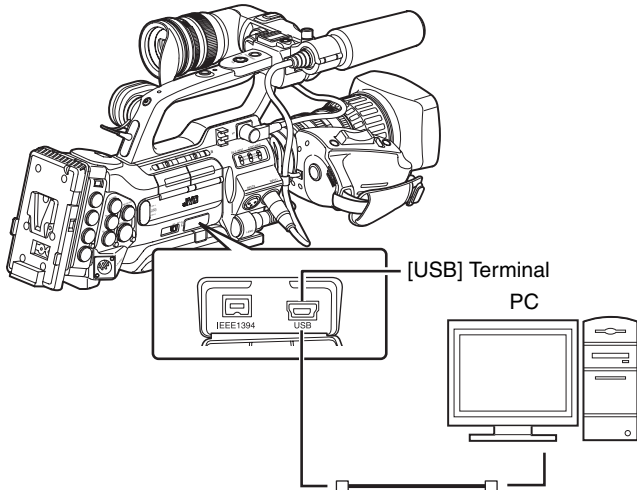

### 2 Select [Change] using the cross-shaped button (▲▼), and press the Set button (●).

The camera recorder switches to USB mode.

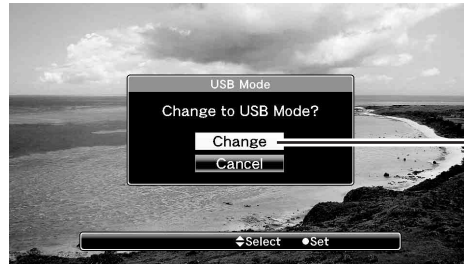

**Memo :** \_\_\_\_\_

- If recording is in progress (including recording on the camera recorder and device connected to the IEEE1394 terminal), the "Change to USB Mode" message appears after recording stops.
- If playback is in progress, the camera recorder switches to USB mode after the file closes automatically, such as when playback stops.

### ■ Disconnecting

Disable the connection on the PC, then remove the USB cable from the camera recorder.

Doing so exits the USB mode and switches the camera recorder to Camera mode.

**Memo :** \_\_\_\_\_

- The procedure for disabling the USB connection varies according to the PC in use. For details, refer to the instruction manual of the PC.

# Remote Control Unit Connection

The switch functions of the camera recorder can be configured using the remote control unit.

\* Remote control units supported : RM-LP25U, RM-LP55U, RM-LP57U

## 1 Connect the remote control unit to the camera recorder.

Connect the remote cable of the remote control unit to the [REMOTE] terminal on the terminal area of the camera recorder.

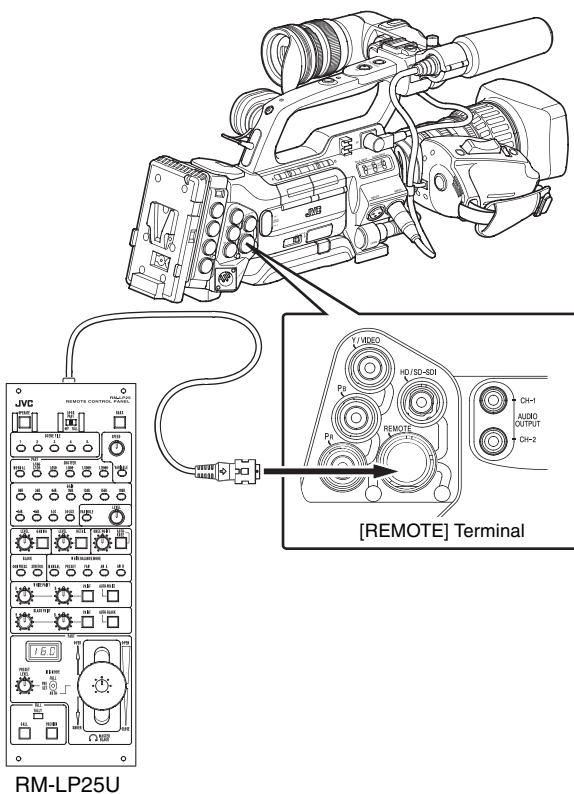

### Note :

- Turn off the power of the camera recorder when connecting a remote control unit.

## 2 Turn on the power of the camera recorder.

## 3 Set the operate switch of the remote control unit to ON.

### Memo :

- For details on functions that can be operated using the remote control unit, refer to [List of Remote Control Unit Functions] (Page 132).

## Precautions for Using the Remote Control Unit

- When the switches of the camera recorder and remote control unit are operated at the same time, the switch operation of the remote control unit takes priority over that of the camera recorder.
- Focus and zoom operations cannot be performed using the remote control unit.
- The shutter speed may vary slightly from the value displayed on the camera recorder.
- When the frame rate in [Frame & Bit Rate] of the camera recorder is set to “24p”, the shutter speed cannot be set to “1/60” using the remote control unit. Even if the shutter speed is set to “1/60”, the actual speed is “1/48”. (Page 75)
- When the camera recorder is in the Media mode, Auto White does not function even when it is operated using the remote control unit.
- When the H phase is set using a remote control unit, only the H phase of the SD signal is activated.
- When setting the H Phase using a remote control unit, any value beyond the setting range in the menu of the camera recorder cannot be set. (Page 96)

## Remote Control Unit Connection (continued)

### List of Remote Control Unit Functions

#### ■ RM-LP25U

Function		✓: Available –: Not available
SHUTTER	NORMAL	✓
	1/100* <sup>1</sup> , 1/120* <sup>2</sup>	✓
	1/250	✓
	1/500	✓
	1/1000	✓
	1/2000	✓
	VARIABLE* <sup>6</sup>	✓
	SPEED	
GAIN	-6dB	–
	-3dB	–
	0dB	✓
	3dB	✓
	6dB	✓
	9dB	✓
	12dB	✓
	15dB	✓
	18dB	✓
	ALC	✓
	LOLUX	–
	VARIABLE	–
	LEVEL	
DETAIL		✓
	LEVEL	✓
GAMMA		✓
	LEVEL	✓
BLACK	STRETCH* <sup>3</sup>	✓
	NORMAL	✓
	COMPRESS* <sup>3</sup>	✓
WHITE BALANCE MODE	MANUAL	✓
	PRESET	✓
	FAW	✓
	AW A	✓
	AW B	✓
WHITE PAINT		✓
AUTO WHITE		✓
AUTO BLACK		–
BLACK PAINT		✓

Function		✓: Available –: Not available
IRIS CONTROL		✓
	Iris F Value Display	✓
MASTER BLACK		✓
TALLY (LED)		✓
CALL* <sup>4</sup>		✓
PREVIEW		–
AUTO KNEE		✓
KNEE POINT		✓
BARS		✓
TALLY(PGM)* <sup>4</sup>	Rear Input	✓
TALLY(PVW)* <sup>4</sup>	Rear Input	✓

#### ■ RM-LP55U

Function		✓: Available –: Not available	
CAM MODE	CAM, BARS	✓	
CONTOUR	OFF, ON (LEVEL)	✓	
GAMMA	OFF, ON (LEVEL)	✓	
WHT.BAL.	MANUAL, PRESET, AUTO1, AUTO2, FAW	✓	
	AUTO WHITE	✓	
	WHITE PAINT	✓	
GAIN	dB mode    0dB, +3dB* <sup>5</sup> , +6dB, +9dB, +12dB, +15dB* <sup>5</sup> , +18dB	✓	
	ALC+EEI	✓	
	ALC	✓	
PAINT	R	✓	
	B	✓	
SHUTTER	NORMAL	✓	
	STEP	1/100* <sup>1</sup> , 1/120* <sup>2</sup> , 1/250, 1/500, 1/1000, 1/2000, 1/4000* <sup>5</sup> , 1/10000* <sup>5</sup>	✓
	EEI		✓
IRIS	MANUAL, AUTO	✓	
	AUTO IRIS LEVEL, MANUAL IRIS LEVEL	✓	
ZOOM	WIDE, STOP, TELE	–	
FOCUS	NEAR, STOP, FAR	–	
H.PHASE* <sup>5</sup>		✓	

## ■ RM-LP57U

Function		✓: Available –: Not available
MODE	BARS, CAM	✓
H.PHASE*5		✓
SC COARSE	0°, 90°, 180°, 270°	–
SC FINE		–
CONTOUR	OFF, ON	✓
	LEVEL	✓
GAIN	0dB	✓
	+6dB	✓
	+9dB	✓
	+12dB	✓
	+18dB	✓
	ALC	✓
	ALC+EEI	✓
WHITE BAL	AUTO1	✓
	AUTO2	✓
	FAW	✓
	AUTO WHITE	✓
PAINT	R	✓
	B	✓
SHUTTER	OFF	✓
	1/100*1, 1/120*2	✓
	1/250	✓
	1/500	✓
	1/1000	✓
	1/2000	✓
	EEI	✓
MASTER BLACK		✓
IRIS	MANUAL, AUTO	✓
	MANUAL LEVEL	✓
	AI LEVEL	✓

\*1 : Only when the [Frame & Bit Rate] of the camera recorder is “60”, “30”, or “24”.

\*2 : Only when the [Frame & Bit Rate] of the camera recorder is “50” or “25”.

\*3 : Switches automatically to “NORMAL” when both [STRETCH] and [COMPRESS] are set to “Off”.

\*4 : Only when [Tally System] in the [Others...] menu is set to “Studio”.

\*5 : Only available on RM-LP55U(A).

\*6 : This function may not be operable for some RM-LP25U software versions. For more details, please consult your nearest JVC dealer. Also, it cannot be controlled when the camera recorder is set to the Variable Frame Rec mode.



## Error Displays and Actions

Alarm displays on the LCD monitor and viewfinder screens, as well as the tally lamps and alarm tones are output as follows according to the alarm status.

**Memo :**

- This camera recorder makes use of a microcomputer. Noise interference from external sources may prevent it from functioning properly. When this occurs, turn off and on the power of the camera recorder again.

Error Display		Status	Action
Status Screen	Menu Screen Thumbnail Screen		
TURN POWER OFF TURN BACK ON LATER	—	System error. * The alarm sounds and the tally lamp blinks about once every second.	Turn off the power, and turn it on again. If the error persists, consult your nearest JVC dealer.
INCORRECT MEDIA [***]	Incorrect Media [***]	SDHC card is not supported (a type other than Class 6/10). (***: A, B, A/B)	Insert an SDHC card that is compliant with Class 6/10. (☞ Page 31)
INVALID MEDIA [***]	Invalid Media [***]	<ul style="list-style-type: none"> <li>• An irrecoverable error is detected.</li> <li>• SDHC card reading/writing error. (Faulty SDHC card) (***: A, B, A/B)</li> </ul>	Replace the SDHC card with a new one.
FORMATTING REQUIRED [***]	Formatting Required [***]	SDHC card is not formatted using this camera recorder. (***: A, B, A/B)	Format the card using this camera recorder. (☞ Page 33)
RESTORE MEDIA [***]	Restore Media [***]	<ul style="list-style-type: none"> <li>• SDHC card requires restoring.</li> <li>• Recording is not successfully completed. (Temporary blackout/card removed) (***: A, B, A/B)</li> </ul>	Restore the card using this camera recorder. (☞ Page 34)
NO MEDIA	—	[REC] button is pressed when an SDHC card is not inserted.	Insert an SDHC card. (☞ Page 31)
—	No Media	No SDHC card is found in Media mode or when the thumbnail screen is displayed.	Insert an SDHC card. (☞ Page 31)
—	No Clips	No clips are found on the inserted SDHC card in Media mode or when the thumbnail screen is displayed.	Insert an SDHC card that contains playable clips. (☞ Page 31, 61)
NO CLIP	—	No viewable clips are found on the card for Clip Review.	Insert an SDHC card that contains clips that can be reviewed. (☞ Page 31, 56)
REC INHIBITED	—	[REC] button is pressed when the write-protect switch of the SDHC card is set.	Turn off the write-protect switch of the SDHC card, or insert a recordable SDHC card. (☞ Page 31)
CLOSE SLOT COVER	—	<ul style="list-style-type: none"> <li>• Recording to the SDHC card is started with the cover of the selected slot left open.</li> <li>• The cover is opened while recording is in progress.</li> </ul>	Close the cover of the SDHC card slot. (☞ Page 32)
LOST MEDIA INFO [*]	Lost Media Info [*]	<ul style="list-style-type: none"> <li>• Card is removed while recording is in progress.</li> <li>• Card is removed while formatting is in progress.</li> <li>• Card is removed while restoring is in progress.</li> <li>• Card is removed while adding the OK mark.</li> <li>• Card is removed while writing a setup file.</li> <li>• Card is removed while deleting a clip. (*: A, B)</li> </ul>	Restore the card using this camera recorder. (☞ Page 34)

Error Display		Status	Action
Status Screen	Menu Screen Thumbnail Screen		
EXT-RECORDER POWER ?	—	Power of the camera recorder is turned off while the external device connection is detected, and the same connection cannot be detected several seconds after power is turned on again. (Error displays for about 7 seconds)	When making use of a connected external device, turn on the power supply on the connected device.
VIDEO FORMAT INCORRECT	—	<ul style="list-style-type: none"> <li>Video format of the file for Clip Review is different from the [Frame &amp; Bit Rate] setting of the camera recorder.</li> <li>IEEE1394 input video format is different from the [Camera Resolution] and [Frame &amp; Bit Rate] settings.</li> </ul>	Set [Camera Resolution] and [Frame & Bit Rate] correctly. (☞ Page 75)
		<ul style="list-style-type: none"> <li>The video system of the camera recorder is not compatible with the IEEE1394 input signal.</li> </ul>	Set [System Definition] in the [Record Format] menu according to the IEEE1394 signal. (☞ Page 75)
MEDIA FULL	—	<ul style="list-style-type: none"> <li>[REC] button is pressed when the media in use has no remaining space.</li> <li>Remaining space ran out during recording.</li> </ul>	Replace the SDHC card with a new one.
FAN MAINTENANCE REQUIRED	—	<ul style="list-style-type: none"> <li>Usage time of the fan has exceeded 9000 hours.</li> </ul>	<p>Check the fan and replace accordingly. For more details, consult your nearest JVC dealer.</p> <p><b>Memo :</b> _____</p> <ul style="list-style-type: none"> <li>You can check the usage time of the fan in the [Others] menu → [System Information] → [Fan Hour]. (☞ Page 95)</li> </ul>

## Tally Lamps

The tally lamps start blinking when the remaining space on the SDHC card is running out during recording, or when the battery power is running low.

Blinking Mode	Remaining Battery Power/SDHC Card Space
Blinks slowly (once every second)	<ul style="list-style-type: none"> <li>Battery power is low</li> <li>Remaining recording time on SDHC card is less than 3 minutes</li> </ul>
Blinks quickly (4 times a second)	<ul style="list-style-type: none"> <li>SDHC card is full</li> <li>Error on the camera recorder</li> </ul>

## Alarm Tone

Alarm tone is output from the monitor speaker and [PHONES] terminal when the battery level is low.

Alarm tone is output from the monitor speaker and [PHONES] terminal when the SDHC card is full. (Camera mode only)

Alarm tone is also output when an error occurs in the camera recorder.

### Memo : \_\_\_\_\_

- [Alarm Level] in the [Others] menu can be used to specify whether alarm tone is to be output, as well as the volume level. (☞ Page 93)
- Alarm tone is not output during recording.

## Troubleshooting

Symptom	Action
Power does not turn on.	<ul style="list-style-type: none"> <li>● Is the AC adapter properly connected?</li> <li>● Is the battery charged?</li> <li>● Is the power turned on immediately after it is turned off? Make sure to wait for an interval of at least 5 seconds before turning on the power again.</li> </ul>
Unable to start recording.	<ul style="list-style-type: none"> <li>● Is the record button lock switch on the handle turned on?</li> <li>● Is the write-protect switch of the SDHC card turned on? Make sure that the write-protect switch is turned off. (☞ Page 31)</li> <li>● Is the camera recorder set to the Camera mode? (Operation mode indicator: Lights up in blue/purple) If the operation mode indicator lights up in another color, camera images are not output. Use the [CAM/MEDIA] selection button to switch to the Camera mode. (☞ Page 8)</li> </ul>
Camera image is not output on the LCD monitor and viewfinder screens.	<ul style="list-style-type: none"> <li>● Is the camera recorder set to the Camera mode? (Operation mode indicator: Lights up in blue/purple) If the operation mode indicator lights up in another color, camera images are not output. Use the [CAM/MEDIA] selection button to switch to the Camera mode. (☞ Page 8)</li> </ul>
Images on the LCD monitor and viewfinder screens appear dark or blurred.	<ul style="list-style-type: none"> <li>● Readjust the brightness of the LCD monitor screen and viewfinder.</li> <li>● Is the [ND FILTER] switch set to [1/16]?</li> <li>● Is the iris closed?</li> <li>● Is the shutter speed setting too high?</li> <li>● Check the connection of the viewfinder cable.</li> <li>● Is the amount of peaking too little? Use the [LCD PEAKING +/-] button to adjust the contour for the LCD monitor screen and the [VF PEAKING] knob for the viewfinder screen. (☞ Page 28)</li> <li>● Is the [GENLOCK/AUX] selection switch set to "AUX"? Camera images are not output in the AUX mode. (U model)</li> </ul>
Playback does not start after selecting a clip thumbnail and pressing the Set button (●).	<ul style="list-style-type: none"> <li>● Is the selected clip a playable clip? Playback is not possible if the clip has a different video format setting.</li> </ul>
HDV/DV signals cannot be input.	<ul style="list-style-type: none"> <li>● Is the camera recorder set to the IEEE1394 Input mode? (Operation mode indicator: Lights up in orange)</li> <li>● Is [System Definition] in the [Record Format] menu correctly set? (☞ Page 75)</li> </ul>
No sound during playback.	<ul style="list-style-type: none"> <li>● Is the currently played clip recorded in the Variable Frame Rec mode? (☞ Page 60)</li> </ul>
The [AUDIO LEVEL CH-1/CH-2] adjustment knob does not work.	<ul style="list-style-type: none"> <li>● Is the [AUDIO LEVEL CH-1/CH-2] switch set to "AUTO"?</li> <li>● Is the [FULL AUTO] switch set to "ON"?</li> </ul>
SDHC card cannot be initialized (formatted).	<ul style="list-style-type: none"> <li>● Is the write-protect switch of the SDHC card turned on? Make sure that the write-protect switch is turned off. (☞ Page 31)</li> </ul>
Battery alarm appears even after loading a charged battery.	<ul style="list-style-type: none"> <li>● Is the battery too old?</li> </ul>
The time code and user's bit are not displayed.	<ul style="list-style-type: none"> <li>● The time code and user's bit are not displayed in IEEE1394 Input mode.</li> <li>● Even in Camera mode or SD Card mode, the time code and user's bit may not be displayed depending to the type of status display.</li> <li>● Is [TC/UB] of [Status Display] in the [LCD/VF] menu set to "Off"? To display the time code and user's bit, set it to "On". (☞ Page 91)</li> </ul>

Symptom	Action
The date and time are not displayed.	<ul style="list-style-type: none"> <li>The date and time are only displayed on the STATUS 2 and STATUS 3 screens in the Camera mode (during shooting). (☞ Page 106, 107)</li> </ul>
No output from the [Y/VIDEO], [PB], and [PR] video signal output terminals.	<ul style="list-style-type: none"> <li>Is [Output Terminal] in the [A/V Out] menu correctly set? (☞ Page 92)</li> </ul>
Incorrect display on the viewfinder.	<ul style="list-style-type: none"> <li>Is the LCD monitor used with [LCD + VF] in the [LCD/VF] menu set to "Off"? (☞ Page 88)</li> </ul>
IEEE1394 connection between the camera recorder and the external device cannot be established (e.g., no image on the camera recorder and/or external device).	<ul style="list-style-type: none"> <li>Is the operation mode correctly set? (☞ Page 8)</li> <li>Is the [INT/EXT] IEEE1394 interface terminal switch correctly set?</li> <li>Is [System Definition] in the [Record Format] menu correctly set? (☞ Page 75)</li> <li>Check the connection, such as by removing the IEEE1394 cable and inserting it again, or by reconnecting the power.</li> </ul>
When the camera recorder is in the Media mode (SD Card mode), pressing the [CAM/MEDIA] button does not switch it to the IEEE1394 Input mode.	<ul style="list-style-type: none"> <li>Is the power of the device connected to the [IEEE1394] terminal turned ON? If the power of the connected device is OFF, the camera recorder does not switch to the IEEE1394 Input mode.</li> <li>Is [System Definition] in the [Record Format] menu set to "SD (DV)"? (☞ Page 75) When the SD video system is in use, the camera recorder is unable to recognize the IEEE1394 connection in the Media mode (SD Card mode). Turn ON the power of the IEEE1394-connected device in the Camera mode, followed by switching from the Media mode (SD Card mode) to the IEEE1394 Input mode using the [CAM/MEDIA] button.</li> </ul>

## Specifications

### General

Power	: DC 12 V (10.5 V to 17 V)
Power consumption	: Approx. 26 W (During recording [when the camera recorder + standard lens + LCD monitor are in use])
Mass	
GY-HM790CHU	: Approx. 2.7 kg
GY-HM790CHE	: Approx. 2.8 kg
GY-HM790U	: Approx. 3.7 kg
GY-HM790E	: Approx. 3.9 kg
Allowable operating temperature	: 0 °C to 40 °C (32 °F to 104 °F)
Allowable operating humidity	: 30 % RH
Allowable storage temperature	: -20 °C to 60 °C (-4 °F to 122 °F)

### Camera Section

Image pickup device	: 1/3" Progressive IT CCD
Color separation prism	: F1.4, 3-color separation prism
Sync system	: Internal sync (built-in SSG)
Lens mount	: 1/3" bayonet system
Optical filter	: OFF, 1/4, 1/16
Gain	: 0dB, 3dB, 6dB, 9dB, 12dB, 15dB, 18dB, ALC
Electronic shutter	: 1/6 to 1/10000, EEI
Variable frame	: 10/30-60/30fps, 10/25-50/25fps, 10/24-60/24fps
LCD monitor	: 4.3" LCD, 800 x 480 (WVGA, 410,000 pixels)
Viewfinder	: 0.45" LCOS, 1.22 megapixels (852 x 480 x 3)

### Lens Section (GY-HM790U/GY-HM790E only)

Lens	: Canon F/1.6, 14x, f=4.4-61.6 mm (35 mm conversion: 32-448 mm)
Filter diameter	: 82 mm

### Storage Section

Supported media	: SDHC (Class 6/10)
Slots	: x 2

# Specifications (continued)

## Time Code

- Time code signal : Compliant with SMPTE/EBU
- LTC input signal : 1.0 Vp-p to 4.0 Vp-p, high impedance (unbalanced)
- LTC output signal : 1.0 Vp-p to 4.0 Vp-p, low impedance (unbalanced)

## Terminal Section

- [Y/VIDEO], [PB], and [PR] analog video output terminals
  - Analog composite output (480i or 576i : Downconverted, 4:3/16:9)
    - : 1.0 V (p-p), 75 Ω, BNC (unbalanced)
  - Component output (720p/1080i)
    - : Y: 1.0 V (p-p), 75 Ω
    - Pb, Pr: 0.7 V (p-p), 75 Ω, BNCx3 (unbalanced)
- [HD/SD-SDI] output terminal (480i or 576i : Downconverted 720p/1080i : embedded audio), BNC (unbalanced)
  - HD-SDI : Compliant with SMPTE 292 M
  - SD-SDI : Compliant with SMPTE 259 M
- [AUDIO INPUT 1/2] terminal
  - [MIC] : -60 dBu, 3 kΩ, XLR (balanced), +48 V output (phantom power supply)
  - [LINE] : +4 dBu, 10 kΩ, XLR (balanced)
- [AUDIO OUTPUT] terminal
  - : -8 ±1 dBu (during reference level input), 1 kΩ, RCA x2 (unbalanced)
- [PHONES] terminal : 3.5 mm mini jack (stereo) x 2
- [REMOTE] terminal : 6-pin JVC remote control unit connection
- [IEEE1394] terminal : 4-pin
- [USB] terminal : Mini USB-B type, USB 2.0, miniB, slave function (mass storage class) only
- [GENLOCK INPUT] terminal : BB signal
  - SMPTE 170M(RS-170A) NTSC/ITU-R BT.470-6 PAL
  - HDTV 3 level synchronizing signal
  - SMPTE 296 M/SMPTE 274 M
  - BNC
- [AUX INPUT] terminal (GY-HM790CHU/GY-HM790U only) : Composite video signal
  - 1.0 V (p-p), 75 Ω, BNC
- [STUDIO] terminal : 10 pin

## Video/Audio

- Recording time : Approx. 25 minutes (8 GB SDHC card, 35 Mbps, VBR mode)
- Video recording file format : QuickTime File Format (For Final Cut Pro)
  - MP4 File Format (HD only)
  - AVI File Format (SD only)
- : Video signal
  - HD (HQ mode) : MPEG-2 Long GOP
    - VBR, 35 Mbps (Max) MPEG-2 MP@HL
  - HD (SP mode) : MPEG-2 Long GOP
    - CBR, 25 Mbps (1440x1080i)/19 Mbps (1280x720p) MPEG-2 MP@H14
  - SD : DV
    - CBR, 25 Mbps (720x480i)/(720x576i)
- : Audio signal : LPCM 2ch, 48 kHz/16 Bit
- Video format
  - : NTSC setting
    - HD (HQ mode) : 1920x1080/59.94i, 29.97p, 23.98p, 1440x1080/59.94i (MOV only), 1280x720/59.94p, 29.97p, 23.98p
    - HD (SP mode) : 1440x1080/59.94i, 1280x720/59.94p, 29.97p, 23.98p
    - SD : 720x480/59.94i (GY-HM790CHU/GY-HM790U only)
  - : PAL setting
    - HD (HQ mode) : 1920x1080/50i, 25p, 1440x1080/50i (MOV only), 1280x720/50p, 25p
    - HD (SP mode) : 1440x1080/50i, 1280x720/50p, 25p
    - SD : 720x576/50i (GY-HM790CHE/GY-HM790E only)

## Accessories

- Viewfinder.....1
- Microphone.....1
- Lens (GY-HM790U/GY-HM790E only).....1
- Instructions.....1
- CD-ROM.....1
- Warranty Card (GY-HM790CHU/GY-HM790U only).....1

## Dimensional Outline Drawing (Unit: mm)

### ■ GY-HM790CHU/GY-HM790U

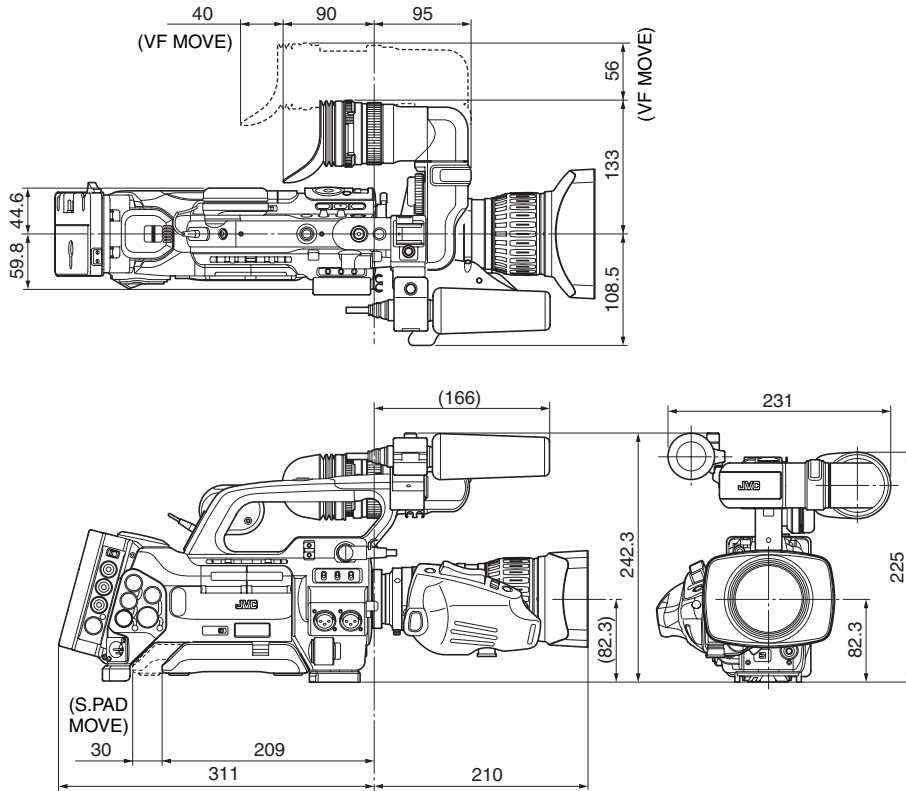

### ■ GY-HM790CHE/GY-HM790E

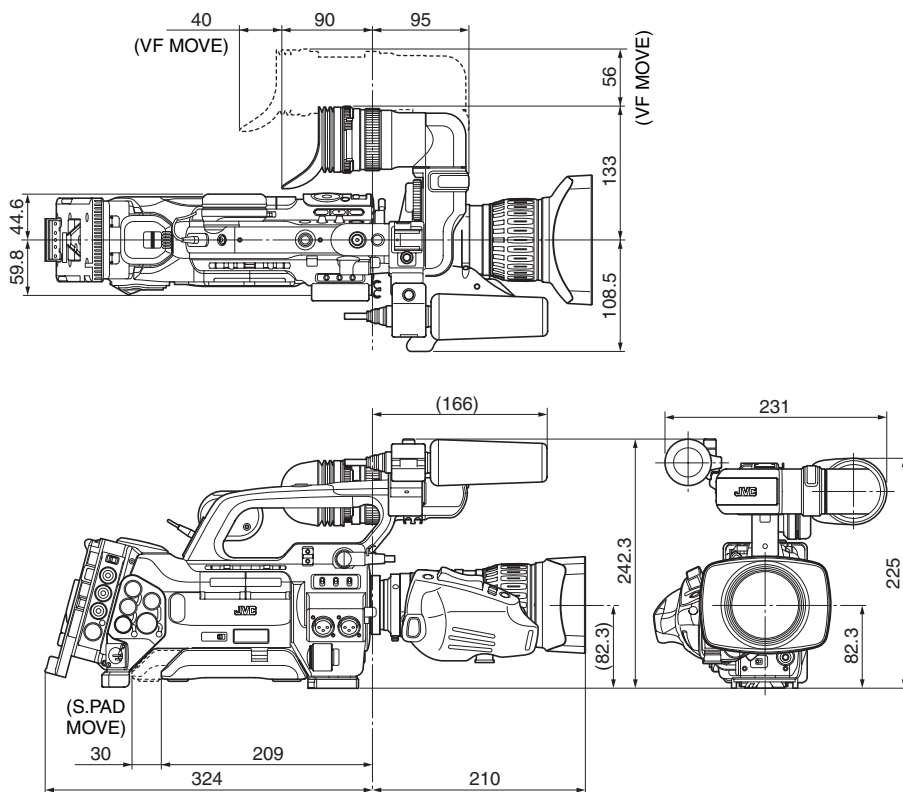

\* The specifications and appearance of this product are subject to changes for further improvement without prior notice.

GY-HM790U/GY-HM790CHU/  
GY-HM790E/GY-HM790CHE  
HD MEMORY CARD CAMERA RECORDER

---

**JVC**