

***105* KDS MODEL**

KDS-7XII Radio Control System Manual

INSTRUCTION MANUAL

使用说明书



www.kdsmodel.com

Contents

Contents.....	1
Introduction	2
Liability Declaration	2
Precaution of Safety	2
Part 1 Quick Start	3
1. Mounting of Receiver	3
2. Connect Devices to Receiver.....	4
3. Binding Transmitter and Receiver	4
4. Control Distance.....	5
Part 2 User Manual.....	5
1 Features	5
2 Transmitter Panel	6
3 Batteries Charging	7
4 Stick Adjusting	8
5 System Setting	8
6 Helicopter Mode.....	8
6.1 Reverse Setting	10
6.2 End Point Adjustment.....	11
6.3 Sub Trim Setting	11
6.4 Dual Rate Setting	11
6.5 Exponent Setting.....	12
6.6 Throttle Holding Setting.....	12
6.7 Gyro Sensitivity Adjusting	13
6.8 Aux Channel Setting.....	13
6.9 Throttle Curve Setting	14
6.10 Collective Pitch Curve Setting	15
6.11 Swash Plate Setting	15
7 Aero Mode.....	15
8 V-tail Mode.....	16
8.1 V-tail Mix control Setting	17
9 Delta Wing Mode.....	18
9.1 Delta Wing Mix Control Setting	19
10 Model Switch	19
11 Stick Trim	20
12 Throttle Warning.....	20
13 IDLE Warning	21
14 Countdown Timer for Throttle.....	21
15 No Control Protection	22
16 Using PPM Signal.....	22
17 Change Transmit Frequency.....	22

Before using this product, check that you have all of the following items. If any items are missing, please contact your dealer.

Introduction

Thank you for purchasing KDS-7XII Radio Control System (hereafter called K-7XII). This system is extremely versatile and may be used by beginners and professionals alike. In order for you to make the best use of your system and to fly safely, please read this manual carefully. If you have any difficulties while using your system, please contact your hobby dealer.

Liability Declaration

KDS model has the right to change the product, including the exterior, the functions parameter, and use request, but no notice.

KDS model does not provide any guarantee, declaration and promise for special use of any KDS products.

The recommended or text technologies data in the technology introduction for KDS model only indicates the test result at that time, but it does not mean KDS model acknowledges the result in law.

KDS model will not be responsible for the result made by using any product or circuit, including the incidental or indirect compensation.

The parameters of KDS electronic products will be changed under different conditions. The products will work only after all the functions parameters are approved by each use intension.

Precaution of Safety

- ❖ It requires professional skills and technical knowledge to install and operate R/C model properly. Incorrect installation and operation will result in severe property loss and personal injuries.
- ❖ KDS-7XII is exclusively designed for civil use of R/C models. Don't use it in any other flying machines.
- ❖ The governmence for R/C model is different in different place, therefore, please consult your local regulatory body and follow the rules and regulations to operate legally.
- ❖ Radio wave transfers almost in straight routine in 2.4GHZ, please make sure there is no any obstacle when you are operating the product. The antenna tube should point at the controlled model to ensure efficient control, and keep conductive materials away from receiver and transmitter.
- ❖ If there is prang, collision, welter and other accidents when operating, please test all the things before next operating.
- ❖ Always keep electronic components away from small children.
- ❖ Stop flying long before your batteries become low on charge. Do not rely on your radio's low

- battery warning systems, intended only as a precaution, to tell you when to recharge. Always check your transmitter and receiver batteries prior to each flight.
- ❖ Before flying, be sure that the frequency you intend to fly with is not in use, and secure any frequency control device (pin, tag, etc.) for that frequency before turning on your transmitter. It is never possible to fly two or more models on the same frequency at the same time. Even though there are different types of modulation (AM, FM, PCM), only one model may be flown on a single frequency at any one time.
 - ❖ While you are getting ready to fly, if you place your transmitter on the ground, be sure that the wind won't tip it over. If it is knocked over, the throttle stick may be accidentally moved, causing the engine to speed up. Also, damage to your transmitter may occur.
 - ❖ Before taxiing, be sure to extend the transmitter antenna to its full length. A collapsed antenna will reduce your flying range and cause loss of control. It is a good idea to avoid pointing the transmitter antenna directly at the model, since the signal is weakest in that direction.
 - ❖ Don't fly in the rain! Water or moisture may enter the transmitter through the antenna or stick openings and cause erratic operation or loss of control. If you must fly in wet weather during a contest, be sure to cover your transmitter with a plastic bag or waterproof barrier. Never fly if lightning is expected.

Part 1 Quick Start

KDS-7XII IS ADVANCED ELECTRONIC DEVICE, AND FEATURES WIDE USE. It can support multi-users and multi-equipment simultaneously, and features quick response, high precision, and strong capability for anti-jamming.

KDS-7XII supports one transmitter and several receivers, and makes it possible that single radio can control several models.

KDS-7XII supports different brand gyros.

KDS-7XII reacts quickly and precisely.

1. Mounting of Receiver

Installation position shall follow these conditions:

1. Keep the receiver away from engine, motor, ESC, battery, and other metal parts.
2. The antenna can not be covered by metal, carbon material or other electronic conduction materials.

Keep the antenna in 90 degrees with installed frame or bottom plate, which means that trying to keep the antenna visible.

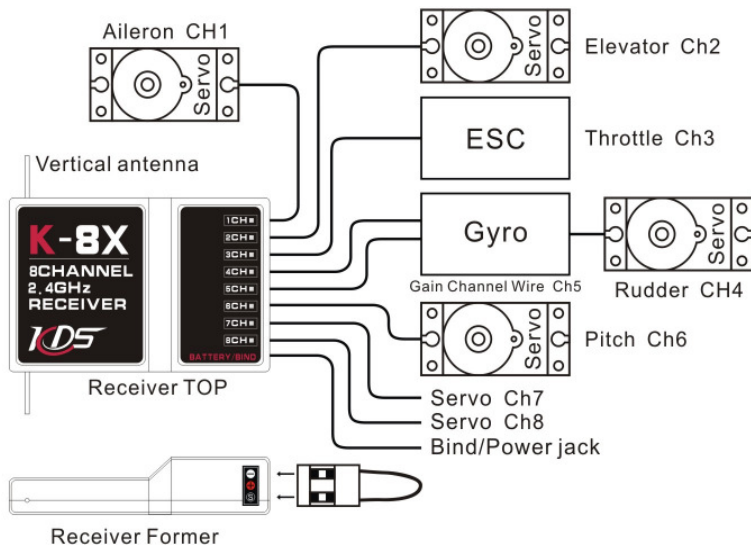

2. Connect Devices to Receiver

Connect all devices and parts to the corresponding channels. Take notice of 3P signal wire must be connected in right way. Otherwise, it will cause the severe damage to certain device or fail to work. There are some corresponding symbols of 3P on one side of the receiver:

- (-) means cathode of power connected to the earth, usually links to the black line or brown line of 3P signal wire
- (+) means the anode of power, usually links to the red wire of 3P signal wires.
- (s) means signal wire, usually links to the white or yellow wire of 3P signal wires.

Notice: please assess the power demand of the receiver of model when selecting the electricity supply style, ensure the receiver can get enough power supply when using, the voltage of the receiver not less than 4.2V at any time.

3. Binding Transmitter and Receiver

Before using K-7XII, you must bind the transmitter and the receiver. Binding them as following steps:

- 1) Plug the 'BIND line' into the 'BIND' slot of receiver. Then power on receiver by plugging the ESC line, then the LED of receiver will flash fast. Then you can remove the 'BIND line'.
- 2) Hold 'ESC' button of transmitter, then turn on it (keep holding), the LCD will display as following.



- 3) After few seconds, binding will finish, the LED of receiver will shine three times slowly, and then the transmitter enters working mode.
- 4) Release 'ESC' button of transmitter, it will enter working mode.

Notice:

- 1) KDS-7XII supports multiple receivers operation and long-distance binding, so please make sure only you bind the radio at that time. If there is any person who also uses KDS-7XII 2.4GHz remote controller system locally, please operates only after other users pare the signal.
- 2) KDS-7XII supports seven models saving in one transmitter. They are numbering as M/1 to M/7. The binding will save the serial numbers in receiver. So if you bind one receiver with M/1, it can only work when the transmitter is switched to M/1.

4. Control Distance

All radio control system equipment has an effective control range. It's not the same on the ground, water surface or flying in the sky; It is not the same on flat ground or complicated layout; It's not the same in rainy days or sunny days; And besides, the external electrical environment is changing continuously. It's quite necessary for the users who want to control at a long distance to test effective distance beforehand.

Radio wave transfers almost in a straight line, please make sure there is no object between antenna and the controlled model. And the antenna should point at receiver's antenna, and keep the controlled model in certain distance where you can see the model.

Part 2 User Manual

1 Features

1. LCD display
2. Support 7 models parameters store
3. Support 5 points throttle (THR) curve in **NORMAL** mode and **IDLE** mode.
4. Support 5 points pitch (PIT) curve in **NORMAL** mode, **IDLE** mode and **HOLD** mode.
5. Support **HELI** (helicopter) mode and **AERO** mode. Following modes are supported in each mode:

HELI mode	<ul style="list-style-type: none"> ✓ HP1: Normal helicopter with 1 servo ✓ HP2: Swash helicopter with 2 servos ✓ HP3: CCPM 120°swash helicopter with 3 servos
AERO mode	<ul style="list-style-type: none"> ✓ A/P : Normal aero plane ✓ V/P : V-tail plane ✓ D/P : Delta wing plane

Table1 - Model type list

6. 7 channels standard servo signal output
7. Support Dual rate (D/R) control
8. Support throttle hold
9. Support gyro sensitivity adjusting
10. Battery low voltage warning (voltage can be set).
11. Throttle stick position warning
12. Countdown timer for throttle
13. No signal protection

2 Transmitter Panel

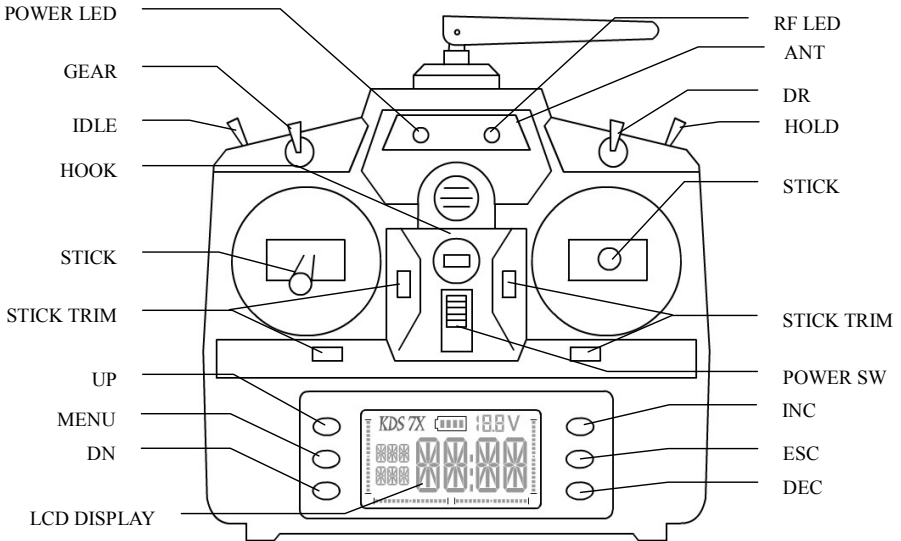

Figure 1 - Transmitter panel

Switch & Button	Description	Detail
IDLE	In HELI mode, it is used to switch NORMAL mode and IDLE mode. In AERO mode, it controls channel6.	See section-6.9 section-6.10 section-7
DR	It is used to control dual rate of aileron, elevator and rudder.	See section-6.4
HOLD	THR hold switch.	See section-6.6
GEAR	In AERO mode, it controls channel 5. In HELI mode, it controls channel 7.	See section-7 See section-6.8
UP	Page up button	
MENU	Menu button	
DN	Page down button	
INC	Increase button	
ESC	Escape button	
DEC	Decrease button	

Table2 - Button list

3 Batteries Charging

If you are using NiCd or NiH batteries, you can charge it with a external power without getting batteries out.

You can find the power slot in the right side of transmitter. Connect plug properly to charge shown as Figure2.

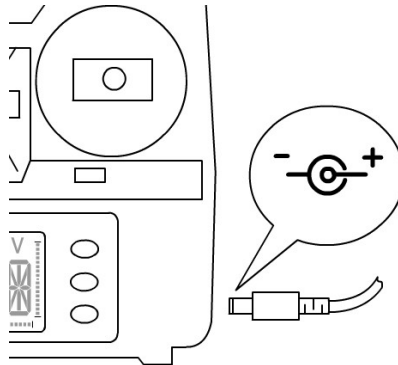

Figure2 - External Power

Warning: The power should be 11.6V, the current should be at least 50mA. Other style may be dangerous!

4 Stick Adjusting

To adjust the stick length, use 1.5mm inner hexagon screw driver to unlock the set screw. Turn the screw driver counter-clockwise to loosen the screw. Then, turn the stick clockwise to shorten or counter-clockwise to lengthen. After the control stick length have been adjusted to suit your flying style, tighten the set screw.

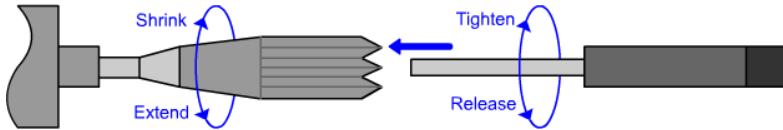

Figure3 - Stick Adjusting

5 System Setting

Hold MENU button and turn on transmitter, it will enter system setting mode, and the first item is shown like following:

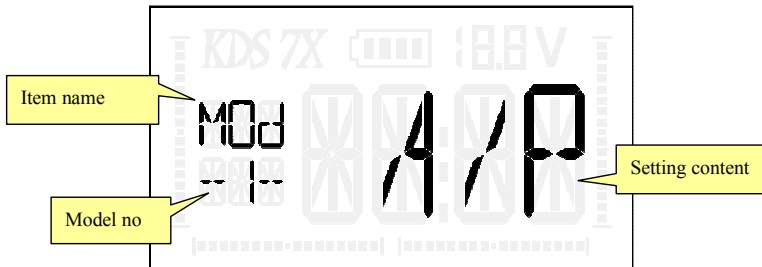

Figure4 - System setting interface

There are 6 items "MOD", "STK TYP", "BAT WAR", "BAT MIN" and "BAT MAX".

- ✓ Press MENU to change setting item as Table3
- ✓ Press UP or DN to choose model as Table3 when in MOD setting
- ✓ Press INC or DEC to change setting contents, or change "Model Type" when in MOD setting.
- ✓ Press ESC to save and exit system mode.

Item name	Description	Content
MOD	Model selection (By pressing UP/DN)	Support 7 models, see Section-10
	Model type selection (By pressing INC/DEC)	<ul style="list-style-type: none"> ✓ A/P : Normal aero plane ✓ V/P : V-tail plane ✓ D/P : Delta wing plane ✓ HL1: Normal helicopter with 1 servo ✓ HL2: Swash helicopter with 2 servos

KDS-7XII Radio Control System Manual

		✓ HL3: CCPM 120°swash helicopter with 3 servos
STK TYP	Stick mode	✓ 1 USA hand ✓ 2 JPN hand ✓ 3 Anti USA hand ✓ 4 Anti JPN hand
BAT WAR	Voltage for battery warning	
BAT MAX	Battery indicator high limit	
BAT MIN	Battery indicator low limit	
ID GEN	Regenerating ID of transmitter	See section 17

Table3 - Details of system setting

6 Helicopter Mode

HP1, HP2 and HP3 are HELI mode. In this mode, the LCD will display like following:

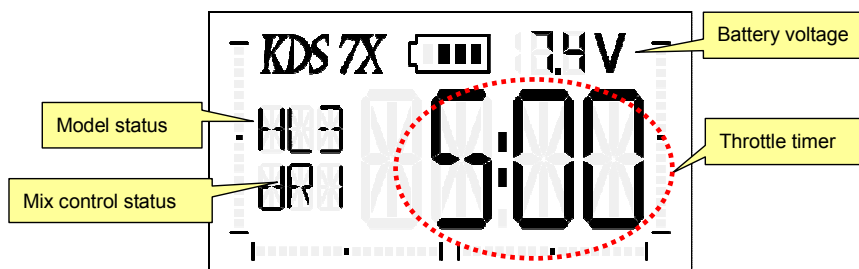

Figure5 - HELI mode

In HELI mode, the corresponding content of each channel shown in Table4.

Channel	Control	Description
1	AIL	Aileron
2	ELE	Elevator
3	THR	Throttle
4	RUD	Rudder
5	GY	Gyro
6	PIT	Pitch
7	AUX	Auxiliary

Table4 - HELI Channels list

- ✓ Press MENU will enter setting mode. In HELI mode, there are 11 items can be set, see Table5. During setting, you can press MENU to change settings, or press ESC to exit setting and return to using mode.
- ✓ Press UP or DN can switch the display "Model status" between "Model no" and "Model type"

- ✓ Press INC or DEC can modify the "Throttle Timer"

Index	Caption	Description
1	REV	Channel reverse setting
2	EPA	End point adjustment
3	TRM	Channel sub trim setting
4	D/R	Dual rate setting
5	EXP	Exponent setting
6	HLD	Throttle hold setting
7	GYO	Gyro sensitivity adjustment
8	AUX	Aux channel setting
9	THR	Throttle curve setting
10	PIT	Collective pitch curve setting
11	PLA	Swash plate setting

Table5 - HELI mode settings

In HELI mode, there are 4 flying status:

Mix control status		Description
dR1	Rate 1	Rate 1 of dual rate
dR2	Rate 2	Rate 2 of dual rate
HLD	Hold	Hold mode
IDL	Idle	Idle mode

Table6 - HELI Channels list

6.1 Reverse Setting

- ✓ Press UP or DN to change channel index from "CH1" to "CH7".
- ✓ Press INC or DEC to modify the reverse status.

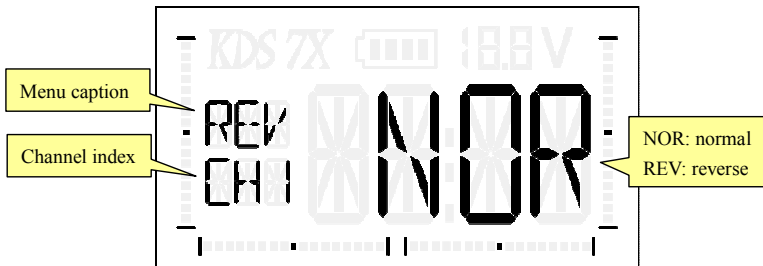

Figure6 - Reverse setting

6.2 End Point Adjustment

- ✓ Press UP or DN to change channel index from "CH1" to "CH7".
- ✓ Press INC or DEC to modify the value between "0" to "+120".

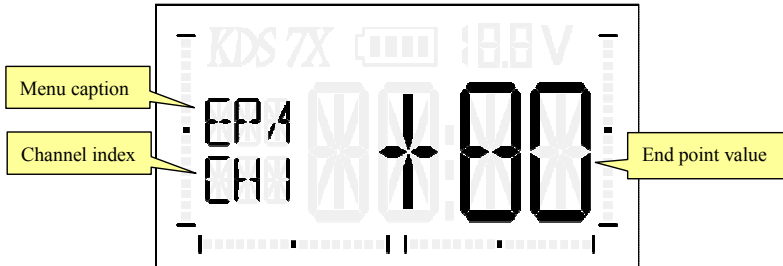

Figure7 - End point adjustment

6.3 Sub Trim Setting

- ✓ Press UP or DN to change channel index from "CH1" to "CH7".
- ✓ Press INC or DEC to modify the value between "-100" to "+100".

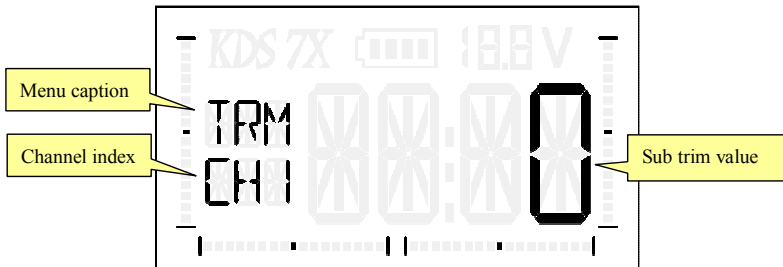

Figure8 - Sub trim setting

6.4 Dual Rate Setting

DR switch control the dual rate of aileron, elevator and rudder. And the rate of aileron, elevator and rudder can be set independency.

- ✓ Press UP or DN to change channel index between "Ail", "Ele" and "Rud" as Table6.
- ✓ Press INC or DEC to modify the value between "0" to "+120". Default value is 100 for DR SW=0, 60 for DR SW=1.

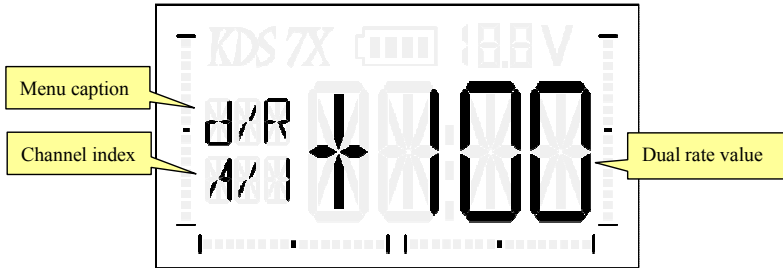

Figure9 - Dr for Ail setting.

Channel index	Description
A/1	Ail rate when DR SW=0
A/2	Ail rate when DR SW=1
E/1	Ele rate when DR SW=0
E/2	Ele rate when DR SW=1
R/1	Rud rate when DR SW=0
R/2	Rud rate when DR SW=1

Table7 - Dual rate setting

6.5 Exponent Setting

- ✓ Press UP or DN to change channel index between "Ail", "Ele" and "Rud".
- ✓ Press INC or DEC to modify the value between "-45" to "+45".

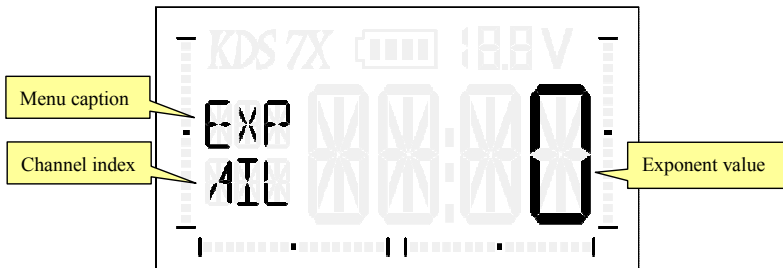

Figure10 - Exponent setting

6.6 Throttle Holding Setting

Throttle holding will lock the throttle at setting value. In lock status, the throttle signal be not changed even if the throttle stick is changed. It is controlled by HOLD switch. When HOLD switch to 1, the throttle signal is locked (holding status), when HOLD switch to 0, the throttle signal is normal (change by throttle stick).

- ✓ Press UP or DN to change channel index between "Ail", "Ele" and "Rud".
- ✓ Press INC or DEC to modify the value between "-20" to "+20", default is 0.

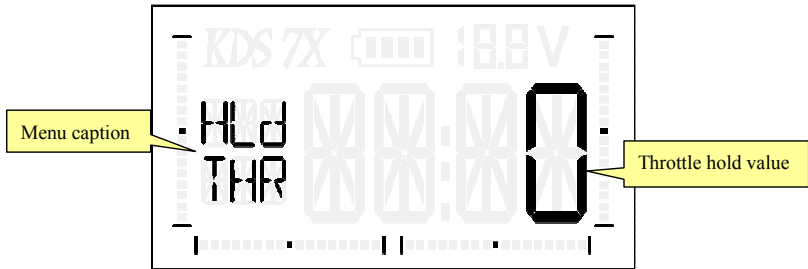

Figure11 - Throttle holding setting

6.7 Gyro Sensitivity Adjusting

There are two sensitivities for gyro. The gyro signal is one of the two values decided by IDLE switch (see Figure1). The sensitivity value can be set between -100~+100. When it is greater than 0, the gyro is in head-lock mode, when the value is less than or equal to 0, the gyro is in non-lock mode.

- ✓ Press UP or DN to change channel index between "NOR" and "IDL".
- ✓ Press INC or DEC to modify the value between "-100" to "+100", default is +100 for NOR and -100 for IDL.

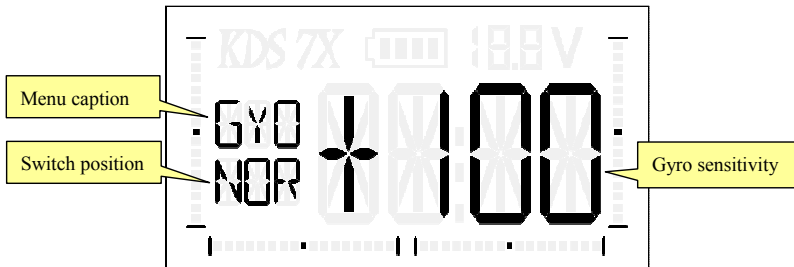

Figure12 - Gyro sensitivity setting

6.8 Aux Channel Setting

When in HELI mode, the GEAR switch controls channel 7, the AUX channel. There are two items in AUX channel setting, SW1 and SW2, control the signal of AUX channel when GEAR switch in different position.

- ✓ Press UP or DN to change channel index between "SW1" and "SW2".
- ✓ Press INC or DEC to modify the value between "-100" to "+100", default is +100 for SW1 and -100 for SW2.

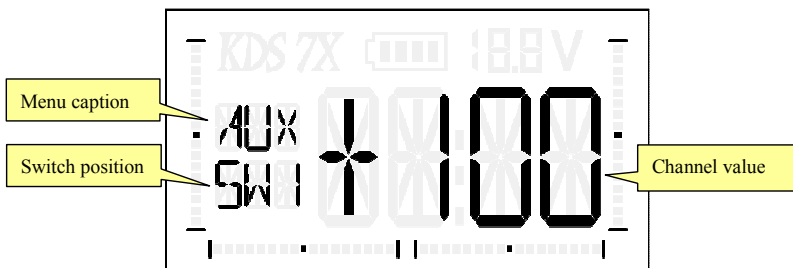

Figure13 - Aux channel setting

6.9 Throttle Curve Setting

There are two throttle curves in KDS-7XII, one is for NORMAL mode, and the other is for IDLE mode. Every curve has 5 points. Each point means the relation between signal and stick position as Table8.

- ✓ Press UP or DN to change channel index between "N/1" ~"N/5" and "I/1"~"I/5". "N?" for NORMAL mode and "I?" for IDLE mode.
- ✓ Press INC or DEC to modify the value between "0" to "+100".

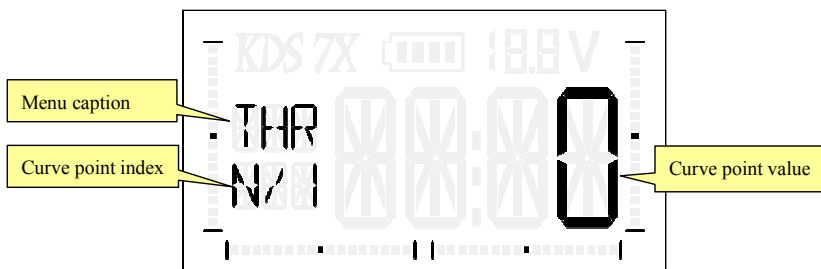

Figure14 - Throttle curve setting

Point index			Stick position	Default signal value
N/1	I/1	H/1	Stick at lowest position	0
N/2	I/2	H/2	Stick at 25% position	+25
N/3	I/3	H/3	Stick at center	+50
N/4	I/4	H/4	Stick at 75% position	+75
N/5	I/5	H/5	Stick at highest position	+100

6.10 Collective Pitch Curve Setting

There are three collective pitch curves, the first is for NORMAL mode, the second is for IDLE mode, and the third is for HOLD mode. Each point means a stick position like Table8.

- ✓ Press UP or DN to change channel index between "N/1" ~"N/5" "I/1"~"I/5" and "H/1"~"H/5". "N?" for NORMAL mode, "I?" for IDLE mode and "H?" for HOLD mode.
- ✓ Press INC or DEC to modify the value between "0" to "+100".



Figure15 - Collective pitch curve setting

6.11 Swash Plate Setting

- ✓ Press UP or DN to change channel index between "AIL" "ELE" and "PIT".
- ✓ Press INC or DEC to modify the value between "-100" to "+100". Default value is +50.

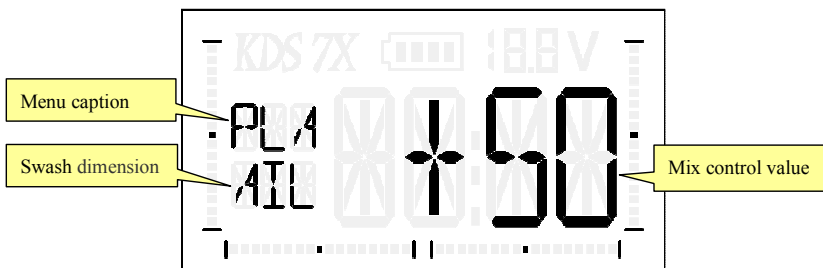

Figure16 - Swash Mix control setting

7 Aero Mode

A/P is AERO mode. In AERO mode, the LCD will display like Figure17:

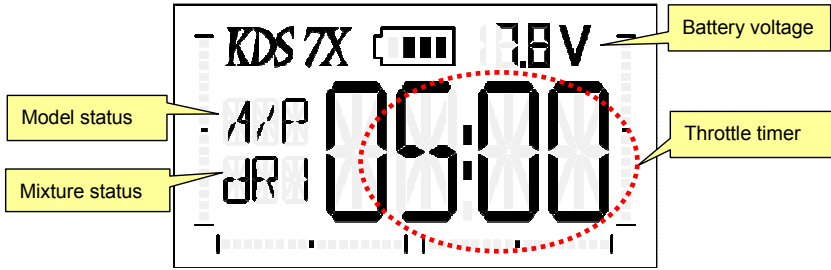

Figure17 - Aero mode

In AERO mode, the corresponding content of each channel is shown in Table9

Channel	Control	Description
1	AIL	Aileron
2	ELE	Elevator
3	THR	Throttle
4	RUD	Rudder
5	GER	Gear, control by GEAR switch
6	FLP	Flap, control by IDLE switch
7	AUX	Aux, control by D/R switch

Table9 - AERO Channels list

There are 8 settings in AERO mode, see Table10 for details. To change settings, the operations are the same as the operations in HELI mode.

Index	Caption	Description
1	REV	Channel reverse setting
2	EPA	End point adjustment
3	TRM	Channel sub trim setting
4	D/R	Dual rate setting
5	EXP	Exponent setting
6	HLD	Throttle hold setting
7	GER	Gear setting
8	FLP	Flap setting

Table10 - AERO settings

8 V-tail Mode

V/P is V-tail mode. In this mode, the LCD will display like Figure18:

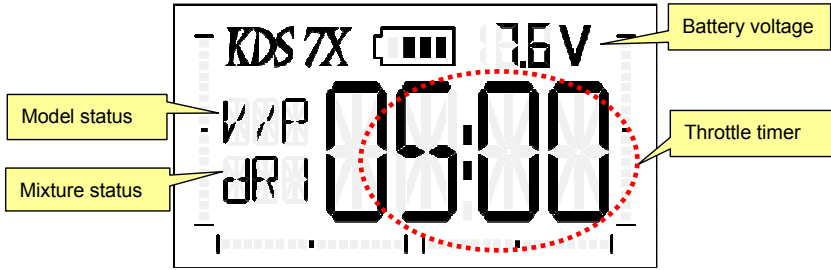

Figure18 - Aero mode

The channels and switches are the same as in AERO mode, see Table9.

There are 9 settings in V-tail mode, see Table11 for details. To change settings, the operations are the same as the operations in HELI mode.

Index	Caption	Description
1	REV	Channel reverse setting
2	EPA	End point adjustment
3	TRM	Channel sub trim setting
4	D/R	Dual rate setting
5	EXP	Exponent setting
6	HLD	Throttle hold setting
7	GER	Gear setting
8	FLP	Flap setting
9	MIX	V-tail Mix control setting

Table11 - V-tail settings

8.1 V-tail Mix control Setting

There are four items in this setting: V1, V2, V3 and V4. The value is between -100~100, default value is E>2=R>2=R>4=50, E>4=-50. The relationship between output signal and Mix control parameters is shown in Table12.

Signal	CH2	CH4
Stick		
ELE stick	E>2	E>4
RUD stick	R>2	R>4

Table12 - V-tail signal

Pressing UP or DN will change setting from V1 to V4. Pressing INC or DEC will increase or decrease the value. See Figure19.

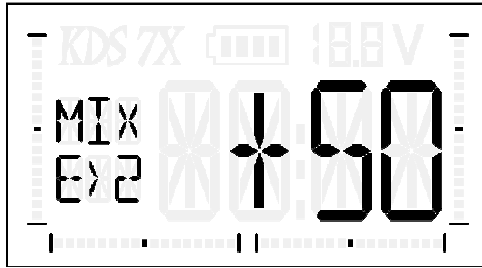

Figure19 - V-tail Mix control setting

9 Delta Wing Mode

D/P is Delta wing mode. In this mode, the LCD will display like Figure20:

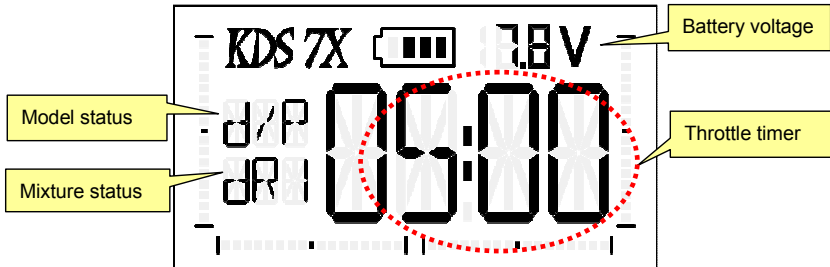

Figure20 - Delta wing mode

The channels and switches are the same as in AERO mode, see Table9.

There are 9 settings in Delta wing mode, see Table13 for details. To change settings, the operations are the same as in HELI mode.

Index	Caption	Description
1	REV	Channel reverse setting
2	EPA	End point adjustment
3	TRM	Channel sub trim setting
4	D/R	Dual rate setting
5	EXP	Exponent setting
6	HLD	Throttle hold setting
7	GER	Gear setting
8	FLP	Flap setting
9	MIX	V-tail Mix control setting

Table13 - Delta wing settings

9.1 Delta Wing Mix Control Setting

There are four items in this setting: A>1, A>2, E>1, E>2. The value is between -100~100, default value is A>1=A>2=E>2=+50, E>1=-50. The relationship between output signal and Mix control parameters is shown in Table14.

Signal Stick	CH1	CH2
ALL stick	A>1	A>2
ELE stick	E>1	E>2

Table14 - Delta wing signal Mix control

- ✓ Press UP or DN to change channel index between "A>1", "A>2" and "E>1", "E>2".
- ✓ Press INC or DEC to modify the value between "-100" to "+100".

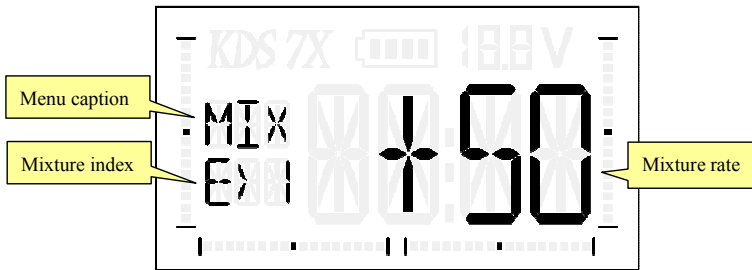

Figure21 - Delta wing Mix control setting

10 Model Switch

KDS-7XII can support 7 models; each model has its own parameters. To switch among them, you should enter system mode by holding MENU and turning on transmitter. The following screen will be shown.

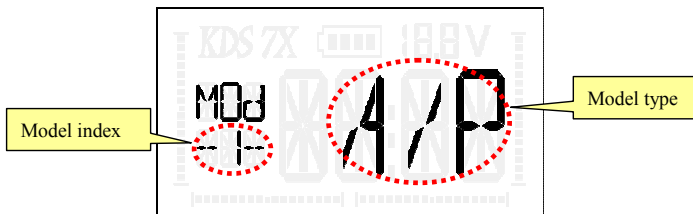

Figure22 - Model switch

Pressing UP or DN will switch from "-1-" to "-7-" which indicate each model. Press INC or DEC will change model type. When some model is selected, press ESC to return to normal using mode.

Now the transmitter will load the parameters of your selection and all your settings will be saved into the model you selected.

11 Stick Trim

When you pull buttons of stick trim (see figure 1), the screen will display as figure 23, and the meaning of stick index refer to Table 15:

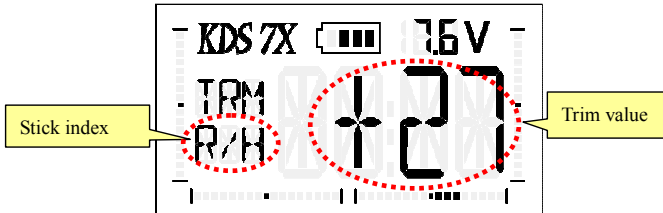

Figure23 - Stick trim

Stick index		Description
R/H	Stick of right and horizontal	
R/V	Stick of right and vertical	
L/H	Stick of left and horizontal	
L/V	Stick of left and vertical	

Table15 - Stick index

12 Throttle Warning

KDS-7XII supports throttle warning. If the stick of throttle is not in the lowest position when the

transmitter is on, it will block in warning status. You will see "THRO" in screen and hear continuously beep till you move the stick to the lowest position.



Figure24 - Throttle warning

13 IDLE Warning

KDS-7XII supports IDLE warning. If the IDLE switch on when power on, the transmitter will block in warning status. You will see "IDLE" in panel and hear continuously beep till you switch IDLE to off.

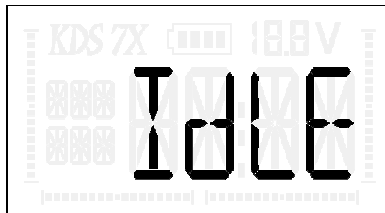

Figure25 - IDLE warning

14 Countdown Timer for Throttle

KDS-7XII has a countdown timer relate to throttle.

When in normal using status, you can see the timer on the center of screen. The default value is five minutes, like Figure23. You can press INC or DEC to change the value.

When you push throttle stick up, the timer will run from the value you set to zero. After minutes remaining, the transmitter will beep to notify you.

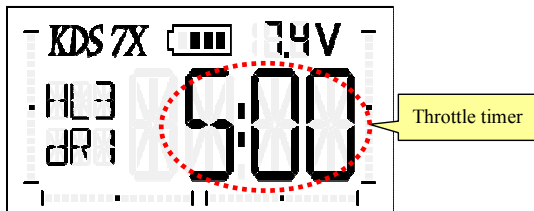

15 No Control Protection

KDS-7XII supports 'No Control Protection' function. You can predefine a set of values for each channel. The receiver will use these values if it loses signal from transmitter.

To set the values, you should do as following steps:

1. Turn on the transmitter and receiver, bind them.
2. Adjust the transmitter, and make all channels to the position as you expect.
3. Hold ESC button until the screen of transmitter will display 'NCP' like Figure 27, and the RF led shines, and the led of receiver will go out at the same time.
4. After 1 second, the transmitter and the receiver will restore to normal status, the defining of 'NCP' is done.

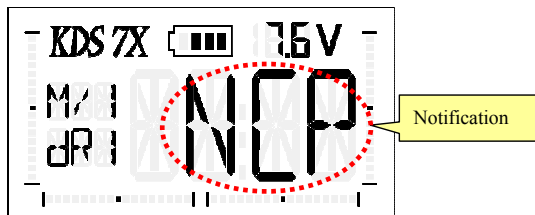

Figure27 - NCP setting

16 Using PPM Signal

There is a PPM signal output slot at bottom of KDS-7XII. When you plug the signal line into the slot, KDS-7XII will switch to PPM status automatically and you will see following screen.

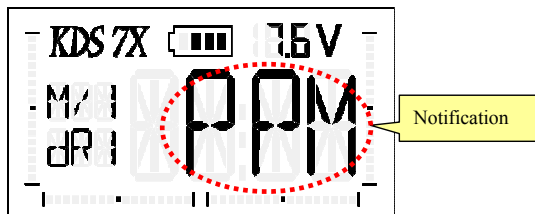

Figure 28 – PPM status

Notice: when the transmitter is in PPM status, the RF module will stop working, and then the receiver will lost signal if it was power on.

17 Change Transmit Frequency

Electric interference may exist when using remote controller system. If it interferes with the

frequency of your system, your devices will be out of control. Under these circumstances, you can try to change the transmitter frequency by following steps:

1. Enter system mode by holding MENU and turning on transmitter
2. Press MENU several times to "ID GEN" function, you can see following screen
3. Press UP or DN to change the option to 'YES'
4. Press + or - to confirm the operation
5. The transmitter will regenerate the frequency and ID, and then the display will show 'OK' and the transmitter will return to 'NO' status automatically.

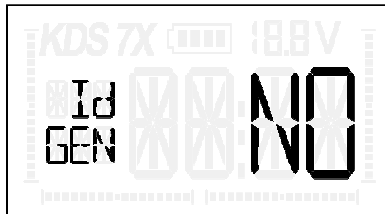

Figure 30 – ID GEN menu

Notice:

1. The new frequency is selected randomly. If the interference still exists, you can try to change it again until the interference disappears.
2. After the frequency changing, please rebind the radio.

This device complies with Part 15 of the FCC Rules.

Operation is subject to the following two conditions;

- (1) this device may not cause interference, and
- (2) this device must accept any interference received, including interference that may cause undesired operation of the device.

Any changes or modifications not expressly approved by the party responsible for compliance could void the user's authority to operate the equipment.