



Contents

- RC Vehicle (Vehicle) x 1 • RC Transmitter (Transmitter) x 1
- Antenna for RC Transmitter x 1 • Instruction Manual x 1
- 6.4V Rechargeable Battery Pack x 1 • Charger x 1 • 9V Battery x 1

Battery Precaution

- The 6.4V rechargeable battery pack must be charged before use by utilizing the battery charger which included
- Do not overcharge the battery pack. Do not charge for more than 6 hours
- Do not charge the battery pack if it shows leakage, corrosion, or has loose or exposed wires or other damage
- Do not cover the battery pack with any sort of materials while charging
- Do not touch the battery pack when it is hot. Wait until the battery pack cools before installing it in the Vehicle and before recharging
- Do not dispose of the battery in fire
- Do not dismantle the battery or charger, and do not cut the battery or charger cables
- The battery pack will be warm after charging, and hot after use in a vehicle
- The supply terminals are not to be short-circuited
- Rechargeable batteries are to be removed from the toy before being charged
- Rechargeable batteries are only to be charged under adult supervision
- Battery replacement must be only made by adults
- The transformer (charger) is not a toy
- Charge only type (500mAh Max.) rechargeable battery packs. Other types of batteries may burst causing injury to persons and damage. This power unit is intended to be correctly orientated in a vertical or floor mount position. This charger is intended to be used for charging 6.4V rechargeable battery pack with capacity 500mAh Max. It cannot be used for charging non-rechargeable batteries. Regular examination of battery charger for any damage to their cord, plug, enclosure and other parts, and that, in the event of such damage, it must not be used with the charger or battery pack charge until such damage has been repaired. Note that the 9V battery is non-rechargeable and is not to be recharged. Only batteries of the same or equivalent type as recommended are to be used. It will need replacement when transmission is poor.
- Exhausted batteries are to be removed from the product.

CAUTION-ELECTRIC TOY:

Not recommended for children under 6 years of age. As with all electric products, precautions should be observed during handling and use to prevent electric shock.

CAUTION-SUPERVISION REQUIRED-ELECTRIC TOY-

ELECTRIC TOY-UNPLUG WHEN NOT IN USE.
 INPUT: 100-240V~50/60Hz OUTPUT: 6.4V=600mA

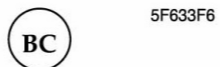

Battery Requirement

- Vehicle: 1 x 6.4V rechargeable battery pack
- Transmitter: 1 x 9V battery

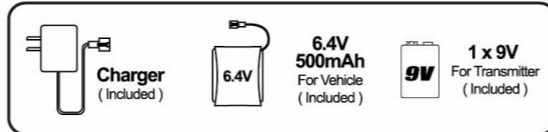

The included 6.4V rechargeable battery pack is NOT charged prior to shipment and must be charged at least 2 hours before the first use.

Charging the 6.4V Rechargeable Battery Pack for the Vehicle:

- Plug the Charger into a standard the AC socket.
- Insert the 6.4V rechargeable battery pack securely into the charger (as shown). Be sure the arrows are properly matched.
- Allow battery to charge for a minimum of 2 hours on the initial first charges. Subsequent charges require only 2 hours.
- Play time approximately 15 minutes depending on terrain and driving style.
- The Charger is intended to be correctly orientated in a vertical or floor mount position.
- When charging is completed, unplug the charger from the AC socket.
- Releases the 6.4V rechargeable battery pack from the battery charger.

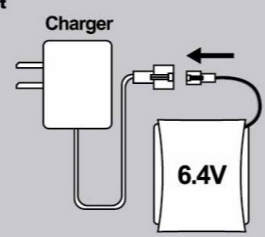

IMPORTANT: It is normal for the battery pack to become warm after charging and/or use. Be sure to allow the battery pack to cool down before using or recharging. Recharging a warm battery pack will greatly reduce the battery life.

IMPORTANT: FOR MAXIMUM PERFORMANCE, YOU MUST FULLY CHARGE BATTERY PACK BEFORE FIRST TIME USE.

ATTENTION FOR PARENTS:
The Charger & 6.4V Battery Pack need to be periodically examined for potential hazards. Any potentially hazardous parts need to be repaired or replaced.

Battery and Antenna Installation For Vehicle (Fig. 1 and Fig. 2)

- Switch the power OFF
- Unscrew the screw on the battery cover
- Open the battery cover
- Plug 6.4V battery pack into correct polarities (+/-) as shown inside the battery compartment
- Close the battery cover
- Tighten the screw on the battery cover

For Transmitter (Fig. 3 and Fig. 4)

- Switch the power OFF
- Unscrew the screw on the battery cover
- Open the battery cover
- Install 1 new 9V battery with correct polarity (+/-) as shown inside the battery compartment
- Close the battery cover
- Tighten the screw on the battery cover
- Insert the antenna into the top of Transmitter, tighten it by rotating clockwise (viewing from top of Transmitter)

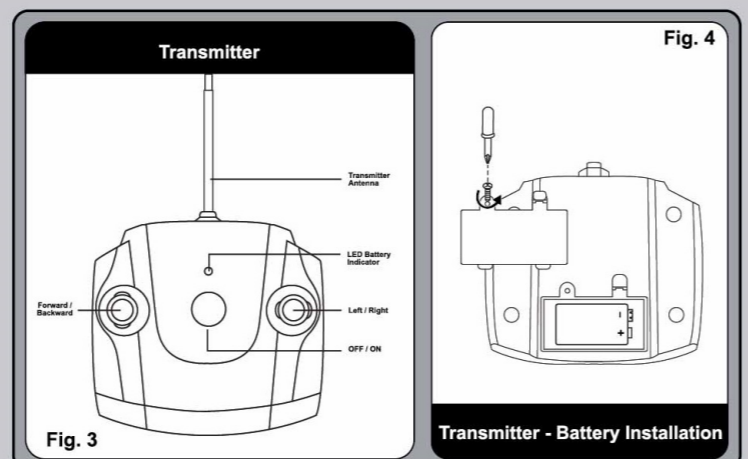
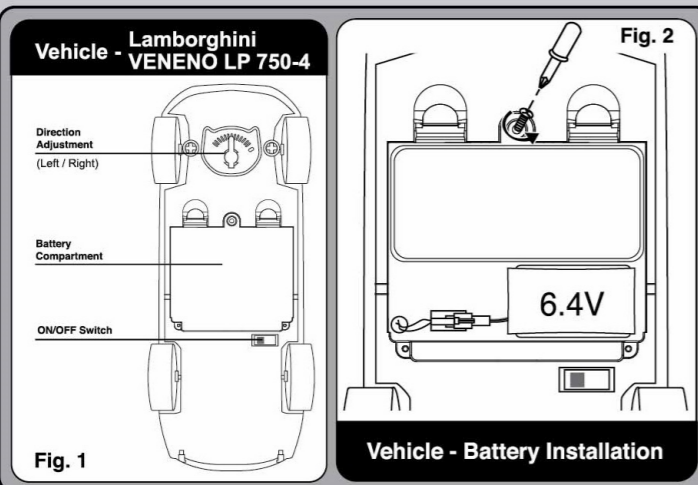
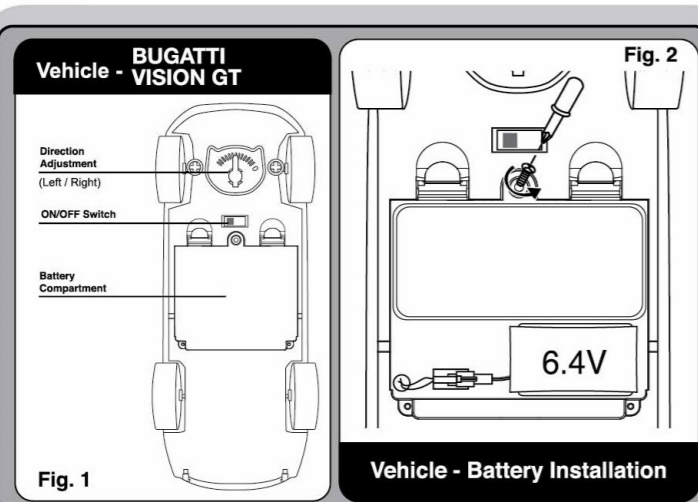

How to Play

- Switch the vehicle ON
- Use the Forward / Backward joystick (Fig.3) to drive the Vehicle forward and backward
- Use the Left / Right joystick (Fig.3) to control the Vehicle turning left or right
- If the vehicle does not run in straight line, adjust the Direction Adjustment on the vehicle chassis (Fig. 1)
- Play on smooth surface for optimum performance
- Remember to switch the power OFF for both the Vehicle, and Transmitter after using
- The optimum control range is up to 65 feet outdoors.

Performance Tips

- Do not drive on grass, dirt, sand, dust, carpet or go through water
- Do not drive in windy or rainy weather
- Avoid direct impact with obstacles
- Switch the power OFF when not in use to prevent damage due to battery leakage
- Remove all batteries from the Vehicle and Transmitter when not in use for long period
- Keep fingers, hair and loose clothing away from wheels
- The operating range can be affected by a variety of factors
 - Low Voltage of batteries in Transmitter or Vehicle
 - Interference from other items that emit radio frequency signals
- Outdoor usage is recommended in order to get optimum control range
- Play with the vehicle on a clean, smooth surface
- Clean the battery compartment to make sure it is free from dust to prevent poor battery contact

Cautions

- Do not attempt to disassemble the Vehicle or Transmitter
- Do not operate the Vehicle with same frequency with other player(s) in the same location. This can cause the vehicle to lose control
- Make sure the batteries are installed with correct polarities (+/-) as shown inside the battery compartment
- Remove the package and take out all accessories before giving the Vehicle and Transmitter to child

FCC label compliance statement:

This device complies with part 15 of the FCC rules. Operation is subject to the following two conditions:

- This device may not cause harmful interference, and
- This device must accept any interference received, including interference that may cause undesired operation. Note: This equipment has been tested and found to comply with the limits for a Class B digital device, pursuant to Part 15 of the FCC Rules. These limits are designed to provide reasonable protection against harmful interference in a residential installation. This equipment generates, uses and can radiate radio frequency energy and, if not installed and used in accordance with the instructions, may cause harmful interference to radio communications. However, there is no guarantee that interference will not occur in a particular installation. If this equipment does cause harmful interference to radio or television reception, which can be determined by turning the equipment off and on, the user is encouraged to try to correct the interference by one or more of the following measures:
 - Reorient or relocate the receiving antenna
 - Increase the separation between the equipment and receiver
 - Connect the equipment into an outlet on a circuit different from that to which the receiver is needed
 - Consult the dealer or an experienced radio/TV technician for help

Warning: Changes or modifications to this unit not expressly approved by the party responsible for compliance could void the user's authority to operate the equipment.

RSS-310 Compliance Statement:

This device complies with Industry Canada licence-exempt RSS-310. Operation is subject to the following two conditions: (1) this device may not cause interference, and (2) this device must accept any interference, including interference that may cause undesired operation of the device.

Declaration of Conformity

The product is in conformity with the requirement of EU Directive 1999/5/EC

Environmental notes:

The whole product also does not belong to household waste at the end of the product life. You can return it at collection points for the recycling of electronic and electrical instruments. The symbol on the item, instruction manual, hangtag or packing is showing this clearly. Materials should be recycled according to their respective markings. Recycling of old devices or other re-use of materials contained therein represents an important contribution to environmental protection. Please ask at your local community for the correct collection point.

Disposal of batteries

Batteries should not be disposed of in the household waste. As the consumer you are legally obliged to return batteries containing harmful substances and all other used batteries. You can hand in your old batteries at public collection points in your area or wherever batteries are sold. You will find these chemical abbreviations along with a crossed-out refuse bin on batteries containing harmful substances:
 Pb=Battery contains lead
 Cd=Battery contains cadmium
 Hg=Battery contains mercury

The packaging and instruction manual contain important information. Please keep them for future reference.
 Warning! Choking Hazard. Not suitable for children under the age of 3 years due to small parts. We reserve the right to improve/amend specifications and colors without notice.
 Warning! The Antenna of vehicle is not to be inserted into socket outlets.



The trademarks copyrights and design rights in and associated with Lamborghini, Lamborghini with Bull and Shield Device, are used under license from Automobili Lamborghini S.p.A., Italy.



MADE UNDER LICENSE FROM BUGATTI INTERNATIONAL S.A.



CONFORMS TO THE SAFETY REQUIREMENTS OF ASTM F963.

Batteries are for demonstration purposes only. They should be replaced upon purchase for optimal performance. Do not mix old and new batteries. Do not mix alkaline, standard (carbon-zinc), or rechargeable batteries.

Contents and colors may vary.

FAST LANE IS A MARK OF (EST UNE MARQUE DE/ES UNA MARCA DE) GEOFFREY, LLC, A SUBSIDIARY OF (UNE FILIALE DE/UNA SUBSIDIARIA DE) TOYS "R" US, INC.

© 2017 GEOFFREY, LLC

MADE IN CHINA (FABRIQUÉ EN CHINE/FABRICADO EN CHINA)

DISTRIBUTED IN THE UNITED STATES BY (DISTRIBUÉ AUX ÉTATS-UNIS PAR/DISTRIBUIDO EN LOS ESTADOS UNIDOS POR) TOYS "R" US, INC., WAYNE, NJ 07470

IMPORTED BY (IMPORTÉ PAR/IMPORTADO POR)

TOYS "R" US (CANADA) LTD. (LTÉE), 2777 LANGSTAFF ROAD, CONCORD, ON L4K 4M5

DISTRIBUTED IN AUSTRALIA BY (DISTRIBUÉ EN AUSTRALIE PAR/DISTRIBUIDO EN AUSTRALIA POR)

TOYS "R" US (AUSTRALIA (AUSTRALIE)) PTY LTD.(LTÉE), REGENTS PARK NSW 2143

www.toysrus.com www.toysrus.ca