



88561

RADIO CONTROL VEHICLE 1:12

Contents

- RC Vehicle (Vehicle) x 1
- RC Transmitter (Transmitter) x 1
- Instruction Manual x 1

Battery Precaution

- Alkaline batteries are recommended to be used
- Only batteries of the same or equivalent type as recommended are to be used
- Do not mix alkaline, standard or rechargeable batteries
- Do not mix old and new batteries or different type of batteries
- Non-rechargeable batteries are not to be recharged
- Rechargeable batteries are only to be charged by adult
- Rechargeable batteries are to be removed from the toy before being charged
- Batteries are to be inserted with the correct polarity
- Remove all batteries from the Vehicle and Transmitter when not in use
- Exhausted batteries are to be removed from the toy
- The supply terminals are not to be short-circuited
- Dispose of batteries properly. Do not dispose the batteries in fire – it may cause them to explode or leak causing injury or damage
- Battery installation and removal must only be done by adult
- Charger used with the toy are to be regularly examined for damage to the cord, plug, enclosure and other parts, and that, in the event of such damage, the toy must not be used with this charger until the damage has been repaired.

Battery Requirement

- Vehicle: 6 x AA battery
- Transmitter: 4 x AA battery

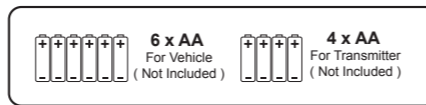

Lighting Pattern of the Vehicle under the Lights on mode

- When the Vehicle goes forward, the front lights and back lights are on.
- When the Vehicle goes backward, the front lights and back lights will be flashing.
- When the Vehicle turns left, front left indicator light and back left indicator light flash.
- When the Vehicle turns right, front right indicator light and back right indicator light flash.
- When the Vehicle brakes, the front lights and back lights will be brighter.

Performance Tips

- Do not drive on grass, dirt, sand, dusts, carpet or go through water.
- Do not drive in windy or rainy weather.
- Avoid direct impact the Vehicle with obstacles.
- Switch OFF the power when not in use to prevent damage of Vehicle and Transmitter due to leakage of electrolyte from batteries.
- Remove all batteries from the Vehicle and Transmitter when not in use for long period.
- Keep fingers, hair and loose clothing away from wheels.
- The operating range can be affected by a variety of factors.
 - Low Voltage of batteries in Transmitter or Vehicle.
 - Interference from other items that emit radio frequency signals.
- Outdoor usage is recommended in order to get optimum control range.
- Recommend to play the VEHICLE on a clean and smooth surface.
- Clean the battery compartment to make sure it is free from dust to prevent poor contact of batteries.

Cautions

- Do not attempt to disassemble the Vehicle or Transmitter.
- Do not operate the Vehicle with same frequency with other player(s) in same location that will interfere and make the Vehicle out of control.
- Make sure the batteries are installed with correct polarities (+/-) as shown inside the battery compartment.
- Remove the package and take out all accessories before giving the Vehicle and Transmitter to child to play.

FCC label compliance statement:

This device complies with part 15 of the FCC rules. Operation is subject to the following two conditions:



- This device may not cause harmful interference, and
- This device must accept any interference received, including interference that may cause undesired operation. Note: This equipment has been tested and found to comply with the limits for a Class B digital device, pursuant to Part 15 of the FCC Rules. These limits are designed to provide reasonable protection against harmful interference in a residential installation. This equipment generates, uses and can radiate radio frequency energy and, if not installed and used in accordance with the instructions, may cause harmful interference to radio communications. However, there is no guarantee that interference will not occur in a particular installation. If this equipment does cause harmful interference to radio or television reception, which can be determined by turning the equipment off and on, the user is encouraged to try to correct the interference by one or more of the following measures:

- Reorient or relocate the receiving antenna
- Increase the separation between the equipment and receiver
- Connect the equipment into an outlet on a circuit different from that to which the receiver is connected
- Consult the dealer or an experienced radio/TV technician for help

Warning: Changes or modifications to this unit not expressly approved by the party responsible for compliance could void the user's authority to operate the equipment.

RSS-310 Compliance Statement:

This device complies with Industry Canada Licence-exempt RSS-310. Operation is subject to the following two conditions: (1) this device may not cause interference, and (2) this device must accept any interference, including interference that may cause undesired operation of the device

Declaration of Conformity

The product is in conformity with the requirement of EU Directive 1999/5/EC

Environmental notes:

The whole product also does not belong to household waste at the end of the product life. You can return it at collection points for the recycling of electronic and electrical instruments. The symbol on the item, instruction manual, hangtag or packing is showing this clearly. Materials should be recycled according to their respective markings. Recycling of old devices or other re-use of materials contained therein represents an important contribution to environmental protection. Please ask at your local community for the correct collection point.

Disposal of batteries

Batteries should not be disposed of in the household waste. As the consumer you are legally obliged to return batteries containing harmful substances and all other used batteries. You can hand in your old batteries at public collection points in your area or wherever batteries are sold.

You will find these chemical abbreviations along with a crossed-out refuse bin on batteries containing harmful substances:

- Pb=Battery contains lead
- Cd=Battery contains cadmium
- Hg=Battery contains mercury

The packaging and instruction manual contain important information. Please keep them for future reference.

Warning! Choking Hazard. Not suitable for children under the age of 3 years due to small parts.

We reserve the right to improve/amend specifications and colors without notice.

Battery Installation

For Vehicle (Fig. 1 and Fig. 2)

- Switch OFF the power.
- Unscrew the screw on the battery cover.
- Open the battery cover.
- Install 6 new batteries with correct polarities (+/-) as shown inside the battery compartment.
- Close the battery cover.
- Tighten the screw on the battery cover.

For Transmitter (Fig. 3 and Fig. 4)

- Switch OFF the power.
- Unscrew the screw on the battery cover.
- Open the battery cover.
- Install 4 new AA batteries with correct polarities (+/-) as shown inside the battery compartment.
- Close the battery cover.
- Tighten the screw on the battery cover.

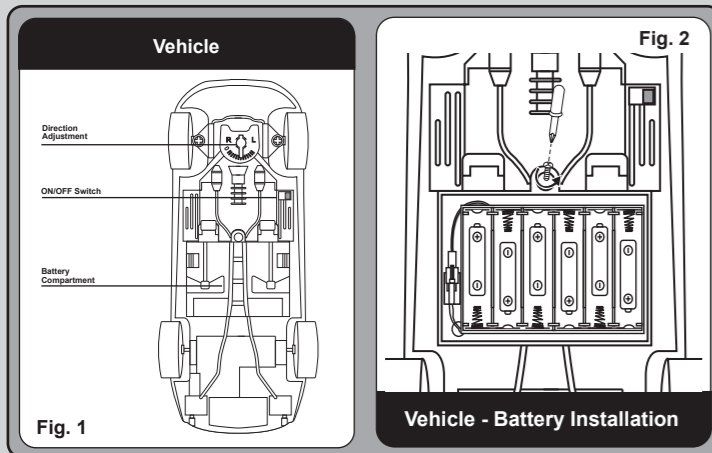
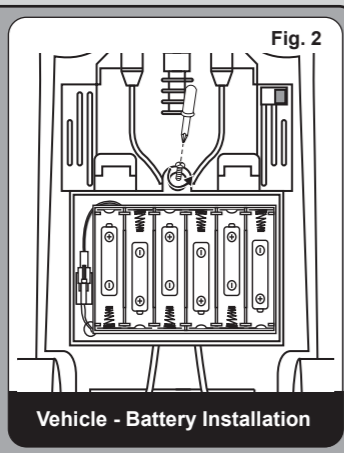

Fig. 1



Vehicle - Battery Installation

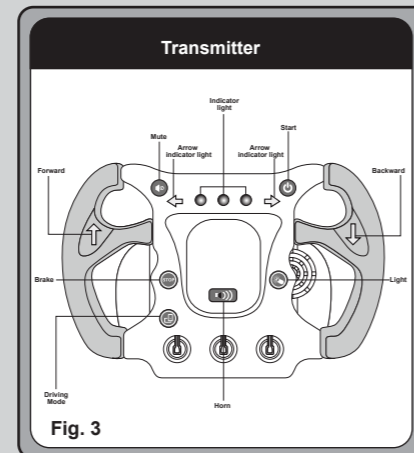
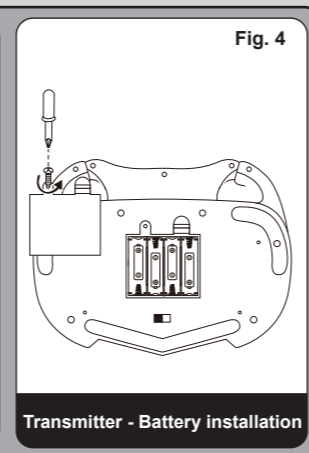

Fig. 3



Transmitter - Battery installation

How to Play

- Switch ON the Vehicle, the front and back lights of the Vehicle will be flashing.
- Switch ON the Transmitter, the indicator light (center one) of the Transmitter will be flashing.
- Touch the Start button, the indicator light (center one) of the Transmitter stop flashing, there will be engine sound and now the Transmitter is connected with the Vehicle.
- Touch the Forward button, to drive the car forward. The indicator light (left one) on the Transmitter will be lighting up, with driving sound from the Transmitter.
- Touch the Backward button, to drive the car backward. The indicator light (right one) on the Transmitter will be flashing, with backward warning sound from the Transmitter.
- Turn the Transmitter left, to drive the Vehicle to the left, the left arrow indicator light of the Transmitter will be flashing. There will be turning sound from the Transmitter.
- Turn the Transmitter right, to drive the Vehicle to the right, the right arrow indicator light of the Transmitter will be flashing. There will be turning sound from the Transmitter.
- Touch the Light button, to turn ON or OFF the lights of the Vehicle.
- Touch the Brake button, to stop the Vehicle from forward or backward, there will be a brake sound from the Transmitter.
- Touch the Mute button, to turn ON or OFF the sound of the Transmitter.
- Touch the Start button again, to disconnect the Transmitter with the Vehicle. The indicator light (center one) of the Transmitter will be flashing again. The front and back lights of the Vehicle will be flashing again.
- If the VEHICLE does not run in straight line, adjust the Direction Adjustment on the VEHICLE chassis (Fig. 1).
- Play on smooth surface to have the optimum performance.
- Remember to switch OFF the power of the Vehicle and Transmitter after playing.
- The optimum control range is up to 20m outdoor.

Driving Mode

- The default driving mode is TABLE DRIVING, where you need to put the Transmitter on the horizontal surface, and turn the Transmitter left or right to drive the Vehicle.
- Touch the Driving Mode button, the arrow indicator lights (left and right ones) will be lighting up and now it is in MOTION SENSOR driving mode, take the Transmitter with you and simply turn it left or right like real driving.
- Touch the Driving Mode button again to switch between TABLE DRIVING and MOTION SENSOR driving mode.



Made under license from Bugatti International S.A. Licensed to KidzTech Toys Manufacturing Ltd.



Ford Motor Company Trademarks and Trade Dress used under license to KidzTech Toys Manufacturing Ltd.



The trademarks copyrights and design rights in and associated with Lamborghini, Lamborghini with Bull and Shield Device, are used under license from Automobili Lamborghini S.p.A., Italy.



SHELBY® and GT500® are registered trademarks of Carroll Shelby and Carroll Shelby Licensing Inc. (Shelby).



Porsche, the Porsche shield and the distinctive design of Porsche cars are trademarks and trade dress of Porsche AG. Permission granted.



Land Rover and the Land Rover Logo are trademarks owned and licensed by Jaguar Land Rover Limited.



Official Licensed Product



KIDZTECH TOYS MANUFACTURING LTD. Room 1201,12/F, Inter-Continental Plaza, 94 Granville Road, TST East, HK. Tel: (852) 27218868 info@kidztech.net Made in China http://www.kidztech.net

