

User Manual

PORTABLE SOUND SYSTEM

Model: TY-ASC50



Read this booklet thoroughly before using and save it for future reference

 Unit must be fully charged before use

Safety information and Warnings

CAUTION

Symbol Definitions

DANGER- Indicates an imminently hazardous situation, which, if not avoided, will result in death or serious injury. This symbol appears only in the most extreme situations.

WARNING - Indicates a potentially hazardous situation which could result in death or serious injury.

CAUTION- Indicates a potentially hazardous situation, which, if not avoided, may result in minor/moderate injury or product/property/damage. It also warns against unsafe practices



The lightning flash with arrowhead symbol, within an equilateral triangle is intended to alert the user to the presence of insulated 'dangerous voltage' within the product's enclosure that may be of sufficient magnitude to constitute a risk of electric shock to persons.



WARNING: TO REDUCE THE RISK OF ELECTRIC SHOCK DO NOT REMOVE COVER (OR BACK), NO USER SERVICEABLE PARTS INSIDE REFER SERVICING TO QUALIFIED SERVICE PERSONNEL



The exclamation point within an equilateral triangle is intended to alert the user to the presence of important operating and maintenance (servicing) instructions in the literature accompanying the appliance.

READ ALL INSTRUCTIONS BEFORE USE



Always follow basic safety precautions when using this Bluetooth speaker system with Microphone, especially when children are present.

SAFETY INSTRUCTIONS

- 1) Read this Instruction Manual before you attempt to connect or operate the appliance.
- 2) Keep these instructions in good condition. Heed all warnings. Follow all instructions.
- 3) Save this Instruction Manual for future reference.
- 4) The apparatus shall not be exposed to dripping or splashing and no objects filled with liquids, such as vases, shall be placed on the product. Dry location use only.
- 5) No naked flame source, such as candles, should be placed on the product.
- 6) Children should be supervised to ensure that they do not play with the appliance.
- 7) Ventilation should not be impeded by covering the ventilation openings.
- 8) Ensure that the unit is plugged into an AC 100-240V~60/50Hz power outlet. Using higher voltage may cause the unit to malfunction or even fire catching. Turn off the unit before

- unplugging it from power source to completely switch it off.
- 9) Do not plug/ unplug the power plug into/from an electrical outlet with wet hands.
 - 10) If the power plug does not fit into your outlet, do not force the plug into an electrical socket if it does not fit.
 - 11) Use replacement parts, which are specified by the manufacturer.
 - 12) Install the unit in accordance with the manufacturer's instructions.
 - 13) Place the unit where there is good ventilation. Place the system on a flat, hard and stable surface. Do not expose to temperatures above 35°C. Allow at least 30 cm clearance from the rear and the top of the unit and 5 cm from each side.
 - 14) Press the buttons of the unit gently. Pressing them too hard can damage the unit.
 - 15) Dispose of used batteries in an environmental-responsible manner.
 - 16) Always ensure that the product is unplugged from the electrical outlet before moving or cleaning. Clean it with dry cloth only.
 - 17) Unplug the product during lightning, storms or when it will not be used for long periods of time.
 - 18) This product has no user-serviceable parts. Do not attempt to repair this product yourself. Only qualified service personnel should perform servicing. Take the product to the electronics repair shop of your choice for inspection and repair.
 - 19) NEVER let anyone, especially children, push anything into holes, slots or any other openings in the unit's casing as this could result in a fatal electric shock.
 - 20) Don't mount this product on a wall or ceiling.
 - 21) Do not place the unit near TVs, speakers and other objects that generate strong magnetic fields.
 - 22) Do not leave the unit unattended when it is in use.

NOTE: To disconnect the system completely if it not to be used for a long time, remove the AC power plug from the wall outlet.

FCC/IC Warnings

Warning: Changes or modifications to this unit not expressly approved by the party responsible for compliance could void the user's authority to operate the equipment.

NOTE: This equipment has been tested and found to comply with the limits for a Class b digital device, pursuant to Part 15 of the FCC rules. These limits are designed to provide reasonable protection against harmful interference in a residential installation. This equipment generates, uses, and can radiate radio

may cause harmful interference to radio communications. HOWEVER, there is no guarantee that interference will not occur in a particular installation. If this equipment does cause harmful interference to radio or television reception, which can be determined by turning the equipment off and on, the user is encouraged to try to correct the interference by one or more of the following measures:

- reorient or relocate the receiving antenna.
- Increase the separation between the equipment and receiver.
- Connect the equipment into an outlet on a circuit different from that to which the receiver is connected.
- Consult the dealer or an experienced radio/TV technician for help.

additional Warnings and Precautions

- **CAUTION: To PREVENT ELECTRIC SHOCK, MATCH WIDE BLADE OF PLUG TO WIDE SLOT, FULLY INSERT.**
- mains plug is used as disconnect device and it should remain readily operable during intended use. In order to disconnect the apparatus from the mains completely, the mains plug should be disconnected from the mains socket outlet completely.
- Warning: shock hazard - Do not open.
- Warning: To reduce the risk of fire or electric shock, do not expose this apparatus to rain, moisture, dripping, or splashing.
- Objects filled with liquids, such as vases, shall not be placed on the apparatus.
- **CAUTION:** use of controls or adjustments or performance of procedures other than those specified may result in hazardous radiation exposure.
- Warning: Changes or modifications to this unit not expressly approved by the party responsible for compliance could void the user's authority to operate the equipment.
- Warning: Do not place this unit directly onto furniture surfaces with any type of soft, porous, or sensitive finish. As with any rubber compound made with oils, the feet could cause marks or staining where the feet reside. We recommend using a protective barrier such as a cloth or a piece of glass between the unit and the surface to reduce the risk of damage and/or staining.
- Caution: Danger of explosion if battery is incorrectly replaced. Replace only with the same or equivalent type.
- Warning: There is a danger of explosion if you attempt to charge standard alkaline batteries in the unit. only use rechargeable NIMH batteries.

- Battery shall not be exposed to excessive heat such as sunshine, fire or the like.
- Caution marking is located at the rear or bottom of the apparatus.
- The marking information is located at the rear or bottom of the apparatus.
- Keep new and used batteries away from children. If the battery compartment does not close securely, stop using the product and keep it away from children.
- If you think batteries might have been swallowed or placed inside any part of the body, seek immediate medical attention.
- Do not mix old and new batteries.
- Completely replace all old batteries with new ones.
- Do not mix alkaline, standard (carbon-zinc), or rechargeable (ni-cad, ni-mh, etc) batteries.
- Batteries should be recycled or disposed of per state and local guidelines.
- **WARNING:** This product may contain chemicals known to the state of California to cause birth defects, or other reproductive harm (California Prop 65). Wash hands after handling.
- This product meets and complies with all Federal regulations.

Warning: Do NOT INGEST BATTERY,



Warning: To reduce the risk of electric shock, do not remove cover (or back).

NO user-serviceable parts inside. Refer RISK servicing to qualified service personnel



The exclamation point within an equilateral triangle is intended to alert the user to the presence of important operating and maintenance (servicing) instructions in the literature accompanying the appliance.



The lightning flash with arrowhead symbol, within an equilateral triangle, is intended to alert the user to the presence of uninsulated “dangerous voltage” within the product’s enclosure that may be of sufficient magnitude to constitute a risk of electric shock to persons.



This symbol indicates that this product incorporates double insulation between hazardous mains voltage and user accessible parts.

WARNING:

- Remove batteries if exhausted or if they will not be used for a long period.
- The incorrect use of batteries can cause electrolyte leakage and will corrode the compartment or cause the batteries to burst. Therefore:
- Do not mix battery types, e.g. alkaline with zinc carbonate.
- When inserting new batteries, replace all batteries at the same time.

IC Notice:

- This device complies with Canada Industry licence-exempt RSS standard(s). Operation is subject to the following two conditions:
 - (1) this device may not cause interference; and
 - (2) this device must accept any interference. Including interference that may cause undesired operation of the device.
-
- CAN ICES-3 (B)

Avis d'Industrie Canada

Le présent appareil est conforme aux CNR d'industrie Canada applicables aux appareils radio exempts de licence. L'exploitation est autorisée aux deux conditions suivantes:

- 1) l'appareil ne doit pas produire de brouillage; et

2) l'utilisateur de l'appareil doit accepter brouillage radio électrique subi même si le brouillage est susceptible d'engendrer le fonctionnement. mauvais fonctionnement de l'appareil.
Cet appareil numérique de la classe B est conforme à la norme NMB-003 du Canada.

CAN NMB-3 (B)

FCC/IC RF Exposure

Radiation Exposure Statement:

The device has been evaluated to meet general RF exposure requirement.

The device can be used in portable exposure condition without restriction.

Déclaration d'exposition aux radiations:

L'appareil a été évalué pour répondre aux exigences générales en matière d'exposition aux RF.

L'appareil peut être utilisé en condition d'exposition portable sans restriction.

Important Safety Instructions

1. Read these instructions.
2. Keep these instructions.
3. Heed all warnings.
4. Follow all instructions.
5. Do not use this apparatus near water.
6. Clean only with dry cloth.
7. Do not block any ventilation openings. Install in accordance with the manufacturer's instructions.
8. Do not install near any heat sources such as radiators, heat registers, stoves, or other apparatus (including amplifiers) that produce heat.
9. Do not defeat the safety purpose of the polarized or grounding-type plug. A polarized plug has two blades with one wider than the other. A grounding type plug has two blades and third grounding prong. The wide blade or third prong is provided for your safety. When the provided plug does not fit into your outlet, consult an electrician for replacement of the obsolete outlet.
10. Protect the power cord from being walked on or pinched, particularly at plugs, convenience receptacles, and the point where they exit from the apparatus.
11. Only use attachments/accessories specified by the manufacturer.
12.  Use only with the cart, stand, tripod, bracket, or table specified by the manufacturer, or sold with the apparatus. When a cart is used, use caution when moving the cart/apparatus combination to avoid injury tip-over.
13. Unplug this apparatus during lightning storms or when unused for long periods of time.
14. Refer all servicing to qualified service personnel. Servicing is required when the apparatus has been damaged in any way, such as power-supply cord or plug is damaged, liquid has been spilled or objects have fallen into the apparatus, the apparatus has been exposed to rain or moisture, does not operate normally, or has been dropped.
- 15) Warning to reduce the risk of fire or electric shock, do not expose this apparatus to rain or moisture. Apparatus should not be exposed to dripping or splashing, and objects filled with liquids, such as vases, should not be placed on the apparatus.
- 16) An outside antenna system should not be located in the vicinity of overhead power lines or other electric light or power circuits, or where it can fall into such power lines or circuits. When installing an outside antenna system, extreme care should be taken to keep from touching such power lines or circuits, as contact with them might be fatal.
- 17) Do not overload wall outlets and extension cords, as this can result in a risk of fire or electric shock.
- 18) Do not push objects through any openings in this unit, as they may touch dangerous voltage points or short out parts that could result in fire or electric shock. Never spill or spray any type of liquid into the unit.

Instructions de sécurité importantes

1. Lisez ces instructions.
2. Conservez ces instructions.
3. Respectez tous les avertissements.
4. Suivez toutes les instructions.
5. Ne pas utiliser cet appareil à proximité de l'eau.
6. Nettoyez uniquement avec un chiffon sec.
7. Ne jamais boucher les ouvertures de la ventilation. Installez l'unité conformément aux instructions du fabricant.
8. Ne pas installer près d'une source de chaleur telle que des radiateurs, des registres de chaleur, des poêles ou d'autres appareils (y compris des amplificateurs) qui produisent de la chaleur.
9. Ne pas contourner le dispositif de sécurité de la fiche polarisée ou de mise à la terre. Une fiche polarisée a deux lames dont une plus large que l'autre. Une fiche de terre a deux lames et une broche de terre. La lame large ou la troisième broche sont fournies pour votre sécurité. Lorsque la fiche fournie ne s'insère pas dans votre prise, consultez un électricien pour remplacer la prise obsolète.
10. Évitez que le cordon d'alimentation ne soit piétiné ou pincé, en particulier sur les prises, les multiprises et au niveau de la sortie de l'appareil.
11. N'utilisez que des fixations/accessoires indiqués par le fabricant.
12.  Utilisez uniquement avec le chariot, le stand, le trépied, le support ou la table recommandée par le fabricant, ou vendu avec l'appareil. Lorsqu'un chariot est utilisé, faites attention lors du déplacement de la combinaison du chariot/appareil pour éviter de vous blesser en cas de chute.
13. Débranchez cet appareil pendant les orages ou lorsqu'il n'est pas utilisé pendant une longue période.
14. Confiez toute réparation à du personnel qualifié. Une réparation est nécessaire lorsque l'appareil a été endommagé de quelque façon que ce soit, par exemple, si le cordon d'alimentation ou la fiche sont endommagés, du liquide a été renversé ou des objets sont tombés dans l'appareil, l'appareil a été exposé à la pluie ou à l'humidité, s'il ne fonctionne pas normalement, ou s'il est tombé.
15. Avertissement pour réduire le risque d'incendie ou de décharge électrique : ne pas exposer cet appareil à la pluie ou à l'humidité. L'appareil doit être gardé à l'abri des gouttes ou des éclaboussures d'eau ; ne posez jamais un objet contenant de l'eau sur cet appareil, par exemple un vase.
16. Le système d'antenne extérieure ne devrait pas être situé à proximité de lignes électriques aériennes ou d'autres circuits d'éclairage ou d'alimentation électrique, ou à un endroit où il peut tomber sur ces lignes ou circuits électriques. Lors de l'installation d'un système d'antenne extérieure, prenez extrêmement soin de ne pas toucher ces lignes ou circuits électriques, car tout contact peut être fatal.
17. Ne pas surcharger les prises murales et les câbles de rallonge, car cela peut entraîner des risques d'incendie ou d'électrocution.
18. Ne pas introduire d'objets par les ouvertures de cet appareil, car ils pourraient entrer en contact avec des points de tension dangereux ou court-circuiter des pièces qui pourraient provoquer des incendies ou une décharge électrique. Ne jamais verser ou pulvériser de liquide quel qu'il soit sur l'unité.

Guide to the Appliance

Top View

1. 3.5mmAUX IN JACK
2. 6.3mm MIC JACK1
3. 6.3mm MIC JACK2
4. USB PORT
5. ECHO BUTTON
6. POWER ON/OFF BUTTON
7. LIGHT BUTTON
8. LCD DISPLAY
9. FUNCTION BUTTON
10. 10/M./FOLD.+ BUTTON
11. VOLUME CONTROL
12. HANDLE
13. ►► /TUN.+ BUTTON
14. ►| /PAIR/AUTO BUTTON
15. ◀◀ /TUN.- BUTTON
16. MIC VOL. CONTROL
17. 10/M./FOLD.- BUTTON
18. P-MODE/M. BUTTON
19. CHARGE INDICATOR
20. PAIR INDICATOR
21. BASS BUTTON
22. EQ BUTTON
23. USB CHARGE PORT

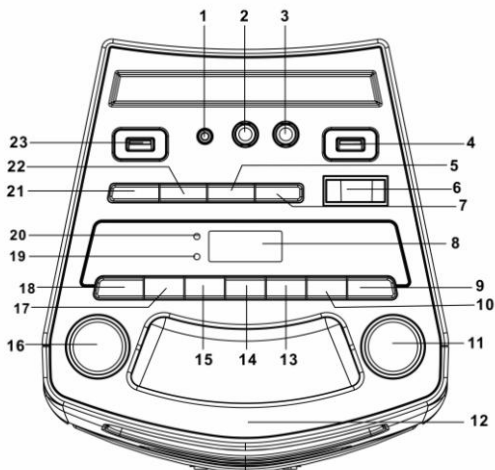

Front and Back view

24. SPEAKERS
25. LED DISCO LIGHT
26. SPEAKER GRILL
27. AC SOCKET
28. VENTILATION HOLES
29. FM ANTENNA
30. TWEETER

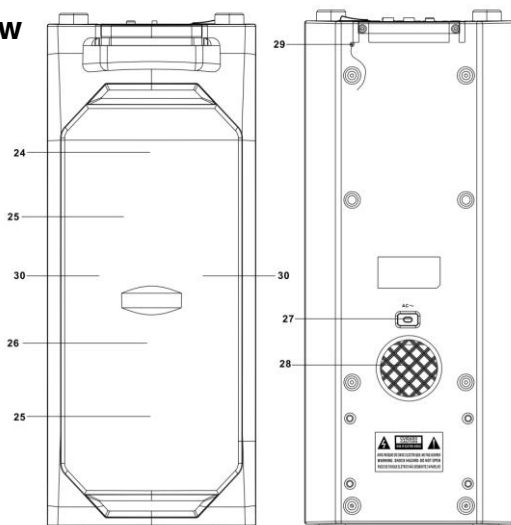

Getting Started

POWER SOURCE

This unit works with rechargeable lead-acid battery (the battery capacity 4000mAh). Fully charge the unit (around 7 hours) before using the product for the first time. The playback time has about 2hours after full charging. Unplug the AC Power cord from the AC socket to work on the battery pack after fully charged. Plugging the AC Power cord while the battery pack is attached initiates the charging of this battery, the charge LED indicator lights red during charging, when the battery is fully charged the indicator will turn to green. When the unit is with low battery, the LED indicator will flash in red.

Warning: Do not change the battery, only high-qualified personnel can perform this operation.

OPERATION INSTRUCTION

BASIC FUNCTION

TURNING THE UNIT ON/OFF

Press the power ON/OFF button to switch the unit on/off.

Electrostatic Discharge hints – The unit may reset or may not reset to normal operation mode due to electrostatic discharge, just switch it off and reconnect again.

SETTING THE FUNCTION MODE

To change the function modes, press the **FUNCTION** button repeatedly to choose USB/Bluetooth/AUX/Radio function.

ADJUSTING THE VOLUME

1. Rotate the **VOLUME** knob on the unit to increase or decrease the music volume.
2. Rotate the **MIC VOL.** knob on the unit to increase or decrease the microphone volume.

BASS ADJUSTMENT

Press the **BASS** button on unit to increase the bass effect.

EQUALIZER (EQ) FUNCTION

This unit has a built-in equalizer system, Press the **EQ** button on unit to select a setting that best matches the music style: FLAT, CLASSIC, ROCK, POP and JAZZ.

USB CHARGING

This unit provides a 5V 1A USB charging port for charging your smart phone. Connect the USB cable of your smart phone to the USB CHARGE port for charging.

MICROPHONE ECHO ADJUSTMENT

Press the **ECHO** button on unit turn on or off the microphone echo effect.

FLASHING LIGHT

There are 5 modes for the DISCO LED lighting. Press the **LIGHT** button to choose the light modes. To inactivate the light, press the **LIGHT** button until "OFF" showed on the display.

- L-1: Blue LED will be on constantly when it is selected.
- L-2: Blue LED will be on flashing mode.
- L-3: Red LED will be on constantly.
- L-4: Red LED will be on flashing mode.
- L-5: 7 colors LED will be on flashing mode.

RADIO OPERATION

Listen to FM radio broadcasts. Press the **FUNCTION** button on the unit, the display reads FM and the radio frequency.

Note: in order to get the best reception, extend the FM ANT. on the rear of the unit before use to its full length.

TUNING TO A RADIO STATION

If you know the station frequency that you want to tune to directly:

Tune to a station by press the ►►/TUN.+ or ◀◀/TUN.- button repeatedly. The station frequency is shown on the display.

AUTOMATIC TUNING STOP

Press and hold the ◀◀/TUN.-BUTTON or ►► /TUN.+ BUTTON to start tuning, Tuning stop automatically when a station is received.

AUTO PRESET MEMORY / SCAN

To scan for stations within reception range and save them to preset memory automatically, press and hold the ►◄/PAIR/AUTO button. After the unit is finished scanning, the unit will automatically tune to preset number 1 (P01). To tune to a preset station:

- To tune to the next preset station, press the **10/M./FOLD.+** button.
- To tune to the previous preset, press the **10/M./FOLD.-** button.

MANUAL PRESET MEMORY OPERATION

Choose which stations to save in preset memory instead of scanning automatically.

1. Use the ►►/TUN.+ or ◀◀/TUN.- button to tune to the station that you want to save as a preset (e.g., 93.1).
2. Press the **P-MODE/M.** button. "P 0 1" will flash on the display to indicate that you are saving the station as Preset Memory 01. (To change the preset memory number, press the **10/M./FOLD.+** or **10/M./FOLD.-** buttons.)
3. Press the **P-MODE/M.** button to finish saving the station (e.g., P01 is now set to 93.1).
4. To save another station, repeat steps 1 to 3. You may save up to 30 FM stations.

USB OPERATION

This unit provides two USB ports for music playback.

1. Press the **FUNCTION** button on unit to select "USB" mode.

2. Plug the USB memory stick to the USB port on top of the unit(The unit can support up to 32G USB device). Playback will start automatically from Track 1.
3. To pause playback, press the **▶||** /PAIR/AUTO button on unit. The playing time will flash on the display.
4. To resume playback, press the **▶||** /PAIR/AUTO button again.
5. To select a desired track, press the **▶▶** or **◀◀** button respectively during playing until the desired track appears on the display. The unit will start play automatically.
6. To search for a particular passage during playback, press and hold the **▶▶** or **◀◀** button to scan the current playing track at high speed until desired point (passage) appears, then release the button for normal playback mode.
7. To select a song which track number exceeds 10,press the **10/M./FOLD.+** or **10/M./FOLD.-** button each time to skip forward/backward 10 tracks, then press the **▶▶** or **◀◀** button to select desired track.
8. To select a desired folder (if the USB contains more than one folder), press and hold the **10/M./FOLD.+** or **10/M./FOLD.-** button each time to skip forward/backward a folder, then press the **▶▶** or **◀◀** button to select desired track.

Important: The USB port is intended for data transfer only, other devices cannot be used with this USB connection. The use of USB extension cords is not recommended. Don't plug the USB from the unit when playing or reading the USB device.

REPEAT PLAY

You can play one track or all tracks on the USB repeatedly.

To Repeat a Single Track

- 1.Press **P-MODE/M.** button on unit during play, the display will show “**↶**” and the current track will be played over and over again.
- 2.To cancel repeat play, press **P-MODE/M.** button on unit until “**↶**” disappears from the display.

To repeat all the Tracks

- 1.Press **P-MODE/M.** button on unit until the “**↷**” shows steadily on the display, all tracks on the USB will be played over and over again.
- 2.To cancel repeat play, press the **P-MODE/M.** button on unit until “**↷**” disappears from the display.

To repeat the folder (only for USB which contains more than one folder)

1. Press the **P-MODE/M.** button on unit until “**↷ FOLDER**” shows steadily on the display, the current folder will be repeated over and over again.
2. To cancel repeat play, press the **P-MODE/M.** button on unit until “**↷ FOLDER**” disappears from the display.

RANDOM PLAY

Press the **P-MODE/M.** button on unit in play mode till the “**RAND**” shows steadily on the display, the random play will start from next track automatically. Press the **P-MODE/M.** button on unit again until the “**RAND**” disappears from the display to cancel.

BLUETOOTH OPERATION

1. Press the **FUNCTION** button on unit to switch to BLUETOOTH function, the LCD will display “**BT**” and the pair indicator will flash at high speed.
2. Turn on the Bluetooth function on the device, scan the unit “**KP626T**” and connect, then input the password 0000 if required, the pair indicator keep light up to indicate connection done, and the display will show “**BT**” steadily. Press Play to start playback.
3. Rotate the **VOLUME** knob on the unit or adjust the volume on the external device to increase or decrease the music volume to your desired level.
4. Press and hold the **▶|| /PAIR/AUTO** button to disconnect Bluetooth.

Note: The Bluetooth works best within 10 meters in open air.

AUX-IN OPERATION

1. Press the **FUNCTION** button on unit to select the “AUX” mode.
2. Connect your audio device to the AUX IN jack on the top panel of the unit with an AUX IN cable.(audio cable is not included)
3. Rotate the **VOLUME** knob on the unit or adjust the volume on the external device to increase or decrease the music volume to your desired level.
4. Control the playback with your audio device.

MIC JACK OPERATION

Microphone input is available in all modes.

1. Connect your microphone to the 6.3mm **MIC JACK** found on the top panel of the unit.
2. Rotate the **MIC VOL.** knob on the unit to increase or decrease the microphone volume.
3. Press the **ECHO** Button to turn on or off the echo effect of the microphone.

Technical Specifications

GENERAL

Power Requirements	AC100-240V~60/50Hz
Battery type	Built-in rechargeable battery, 4000mAh/12V, lead-acid
Power consumption	40W
Power output	25W X 2
FM frequency	FM 87.5-108 MHz
AUX in jack	3.5mm
Microphone jack	6.3mm
Work temperature	5° C - +35° C

USB memory section

Playback format	WMA/MP3
Memory	32MB to 32GB

Bluetooth

Communication system	Bluetooth Standard version 2.1+EDR
Reception Range	10 meter (line-of-sight distance)
Compatible Bluetooth profiles	Advanced Audio Distribution Profile (A2DP)

ACCESSORIES

Instruction Manual x 1pc
AC Cord x 1pc
Microphone x 1pc

Note: Specifications are subject to change for continuous improvement without prior notice.