

**FS-1100**  
**FS-1300D**

## **Operation Guide**

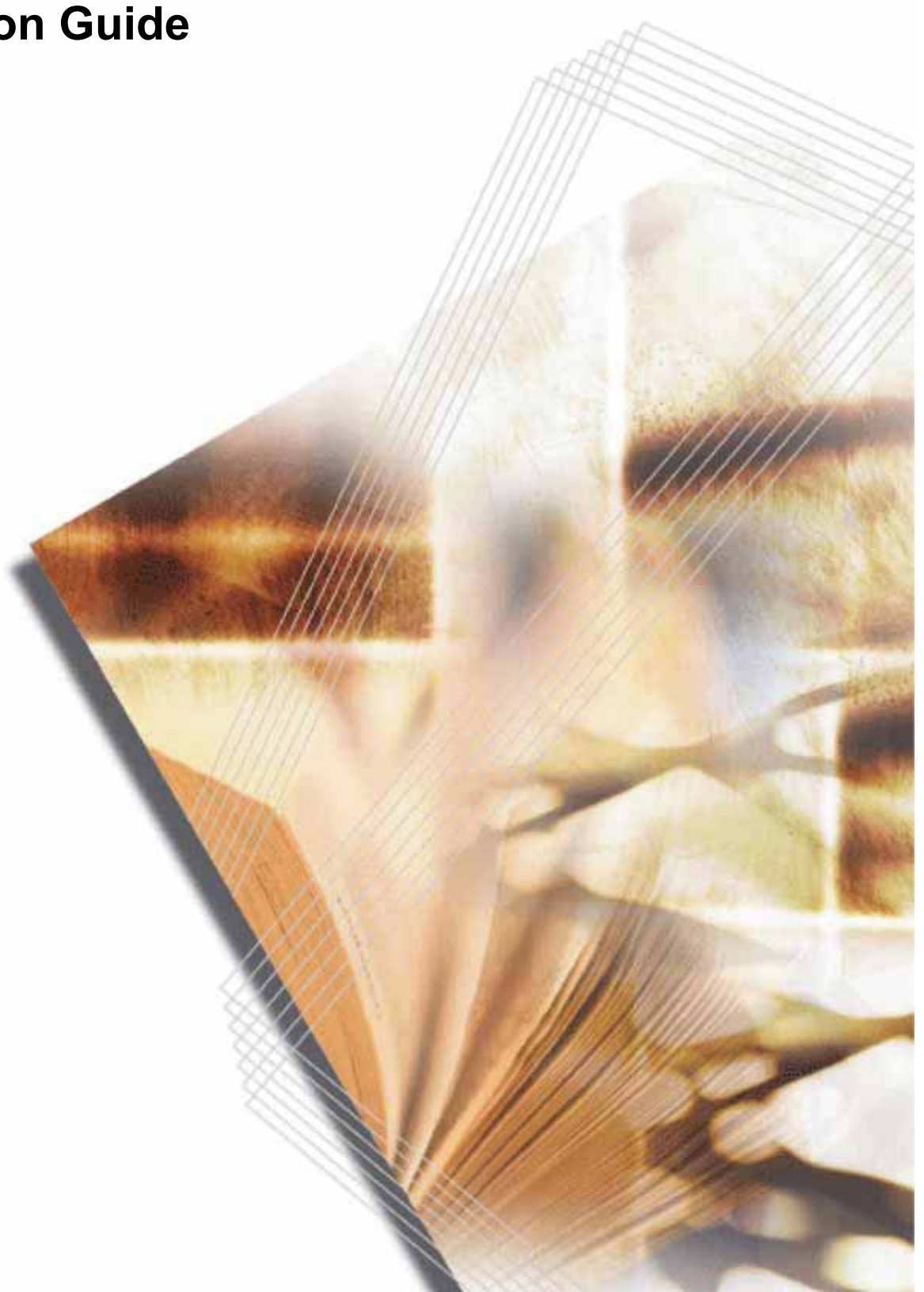

This Operation Guide is for models FS-1100 and FS-1300D.



**Note** This Operation Guide contains information that corresponds to using both the inch and metric versions of these machines.

The inch versions of these machines are shown in the screens in this guide. If you are using the metric version, use the messages provided for the inch version as reference only. In the body text, only the inch messages are given if these versions differ only in capitalization. When there is even a slight difference in the message, we have listed the information for the inch version followed, in brackets, by the corresponding information for the metric version.

## **Included Guides**

The following guides are included with this machine. Refer to the proper guide based on your requirements.

### **Operation Guide (This Guide)**

Describes how to load paper, print, replace toner, clean the printer, and troubleshooting.

### **Installation Guide**

Explains how to install this printer, as well as connecting cables and loading paper.

---

# Contents

---

<b>1</b>	<b>Machine Parts .....</b>	<b>1-1</b>
	<b>Components at the Front of the Printer .....</b>	<b>1-2</b>
	<b>Components at the Rear of the Printer .....</b>	<b>1-3</b>
	<b>Operation Panel .....</b>	<b>1-4</b>
	<b>Indicators .....</b>	<b>1-5</b>
	<b>Keys .....</b>	<b>1-6</b>
<b>2</b>	<b>Loading Paper .....</b>	<b>2-1</b>
	<b>General Guidelines .....</b>	<b>2-2</b>
	<b>Selecting the Right Paper .....</b>	<b>2-4</b>
	<b>Paper Type .....</b>	<b>2-10</b>
	<b>Preparing the Paper .....</b>	<b>2-11</b>
	<b>Loading Paper into Cassette .....</b>	<b>2-11</b>
	<b>Loading Paper into MP (Multi-Purpose)Tray .....</b>	<b>2-14</b>
<b>3</b>	<b>Connecting and Printing .....</b>	<b>3-1</b>
	<b>Connections .....</b>	<b>3-2</b>
	<b>Loading Software .....</b>	<b>3-3</b>
	<b>Printing .....</b>	<b>3-3</b>
	<b>Status Monitor .....</b>	<b>3-6</b>
	<b>Configuration Tool .....</b>	<b>3-9</b>
	<b>Uninstalling Software .....</b>	<b>3-13</b>
<b>4</b>	<b>Maintenance .....</b>	<b>4-1</b>
	<b>General Information .....</b>	<b>4-2</b>
	<b>Toner Container Replacement .....</b>	<b>4-2</b>
	<b>Cleaning the Printer .....</b>	<b>4-6</b>
	<b>Prolonged Non-Use and Moving the Printer .....</b>	<b>4-9</b>
<b>5</b>	<b>Troubleshooting .....</b>	<b>5-1</b>
	<b>General Guidelines .....</b>	<b>5-2</b>
	<b>Print Quality Problems .....</b>	<b>5-3</b>
	<b>Understanding Indicators .....</b>	<b>5-6</b>
	<b>Cleaning Paper Jams .....</b>	<b>5-10</b>
<b>6</b>	<b>Option .....</b>	<b>6-1</b>
	<b>General Information .....</b>	<b>6-2</b>
	<b>Expansion Memory Modules .....</b>	<b>6-3</b>
	<b>Removing a Memory Module .....</b>	<b>6-5</b>
	<b>PF-100 Paper Feeder .....</b>	<b>6-6</b>
	<b>Network Interface Card (IB-23) .....</b>	<b>6-7</b>
	<b>CompactFlash (CF) Card .....</b>	<b>6-8</b>
<b>7</b>	<b>Appendix .....</b>	<b>7-1</b>
	<b>Specifications .....</b>	<b>7-2</b>
	<b>Environmental Standard Requirements .....</b>	<b>7-3</b>
	<b>Index .....</b>	<b>Index-1</b>

---

---

# Legal and Safety Information

---

Please read this information before using your machine. This chapter provides information on the following topics:

<b>Legal Information</b>	<b>iv</b>
<b>License Agreements</b>	<b>vi</b>
<b>Safety Information</b>	<b>x</b>
<b>Symbols</b>	<b>xv</b>
<b>Installation Precautions</b>	<b>xvi</b>
<b>Precautions for Use</b>	<b>xviii</b>
<b>About the Operation Guide</b>	<b>xx</b>
<b>Conventions in This Guide</b>	<b>xxi</b>

---

# Legal Information

---



**CAUTION** NO LIABILITY IS ASSUMED FOR ANY DAMAGE CAUSED BY IMPROPER INSTALLATION.

## Notice on Software

SOFTWARE USED WITH THIS PRINTER MUST SUPPORT THE PRINTER'S EMULATION MODE. The printer is factory-set to emulate the PCL. The emulation mode can be changed.

## Notice

The information in this guide is subject to change without notification. Additional pages may be inserted in future editions.

The user is asked to excuse any technical inaccuracies or typographical errors in the present edition. No responsibility is assumed if accidents occur while the user is following the instructions in this guide. No responsibility is assumed for defects in the printer's firmware (contents of its read-only memory).

This guide, and any copyrightable subject matter sold or provided with or in connection with the sale of the page printer, are protected by copyright. All rights are reserved. Copying or other reproduction of all or part of this guide, or any copyrightable subject matter without the prior written consent of Kyocera Mita Corporation is prohibited. Any copies made of all or part of this guide, or any copyrightable subject must contain the same copyright notice as the material from which the copying is done.

## Regarding Tradenames

PRESCRIBE is a registered trademark of Kyocera Corporation. KPDL is trademark of Kyocera Corporation. Hewlett-Packard, PCL, and P JL are registered trademarks of Hewlett-Packard Company. Centronics is a trade name of Centronics Data Computer Inc. Adobe, Acrobat, Flash, and PostScript are registered trademarks of Adobe Systems Incorporated. Macintosh is a registered trademark of Apple Computer, Inc. Microsoft, Windows, and Windows NT are registered trademarks of Microsoft Corporation. Microsoft Windows Server is a trademark of Microsoft Corporation. PowerPC is a trademark of International Business Machines Corporation. CompactFlash is a trademark of SanDisk Corporation. ENERGY STAR is a U.S. registered mark. All other brand and product names are registered trademarks or trademarks of their respective companies.

This product uses PeerlessPrintXL to provide the HP LaserJet compatible PCL 6 language emulation. PeerlessPrintXL is a trademark of Peerless Systems Corporation, 2381 Rosecrans Ave. El Segundo, CA 90245, U.S.A.

This product was developed using the Tornado™ Real Time Operating System and Tools from Wind River Systems.

This product contains UFST™ and MicroTypeR from Monotype Imaging Inc.

---

## USB



This product has been certified by the USB Implementers Forum, Inc.

---

# License Agreements

---

## **IBM Program License Agreement**

THE DEVICE YOU HAVE PURCHASED CONTAINS ONE OR MORE SOFTWARE PROGRAMS ("PROGRAMS") WHICH BELONG TO INTERNATIONAL BUSINESS MACHINES CORPORATION ("IBM"). THIS DOCUMENT DEFINES THE TERMS AND CONDITIONS UNDER WHICH THE SOFTWARE IS BEING LICENSED TO YOU BY IBM. IF YOU DO NOT AGREE WITH THE TERMS AND CONDITIONS OF THIS LICENSE, THEN WITHIN 14 DAYS AFTER YOUR ACQUISITION OF THE DEVICE YOU MAY RETURN THE DEVICE FOR A FULL REFUND. IF YOU DO NOT SO RETURN THE DEVICE WITHIN THE 14 DAYS, THEN YOU WILL BE ASSUMED TO HAVE AGREED TO THESE TERMS AND CONDITIONS.

The Programs are licensed not sold. IBM, or the applicable IBM country organization, grants you a license for the Programs only in the country where you acquired the Programs. You obtain no rights other than those granted you under this license.

The term "Programs" means the original and all whole or partial copies of it, including modified copies or portions merged into other programs. IBM retains title to the Programs. IBM owns, or has licensed from the owner, copyrights in the Programs.

### **1. License**

Under this license, you may use the Programs only with the device on which they are installed and transfer possession of the Programs and the device to another party.

If you transfer the Programs, you must transfer a copy of this license and any other documentation to the other party. Your license is then terminated. The other party agrees to these terms and conditions by its first use of the Program.

You may not:

1. use, copy, modify, merge, or transfer copies of the Program except as provided in this license;
2. reverse assemble or reverse compile the Program; or
3. sublicense, rent, lease, or assign the Program.

### **2. Limited Warranty**

The Programs are provided "AS IS."

THERE ARE NO OTHER WARRANTIES COVERING THE PROGRAMS (OR CONDITIONS), EXPRESS OR IMPLIED, INCLUDING, BUT NOT LIMITED TO, THE IMPLIED WARRANTIES OF MERCHANTABILITY AND FITNESS FOR A PARTICULAR PURPOSE.

Some jurisdictions do not allow the exclusion of implied warranties, so the above exclusion may not apply to you.

### **3. Limitation of Remedies**

IBM's entire liability under this license is the following;

For any claim (including fundamental breach), in any form, related in any way to this license, IBM's liability will be for actual damages only and will be limited to the greater of:



- 
1. the equivalent of U.S. \$25,000 in your local currency; or
  2. IBM's then generally available license fee for the Program

This limitation will not apply to claims for bodily injury or damages to real or tangible personal property for which IBM is legally liable.

IBM will not be liable for any lost profits, lost savings, or any incidental damages or other economic consequential damages, even if IBM, or its authorized supplier, has been advised of the possibility of such damages. IBM will not be liable for any damages claimed by you based on any third party claim. This limitation of remedies also applies to any developer of Programs supplied to IBM. IBM's and the developer's limitations of remedies are not cumulative. Such developer is an intended beneficiary of this Section. Some jurisdictions do not allow these limitations or exclusions, so they may not apply to you.

#### **4. General**

You may terminate your license at any time. IBM may terminate your license if you fail to comply with the terms and conditions of this license. In either event, you must destroy all your copies of the Program. You are responsible for payment of any taxes, including personal property taxes, resulting from this license. Neither party may bring an action, regardless of form, more than two years after the cause of action arose. If you acquired the Program in the United States, this license is governed by the laws of the State of New York. If you acquired the Program in Canada, this license is governed by the laws of the Province of Ontario. Otherwise, this license is governed by the laws of the country in which you acquired the Program.

## **Typeface Trademark Acknowledgement**

All resident fonts in this printer are licensed from Monotype Imaging Inc. Helvetica, Palatino and Times are registered trademarks of Linotype-Hell AG. ITC Avant Garde Gothic, ITC Bookman, ITC ZapfChancery and ITC Zapf Dingbats are registered trademarks of International Typeface Corporation.

## **Monotype Imaging License Agreement**

1. "Software" shall mean the digitally encoded, machine readable, scalable outline data as encoded in a special format as well as the UFST Software.
2. You agree to accept a non-exclusive license to use the Software to reproduce and display weights, styles and versions of letters, numerals, characters and symbols ("Typefaces") solely for your own customary business or personal purposes at the address stated on the registration card you return to Monotype Imaging. Under the terms of this License Agreement, you have the right to use the Fonts on up to three printers. If you need to have access to the fonts on more than three printers, you need to acquire a multi-user license agreement which can be obtained from Monotype Imaging. Monotype Imaging retains all rights, title and interest to the Software and Typefaces and no rights are granted to you other than a License to use the Software on the terms expressly set forth in this Agreement.

- 
3. To protect proprietary rights of Monotype Imaging, you agree to maintain the Software and other proprietary information concerning the Typefaces in strict confidence and to establish reasonable procedures regulating access to and use of the Software and Typefaces.
  4. You agree not to duplicate or copy the Software or Typefaces, except that you may make one backup copy. You agree that any such copy shall contain the same proprietary notices as those appearing on the original.
  5. This License shall continue until the last use of the Software and Typefaces, unless sooner terminated. This License may be terminated by Monotype Imaging if you fail to comply with the terms of this License and such failure is not remedied within thirty (30) days after notice from Monotype Imaging. When this License expires or is terminated, you shall either return to Monotype Imaging or destroy all copies of the Software and Typefaces and documentation as requested.
  6. You agree that you will not modify, alter, disassemble, decrypt, reverse engineer or decompile the Software.
  7. Monotype Imaging warrants that for ninety (90) days after delivery, the Software will perform in accordance with Monotype Imaging-published specifications, and the diskette will be free from defects in material and workmanship. Monotype Imaging does not warrant that the Software is free from all bugs, errors and omissions.
  8. THE PARTIES AGREE THAT ALL OTHER WARRANTIES, EXPRESSED OR IMPLIED, INCLUDING WARRANTIES OF FITNESS FOR A PARTICULAR PURPOSE AND MERCHANTABILITY, ARE EXCLUDED.
  9. 9Your exclusive remedy and the sole liability of Monotype Imaging in connection with the Software and Typefaces is repair or replacement of defective parts, upon their return to Monotype Imaging.
  10. 10IN NO EVENT WILL MONOTYPE IMAGING BE LIABLE FOR LOST PROFITS, LOST DATA, OR ANY OTHER INCIDENTAL OR CONSEQUENTIAL DAMAGES, OR ANY DAMAGES CAUSED BY ABUSE OR MISAPPLICATION OF THE SOFTWARE AND TYPEFACES.
  11. Massachusetts U.S.A. law governs this Agreement.
  12. You shall not sublicense, sell, lease, or otherwise transfer the Software and/or Typefaces without the prior written consent of Monotype Imaging.
  13. Use, duplication or disclosure by the Government is subject to restrictions as set forth in the Rights in Technical Data and Computer Software clause at FAR 252-227-7013, subdivision (b)(3)(ii) or subparagraph (c)(1)(ii), as appropriate. Further use, duplication or disclosure is subject to restrictions applicable to restricted rights software as set forth in FAR 52.227-19 (c)(2).
  14. YOU ACKNOWLEDGE THAT YOU HAVE READ THIS AGREEMENT, UNDERSTAND IT, AND AGREE TO BE BOUND BY ITS TERMS AND CONDITIONS. NEITHER PARTY SHALL BE BOUND BY ANY STATEMENT OR REPRESENTATION NOT CONTAINED IN THIS AGREEMENT. NO CHANGE IN THIS AGREEMENT IS EFFECTIVE UNLESS WRITTEN AND SIGNED BY PROPERLY AUTHORIZED REPRESENTATIVES OF EACH PARTY. BY OPENING THIS DISKETTE PACKAGE, YOU AGREE TO ACCEPT THE TERMS AND CONDITIONS OF THIS AGREEMENT.

---

## Compliance and Conformity

### FCC Statement (for users in the United States and Canada)

This device complies with Part 15 of FCC Rules and RSS-Gen of IC Rules. Operation is subject to the following two conditions; (1) this device may not cause harmful interference, and (2) this device must accept any interference received, including interference that may cause undesired operation of the device.

This equipment has been tested and found to comply with the limits for a Class B digital device, pursuant to part 15 of the FCC Rules. These limits are designed to provide reasonable protection against harmful interference in a residential installation.

This equipment generates, uses and can radiate radio frequency energy and, if not installed and used in accordance with the instructions, may cause harmful interference to radio communications. However, there is no guarantee that interference will not occur in a particular installation. If this equipment does cause harmful interference to radio or television reception, which can be determined by turning the equipment off and on, the user is encouraged to try to correct the interference by one or more of the following measures:

- Reorient or relocate the receiving antenna.
- Increase the separation between the equipment and the receiver.
- Connect the equipment into an outlet on a circuit different from that to which the receiver is connected.
- Consult the dealer or an experienced radio/TV technician for help.

Changes or modifications not expressly approved by the party responsible for compliance could void the user's authority to operate the equipment.

Properly shielded grounded cables and connectors must be used for connection to host computer and/or peripherals in order to meet FCC emission limits.

### Precautions for Use

Any modifications without prior permission of Kyocera may cause harmful interference.

If any modifications or changes are made to this equipment without prior permission of Kyocera, Kyocera as the manufacturer does not guarantee the compliance with the FCC Rules. The use of equipment that does not comply with the FCC Rules is prohibited.

---

# Safety Information

---

## Laser Safety

This printer is certified as a Class 1 laser product under the U.S. Department of Health and Human Services (DHHS) Radiation Performance Standard according to Radiation Control for Health and Safety Act of 1968. This means that the printer does not produce hazardous laser radiation. Since radiation emitted inside the printer is completely confined within protective housings and external covers, the laser beam cannot escape from the printer during any phase of user operation.

## Laser Notice

This printer is certified in the U.S. to conform to the requirements of DHHS 21 CFR Subchapter for Class I (1) laser products, and elsewhere is certified as a Class I laser product conforming to the requirements of IEC 825.



**DANGER** CLASS 3B LASER RADIATION WHEN OPEN.  
AVOID DIRECT EXPOSURE TO BEAM.



**CAUTION** Use of controls or adjustments or performance of procedures other than those specified herein may result in hazardous radiation exposure.

## Radio Frequency Transmitter

This machine contains a transmitter module. We, the manufacturer (Kyocera Mita Corporation) hereby declare that this equipment (page printer), model FS-1100 and FS-1300D are in compliance with the essential requirements and other relevant provisions of Directive 1999/5/EC.

## Radio Tag Technology

In some countries, the radio tag technology used in this equipment to identify the toner container may be subject to authorization, and the use of this equipment may consequently be restricted.

# Caution Labels

The printer bears any of the following labels.

**Laser inside the printer  
(Laser radiation warning)**

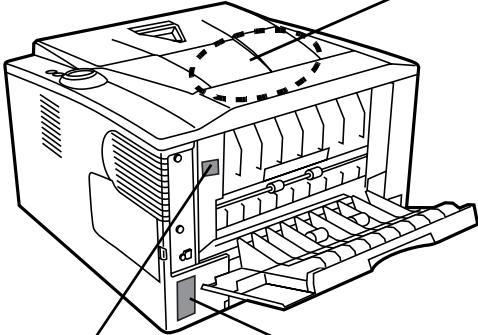

**DANGER** • CLASS 3B INVISIBLE LASER RADIATION WHEN OPEN. AVOID DIRECT EXPOSURE TO BEAM.

**ATTENTION** • CLASSE 3B RAYONNEMENT LASER INVISIBLE EN CAS D'OUVERTURE. EXPOSITION DANGEREUSE AU FAISCEAU.

**VORSICHT** • KLASSE 3B UNSICHTBARE LASERSTRAHLUNG, WENN ABDECKUNG GEÖFFNET. NICHT DEM STRAHL AUSSETZEN.

**ATTENZIONE** • CLASSE 3B RADIAZIONE LASER INVISIBLE IN CASO DI APERTURA. EVITARE L'ESPOSIZIONE AL FASCIO.

**PRECAUCION** • CLASSE 3B RADIACIONE LASER INVISIBLE CUANDO SE ABRE. EVITAR EXPOSICION AL RAYO.

**VARO!** • AVATTAESSA OLET ALTTIINA LUOKAN 3B NÄKYMÄTTÖMÄLLE LASERSÄTELYLLE. ÄLÄ KATSO SÄTEESEEN.

**警告** • 该产品为3B类不可见激光产品。打开盖子后会有激光辐射。请避免光束照射。

**警告** • 該產品為3B類不可見激光產品。打開蓋子後會有激光輻射。請避免光束照射。

**위험** • CLASS 3B 레이저광선을 직접 보지마십시오.

**警告** • ここを覗くとクラス3B不可視レーザー光が射します。ビームを直接見たり、触れないでください。

**For Europe, Asia, and other countries**

**CAUTION**  
HOT SURFACE  
**ACHTUNG**  
HEISSE OBERFLÄCHE  
**ATTENTION**  
TEMPÉRATURE ÉLEVÉE  
**ATTENCIÓN**  
EXTERIOR CALIENTE  
**ATTENZIONE**  
SUPERFICIE CHE SCOTIA  
高温注意  
고온주의



**For U.S.A. and Canada**

**FS-1100** AC 220-240V 50/60Hz 3.9A  
KYOCERA MITA Corporation

- Apparat mit freies jords stikkontakt.
- Apparatet skall anslutas till jordat uttag.
- Laite on liitettyä suojamaadotuskeskittimä varustettuun pistoraasiaan.



AD7035344  
-REMOVE POWER CORD BEFORE SERVICE.  
-VOR WARTUNG BITTE NETZSTECKER ZIEHEN.  
-POUR PRIÉRIÈRE LES CHOCS ÉLECTRIQUES, COUPER L'ALIMENTATION AVANT DE MANIPULER.  
-DESIGNARIFE EL CORDÓN DE ALIMENTACIÓN ANTES DEL SERVICIO.  
-PRIMA DI ESEGUIRE RIPARAZIONE, STACCARE IL CAVO DI ALIMENTAZIONE.  
-ABS- DESIGNED IN JAPAN / ASSEMBLED IN CHINA

**FS-1300D** AC 220-240V 50/60Hz 3.9A  
KYOCERA MITA Corporation

- Apparat mit freies jords stikkontakt.
- Apparatet skall anslutas till jordat uttag.
- Laite on liitettyä suojamaadotuskeskittimä varustettuun pistoraasiaan.



AD7035344  
-REMOVE POWER CORD BEFORE SERVICE.  
-VOR WARTUNG BITTE NETZSTECKER ZIEHEN.  
-POUR PRIÉRIÈRE LES CHOCS ÉLECTRIQUES, COUPER L'ALIMENTATION AVANT DE MANIPULER.  
-DESIGNARIFE EL CORDÓN DE ALIMENTACIÓN ANTES DEL SERVICIO.  
-PRIMA DI ESEGUIRE RIPARAZIONE, STACCARE IL CAVO DI ALIMENTAZIONE.  
-ABS- DESIGNED IN JAPAN / ASSEMBLED IN CHINA

## CDRH Regulations

The Center for Devices and Radiological Health (CDRH) of the U.S. Food and Drug Administration implemented regulations for laser products on August 2, 1976. These regulations apply to laser products manufactured after August 1, 1976. Compliance is mandatory for products marketed in the United States. A label indicating compliance with the CDRH regulations must be attached to laser products marketed in the United States.

## Ozone Concentration

These printers generate ozone gas (O<sub>3</sub>), which may concentrate in the place of installation and cause an unpleasant smell. To minimize the concentration of ozone gas to less than 0.1ppm, we recommend you not to install the printer in a confined area where ventilation is blocked.

xi

---

## Declaration of Conformity for U.S.A.

Model name: Page Printer FS-1100 and FS-1300D

Trade name: Kyocera Mita

Responsible party: Kyocera Mita America, Inc.

Address: 225 Sand Road PO Box 40008 Fairfield, New Jersey 07004-0008, U.S.A.

Telephone: (973) 808-8444

Fax: (973) 882-6000

Manufacturer: Kyocera Mita Corporation

Manufacturer's address: 2-28, 1-Chome, Tamatsukuri, Chuo-ku, Osaka, 540-8585, Japan

This device complies with Part 15 of the FCC Rules. Operation is subject to the following two conditions: (1) this device may not cause harmful interference, and (2) this device must accept any interference received, including interference that may cause undesired operation.

The manufacturer and its merchandising companies retain the following technical documentation in anticipation of the inspection that may be conducted by the authorities concerned:

User's instruction that conforms to the applicable specifications.

Technical drawings.

Descriptions of the procedures that guarantee the conformity.

Other technical information.

Kyocera Mita America Inc.

## CE Marking Directive

Hereby, Kyocera Mita Corporation, declares that this page printer is in compliance with the essential requirements and other relevant provisions of Directive 1999/5/EC.

According to Council Directive 89/336/EEC, 2006/95/EC, and 1999/5/EC

Manufacturer: Kyocera Mita Corporation

Manufacturer's address: 2-28, 1-Chome, Tamatsukuri, Chuo-ku, Osaka, 540-8585, Japan

Declares that the product

Product name: Page Printer

Model number: FS-1100 and FS-1300D (as tested with enhancement optional unit; Paper Feeder PF-100)

Conforms to the following product specifications:

EN 55 022:1998+A1:2000+A2:2003 Class B

EN 61 000-3-2:2000

EN 61 000-3-3:1995+A1:2001

EN 55 024:1998+A1:2001+A2:2003

EN 60 950-1:2001+A11

EN 60 825-1:1994+A1+A2

EN 300330-1

EN 300330-2

---

The manufacturer and its merchandising companies retain the following technical documentation in anticipation of the inspection that may be conducted by the authorities concerned:

User's instruction that conforms to the applicable specifications.

Technical drawings.

Descriptions of procedures that guarantee conformity.

Other technical information.

## **Declaration of Conformity (Australia)**

Manufacturer: Kyocera Mita Corporation

Manufacturer's address: 2-28, 1-Chome, Tamatsukuri, Chuo-ku, Osaka, 540-8585, Japan

declares that the product

Product name: Page Printer

Model name: FS-1100 and FS-1300D

Description of devices: This Page Printer Model FS-1100 and FS-1300D are 28ppm; A4 size and utilizes plain paper; dry toner; etc. The printer can be equipped with several optional enhancement units, such as a PF-100 paper feeder.

conforms to the following product specifications:

AS/NZS 3548: 1995 (EN 55 022: 1998 Class B)

AS/NZS 4268: 2003

IEC60950-1:2001 (EN 60 950-1: 2001+A11)

The manufacturer and its merchandising companies retain the following technical documentation in anticipation of the inspection that may be conducted by the authorities concerned:

User's instruction that conforms to the applicable specifications

Technical drawings

Descriptions of procedures that guarantee conformity

Other technical information

The manufacturer has been employed with ISO9001 scheme. JQA and BS have attested the manufacturer.

Kyocera Mita Australia Pty., Ltd.

6-10 Talavera Road, North Ryde, NSW 2113, Australia

Telephone: +61 2-9888-9999

Fax: +61 2-9888-9588

## **Canadian Department of Communications Compliance Statement**

This Class B digital apparatus complies with Canadian ICES-003.

## **Avis de conformité aux normes du ministère des Communications du Canada**

Cet appareil numérique de la classe B est conforme à la norme NMB-003 du Canada.

---

## EN ISO 7779

Maschinenlärminformationsverordnung 3. GSGV, 18.01.1991: Der höchste Schalldruckpegel beträgt 70 dB (A) oder weniger gemäß EN ISO 7779.

## Disclaimer

Kyocera Mita will not be liable to customers or any other person or entity for any loss or damage caused or alleged to be caused directly or indirectly by equipment sold or furnished by us, including but not limited to, any interruption of service, loss of business or anticipatory profits, or consequential damages resulting from the use or operation of the equipment or software.

## Energy Saving Function

This printer comes equipped with a Sleep Mode where printer function remains in a waiting state but power consumption is still reduced to a minimum when there is no activity with the printer within a set amount of time.

### Sleep Mode

This printer automatically enters Sleep Mode when approximately 15 minutes have passed since the printer was last used. The amount of time of no activity that must pass before Sleep Mode is activated may be lengthened.

## Duplex Printing

This printer includes duplex printing as a standard function. For example, by printing two single-sided originals onto a single sheet of paper as a duplex printing, it is possible to lower the amount of paper used.

## Recycled Paper

This printer supports recycled paper which reduces the load on the environment. Your sales or service representative can provide information about recommended paper types.

## Energy Star (ENERGY STAR®) Program



We have determined as a participating company in the International Energy Star Program that this product is compliant with the standards laid out in the International Energy Star Program.



---

# Symbols

---

The sections of this guide and parts of the machine marked with symbols are safety warnings meant to protect the user, other individuals and surrounding objects, and ensure correct and safe usage of the machine. The symbols and their meanings are indicated below.



**DANGER:** Indicates that serious injury or even death will very possibly result from insufficient attention to or incorrect compliance with the related points.



**WARNING:** Indicates that serious injury or even death may result from insufficient attention to or incorrect compliance with the related points.



**CAUTION:** Indicates that personal injury or mechanical damage may result from insufficient attention to or incorrect compliance with the related points.

The following symbols indicate that the related section includes safety warnings. Specific points of attention are indicated inside the symbol.



.... [General warning]



.... [Warning of danger of electrical shock]



.... [Warning of high temperature]

The following symbols indicate that the related section includes information on prohibited actions. Specifics of the prohibited action are indicated inside the symbol.



.... [Warning of prohibited action]



.... [Disassembly prohibited]

The following symbols indicate that the related section includes information on actions which must be performed. Specifics of the required action are indicated inside the symbol.



.... [Alert of required action]



.... [Remove the power plug from the outlet]



.... [Always connect the machine to an outlet with a ground connection]

Please contact your service representative to order a replacement if the safety warnings in this Operation Guide are illegible or if the guide itself is missing. (fee required)

---

# ⚠ Installation Precautions

---

## Environment

### ⚠ Caution

Avoid placing the machine on or in locations which are unstable or not level. Such locations may cause the machine to fall down or fall over. This type of situation presents a danger of personal injury or damage to the machine.



Avoid locations with humidity or dust and dirt. If dust or dirt become attached to the power plug, clean the plug to avoid the danger of fire or electrical shock.



Avoid locations near radiators, heaters, or other heat sources, or locations near flammable items, to avoid the danger of fire.



To keep the machine cool and facilitate changing of parts and maintenance, allow access space as shown below. Leave adequate space, especially around the rear cover, to allow air to be properly ventilated out of the printer.

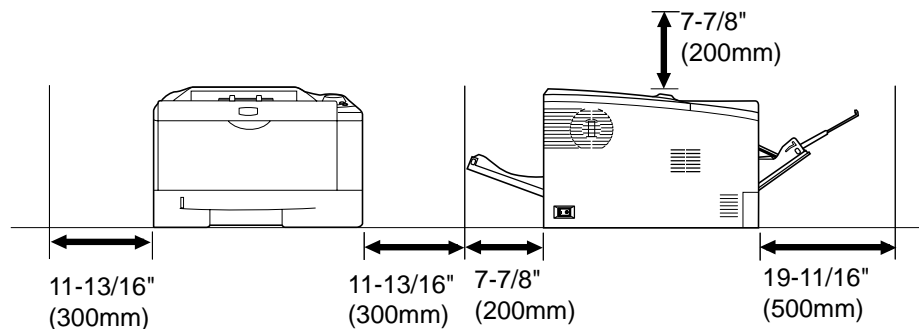

## Other Precautions

Adverse environmental conditions may affect the safe operation and performance of the machine. Install in an air-conditioned room (recommended room temperature: around 23°C (73.4°F), humidity: around 60% RH), and avoid the following locations when selecting a site for the machine.

- Avoid locations near a window or with exposure to direct sunlight.
- Avoid locations with vibrations.
- Avoid locations with drastic temperature fluctuations.
- Avoid locations with direct exposure to hot or cold air.
- Avoid poorly ventilated locations.

During printing, some ozone is released, but the amount does not cause any ill effect to one's health. If, however, the printer is used over a long period of time in a poorly ventilated room or when printing an extremely large number of copies, the smell may become unpleasant. To maintain the appropriate environment for print work, it is suggested that the room be properly ventilated.

---

## Power Supply/Grounding the Machine

### Warning

Do not use a power supply with a voltage other than that specified. Avoid multiple connections in the same outlet. These types of situations present a danger of fire or electrical shock.



Plug the power cord securely into the outlet. If metallic objects come in contact with the prongs on the plug, it may cause a fire or electric shock.



Always connect the machine to an outlet with a ground connection to avoid the danger of fire or electrical shock in case of an electric short. If an earth connection is not possible, contact your service representative.



### Other precautions

Connect the power plug to the closest outlet possible to the machine.

The power supply cord is used as the main disconnect device. Ensure that the socket/outlet is located/installed near the equipment and is easily accessible.

## Handling of plastic bags

### Warning

Keep the plastic bags that are used with the machine away from children. The plastic may cling to their nose and mouth causing suffocation.



---

# Precautions for Use

---

## Cautions when using the machine

### Warning

Do not place metallic objects or containers with water (flower vases, flower pots, cups, etc.) on or near the machine. This situation presents a danger of fire or electrical shock should they fall inside.



Do not remove any of the covers from the machine as there is a danger of electrical shock from high voltage parts inside the machine.



Do not damage, break or attempt to repair the power cord. Do not place heavy objects on the cord, pull it, bend it unnecessarily or cause any other type of damage. These types of situations present a danger of fire or electrical shock.



Never attempt to repair or disassemble the machine or its parts as there is a danger of fire, electrical shock or damage to the laser. If the laser beam escapes, there is a danger of it causing blindness.



If the machine becomes excessively hot, smoke appears from the machine, there is an odd smell, or any other abnormal situation occurs, there is a danger of fire or electrical shock. Turn the main power switch off (O) immediately, be absolutely certain to remove the power plug from the outlet and then contact your service representative.



If anything harmful (paper clips, water, other fluids, etc.) falls into the machine, turn the main power switch off (O) immediately. Next, be absolutely certain to remove the power plug from the outlet to avoid the danger of fire or electrical shock. Then contact your service representative.



Do not remove or connect the power plug with wet hands, as there is a danger of electrical shock.



Always contact your service representative for maintenance or repair of internal parts.



### Caution

Do not pull the power cord when removing it from the outlet. If the power cord is pulled, the wires may become broken and there is a danger of fire or electrical shock. (Always grasp the power plug when removing the power cord from the outlet.)



Always remove the power plug from the outlet when moving the machine. If the power cord is damaged, there is a danger of fire or electrical shock.



If the machine will not be used for a short period of time (overnight, etc.), turn the power switch off (O). If it will not be used for an extended period of time (vacations, etc.), remove the power plug from the outlet for safety purposes during the time the machine is not in use..



Always hold the designated parts only when lifting or moving the machine.



For safety purposes, always remove the power plug from the outlet when performing cleaning operations.



---

If dust accumulates within the machine, there is a danger of fire or other trouble. It is therefore recommended that you consult with your service representative in regard to cleaning of internal parts. This is particularly effective if accomplished prior to seasons of high humidity. Consult with your service representative in regard to the cost of cleaning the internal parts of the machine.



### Other precautions

Do not place heavy objects on the machine or cause other damage to the machine.

Do not open the upper front cover, turn off the main power switch, or pull out the power plug during printing.

When lifting or moving the machine, contact your service representative.

Do not touch electrical parts, such as connectors or printed circuit boards. They could be damaged by static electricity.

Do not attempt to perform any operations not explained in this handbook.

Use shielded interface cables.

### **Caution**

Use of controls or adjustments or performance of procedures other than those specified herein may result in hazardous radiation exposure.

### Cautions when Handling Consumables

### **Caution**

Do not attempt to incinerate the Toner Container. Dangerous sparks may cause burns.



Keep the Toner Container out of the reach of children.



If toner happens to spill from the Toner Container, avoid inhalation and ingestion, as well as contact with your eyes and skin.



- If you do happen to inhale toner, move to a place with fresh air and gargle thoroughly with a large amount of water. If coughing develops, contact a physician.
- If you do happen to ingest toner, rinse your mouth out with water and drink 1 or 2 cups of water to dilute the contents of your stomach. If necessary, contact a physician.
- If you do happen to get toner in your eyes, flush them thoroughly with water. If there is any remaining tenderness, contact a physician.
- If toner does happen to get on your skin, wash with soap and water.

Do not attempt to force open or destroy the Toner Container.



### Other precautions

After use, always dispose of the Toner Container in accordance with Federal, State and Local rules and regulations.

Store all consumables in a cool, dark location.

If the machine will not be used for an extended period of time, remove the paper from the cassette, return it to its original package and reseal it.

---

## About the Operation Guide

This Operation Guide contains the following chapters:

### **1 Machine Parts**

This chapter explains the names of parts.

### **2 Loading Paper**

This chapter explains how to load paper into your printer.

### **3 Printing**

This chapter explains how to print from your PC.

### **4 Maintenance**

This chapter explains how to replace the toner container and how to care for your printer.

### **5 Troubleshooting**

This chapter explains how to handle printer problems that may occur, such as paper jams.

### **6 Options**

This chapter explains the options for this printer.

### **7 Specifications**

This chapter lists the printer's specifications.

---

## Conventions in This Guide

This manual uses the following conventions.

Convention	Description	Example
<b>Italic Typeface</b>	Used to emphasize a key word, phrase or reference to additional information.	Close the <i>front cover</i> . Refer to <i>Toner Container Replacement</i> on page 3-3.
<b>Bold</b>	Used to denote operation panel keys.	Press <b>[GO]</b> . To start printing, click <b>OK</b> .
<b>Note</b>	Used to provide additional or useful information about a function or feature.	 <b>Note</b> For information about storing the pin, refer to step 10.
<b>Important</b>	Used to provide important information.	<b>IMPORTANT</b> Ensure paper is not folded, curled, or damaged.
<b>Caution</b>	Cautions are statements that suggest <i>mechanical</i> damage as a result of an action.	<b>CAUTION</b> For safety, always unplug the power cord before cleaning the machine.
<b>Warning</b>	Used to alert users to the possibility of personal injury.	<b>WARNING</b> High voltage is present in the charger section.





---

# 1 Machine Parts

---

This chapter identifies machine parts and operation panel keys.

<b>Components at the Front of the Printer</b>	<b>1-2</b>
<b>Components at the Rear of the Printer</b>	<b>1-3</b>
<b>Operation Panel</b>	<b>1-4</b>
<b>Indicators</b>	<b>1-5</b>
<b>Keys</b>	<b>1-6</b>

---

## Components at the Front of the Printer

FS-1100

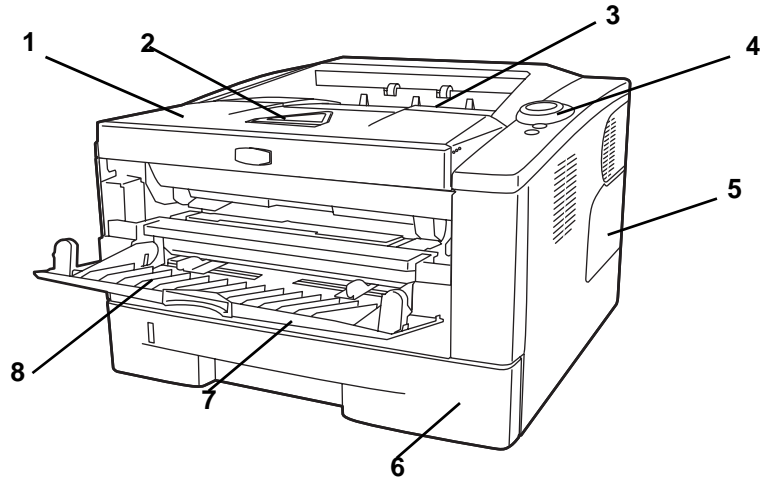

FS-1300D

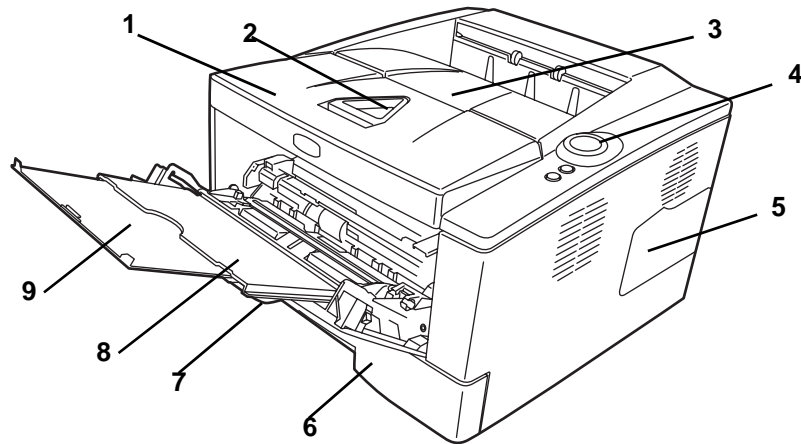

- 1 Top Cover
- 2 Paper Stopper
- 3 Top Tray
- 4 Operation Panel
- 5 Right Cover
- 6 Paper Cassette
- 7 Front Cover
- 8 MP Tray
- 9 Subtray

---

## Components at the Rear of the Printer

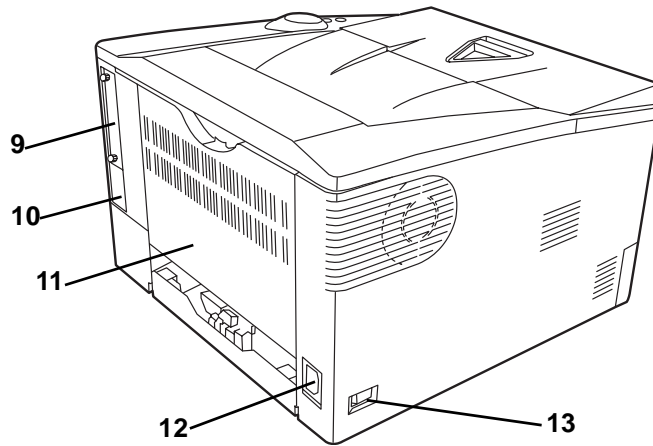

- 10** Optional Interface Slot Cover
- 11** USB Interface Connector
- 12** Rear Cover
- 13** Power Cord Connector
- 14** Power Switch



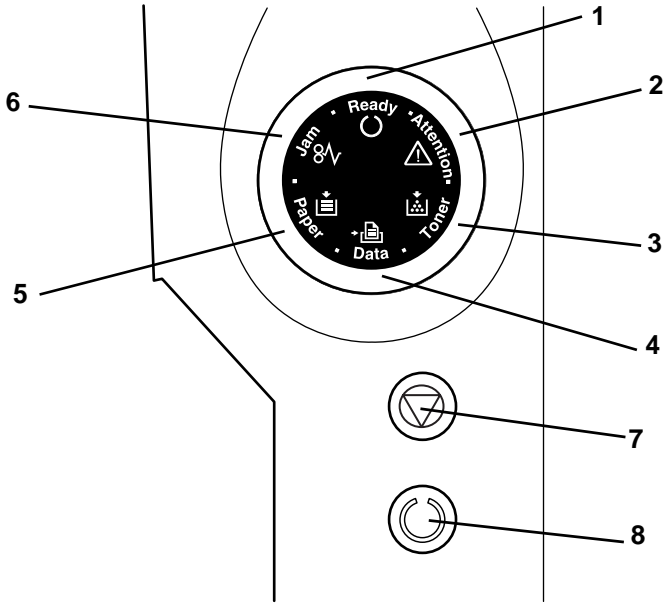



# Operation Panel



- 1 **Ready** Indicator
- 2 **Attention** Indicator
- 3 **Toner** Indicator
- 4 **Data** Indicator
- 5 **Paper** Indicator
- 6 **Jam** Indicator
- 7 **[Cancel]** Key
- 8 **[GO]** Key

## Indicators

There are six indicators located on the top right of the printer. The indicators are used to identify the status of the printer at any time. To identify the printer status, check the indicators on the printer and then refer to the table below.

Indicator	Status	Meaning
	Lit	Indicates online status (printing is possible).
	Fast Flashing	Offline status. You cannot print, but the printer can receive data.
	Slow Flashing	The printer is in sleep mode. Printing resumes when the [GO] is pressed.
	Off	The printer has stopped because an error occurred.
	Lit	The printer is processing data or is accessing to memory.
	Fast Flashing	The printer is receiving data.
	Off	The printer is not processing data.
	Lit	A paper jam has occurred or the cassette is not inserted properly.
	Off	The printer status is normal.
	Lit	The paper has run out when printing.
	Fast Flashing	The specified cassette or paper feeder has no paper at Ready status. The cassette is not inserted properly.
	Off	The printer status is normal.
	Lit	An error has occurred because the printer cover is open, but printing resumes when the [GO] is pressed. While an optional feeder is installed and the feeder is selected as a paper source, the paper cassette of the main unit (CASS1) is not installed correctly.
	Fast Flashing	The warning status other than Jam, Toner, Paper, and Attention.
	Off	The printer status is normal.
	Lit	The printer has stopped because the toner is exhausted.
	Fast Flashing	The toner is running low.
	Off	The printer status is normal.



**Note** For other combinations of the six indicators, call for service. Status Monitor (software bundled with the KX driver) will provide more detailed information about the printer status.

---

## Keys

Refer to the following table for the name and description of the basic functions of each key.

Key	Status	Operation	Function
Cancel	-	Press for 1 second or more	Cancels the data from the PC
GO	At Ready	Press momentarily	Switches On-line/Off-line
		Press for 3 to 10 seconds	The printer is in sleep mode. Printing resumes when the [GO] is pressed.
		Press for 10 seconds or more	The printer has stopped because an error occurred.
	At Error	Press momentarily	The printer is processing data or is accessing to memory.
Paper Empty	Press momentarily	The printer status is normal.	

---

## 2 Loading Paper

---

This chapter explains the preparations required before using the machine.

<b>Paper Specifications</b>	<b>2-2</b>
<b>Preparing the Paper</b>	<b>2-11</b>
<b>Loading Paper into Cassette</b>	<b>2-11</b>
<b>Loading Paper into MP (Multi-Purpose)Tray</b>	<b>2-14</b>

---

## General Guidelines

The machine is designed to print on standard copier paper, but it can also accept a variety of other types of paper within the limits specified below.



**Note** The manufacturer assumes no liability for problems that occur when paper not satisfying these requirements is used.

Selection of the right paper is important. Using the wrong paper can result in paper jams, curling, poor print quality, and paper waste, and in extreme cases can damage the machine. The guidelines given below will increase the productivity of your office by ensuring efficient, trouble-free printing and reducing wear and tear on the machine.

## Paper Availability

Most types of paper are compatible with a variety of machines. Paper intended for xerographic copiers can also be used with the machine.

There are three general grades of paper: economy, standard, and premium. The most significant difference between grades is the ease with which they pass through the machine. This is affected by the smoothness, size, and moisture content of the paper, and the way in which the paper is cut. The higher the grade of paper you use, the less risk there will be of paper jams and other problems, and the higher the level of quality your printed output will reflect.

Differences between paper from different suppliers can also affect the machine's performance. A high-quality printer cannot produce high-quality results when the wrong paper is used. Low-priced paper is not economical in the long run if it causes printing problems.

Paper in each grade is available in a range of basis weights (defined later). The traditional standard weights are 60 to 120 g/m<sup>2</sup> (16 to 31.9b).

## Paper Specifications

The following table summarizes the basic paper specifications. Details are given on the following pages:

Item	Specifications
Weight	Cassette: 60 to 120 g/m <sup>2</sup> (16 to 31.9 lb/ream) MP tray: 60 to 220 g/m <sup>2</sup> (16 to 58.5 lb/ream)
Thickness	0.086 to 0.110mm (3.4 to 4.3 mils)
Dimensional Accuracy	±0.7 mm (±0.0276 inches)
Squareness of Corners	90±0.2°
Moisture Content	4 to 6%
Direction of Grain	Long grain
Pulp Content	80% or more



## Minimum and Maximum Paper Sizes

The minimum and maximum paper sizes are as follows. For the paper smaller than JIS B6, postcards, and envelopes, the MP tray must be used.

Paper cassette

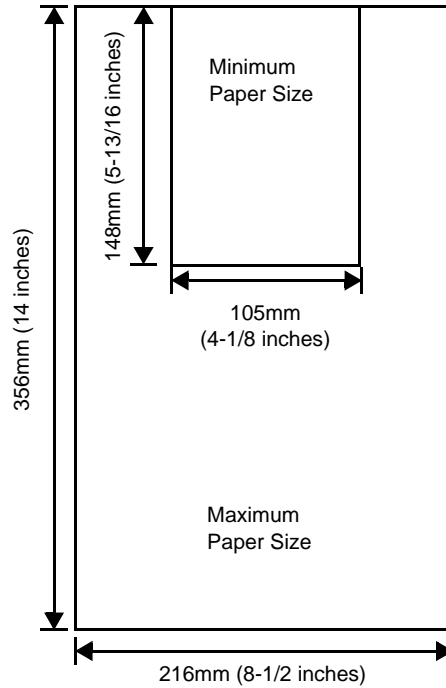

MP tray

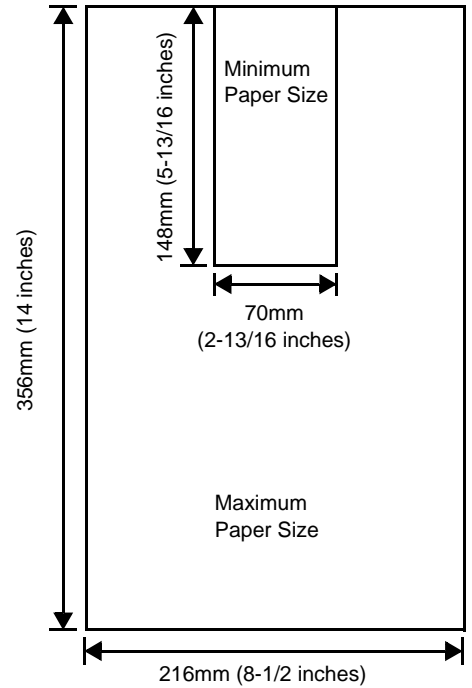

**Note** The minimum paper size of the optional paper feeder (PF-100) is 148 x 210 mm (5-13/16 x 8-5/16 inches).

---

## Selecting the Right Paper

This section describes the guidelines for selecting paper.

### Condition

Avoid using paper that is bent at the edges, curled, dirty, torn, embossed, or contaminated with lint, clay, or paper shreds.

Use of paper in these conditions can lead to illegible printing and paper jams, and can shorten the life of the machine. In particular, avoid using paper with a surface coating or other surface treatment. Paper should have as smooth and even a surface as possible.

### Composition

Do not use paper that has been coated or surface-treated and contains plastic or carbon. The heat of fusing can cause such paper to give off harmful fumes.

Bond paper should contain at least 80% pulp. Not more than 20% of the total paper content should consist of cotton or other fibers.

### Paper Sizes

*Cassettes* and the *MP Tray* are available for the paper sizes listed in the table below. The dimensional tolerances are  $\pm 0.7\text{mm}$  for the length and width. The angle at the corners must be  $90^\circ \pm 0.2^\circ$ .

MP Tray:

Envelope Monarch, Envelope #10, Envelope #9, Envelope #6, Envelope C5, Envelope DL, Legal, Letter-R, Statement, Oficio II, Executive, ISO A4-R, ISO A5, ISO A6, Folio, ISO B5-R, JIS B5-R, JIS B6, Hagaki, Ofuku-Hagaki, Youkei 2, Youkei 4, 16 kai, Custom (70 x 148 to 216 x 356mm (2-13/16 x 5-13/16 to 8-1/2 x 14 inches))



**Note** If the length of custom paper is larger than 297mm, you can load the standard-size paper from Folio to Letter.

Cassette:

Legal, Letter-R, Statement, Oficio II, Executive, ISO A4-R, ISO A5, A6 (only for machine's paper cassette), Folio, ISO B5-R, JIS B5-R, Envelope C5, 16 kai, Custom (Paper Cassette: 105 x 148 to 216 x 356mm (4-1/8 x 5-13/16 to 8-1/2 x 14 inches), Paper Feeder: 148 x 210 to 216 x 356mm (5-13/16 x 8-5/16 to 8-1/2 x 14 inches))



**Note** If the length of custom paper is larger than 297mm, you can load the standard-size paper from Folio to Legal.

### Smoothness

The paper should have a smooth, uncoated surface. Paper with a rough or sandy surface can cause blank spaces in the printed output. Paper that is too smooth can cause multiple feeding and fogging problems. (Fogging is a gray background effect.)

---

## Basis weight

Basis weight is the weight of paper expressed in grams per square meter (g/m<sup>2</sup>). Paper that is too heavy or too light may cause feed errors or paper jams as well as premature wear of the product. Uneven weight of paper, namely uneven paper thickness may cause multiple-sheet feeding or print quality problems such as blurring because of poor toner fusing.

The recommended basis weight is between 60 and 120g/m<sup>2</sup> (16 to 31.9 lib/ream) for the cassette and between 60 and 220g/m<sup>2</sup> (16 to 59 lib/ream) for the MP tray.

## Paper Weight Equivalence Table

The paper weight is listed in pounds (lb) and metric grams per square meter (g/m<sup>2</sup>). The shaded part indicates the standard weight.

U. S. Bond Weight (lb)	Europe Metric Weight (g/m <sup>2</sup> )
16	60
17	64
20	75
21	80
22	81
24	90
27	100
28	105
32	120
34	128
36	135
39	148
42	157
43	163
47	176
53	199

## Thickness

The paper used with the machine should be neither extremely thick nor extremely thin. If you are having problems with paper jams, multiple feeds, and faint printing, the paper you are using may be too thin. If you are having problems with paper jams and blurred printing the paper may be too thick. The correct thickness is 0.086 to 0.110mm (3.4 to 4.3 mils).

## Moisture Content

Moisture content is defined as the percent ratio of moisture to the dry mass of the paper. Moisture can affect the paper's appearance, feed ability, curl, electrostatic properties, and toner fusing characteristics.

---

The moisture content of the paper varies with the relative humidity in the room. When the relative humidity is high and the paper absorbs moisture, the paper edges expand, becoming wavy in appearance. When the relative humidity is low and the paper loses moisture, the edges shrink and tighten, and print contrast may suffer.

Wavy or tight edges can cause jams and alignment anomalies. The moisture content of the paper should be 4 to 6%.

To ensure correct moisture content, it is important to store the paper in a controlled environment. Some tips on moisture control are:

- Store paper in a cool, dry location.
- Keep the paper in its wrapping as long as possible. Re-wrap paper that is not in use.
- Store paper in its original carton. Place a pallet etc. under the carton to separate it from the floor.
- After removing paper from storage, let it stand in the same room as the machine for 48 hours before use.
- Avoid leaving paper where it is exposed to heat, sunlight, or damp.

## Paper Grain

When paper is manufactured, it is cut into sheets with the grain running parallel to the length (long grain) or parallel to the width (short grain). Short grain paper can cause feeding problems in the machine. All paper used in the machine should be long grain.

## Other Paper Properties

**Porosity:** Indicates the density of paper fiber.

**Stiffness:** Limp paper may buckle in the machine, resulting in paper jams.

**Curl:** Most paper naturally tends to curl one way if left unpacked. When paper passes through the fixing unit, it curls upward a little. To produce flat printouts, load the paper so that the upward pressure from the machine can correct their curling.

**Electrostatic discharge:** During the printing process the paper is electrostatically charged to attract the toner. The paper must be able to release this charge so that printed sheets do not cling together in the *Output Tray*.

**Whiteness:** The contrast of the printed page depends on the whiteness of the paper. Whiter paper provides a sharper, brighter appearance.

**Quality control:** Uneven sheet size, corners that are not square, ragged edges, welded (uncut) sheets, and crushed edges and corners can cause the machine to malfunction in various ways. A quality paper supplier should take considerable care to ensure that these problems do not occur.

**Packaging:** Paper should be packed in a sturdy carton to protect it from damage during transport. Quality paper obtained from a reputable supplier is usually correctly packaged.

---

## Special Paper

The following types of special paper can be used:

- Thin paper (60 to 64 g/m<sup>2</sup>)
- Thick paper (90 to 220 g/m<sup>2</sup>)
- Colored paper
- Recycled paper
- Overhead projector transparencies
- Cardstock
- Coated paper
- Envelopes
- Labels

Use paper that is sold specifically for use with copiers or printers (heat-fusing type). When using transparencies, labels, envelopes, cardstock, coated, or thick paper, feed the paper from the *MP Tray*.

Since the composition and quality of special paper vary considerably, special paper is more likely than white bond paper to give trouble during printing. No liability will be assumed if moisture and so forth given off during printing on special paper causes harm to the machine or operator.



**Note** Before purchasing any type of special paper, test a sample on the machine and check that printing quality is satisfactory.

### Transparency

This printer is available for monochrome printing on transparencies. Transparencies must be fed to the *MP Tray*. One transparency can be loaded at a time.

Transparencies must be able to withstand the heat of fusing during the printing process.

Transparencies must be placed on the *MP tray* with the long edge towards the printer.

### Labels

Labels must be fed to the *MP Tray*. One label can be loaded at a time.

The basic rule for printing on adhesive labels is that the adhesive must never come into contact with any part of the machine. Adhesive paper sticking to the drum or rollers will damage the machine.

Label paper has a structure comprising of three layers, as shown in the diagram. The top sheet is printed on. The adhesive layer consists of pressure-sensitive adhesives. The carrier sheet (also called the linear or backing sheet) holds the labels until used. Due to the complexity of its composition, adhesive-backed label paper is particularly likely to give printing problems.

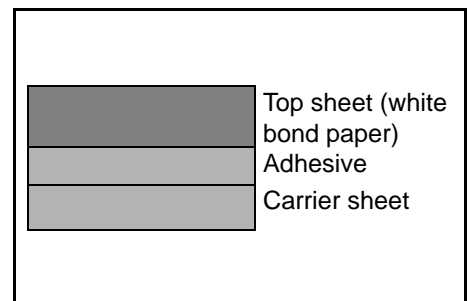

Adhesive label paper must be entirely covered by its top sheet, with no spaces between the individual labels. Labels with spaces in between are liable to peel off, causing serious paper jam problems.

Some label paper is manufactured with an extra margin of top sheet around the edge. Do not remove the extra top sheet from the carrier sheet until after printing is finished.

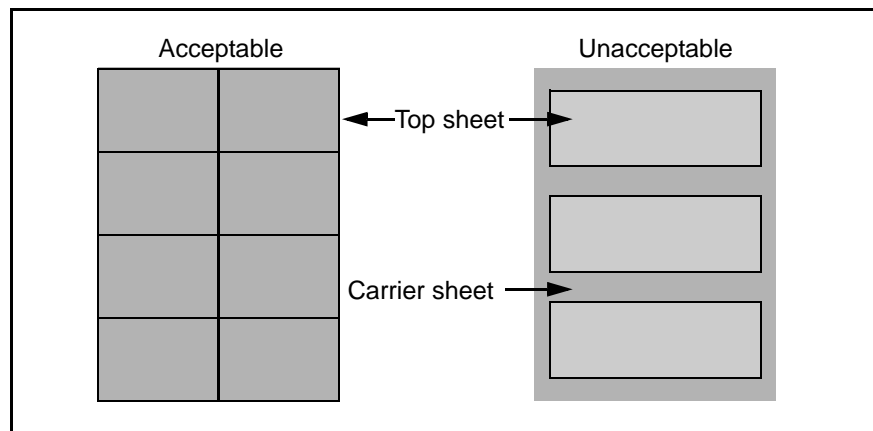

The table below lists the specifications for adhesive label paper.

Item	Specification
Weight of top sheet	44 to 74g/m <sup>2</sup> (12 to 20 lb/ream)
Composite weight	104 to 151g/m <sup>2</sup> (28 to 40 lb/ream)
Thickness of top sheet	0.086 to 0.107mm (3.9 to 4.2 mils)
Composite thickness	0.115 to 0.145mm (4.5 to 5.7 mils)
Moisture content	4 to 6% (composite)

### Postcards

Up to 10 postcards can be loaded at a time. Fan the stack of postcards and align the edges before loading them in the MP tray. Make sure the postcards you are going to set are not curled. Feeding curled postcards may cause paper jams.

Some postcards have rough edges on the back (those are created when the paper is cut). In this case, put the postcards on a flat place and rub the edges with, for example, a ruler to smooth them.

### Envelopes

Up to 5 envelopes can be loaded at a time. Envelopes should be fed in the face-up position, right edge first.

Since the composition of an envelope is more complex than that of ordinary paper, it is not always possible to ensure consistent printing quality over the entire envelope surface.

Normally, envelopes have a diagonal grain direction. Refer to *Paper Grain* on page 2-6. This direction can easily cause wrinkles and creases when envelopes pass through the printer. Before purchasing envelopes, make a test print to check whether the printer accepts the envelope.

- Do not use envelopes that have an encapsulated liquid adhesive.
- Avoid a long printing session for envelopes only. Extended envelope printing can cause premature printer wear.
- If jams occur, try setting less envelopes on the MP tray.
- To avoid jams caused by curled envelopes, stack no more than 10 printed envelopes on the output tray.

---

## Thick Paper

Fan the stack of paper and align the edges before loading them in the MP tray. Some types of paper have rough edges on the back (those are created when the paper is cut). In this case, put the paper on a flat place and rub the edges once or twice with, for example, a ruler to smooth them. Feeding rough edged paper may cause paper jams.



**Note** If the paper jams even after you smooth it out, load the paper in the MP Tray with the leading edge raised up a few millimeters as shown in the illustration.

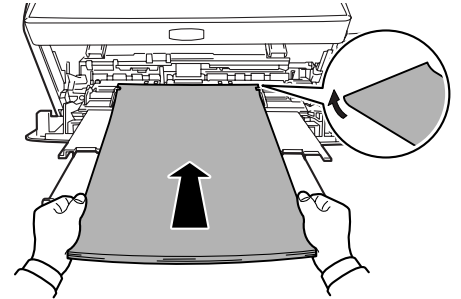

## Colored Paper

Colored paper should satisfy the same conditions as white bond paper. Refer to *Paper Specifications* on page 2-2. In addition, the pigments used in the paper must be able to withstand the heat of fusing during the printing process (up to 200°C or 392°F).

## Preprinted Paper

Preprinted paper should satisfy the same conditions as white bond paper. Refer to *Paper Specifications* on page 2-2. The preprinted ink must be able to withstand the heat of fusing during the printing process, and must not be affected by silicone oil.

Do not use paper with any kind of surface treatment, such as the type of paper commonly used for calendars.

## Recycled paper

Select recycled paper that meets the same specifications as the white bond paper except for whiteness. Refer to *Paper Specifications* on page 2-2.



**Note** Before purchasing recycled paper, test a sample on the machine and check that the printing quality is satisfactory.

## Paper Type

The printer is capable of printing under the optimum setting for the type of paper being used.

A different paper type setting can be made for each paper source including the MP tray. Not only can preset paper types be selected, but it is also possible for you to define and select customized paper types. Paper type can be changed using the printer driver and *Configuration Tool*. The following types of paper can be used.

Paper Type	Paper source				
	MP tray	Paper Cassette	Paper Weight		Duplex path (MP tray available only in Cassette mode)
			Range	Display in Status Monitor	
Plain	Yes	Yes	64 to 90g/m <sup>2</sup>	Normal2	Yes
Transparency	Yes	No	Transparency	Extra Heavy	No
Preprinted	Yes	Yes	75 to 90g/m <sup>2</sup>	Normal2	Yes
Labels	Yes	No	105 to 135g/m <sup>2</sup>	Heavy1	No
Bond	Yes	Yes	90 to 105g/m <sup>2</sup>	Normal3	Yes
Recycled	Yes	Yes	75 to 90g/m <sup>2</sup>	Normal2	Yes
Vellum	Yes	No	Less than 64g/m <sup>2</sup>	Light	No
Rough	Yes	Yes	90 to 105g/m <sup>2</sup>	Normal3	Yes
Letterhead	Yes	Yes	75 to 90g/m <sup>2</sup>	Normal3	No
Color	Yes	Yes	75 to 90g/m <sup>2</sup>	Normal3	Yes
Prepunched	Yes	Yes	75 to 90g/m <sup>2</sup>	Normal2	Yes
Envelope	Yes	No	135 to 170g/m <sup>2</sup>	Heavy3	No
Cardstock	Yes	No	135 to 170g/m <sup>2</sup>	Heavy3	No
Thick	Yes	No	135 to 170g/m <sup>2</sup>	Heavy3	No
High quality	Yes	Yes	75 to 90g/m <sup>2</sup>	Normal2	Yes
Custom 1 (to 8)*	Yes	Yes	75 to 220g/m <sup>2</sup>	Normal2	Yes

Yes: Can be stored    No: Cannot be stored

- \*. This is a paper type defined and registered by the user. Up to eight types of user settings may be defined. User can also enable or disable the duplex path when using Custom. For more information, refer to *Status Monitor* on page 3-6.



---

## Preparing the Paper

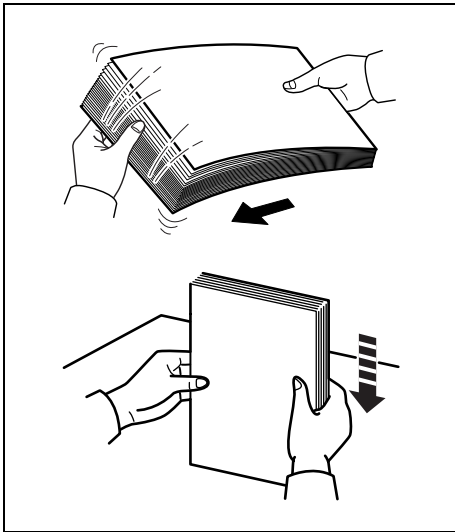

After removing paper from the packaging, fan through the sheets to separate them prior to loading.

If using paper that has been folded or is curled, straighten it prior to loading. Failure to do so may result in a paper jam.

**IMPORTANT** Ensure paper is not stapled and clips are removed.

## Loading Paper into Cassette

250 sheets of 11 × 8 1/2" or A4 paper (80 g/m<sup>2</sup>) may be loaded into the Cassette.

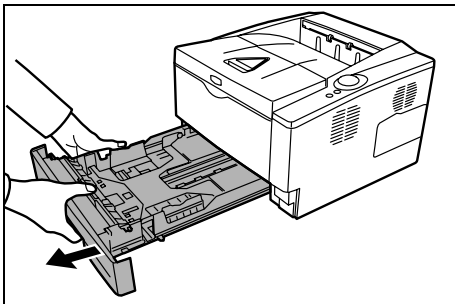

- 1 Pull the cassette completely out of the printer.

**IMPORTANT** When pulling the cassette out of the printer, ensure it is supported and does not fall out.

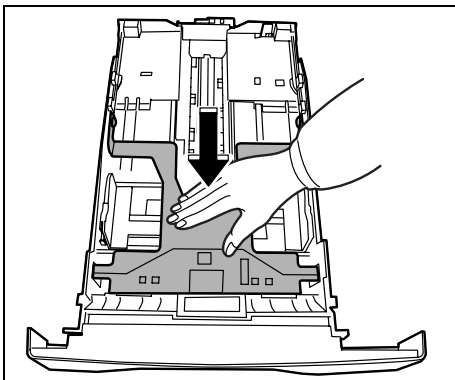

- 2 Press the bottom plate down until it locks.

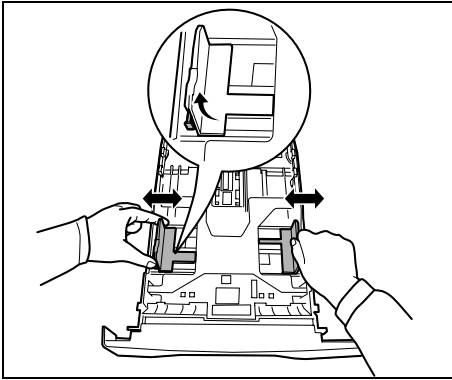

- 3 Adjust the position of the width guides located on the left and right sides of the cassette. Press the release button on the left guide and slide the guides to the paper size required.



**Note** Paper sizes are marked on the cassette.

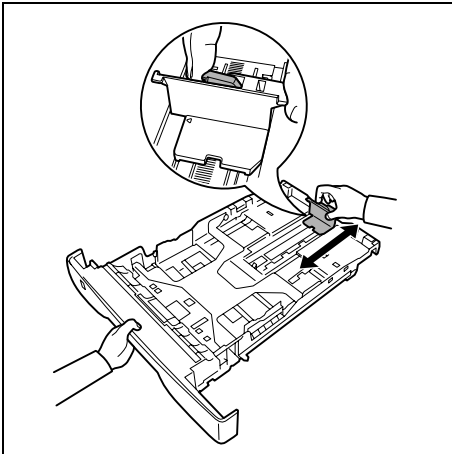

- 4 Adjust the paper length guide to the paper size required.

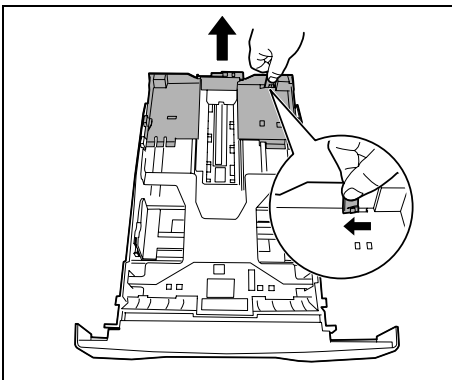

If you are going to use paper that is longer than A4, pull out the extension paper cassette by pushing the release lever one by one and adjust it to the desired paper size.

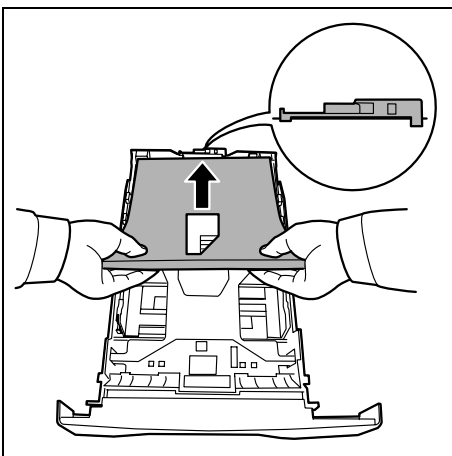

- 5 Load the paper in the cassette. Ensure the side to be printed is facing down and the paper is not folded, curled, or damaged.

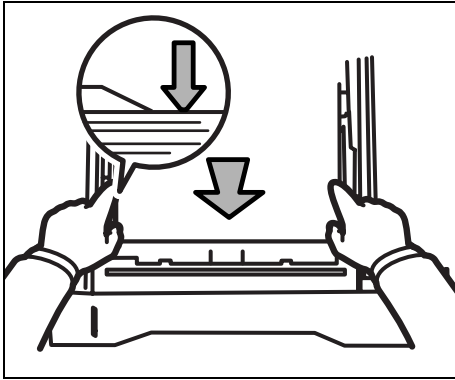

 **Note** Do not load paper above the triangle mark located on the width guide.

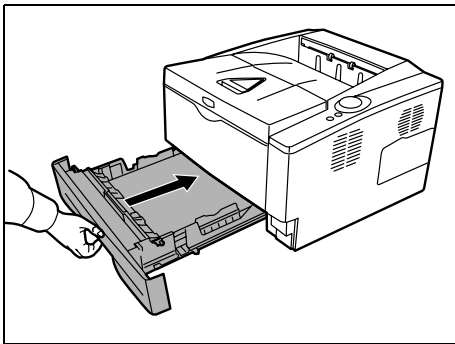

6 Insert the paper cassette into the slot in the printer. Push it straight in as far as it will go.

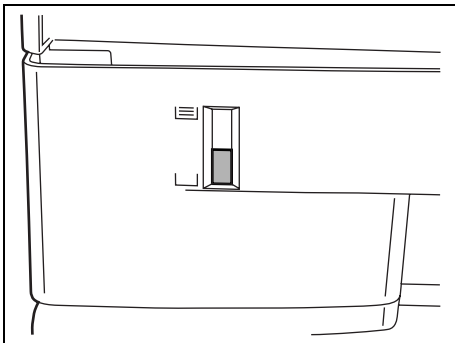

There is a paper gauge on the left side of the front of the paper cassette to indicate the remaining paper supply. When paper is exhausted, the pointer will go down to the level of (empty).

## Loading Paper into MP (Multi-Purpose)Tray

FS-1300D can load 50 sheets of 11 × 8 1/2" or A4 paper (80 g/m<sup>2</sup>) into the MP Tray. On the other hand, FS-1100 can one sheet into the MP Tray.

- 1 Pull the MP tray towards you until it stops..

**IMPORTANT** When pulling the cassette out of the printer, ensure it is supported and does not fall out.

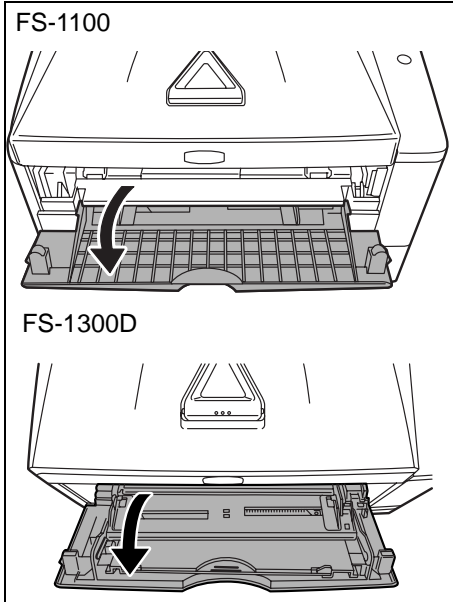

- 2 Adjust the position of the paper guides on the MP tray. Standard paper sizes are marked on the MP tray. For standard paper sizes, slide the paper guides to the corresponding mark.

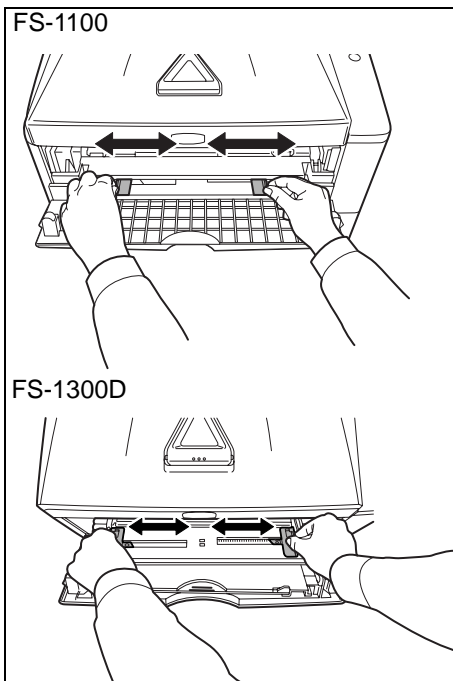

- 3 Pull out the subtray (for FS-1300D).

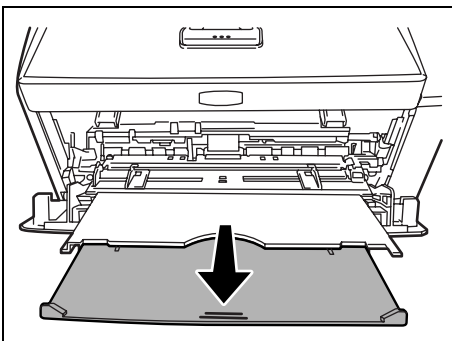

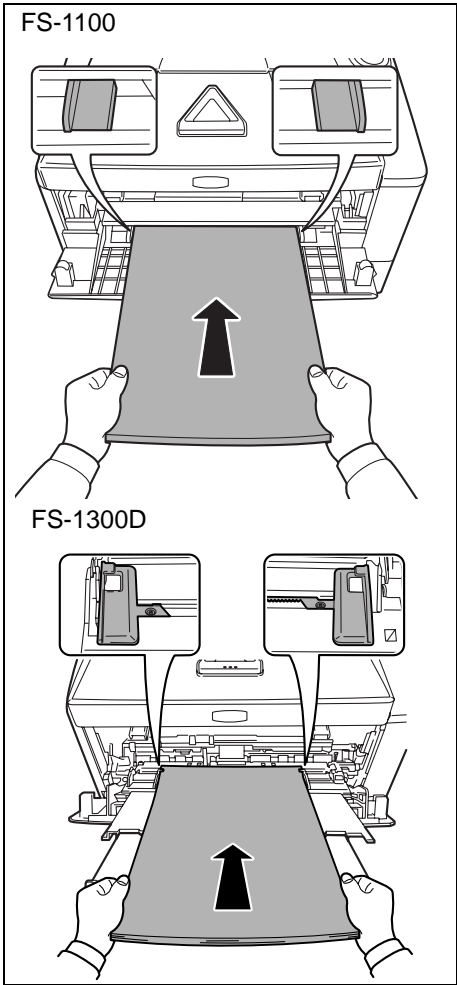

4 Align the paper with the paper guides and insert as far as it will go.



**Note** Do not load more paper than exceeds the tab of the MP tray (only for FS-1300D).



**Note** If the paper is considerably curled in one direction, for example, if the paper is already printed on one side, try to roll the paper in the opposite direction to counteract the curl. Printed sheets will then come out flat (For FS-1300D only).

Correct		
Incorrect		

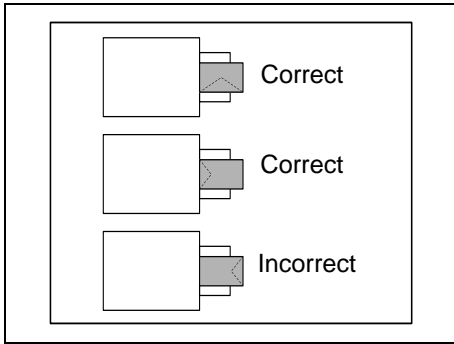

When loading envelope, place with the envelope flap closed and keep the printing side face-up. Insert envelope against the guide with the flap on the front or left side until they stop.

- 5 Specify the paper size and type for MP tray using *Configuration Tool*. For more information, refer to *Configuration Tool* on page 3-9.

---

## 3 Connecting and Printing

---

This chapter explains the following operations.

<b>Connections</b>	<b>3-2</b>
<b>Loading Software</b>	<b>3-3</b>
<b>Printing</b>	<b>3-3</b>
<b>Status Monitor</b>	<b>3-6</b>
<b>Configuration Tool</b>	<b>3-9</b>
<b>Uninstalling Software</b>	<b>3-13</b>

---

## Connections

This section explains how to start up the printer.

### Connecting the USB Cable

Follow the steps as below for connecting the USB cable.

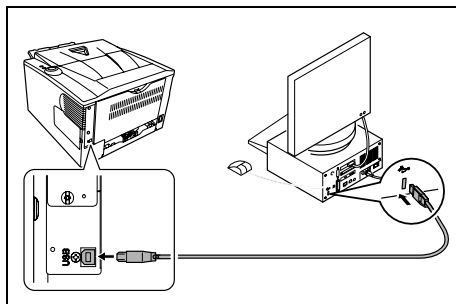

- 1 Connect the USB cable (not included) to the USB Interface Connector.



**Note** Use a USB cable with a rectangular Type A plug and a square Type B plug. The USB cable should be shielded and no longer than 5 meters (16 feet) long.

- 2 Connect the other end of the USB cable to the computer's USB interface connector.

### Connecting the Power Cord

Install the printer close to an AC wall outlet. If an extension cord is used, the total length of the power cord plus extension should be 5 meters (16 feet) or less.



**Note** Ensure the printer's power switch is off. Only use the power cord supplied with the printer.

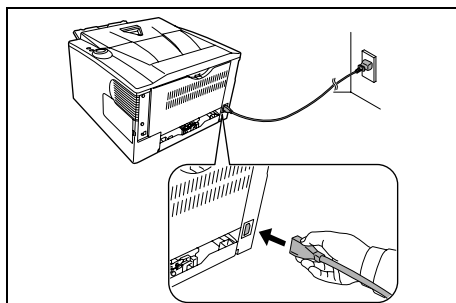

- 1 Connect the power cord to the Power Cord Connector at the rear of the printer.

- 2 Connect the other end of the power cord to a power outlet.

- 3 Press the Power Switch to On ( | ). The printer begins to warm up.

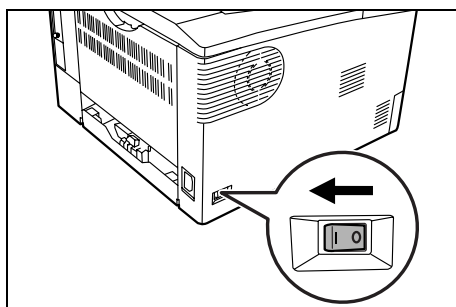

**IMPORTANT** If you install the toner container and switch on the power, after a moment the indicators light in anticlockwise direction. When the printer is first switched on after toner installation, there will be a delay of approximately 15 minutes before the printer gets ready to print. Once the (Ready) indicator lights, printer installation is complete.



---

## Loading Software

Ensure the printer is plugged in and connected to the computer's parallel or USB port before installing software from the CD-ROM.

- 1 Switch on the PC and activate Windows.

 **Note** If the Welcome to the Found New Hardware Wizard dialog box displays, select Cancel.

- 2 Insert the CD-ROM (Software Library) into the CD-ROM drive.
- 3 The installation program launches and the License Agreement displays.

Select View License Agreement to read the information and select Accept to proceed.

 **Note** If the installation program fails to launch, use Windows Explorer to access the CD-ROM and select Setup.exe.

- 4 Select Install KX Driver and follow the on-screen instructions to complete the software installation.
- 5 Once the installation is complete, the Printer Installed Successfully dialog box displays.

## Printing

This section explains the printing procedure from an application software. You can specify the printing settings from each tab on KX Driver. KX Driver is stored in the CD-ROM (Product Library). For more information, refer to the KX Driver User Guide.

### About KX Driver

KX Driver consists of the following tabs.

#### Basic

Use this tab to select the page size and orientation. The paper source is also selected.

#### Layout

Use to select duplex or to create multiple pages on a single sheet of paper. Also contains the scaling option.

#### Imaging

Select this tab to change the print quality, and the font or graphic settings.

#### Publishing

Use to add covers or page inserts to your output. You can also produce a set of transparencies with a blank or printed sheet interleaved using Transparency Interleaving.

#### Advanced

Use to set up and add watermarks to your output. This tab incorporates the PRESCRIBE commands into the document.

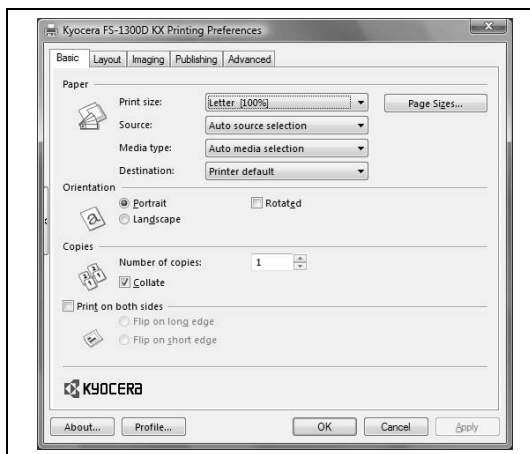

## Printing from Application Software

The steps required to print a document created with an application are explained below. You can select the printing paper size.

 **Note** You can also select the various settings by clicking Properties to open the Properties dialog box.

- 1 Load the paper required into the paper cassette.
- 2 From the application File menu, select Print. The Print dialog box appears.
- 3 Click the drop-down list of printer names. All the installed printers are listed. Click the name of the printer.
- 4 Use Number of copies to enter the number of copies required. Up to 999 copies can be printed. For Microsoft Word, we recommend that you click Options and specify Use printer settings for the Default tray.
- 5 To start printing, click OK.

## Manual Duplex (For FS-1100 only)

Use *Manual Duplex* if you require printing on both sides of the paper. The even pages are printed first and then reloaded to print the odd pages. An instruction sheet is available to assist with loading the sheets in the correct orientation and order.

 **Note** Ensure Print Instructions is selected to receive the instruction sheet. Continue to use the sheet until you are familiar with this feature.

- 1 Ensure Cassette 1 is selected as the Source in the Print Properties dialog box.



- 2 Select Print on Both Sides (Manual Duplex).

Select Gutter Settings on Layout tab and enter the value required for each edge. Gutter width range is 5.00 to 25.4mm (0.20 to 1.00 inch). Select Reduce Image to fit as required.

Select Print on both side (manual duplex), and use the Duplex Details option to select *Flip on Long Edge* for binding on the long edge or *Flip on Short Edge* for binding on the short edge. Select Print manual duplex instructions to receive the reloading instructions.

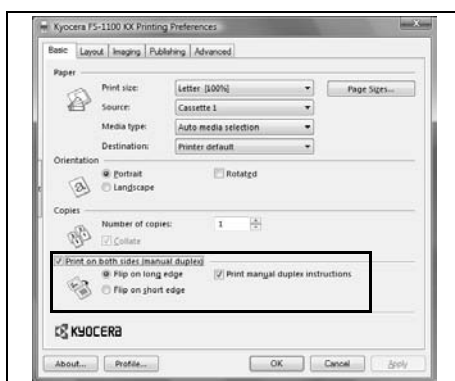

- 3 Select OK to return to the Print dialog box and select OK to start printing. A Manual Duplex instruction message box displays. The even pages are printed including the instruction sheet.



**Note** Nothing will be printed on the instruction sheet.

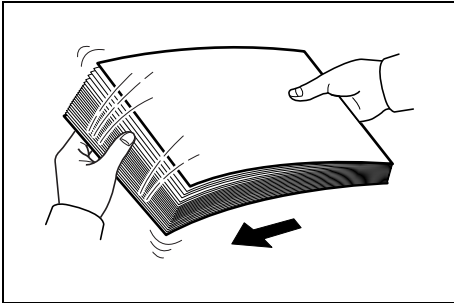

- 4 Remove all the even pages (including the instruction sheet) from the output tray, fan through the sheets to separate them prior to loading.

- 5 Load the even pages printed into the paper cassette with the instruction sheet facing up and the arrows pointing toward the printer.

Long Edge Binding

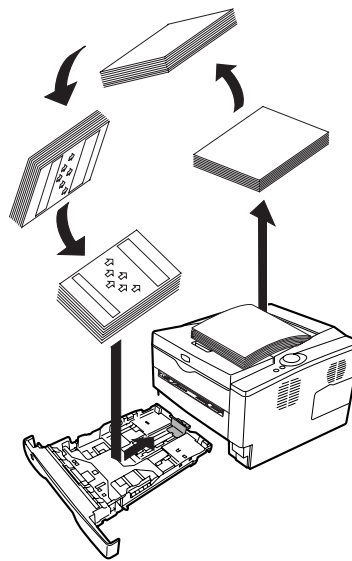

Short Edge Binding

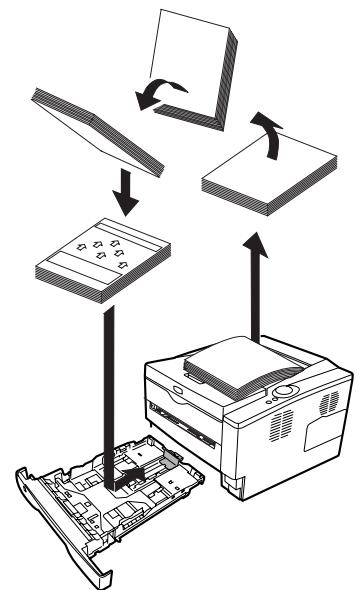

**Note** If the paper is considerably curled in one direction, roll the paper in the opposite direction to counteract the curl. If this will not cancel the curl satisfactorily, try to reduce the number of sheets loaded in the paper cassette to the maximum of 100.

- 6 Select OK on the Manual Duplex instruction message box. All the odd pages will be printed.

---

## Status Monitor

The Status Monitor monitors the printer status and provides an ongoing reporting function. It also allows you to specify and modify settings for printers not included in the KX driver.

The Status Monitor is installed automatically during KX driver installation.

## Accessing the Status Monitor

Use either of the methods listed below to launch the Status Monitor.

- **Launch when printing starts:**  
When you specify a printer and start a print job, one Status Monitor is launched for each printer name. If Status Monitor startup is requested from multiple printers, Status Monitors are launched for each printer that issues the request.
- **Launch from the KX driver properties:**  
Right-click the Version Info button in the KX driver Properties dialog box. Then click the Status Monitor button in the Version Info dialog box to launch the Status Monitor.

## Exiting the Status Monitor

Use either of the methods listed below to exit the Status Monitor.

- **Exit manually:**  
Click the printer icon in the taskbar and select "Exit" in the menu to exit the Status Monitor.
- **Exit automatically:**  
The Status Monitor automatically shuts down after 30 minutes if it is not being used.

## Screen Overview

The screen overview of the Status Monitor is as follows.

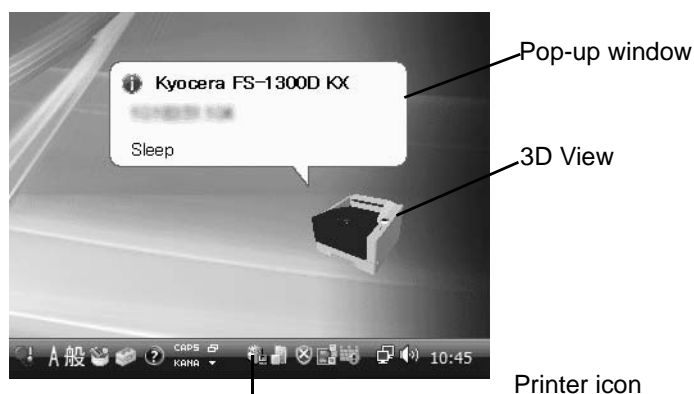

### Pop-up window

If an information notification event occurs, a pop-up window appears. This window only appears when the 3D View is open on the desktop.

### 3D View

This shows the status of the monitored printer as a 3D image. You can choose whether to show or hide the 3D view from the menu displayed when you right-click the printer icon.

---

If an information notification event occurs, the 3D view and an alert sound are used to notify you. For information on the sound notification settings, refer to *Status Monitor Settings* on page 3-8.

**Printer icon**

The printer icon is displayed in the taskbar notification area when the Status Monitor is running. When you position the cursor over the icon, the printer name appears.

---

## Status Monitor Settings

The Status Monitor has two tabs to configure its settings. Use the Preference option to set up the Status Monitor.

### Sound Notification Tab

The Event Notification tab contains the following items.

#### Enable Event Notification

Select to enable or disable monitoring the events in Available events.

#### Sound file

A sound file can be selected if you require an audible notification. Click Browse to search for the sound file.

#### Use Text to speech

Select this check box to enter text you would like to hear played for events. Although a sound file is unnecessary, this function is applicable for Windows XP.

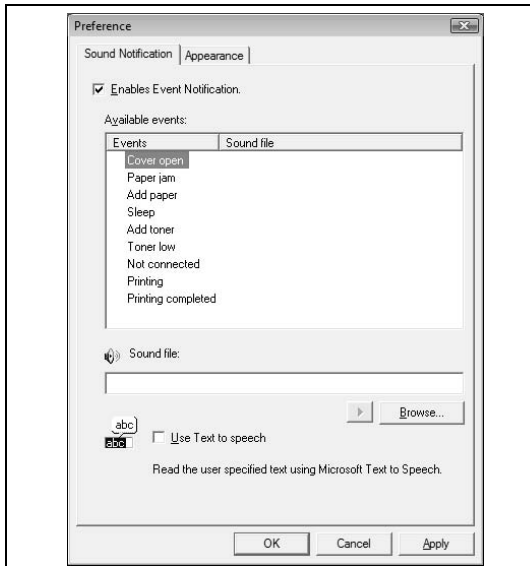

To use this function, follow these steps.

- 1 Select an event to use with the text to speech function in Available events.
- 2 Select Use Text to speech.
- 3 Enter the text to be played in the Text to speech box.
- 4 Click Play to confirm the text is spoken correctly.

### Appearance Tab

The Appearance tab is contains the following items.

#### Enlarge window

Doubles the size of the Status Monitor window.

#### Always on top

Positions the Status Monitor in front of other active windows.

#### Transparency

Displays the Status Monitor as a transparent window.

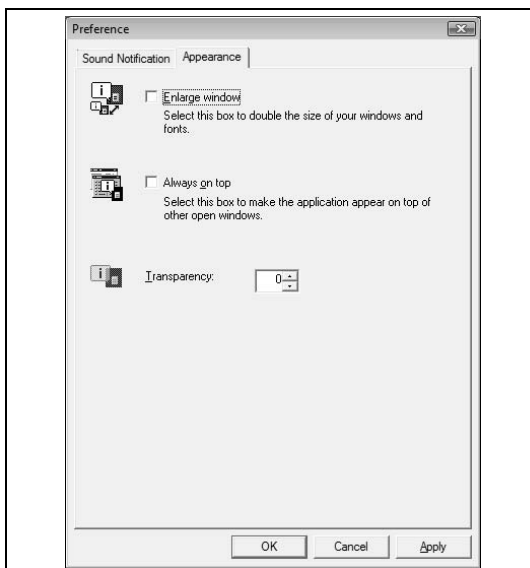

---

## Configuration Tool

The Configuration Tool is a Status Monitor function that allows you to check and/or change the settings for printers not included in the KX driver.

When you install the KX driver, you can choose to install the Configuration Tool as an optional function.

The Configuration Tool can be used for printers connected to the PC via a USB cable. If a printer is connected via a network cable, the COMMAND CENTER starts up.

For details about the Configuration Tool, refer to its help file.



**Note** The contents of the Properties dialog box will vary depending on the installed optional devices, and whether the device is connected by a network interface or a local interface.

## Accessing the Configuration Tool

Follow these steps to display the Configuration Tool on the desktop.

- 1 Right-click the printer icon in the Windows taskbar.
- 2 Select "Configure the Printing System" from the menu. The Configuration Tool window appears.

## Exiting the Configuration Tool

Use either of the methods listed below to exit the Configuration Tool.

- Exit using the Close button:  
Click the Close button in the top-right corner of the Configuration Tool window.
- Exit using the [OK] or [Cancel] button:  
Clicking [OK] exits the Configuration Tool after applying the modified printer settings. Clicking [Cancel] exits the Configuration Tool without applying the modified printer settings.

## Status Tab

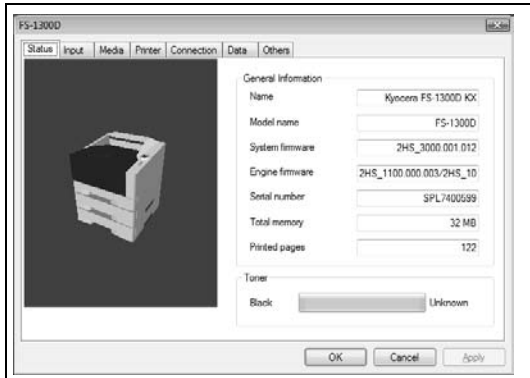

The Status tab displays current information about the device, such as the model name, system firmware, engine firmware, serial number, and number of printed pages.

## Input Tab

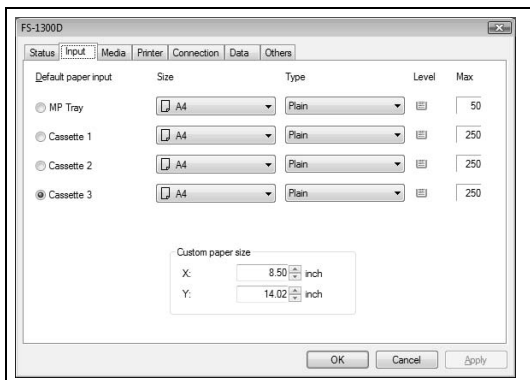

The Input tab displays information about the paper feeder attached to the machine, such as the current paper level and the maximum paper capacity.

This tab also enables you to customize the paper size and type of the paper supply. If you selected Custom as the paper size for the MP Tray in the KX driver, you can use this tab to set the width and height of the custom paper.

## Media Tab

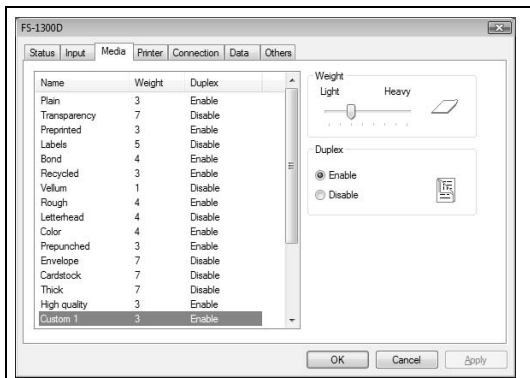

The Media tab displays and lets you select the weight for each media type. It also displays whether each media type is available for duplex printing.



---

## Printer Tab

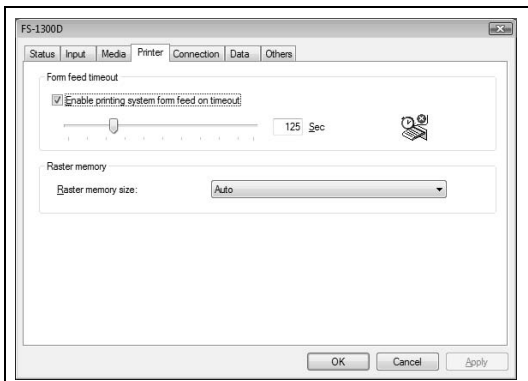

The Printer tab allows you to set print processing parameters that are not available in the KX driver. As well as the printing density and form feed timeout, you can change the memory size used for processing raster data such as bitmap and JPEG files.

## Connection Tab

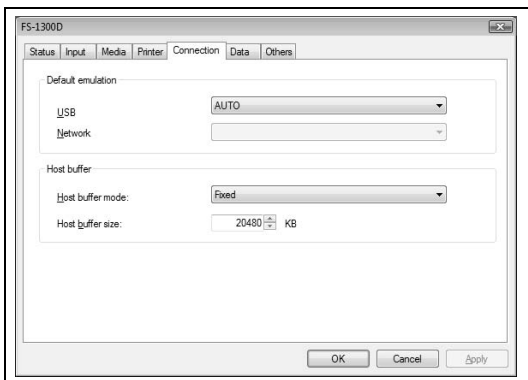

You can use the Connection tab to set the emulation. You can also use this tab to change the buffer memory size and buffer mode used on the host for communication processing.

## Data Tab

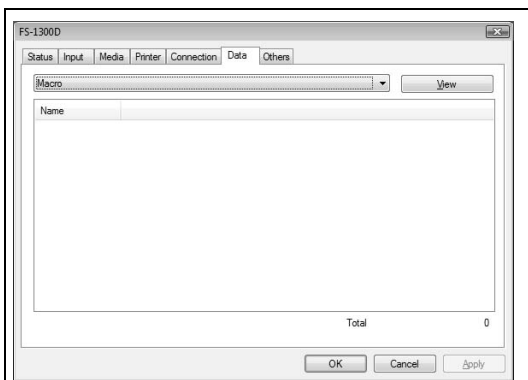

The Data tab fetches and lists the data used in other communication processes, such as PRESCRIBE. Select a data type and click [View] to fetch and display a list of the target data from the printer. The information displayed includes the name, type and storage location.

## Others Tab

The Others tab enables you to configure the printer settings shown below.

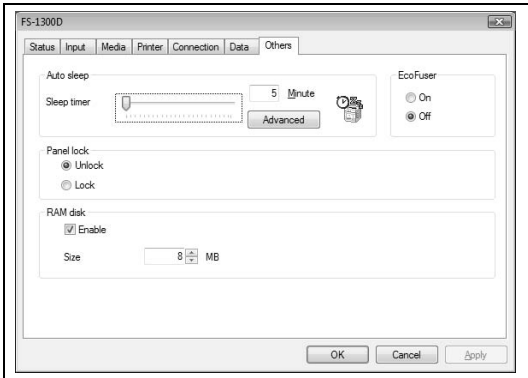

Item	Description
Auto sleep	Configures the amount of time when the printer automatically enters Sleep Mode. Click [Advanced] to turn Auto sleep on or off.
EcoFuser	Enables or disables the EcoFuser. Select On to reduce the power consumption to a minimum by turning off the heater of the fixing unit at Sleep Mode. The default setting is On.
Panel lock	Locks or unlocks the operation panel. Locking the operation panel disables key operations from the panel.
RAM disk	Enables or disables RAM disk mode. Enabling the RAM disk allows you to use it as a temporary storage area for data such as font files or the contents of the receive buffer. You can also specify the RAM disk format by clicking [Advanced] when the RAM disk is enabled.

---

## Uninstalling Software

The CD-ROM lets you remove the printer software.

- 1 Click Remove Software. The Uninstall Wizard appears.
- 2 Select the software package to remove.
- 3 Click Uninstall. Removal of the printer software starts.
- 4 When removal is complete, click Finish.



---

## 4 Maintenance

---

This chapter contains explanations on the following topics:

<b>General Information</b>	<b>4-2</b>
<b>Toner Container Replacement</b>	<b>4-2</b>
<b>Cleaning the Printer</b>	<b>4-6</b>
<b>Prolonged Non-Use and Moving the Printer</b>	<b>4-9</b>

---

## General Information

This chapter describes basic maintenance tasks you can perform for the printer. You can replace the toner container according to the printer's status:

Also, the internal parts need periodic cleaning.



**Note** Information Collection on Memory Chips - The memory chip attached to the toner container is designed to improve convenience for the end user; to support the recycling operation of empty toner containers; and to gather information to support new product planning and development. The information gathered is anonymous - it cannot be associated to any specific individual and the data is intended to be used anonymously.

## Toner Container Replacement

The Toner indicator identifies the toner status at two stages of toner usage.

- When the printer becomes low on toner, the toner indicator for the individual colors flashes. Note the replacement is not always necessary at this stage.
- If you ignore the above status and continue printing, the Toner indicator lights up just before the toner is used up. The toner container must then be replaced immediately.

In either case, replace the toner container.

## Frequency of toner container replacement

Assuming an average toner coverage of 5% and EcoPrint mode turned off, the toner container will need replacing approximately once every 7,200 pages.

### Starter Toner Container

The toner container packed with the new printer is a starter toner container. The starter toner container lasts an average of 3,600 pages.

### Toner Kits

For best results, we recommend that you only use genuine Kyocera Parts and Supplies.

A new toner kit contains the following items:

- Toner Container
- Plastic waste bag for old toner container
- Installation Guide



**Note** Do not remove the toner container from the carton until you are ready to install it in the printer.

---

## Replacing the Toner Container

This section explains how to replace the toner container.



**CAUTION** Do not attempt to incinerate the Toner Container. Dangerous sparks may cause burns.

**IMPORTANT** During toner container replacement, temporarily move storage media and computer supplies (such as floppy disks) away from the toner container. This is to avoid damaging media by the magnetism of toner.

**IMPORTANT** Kyocera Mita Corporation is not liable against any damages or problems arising from the use of toner containers other than those designated as original Kyocera toner containers. For optimum performance, it is also recommended to use only the Kyocera toner containers which are specifically intended for use in your country or region.



**Note** You do not have to turn printer power off before starting the replacement. Any data that may be processing in the printer will be deleted if you turn the printer power off.

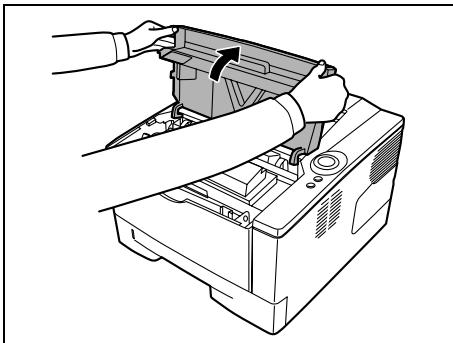

- 1 Open the top cover.

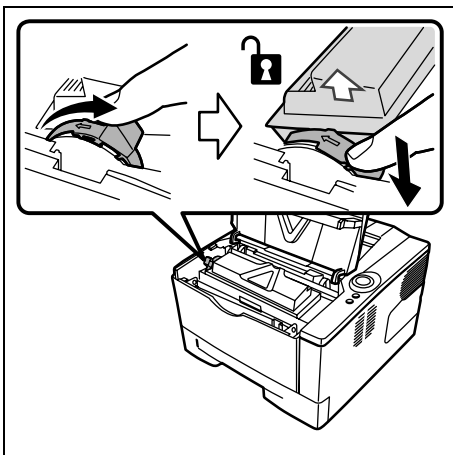

- 2 Turn lock lever to the unlock position. Push lock lever to the position marked arrow and pull out the toner container.



**Note** Put the old toner container in the plastic bag (supplied with the new toner kit) and discard it later according to the local code or regulations for waste disposal.

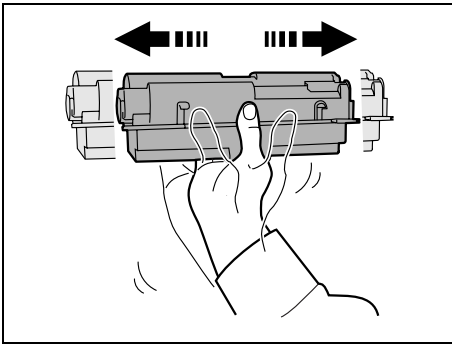

- 3 Take the new toner container out of the toner kit. Shake the new toner container at least 5 times as shown in the figure in order to distribute the toner evenly inside the container.

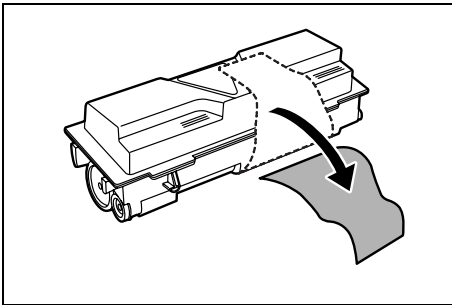

- 4 Remove the label from the toner container.

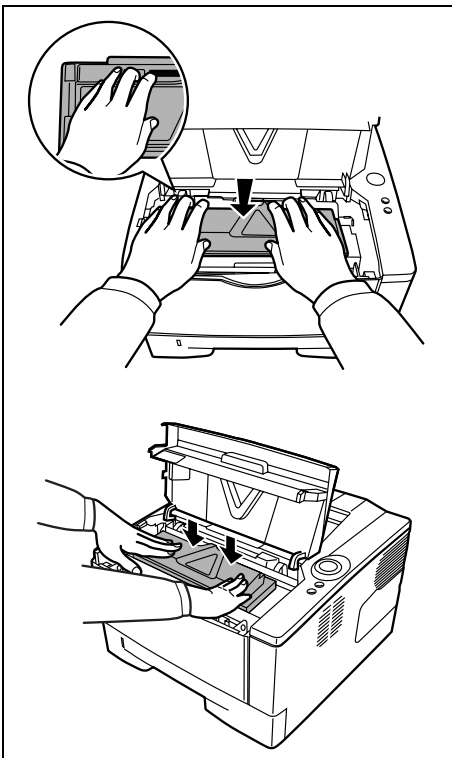

- 5 Install the new toner container in the printer. Push firmly on the top of the container at the positions marked PUSH HERE, until you hear a click.



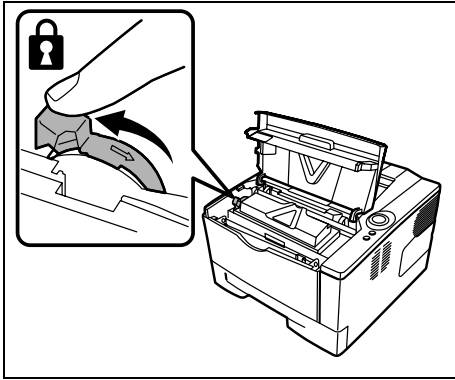

- 6 Turn lock lever to the lock position.
- 7 Close the top cover.

---

## Cleaning the Printer

To avoid print quality problems, the interior of the printer must be cleaned with every toner container replacement.

- 1 Open the top cover and front cover.

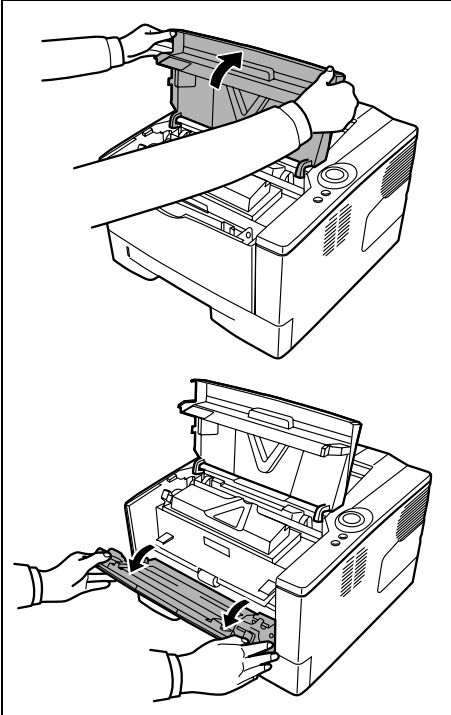

- 2 Lift the process unit together with the toner container out of the printer.

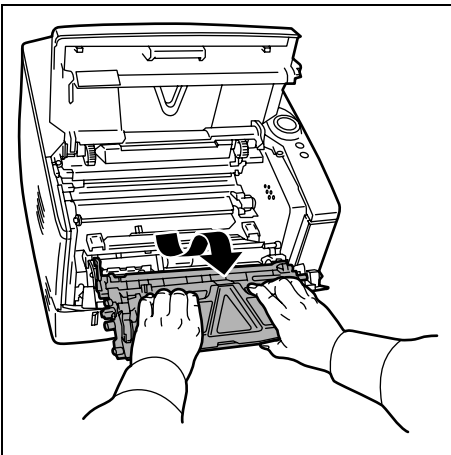

- 3 Remove the drum unit from the printer by holding the green levers with both hands.



**Note** The drum is sensitive to light. Never expose the process unit to light for more than five minutes.

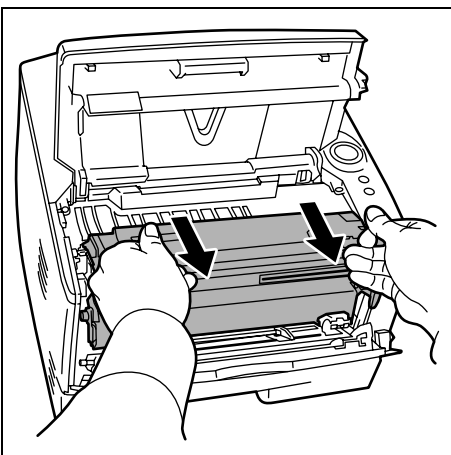

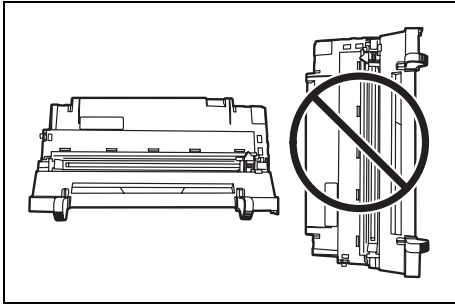

- 4 Place the drum unit flat on a clean, level surface.  
**IMPORTANT** Do not place the drum unit on end.

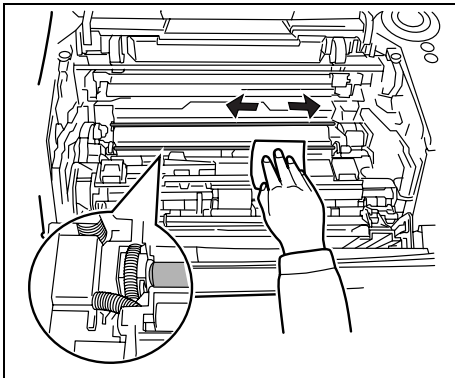

- 5 Use a clean, lint free cloth to clean dust and dirt away from the metal registration roller.  
**IMPORTANT** Take care not to touch the transfer roller (black) during cleaning.

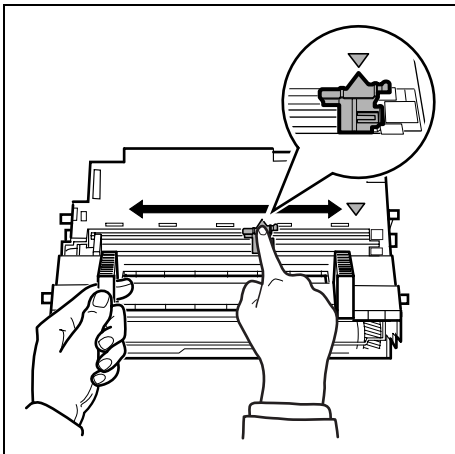

- 6 Slide the charger cleaner (green) back and forth 2 or 3 times to clean the charger wire, then return it to its original position (CLEANER HOME POSITION ).  
**IMPORTANT** After cleaning, make sure you restore the charger cleaner to its home position.

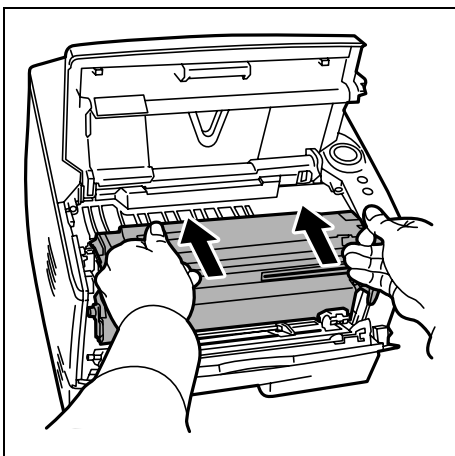

- 7 When cleaning is complete, return the drum unit to the original position.

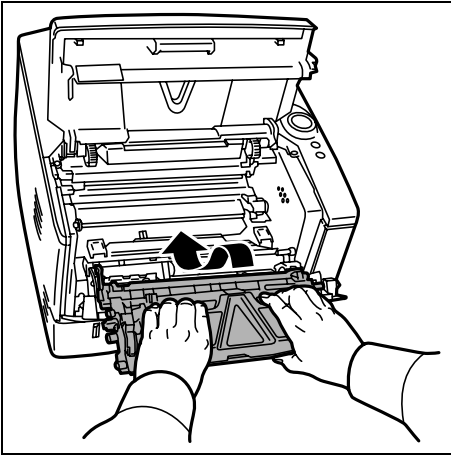

- 8 Return the process unit to its position, aligning the guides at both ends with the slots in the printer. Then, close the front cover and top cover.

---

## Prolonged Non-Use and Moving the Printer

### Prolonged Non-use

If you ever leave the printer unused for a long period of time, remove the power cord from the wall outlet.

We recommend you consult with your dealer about the additional actions you should take to avoid possible damage that may occur when the printer is used next time.

### Moving the Printer

When you move the printer:

- Move it gently.
- Keep it as level as possible to avoid spilling toner inside the printer.
- Be sure to consult a service technician before attempting long distance transportation of the printer.



**WARNING** If you ship the printer, remove and pack the process unit and drum unit in a plastic bag and ship them separately from the printer.



---

# 5 Troubleshooting

---

This chapter describes cleaning and toner replacement.

<b>General Guidelines</b>	<b>5-2</b>
<b>Print Quality Problems</b>	<b>5-3</b>
<b>Understanding Indicators</b>	<b>5-6</b>
<b>Cleaning Paper Jams</b>	<b>5-10</b>

## General Guidelines

The table below provides basic solutions for problems you may encounter with the printer. We suggest you consult this table to troubleshoot the problems before calling for service repairs.

Symptom	Check Items	Corrective Actions
The printer will not print from the computer.	Check the Ready indicator.	Using the information on page 1-5, check if an error has occurred and clear the error.
	Check if a status page can be printed.	If the status page was printed successfully, there may be a problem with the connection to the computer. Refer to the Installation Guide and check the connection.
	Check that the indicators display in a recognized combination. Refer to <i>Indicators</i> on page 1-5 for further information.	Turn the power switch Off (O) and then On ( ) again. Print the job again.
Print quality is poor.		Refer to <i>Print Quality Problems</i> on page 5-3.
Paper is jammed.		Refer to <i>Cleaning Paper Jams</i> on page 5-10.
The indicators are off and the fan is not working.	Check the power cord.	Connect both ends of the power cord securely. Try replacing the power cord. Refer to Installation Guide for information.
	Check the power switch is in the On ( ) position.	Refer to the <i>Installation Guide</i> for more information.
The printer prints a status page but data from the computer is not being printed.	Check program files and application software.	Try printing another file or using another print command. If the problem occurs with a specific file or application, check the printer settings for that application.
	Check the interface cable.	Connect both ends of the interface cable securely. Try replacing the printer cable. Refer to the Installation Guide for more information.

### Tips

Printer problems may be solved easily by following the tips below. When you have encountered a problem that cannot be solved following the guidelines above, try the following:

- Restart the computer you are using to send print jobs to the printer.
- Obtain and use the latest version of the printer driver. The latest versions of printer drivers and utilities are available at: <http://www.kyoceramita.com/download/>.
- Make sure that the procedures for printing are correctly followed in the application software. Consult the documentation supplied with the application software.





## Print Quality Problems

The tables and diagrams in the following sections define print quality problems and the corrective action you can conduct to solve the problems. Some solutions may require cleaning or replacing parts of the printer.

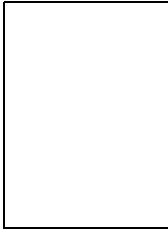
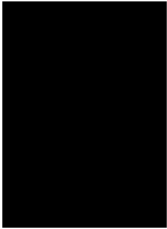
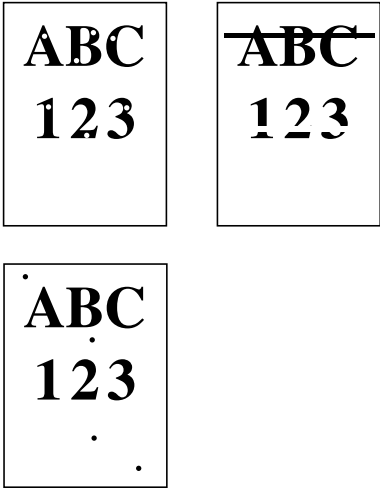
If the suggested corrective action will not solve the problem, call for service.

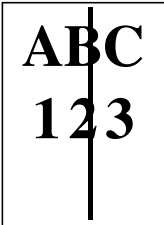
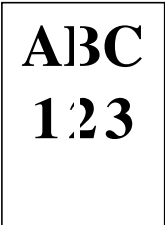
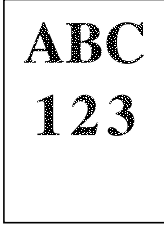
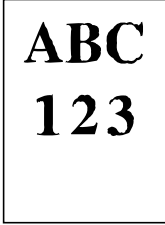
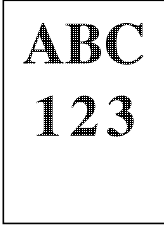
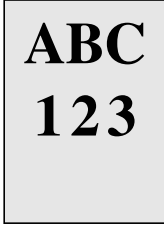
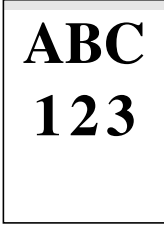
Printed Results	Corrective Action
<p><b>Completely blank printoutt</b></p> 	<p>Check the toner container. Open the front cover and check that the toner container is correctly installed in the printer. Refer to <i>Toner Container Replacement</i> on page 4-2.</p>
<p><b>Full single-color printout</b></p> 	<p>Contact your service technician.</p>
<p><b>Dropouts, horizontal streaks, stray dots</b></p> 	<p>Clean the charger wire, refer to <i>Cleaning the Printer</i> on page 4-6.</p>

Printed Results	Corrective Action
<p data-bbox="148 297 339 327"><b>Vertical streaks</b></p> <div data-bbox="169 360 333 584">  </div> <div data-bbox="384 360 549 584">  </div>	<p data-bbox="643 297 1398 360">Check the toner container and if necessary replace. Refer to <i>Toner Container Replacement</i> on page 4-2.</p> <p data-bbox="643 383 1425 412">Clean the charger wire. Refer to <i>Cleaning the Printer</i> on page 4-6.</p> <p data-bbox="643 434 1350 497">Check the charger cleaner is in its original position. Refer to <i>Cleaning the Printer</i> on page 4-6.</p>
<p data-bbox="148 633 440 663"><b>Faint or blurred printing</b></p> <div data-bbox="172 696 336 920">  </div> <div data-bbox="384 696 549 920">  </div> <div data-bbox="172 954 336 1178">  </div>	<p data-bbox="643 633 1398 696">Check the toner container and if necessary replace. Refer to <i>Toner Container Replacement</i> on page 4-2.</p> <p data-bbox="643 719 1386 748">Clean the charger wire. Refer to <i>Cleaning the Printer</i> on page 4-6.</p>
<p data-bbox="148 1216 360 1245"><b>Gray background</b></p> <div data-bbox="169 1267 333 1491">  </div>	<p data-bbox="643 1216 1398 1279">Check the toner container and if necessary replace. Refer to <i>Toner Container Replacement</i> on page 4-2.</p> <p data-bbox="643 1301 1418 1364">Check the process unit and drum unit are installed correctly. Refer to <i>Cleaning the Printer</i> on page 4-6.</p>
<p data-bbox="148 1529 568 1592"><b>Dirt on the top edge or back of the paper</b></p> <div data-bbox="169 1626 333 1850">  </div> <div data-bbox="384 1626 549 1850">  </div>	<p data-bbox="643 1529 1345 1592">Clean the registration roller. Refer to <i>Cleaning the Printer</i> on page 4-6.</p>

---

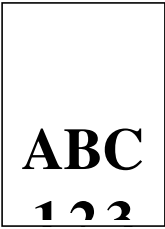
Printed Results	Corrective Action
<p data-bbox="225 297 687 331"><b>Printing incomplete or out of position</b></p> 	<p data-bbox="715 297 1513 365">Check that the printing settings are correct in the application software and the printer driver.</p> <hr/> <p data-bbox="715 383 1437 506">Check whether the problem is being caused by a PRESCRIBE command error. If the problem occurs only with a specific file or program, the most likely cause is an error in a parameter to a command or command syntax.</p>

## Understanding Indicators

The indicator displays generally fall into one of three categories: normal operation, maintenance and errors (repairs).



Click the icon  to play the animation of the indicator combinations. Right-click an indicator, then select Playback and Play to play the animation repeatedly.

**IMPORTANT** To play the animation, you have to install Adobe Flash Player and Adobe Reader (Version 6.01 or more) to your PC. If the animation is not displayed, you should get the latest version from Adobe site (<http://www.adobe.com/downloads/>).

### Normal Indication

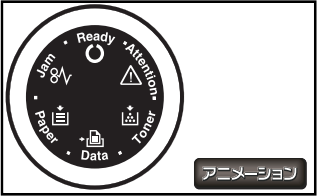
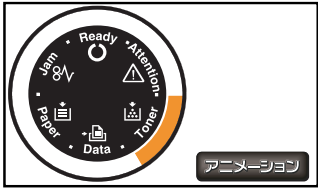
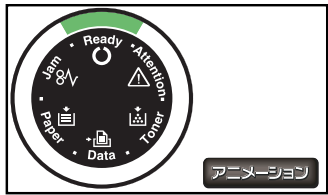
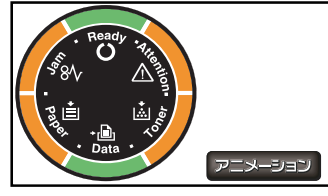

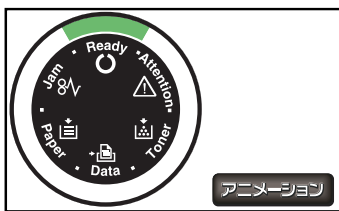

The table below shows the indicator combinations when the printer status is normal.

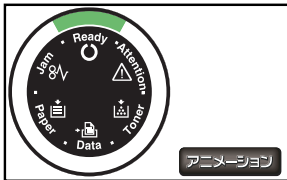

Indicator	Meaning
	The printer is canceling data.
	The printer is warning up. The printer is adjusting the color.
	The printer is having toner replaced.
	The printer is receiving data.

Indicator	Meaning
	<p>The printer is receiving data. Printing resumes when the [GO] is pressed. The printer is printing the last page after waiting.</p>
	<p>Printing is possible.</p>
	<p>Offline status. You cannot print, but the printer can receive data. The printer is in sleep mode. Printing resumes when the [GO] is pressed.</p>

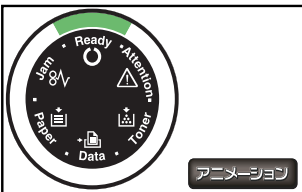
## Maintenance Indication

The table below shows the indicator combinations when user intervention is required. It is assumed that the printer is online and is processing data.

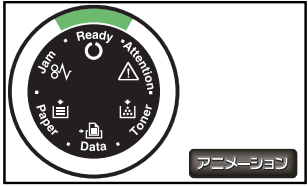
Indicator	Meaning	Remedy
	There is no paper in the cassette or MP tray. The empty paper source and required paper size are shown in <i>Status Monitor</i> and <i>COMMAND CENTER</i> .	Load paper into the paper source.
	The cassette is not inserted properly.	Insert the cassette fully into the printer.
	The front cover is open.	Close the cover.
	There is no cassette in the paper feeder or the cassette is not inserted properly.	Re-insert the cassette and then try printing again.
	The cassette does not contain the paper specified by the printer driver.	Load the size and type of paper shown in <i>Status Monitor</i> and <i>COMMAND CENTER</i> into the cassette (#[1 or 2]) and then restart printing. You can change the paper source by pressing the <b>[GO]</b> .
	The paper sizes do not match.	If the paper size in the paper source differs from the paper size and type specified by the printer driver, you can print by supplying paper from the MP tray. Load the correct paper size and type into the MP tray and press <b>[GO]</b> to begin printing.
		If you want to supply paper from a source other than the MP tray, you can change the paper source by pressing <b>[GO]</b> .
	A paper jam occurred during printing.	Open the printer cover and remove the jammed paper.

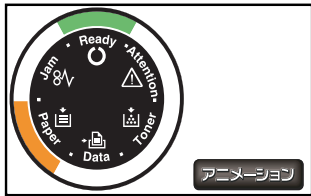
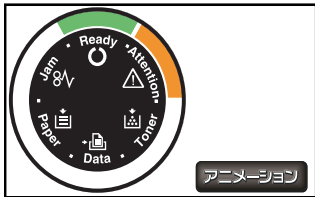
Indicator	Meaning	Remedy
	The toner is running low.	Have a new toner container ready.
	The toner has run out.	Replace with a new toner container. After replacing the toner container, clean the inside of the printer.
	Unable to print with the specified resolution due to insufficient memory.	Add the expansion memory to the printer.
	CF card is not formatted.	Format the CF card.
	Specified file not found.	Press <b>[GO]</b> to continue processing. Press <b>[Cancel]</b> to cancel processing.
	The current printing cannot be continued.	Press <b>[GO]</b> to continue processing. Press <b>[Cancel]</b> to cancel processing.
	Unable to print due to insufficient memory.	Install the optional extended memory in the printer. Press <b>[GO]</b> to continue processing. Press <b>[Cancel]</b> to cancel processing.
	Unable to print as the data is too complicated.	Press <b>[GO]</b> to continue processing. Press <b>[Cancel]</b> to cancel processing.

### Error Indication

If the indicators light or flash repeatedly in manners not described above for normal or maintenance indication, a service error has probably occurred. Turn the printer off by the power switch, wait 5 seconds and then turn the printer on again. This may clear the error. Even if the error is not cleared, contact your service technician.

## Cleaning Paper Jams

If paper jams in the paper transport system, or no paper sheets are fed at all, the printer automatically goes offline, and the attention indicator will flash rapidly. Status Monitor or COMMAND CENTER can indicate the location of the paper jam (the component where the paper jam has occurred). Remove the paper jam. After removing the paper jam, the printer will resume printing.

### Possible Paper Jam Locations

The figure below shows the printer's paper paths including the optional devices. The locations where paper jams might occur are also shown here, with each location explained in the table below. Paper jams can occur in more than one component on the paper paths.

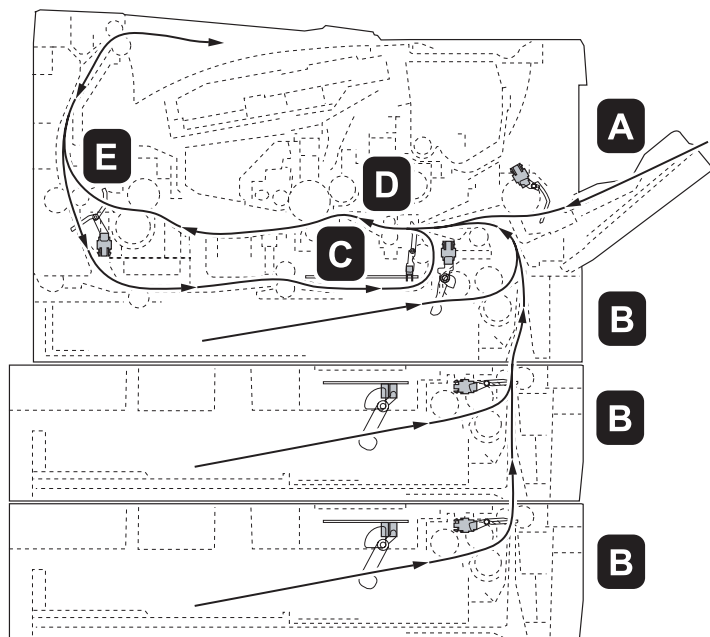

Paper jam location	Description	Reference page
A	Paper jam at the MP tray.	<i>page 5-11</i>
B	Paper jam at the paper cassette. The cassette number can be 1.	<i>page 5-12</i>
C	Paper jam inside the duplex section.	<i>page 5-13</i>
D	Paper jam inside the printer.	<i>page 5-14</i>
E	Paper jam at the rear cover.	<i>page 5-16</i>



---

## General considerations for clearing jams

Bear in mind the following considerations when attempting paper jam removal:



**CAUTION** When pulling the paper, pull it gently so as not to tear it. Torn pieces of paper are difficult to remove and may be easily overlooked, deterring the paper jam recovery.

- If paper jams occur frequently, try using a different type of paper, replace the paper with paper from another ream, or flip the paper stack over. The printer may have problems if paper jams recur after the paper is replaced.
- Whether or not the jammed pages are reproduced normally after printing is resumed, depends on the location of the paper jam.

## MP Tray

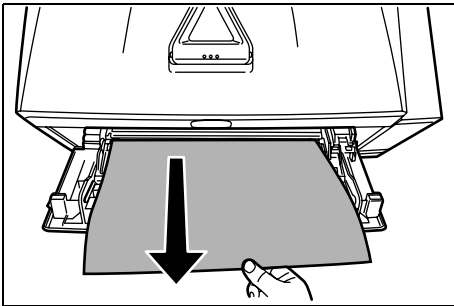

- 1 Remove the paper jammed at the MP tray.

**IMPORTANT** Do not try to remove paper that has already been partially fed. Proceed to *Inside the Printer* on page 5-14.

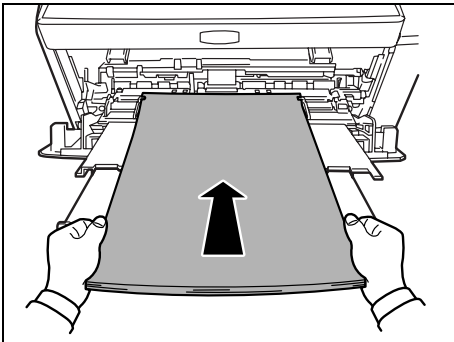

- 2 Reload the MP tray. Open and close the front cover to clear the error and the printer warms up and resumes printing.

---

## Paper Cassette/Paper Feeder

- 1 Pull out the cassette or optional paper feeder.
- 2 Remove any partially fed paper.

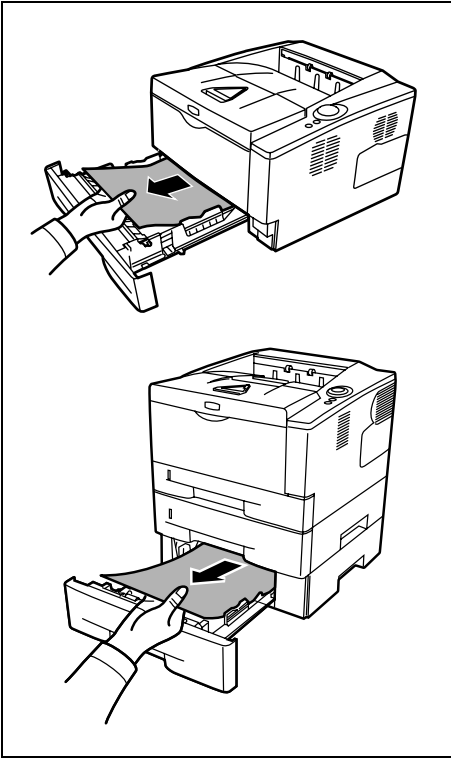

**IMPORTANT** Do not try to remove paper that has already been partially fed. Proceed to *Inside the Printer* on page 5-14.



**Note** Check to see if paper is loaded correctly. If not, reload the paper.

- 3 Push the cassette back in securely. The printer warms up and resumes printing.

---

## Duplexer

Paper is jammed in the duplex section. Remove the jammed paper using the procedure given below.

- 1 Pull the paper cassette all the way out of the printer.
- 2 Open the duplexer's cover in front of the printer and remove any jammed paper.

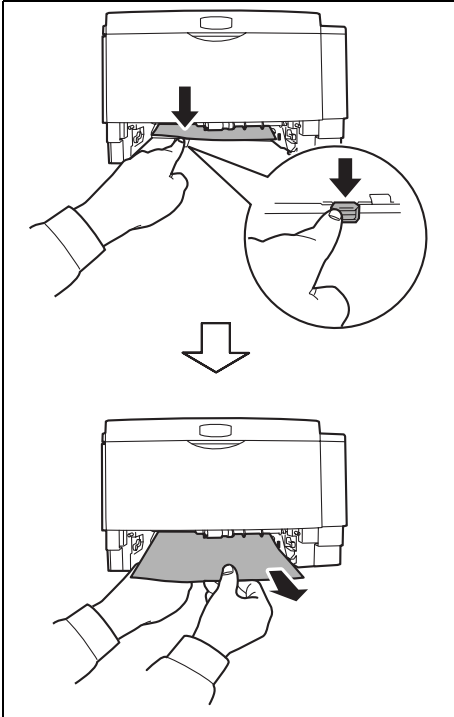

Open the duplexer's cover at the rear of the printer and remove any jammed paper.

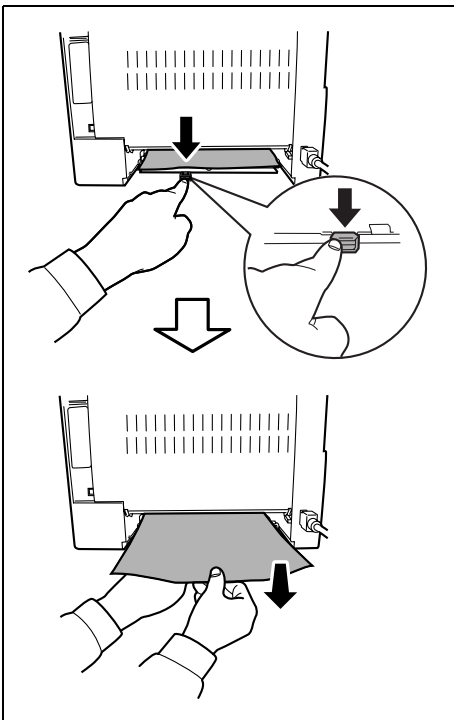

- 3 Open and close the printer's top cover to clear the error. The printer then automatically warms up and resumes printing.

## Inside the Printer

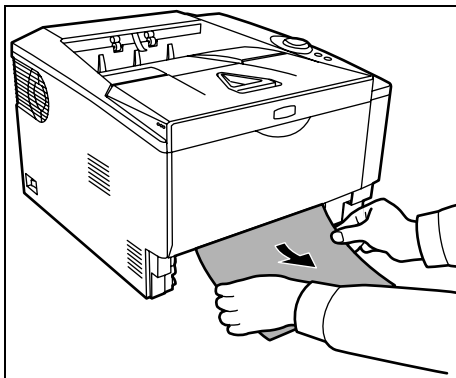

- 1 Pull the paper cassette all the way out of the printer. Remove any partially fed paper.

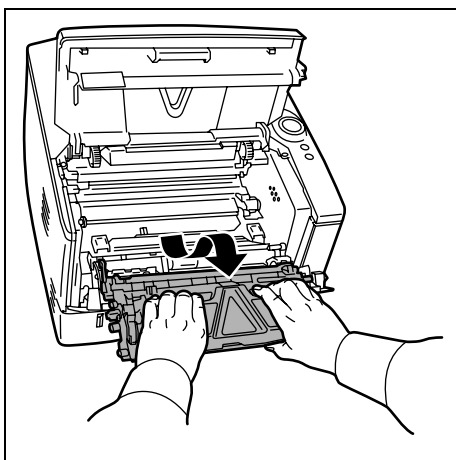

- 2 Open the top cover and front cover, and lift the process unit together with the toner container out of the printer.

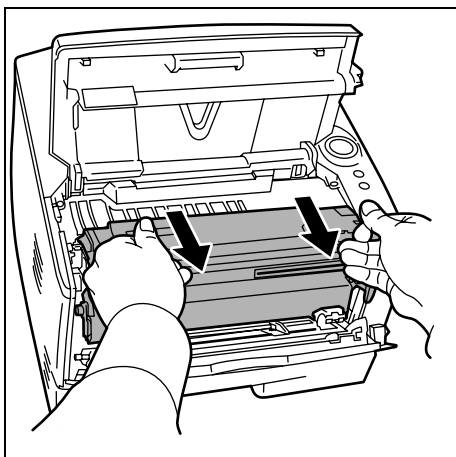

- 3 Remove the drum unit from the printer by holding the green levers with both hands.



**CAUTION** The fuser unit inside the printer is hot. Do not touch it, as it may result in burn injury.



**Note** The drum is sensitive to light. Never expose the process unit to light for more than five minutes.

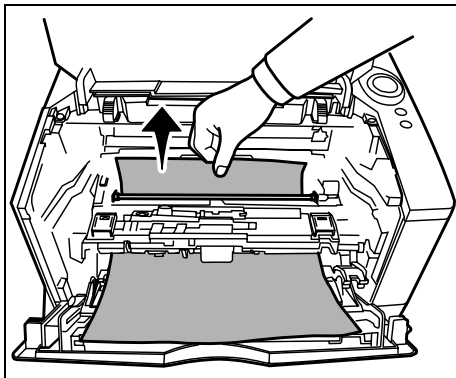

- 4 If the jammed paper appears to be pinched by rollers, pull it along the normal running direction of the paper.

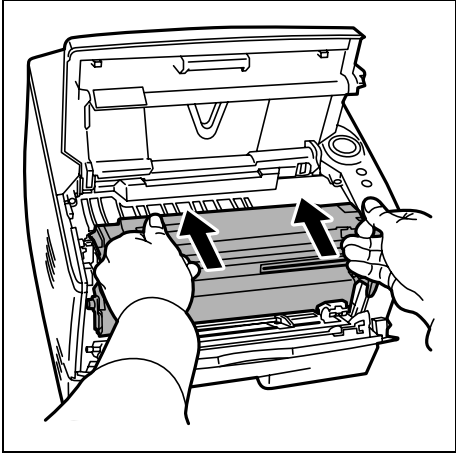

- 5 Return the drum unit to its position, aligning the guides at both ends with the slots in the printer.

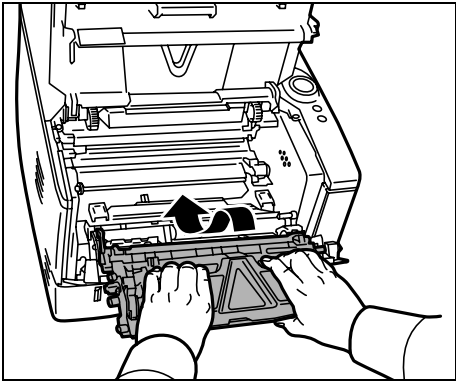

- 6 Insert the process unit together with the toner container, back into the machine. Close the top cover and the front cover. The printer warms up and resumes printing.

---

## Rear Cover

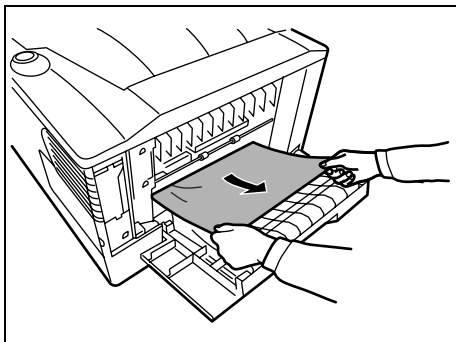

- 1 If paper is not completely ejected into the output tray, open the rear cover and remove the jammed paper by pulling it out.

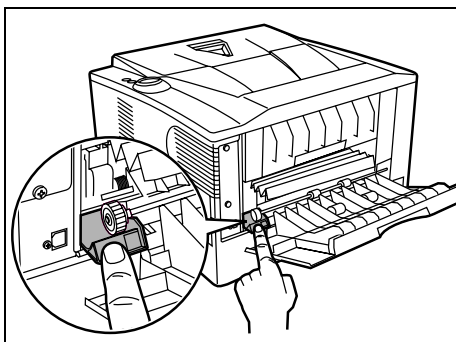

If the paper is jammed inside the fuser unit, open the fuser cover and remove the paper by pulling it out.

- 2 Close the rear cover, and open and close the top cover to clear the error. The printer warms up and resumes printing.

---

## 6 Option

---

This chapter contains explanations on the following topics:

<b>General Information</b>	<b>6-2</b>
<b>Expansion Memory Modules</b>	<b>6-3</b>
<b>PF-100 Paper Feeder</b>	<b>6-6</b>
<b>Network Interface Card (IB-23)</b>	<b>6-7</b>
<b>CompactFlash (CF) Card</b>	<b>6-8</b>

---

## General Information

The printers have the following options available to satisfy your printing requirements.

 **Note** Install the memory module before installing the optional paper feeder (PF-100).

For instructions on installing individual options, refer to the documentation included with the option. Some options are explained in the following sections.

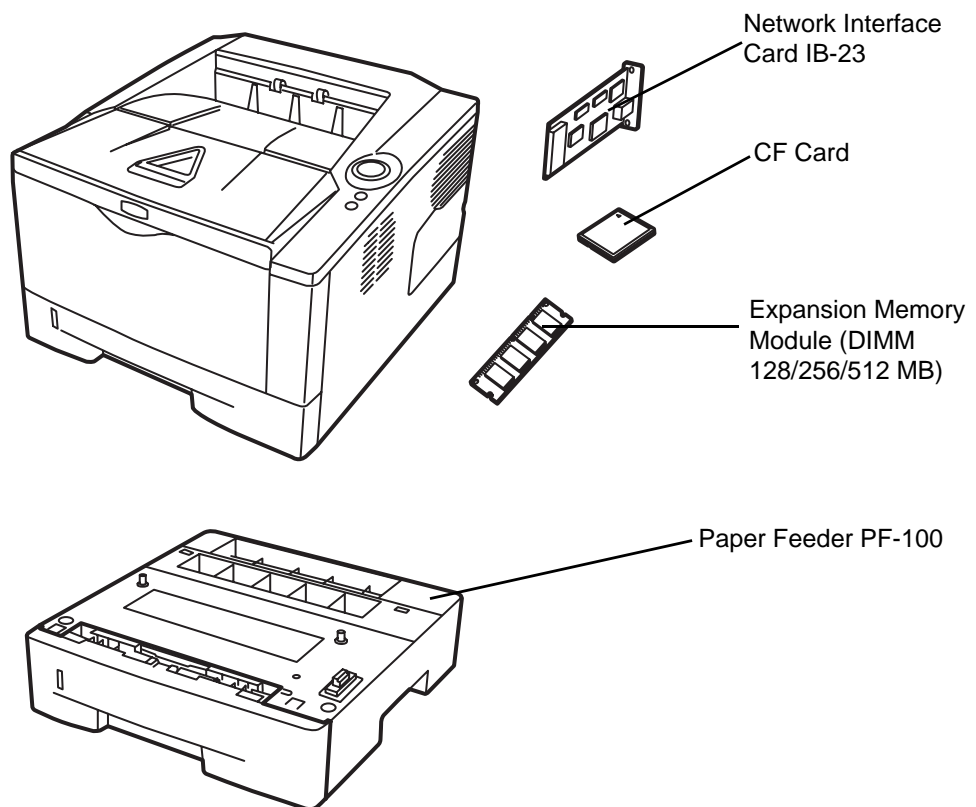



---

## Expansion Memory Modules

To expand the printer memory for more complex print jobs and faster print speed, you can plug in optional memory module (dual in line memory module) in the memory slot provided on the printer main controller board. You can select additional memory module from 64, 128, 256 or 512MB. The maximum memory size is 576MB.



**Note** The expansion memory should only be installed by your service technician. We shall not be liable for any damages caused by improper installation of expansion memory.

### Precautions for handling the printer's main controller board and memory module

To protect electronic parts, discharge static electricity from your body by touching a water pipe (faucet) or other large metal object before handling the memory module. Or, wear an antistatic wrist strap, if possible, when you install the memory module.

Always hold the main controller board or a memory module by its edges as shown below to avoid damaging electronic parts.

Correct

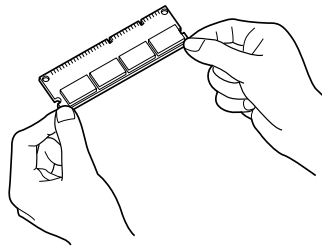

Incorrect

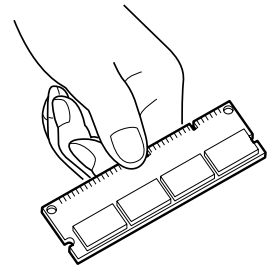

---

## Installing the Memory Module

- 1 Turn off the printer and disconnect the power cord and printer cable.
- 2 Remove the right cover with a coin.

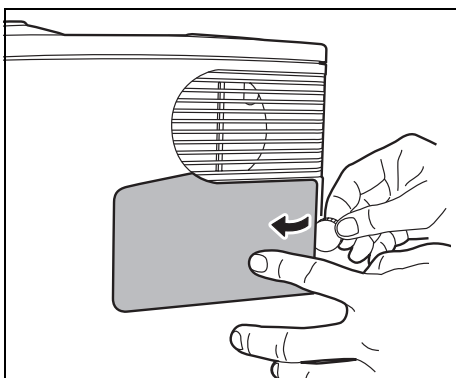

- 3 Remove the memory slot cover as shown in the figure.

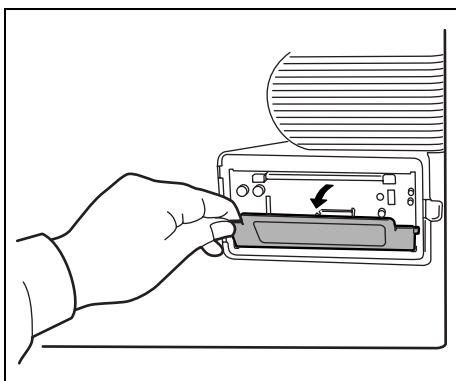

- 4 Push out the clamps on both ends of the memory socket.
- 5 Remove the memory module from its package.

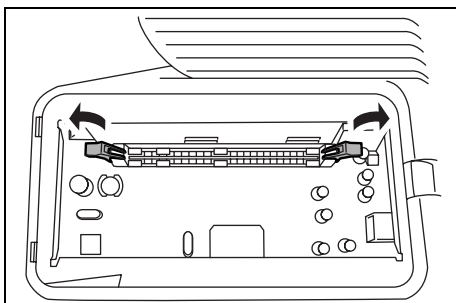

- 6 Aligning the cutouts of the memory module with the matching keys of the socket, carefully plug the memory module into the memory socket until it clicks in place.

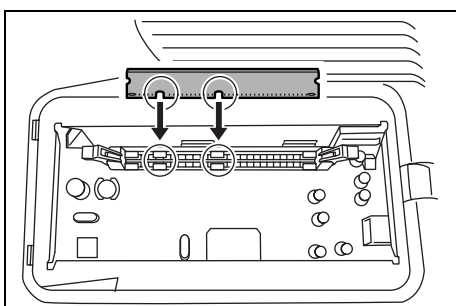

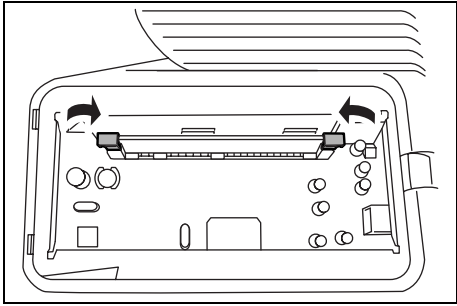

7 The memory module is secured to the memory socket with the clamps.

8 Reinstall the memory slot cover and the right cover.

## Removing a Memory Module

To remove a memory module, remove three screws from the rear of the printer, pull out the main controller board gently, then carefully push out the two socket clamps. Ease the memory module out of the socket to remove.

## Testing the expanded memory

To verify that the memory module is working properly, test it by printing a status page.

---

## PF-100 Paper Feeder

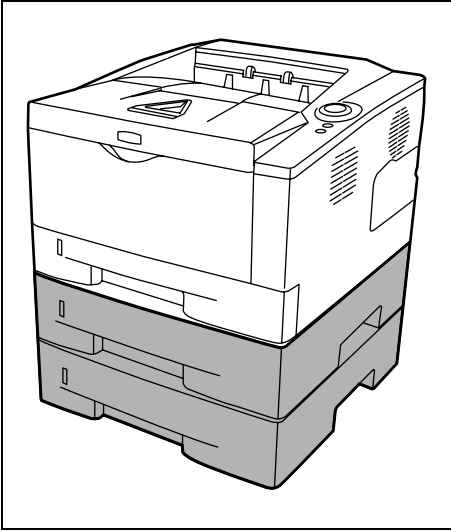

Holds approximately 250 sheets of A5 to A4/Letter and Legal size paper. Up to one paper feeder can be attached to the bottom of the printer.

The PF-100 paper feeder allows you to add two more paper cassette to the bottom of the printer for continuous feeding of a large volume of paper. Each paper cassette can hold up to approximately 250 sheets of ISO A4, ISO A5, JIS B5, Letter, or Legal size (80g/m<sup>2</sup>) paper. This feeder is attached at the bottom of the printer as shown on the left.

---

## Network Interface Card (IB-23)

Along with the standard for the network interface on the printer, the network interface card supports TCP/IP, IPX/SPX, NetBEUI and AppleTalk protocols, so that the printer can be used on network environments including Windows, Macintosh, UNIX, NetWare, etc.

The network interface card must be installed in the option interface slot that is located at the back of the printer.

- 1 Turn off the printer and disconnect the power cord and printer cable.
- 2 Open the rear cover.

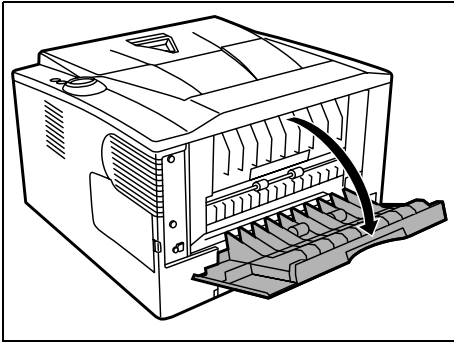

- 3 Remove the option interface slot cover.

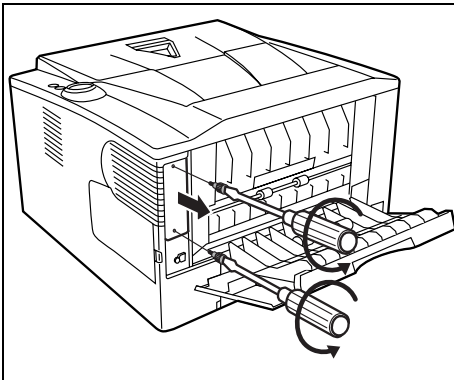

- 4 Insert the Network Interface Card and secure it with the screws removed in step 3.

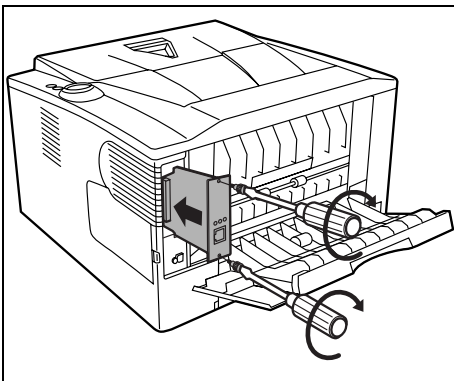

- 5 Close the rear cover, and connect the printer cable.
- 6 Connect the power cord, and turn on the printer.
- 7 Configure the network address from COMMAND CENTER. For more information, refer to *Operation Guide* of the network card.

---

## CompactFlash (CF) Card

The printer is equipped with a slot for a CF card with the maximum size of 256MB. A CF card is useful for storing fonts, macros, and overlays.

- 1 Turn off the printer and disconnect the power cord and printer cable.



**CAUTION** Before inserting a CF card in the printer, make sure that the printer is switched off.

- 2 Remove the option interface slot cover.

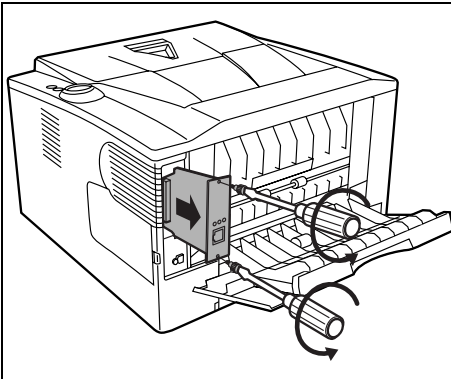
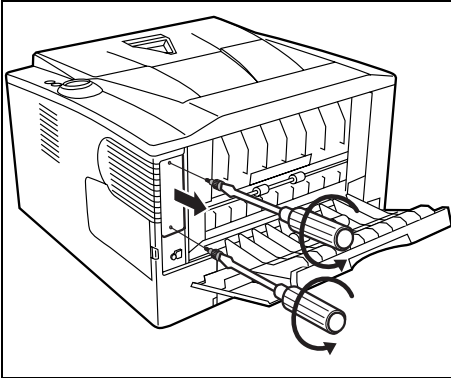

When the Network Interface Card is installed, remove it.

- 3 Insert the CF Card.

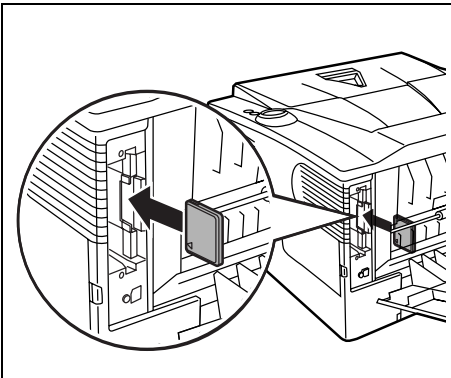

- 4 Secure it with the screws removed in step 2.
- 5 Connect the power cord and printer cable and turn on the printer.

---

# 7 Appendix

---

This section explains the specifications of this printer.

<b>Specifications</b>	<b>7-2</b>
<b>Environmental Standard Requirements</b>	<b>7-3</b>

## Specifications



**Note** These specifications are subject to change without notice.

Item		Description	
		FS-1100	FS-1300D
Type		Desktop	
Printing Method		Electrophotography, laser scan	
Paper Weight	Cassette	60 to 120 g/m <sup>2</sup>	60 to 120 g/m <sup>2</sup> (Duplex: 60 to 105 g/m <sup>2</sup> )
	MP Tray	60 to 220 g/m <sup>2</sup>	
Paper Type	Cassette	Plain, Preprinted, Bond, Recycled, Rough, Letterhead, Color (Colour), Prepunched, High Quality, Custom 1 to 8 (Duplex: Same as Simplex)	
	MP Tray	Plain, Transparency, Preprinted, Labels, Bond, Recycled, Rough, Vellum, Letterhead, Color (Colour), Prepunched, Envelope, Cardstock, Thick paper, Coated, High Quality, Custom 1 to 8	
Paper Size	Cassette	A4-R, JIS B5-R, A5, Folio, Legal, Letter-R, Oficio II, Statement, Executive, A6, B6, ISO B5-R, Envelope C5, 16K, Custom 1 to 8 (148 x 210 to 216 x 356mm/4.1 x 8.3" to 8.5 x 14")	
	MP Tray	A4-R, JIS B5-R, A5, Folio, Legal, Letter-R, Oficio II, Statement, Executive, A6, B6, ISO B5-R, Envelope C5, Envelope #10, Envelope #9, Envelope #6-3/4, Envelope Monarch, Envelope DL, Hagaki, Ofuku Hagaki, 16K, Yokei 2, Yokei 4, Custom 1 to 8 (70 x 148 to 216 x 356mm/2.8 x 5.8" to 8.5 x 14")	
Magnification ratio		25 to 400%, 1% increments	
Printing Speed	Simplex	A4/Letter: 28 ppm/30 ppm	
		A5: 17 ppm	
	Duplex	-	A4/Letter: 14 ppm/15 ppm
First Print Time (A4, feed from Cassette)		6 seconds or less	
Warm-up Time (22°C/71.6°F, 50%RH)	Power on	15 seconds or less	
	Sleep	10 seconds or less	
Paper Capacity	Cassette 1	250 sheets (80 g/m <sup>2</sup> , 11 x 8 1/2"/A4 or smaller)	
	Cassette 2	250 sheets (80 g/m <sup>2</sup> , 11 x 8 1/2"/A4 or smaller)	
	MP Tray	50 sheets (80 g/m <sup>2</sup> , 11 x 8 1/2"/A4 or smaller)	
Output Tray Capacity	Simplex	250 sheets (80 g/m <sup>2</sup> )	
	Duplex	-	200 sheets (80 g/m <sup>2</sup> )
Continuous printing		1 to 999 sheets	
Resolution		Fast 1200 mode, 600 dpi	Fine 1200 mode
Monthly Duty	Average	2,000 pages	
	Maximum	20,000 pages	



Item		Description	
		FS-1100	FS-1300D
Operating Environment	Temperature	10 to 32.5°C/50 to 90.5°F	
	Humidity	15 to 80 %	
	Altitude	2,500 m/8,202 ft maximum	
	Brightness	1,500 lux maximum	
Controller		PowerPC 405F5/360 MHz	
Supported OS		Windows 2000 Service Pack 2 or later, Windows Me, Windows XP, Windows Server 2003, Apple Macintosh OS 9.x/OS X 10.x	
Interface	Standard	Hi-Speed USB: 1	
	Option	Network Interface Card: 1 (10BASE-T/100BASE-TX/1000BASE-T)	
PDL		PRESCRIBE	
Memory	Standard	32MB	
	Maximum	544MB	
Dimension (W x D x H)		375 x 245 x 390 mm 23 13/16 x 25 3/8 x 29 5/16"	
Weight (without toner container)		10 kg/215.6 lb	
Power Source		1500 W	
Power Consumption		120 V AC, 60 Hz, 12.0 A/220 to 240 V AC, 50 Hz, 7.2 A	
Options		Expanded memory, Paper Feeder (250-sheet x 2), Network Interface Card (IB-23)	Expanded memory, Paper Feeder (250-sheet x 1), Network Interface Card (IB-23)
Operating noise (in accordance with ISO7779 [Bystander Position, sound pressure level at the front])	During printing	LpA = 53dB (A)	
	During standby	LpA = 30 dB (A)	
	During sleep mode	immeasurably low	

## Environmental Standard Requirements

This machine conforms to the following environmental standard requirements.

- Time for switching to Sleep mode (default): 15 minutes
- Duplex Printing: Standard Equipment
- Durable paper for feeding: Paper made of 100% recycled paper

**NOTE:** Contact your Dealer or Service Representative for recommended paper types.



---

# Index

---

## Numerics

---

- 3000 sheet document finisher ..... 4-9
  - 3000 sheet paper feeder ..... 4-3
    - Loading paper ..... 2-11, 2-14
- 

- Adhesive label ..... 2-7
- 

## Çª

---

- Casette
    - paper size ..... 2-4
  - Cassette
    - basis weight ..... 2-5
    - Cassette 1 ..... 1-2
- 

## ÇÎ

---

- Cleaning
    - Original platen, platen ..... 5-2
    - Document processor ..... 5-3
- 

## Çø

---

- Colored paper ..... 2-9
  - Conventions in this guide ..... xxi
  - Copy
    - Basic copying procedures ..... 3-2
- 

## D

---

- DIMM ..... 6-2
  - Document finisher ..... 4-6
  - Document processor
    - Cleaning ..... 5-3
- 

## E

---

- CFÉJÅ ..... 6-2
  - ÉÀÉÇÉäÉJÅ ..... 6-2
  - ÉÍÉbÉgÉèÀ ..... 6-2
  - Energy Star program ..... xiv
  - Envelope ..... 2-8
  - Environmental specifications ..... 7-3
  - ÉyÅ ..... 6-2
- 

## F

---

- Front cover ..... 1-3
- 

## I

---

- Installation precautions ..... xvi
- 

## J

---

- Job separator ..... 4-9
- 

## L

---

- Label ..... 2-7
  - Left cover 1 ..... 1-3
  - Left cover 2 ..... 1-3
  - Legal and safety information
    - Automatic 2-sided copy function ..... xiv
    - Energy saving control function ..... xiv
    - Energy Star program ..... xiv
    - Installation precautions ..... xvi
    - Paper recycling ..... xiv
    - Precautions for use ..... xviii
- 

## M

---

- Main power switch ..... 3-3
  - Maintenance ..... 5-1
  - MP tray ..... 1-2
    - basis weight ..... 2-5
    - minimum and maximum paper sizes ..... 2-3
    - paper sizes ..... 2-4
    - paper type ..... 2-10
  - MP tray extension ..... 1-2
- 

## N

---

- Names
    - Body ..... 1-2
    - Operation panel ..... 1-4
    - Touch panel ..... 1-5, 1-6
- 

## O

---

- Operation panel ..... 1-2, 1-4
  - Option
    - 3000 sheet document finisher ..... 4-9
    - 3000 sheet paper feeder ..... 4-3
    - Document finisher ..... 4-6
    - Job separator ..... 4-9
    - Overview of optional equipment ..... 4-2
    - Paper feeder ..... 4-2
  - Original platen ..... 1-2
    - Cleaning ..... 5-2
  - Original size indicator plates ..... 1-2
  - Output tray ..... 1-3
-

---

## P

---

Paper	
Loading paper into 3000 sheet paper feeder	2-11, 2-14
minimum and maximum sizes	2-3
Paper cassette	
minimum and maximum page sizes	2-3
Paper feeder	4-2
Paper weight	2-5
Paper width adjusting tab	2-12, 2-14, 3-2, 3-3, 3-4, 3-5, 4-6, 4-7, 5-13, 5-14, 6-4, 6-5, 6-7, 6-8
Paper width guide	2-12, 2-14, 3-2, 3-3, 3-4, 3-5, 4-6, 4-7, 5-13, 5-14, 6-4, 6-5, 6-7, 6-8
Part names	1-1
Platen	1-2
Cleaning	5-2
Postcard	2-8
Precautions for use	xviii
Preparation	2-1
Preprinted paper	2-9

## R

---

Recycled paper	2-9
----------------	-----

## S

---

Slider	1-2, 2-13
Solving malfunctions	5-2
Special paper	2-7
Specifications	
Body	7-2
Environmental specifications	7-3

## T

---

Thick paper	2-9
Toner container	1-3
Touch panel	1-5, 1-6
Transparency	2-7

---

---



**For best results and machine performance, we recommend that you use only our original supplies for your products.**



## KYOCERA MITA AMERICA, INC.

### **Headquarters:**

225 Sand Road,  
Fairfield, New Jersey 07004-0008  
TEL : (973) 808-8444  
FAX : (973) 882-6000

### **New York Branch:**

1410 Broadway 23rd floor  
New York, NY 10018  
TEL : (917) 286-5400  
FAX : (917) 286-5402

### **Northeastern Region:**

225 Sand Road,  
Fairfield, New Jersey 07004-0008  
TEL : (973) 808-8444  
FAX : (973) 882-4401

### **Midwestern Region:**

201 Hansen Court Suite 119  
Wood Dale, Illinois 60191  
TEL : (630) 238-9982  
FAX : (630) 238-9487

### **Western Region:**

14101 Alton Parkway,  
Irvine, California 92618-7006  
TEL : (949) 457-9000  
FAX : (949) 457-9119

### **Southeastern Region:**

1500 Oakbrook Drive,  
Norcross, Georgia 30093  
TEL : (770) 729-9786  
FAX : (770) 729-9873

### **Southwestern Region:**

2825 West Story Road,  
Irving, Texas 75038-5299  
TEL : (972) 550-8987  
FAX : (972) 252-9786

### **National Operation Center & National Training Center:**

2825 West Story Road,  
Irving, Texas 75038-5299  
TEL : (972) 659-0055  
FAX : (972) 570-5816

### **Latin America Division:**

8240 N.W. 52nd. Terrace Dawson Building,  
Suite 108 Miami, Florida 33166  
TEL : (305) 421-6640  
FAX : (305) 421-6666

## KYOCERA MITA CANADA, LTD.

6120 Kestrel Road, Mississauga,  
Ontario L5T 1S8, Canada  
TEL : (905) 670-4425  
FAX : (905) 670-8116

## KYOCERA MITA MEXICO, S.A. DE C.V.

Av. 16 de Septiembre #407  
Col. Santa Inés,  
Azcapotzalco México,  
D.F. 02130, México  
TEL : (55) 5383-2741  
FAX : (55) 5383-7804



## KYOCERA MITA EUROPE B.V.

Hoeksteen 40, 2132 MS Hoofddorp,  
The Netherlands  
Phone: +31.20.654.0000  
Home page: <http://www.kyoceramita-europe.com>  
Email: [info@kyoceramita-europe.com](mailto:info@kyoceramita-europe.com)

KYOCERA MITA NEDERLAND B.V.  
Beechavenue 25, 1119RA Schiphol-Rijk  
The Netherlands  
Phone: +31.20.58.77.200

KYOCERA MITA (UK) LTD  
8 Beacontree Plaza  
Gillette Way Reading Berks RG2 OBS,  
U.K.  
Phone: +44.1189.311.500

KYOCERA MITA ITALIA S.p.A.  
Via G. Verdi, 89 / 91, 20063 Cernusco s/N  
Milano, Italy  
Phone: +39.02.92179.1

S.A. KYOCERA MITA BELGIUM N.V.  
Hermesstraat 8A, 1930 Zaventem,  
Belgium  
Phone: +32.2.720.9270

KYOCERA MITA FRANCE S.A.  
Parc Les Algorithmes Saint Aubin  
91194 GIF-SUR-YVETTE,  
France  
Phone: +33.1.6985.2600

KYOCERA MITA ESPAÑA S.A.  
Edificio Kyocera, Avda de Manacor No. 2,  
28290 Las Matas (Madrid),  
Spain  
Phone: +34.91.631.8392

KYOCERA MITA FINLAND OY  
Kirvesmiehenkatu 4, 00880 Helsinki,  
Finland  
Phone: +358.9.4780.5200

KYOCERA MITA (SCHWEIZ)  
Hohlstrasse 614, 8048 Zürich  
Switzerland  
Phone: +41.1.908.4949

KYOCERA MITA DEUTSCHLAND GMBH  
Otto-Hahn-Str. 12 D-40670 Meerbusch,  
Germany  
Phone: +49.2159.918.0

KYOCERA MITA GMBH AUSTRIA  
Eduard-Kittenberger-Gasse 95,  
1230 Wien,  
Austria  
Phone: +43.1.86338.210

KYOCERA MITA SVENSKA AB  
Esbogatan 16B 164 75 Kista,  
Sweden  
Phone: +46.8.546.55000

KYOCERA MITA NORGE  
Postboks 150 Oppsal, NO 0619 Oslo  
Olaf Helsetsvai 6, NO 0694 Oslo,  
Norway  
Phone: +47.22.62.73.00

KYOCERA MITA DANMARK A/S  
Ejby Industrivej 1, DK-2600 Glostrup,  
Denmark  
Phone: +45.5687.1100

KYOCERA MITA PORTUGAL LDA.  
Rua do Centro Cultural, 41 (Alvalade) 1700-106 Lisbon,  
Portugal  
Phone: +351.21.842.9100

KYOCERA MITA SOUTH AFRICA (PTY) LTD.  
527 Kyalami Boulevard,  
Kyalami Business Park Midrand,  
South Africa  
Phone: +27.(0)11.540.2600

## KYOCERA MITA AMERICA, INC.

Headquarters:  
225 Sand Road,  
Fairfield, New Jersey 07004-0008,  
U.S.A.  
Phone: (973) 808-8444

KYOCERA MITA AUSTRALIA PTY. LTD.  
Level 3, 6-10 Talavera Road, North Ryde,  
N.S.W. 2113 Australia  
Phone: (02) 9888-9999

KYOCERA MITA NEW ZEALAND LTD.  
1-3 Parkhead Place, Albany  
P.O. Box 302 125 NHPC, Auckland,  
New Zealand  
Phone: (09) 415-4517

KYOCERA MITA (THAILAND) CORP., LTD.  
9/209 Ratchada-Prachachem Road,  
Bang Sue, Bangkok 10800, Thailand  
Phone: (02) 586-0320

KYOCERA MITA SINGAPORE PTE LTD.  
121 Genting Lane, 3rd Level,  
Singapore 349572  
Phone: 67418733

KYOCERA MITA HONG KONG LIMITED  
11/F., Mita Centre,  
552-566, Castle Peak Road,  
Tsuen Wan, New Territories,  
Hong Kong  
Phone: 24297422

KYOCERA MITA TAIWAN Corporation.  
7F-1~2, No.41, Lane 221, Gangchi Rd.  
Neihu District, Taipei, Taiwan, 114. R.O.C.  
Phone: (02) 87511560

## KYOCERA MITA Corporation

2-28, 1-chome, Tamatsukuri, Chuo-ku  
Osaka 540-8585, Japan  
Phone: (06) 6764-3555  
<http://www.kyoceramita.com>

