



**B-Net 93 60**  
**User Manual**  
01/2006

© Copyright by

**Kaba Benzing GmbH**

Albertstraße 3

D-78056 Villingen-Schwenningen

Phone +49 7720/603-0

Fax +49 7720/603-102

info@kaba-benzing.com

www.kaba-benzing.com

All rights reserved. The document and its parts are copyrighted. Only Kaba Benzing has the right to commercialize, market and distribute this document. This document, or any part of it, may not be copied or reproduced, adapted, arranged, reworked or modified without the prior consent of Kaba Benzing.

All company, trademark or product names are trademarks or registered trademarks of their respective owners and are protected.

Subject to technical changes without notice!

Order no. 04036695

<b>1</b>	<b>About this manual</b> .....	<b>5</b>
<b>2</b>	<b>Safety regulations</b> .....	<b>7</b>
2.1	Use as directed.....	7
2.2	General remarks.....	7
2.3	Installation instructions.....	7
2.4	Handling of Lithium batteries.....	8
2.5	ESD (Electro Static Discharge) protective measures.....	9
<b>3</b>	<b>Product description</b> .....	<b>10</b>
3.1	The B-Net 93 60 Terminal.....	10
3.2	Technical data.....	11
3.3	Conformity.....	13
3.4	Labeling.....	13
<b>4</b>	<b>Design and function</b> .....	<b>14</b>
4.1	How to open the housing.....	14
4.2	Housing front.....	15
4.2.1	Trimmer for display contrast.....	15
4.3	Bottom casing.....	16
4.3.1	Mains switch.....	17
4.3.2	Buffer battery.....	17
<b>5</b>	<b>Mounting and installation</b> .....	<b>18</b>
5.1	Installation conditions.....	18
5.2	Installation scheme.....	20
5.3	Installation lines.....	21
5.3.1	Power supply internal.....	21
5.3.2	Power supply external.....	21
5.3.3	Subterminal.....	21
5.3.4	Door control.....	22
5.3.5	Host connection.....	22
5.4	Wall-mounted installation.....	23
5.4.1	Direct surface mounting.....	23
5.4.2	Hole pattern.....	23
5.4.3	Using the mounting plate.....	24
5.5	Insertion of the installation cables.....	26
5.6	Connectors.....	27
5.6.1	Connections on BEX101 mother board and BECO500 CPU unit.....	27
5.6.2	Ethernet connector.....	28
5.6.3	Optional serial interface or modem.....	28
5.6.4	Analog modem.....	29
5.6.5	ISDN modem.....	30
5.6.6	RS485 interface (BEX302).....	31
5.6.7	RS232 interface (BEX301).....	34
5.6.8	RJ-45 Connection for second reader.....	34
5.6.9	Digital inputs.....	35
5.6.10	Relay outputs.....	36
5.6.11	Input 24 V.....	37
5.6.12	SV9001 power supply.....	38
5.7	Hardware options.....	39
5.7.1	BEX400 memory expansion unit.....	39
5.7.2	Uninterruptible power supply BEX500.....	40

<b>6</b>	<b>Set-up</b> .....	<b>42</b>
6.1	Set-up process.....	42
6.2	Set-up of optional hardware .....	43
6.2.1	Second reader (external reader, e.g. CCD hand scanner) .....	43
6.2.2	Replacing a reader module with other reader type .....	43
6.2.3	Host connection via partyline .....	44
6.2.4	Host connection via modem .....	44
6.2.5	Subterminal .....	45
6.3	Start options.....	46
6.3.1	Function of buttons and LEDs .....	46
6.3.2	Start of application.....	47
6.3.3	Cold start of application.....	47
6.3.4	Start of service mode .....	47
6.3.5	Start of service mode and reset to default IP .....	47
<b>7</b>	<b>BECO service module</b> .....	<b>48</b>
7.1	Start of service module .....	48
7.2	Access to the service module .....	49
7.2.1	First access .....	49
7.2.2	Access after executed network parameter setting .....	49
7.3	Service functions .....	49
7.3.1	Demands on the HTTP browser.....	49
7.3.2	Call of service functions .....	49
7.3.3	Log-in.....	50
7.3.4	Start page.....	51
7.3.5	Overview of functions .....	52
7.3.6	System monitoring and maintenance .....	53
7.3.7	Hardware settings .....	62
7.3.8	Hardware analysis.....	74
7.4	FTP access .....	77
<b>8</b>	<b>Operating elements</b> .....	<b>78</b>
8.1	Badge input.....	78
8.1.1	Contactless media .....	78
8.1.2	Mag-stripe badges and barcode badges.....	79
8.1.3	Inductive badges .....	80
8.1.4	Verification LEGIC® & Fingerprint .....	81
8.2	Matrix touch .....	82
8.3	Display illumination .....	83
<b>9</b>	<b>Maintenance</b> .....	<b>84</b>
9.1	Battery change.....	84
<b>10</b>	<b>Packaging / returns</b> .....	<b>85</b>
10.1	Devices .....	85
10.2	Electronic assemblies .....	85
10.3	Labeling .....	86
<b>11</b>	<b>Disposal</b> .....	<b>87</b>
<b>12</b>	<b>Appendix</b> .....	<b>88</b>
12.1	Dimensional drawings.....	88
12.2	Exchange of passepartout.....	89
<b>13</b>	<b>Index</b> .....	<b>91</b>

## 1 About this manual

<b>Validity</b>	<p>This Manual describes the Kaba Benzing <b>B-Net 93 60</b> terminal as of</p> <p>Serial number: 072363 - 000500</p> <p>Manufacturing date: September 2005</p> <p>Boot loader version: 2.4.0</p> <p>Service module version: 698-00-X-K03</p>
<b>Addressees</b>	<p>The manual addresses specialists for mounting, installation, set-up, service, and maintenance of the device.</p> <p>The descriptions in this manual require trained personnel. The information in this manual does not substitute for product training.</p>
<b>Content and purpose</b>	<p>The contents are limited to the assembly, installation, set-up, and basic operation of the hardware.</p>
<b>Supplemental documentation</b>	<p>Information regarding the application used by this terminal can be found in</p> <ul style="list-style-type: none"><li>• Software Manual B-Client HR3 /753, order number 04036907.</li></ul> <p>When installing the device the following remarks listed in the following Kaba Benzing manual must be considered.</p> <ul style="list-style-type: none"><li>• General installation notes, order number 04023965.</li></ul> <p>The above mentioned manuals can be found in the included</p> <ul style="list-style-type: none"><li>• Documentation &amp; Software CD ROM, order number 04033324.</li></ul>
<b>Modification log</b>	<p>Listed below are the most important changes and additions compared to the last edition of the B-Net 93 60 User Manual, 10/2005.</p> <ul style="list-style-type: none"><li>• Connection of subterminals, refer to chapter 5.6.6<ul style="list-style-type: none"><li>• Changed specification of the subpartyline buslines</li><li>• Extended description of the subpartyline</li></ul></li></ul>
<b>Orientation in the manual</b>	<p>This manual contains the following orientation guide to easier find specific topics:</p> <ul style="list-style-type: none"><li>• The table of contents in the beginning of the manual shows an overview of all topics.</li><li>• The header always contains the respective main chapter.</li><li>• An index in alphabetical order is at the end of the manual.</li></ul>

**Danger categories** Remarks with specifications or rules and restriction to prevent injuries and property damage are particularly marked.

Please read the danger warnings and user tips carefully. This information will help prevent accidents and damage to your equipment.

Danger warnings are divided into the following categories.

 **WARNING**

Describes a possibly dangerous situation that can lead to substantial bodily harm or that can lead to death.

 **CAUTION**

Describes a possibly dangerous situation that can lead to minor injuries.

**CAUTION**

Describes a possibly dangerous situation where the product itself or something near the product could be damaged.

**Symbols** If the source of danger can be precisely specified the respective symbol is prefixed.



**Hazardous voltage**



**Explosion hazard**



**Danger for electronic components due to electrostatic discharge**

**Remarks with symbols** Please pay special attention to the remarks that are marked with symbols. The symbols used in this manual have the following meaning:



**NOTICE!**

Important information for proper handling of the product. Ignoring this information can cause device malfunction.



**Remark**

Tips and useful information. This information will help you to best use the product and its functionality.

## 2 Safety regulations

### 2.1 Use as directed

The device or system is only intended for usage as described in chapter "Product Description."

Use going beyond that is not according to rules. The manufacturer is not responsible for damages resulting from improper use. The user/operator is responsible for any risks associated with non-duly use.

### 2.2 General remarks



#### **WARNING**

Hazardous voltage inside the housing!

Carelessness can lead to an electric shock.

Only skilled maintenance or service personnel may open the housing. Before you carry out maintenance works take the following measures:

- Disconnect power.
- Secure against re-starting.
- Verify that the installation is dead.

Removal of malfunctions and maintenance may only be performed by skilled technical specialists.

Only specialists authorized by the manufacturer may carry out reconstruction and modification.

All reconstructions and modifications carried out by unauthorized personnel leads to an exclusion of liability.

### 2.3 Installation instructions

Installations at the mains voltage may only be executed by a trained electrical specialist.

Only trained personnel may carry out mounting and installation.

Kaba Benzing GmbH is not liable for damages resulting from improper handling or incorrect installation.



#### **NOTICE!**

The relays are designed for 30 V AC / DC and 2 A maximum.  
For device safety reasons 115 / 230 V may not be switched with this relay.

Installation may only be carried out in places that fulfill climatic and technical conditions stated by the manufacturer.



#### **NOTICE!**

Devices that are installed outside or in splash-water endangered rooms, may not be operated with 115 / 230 V mains voltage, but must be supplied with safety extra-low voltage (24 V).

## 2.4 Handling of Lithium batteries



### CAUTION

Lithium batteries can rupture or burst like an explosive.

Improper handling of Lithium batteries can lead to fire and explosions.

- Only skilled specialists authorized by the manufacturer may exchange Lithium batteries.
- They may only be replaced by batteries of the same type.
- Do not open, bore through, or crush Lithium batteries.
- Do not burn Lithium batteries or expose to high temperatures.
- Do not short-circuit Lithium batteries.

The Lithium-ion accumulator Panasonic CGA103450 is used as buffer battery in the BEX500 UPS (optional).

These batteries may only be charged with the BEX500's charging connection.

The Lithium Manganese dioxide battery type CR 2032 is used to buffer the memory on the BEC0500 CPU board and the BEX400 add-on memory.

These batteries may in no case be recharged. The battery could overheat and melt while being recharged or even explode.



### NOTICE!

Used Lithium batteries must be disposed of according to state and local regulations.

Please carefully deposit the batteries that must be disposed, in order to avoid short-circuits, crushing, or damage of the battery housing.



## 2.5 ESD (Electro Static Discharge) protective measures



### CAUTION

Danger for electronic components due to electrostatic discharge.

Improper handling of printed circuit boards or components can cause damages that lead to complete failures or sporadic errors.

During installation and repair of the device, the ESD protective measures must be considered.

Please consider the following guidelines before the installation or maintenance of the device:

- If you deal with electronic components, always carry a wristband for the protection against electrostatic discharge. Connect one part of the wristband with a discharge socket or an unvarnished grounded metal component.
- Only touch the printed circuit boards at the edges. Do not touch the printed circuit board itself or the connector.
- Place all dismantled components on an anti-static surface or in a static-proof container.
- Avoid contact between printed circuit boards and your clothing. The wristband only protects the printed circuit boards against electrostatic discharge from the body, but there is still a risk of damage through electrostatic discharge from your clothing.
- Only transport and dispatch dismantled modules in protective bags.

### 3 Product description

#### 3.1 The B-Net 93 60 Terminal



Fig. 1: B-Net 93 60

The B-Net 93 60 is a terminal with state-of-the-art technology. Besides its primary time recording functions, the 93 60 can handle additional tasks, such as access control functions or simple PDC functions as well as project time recording.

The terminal software can be updated any time via a network connection.

The terminal features a high-contrast monochrome display with a resolution of 240 x 128 pixels. The device is operated via a 8 x 8 matrix touch where operational elements can be designed and placed individually.

Time data capture is performed with the keyless LEGIC® identification system. Reader modules are also available, including inductive; mag-stripe, barcode, chip-card; and contact-free readers such as Mifare, HID, and Hitag.

Up to four Bedanet subterminals can be connected optionally.

The built-in Ethernet interface allows integration into existing IT structures.

The terminal has 2 outputs (relays) and 4 digital inputs for control functions.

### 3.2 Technical data

<b>System</b>	<b>Processor</b>	Netsilicon NET+ARM50 ( ARM7TDMI – Core )		
	<b>Memory</b>	16MByte SDRAM / 8MByte FLASH / 1MByte SRAM, buffered, expandable by 4 MByte to 5 MByte		
	<b>Display</b>	Monochrome display with a resolution of 240 x 128 pixels		
	<b>Keypad</b>	8 x 8 matrix touch alphanumeric reader keypad (optional)		
	<b>Communication</b>	Ethernet interface 10/100 Mbps auto-sensing (Twisted Pair). Alternatively: <ul style="list-style-type: none"> <li>• Partyline RS 485 (optional)</li> <li>• Analog modem (optional)</li> <li>• ISDN modem (optional)</li> </ul>		
<b>Reader</b>	Serial reader module integrated. Available reader types: LEGIC®, inductive, mag-stripe, barcode, verification LEGIC® & Fingerprint. Other readers available on request.			
<b>Power supply</b>			with SV9001 230 V	with SV9001 115 V
	<b>Rated voltage</b>	24 V AC/DC	230 V	115 V
	<b>Voltage range</b>	12 -27 V AC 16 -32 V DC	+6 / -10%	+6 / -10%
	<b>Frequency</b>	50 -60 Hz	50 -60 Hz	50 -60 Hz
<b>Power consumption</b>	25 W max.	25 VA max.	25 VA max.	25 VA max.
<b>Environmental conditions</b>	<b>Protection class according to IEC 60529</b>	IP54 with LEGIC®, barcode, and Verification LEGIC® fingerprint reader modules. IP30 with mag-stripe and inductive reader modules.		
	<b>Relative humidity</b>	10% to 95%, non-condensing.		
	<b>Ambient temperature</b>	-10°C to +40°C, no direct sunlight.		
	<b>Use</b>	Indoors and in protected outdoor areas.		
<b>Dimensions</b>	<b>Height</b>	300 mm		
	<b>Width</b>	251 mm		
	<b>Depth</b>	120 mm		

<b>Capacity of data memory</b>	<b>Memory size</b>	<b>1 MB (Standard)</b>		<b>5 MB (optional)</b>
	<b>Data records</b>	8,000	alternatively 3,000	50,000
	<b>Master records</b>	2,000	alternatively 3,500	10,000

These specifications apply in connection with the B-Client HR3 application.

**Data retention in case of power failure**

Modified parameters, master records, and data records are retained approximately 6 months without power supply.

**Buffer time**

The optional BEX500 uninterruptible power supply allows for further operation after power failure.

Buffer time (operating time with full function) for devices with BEX500 is in case of heavy frequentation at least 90 minutes; however under typical conditions up to 4 hours.

These specifications apply to a new, fully charged accumulator in room temperature.



**NOTICE!**

Supplying the door opener with power through the BEX500 UPS is not possible.

### 3.3 Conformity



This device complies with the standards

**EN 55022**

**EN 61000-6-1**

**EN 61000-6-2**

**EN 300330**

according to the regulations of the EU guidelines

**73/23/EWG** Low voltage directive

**89/336/EWG** EMC standard

#### FCC Compliance

This device complies with Part 15 of the FCC Rules. Operation is subject to the following two conditions:

- (1) This device may not cause harmful interference, and
- (2) this device must accept any interference received, including interference that may cause undesired operation.



#### NOTICE!

Any changes or modifications not expressly approved by the party responsible for compliance could void the user's authority to operate the equipment.

### 3.4 Labeling

The identification plate is located on the bottom side of the device.

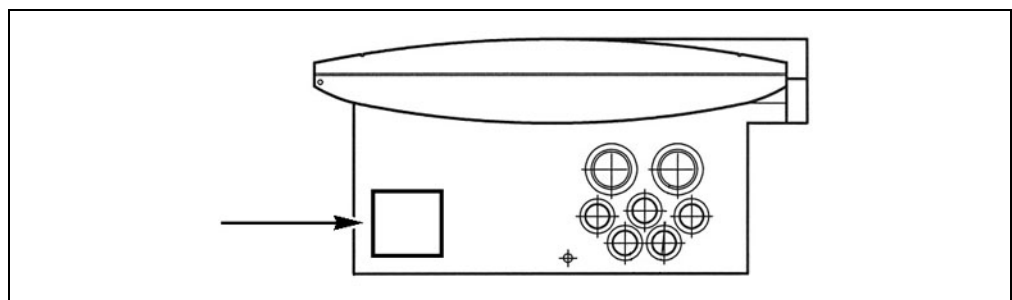

Fig. 2: Position of identification plate

On the identification plate are:

- Device name
- Product number
- Serial number
- Power data
- CE identification
- WEEE specification according to DIN EN 50419, please refer to chapter 11

## 4 Design and function

### 4.1 How to open the housing



#### **WARNING**

Hazardous voltage at clamps

Carelessness can lead to an electric shock.

- Only skilled maintenance or service personnel may open the housing.
- Disconnect power before servicing.
  - Voltage must be turned off for devices that are connected fix.
  - Devices that are fed via a separable connection, the mains plug must be pulled out.
- Secure against re-starting.
- Verify that the installation is dead.

To open the housing, please proceed as follows:

- Unlock housing front with key.
- Swing housing front to the left.



Fig. 3: How to open the housing

## 4.2 Housing front



### **CAUTION**

Display operating voltage 310 V AC (6 mA max.)

Hazard of electric shock

Avoid touching the area marked in yellow!

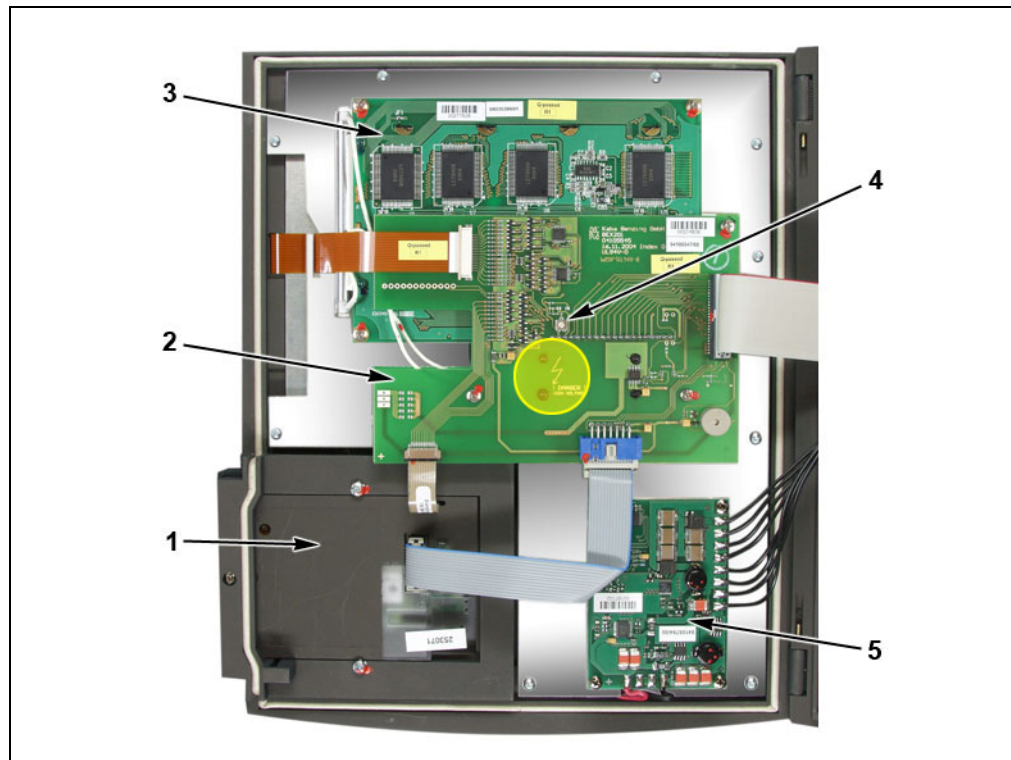

Fig. 4: B-Net 93 60 housing front with matrix touch

- 1 Serial reader module
- 2 BEX201 user interface
- 3 Display module
- 4 Trimmer for display contrast
- 5 BEX500 UPS (optional)

### 4.2.1 Trimmer for display contrast

The display contrast is set by default. Due to special conditions at the installation site (light incidence), the contrast setting may need to be corrected again.



#### **NOTICE!**

The device has an automatic temperature-sensitive contrast control. Therefore, the display contrast settings should only be carried out after the device has already been operated for at least one hour with a closed housing.

### 4.3 Bottom casing

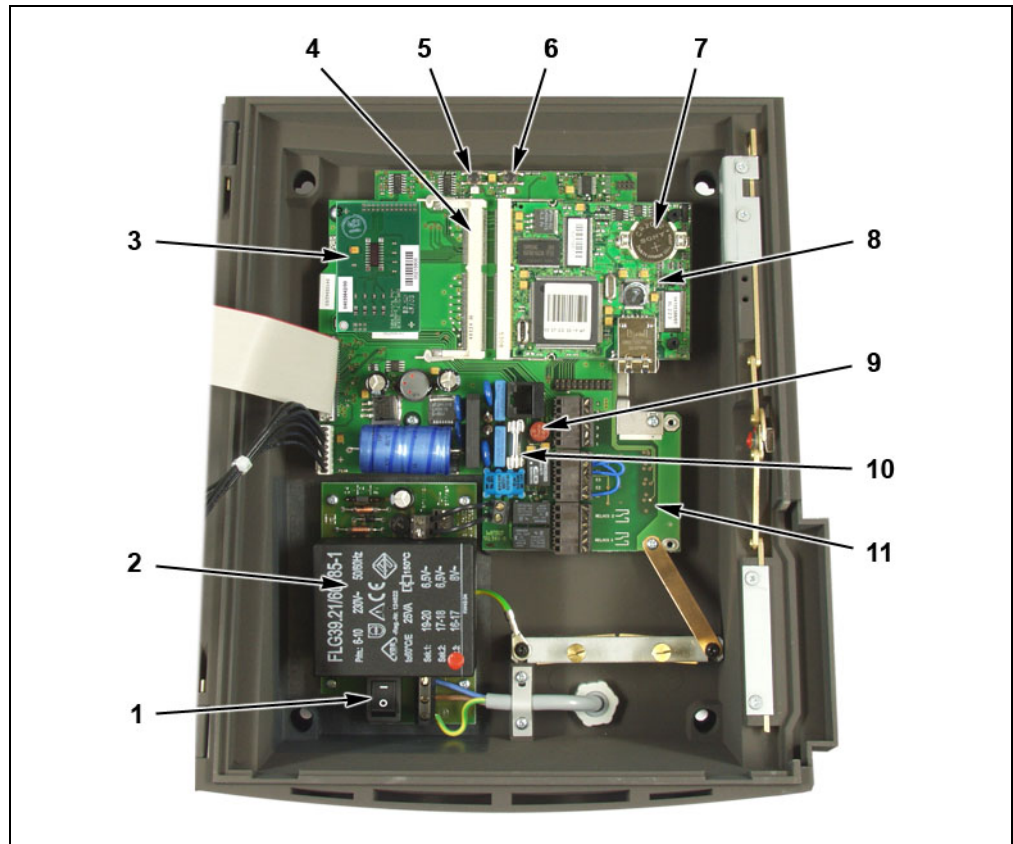

Fig. 5: Bottom casing

- 1 Mains switch
- 2 SV9001 power supply (optional)
- 3 Optional interface or modem, refer to chapter 5.6.3
- 4 Slot for BEX400 memory expansion module
- 5 Cold start button, refer to chapter 6.3
- 6 Service button, refer to chapter 6.3
- 7 Backup battery CR2032
- 8 BECO500 CPU unit
- 9 Subminiature fuse (radial) F 315 mA / 250 V  
5 V supply for second reader at RJ-45 connector on BEX101
- 10 Microfuse 5x20 (cartridge fuse) T 1.6 A / 250 V  
input circuit of 24 V terminal supply
- 11 BEX101 board



#### 4.3.1 Mains switch

The mains switch is located on the SV9001 power supply unit.

**Remark**

The internal SV9001 power supply unit with mains switch is optional and therefore not available in devices with external 24 V power supply.

#### 4.3.2 Buffer battery



To buffer modified parameters, master records, and data records, a Lithium battery type CR2032 is located on the BECO500 CPU board.

**NOTICE!**

The buffer battery must be replaced by a new one every two years. Please refer to chapter 9.1 Battery change .

## 5 Mounting and installation

### 5.1 Installation conditions

- General** An accurate installation of all components is a basic requirement for proper functioning. The following installation instructions must be adhered to.
- Connectors** At the terminal's installation site, the appropriate Ethernet connection as well as a mains voltage supply must be prepared. Mains voltage supply can be executed as stationary wiring or as separable connection.
-  **NOTICE!**  
If the mains voltage supply is executed as separable connection the following applies:
- The mains socket must be in the immediate vicinity of the device.
  - The mains plug must be freely accessible.
- For devices without an integrated power supply, the 24 V supply voltage can be supplied by the external power supply.
- Earthing** The terminal must be grounded!
- In order to ensure an ideal shielding according to EMC (electromagnetic compatibility), the conductive housing interior must be connected with earth.
- If an internal SV 9001 power supply (optional) is available, the earth lead must be connected to it.
- If no internal power supply is available, the earth lead must be routed via the external power supply and clamped to the metal holder.
- Cable inlet** The network connection, the mains voltage supply, and possibly needed signal lines can be inserted into the housing from below or from the back. Perforated holes to insert the installation cables are available in the bottom casing.
-  **NOTICE!**  
If connections are made from the back of the housing the mounting position must be defined at an early stage and discussed with the electrical fitter.
- Sun exposure** Direct illumination as well as sun exposure leads to reflections within the display area and a poor readability of the display.
-  **NOTICE!**  
Please avoid installation in places with direct sunlight.

**Splash water** Devices that are installed outside or in splash-water endangered rooms, may not be connected to the 115 V / 230 V mains voltage, but must be supplied with safety extra-low voltage (24 V).

In this case, industry-standard and waterproof screwed cable glands are to be used for the insertion of the lines into the housing.

Please consider that the International Protection class depends on the type of reader being used.



**NOTICE!**

Please arrange for a weather protection roof if installed outside.

**Clearances** Between two devices with LEGIC® readers a distance of 20 cm must be observed on all sides.

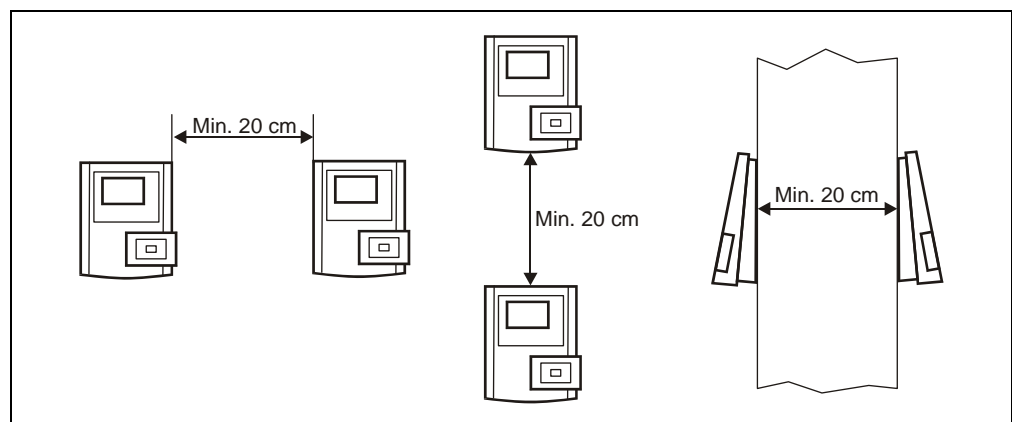

Fig. 6: Minimum distance between devices with LEGIC® readers

**Mounting height** Recommended mounting height: 150 cm to top edge of terminal.

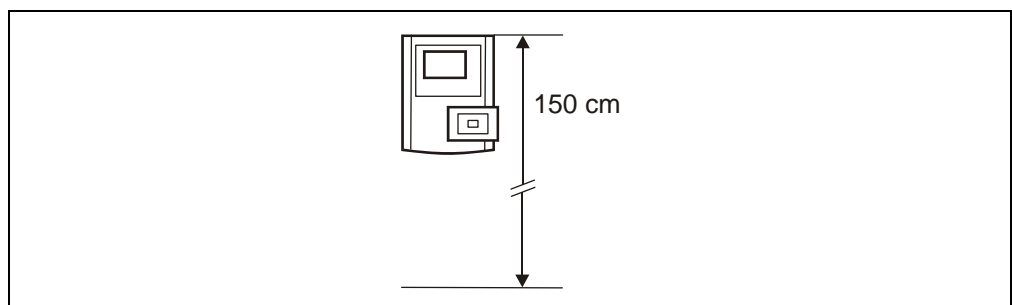

Fig. 7: Recommended mounting height

5.2 Installation scheme

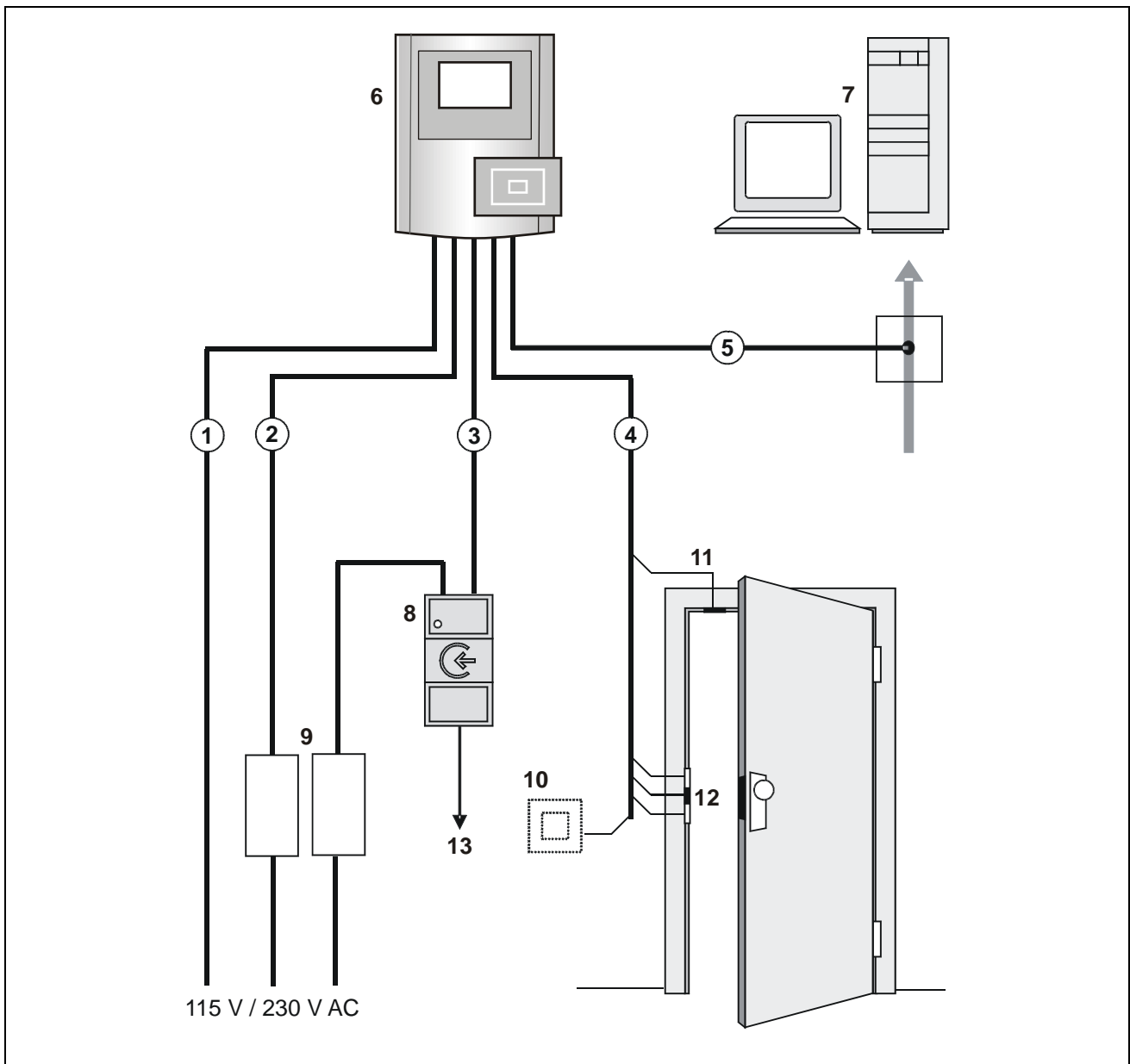

Fig. 8: B-Net 93 60 installation scheme

- |                          |   |
|--------------------------|---|
| 1 Power supply internal* | 8 Subterminal   |
| 2 Power supply external* | 9 External power supply e.g. SV905                    |
| 3 Data line subterminal  | 10 Door-opener push button                            |
| 4 Door control           | 11 Door-frame contact                                 |
| 5 Host connection        | 12 Door handle contact, door opener, and bolt contact |
| 6 B-Net 93 60            | 13 Door opener door 2                                 |
| 7 Host computer          |   |
| * alternatively          |   |

### 5.3 Installation lines

#### 5.3.1 Power supply internal

With devices that have an integrated power supply SV9001 (optional), the mains voltage supply is led to the terminal.

##### **What must be considered?**

The terminal blocks on the SV9001 power supply are designed for a wire cross section of 1.5 mm<sup>2</sup> maximum.

##### **Line requirements**

Power cord max. 3 x 1.5 mm<sup>2</sup>.

#### 5.3.2 Power supply external

Devices with 24 V input are fed with an external power supply, e.g. SV900 item no. 04021688 or SV905 item no.04033373.

##### **What must be considered?**

The terminal's housing must be grounded. It is therefore imperative to carry the ground wire from the power supply to the terminal.

In case of long lines, the voltage drop --caused by the line resistance-- must be considered.

##### **Line requirements**

Cables with a cable diameter from 0.5 mm to 0.8 mm can be used.

Three wires are required for power supply + earth (SV900).

If door-opener voltage is required, two further wires are needed (SV905).

##### **Recommended cable**

CAT.5 S-UTP 4 x 2 AWG 24 or AWG 22 (according to EIA/TIA568) or higher.

#### 5.3.3 Subterminal

The subterminals are connected via a 2-wire sub-partyline. It can be designed in star-shape or as partyline.

##### **What must be considered?**

No further signals or voltages may be carried along inside the data cable to the subterminal (e.g. door-opener triggering, door-frame contact, etc.).

A separate power supply must be provided for the subterminals.

The supply voltage for the subterminals may not be taken from the terminal, it may also not be carried along within the data cable.

The complete bus connection (master lines and branch lines) may be up to 2,000 meters long. One branch line may not exceed 100 m.

##### **Line requirements**

Shielded line with twisted wire pairs, for instance standard telephone cable J-Y (St) Y 2 x 2 x 0.6 mm.

##### **Recommended cable**

CAT.5 S-UTP 4 x 2 AWG 24 or AWG 22 (according to EIA/TIA568) or higher.

### 5.3.4 Door control

Line to door-opener, door-frame contact, door-opener push button, door handle contact, etc.

#### Line requirements

Cables with a cable diameter from 0.5 mm to 0.8 mm can be used.

#### Recommended cable

CAT.5 S-UTP 4 x 2 AWG 24 or AWG 22 (according to EIA/TIA568) or higher.

### 5.3.5 Host connection

#### Ethernet

Connecting cable from terminal to the Ethernet's RJ45 connector.

#### Line requirements

Connection takes place via 1:1 patch cable.

#### Analog modem

Connecting cable from terminal to TAE outlet.

#### Recommended cable

Data cable with TAE jack 3 m long, item no. 04106703.

#### ISDN modem

Connecting cable from terminal to RJ45 outlet.

#### Recommended cable

Telephone cable with RJ45 jack 3 m long, item no. 04106702.

#### Partyline

#### What must be considered?

The complete bus connection (master lines and branch lines) may be up to 2,000 meters long. One branch line may not exceed 100 m.

A maximum of 30 devices may be operated with one partyline.

The length of the master line or the branch line can be increased with repeaters. Please keep in mind that the connecting line of a repeater may not exceed 1,500 m. Up to 3 repeaters may be cascaded in an extension of a bus connection.

#### Line requirements

Shielded line with twisted wire pairs,  
for instance standard telephone cable J-Y (St) Y 4 x 2 x 0.6 mm.

#### Recommended cable

CAT.5 S-UTP 4 x 2 x AWG 24 or AWG 22 (nach EIA/TIA 568), or higher (CAT.6, CAT.7).

## 5.4 Wall-mounted installation

### 5.4.1 Direct surface mounting

With dowels / screws the terminal can be mounted directly to the wall.

For attachment, four mounting holes are available in the bottom casing. After opening the device, the mounting holes are accessible in the housing corners of the bottom casing.

In case of soft mounting undergrounds, make sure that when installed, the housing is not pressed into the underground.

The unevenness of the mounting surface may not exceed 0.5 mm. With spacing washers for example, a possible unevenness must be compensated or adjusted.

Recommended mounting material:

- 4 x dowel S6
- 4 x round-head wood screw DIN 96  $\varnothing$  4.5 x 35

### 5.4.2 Hole pattern

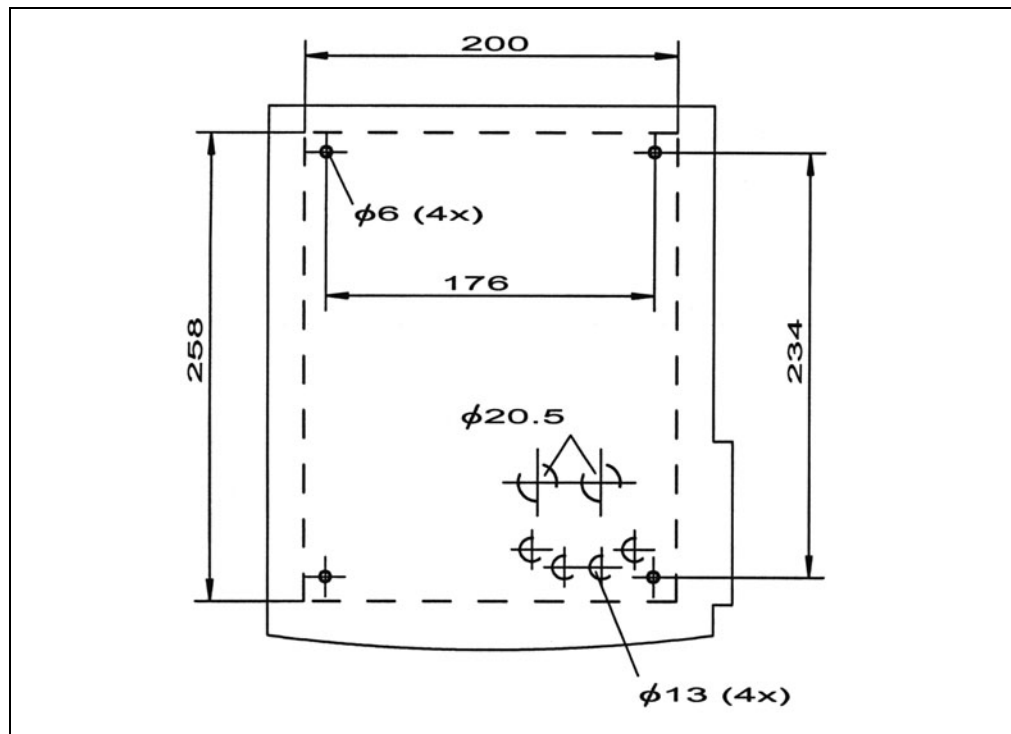

Fig. 9: Hole pattern with mounting dimension, dimensions in mm

### 5.4.3 Using the mounting plate

If you install the terminal using the mounting plate, the terminal can be quickly and easily removed from the wall.



**Remark**

The mounting plate --product number 04036599-- is an optional accessory and must therefore be ordered separately!

To mount the plate to the wall, 3 drill holes are provided.

After you attach the mounting plate to the wall, attach the terminal to the mounting plate using the two mounting holes on the back of the terminal. For protection, tighten the knurled screw at the lower end of the plate.



Fig. 10: Terminal and mounting plate

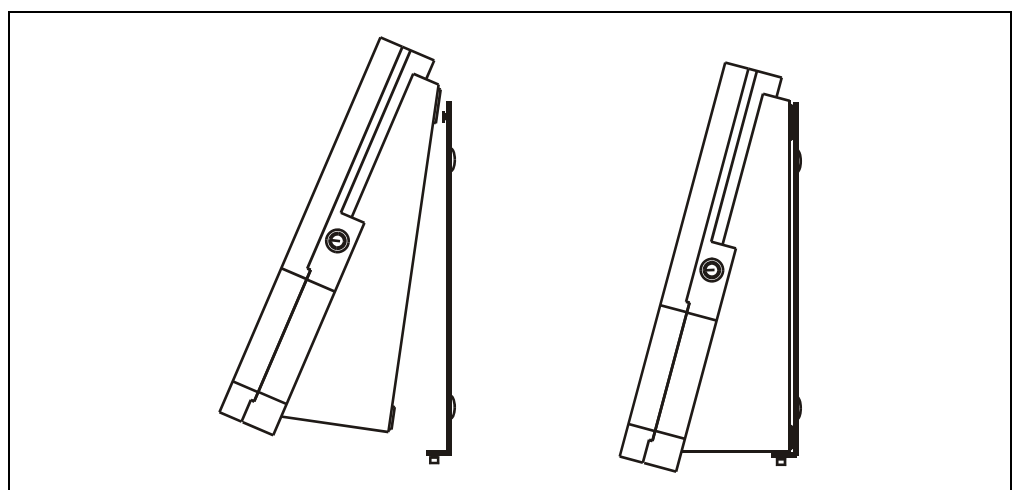

Fig. 11: Wall mounting with mounting plate



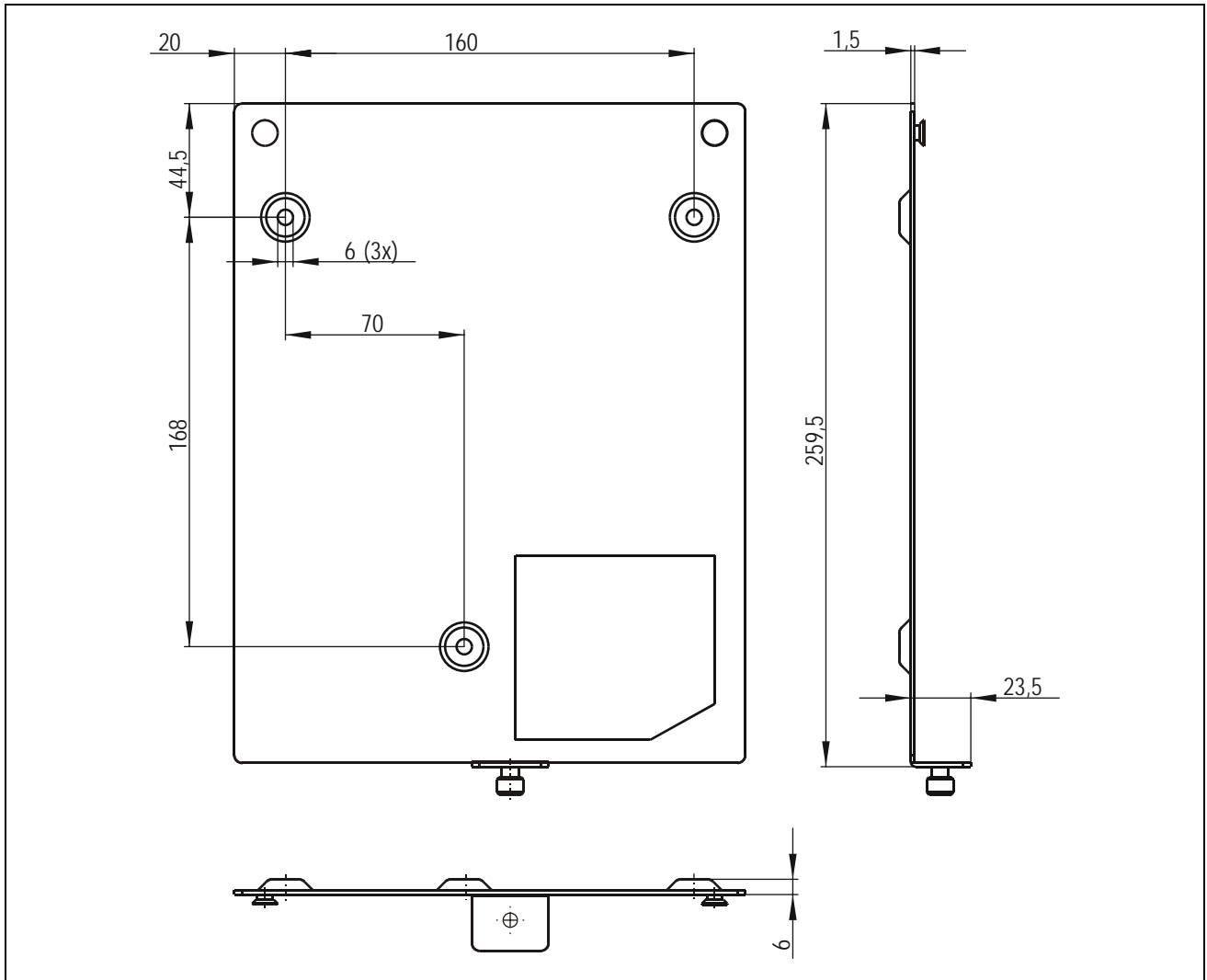

Fig. 12: Hole pattern and dimensional drawing of mounting plate

## 5.5 Insertion of the installation cables

Perforated holes to insert the installation cables are available (from below and from the back).

Cable inlet should preferably be done from the back.

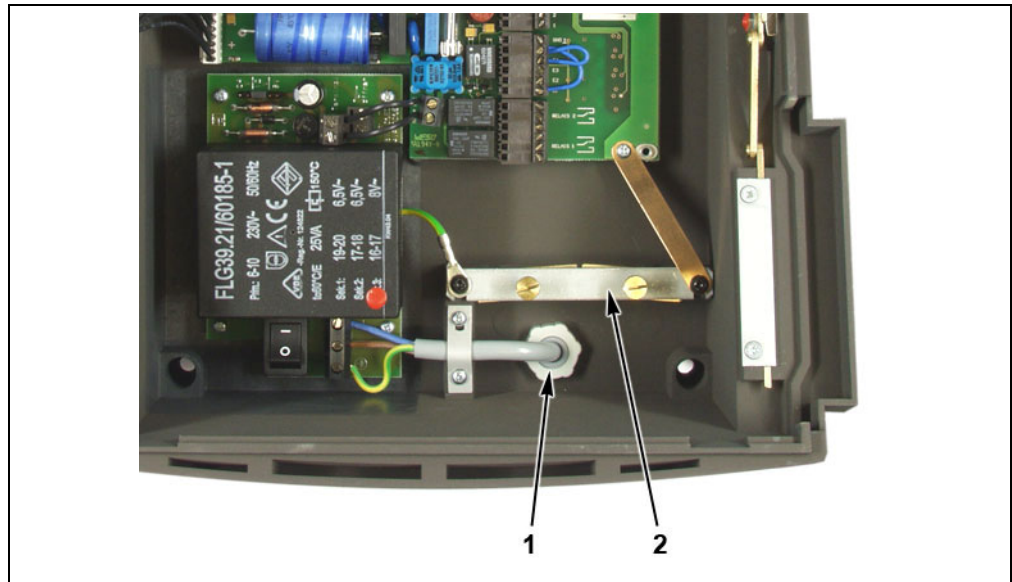

Fig. 13: Insertion of the installation cables

- 1 Cable inlet
- 2 Cable clamp

The incoming data line and the installation cables must be clamped under the clip in such a way that a conducting connection between the shielding and cable clamp develops.



### Remark

2 cable fittings PG22, 4 grommets, and a blanking plug are included in delivery.

## 5.6 Connectors

### 5.6.1 Connections on BEX101 mother board and BECO500 CPU unit

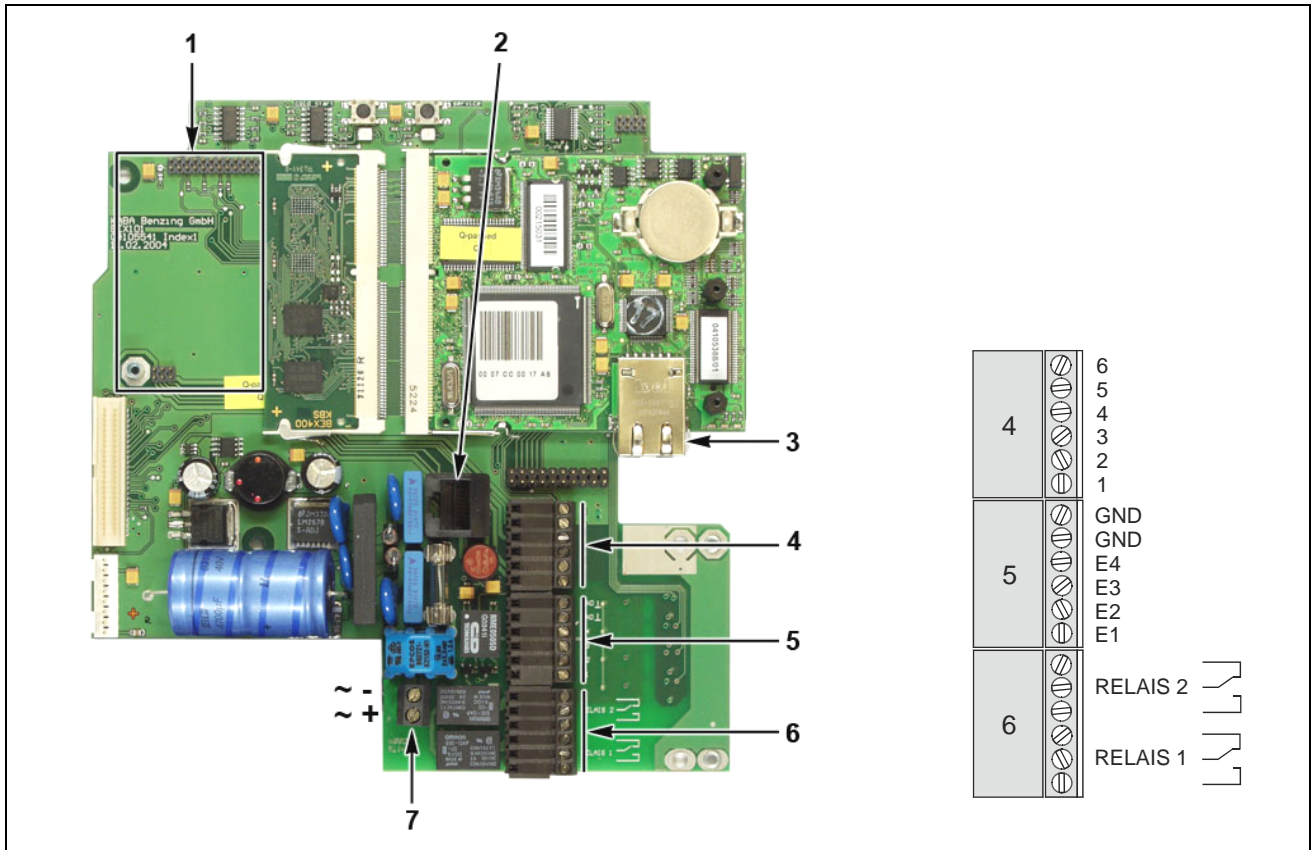

Fig. 14: Connections on BEX101 mother board and BECO500 CPU unit

- 1 Slot for optional serial interface or modem, refer to chapter 5.6.3
- 2 RJ-45 connector for second reader, refer to chapter 5.6.8
- 3 RJ-45 Ethernet connection, refer to chapter 5.6.2
- 4 Clamps for the serial interface, refer to chapter 5.6.3
- 5 Digital inputs, refer to chapter 5.6.9
- 6 Relay outputs, refer to chapter 5.6.10
- 7 Input 24 V AC / DC supply voltage for the terminal, refer to chapter 5.6.11

### 5.6.2 Ethernet connector

The BECO 500 CPU unit is equipped with a high-performance Ethernet interface, which fulfills the IEEE 802.3u 10/100 Mbps CSMA/CD standard.

Connection takes place by patch cable 1:1 via Onboard-RJ-45 socket.

Three LEDs are located on the right hand side of the Ethernet RJ-45 connection.

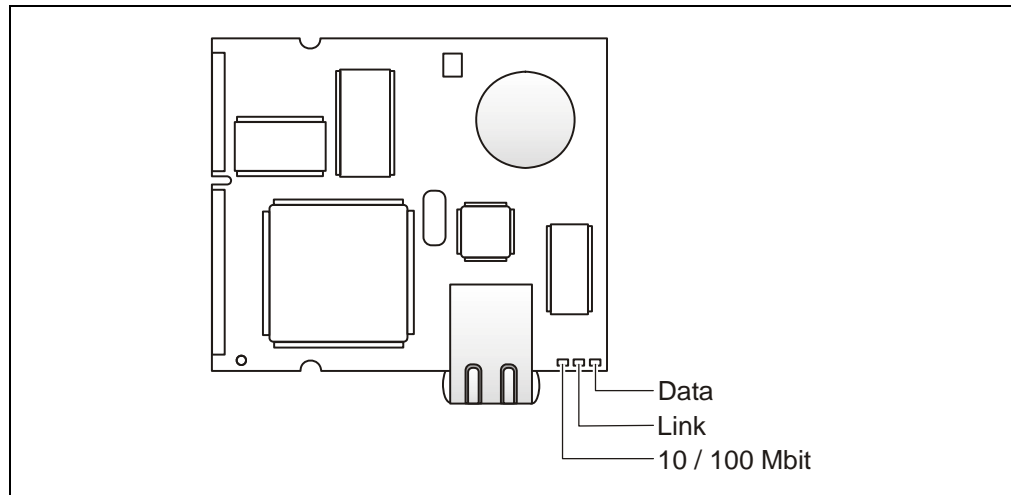

Fig. 15: Ethernet LED

#### Meaning of the light-emitting diodes

	Off	Lights up
<b>Data</b>	No data	Data transmission
<b>Link</b>	No link	Physical connection to network exists
<b>10/100 MBit</b>	10 MBit	100 MBit

### 5.6.3 Optional serial interface or modem

Clamp assignment for the serial interface depends on which optional interface is equipped.

The clamps for the serial interface are numbered in ascending order from the bottom up.

The optional interface is plugged on the BEX101 mother board and secured with a screw.



#### NOTICE!

The settings for the respective optional interface must be adapted in the BECO500 Service Module.

5.6.4 Analog modem

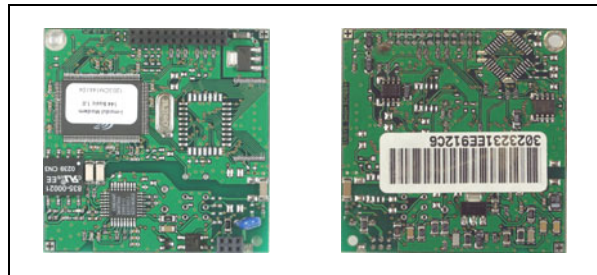

Fig. 16: Analog modem front view and rear view

**Terminal assignment BEX101**

Terminal	Specification	Function (from the terminal)
6	Earth	Line for earth key (Used with older telephone systems to occupy an exchange line). Not required with modern PBX systems (e.g. occupy exchange line with number "0").
5	-	Not used
4	A1	Series-connected telephone "A" Is detached as soon as the modem occupies the line
3	A	Incoming line (exchange / PBX) "A"
2	B1	Series-connected telephone "B" Is detached as soon as the modem occupies the line
1	B	Incoming line (exchange / PBX) "B"



**Remark**

A series-connected telephone is disconnected as soon as the modem occupies the line!

**Pin assignment TAE (telephone jack)**

Connection TAE	Assignment	Color	Clamp BEX101
1	A	Green	3
2	B	Yellow	1
3	n.c.	-	-
4	Earth	Gray/pink	6
5	B1	Brown	2
6	A1	White	4

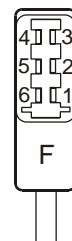

**Pin assignment RJ45 (analog)**

Connection RJ45	Assignment	Color	Clamp BEX101
1	n.c.	-	-
2	n.c.	Brown	-
3	A1	White	4
4	A	Green	3
5	B	Yellow	1
6	B1	Gray	2
7	Earth	Pink	6
8	n.c.	-	-

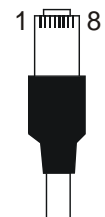

5.6.5 ISDN modem

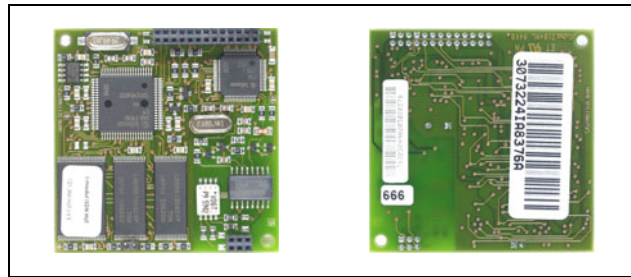

Fig. 17: ISDN modem front view and rear view

**Terminal assignment BEX101**

Terminal	Assignment	Function
6	-	not used
5	-	not used
4	STA / TX+	Transmitting line TX+
3	SRA / RX+	Receiving line RX+
2	STB / TX-	Transmitting line TX-
1	SRB / RX-	Receiving line RX-

**Pin assignment RJ45 (ISDN)**

Connection RJ45	Specification	Color	Clamp BEX 101
1	n.c.	-	-
2	n.c.	Brown	-
3	STA / TX+	White	4
4	SRA / RX+	Green	3
5	SRB / RX-	Yellow	1
6	STB / TX-	Gray	2
7	n.c.	Pink	-
8	n.c.	-	-

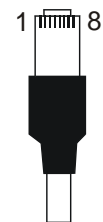

**Remark**

Modem configuration can be adapted via the BECO500 Service Module, refer to chapter 7.3.7.8.

5.6.6 RS485 interface (BEX302)



**Remark**

The RS485 interface can either be used as 2- or 4-wire partyline to the host or as 2-wire sub-partyline for the connection of subterminals.

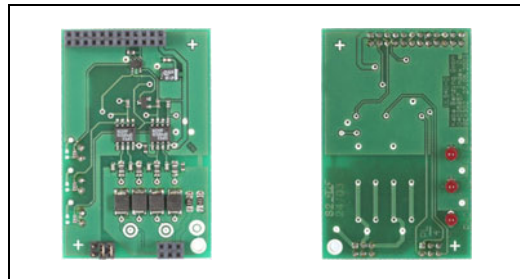

Fig. 18: BEX302 front view and rear view

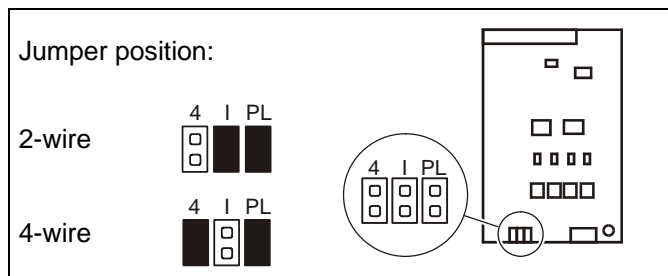

Fig. 19: BEX302 jumper assignment

**4-wire partyline to host (recommended)**

Clamp BEX 101	Specification	Function (from the terminal)	PIN assignment RJ -45 connector
6	GND	Signal ground	Shield
5	A TxD	A-line Transmit 4-wire	6
4	B TxD	B-line Transmit 4-wire	3
3	A RxD	A-line Receive 4-wire	2
2	B RxD	B-line Receive 4-wire	1
1	C	Potential compensation (C)	7+8

**2-wire partyline to host**

Clamp BEX 101	Specification	Function (from the terminal)	PIN assignment RJ -45 connector
6	GND	Signal ground	Shield
5			
4			
3	A RxD	A-line 2-wire	2
2	B RxD	B-line 2-wire	1
1	C	Potential compensation (C)	7+8

**Connection of subterminals**

The subterminals are connected via a 2-wire sub-partyline. The sub-partyline is an RS485 bus operated in 2 wire technology. It can be designed in star-shape or as partyline.

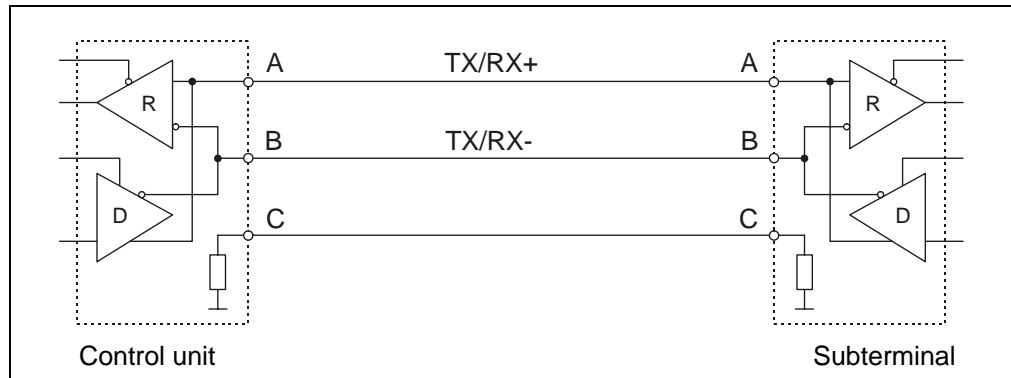

Fig. 20: Concept of 2-wire sub-partyline

Only two lines are required which are triggered half-duplex. The two bus lines are specified with A and B, whereas A does not invert the signal and B inverts the signal.

Reference potential for the interface forms the additional C line.

For the cable joints, the standard category 5 cable with 4 wire pairs, AWG 24-22 (0.5-0.65 wire-Ø), and the structure S-UTP (Screened Unshielded Twisted Pair) must be used (CAT.5).

This cable has a foil shield (screened). The wire pairs are not individually shielded against each other (unshielded). Always two wires which match in colors are twisted with each other (Twisted Pair). In accordance with EN 50 173 all 8 wires must be wired end-to-end. This way consistently structured cabling is available. Not wiring unused wires contradicts the principles of a structured cabling.

**2-wire sub-partyline**

Terminal BEX101	Specification	Function (from the terminal)	PIN assignment RJ 45 connector
6	GND	Signal ground	Shield
5			
4			
3	B TX/RX-	B-line 2-wire	2
2	A TR/RX+	A-line 2-wire	1
1	C	Potential compensation (C)	7+8

The shielding of the data line is generally connected on both sides.





**Remark**

The specifications of signal lines A and B have been swapped with Kaba Benzing's Bedas and Bedanet devices.

Specifications of signal lines with newer devices as well as with the B-Net Series are correct.

The various subterminals must therefore be wired according to the following overview.

<b>Subterminal</b>	<b>Manufacturer</b>	<b>B-Net 93 60</b>	<b>Subterminal</b>
Bedas 91 05	Kaba Benzing	A	B
Bedas 91 10	Kaba Benzing		
Bedas 91 20	Kaba Benzing	B	A
Bedas 91 40	Kaba Benzing		
Bedanet 91 04	Kaba Benzing		
Bedanet 91 05	Kaba Benzing		
Bedanet 91 20	Kaba Benzing		

<b>Subterminal</b>	<b>Manufacturer</b>	<b>B-Net 93 60</b>	<b>Subterminal</b>
Bedanet 90 20	Kaba Benzing	A	A
LR-100	Kaba AG		
LS -110	Kaba AG	B	B

### 5.6.7 RS232 interface (BEX301)

The RS232 interface (V24) is used to connect a second reader.

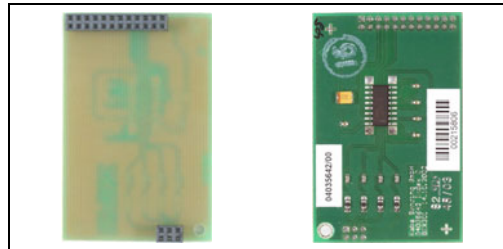

Fig. 21: BEX301 front view and rear view

### 5.6.8 RJ-45 Connection for second reader

The second serial reader can be connected to this connector. In this case the optional interface BEX301 RS232 must be equipped.

#### Assignment

Pin	Assignment
1	VCC 5 V DC; max. 200 mA
2	-
3	GND
4	-
5	TxD
6	-
7	-
8	-



#### Remarks

- Communication parameters: 9600, 8, N, 1.
- The serial interface works with RS-232 levels, not with TTL.
- Hardware handshake is not supported.
- No transmit delay of scanner data.

5.6.9 Digital inputs

Terminal	Assignment	Open / High	Ground / Low
GND	Common ground for E1 to E4		
GND			
E4	Alarm	Sabotage alarm	Idle state
E3	Block terminal	Idle state	Terminal blocks
E2	Door-opener push button	Idle state	Door opens
E1	Door-frame contact	Door open	Idle state

The inputs can be easily controlled with a simple switch or relay contact. The corresponding input is connected to common ground. An open input is recognized as "high" due to the internal pull-up resistor. Ground potential equals "low."

The input circuit also allows the control via connected potential in the following ranges:

Input voltage 30 V DC max.; min - 30 V DC

**Level**

High = + 2.6 V to + 30 V or open

Low = - 30 V to + 2.3 V

**Principle**

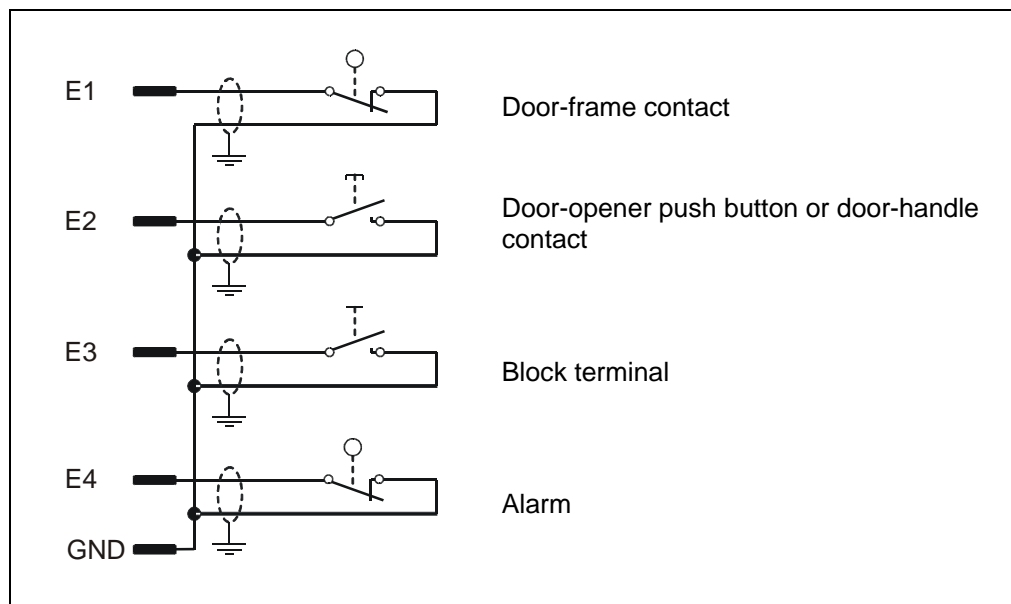

Fig. 22: Concept of digital inputs



**NOTICE!**

Do not remove the wire links at the E1 and E4 inputs if these inputs are not used!

### 5.6.10 Relay outputs

	Assignment
Relay 2	Door opener 2 (OUT)
Relay 1	Door opener 1 (IN)



#### NOTICE!

The relays are designed for 30 V AC / DC and 2 A maximum.  
For device safety reasons 115 / 230 V may not be switched with this relay.

#### Door opener

For door openers that are supplied with DC voltage, the included diode (a freewheeling diode) must be connected parallel to the door opener to suppress interference. In doing so, make sure that the diode is connected in reverse-bias direction. When using an AC voltage power supply, the included varistor type S10K30 must be connected parallelly.

The diode or varistor must be connected directly to the door opener and must **not** be fitted in the terminal.

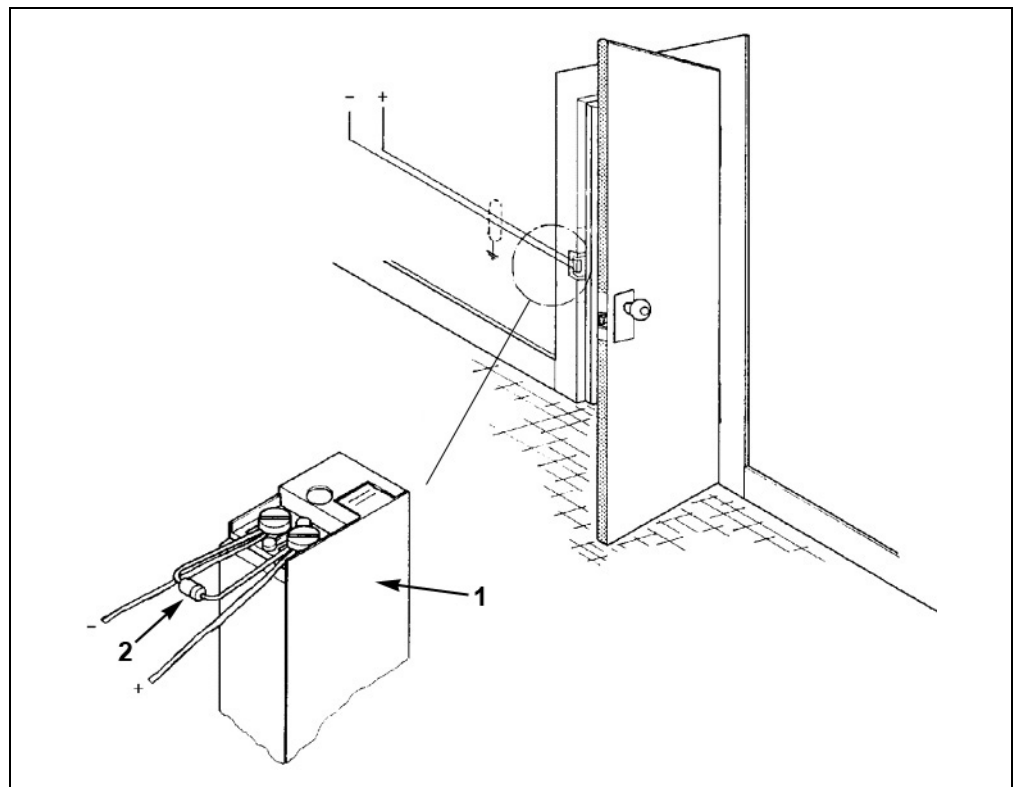

Fig. 23: Door opener

- 1 Door opener
- 2 Freewheeling diode or varistor

### 5.6.11 Input 24 V

The supply voltage for the terminal is connected to this clamp.

The supply of the terminal can take place via an integrated SV9001 (optional) or via an external power supply e.g., SV900 or SV905.

Rated voltage:	24 V AC/DC
Voltage range:	12 -27 V AC 16 -32 V DC
Frequency:	50 -60 Hz
Power consumption:	25 W max.



#### **NOTICE!**

Please make sure that the input voltage range during maximum load is observed.



#### **Important for devices with host connection via RS485!**

If several terminals are supplied with the same DC voltage, it must be considered that the polarity at the input terminals is consistent (preferably Plus at bottom).

### 5.6.12 SV9001 power supply

The terminal may be equipped with the internal power supply SV9001.

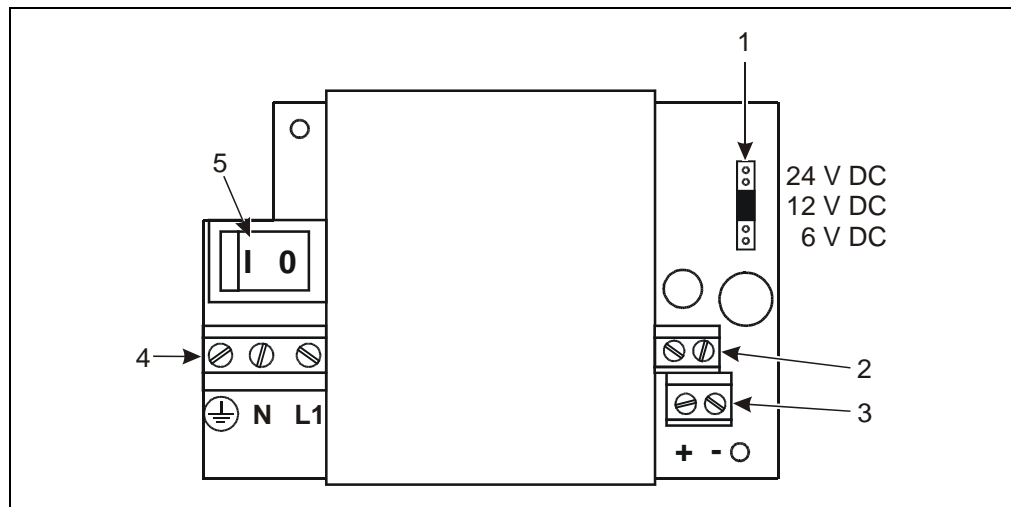

Fig. 24: SV9001 power supply

- 1 Jumper to set door-opener voltage
- 2 24 V AC operating voltage for the terminal
- 3 Operating voltage for door-opener  
24 V DC, 12 V DC or 6 V DC; depending on jumper position  
max. 4 VA 100% on-time, max. 8 VA 10% on-time
- 4 Power input 115 V AC max. 140 mA (115 V version)  
Power input 230 V AC max. 70 mA (230 V version)
- 5 Mains switch



#### NOTICE!

With the terminal's 24 V AC operating voltage (terminal 2), NO additional door-opener may be supplied.

## 5.7 Hardware options

### 5.7.1 BEX400 memory expansion unit

The BECO500 CPU unit is equipped with 1 MB internal SRAM. With the BEX400 memory expansion unit the memory space for data can be expanded with 4 MB to a total of 5 MB.

The SODIMM socket for the memory module is located on the BEX100 board.



#### NOTICE!

The BEX400 memory expansion unit is SRAM. By using DRAM or S-DRAM PC memory modules, the BECO500 CPU unit can be damaged or destroyed.



**During mounting and demounting of the BEX400 memory expansion unit, the ESD protective measures must be considered.**

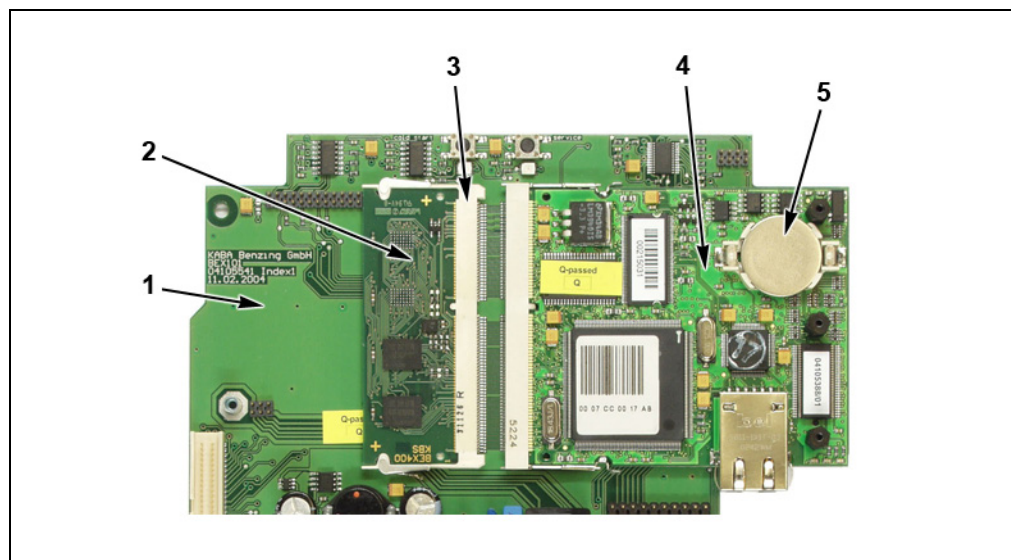

Fig. 25: BEX400 Memory Expansion Unit

- |   |                              |   |                  |
|---|------------------------------|---|------------------|
| 1 | BEX101 board                 | 4 | BECO500 CPU unit |
| 2 | BEX400 memory expansion unit | 5 | Buffer battery   |
| 3 | SODIMM socket                |   |                  |



#### NOTICE!

The SRAM sector serves as main memory with file system.

Removing the BEX400 memory expansion unit or the buffer battery on the BECO500 CPU unit in off-circuit state, leads to data and formatting loss.

After the memory extension has been mounted, the SRAM area must be newly formatted. This takes place automatically when performing a cold start. Refer to chapter 6.3.3.

## 5.7.2 Uninterruptible power supply BEX500

The terminal may optionally be equipped with the uninterruptible power supply (UPS) BEX500. The UPS is integrated right next to the serial reader in the housing front and is connected to the BEX101 mother board.

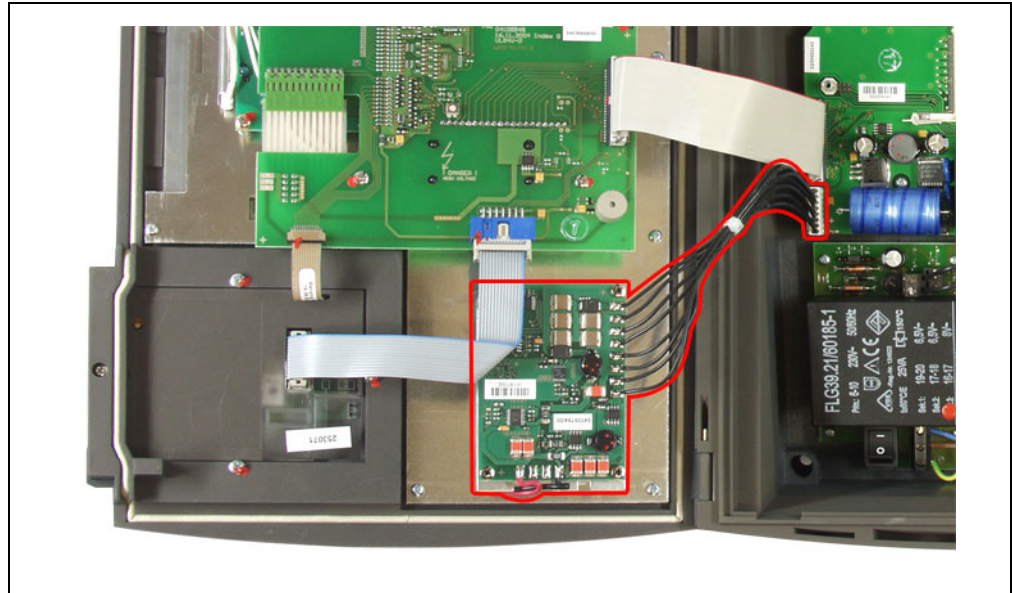

Fig. 26: BEX500 UPS

### 5.7.2.1 Technical data BEX500 UPS

Input voltage:	24 V according to rectifier level
Output voltage:	5 V
Performance:	approx. 14 Wh
Accumulator type:	2 x Panasonic CGA103450, Lithium-ion or equivalent
Accumulator power:	Voltage 8.8 to 6.0 V average 7.6 V
Accumulator capacity:	1800 mAh typical



### 5.7.2.2 Switch for emergency power operation

A micro switch is located in the upper left corner of the BEX500 printed circuit board for activation of the emergency power operation. During transport and storage, the emergency power operation must be deactivated. Charging mode is also possible.



#### Remark

The micro switch must be operated with a pointed object, e.g. pen, small screwdriver, or tweezers.

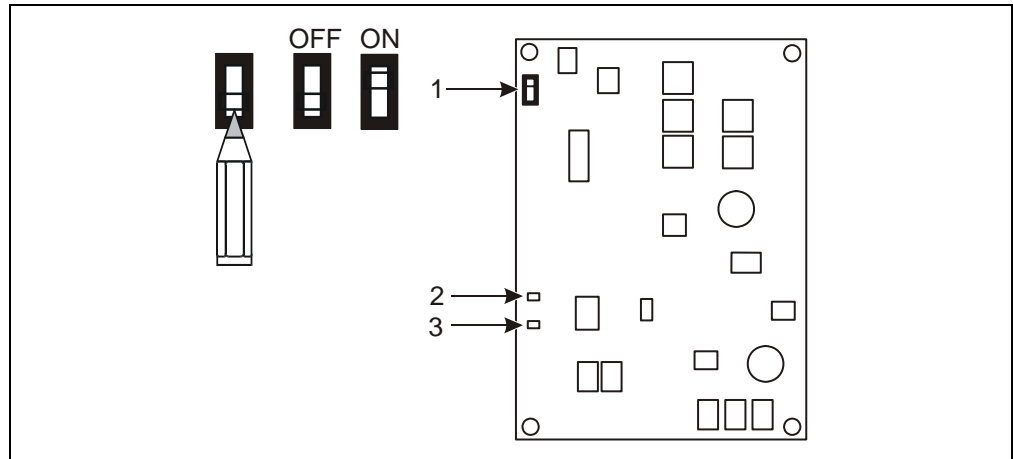

Fig. 27: BEX500 UPS switch for emergency power operation and LEDs.

- 1 Switch for emergency power operation

#### Meaning

- |   |           |           |   |                           |
|---|-----------|-----------|---|---------------------------|
| 2 | LED red   | Lights up | = | Charging                  |
|   |           | Blinks    | = | Error                     |
| 3 | LED green | Lights up | = | Accumulator > 90% charged |

## 6 Set-up

### 6.1 Set-up process

Set-up takes place as follows:

- Link service PC with the terminal.
- Start device in service mode.  
Refer to chapter 6.3.4
- Call up BECO500 service module via http browser.  
Refer to chapter 7.2
- Log in with user name: *localuser*, Password: *Bedanet*
  - Set network parameter  
*Hardware Settings / Ethernet Communication Parameter*  
Refer to chapter 7.3.7.1
  - Enter the group and device address (GID/DID) of BECO500  
*Hardware Settings / Hostline Parameters*  
Please refer to chapter 7.3.7.4
- Restart device in application mode  
*System Monitoring and Maintenance / Restart* or switch device off/on.  
Refer to chapter 7.3.6.10
- Loading of specific parameters and master records from host  
Please refer to the Manual of the used application.



#### Remark

The BECO500 Service Module is described in detail in chapter 7.

## 6.2 Set-up of optional hardware



### NOTICE!

Before the modification of devices already in operation, save parameters and master records.

After modification, the changed parameters must be sent from the communication software to the device.



### Remark regarding the use of serial interfaces (Serial Line)

Each serial interface can only be assigned to one function (Reader, Host Line or Sub Line). It must be considered that the respective interface is deactivated in the other service functions.

### 6.2.1 Second reader (external reader, e.g. CCD hand scanner)

Hardware requirements:

- The terminal must be equipped with option BEX301 (interface RS232).
- The second reader must be connected to the RJ-45 connector on the BEX101 mother board, refer to chapter 5.6.8

Settings in the service module:

- Hardware Settings/Serial Line Communication Parameter, refer to chapter 7.3.7.2
  - COM1: Enabled
  - Bits per second: 9600
  - Data bits: 8
  - Parity: NONE
  - Stop bits: 1
- Hardware Settings/Reader, refer to chapter 7.3.7.3
  - Reader 2: Enabled
  - Interface: COM1
  - Type: Barcode
- Hardware Settings/Sub Line Parameter, refer to chapter 7.3.7.5
  - Sub line: Disabled

### 6.2.2 Replacing a reader module with other reader type

Settings in the service module:

- Hardware Settings/Reader, refer to chapter 7.3.7.3
  - Reader 1: Enabled
  - Interface: COM2
  - Type: (new reader type)

### 6.2.3 Host connection via partyline

Hardware requirements:

- The terminal must be equipped with option BEX302 (interface RS485).
- The host partyline must be connected at the BEX101, please refer to chapter 5.6.6

Settings in the service module:

- Hardware Settings/Host Line, refer to chapter 7.3.7.4.
  - Host Line: Enabled
  - Interface: COM1
  - Group ID: (GID)
  - Device ID: (DID)
- Hardware settings/serial line communication parameter, please refer to chapter 7.3.7.2.
  - COM 1: Enabled
  - Bits per second: 9600
  - Data bits: 7
  - Parity: EVEN
  - Stop bits: 1

### 6.2.4 Host connection via modem

Hardware requirements:

- The terminal must be equipped with an optional internal analog modem or ISDN modem.

Settings in the service module:

- Hardware Settings/Host Line, refer to chapter 7.3.7.4.
  - Host Line: Enabled
  - Interface: COM1
  - Group ID: (GID)
  - Device ID: (DID)
- Hardware settings/serial line communication parameter, please refer to chapter 7.3.7.2.
  - COM 1: Enabled
  - Bits per second: 9600
  - Data bits: 7
  - Parity: EVEN
  - Stop bits: 1
- Initialize modem; refer to chapter 7.3.7.8

## 6.2.5 Subterminal

Hardware requirements:

- The terminal must be equipped with option BEX302 (interface RS485).
- The subterminals must be connected at the BEX101 mother board, please refer to chapter 5.6.6

Other requirement:

- To support subterminals a corresponding license key is required; refer to chapter 7.3.6.8.

Settings in the service module:

- Hardware Settings/SubLine, refer to chapter 7.3.7.5.
  - Sub line 1: Enabled
  - Interface: COM1
- Hardware settings/serial line communication parameter, please refer to chapter 7.3.7.2.
  - COM 1: Enabled
  - Bits per second: 19200
  - Data bits: 7
  - Parity: EVEN
  - Stop bits: 1

## 6.3 Start options

### 6.3.1 Function of buttons and LEDs

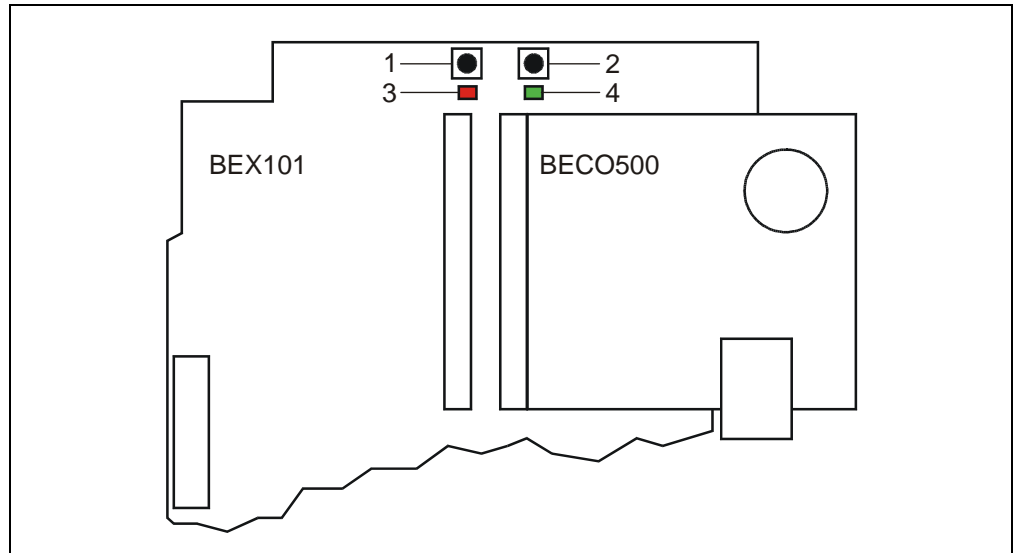

Fig. 28: Buttons and light emitting diodes on BEX101

- 1 Cold start button
- 2 Service button
- 3 LED red
- 4 LED green

The buttons allow for a system start with execution of the following start options:

- Cold start of the application, please refer to chapter 6.3.3
- Start of service mode, please refer to chapter 6.3.4
- Start of service mode and set back to default IP, please refer to chapter 6.3.5

The light emitting diodes signal if the respective start option has been executed.

LED red (3)	LED green (4)	Meaning
Lights up	Off	Application runs
Off	Lights up	Service module running
Blinks	Off	Application or service module not available

### 6.3.2 Start of application

The application is started, if neither one of the buttons is pressed during switch on.

### 6.3.3 Cold start of application

**NOTICE!**

When performing a cold start, parameters are reset to their default values. Master records and booking records are deleted.

Network settings, group and device address, as well as the INI file entries remain unchanged.

How to perform a cold start:

- Turn off the device
- Push and hold the cold start button
- Turn on device
- Release cold start button after approx. 5 seconds

### 6.3.4 Start of service mode

Performing a system start in service mode:

- Turn off the device
- Push and hold the service button
- Turn on device
- Release service button after approx. 5 seconds

### 6.3.5 Start of service mode and reset to default IP

This start option makes a start of the service mode possible with concurrent reset of the terminal IP address to default IP 123.0.0.2.

**NOTICE!**

A possibly already set IP address is overwritten, DHCP is disabled.

All other settings like host IP address, UPD port number and GID/DID remain unchanged.

Execution:

- Turn off the device
- Push and hold the service button
- Turn on device
- Release service button after approx. 12 seconds

## 7 BECO service module

The BECO (**B**enzing **E**mbdedded **C**ORE) CPU unit is used inside terminals and control units of Kaba Benzing's Bedanet and B-Net Series.

The BECO Service Module provides the functions that are required for setup, maintenance, and diagnosis. It is consistently used for all devices where the BECO is deployed.

The Service Module is an independent and from the actual terminal software autonomous application that runs on the BECO alternatively to the device software. The Service Module is there stored as "service.obf" or as "service.lzo." The file with the file extension "lzo" has a packed file format. The unpacked file format has the extension "obf."

The existing Ethernet connection is used as an interface. Communication takes place via an arbitrary system (service PC) within the network. However, the service PC can also be connected directly with the BECO. An HTTP browser with Java VM support must be installed on the service PC.

An http server and an FTP server runs in service mode. Data for the display of statistical information is stored on the BECO as HTML files. Data for the display of dynamic information is generated by the service module in Servlets / Active Server Pages (ASP) and then sent to the browser as HTML.

User dialogs for the modification of settings (e.g., date, addresses) are carried out in Java applets.

The BECO service module allows for the following functions

- Menu-driven service functions via dialog browser
- FTP access
- Local setting of communication parameters

### 7.1 Start of service module



#### **NOTICE!**

The device must be started in service mode in order to utilize the functions of the Service Module. Refer to chapter 6.3.4.

The Service Module is not available in the normal application mode.

Depending on the application active at the moment, the service mode can also be started via B-COMM or per FTP with a respective control record.

For further details please refer to the application's User Manual.



## 7.2 Access to the service module

Access to the FTP server and the HTML server of the Service Module takes place via the BECO's Ethernet connection.

### 7.2.1 First access

The default IP address 123.0.0.2 is preset on the BECO

- with ex factory delivery
- after the start of the service mode with simultaneous setting of the default IP address. For this purpose, press and hold the service button for at least 12 seconds.  
(Details about the individual start options are explained in chapter 6.3).

The network setting in the service PC must be configured accordingly, e.g. IP address 123.0.0.1. The Service PC must be in the same network segment.

For initial startup, the service PC is connected directly to the BECO via an Ethernet cross over cable (crossed RJ-45 cable).

### 7.2.2 Access after executed network parameter setting

After startup, the BECO's service module can be called up via the entered IP address.



#### Remark

A newly set IP address will be active after the device has been rebooted.

## 7.3 Service functions

The communication with the menu-driven service functions of the BECO Service Module takes place via an HTTP browser.

### 7.3.1 Demands on the HTTP browser

User dialogs for the modification of settings (e.g., date, addresses) are carried out in Java applets.

**The HTTP browser used must therefore support Java applets.**

An installed and activated Sun JRE version as of 1.4.2\_03 is required.

### 7.3.2 Call of service functions

As soon as the BECO is physically connected with the service PC, the service functions can be accessed with the help of the HTTP browser. For this purpose simply enter the BECO's IP address (default 123.0.0.2).



#### Remark

Please consider, that with an active IP address filter the proxy server must be avoided where applicable.

### 7.3.3 Log-in

If the BECO is addressed via the browser, it answers with a login mask. Here, user name and password are requested that control the access to the individual functions.

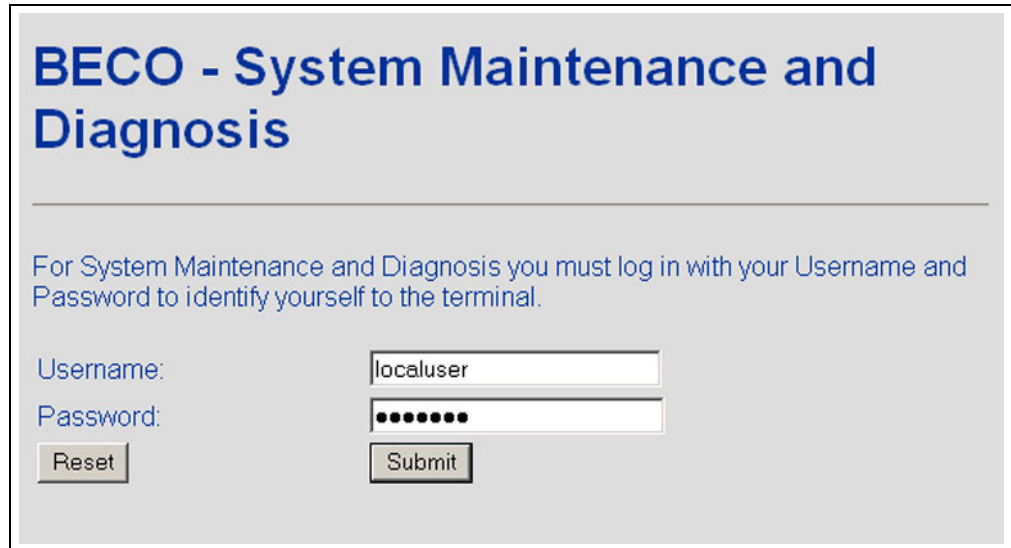

Fig. 29: Log-in mask

Enter user name and password. Then press the “Submit” button.

#### Users

The following users are already created by default:

User name	Password	Access rights	Use
<i>localuser</i>	<i>Bedanet</i>	limited	Set-up
<i>root</i>	<i>Bedanet</i>	unlimited	Expert mode