

**FCC Cautions**

Caution: Changes or modifications not expressly approved by the party responsible for compliance could void the user's authority to operate the equipment.  
 RF Exposure compliance statement: This device may be used with no restrictions, since the source-based time-averaged output power is  $\leq 60/f[\text{GHz}] \text{ mW}$ .

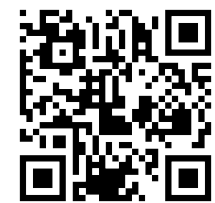

If you have a smart phone you can enter this QR code to enter [www.kamstrup.com](http://www.kamstrup.com)

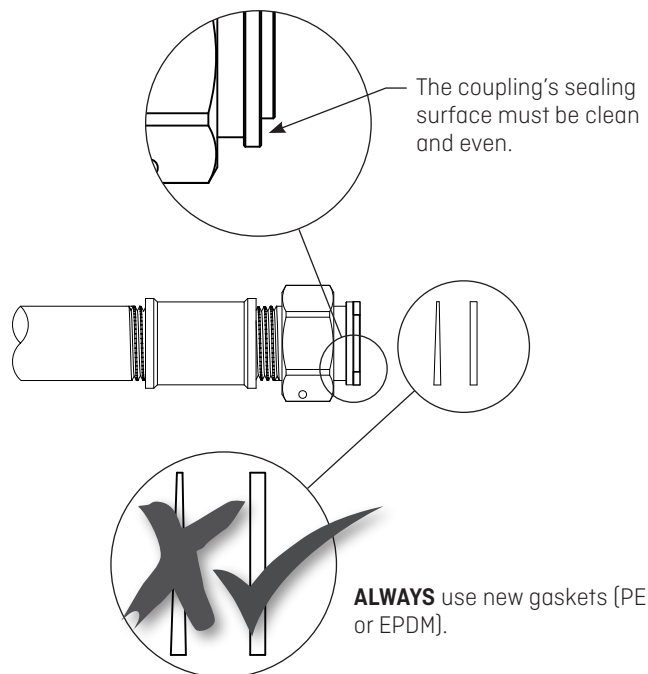

**The piping must be parallel and match the meter.**

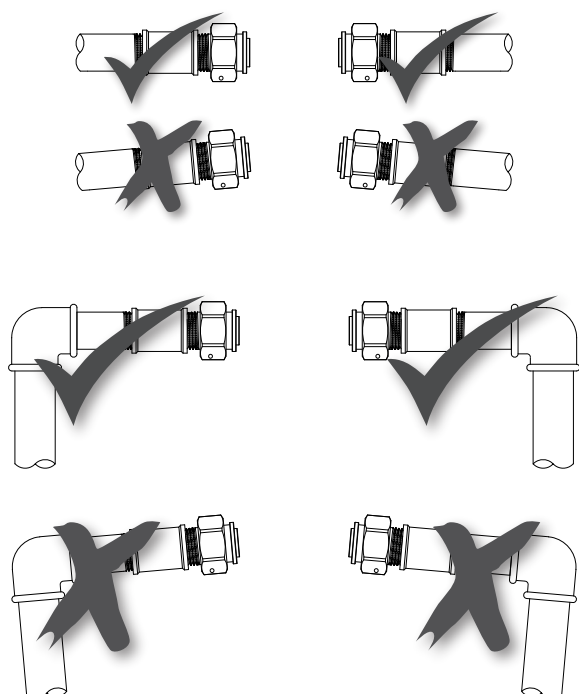

**Torque**

If a pipe installation is skew to the effect that the prescribed tightening torques would be exceeded, a telescopic coupling ought to be installed.

3/4"	Max. 15 Nm
1"	Max. 30 Nm

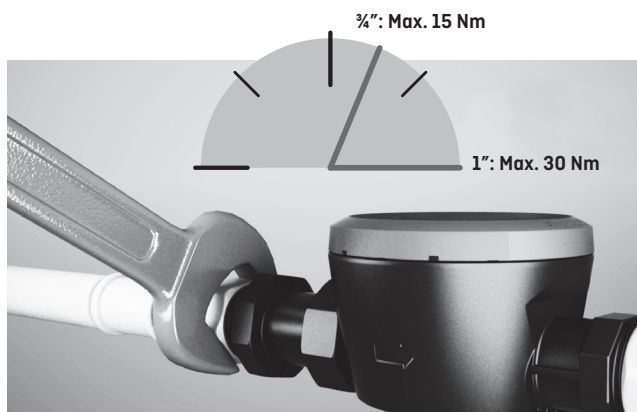

**kamstrup**

**flowIQ® 2102**

Installation guide

DRAFT-5512XXXX\_AL\_CL-GB\_06.2015



# 1. General information

Read this guide before installing the water meter.

flowIQ® 2102 is a compact electronic water meter used for water consumption measurement in the tap water supplies of homes, commercial and industrial buildings. The meter is available in two versions for cold and hot water respectively.

flowIQ® 2102 is intended for maintenance-free operation for up to 16 years depending on the installed battery type.

flowIQ® 2102 is hermetically closed, and it is, therefore, impossible to service the meter without breaking the seal. This means that all service including battery change must be carried out by an authorized Kamstrup Service Centre.

Certain changes of configuration, however, are possible via the built-in optical eye without dismantling the meter from the installation. Further details appear from data sheet and technical description.

**This device complies with Part 15 of the FCC Rules.**

**Operation is subject to the following two conditions:**

- (1) this device may not cause harmful interference, and**
- (2) this device must accept any interference received, including interference that may cause undesired operation.**

## 1.1 Permissible operating conditions / measuring ranges

Medium temperature cold water meter:	0.1°C...50°C
Medium temperature hot water meter:	0.1°C...70°C
Pressure stage:	PN16
Mechanical environment:	M1 Fixed installation with minimum vibration.
Electromagnetic environmental class:	E1 and E2. Residential and commercial
Protection class:	IP68
Climatic environment:	2°C...55°C. Condensing humidity. (indoors mounted in utility rooms and outdoors in meter wells). Installation in direct sunlight must be avoided.

## 1.2 Installation requirements

Prior to installation of flowIQ® 2102 the system should be flushed while a fitting piece replaces the meter. Mount the meter with couplings. You must always use new gaskets in original quality.

Following gaskets can be used:

	Cold water	Hot water
¾"	2 mm EPDM or PE	2 mm PTFE with silicate fill
1"	3 mm EPDM or PE	3 mm PTFE with silicate fill

The flow direction is indicated by an arrow on the side of the meter housing.

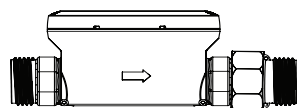

During installation it must be secured that the meter is mounted without mechanical bias in the connection pipes. The couplings must be tightened with maximum the following torque:

¾"	15 Nm
1"	30 Nm

If a tight connection cannot be obtained within these limits, the pipe installation must be corrected in order to remove strains. Alternatively, a telescopic coupling must be installed.

Such couplings can be supplied by Kamstrup A/S.

For sealing you can use the sealing wire holes on the lower side of the threaded connections.

Mounting the meter you must make sure that the threaded length of the couplings does not prevent proper tightening of the sealing surface, and that PN10 or PN16 couplings are used. flowIQ® 2102 has a large-meshed strainer (filter) pre-mounted in the meter inlet socket.



For both meter sizes 2.5 m³/h and 4.0 m³/h, a nonreturn valve, to be mounted concealed in the meter outlet socket, is available. Thin 2 or 3 mm gaskets must be used for mounting. Non-return valve must be pressed into the outlet of the meter; the black o-ring pointing inwards in the meter. Press firmly the valve, into the meter outlet socket, until it reaches limit stop.

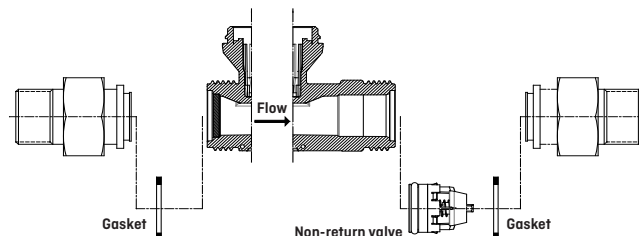

## Service

When the meter has been mounted in the system, neither welding nor freezing is allowed. Dismount the meter from the system before starting such work.

In order to facilitate replacement of the meter, closing valves should be mounted on both sides of the meter.

Under normal operating conditions no pipe strainer is required in front of the meter. Non-return valves must be mounted according to national local regulations.

## 1.3 Installation angle of flowIQ® 2102

flowIQ® 2102 can be mounted at all angles and positions. Kamstrup A/S recommend that the display is mounted so that it is easy to read, if possible.

Thus, the meter can be mounted in a usual horizontal installation. It can be mounted vertically in an ascending pipe, it can be mounted at any angle and it can be mounted with its display facing down, e.g. under a roof.

Mounting the meter in a downpipe, you must be aware that the display in that case will be 'upside-down'.

## 1.4 Straight inlet

flowIQ® 2102 requires neither straight inlet nor straight outlet to meet the Measuring Instruments Directive (MID) 2004/22/ EC and OIML R49. A straight inlet section will only be necessary in case of heavy flow disturbances before the meter.

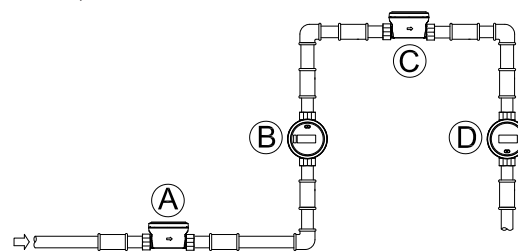

- A** Recommended water meter position.
- B** Recommended water meter position.
- C** Used for "pit installation". Air build-up may occur.
- D** The meter functions optimally, but the display is 'upside-down'.

## 1.5 Operating pressure

In order to avoid cavitation and secure correct measurement, under all circumstances, the operating pressure in the pipe installation must observe the test conditions of OIML R 49, which means that the static pressure immediately after the meter (downstream) must always be minimum 0.03 MPa (0.3 bar).

## 1.6 Info codes and display

When flowIQ® 2102 leaves Kamstrup A/S, it has been tested and verified and the counter has been reset.

The number of m³ is displayed by five large digits. The small digits are decimals after the point.

A number of info codes can be displayed, of which DRY and RADIO OFF will be activated and flash upon delivery. Furthermore, the two small squares in the bottom right-hand corner flash to indicate that the meter is active.

Info code DRY indicates there is air in the meter; the info code disappears when the meter is water-filled.

The info code RADIO OFF indicates that the meter is still in transport mode with the built-in radio transmitter turned off. The transmitter turns on automatically when the first litre of water has run through the meter. The radio transmitter remains on, and the info code signal in the display switches off.

The flow arrows in the left side of the display indicate water flow through the meter. If the water is stagnant, all arrows will be off. The table below describes the different info codes in the display.



The figure after the 'A' states how many times the meter has been adjusted. In a completely new meter both of these characters will be out.

Laboratories which have reverified and adjusted or reset the meter must supply the meter with a label with information on the current adjustment figure.

Info code flashes in the display	Meaning
LEAK	The Water has not been stagnant in the meter for minimum one continuous hour during the latest 24 hours. This can be a sign of a leaky faucet or toilet cistern.
BURST	The water flow has exceeded a preprogrammed limit for minimum 30 minutes which is a sign of a burst pipe.
TAMPER	Attempt of fraud. The meter is no longer valid for billing purposes.
DRY	The meter is not water-filled.
REVERSE	The water flows through the meter in the wrong direction.
RADIO OFF	The meter is still in transport mode with the built-in radio transmitter turned off. The transmitter turns on automatically when the first litre of water has run through the meter.
■ ■ (two square 'dots')	Two small squares alternately flashes, indicating that the meter is active