

Mounting of antenna

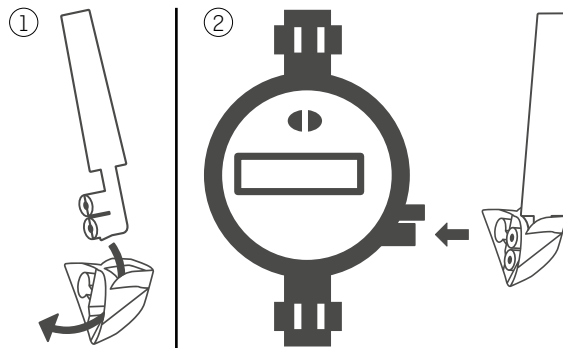
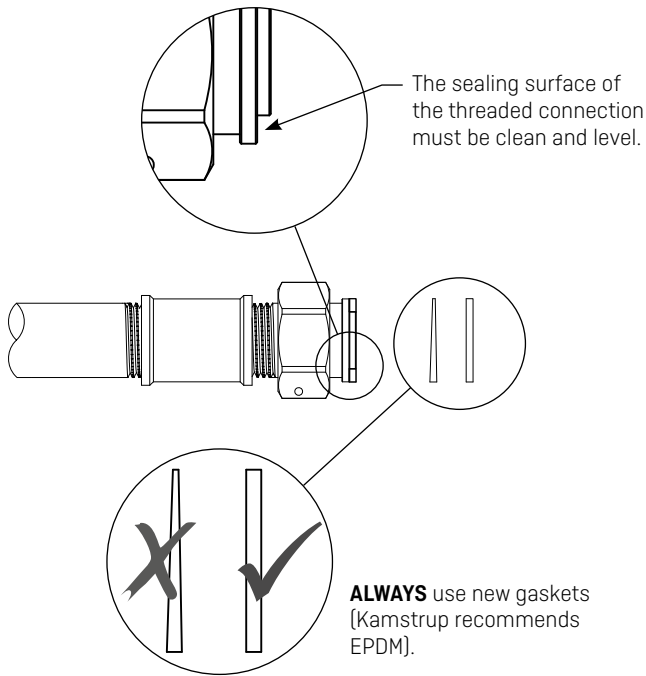

Step 1: Push the base of the helix antenna through the seal housing.
 Step 2: Align the antenna by using the terminals and steering pin before clicking it into place.

NOTE! The antenna must only be mounted on the meter with the antenna pointing upwards.
 Make sure the terminal is dry and clean before clicking the antenna into place.

FCC Cautions
 Caution: Changes or modifications not expressly approved by the party responsible for compliance could void the user's authority to operate the equipment.
 RF Exposure compliance statement: This device may be used with no restrictions, since the source-based time-averaged output power is $\leq 60 \text{ mW}/(\text{ft}^2 \cdot \text{MHz})$.
 This device complies with Part 15 of the FCC Rules.
 Operation is subject to the following two conditions:
 1 This device may not cause harmful interference, and
 2 This device must accept any interference received, including interference that may cause undesired operation.

The adjacent piping must be parallel and match the meter in- and outlet.

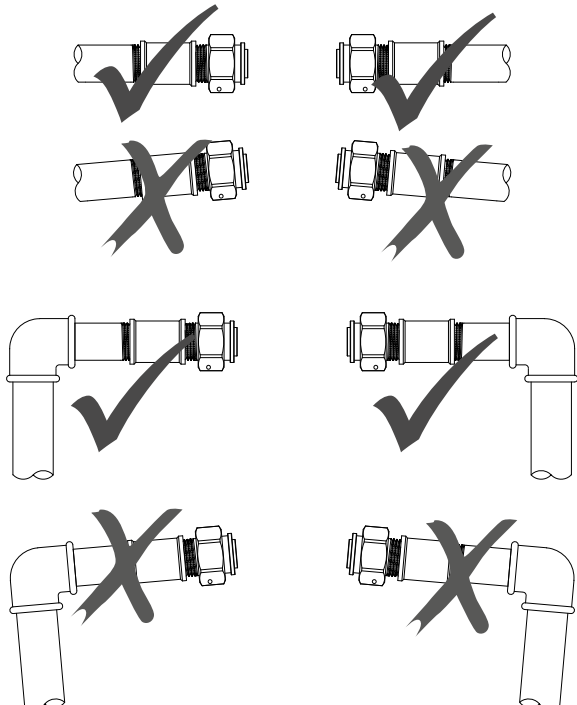

Torque, composite meters

If a pipe installation is skewed to the effect that the prescribed tightening torques would be exceeded, a meter setter or yoke should be installed.

3/4"	Max. 15 Nm
1"	Max. 30 Nm

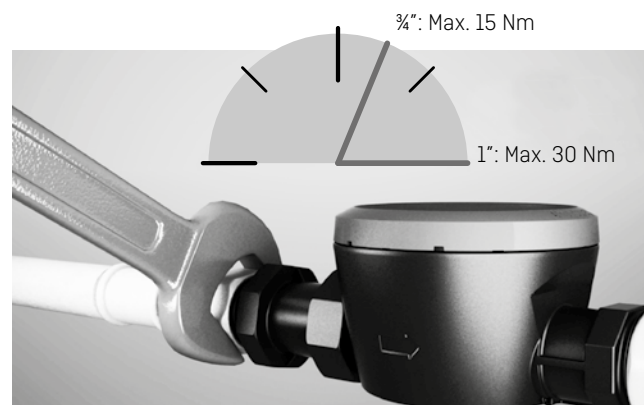

kamstrup

flowIQ® 2250
Installation guide



1 General information

Read this guide before installing the water meter.

flowIQ® 2250 is a compact electronic water meter used for water consumption measurement in the tap water supplies of homes, commercial and industrial buildings.

flowIQ® 2250 is hermetically closed, and it is, therefore, impossible to service the meter without breaking the seal. This means that all service, must be carried out by an authorized Kamstrup Service Centre.

Certain changes of configuration, however, are possible via the built-in optical eye without dismounting the meter from the installation. Further details appear in the data sheet.

1.1 Permissible operating conditions/measuring ranges

Fluid temperature:	
- 1 part body meter:	33 °F...140 °F
- 2 part body meter:	33 °F...120 °F
Pressure stage:	250 PSI
Mechanical environment:	Fixed installation with minimum vibration.

Electromagnetic environmental class:	Residential and commercial
Protection class:	IP68-rated (waterproof-submersible)
Climatic environment:	35 °F...140 °F. Condensing humidity. (indoors mounted in utility rooms and outdoors in meter pits). Installation in direct sunlight must be avoided. The meter must be protected from freezing as well.

1.2 Installation requirements

Prior to installation of flowIQ® 2250 the system should be cleaned and flushed thoroughly. Then, install the meter with matching couplings.

If an existing install, remove all traces of old gaskets and insert new gaskets in original quality. Kamstrup recommends EPDM gaskets, which are included.

Install the meter according to the flow direction indicated by an arrow on the side of the meter housing. An electrical grounding wire must be installed according to local electrical regulation and for safety reasons.

You must always use new gaskets in original quality. Following gaskets can be used:

Cold water	
¾"	2 mm EPDM or PE
1"	3 mm EPDM or PE

The flow direction is indicated by an arrow on the side of the meter case.

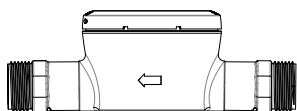

During installation it must be secured that the meter is mounted without mechanical tension in the connection pipes. The couplings must be tightened with maximum the following torque:

¾"	15 Nm
1"	30 Nm

If a tight connection cannot be obtained within these limits, the pipe installation must be corrected in order to remove strains. Alternatively a meter setter or yoke must be installed.

The piping must be in line and match the meter. Do not attempt to install the meter in a misaligned pipe system or in an opening that is too long. Jacking the piping into place with the meter will seriously damage the meter.

In a properly aligned piping system with new gaskets, you should be able to mount and tighten the couplings by hand.

After hand-tightening the coupling nuts, using an open-end wrench, tighten an extra ¼ to ½ turn on each coupling.

Mounting the meter you must make sure that the threaded length of the couplings does not prevent proper tightening of the sealing surface and that couplings with similar pressure ratings are used.

For sealing, use the sealing wire holes on the lower side of the threaded connections.

Service

When the meter has been mounted in the system neither welding nor freezing is allowed. Dismount the meter from the system before starting such work.

In order to facilitate replacement of the meter, shut off valves should be mounted on both sides of the meter.

The meter is supplied with a strainer in the inlet. Check valves must be mounted according to local regulations.



1.3 Installation angle of flowIQ® 2250

flowIQ® 2250 can be mounted at all angles and positions. Kamstrup Headquarters recommend that the display is mounted so that it is easy to read, if possible.

Thus, the meter can be mounted in a plain horizontal installation. It can be mounted vertically in an ascending pipe, it can be mounted downwards, e.g under a roof.

Mounting the meter in a downpipe, you must be aware that the display in that case will be 'upside down'.

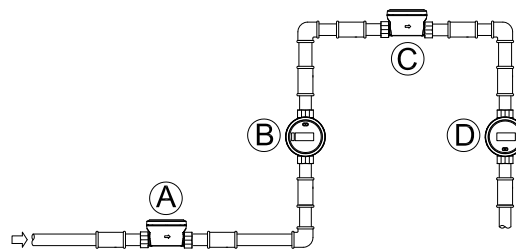

- A** Recommended water meter position.
- B** Recommended water meter position.
- C** Standard installation for pits.
- D** The meter functions optimally, but the display is 'upside down'.

1.4 Straight inlet

flowIQ® 2250 requires neither straight inlet nor straight outlet to meet applicable AWWA standards. A straight inlet section will only be necessary in case of heavy flow disturbances before the meter.

1.5 Operating pressure

In order to avoid cavitation and secure correct measurement under all circumstances the operating pressure in the pipe installation should observe the test conditions of AWWA M6 manual. The static pressure, immediately after the meter (downstream), must always be minimum 5 PSI (0.3 bar).

1.6 Info codes and display

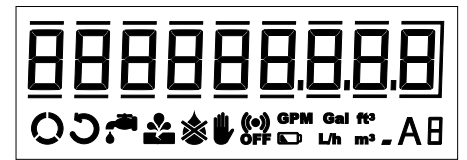

When flowIQ® 2250 leaves Kamstrup Headquarters, it has been tested and verified and the counter has been reset.

The number of gallons or cu ft are displayed by nine large digits. Bars over and under each digit are fully customizable, meaning that they can be used to indicate numbers after the decimal point or indicate if the customer is billed in e.g. tens or hundreds of gallons.

The table below describes the different info codes in the display.

Info code flashes in the display	Meaning
Flow	The three segments will switch on alternately to indicate flow in the meter
Backflow	Indication if there is reverse flow
Leak	The water has not been stagnant in the meter during the past 24 hours. This can be a sign of a leaky faucet or toilet.
Burst	The water flow has exceeded a preprogrammed limit for a minimum of 30 minutes, which is a sign of a burst pipe.
Dry	The meter is not water-filled.
Tamper	Attempt of fraud. The meter is no longer valid for billing purposes.
Radio OFF	The meter is still in transport mode with the built-in radio transmitter turned off. The transmitter turns on automatically when the first 1/4 gallon of water has run through the meter.
Flow unit	Indicates the configured flow unit.
Battery	Indication of the battery state.
Active meter indication	A small square is flashing to indicate that the meter is active.
Meter adjustment	If the meter has been dismounted, tested and the basic flow measurement has been adjusted this info code will appear.