



Kasda Networks Inc.

www.kasdanet.com

B-31, Tanlang Industry Park, Xili, Nanshan, 518055, Shenzhen, China

KW5583

User Manual

Version 1

NOTICE

This document contains proprietary information protected by copyright, and this Manual and all the accompanying hardware, software, and documentation are copyrighted. All rights are reserved. No part of this document may be photocopied or reproduced by mechanical, electronic, or other means in any form.

The manufacturer does not warrant that the hardware will work properly in all environments and applications, and makes no warranty or representation, either expressed or implied, with respect to the quality, performance, merchantability, or fitness for a particular purpose of the software or documentation. The manufacturer reserves the right to make changes to the hardware, software, and documentation without obligation to notify any person or organization of the revision or change.

All brand and product names are the trademarks of their respective owners.

Copyright 2014

All rights reserved.

Content

1.	Product Overview	1
1.1	Main Features	1
1.2	Wireless Features.....	2
1.3	Management Support	2
1.4	System Requirements	2
1.5	Environmental	2
1.6	Package.....	3
2.	Product introduction	4
2.1	Hardware Description	4
2.2	How the Extender Works.....	6
2.3	Connect a PC to the Extender with an Ethernet Cable.....	7
3.	Web-based Settings Guide	9
3.1	Extender main page configuration.....	9
3.1.1	LAN configuration	10
3.1.2	WAN configuration	12
3.1.3	Wireless configuration	14
3.1.4	Administration configuration	17
3.2	Connect the Extender to an Existing Network.....	21
3.2.1	Connect the Extender to an Existing Network	21
3.2.2	Using WPS	23

1. Product Overview

Thank you for choosing our product. The KASDA Universal WIFI Range Extender KW5583 effectively doubles the operating distance of your entire wireless network and conveniently avoids additional need for power cables or device clutter on your office desk or home theater. KW5583 extends your wireless network to include the area outside the range of your existing wireless router by overcoming obstacles and enhancing overall network signal quality, giving you the freedom to roam anywhere in the house and access Internet without worrying about coverage. The product was specifically designed to be plugged into an electrical outlet, and blends in nicely with any surrounding. It is compatible with wireless b/g/n routers, gateways and Internet service provider devices.

With 300Mbps wireless N speeds, KW5583 turns your ‘dead zones’ into connected zones, helping you keep mobile devices, media players and computers connected to Wi-Fi with a reliable connection.

1.1 Main Features

- ✚ Extend Internet access throughout your home for wireless devices like iPads , iPods , laptops, smart phones, game consoles and TVs.
- ✚ Keep your current equipment and improve coverage to eliminate wireless “dead zones”
- ✚ Very easy to use.Sets up in minutes, no need to insert a CD or plug in Ethernet cables
- ✚ Push ‘N’ Connect— Push ‘N’ Connect using Wi-Fi Protected Setup (WPS) connects computers and/or routers to the Extender quickly and securely
- ✚ Works with any wireless b/g/n router or gateway from KASDA and other brands
- ✚ Works with all security standards including WPA-PSK, WPA2-PSK, mixed mode and WEP
- ✚ Ethernet port allows the Extender to function as a bridge to connect to home theater devices

1.2 Wireless Features

- ✚ Fully IEEE 802.11b /g /n compatible.
- ✚ Wireless data rate up to 300 Mbps
- ✚ Operating in the unlicensed 2.4 GHz ISM band
- ✚ Easy wireless security encryption at a push of the WPS button
- ✚ Supports 64/128 bits WEP, WPA, WPA2, WPA/WPA2-PSK, 802.1x

1.3 Management Support

- ✚ Web Based GUI
- ✚ Upgrade or update via FTP/HTTP
- ✚ Command Line Interface via Telnet
- ✚ Firmware upgrade-able for future feature enhancement

1.4 System Requirements

- ✚ 802.11 b/g/n 2.4 GHz wireless router or gateway
- ✚ 802.11 b/g/n 2.4 GHz wireless adapter or Ethernet adapter and cable for each computer
- ✚ Microsoft® Windows 7, Windows 8, Vista®, XP®, 2000, Mac OS®, UNIX®, or Linux®
- ✚ Microsoft® Internet Explorer® 5.0, Firefox® 2.0 or Safari® 1.4 or higher

1.5 Environmental

- ✚ Operating temperature: 32 ° to 140 °F (0 ° to 40 °C)
- ✚ Operating Humidity: 10% ~ 90% RH non-condensing;
- ✚ Storage Humidity: 5% ~ 90% RH non-condensing.

1.6 Package

 KW5583 ×1



 CD ×1

2. Product introduction

2.1 Hardware Description

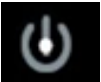

The LEDs on the front panel show how the Extender is working:

LED	Color	Function
 PWR	Green	Off: Power Not Supplied On: Power Supplied
 LAN	Green	On: LAN link established and active via LAN port Blinking: ADSL data activity occurs Off: No LAN link via LAN port
 WIFI	Green	On: The wireless module is ready and idle Blinking: Data transmitting or receiving over WLAN Off: The wireless function is off

 <p data-bbox="316 434 384 465">WPS</p>	<p data-bbox="523 300 600 331">Green</p>	<p data-bbox="655 315 1273 351">On: There is wireless security (WPA or WPA2).</p> <p data-bbox="655 369 1273 405">Blinking: Trying to establish a WPS connection</p> <p data-bbox="655 423 1273 459">Off: WPS function is off or no WPS connection</p>
--	--	--



WPS button: Press the WPS button to wirelessly connect the Extender to your router or wireless adapter.

The side panel has the following feature:

Reset: Factory Reset button. To use this button, stick a paper clip into the reset hole and hold it until the Status LED flashes.

The down panel has the following feature:



Ethernet Port. You can use this for a wired connection to a computer or other device as described in the User Manual.

☞ **Note:** When using extender, for best performance, position antennas pointing up.

2.2 How the Extender Works

The Extender works like a bridge between a wireless router and a computer or wireless device outside the wireless router's range. To do this, the Extender has two main jobs:

1. The Extender connects to a wireless network that is up and running. When the Extender connects wirelessly to a network, it acts as a network client. This is similar to how a computer connects to a network.
2. The Extender acts as an access point for computers.

In its role as an access point, the Extender performs tasks that wireless routers do, such as broadcasting its network name (SSID).



Range Extender in a home

When to Use Your Extender?

KASDA recommends that you connect to the Extender only when your home network connection is poor. Because data traffic routed through the Extender is inherently slower than traffic routed directly from the network, the computer should stay on the network if the connection is good enough. KASDA recommends that you connect through the Extender network only when the computer is in a “dead zone” where connection from the network is very poor or non-existent.

The ideal location to place the Extender is half-way between your wireless router and your computer.

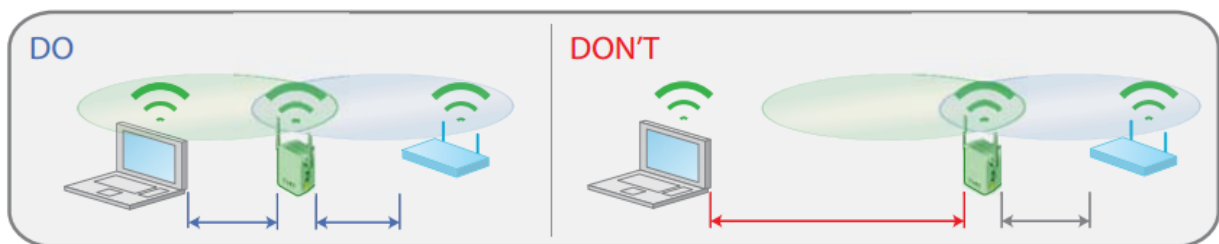

Range extender location

The best connection is established when there is a clear line of sight between the Extender and the wireless router and also a clear line of sight between the Extender and the computer you are using. If this straight path is blocked by a thick wall or other materials, move the Extender to a different location half-way between the computer and the router. If there is no power outlet nearby, or you prefer to place the Extender elsewhere, move the Extender closer to the computer.

2.3 Connect a PC to the Extender with an Ethernet Cable

Usually, you connect to the Extender wirelessly, but you can use its LAN port to connect a wired device such as an Ethernet-enabled gaming console, printer, or PC.

1. Connect your computer to the Extender with an Ethernet cable.
2. Plug the Extender into an electrical outlet.
3. Log in as described in the following section.

☞ **CAUTION:**

Do not use Ethernet cable to connect the Extender to a router. If you do so, the Extender does not work because it is designed to use only a wireless connection to the router.

If you have trouble connecting

- ✧ Make sure you use a computer that occupies the same subnet with the Extender. The simplest way to do this for many users will be to use DHCP server that is enabled by default on the Extender.
 - ✧ If you start your computer, connect the Ethernet cable to the Extender, and launch your browser quickly, the computer might still need a couple of minutes to recognize the Ethernet LAN connection before you can connect.
 - ✧ Make sure that your Ethernet cable is securely connected to the Extender and the computer, and that the Extender LAN LED is on. If the LED is not lit reconnect the Ethernet cable, and relaunch your Internet browser.
1. On your computer, launch an Internet browser such as Mozilla Firefox or Microsoft Internet Explorer.
 2. In the address field of your browser, enter **192.168.0.1**. You are prompted to enter a user name and password. **They are: admin & admin**. Now you can configuration your extender.

You can log in to the Extender to use the menu selections to view or change the extender's settings.

3. Web-based Settings Guide

To change settings, connect the Extender to your computer and use your Internet browser to go to <http://192.168.0.1> described in Connect a PC to the Extender with an Ethernet Cable.

3.1 Extender main page configuration

When using <http://192.168.0.1> to log on to the setting pages. Enter username “admin” and password “admin”, then click “OK”.

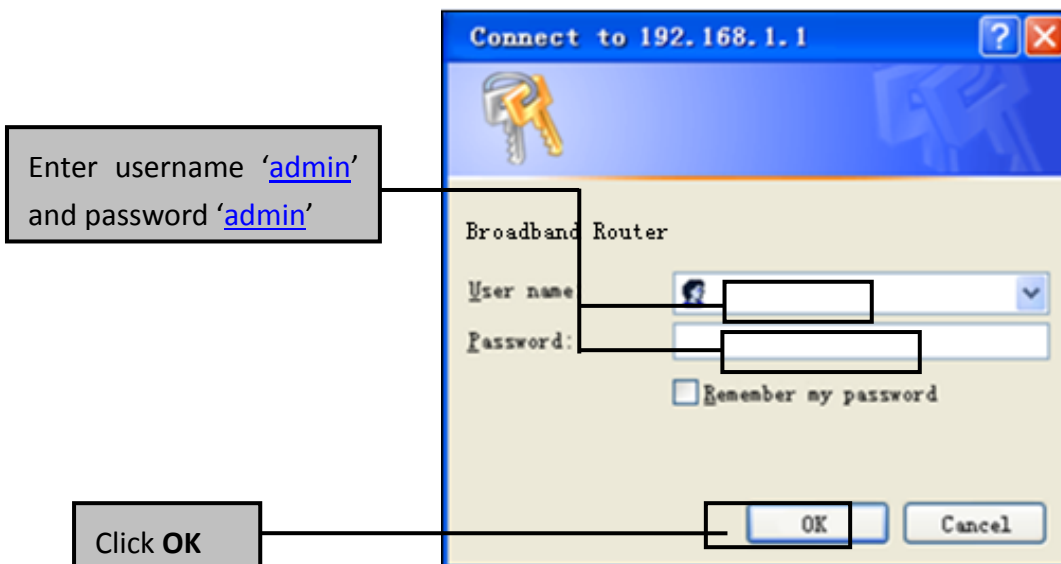

You will see the following page. The Status page displays the Router's current status and wan configuration.

This page show the router local, Ethernet network.

If you are using the Router as a DHCP server, that will be displayed here.

The screenshot shows the KASDA router's status page. The top navigation bar includes 'Basic', 'Quick Setup', and 'English'. The main menu has 'Status', 'Lan', 'Wan', 'Wireless', and 'Administration'. The 'Status' page is active, displaying 'Router Information' and 'Local Network' sections. A 'Help' sidebar is also visible.

Router Information	
Router	
Router Model:	KW5583
Firmware Version:	V1.3.7 build Jan 15 2015
Current Time:	Thu, 01 Jan 1970 00:00:43 -0800
Internet MAC Address:	00:0E:F4:FD:02:F1
Internet IPv4	
Connection Type:	dhcp
Connection Status:	Disconnected
Internet IP Address:	0.0.0.0
Default Gateway:	0.0.0.0
DNS:	
Local Network	
LAN Status	
MAC Address:	00:0E:F4:FD:02:F0
IP Address:	192.168.0.1
Subnet Mask:	255.255.255.0

Help

The Status page displays the Router's current status and wan configuration.

This page show the router local, Ethernet network.

If you are using the Router as a DHCP server, that will be displayed here.

These are the current settings or information for Wireless.

You can configure them in the Wireless -> Basic Settings page.

These are the current settings or information for Wireless. You can configure them in the Wireless -> Basic Settings page.

The screenshot shows the 'Wireless' status page. It displays the following information:

Wireless	
Wireless Status	
MAC Address:	00:0E:F4:FD:02:F1
Network Name (SSID):	KA200-Robin_ext
Security:	Disabled
SSID Broadcast:	Enabled

3.1.1 LAN configuration

You can configure the IP parameters of LAN on this page.

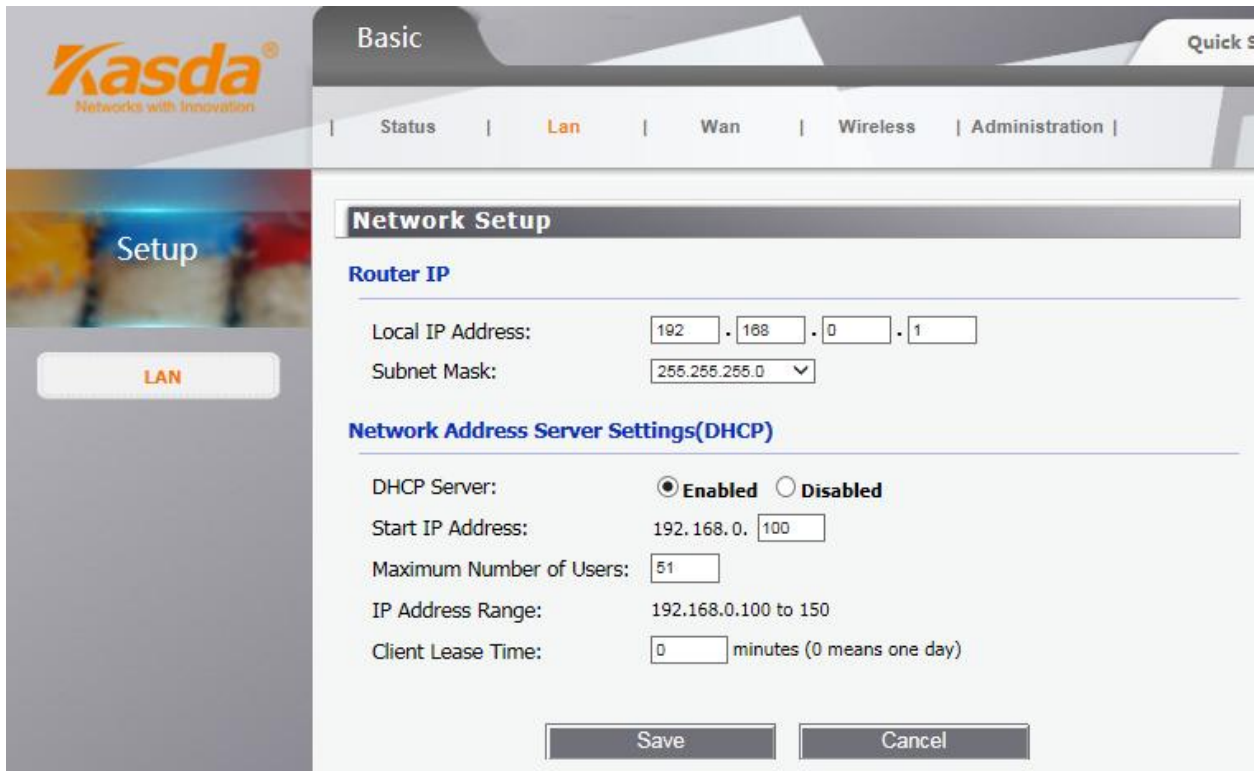

❖ Router IP

Local IP Address / Subnet Mask: This is the router IP Address and Subnet Mask as seen on the internal LAN. The default value is 192.168.0.1 for IP Address and 255.255.255.0 for Subnet Mask.

❖ Network Address Server setting(DHCP)

DHCP Server – Keep the default, Enable, to enable the router's DHCP server option. If you already have a DHCP server on your network or you do not want a DHCP server, then select Disable.

Start IP Address: Specify an IP address for the DHCP Server to start with when assigning IP addresses. 192.168.0.100 is the default start address.

Maximum number of Users – Enter the maximum number of PCs that you want the DHCP server to assign IP addresses to. The absolute maximum is 253, possible if 192.168.1.2 is your starting IP address.

Client Lease Time – Enter the length of time, in minutes, that a DHCP client will be allowed to use a dynamic IP address. The default is 0 minutes, which means one day. After this time is up, the client will be automatically assigned a new dynamic IP address, or the lease will be renewed.

Note:

- 1) If you change the IP Address of LAN, you must use the new IP Address to log in the extender.
- 2) If the new LAN IP Address you set is not in the same subnet, the IP Address pool of the DHCP server will change accordingly at the same time.

3.1.2 WAN configuration

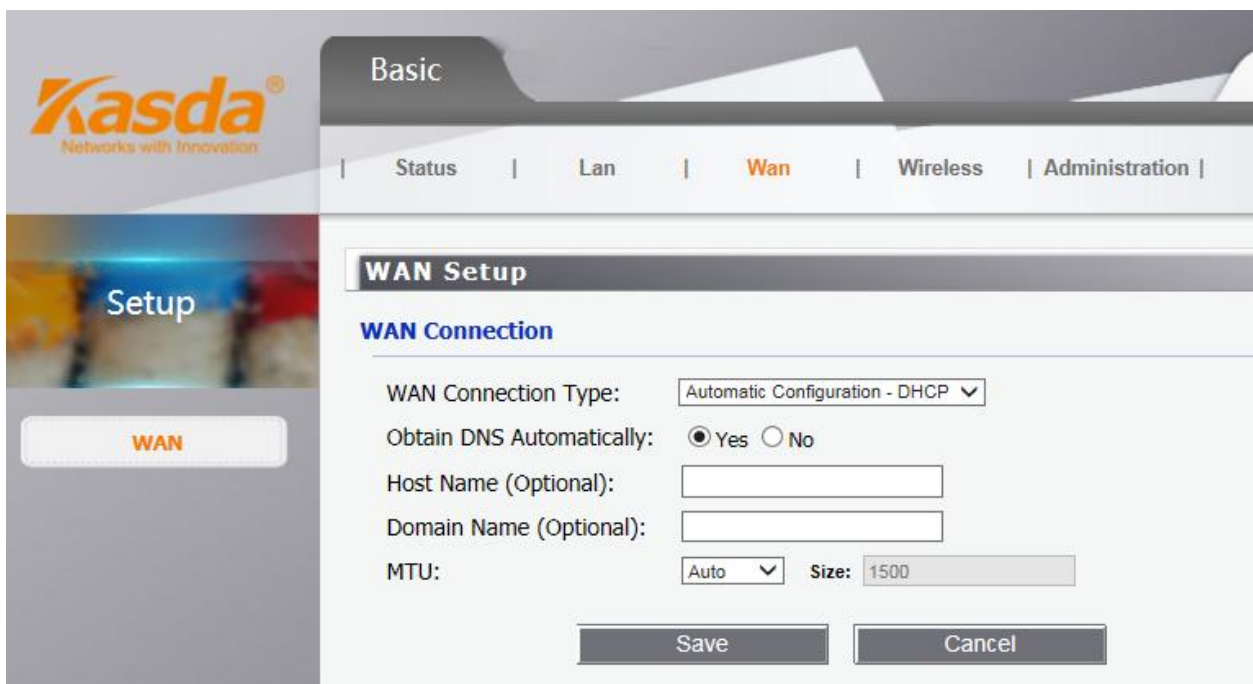

The screenshot displays the KASDA network management interface. The top navigation bar includes 'Basic', 'Status', 'Lan', 'Wan', 'Wireless', and 'Administration'. The 'Wan' tab is selected. Below the navigation bar, the 'WAN Setup' section is visible. Under 'WAN Connection', the following settings are shown: 'WAN Connection Type' is set to 'Automatic Configuration - DHCP'; 'Obtain DNS Automatically' is set to 'Yes'; 'Host Name (Optional)' and 'Domain Name (Optional)' are empty text boxes; 'MTU' is set to 'Auto' with a 'Size' of '1500'. At the bottom of the configuration area, there are 'Save' and 'Cancel' buttons.

The router supports several connection types to WAN (wide area network). These types are selected from the dropdown menu beside WAN Connection Type. The setting fields differ depending on the connection type you selected.

✧ WAN Connection Type

(1) Automatic Configuration – DHCP

If you connect using a dynamic IP address or cable modem, keep the default: Automatic Configuration - DHCP.

WAN Connection

WAN Connection Type: Automatic Configuration - DHCP

Obtain DNS Automatically: Yes No

Host Name (Optional):

Domain Name (Optional):

MTU: Auto Size: 1500

Save Cancel

Host Name (Optional) – Enter a host name for the extender, if required by your ISP.

Domain Name (Optional) – Enter a domain name for the extender, if required by your ISP.

MTU – MTU is the Maximum Transmission Unit. It specifies the largest packet size permitted for Internet transmission. Keep the default setting, Auto, to have the router select the best MTU for your Internet connection. To specify a MTU size, select Manual, and enter the value desired (default is 1400). You should leave this value in the 1200 to 1500 range.

(2) Static IP .

To use a fixed IP address to connect to the Internet, select Static IP.

WAN Setup

WAN Connection

WAN Connection Type: Static IP

Internet IP Address: 0 . 0 . 0 . 0

Subnet Mask: 0 . 0 . 0 . 0

Default Gateway: 0 . 0 . 0 . 0

DNS 1: 0 . 0 . 0 . 0

DNS 2 (Optional): 0 . 0 . 0 . 0

DNS 3 (Optional): 0 . 0 . 0 . 0

Host Name (Optional):

Domain Name (Optional):

MTU: Auto Size: 1500

Save Cancel

Internet IP Address – Enter the IP address provided by your ISP.

Subnet Mask – Enter the subnet mask provided by your ISP.

Default Gateway – Enter the gateway IP address provided by your ISP.

DNS 1-3 – Enter the DNS (Domain Name System) server IP address(es) provided by your ISP.

3.1.3 Wireless configuration

✧ Wireless basic settings

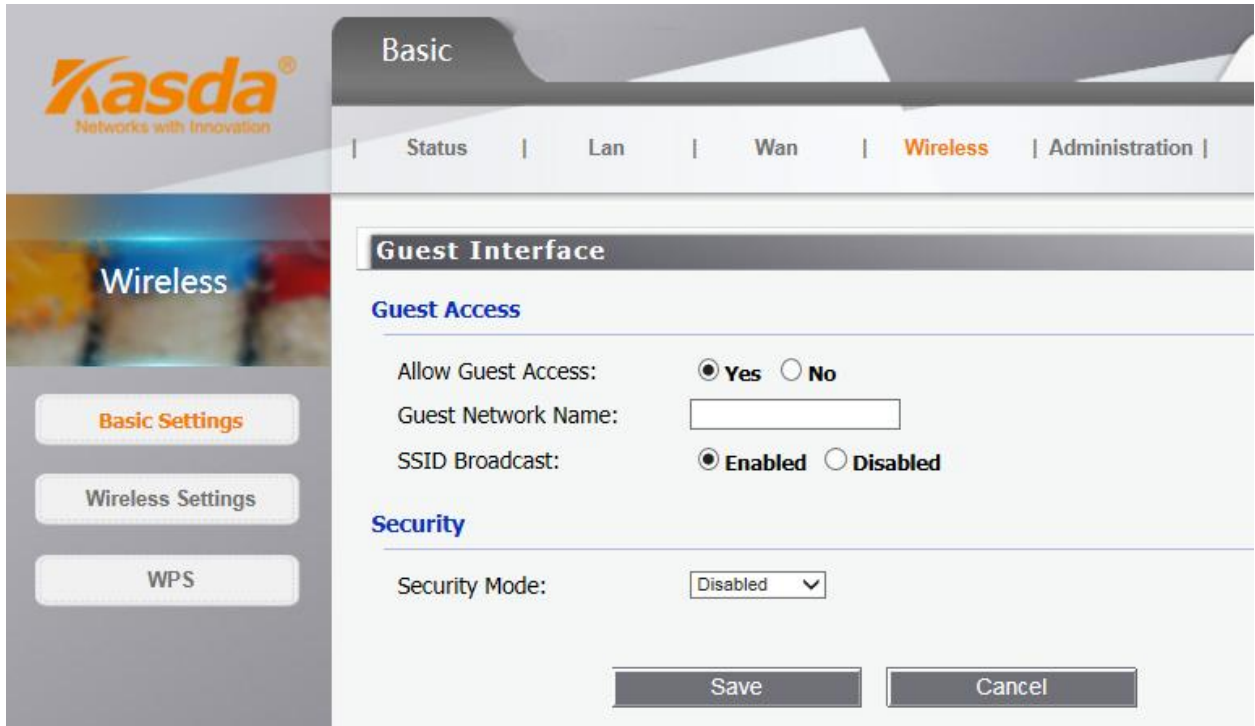

Use the Guest Access feature to provide guests visiting your home with Internet access only. The guest network is a wireless network separate from your local network.

- **Allow Guest Access** – To allow Internet access through a guest network, select yes.
- **Guest Network Name** – The name of the guest network is displayed.
- **SSID Broadcast** – When wireless devices survey the local area for wireless networks to associate with, they will detect the SSID (wireless network name) broadcast by the Router. To broadcast the SSID of the guest network, keep the default, Enabled.

You can select one of the following security options:

- **Disabled** – The wireless security function can be enabled or disabled. If disabled, the

wireless stations will be able to connect the Router without encryption. It is recommended strongly that you choose one of following options to enable security.

- WEP – Select 802.11 WEP security.
- WPA/WPA2 - Personal – Select WPA based on pre-shared passphrase.
- WPA/WPA2 - Enterprise – Select WPA based on Radius Server.

Each security option has its own settings as described follows.

✧ WEP

Select a level of WEP encryption.

- Passphrase – Enter a passphrase to automatically generate WEP keys. Then click Generate.
- Key 1 – If you did not enter a passphrase, enter the WEP key(s) manually.

✧ WPA/WPA2

Version - You can select one of following versions,

- WPA – Wi-Fi Protected Access.
- WPA2 – WPA version 2.
- RADIUS Server – Enter the IP address of the RADIUS server.
- RADIUS Port – Enter the port number of the RADIUS server. The default is 1812.
- Shared Key – Enter the key shared between the Router and the server.

✧ WPA-PSK/WPA2-PSK

Version - You can select one of following versions,

- WPA-PSK – Pre-shared key of WPA.
- WPA2-PSK – Pre-shared key of WPA2.

PSK Password –You can enter ASCII or Hexadecimal characters. For Hexadecimal, the length should be between 8 and 64 characters; for ASCII, the length should be between 8 and 63 characters.

✧ Wireless settings

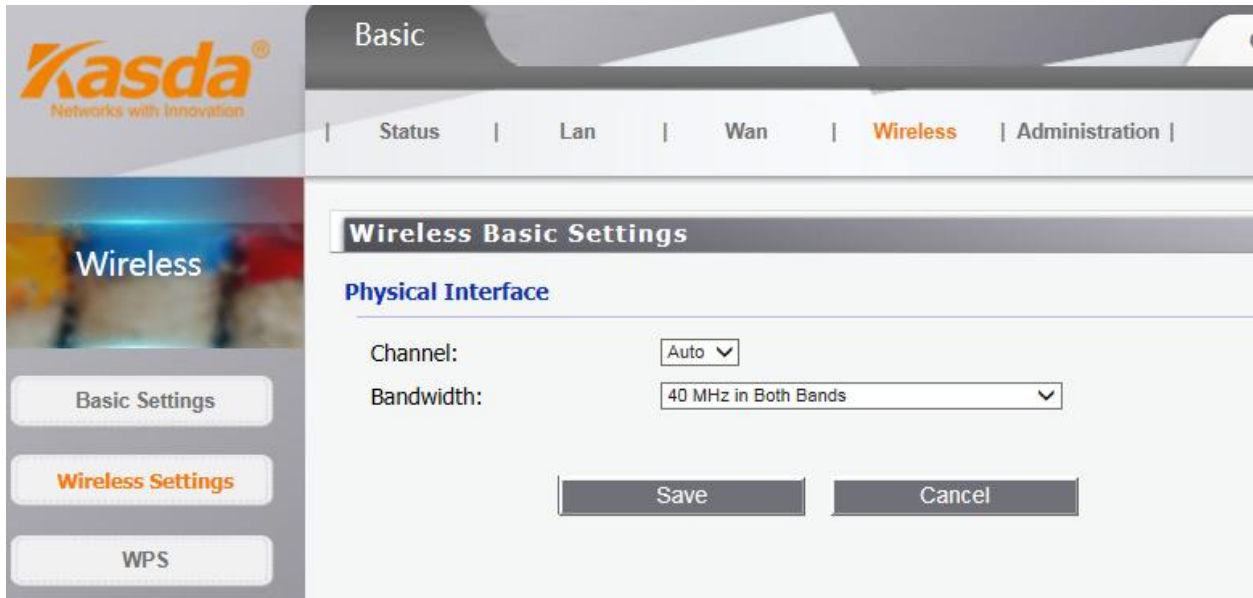

- **Channel** – This field determines which operating frequency will be used. It is not necessary to change the wireless channel unless you notice interference problems with another nearby access point. If you select auto, then AP will choose the best channel automatically.

- **Bandwidth** – The bandwidth of the wireless channel.

✧ WPS configuration

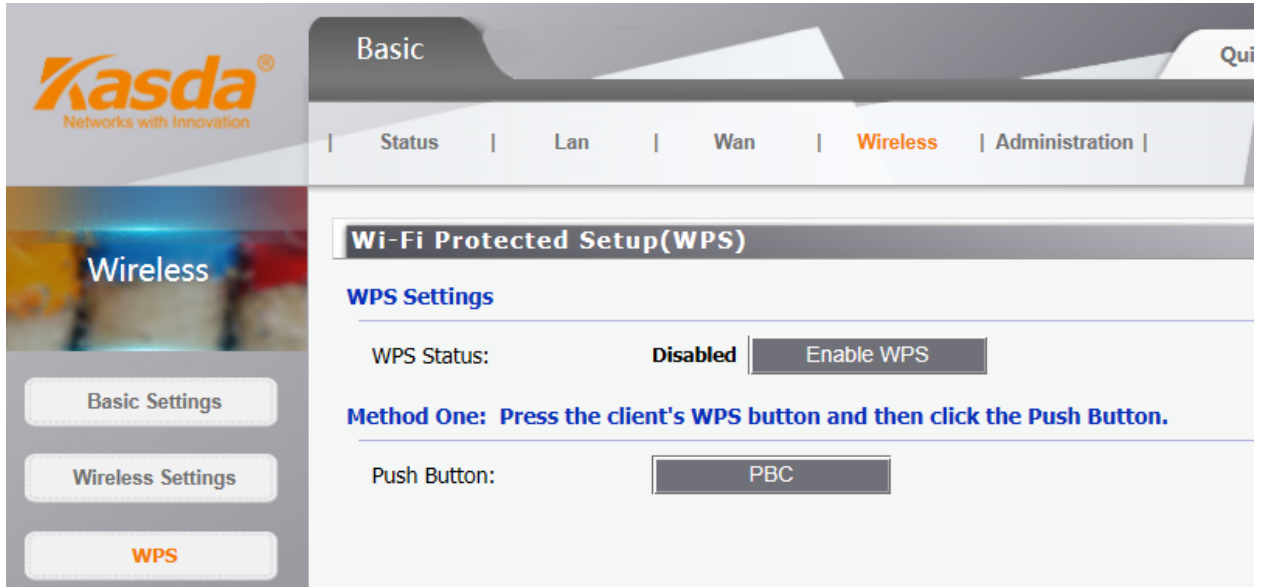

WPS function will help you add a new device to the network quickly. If the new device supports Wi-Fi Protected Setup and is equipped with a configuration button, you can add it to the network by pressing the configuration button on the device and then press the button on the Router within two minutes. The status LED on the Router will light blue for five minutes if the device has been successfully added to the network. If the new device supports Wi-Fi Protected Setup and the connection way using PIN, you can add it to the network by entering the Router's PIN.

- WPS Status – Enable or disable the WPS function here.
- Push Button – This button's function is same to the physical button on the router.

3.1.4 Administration configuration

✧ Time setting

This page allows you to set the time manually or to configure automatic time synchronization. The Router can automatically update the time from an NTP server via the Internet.

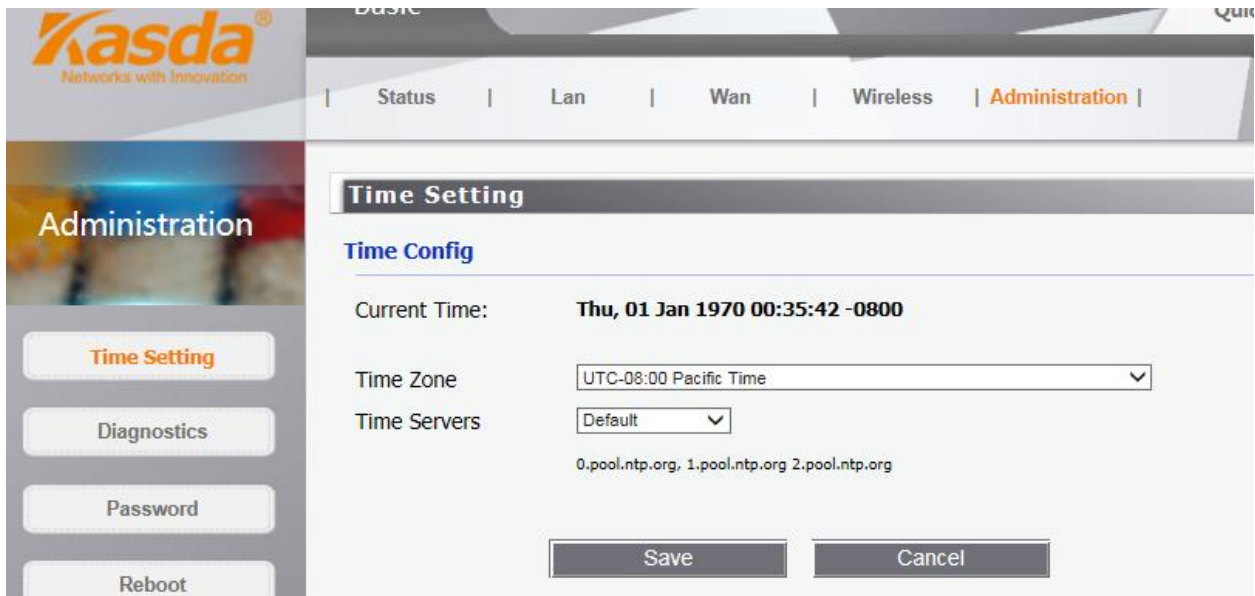

Time Zone - Select your local time zone from this pull-down list.

Time Servers - Select the time servers. You can choose the place where you are. Or select **Custom** to configure the servers by yourself.

Note: After you have made your changes, Click **Save** to apply the changes.

✧ Password:

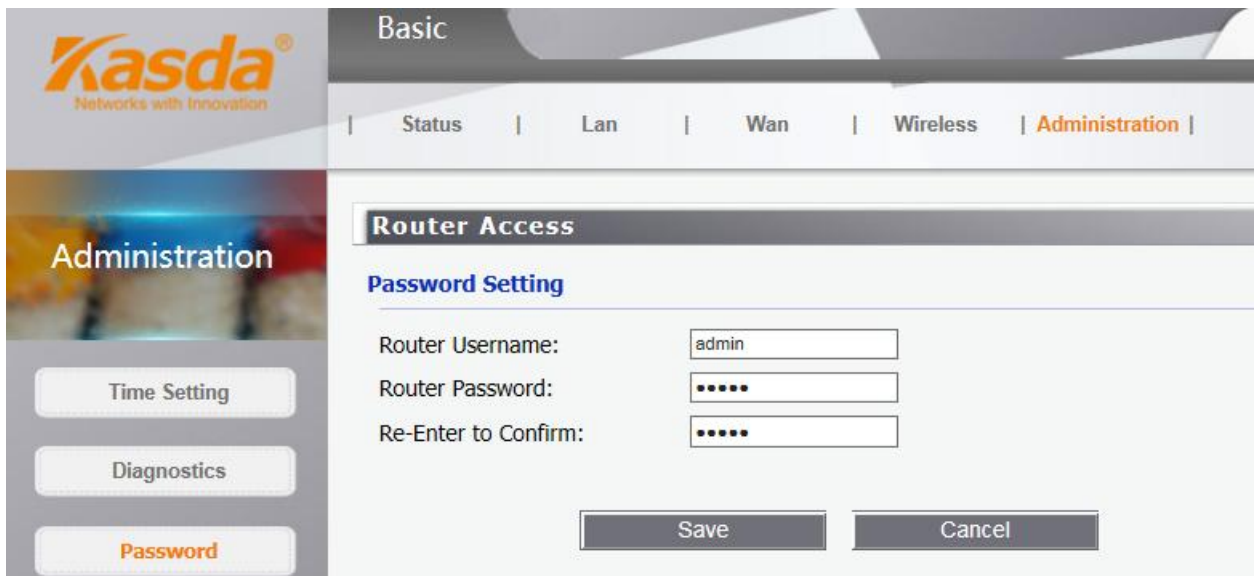

It is strongly recommended that you change the factory default user name and password of the Router. All users who try to access the Router's web-based utility will be prompted for the

Router's user name and password.

✧ Backup/restore/reset

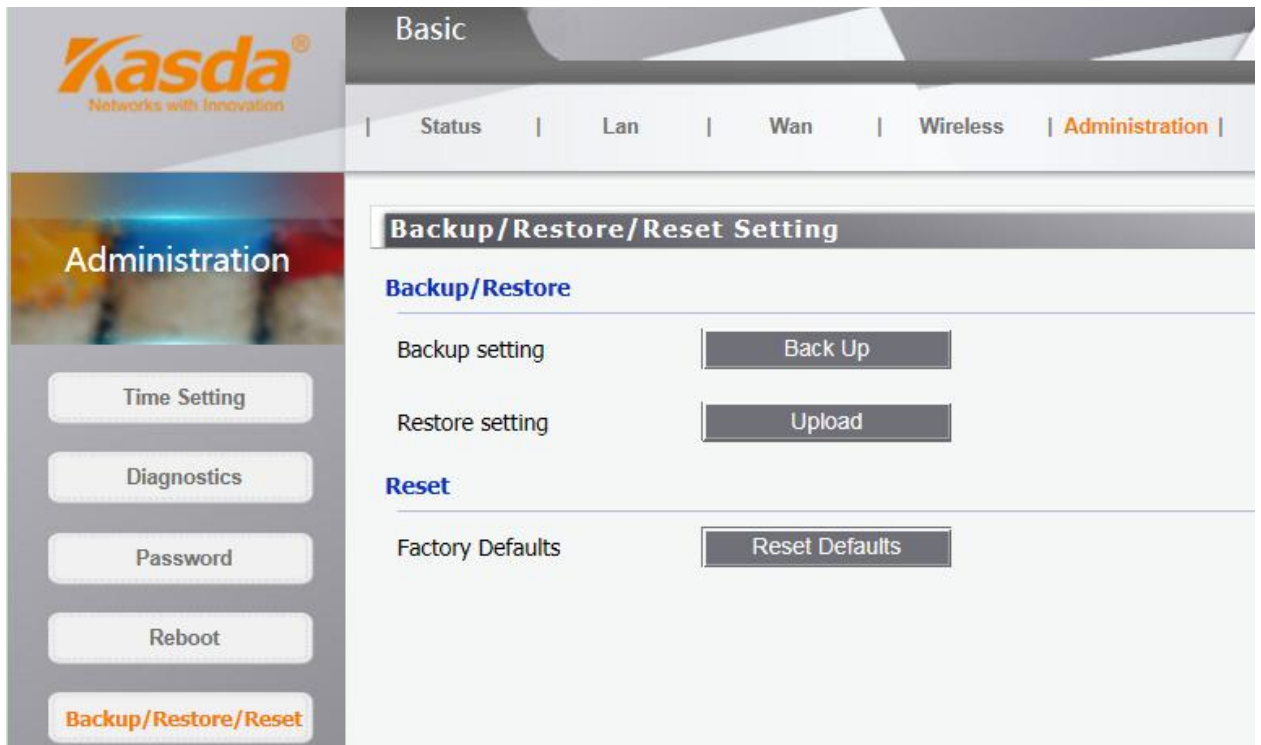

Click the **Backup** button to save all configuration settings to your local computer as a file. Click the **Browse** button to find the configuration file which you want to restore.

Click the **Upload** button to update the configuration with the file whose path is the one you have input or selected in the blank.

Click the **Reset Defaults** button to reset all configuration settings to their default values.

The default User Name: admin

The default Password: admin

The default Subnet Mask: 255.255.255.0

Factory settings		
Wireless	Wireless communication	enabled
	Wireless Network name(SSID)	
	Security	disabled
	Transmission speed	Auto ¹
	Operating mode	802.11n, 802.11g, 802.11b
	Data rate	Up to 300Mbps

You can also press and hold the Reset button on the side panel for 6 seconds. The Extender resets, and returns to its factory settings.

1. Maximum wireless signal rate (IEEE Standard 802.11). Actual throughput will vary. Network conditions and environmental factors, including volume of network traffic, building materials and construction, and network overhead, lower actual data throughput rate.

Note: All changed settings will be lost when defaults are restored.

✧ Firmware update

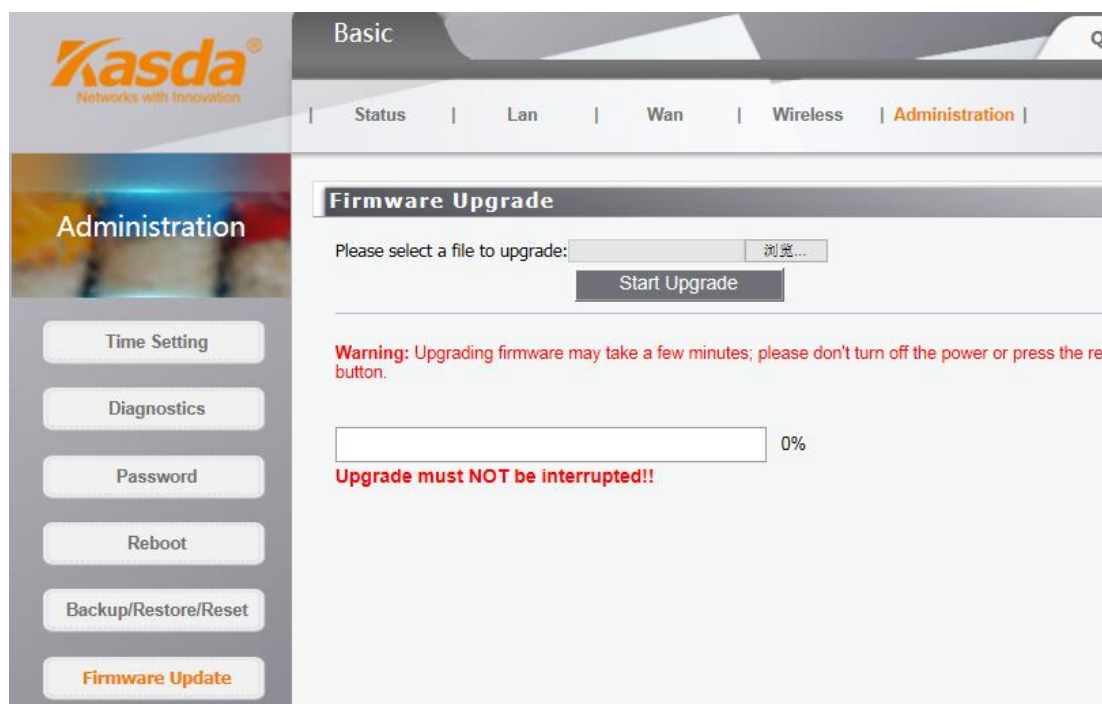

Click **Browse/Choose** and select the firmware upgrade file. Then click **Start Upgrade**.

Warning: Upgrading firmware may take a few minutes; please don't turn off the power or press the reset button.

Upgrade must not be interrupted!!

3.2 Connect the Extender to an Existing Network

3.2.1 Connect the Extender to an Existing Network

Here you can use quick setup page to connect the Extender to an Existing Network. This page will guide you through the process step by step configuration wireless extensions.

Step 1: Click the start button to search for available near the SSID.

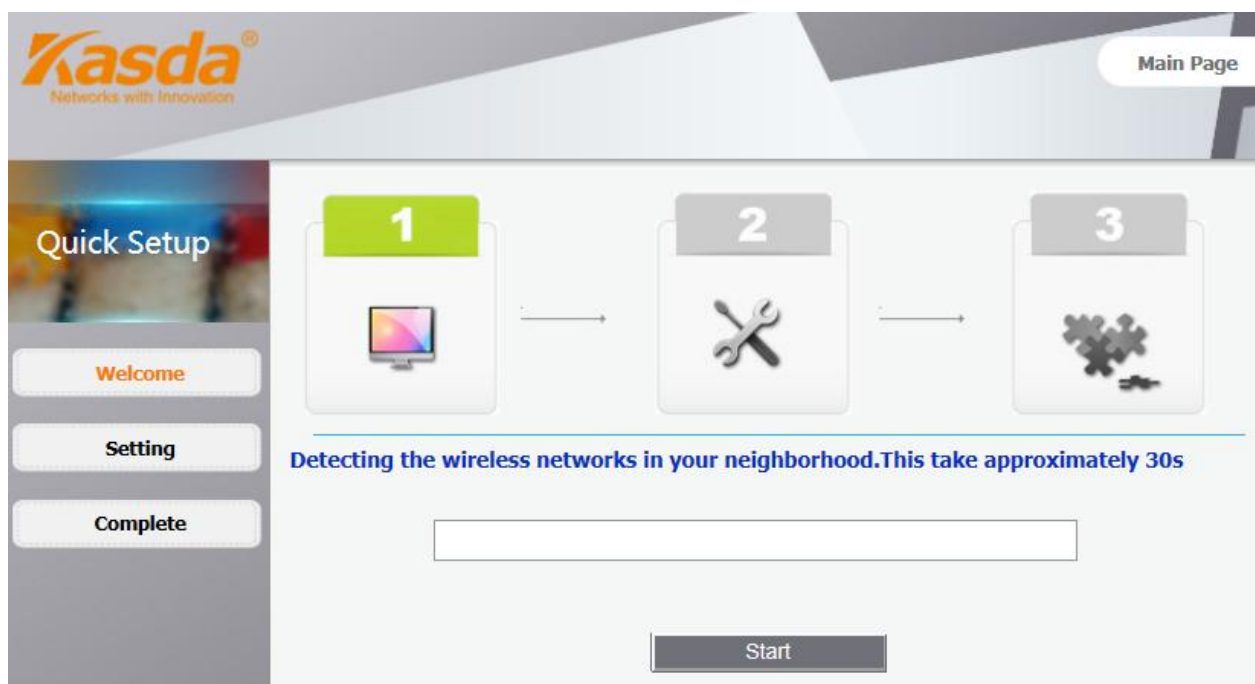

Step 2: After completion of the progress bar will automatically jump to the next screen, please wait around 30s.

Step 3: Select the SSID in the table you need as the primary SSID. Its security mode will be filled in the **Security Mode** list, please input password that you have selected. And then click next.

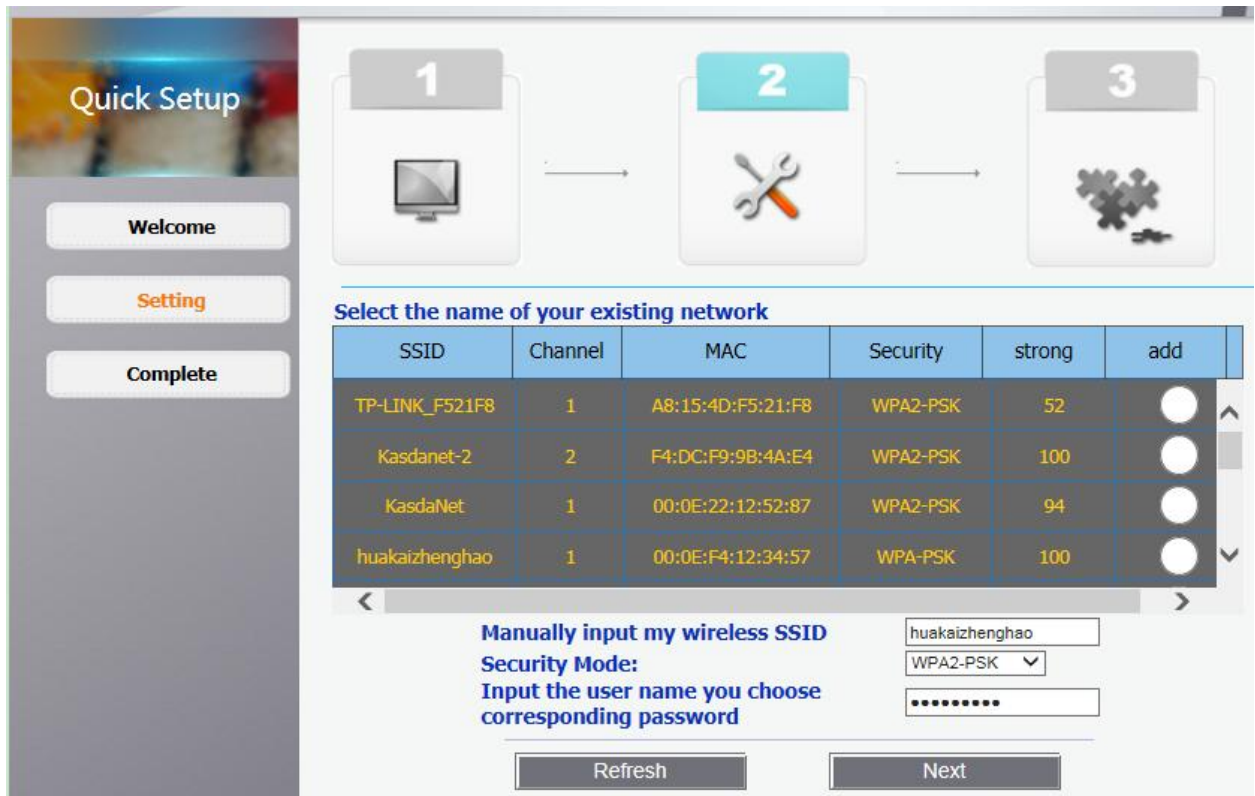

Step 4: In the second SSID corresponding box enter your SSID. In the corresponding box password enter the password you set. Click Apply button to complete the setting.



Step 5: You have completed all set! It is to set up the connection for you, please wait for 1 to 2 minutes. Set up automatically jump to the main interface as below if the connection is successful.



3.2.2 Using WPS

WPS (Wi-Fi Protected Setup) lets you connect a wireless device to the Extender's network without entering the wireless network passphrase or key. Instead, you use a WPS button or enter a PIN to connect. WPS supports WPA and WPA2 wireless security. If your Extender network is open (no wireless security is set), then connecting with WPS automatically sets WPA2 + WPA wireless security on the Extender network.

To use the Extender WPS button to connect:

1. Locate the WPS button on the side of the Extender.
2. Press the Extender's WPS button for 2 minutes, the Extender attempts to add a wireless client (a wireless device) to its wireless network.
3. Within 2 minutes, press the WPS button on your wireless device, or follow the WPS instructions that came with your wireless device. Your wireless device is now connected to the Extender.

RF Exposure Information and Statement

This equipment complies with FCC/IC radiation exposure limits set forth for an uncontrolled environment. This equipment should be installed and operated with minimum distance of 20 cm between the radiator and your body. This transmitter must not be co-located or operating in conjunction with any other antenna or transmitter.

This device complies with part 15 of the FCC rules and Industry Canada licence-exempt RSS standard(s). Operation is subject to the following two conditions: (1) this device may not cause harmful interference, and (2) this device must accept any interference received, including interference that may cause undesired operation.

Le présent appareil est conforme aux CNR d'Industrie Canada applicables aux appareils radio exempts de licence. L'exploitation est autorisée aux deux conditions suivantes :

- (1) l'appareil ne doit pas produire de brouillage, et
- (2) l'utilisateur de l'appareil doit accepter tout brouillage radioélectrique subi, même si le brouillage est susceptible d'en compromettre le fonctionnement.

NOTE: The manufacturer is not responsible for any radio or TV interference caused by unauthorized modifications to this equipment. Such modifications could void the user's authority to operate the equipment.

NOTE: This equipment has been tested and found to comply with the limits for a Class B digital device, pursuant to part 15 of the FCC Rules. These limits are designed to provide reasonable protection against harmful interference in a residential installation. This equipment generates uses and can radiate radio frequency energy and, if not installed and used in accordance with the instructions, may cause harmful interference to radio communications. However, there is no guarantee that interference will not occur in a particular installation. If this equipment does cause harmful interference to radio or television reception, which can be determined by turning the equipment off and on, the user is encouraged to try to correct the interference by one or more of the following measures:

- Reorient or relocate the receiving antenna.
- Increase the separation between the equipment and receiver.
- Connect the equipment into an outlet on a circuit different from that to which the receiver is connected.
- Consult the dealer or an experienced radio/TV technician for help
- This device and its antenna(s) must not be co-located or operating in conjunction with any other antenna or transmitter.

(i) Ce dispositif doit être installé et exploité dans une enceinte entièrement fermée afin de prévenir les rayonnements RF qui pourraient autrement perturber la navigation aérienne. L'installation doit être effectuée par des installateurs qualifiés, en pleine conformité avec les instructions du fabricant.

(ii) Ce dispositif ne peut être exploité qu'en régime de non-brouillage et de non-protection, c'est-à-dire que l'utilisateur doit accepter que des radars de haute puissance de la même bande de fréquences puissent brouiller ce dispositif ou même l'endommager. D'autre part, les capteurs de niveau à propos desquels il est démontré qu'ils perturbent une exploitation autorisée par licence de fonctionnement principal doivent être enlevés aux frais de leur utilisateur.