

SharpEye™ SCV & SxV X-Band Radome Radar

INSTALLATION, TERMINATION & MAINTENANCE HANDBOOK



KH-1650-CA
Issue 1

SITUATIONAL AWARENESS, THE WORLD OVER



SharpEye™ SCV & SxV X-Band Radome Radar
Chapter 1: Contents

DOCUMENT HISTORY

Issue number	Release date	Details
1	13 th July 2017	<ul style="list-style-type: none">• Handbook generated from Issue 4 of KH-1650• French translations of the Health & Safety section added.

AMENDMENT RECORD

When an amendment is incorporated into this handbook, the details should be recorded below.

Amendment number	Date inserted (DD-MM-YYYY)	Initials	Details

© Copyright Kelvin Hughes Limited (2017) all rights reserved

No parts of this publication may be reproduced, transmitted, transcribed, translated or stored in any form or by any means without the written permission of Kelvin Hughes Limited

Technical details contained in this publication are subject to change without notice

Where translated, the original English version of this document will remain the definitive document and should be referred to in any situation of doubt, confusion or conflict

When planning any aspect of installation, commissioning, operation or maintenance of the system(s) described in this handbook, it is the responsibility of the individual carrying out the required task to ensure they are working from the latest issue/ revision of the document

Printed copies of this handbook are not maintained

1 Contents

1	Contents	3
2	Health and safety (Recommandations sanitaires et de sécurité)	5
3	Introduction	11
3.1	System overview	11
3.2	Display interfacing	12
3.3	Typical systems	12
4	Positioning of radar equipment	15
5	Preparation for installation	19
5.1	Pre-Installation requirements	19
5.2	Fitting kits	20
5.3	Location	21
5.4	Lifting considerations	21
6	Mechanical installation	23
6.1	Mounting platform	23
6.2	Anti-vibration mount/ Cable bracket assembly	24
6.3	Installation	27
6.4	DIMENSIONS: SCV	28
6.5	DIMENSIONS: SxV	29
7	Termination	31
7.1	Cabling and termination	31
7.2	DC input	33
7.3	LAN input	35
7.4	Ground/ Earth cable	36
7.5	CONNECTION DIAGRAM	38
8	Commissioning	39
8.1	Overview	39
8.2	Commission web page	40
8.3	Compass Settings	41
8.4	Blind sector, heading line offset record	42
9	Completion of installation	43
9.1	Installation checks	43
9.2	Warranty	44
10	Operator instructions	45
10.1	Switch ON and OFF	45
10.2	Control	45
10.3	Elevation beamwidth	45
10.4	Performance monitoring	45
10.5	Operational states	46

SharpEye™ SCV & SxV X-Band Radome Radar
Chapter 1: Contents

11	Planned maintenance	49
12	Corrective maintenance	53
12.1	System reset	53
12.2	Repair and return	53
12.3	Troubleshooting	54
13	Specifications	55
13.1	Mechanical specifications	55
13.2	Environmental specifications	55
13.3	Transceiver specifications	56
13.4	Approvals	57
14	Contact details.....	59

SharpEye™ SCV & SxV X-Band Radome Radar
Chapter 2: Health and safety (Recommandations sanitaires et de sécurité)

2 Health and safety (Recommandations sanitaires et de sécurité)

When working on Kelvin Hughes equipment, operators and engineers are expected to work within the Health and Safety guidelines noted in this handbook, as issued by their respective employer or as stated by site regulations, shipyard or the vessel owners.

Risk assessments of a working area must be undertaken prior to the commencement of any work and must be regularly reviewed.

Les opérateurs et les ingénieurs travaillant sur l'équipement Kelvin Hughes doivent se conformer aux consignes relatives à la santé et la sécurité énoncées dans le présent manuel, conformément aux exigences de leurs employeurs respectifs ou comme énoncé dans la réglementation du site, ou par les propriétaires du chantier naval ou du navire.

Des évaluations des risques d'une zone de travail doivent être réalisées avant le démarrage de tout travail et doivent être régulièrement revues.

SCV/SxV ENCLOSURE INTERNAL ACCESS

SharpEye™ SCV and SxV systems are factory sealed units that contain no field serviceable, adjustable or repairable parts.

WARNING

DO NOT DISMANTLE THE RADOME RADAR

Installation engineers, system maintainers or operators must not open or disassemble the radome radar.

Access to components or sub-assemblies within the system is NOT required for any aspect of installation, commissioning, maintenance, fault finding or operation.

Opening the radome radar breaks waterproof seals and voids the warranty status of the unit.

ACCÈS INTERNE À L'ENCEINTE DU SCV/SxV

Les systèmes SCV et SxV de SharpEye™ sont des unités scellées en usine qui ne comportent aucune pièce admettant un entretien, un réglage ou une réparation sur site.

AVERTISSEMENT

NE DÉMONTÉZ PAS LE RADÔME DU RADAR

Les ingénieurs installateurs, les responsables de l'entretien ou les opérateurs du système ne doivent pas ouvrir ni démonter le radôme du radar.

L'accès aux composants ou aux sous-ensembles présents dans le système n'est PAS nécessaire pour l'installation, la mise en service, l'entretien, la recherche de défaillances ou l'exploitation.

L'ouverture du radôme du radar entraîne la rupture de joints étanches et l'annulation de la garantie de l'unité.

HAZARDS

WARNING

ELECTRICAL HAZARDS

The SharpEye™ SCV and SxV radomes are not designed to be open or dismantled.
The equipment has no safety interlocks.

DC VOLTAGES

The system operates from an external DC supply and must be fully isolated from all sources of power prior to carrying out any installation or planned maintenance work.

WARNING

The equipment contains materials which may produce toxic fumes if burnt.

WARNING

The factory sealed SharpEye™ processor within SCV and SxV systems *must not* be dismantled as components within the processor contain Beryllium which can represent a risk if the processor is dismantled.

CAUTION

CAUTION BASEPLATE TEMPERATURE

At ambient temperatures exceeding +50°C, the SCV/ SxV baseplate temperature can exceed +70°C.

SharpEye™ SCV & SxV X-Band Radome Radar
Chapter 2: Health and safety (Recommandations sanitaires et de sécurité)

RISQUES

AVERTISSEMENT

RISQUES ÉLECTRIQUES

Les radômes SCV et SxV de SharpEye™ ne sont pas conçus pour être ouverts ou démontés.
Aucun verrouillage de sécurité n'est prévu sur l'équipement.

TENSIONS CC

Le système fonctionne à partir d'une alimentation CC externe et doit être totalement isolé de toutes sources d'énergie avant de réaliser un travail d'installation ou d'entretien planifié.

AVERTISSEMENT

L'équipement contient des matériaux qui peuvent produire des fumées toxiques en cas d'incendie.

AVERTISSEMENT

Le processeur scellé en usine de SharpEye™ présent dans les systèmes SCV et SxV *ne doit pas* être démonté car les composants de ce processeur contiennent du béryllium qui peut être dangereux si le processeur est démonté.

MISE EN GARDE

MISE EN GARDE TEMPÉRATURE DE PLAQUE DE BASE

À des températures ambiantes dépassant + 50 °C, la température de plaque de base de SCV/SxV peut dépasser + 70 °C.

WORKING ALOFT

WARNING

SAFETY ALOFT

When working aloft or near any radar scanners, moving or RF radiating equipment, ALL power sources to the platform and equipment must be fully electrically and mechanically isolated.
Prior to working aloft, all supply breakers supplying power to the system must be fully isolated and locked into the OFF position. Ensure someone in authority or at ground level knows of your intentions and ensure that suitable clear warnings are in place.
Ensure all means of access aloft are secure and beware of wet or slippery ladder rungs and working areas.
All working at height health and safety requirements and procedures, including the inspection and use of personal protective equipment (PPE) such as approved safety harnesses and gloves, must be adhered to at all times as required by your employer, site regulations, shipyard and / or vessel.

WARNING

SAFETY CORDON

When working aloft, a safety cordon must be established and managed below the working area(s).

WARNING

DROP HAZARDS

When working aloft, all tools and loose items must be safely stowed or secured so that they cannot present a drop hazard.

WARNING

ADVERSE WEATHER CONDITIONS

When weather conditions are poor, a full risk assessment must be carried prior to working aloft as defined by an individual's employer or shipborne safety procedures.
Poor weather conditions can include but are not restricted to high winds, heavy rain, snow, ice or if access is required at sea, risk of vessel pitch and roll.

TRAVAIL DANS LA MÂTURE

AVERTISSEMENT

SÉCURITÉ DANS LA MÂTURE

Lors de travaux dans la mâture ou à proximité d'antennes radar, d'un équipement mobile ou émettant des RF, TOUTES les sources d'alimentation vers la plateforme et l'équipement doivent être totalement isolées électriquement et mécaniquement.

Avant tout travail dans la mâture, tous les disjoncteurs d'alimentation fournissant de l'énergie au système doivent être totalement isolés et verrouillés en position OFF (position éteinte).

Assurez-vous qu'une personne en charge ou sur le terrain connaisse vos intentions et assurez-vous que des avertissements adaptés et clairs sont mis en place. Assurez-vous que tous les moyens d'accès à la mâture sont sécurisés et faites attention aux barreaux d'échelle et aux zones de travail mouillés ou glissants.

Toutes les exigences et procédures sanitaires et de sécurité pour les travaux en hauteur, notamment celles relatives à la vérification et à l'utilisation d'équipements de protection individuelle tels que des harnais de sécurité et des gants homologués, doivent être respectées à tout moment comme exigé par votre employeur, la réglementation du site, du chantier naval et/ou du navire.

AVERTISSEMENT

CORDON DE SÉCURITÉ

Lors d'un travail dans la mâture, un cordon de sécurité doit être établi et géré en-dessous de la ou des zones de travail.

SharpEye™ SCV & SxV X-Band Radome Radar
Chapter 2: Health and safety (Recommandations sanitaires et de sécurité)

AVERTISSEMENT

RISQUES DE CHUTE

Lors d'un travail dans la mâture, tous les outils et les éléments lâches doivent être correctement rangés ou fixés afin qu'ils ne constituent pas un risque de chute.

AVERTISSEMENT

MAUVAISES CONDITIONS MÉTÉOROLOGIQUES

Lorsque les conditions météorologiques sont mauvaises, une évaluation des risques complète doit être réalisée avant un travail dans la mâture, tel que défini par les procédures de sécurité de l'employeur d'un individu ou du navire. Les mauvaises conditions météorologiques comprennent, mais sans s'y limiter, des vents violents, de fortes pluies, de la neige, de la glace ou, si l'accès est nécessaire en mer, le risque de tangage ou de roulage du navire.

RADIATION HAZARDS

WARNING

RADIATION HAZARD NON-IONISING

Avoid exposure to the main beam of a stationary radar antenna.

Avoid standing closer than 15 metres from the central front face of a radiating antenna.

Users of cardiac pacemakers should be aware of the possibility that radio frequency transmissions can damage some devices or cause irregularities in their operation. Anyone using such devices should understand the risks present before exposure.

WARNING

LOSS OF ANTENNA ROTATION ALARM

If a loss of antenna rotation alarm is raised, the DC power to the system should be immediately switched OFF until the cause of the loss of rotation is resolved.

MICROWAVE RADIATION LEVELS

The range at which specified RF exposure limits can be exceeded is far greater for a non-rotating antenna. For that reason, RF transmission without antenna rotation is not a permitted operational mode for this equipment: The system includes interlocks to prevent this occurring.

The basic restriction level for the operating frequency of this product, as set out in 1999/519/EC (Annex III table 2) and calculated in accordance with EN50385:2002, is 10W/m² averaged over a six minute period. For normal operation, the EU basic restriction level for public exposure is only exceeded within 15m of the antenna centre.

In all SharpEye™ systems, the fault condition following the loss of Heading Line and Azimuth data (e.g. the antenna has stopped rotating) will be recognised and trigger the transceiver OFF condition within a few seconds.

SCV-A1-10 SXV-A1-10	Range Within Which the Power Density Exceeds:		
	10W/m ²	50W/m ²	100W/m ²
Rotating	0.8m	0.4m	0.3m
Non-rotating	15m	2.9m	1.4m

Source data document reference TN-2118 issue 2.

NOTICE

It is the responsibility of the end user to ensure that they are working from the latest officially released version of the systems handbook when planning an installation or carrying out any form of risk or hazard assessment.

RISQUES D'IRRADIATION

AVERTISSEMENT

RISQUE D'IRRADIATION NON-IONISANTE

Évitez l'exposition au faisceau principal d'une antenne radar stationnaire.

Évitez de vous tenir à moins de 15 mètres de la face avant centrale d'une antenne rayonnant.

Les utilisateurs de simulateurs cardiaques doivent être conscients du fait que les émissions par radiofréquence risquent d'endommager certains appareils ou causent des irrégularités dans leur fonctionnement. Toute personne utilisant de tels appareils doit comprendre les risques existant avant une exposition.

AVERTISSEMENT

PERTE D'ALARME DE ROTATION DE L'ANTENNE

Lors d'une perte d'alarme de rotation de l'antenne, l'alimentation CC vers le système doit immédiatement être éteinte (position OFF) jusqu'à ce que la cause de la perte de rotation soit résolue.

SharpEye™ SCV & SxV X-Band Radome Radar Chapter 2: Health and safety (Recommandations sanitaires et de sécurité)

NIVEAUX DE RAYONNEMENT MICRO-ONDE

L'intervalle dans lequel les limites spécifiées d'exposition aux RF peuvent être dépassées est bien plus important pour une antenne qui ne tourne pas. C'est pourquoi, l'émission de RF sans rotation de l'antenne n'est pas un mode opérationnel autorisé pour cet équipement. Le système inclut des verrouillages de sécurité pour empêcher une telle situation.

Ce niveau de restriction de base pour la fréquence d'opération de ce produit, comme indiqué dans 1999/519/EC (Annexe III tableau 2) et calculé conformément à EN50385:2002, est de 10 W/m² en moyenne sur une période de six minutes. Pour une opération normale, le niveau de restriction de base de l'UE pour une exposition publique est uniquement dépassé dans un rayon de 15 m du centre de l'antenne.

Dans tous les systèmes SharpEye™, l'état défectueux suivant la perte de données de ligne de foi et d'azimut (par ex., l'antenne a cessé de tourner) sera reconnu et déclenchera l'état désactivé (position OFF) de l'émetteur-récepteur en quelques secondes.

SCV-A1-10 SXV-A1-10	Intervalle dans lequel l'intensité de l'énergie dépasse :		
	10 W/m ²	50 W/m ²	100 W/m ²
État rotatif	0,8 m	0,4 m	0,3 m
État non-rotatif	15 m	2,9 m	1,4 m

ATTENTION

Il est de la responsabilité de l'utilisateur final de s'assurer qu'il ou elle travaille avec les dernières versions publiées officielles du manuel des systèmes lors de la planification d'une installation ou de la réalisation d'une évaluation de risques ou de dangers sous quelque forme que ce soit.

RoHS STATEMENT

Please contact Kelvin Hughes Ltd for details on the SCV/ SxV RoHS (Restriction of Hazardous Substances).

DÉCLARATION RoHS

Veillez contacter Kelvin Hughes Ltd pour plus de détails sur le RoHS (*Restriction of Hazardous Substances*, Restriction sur l'usage de certaines substances dangereuses) du SCV/SxV.

WEEE STATEMENT

Waste Electrical & Electronic Equipment requirements: When a SharpEye™ SCV or SxV system has reached the end of its serviceable, please contact Kelvin Hughes Ltd for safe disposal instructions or alternatively arrange for the sealed unit to be returned to Kelvin Hughes for safe disposal.

SharpEye™ specific disposal notice: The SharpEye™ transceiver(s) located within the sealed transceiver enclosure are factory sealed units that contains no field serviceable parts or lifed components. Components within the SharpEye™ processor (all variants) contain traces of beryllium.

DÉCLARATION DEEE

Exigences liées aux Déchets d'équipements électriques et électroniques : Lorsqu'un système SCV ou SxV de SharpEye™ a atteint la fin de sa durée d'utilisation, contactez Kelvin Hughes Ltd. pour recevoir des instructions d'élimination sans risque ou prévoyez le renvoi de l'unité scellée à Kelvin Hughes pour élimination sans risque.

Recommandations d'élimination spécifique pour SharpEye™ : Le(s) émetteur(s)-récepteur(s) SharpEye™ situé(s) dans l'enceinte scellée de l'émetteur-récepteur sont des unités scellées en usine qui ne comportent aucune pièce admettant un entretien sur site ni de composants à durée de vie limitée. Les composants dans le processeur SharpEye™ (toutes variantes incluses) contiennent des traces de béryllium.

SharpEye™ SCV & SxV X-Band Radome Radar
Chapter 2: Health and safety (Recommandations sanitaires et de sécurité)

VIRUS PRECAUTION

WARNING

ANTIVIRUS WARNING

Prior to use, all computing equipment including removable media that is used on or in Kelvin Hughes products **MUST** be fully scanned for viruses using up to date anti-virus software.

Any media containing potential virus infections must not be used.

Charges relating to systems found to be infected with a virus will be passed onto the company found to be using computing equipment or media that has not been suitably scanned.

Kelvin Hughes cannot be held responsible for damage caused to systems by virus infections. Removable media includes but is not restricted to USB memory sticks, USB hard drives, floppy discs, CD/ DVD's and all forms of removable media.

PRÉCAUTIONS CONTRE LES VIRUS

AVERTISSEMENT

AVERTISSEMENT ANTIVIRUS

Avant utilisation, tous les équipements d'informatique, y compris les supports amovibles, qui sont utilisés sur ou dans les produits Kelvin Hughes **DOIVENT** être entièrement analysés contre les virus en utilisant un logiciel anti-virus à jour.

Tout support potentiellement infecté par un virus ne doit pas être utilisé.

La responsabilité liée aux systèmes qui se révéleraient infectés par un virus incombe à l'entreprise qui ayant utilisé un équipement d'informatique ou un support qui n'aurait pas été analysé correctement.

Kelvin Hughes ne saurait être tenu responsable des éventuels dommages causés au système par des infections par des virus. Les supports amovibles comprennent, mais sans s'y limiter, les clés USB, les disques durs USB, les disquettes, les CD/DVD et toutes autres formes de supports amovibles.

FCC Part 15.19 Warning Statement- (Required for all Part 15 devices)

THIS DEVICE COMPLIES WITH PART 15 OF THE FCC RULES. OPERATION IS SUBJECT TO THE FOLLOWING TWO CONDITIONS: (1) THIS DEVICE MAY NOT CAUSE HARMFUL INTERFERENCE, AND (2) THIS DEVICE MUST ACCEPT ANY INTERFERENCE RECEIVED, INCLUDING INTERFERENCE THAT MAY CAUSE UNDESIRE OPERATION.

FCC Part 15.21 Warning Statement:

NOTE: THE GRANTEE IS NOT RESPONSIBLE FOR ANY CHANGES OR MODIFICATIONS NOT EXPRESSLY APPROVED BY THE PARTY RESPONSIBLE FOR COMPLIANCE. SUCH MODIFICATIONS COULD VOID THE USER'S AUTHORITY TO OPERATE THE EQUIPMENT.

FCC Part 15.105(b) Warning Statement- (ONLY required for 15.109-JBP devices)

NOTE: This equipment has been tested and found to comply with the limits for a Class B digital device, pursuant to part 15 of the FCC Rules. These limits are designed to provide reasonable protection against harmful interference in a residential installation. This equipment generates uses and can radiate radio frequency energy and, if not installed and used in accordance with the instructions, may cause harmful interference to radio communications. However, there is no guarantee that interference will not occur in a particular installation. If this equipment does cause harmful interference to radio or television reception, which can be determined by turning the equipment off and on, the user is encouraged to try to correct the interference by one or more of the following measures:

- Reorient or relocate the receiving antenna.
- Increase the separation between the equipment and receiver.
- -Connect the equipment into an outlet on a circuit different from that to which the receiver is connected.
- -Consult the dealer or an experienced radio/TV technician for help.

Déclaration de mise en garde de la partie 15.19 de la FCC

(Requis pour tous les appareils visés par la partie 15)

CET APPAREIL EST CONFORME À LA PARTIE 15 DES RÈGLES DE LA FCC. SON FONCTIONNEMENT EST SOUMIS AUX DEUX CONDITIONS SUIVANTES : (1) CET APPAREIL NE DOIT PAS CAUSER D'INTERFÉRENCES NUISIBLES, ET (2) CET APPAREIL DOIT ACCEPTER TOUTE INTERFÉRENCE REÇUE, NOTAMMENT CELLES POUVANT ENTRAÎNER UN DYSFONCTIONNEMENT.

Déclaration de mise en garde de la partie 15.21 de la FCC

NOTE : LE BÉNÉFICIAIRE N'EST PAS RESPONSABLE EN CAS DE TRANSFORMATIONS OU MODIFICATIONS NON EXPRESSÉMENT AUTORISÉES PAR LA PARTIE RESPONSABLE DE LA CONFORMITÉ. DE TELLES MODIFICATIONS SONT SUSCEPTIBLES D'ENTRAÎNER LA RÉVOCATION DE L'AUTORISATION D'UTILISATION DE L'ÉQUIPEMENT.

Chapter 2: Health and safety (Recommandations sanitaires et de sécurité)

**Déclaration de mise en garde de la partie 15.105(b) de la FCC
(uniquement requise pour les appareils JBP visés par 15.109)**

NOTE : Cet équipement a été testé et déclaré conforme aux limites pour les appareils numériques de classe B, selon la partie 15 des règles de la FCC. Ces limitations sont conçues pour fournir une protection raisonnable contre les interférences nuisibles dans un environnement domestique. Cet équipement génère, utilise et peut irradier de l'énergie radiofréquence et, dans le cas d'une installation et d'une utilisation non conformes aux instructions, il peut provoquer des interférences nuisibles aux communications radio. Cependant, il n'existe aucune garantie qu'aucune interférence ne se produira dans une installation particulière. Si cet équipement provoque des interférences nuisibles à la réception radiophonique ou télévisuelle, ce qui peut être détecté en mettant l'appareil sous et hors tension, l'utilisateur peut essayer d'éliminer les interférences en suivant au moins une des procédures suivantes :

- Réorienter ou repositionner l'antenne de réception.
- Augmenter la distance entre l'équipement et le récepteur.
- Brancher l'équipement sur une prise appartenant à un circuit différent de celui sur lequel est branché le récepteur.
- Consulter un distributeur ou un technicien radio/télévision qualifié pour obtenir de l'aide.

3 Introduction

3.1 System overview



SCV-A1-10 Small craft variant

The **SharpEye™ SCV** is an X-band lightweight coherent radome radar utilising core SharpEye™ technology. The SharpEye™ transceiver has been designed for watercraft ranging from RHIBs up to 35m and fast watercraft operated by coastguards, search and rescue, customs, police, Special Forces, armies or navies.



SxV-A1-10 Land surveillance

The **SharpEye™ SxV** is an X-band system that is mechanically and electronically identical to the SharpEye™ SCV series however the clutter performances have been enhanced for fixed or mobile land based applications.

Features:

The SharpEye™ SCV and SxV series offers low cost, low power consumption, lightweight design, ultra-high reliability and superior performance

Key features of the SCV/ SxV include:

- Simple connectivity with two waterproof connections for DC power and LAN connection
- Anti-jamming
- Low power counter surveillance/ covert mode
- GNSS position and heading output



Power:

The system operates from a +24 to +30VDC power source.

Radome radar:

The SharpEye™ SCV and SxV radome radars are sealed units that contain the following key components:

- A 530mm horizontally polarised array
- SharpEye™ transceiver processor
- Internal DC/DC power supply
- A Gigabit Ethernet LAN interface (see section 10.2 for details on compatible Network Switches)

Detection:

Doppler processing enables the detection of extremely small and slow targets in inclement weather conditions day or night.

Mounting:

The SCV and SxV has been designed for easy installation on radar arches, masts, static masts and tripods and has a flexible interface making the system display independent.

Environmental:

The systems have been designed to withstand the vibration and shock levels found on RHIBs, small craft, vehicles etc. and be dustproof and waterproof to IP67.

System integration:

Additional details on system integration are available upon request. Please contact Kelvin Hughes Ltd for information, contact details can be found at the end of this publication.

SharpEye™ SCV & SxV X-Band Radome Radar
Chapter 3: Introduction

3.2 Display interfacing

The SCV/ SxV X-Band radome radars are designed to be interfaced via a LAN connection to a suitable command and display sub-system.

COMMISSIONING NOTICE

This handbook details the installation, termination and maintenance of the SCV/ SxV only and does not cover the commissioning or operation of third party equipment or display sub-systems.

3.3 Typical systems

Kelvin Hughes Ltd NAVIGATION DISPLAY

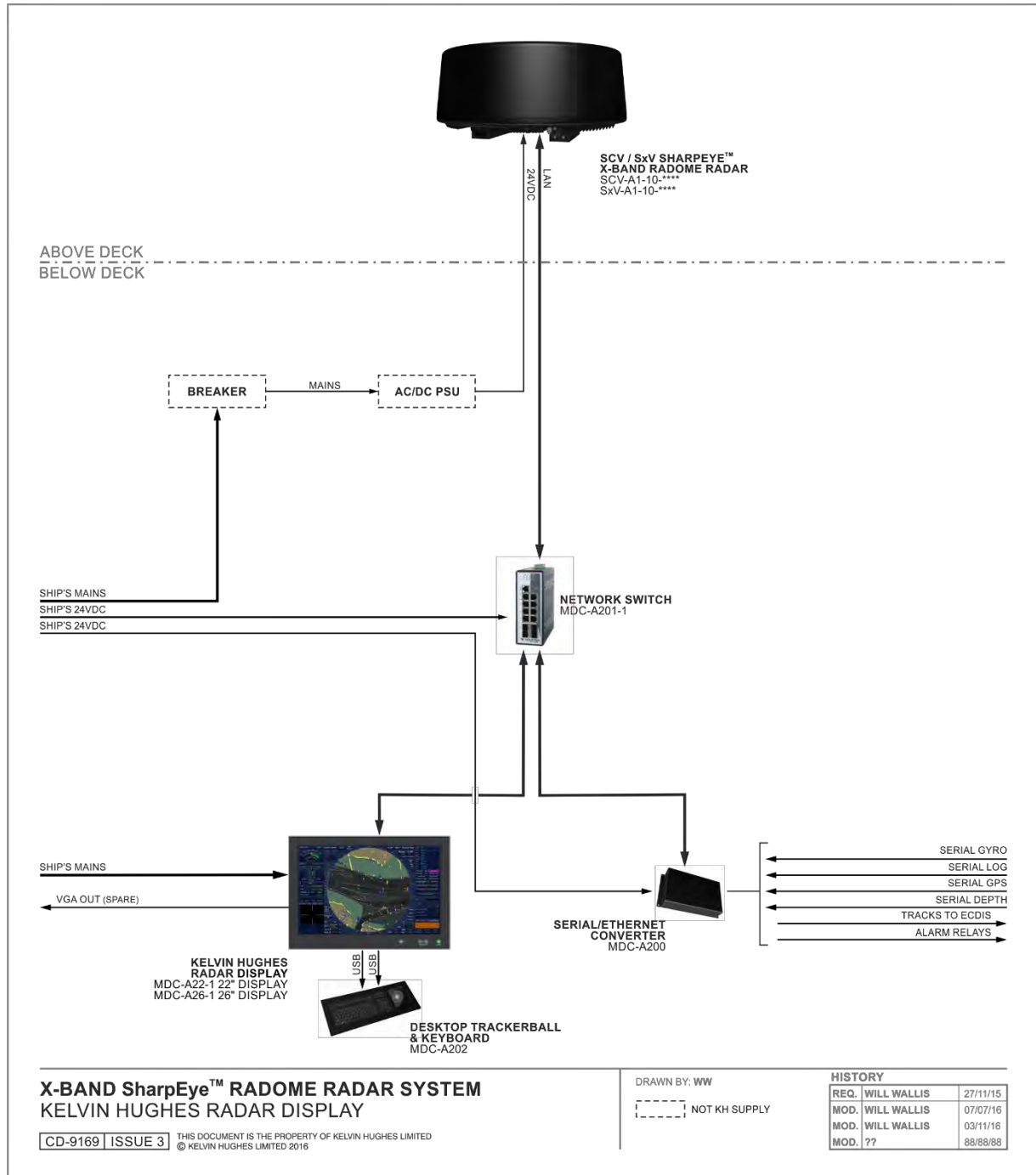

SharpEye™ SCV & SxV X-Band Radome Radar
Chapter 3: Introduction

SMALL CRAFT DISPLAY

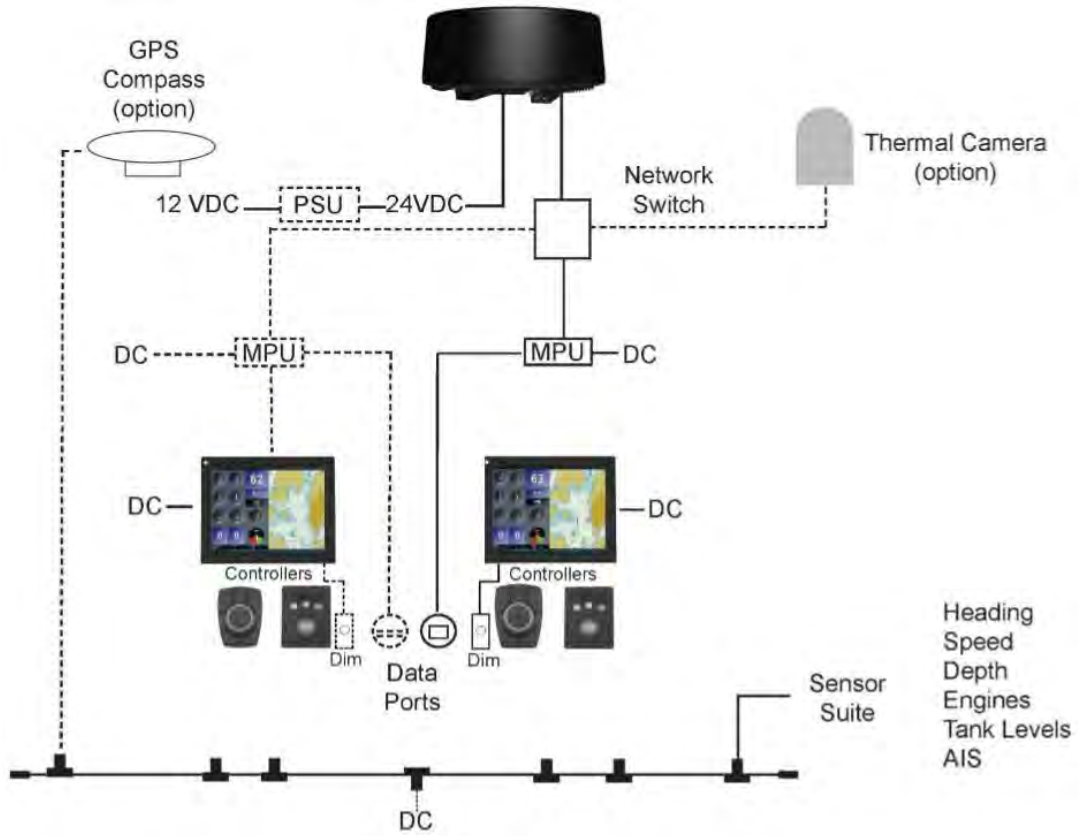

Example of an SCV integrated with a small craft display
A second display for an additional command position is shown with dotted lines

Page intentionally blank

4 Positioning of radar equipment

To achieve the full potential of a radar system there must be no obstructions in the path of the beam from the antenna. In practice however obstructions occur some of which are unavoidable. In the case of the SCV these obstructions include interactions with the masts, sponsons, the vessel superstructure and the sea conditions. In SxV applications these obstructions can include buildings and land masses.

The proximity of the radar to infrastructure such as masts, aerials etc. is an important consideration as, due to the high level of sensitivity of modern radar receivers, the reflected signals can manifest as false echoes on the radar display.

Where available, the appropriate use of blanking sectors to prevent radar transmission towards an obstruction limits the appearance of false echoes. Where infrastructure is located in the field of view of the antenna this is not always possible.

The SCV/ SxV should be mounted as high as is practical given the constraints of the installation being considered.

BLOCKAGE AND REFLECTION

Interaction of the radar antenna beam with an obstruction impacts the performance of the radome radar and may be considered under two headings which are detailed below:

Blockage: Where part of an obstruction is directly in the path of the beam from the antenna.

Reflection: Where energy from the antenna reflects from part of a structure.

Clearly, when part of a structure is directly in the path of the beam from the antenna then reflection will also occur.

Note: The effects discussed in the following are not only related to metallic structures. All objects, whether they are metal, plastic, wood, etc. can cause blockage and reflection resulting in the effects discussed.

BLOCKAGE: The drawing to the right shows a mast and antenna in plan view giving an example of blockage by a mast. Notice how the blockage can impact on the energy from the antenna over a large scan angle depending on how close the obstacle is to the antenna and its size.

As an example, an obstacle that is 3m away from a 0.53m wide SCV/ SxV antenna will be in the path of the beam over an angle of at least 10°, depending on the width of the obstacle.

The effect of this form of blockage is to reduce the power returned from a target and to increase the clutter received by the radar so that the ability to detect the target is degraded (and a blind spot may even occur).

This degradation in performance of the radar occurs while the obstacle remains in the antenna beam although it reduces as the blockage moves towards the edge of the beam. The magnitude of the blockage effect is dependent on the size and physical characteristics of the obstacle. As the size of the object increases, so does the degradation in radar performance.

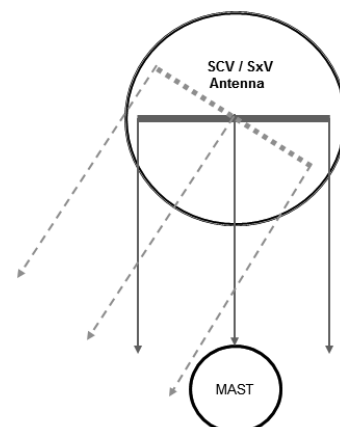

Antenna Beam Blockage by a Mast

SharpEye™ SCV & SxV X-Band Radome Radar
Chapter 4: Positioning of radar equipment

Clearly, when the obstacle is as large or larger than the antenna the radar becomes completely blind although, as already indicated, blind spots may still occur when the obstacle is smaller than the antenna.

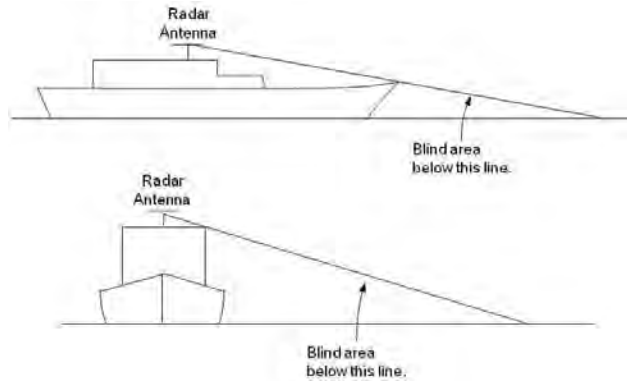

Whilst the most obvious features on a vessel (SCV) leading to blockage are masts, funnels, railings, etc.

Decks and cabin roofs can also cause blockage if the antenna is not mounted sufficiently high.

The same effect can occur when mounting the SxV on a building or mast.

REFLECTION: The drawing to the right shows a mast and antenna in plan view, the mechanism of reflection is from an obstacle such as the mast.

Energy from the antenna is reflected in a different direction to that in which the antenna is pointing. If this is incident on a target, then reflections from the target will return via the same path.

If the reflections have sufficient magnitude they will produce a return on the display in a direction corresponding to the pointing angle of the antenna, thus producing a ghost target.

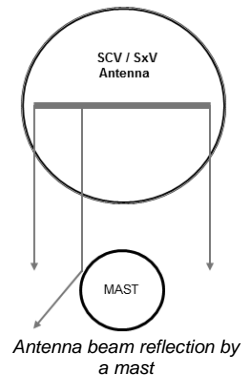

The angular position of such ghost targets will be dependent on the shape of the obstacle and some obstacles will produce ghost targets which are close to the real target, thus resulting in target smearing. Masts and funnels will generally tend to produce distinct ghost targets and railings are likely to lead to target smearing.

On some installations such as modern high speed vessels where a large portion of the deck or mounting surface may be within the antennas vertical beamwidth, the radar signal is likely to be reflected. Horizontal surfaces will tend to reflect the radar signal upwards away from other reflectors causing no problem. Inclined or curved surfaces can reflect energy from the antenna into the horizontal plane at a different angle to the pointing angle of the antenna. This can lead to ghost returns and/ or target smearing.

Similar effects can occur on static or vehicle installations.

SEA & LAND CLUTTER

Sea and land clutter returns are not only dependent on the sea state but also on the height of the radar antenna. As the antenna height increases so does the sea clutter returns and the range out to which the sea clutter extends.

HORIZON RANGE

The curvature of the earth limits the range that can be seen by a radar system.

The table opposite demonstrates the approximate range to horizon on a generic radar system.

Antenna height above sea level (metres)	Horizon range (NM)	Horizon range (km)
5.0m	5.0NM approx.	9.3km approx.
10m	7.0 NM approx.	13km approx.
15m	8.5 NM approx.	15.7km approx.
20m	10 NM approx.	18.5km approx.

MULTIPATH INTERFERENCE

Radar energy reflects from the target directly or following reflection at the surface of the sea. The result is that sometimes the two signals will reinforce each other while at other times they will cancel and create a null.

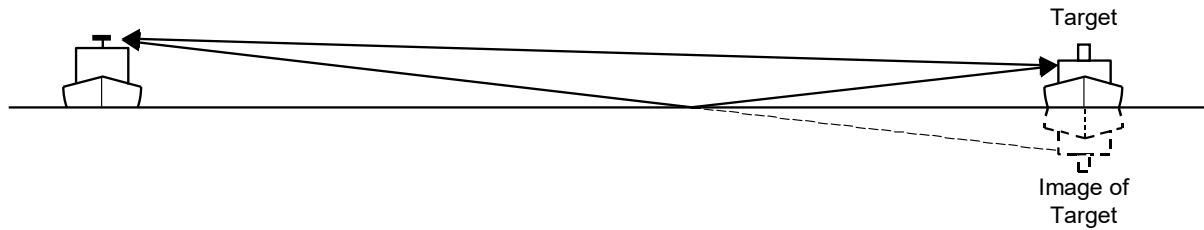

In marine applications (SCV) Multipath is most pronounced when the sea is calm, acting like a mirror, and when the target is simple (essentially comprising a single reflector) such as a buoy. Here multipath reflection may produce a large number of signal nulls at short range. These become less frequent as range increases.

In the higher sea states when the sea is rough and is less like a mirror or when the target is complex (comprising a number of reflectors), as are many vessels, the effect of multipath is less pronounced so that the nulls are less deep.

Land based installations can also suffer from multipath. The reflection characteristics can change based on terrain, dampness etc.

As the height of the radar antenna (or target) increases, then the frequency of the nulls also increases.

It is clear that there is no definitive solution to the installation of a radar antenna on a vessel or a permanent land based site.

Each installation should be examined on its own merit with each aspect of performance assessed appropriately. To this end, we advise that you seek guidance from Kelvin Hughes for antenna installations by submitting a drawing illustrating the position of the antenna in relation to the vessel's structure (SCV) or mounting structure (SxV) and nearby obstacles.

ANTENNA LOCATION AND SEPARATION

SharpEye™ SCV and SxV radomes contain a SharpEye™ radar transceiver and a GNSS antenna. The system must be mounted with a clear view of the horizon.

Wherever possible, ensure the antenna is placed outside the beam path of any other transmitting equipment for example:

- | | |
|------------------|--|
| Radar: | Typically $\pm 15^\circ$ from the array's centre point. |
| Satcom: | INMARSAT A, B, C, or M; typically $\pm 10^\circ$ from the array's centre point in any of the possible transmitting directions. |
| VHF/ SSB: | Do not place within 3 metres of a VHF or SSB radios or their antennas. |

Page intentionally blank

5 Preparation for installation

5.1 Pre-Installation requirements

SCV and SxV systems have been designed as 'plug and play' units that should be installed by competent engineers familiar with the installation and commissioning of radar equipment.

- Installation engineers should familiarise themselves with all sections of this handbook prior to carrying out any installation, commissioning or maintenance tasks on SCV/ SxV products.
- The SCV/ SxV must be mounted and terminated as instructed in this handbook.
- Incorrect or poor installation of the equipment can invalidate the warranty of the system.

UNIT INSPECTION

The SCV/ SxV has been designed with protective coatings and finishes to allow it to withstand demanding environments around the world. However if the unit sustains mechanical damage, such as scores or scratches that is sufficient enough to damage the coatings and expose underlying metal, the unit's ability to withstand salt corrosion may be reduced.

Damage to finishes or metalwork should be made good immediately.

The unit should be protected from potential damage by other equipment, for example accessing or installing other equipment in the vicinity of the SCV.

Care should be taken when mating and de-mating connectors so that the shell finish of the connectors is not damaged.

Prior to installation, the unit should be checked to ensure that no damage has occurred during transport. Any damage that has occurred, including accidental dropping of the unit, must be reported to Kelvin Hughes Ltd before the unit is installed.

Damage must only be repaired when authorised by Kelvin Hughes Ltd.

TOOLS

In addition to the normal tools required for installation and service work, the following will be required to install the SCV or SxV radomes:

- M4 / 7mm spanner (SCV brackets)
- M6 / 10mm spanner (earth connections)
- M8/ 13mm spanner (main mounting bolts).
- Torque wrench (tightening the main chassis bolts to 22Nm). *Note*
- Multimeter / safety ohmmeter or bridge megger (earth bonding tests)

NON-REMOVABLE RADOME COVER

The 8 bolts that retain the radome cover to the chassis and **MUST NEVER BE REMOVED**. Access to components or sub-assemblies within SCV or SxV systems is NOT required for any aspect of installation, commissioning, maintenance or operation.

CAUTION

Removal of the radome cover invalidates the warranty status of the system and breaks waterproofing seals.

GENERAL PRECAUTIONARY NOTICES

- The radome must not be painted.
- Labels and/ or stickers must not be placed on the radome.

DRT TORQUE VALUES

Torque settings noted in this handbook are dry torqueing values. Appropriate wet torque values should be used as appropriate. Please contact Kelvin Hughes if additional information is required.

SharpEye™ SCV & SxV X-Band Radome Radar
Chapter 5: Preparation for installation

5.2 Fitting kits

KIT CONTENTS

Typically the SCV/ SxV system is supplied with an installation kit that includes:

- **FIXINGS**
All the necessary fixings required to mount the SCV/ SxV. Fixings supplied are 316 (A4) grade stainless steel, passivated, zinc plated for marine applications
- **ANTI-VIBRATION MOUNT**
An anti-vibration mount is provided as standard with SCV systems and can be ordered separately for SxV systems (detailed in the fitting kits below).

Before commencing the installation, check the kit contents of this against the packing list contained within the kit, ensuring all necessary parts are present. Any missing or damaged parts should be immediately reported to Kelvin Hughes Ltd.

SCV	SCV-A160-1 fitting kit	
SCV-A172	Anti-vibration mount	The anti-vibration mount is supplied as standard and MUST BE INSTALLED on all SCV applications. Please refer to section 6.1 for assembly details.
SCV-A170	Cable bracket assembly	This assembly is assembled onto the anti-vibration plate. Please refer to section 6.2 for assembly details.
SCV-A145	Earth strap	Earth strap that must be used to connect the radar to a tested / proven earth/ ground. Please refer to section 7.4 for assembly details.
55-100-0566-001	Anti-Corrosion Paste / grease	10ml Syringe of anti-corrosion paste/ grease. Please refer to section 6.3 for application details.
Fasteners Nuts, bolts & washers	M4 M8 x 25mm	Used to assemble the SCV-A170 / SCV-A172 to the SCV.
	M8 x 45mm	Used to fix the SCV to its mounting position See notes in section 6.3 regarding maximum thread depths.

SxV	SXV-A100 fitting kit	
SCV-A145	Earth strap	Earth strap that must be used to connect the radar to a tested / proven earth/ ground. Please refer to section 7.4 for assembly details.
55-100-0566-001	Anti-Corrosion Paste / grease	10ml Syringe of anti-corrosion paste/ grease. Please refer to section 6.3 for application details.
Fasteners Nuts, bolts & washers	M8 x 25mm	Used to fix the SCV to its mounting position See notes in section 6.3 regarding maximum thread depths.
	SCV-A135 (OPTIONAL)	Anti-vibration mount
		An anti-vibration mount is not supplied as part of an SxV installation kit but can be requested as a chargeable option for use in situations where vibration is anticipated.

CABLES

Typical installation kits do not contain cabling for the SCV and SxV which must be ordered separately.

SCV/ SxV	Standard cables part numbers
SCV-A167-** Note 1	Power Input cables. Standard length is 10m. 15, 20, 25 & 30m lengths are available on request. Refer to section 7.2. Connects DC power to the radar assembly.
SCV-A168-** Note 2	Ethernet Cable. Standard length is 10m. 15, 20, 25 & 30m lengths are available on request Connects the radar assembly to the control system and provides communications (Control and Video) to and from the unit. The cable supports Gigabit Ethernet.

Note 1: Where -** is the cable length in metres, e.g. a standard 10m Power cable would be SCV-A167-10.

Note 2: SCV variant SCV-A1-10-ADAC should be ordered with power cable SCV-A177-** rather than SCV-A167-**. Please contact Kelvin Hughes Ltd if alternative cable assemblies are required.

5.3 Location

POSITION

The installation of the equipment needs to be assessed against local operating procedures; please refer to section 4 for additional information on the positioning of radar equipment.

RADHAZ PRECAUTIONS

If video ceases to be displayed and the SCV/ SxV is installed in a position where a person can be within 15m of the antenna, the operator should cease transmission immediately and investigate the problem, ensuring that the SCV is not at fault. Please refer to the Radiation Hazard warning notices that can be found in section 2: Health & Safety notices and in the operator notices in section 10: Operator instructions.

DO NOT STEP

The SCV / SxV should never be placed in a position where it can be used as a step or aid to climbing. Do not stand on the SCV / SxV radar.

5.4 Lifting considerations

LIFTING EQUIPMENT

- All health & safety requirements as laid down by the vessel, shipyard or site safety regulations must be checked and observed at all times when lifting any equipment. Any applicable local or national regulations must also be observed
- In line with Kelvin Hughes, shipyard, vessel and/ or site requirements, all appropriate Personal Protective Equipment (PPE) such as safety harnesses, fall arresters, hard hats, safety boots, safety glasses and gloves must be inspected prior to use and worn at all times when lifting equipment and when working aloft.
- Never leave equipment unsupported on a mounting platform.
- Ensure that tools or equipment cannot present any form of drop hazard.
- Where special equipment such as cranes hoists and jigs is required, consideration must be given to the authority to use such equipment.
- During lifting, a safety zone shall be established beneath the lifting area, around any cranes or platforms. Safety personnel must ensure that persons do not encroach into the area of work.
- When making arrangements for lifting any equipment, consult with the lifting operator to obtain the best and safest method of securing the lifting strops or ropes to the equipment.
- Lifting operators should be advised of the areas of a system that are susceptible to damage such as the SCV or SxV radome cover.
- Check that the centre of gravity of the equipment cannot cause the lifting strops or ropes to slip or move.

MANUAL LIFTING

- The SCV/ SxV radome radar weights approximately 22Kg (SCV with anti-vibration mount & cable bracket fitted) or 20kg (SxV) so may be manually lifted by two-people.

In addition to the precautions noted above, all manual lifting requirements and precautions must be observed when lifting the equipment.

Page intentionally blank

6 Mechanical installation

6.1 Mounting platform

MOUNTING PLATE

The SCV/ SxV radome radar requires an 8.0mm flat aluminium or steel mounting plate.

The plate should be pre-drilled to accommodate the radome radar, an earthing/ grounding point, any cables access holes and cable restraining points.

Prior to installation, the proposed mounting plate and location must be inspected and accepted as being suitable.

All four planes shown (A, B, C and D) should be checked to ensure the surface is flat and that there is no curvature of the plate. The maximum deviation should not exceed 1.0mm.

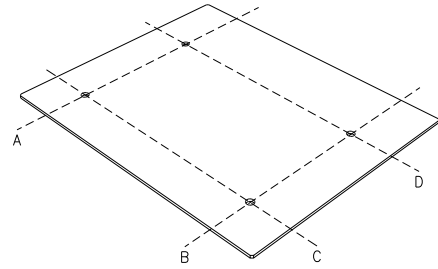

Example of SCV and SxV mounting plate.
Not to scale.
See following pages for dimensions

The mounting platform and any supports (masts etc.) must be able to fully support the weight of the radome radar and be designed to minimise vibration.

MOUNTING BARS

The full mounting surface area of the SCV/ SxV chassis must be in contact with the mounting plate.

Kelvin Hughes STRONGLY advises against mounting the SCV/SxV on brackets or mounting bars as this can cause twisting of the radome radar chassis. A flat, even surface is strongly recommended.



Mounting brackets, bars or tubes are **NOT** recommended.

EARTHING/ GROUND POINT

A tested/ proven ground point grounding/ earthing point will be required on the mounting plate or platform for connection to the M6 earth stud located on the base of the radome radar. See section 6.4 (SCV) or section 6.5 (SxV) for the location of the earth stud. Kelvin Hughes Ltd recommend that the earth/ ground connection is always connected to the common platform chassis ground.

BATTERY CONNECTION

Portable systems powered by a battery do not require an earth connection

ORIENTATION

- The SCV/ SxV radome radar must be mounted in an upright position as shown below with the LAN and DC connectors pointing backwards/ aft.
- Due to the beamwidth of the antenna, target detection will be significantly reduced if the SCV/ SxV assembly is tilted by more than 12.5° from horizontal/ flat.

Please consult with Kelvin Hughes Ltd if alternative mounting positions (i.e. inverted etc.) are required.

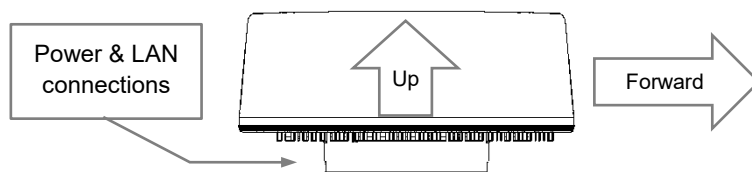

6.2 Anti-vibration mount/ Cable bracket assembly

SCV APPLICATIONS (MOUNT SUPPLIED)

SCV-A170 Anti-Vibration Mount

The Anti-Vibration mount and cable bracket assembly are supplied pre-assembled as part of the SCV-A160-1 fitting kit ready for fitting to an SCV.

These assemblies must be fitted to the SCV prior to placing the unit on its final mounting position.

SXV APPLICATIONS (OPTIONAL)

SCV-A135 Anti-vibration mount

An anti-vibration mount is not supplied as part of an SxV installation kit but can be requested as an option for use in situations where vibration is anticipated.

Where required, the mount must be fitted to the SxV prior to placing the unit on its final mounting position.

FASTENERS

The Fasteners supplied in the installation kit must be used as follows:

M4 nuts and washers	Used to Assemble the SCV SCV-A170 to the SCV-A172.
M8 x 25mm bolts and washers	Fixes the combined SCV-A170 and SCV-A172 to the base of the SCV.
M8 x 45mm and washers	Used to fix the SCV to its mounting position. ^{Note} See notes in section 6.3 regarding maximum thread depths.

INSTALLATION PRECAUTIONS

- The SCV will need to be inverted to fit the Anti-vibration plate and the cable support bracket. The unit should be placed on a surface that will protect the radome from being scratched or damaged.
- Do not apply un-necessary force to the base of the unit as this could deform the radome cover.
- During installation, the 20mm maximum thread depth of the main SCV/SxV mounts or the anti-vibration mounts should never be exceeded (see section 6.3 for additional details).

Note: The 8 x 45mm bolts are for SCV applications where the combined SCV-A170 and SCV-A172 plates have been fitted.
For application where no anti-vibration/ cable bracket plates are fitted please use the M8 x 25mm bolts from the fitting kit.

SharpEye™ SCV & SxV X-Band Radome Radar

Chapter 6: Mechanical installation

SCV-A170 CABLE BRACKET ASSEMBLY

Parts List			
ITEM	PART NUMBER	QTY	TITLE
1	SCV-2026	1	CONNECTOR SUPPORT BRACKET
2	SCV-2027	2	CONNECTOR SUPPORT BRACKET 2
3	SCV-2037	2	CONNECTOR SUPPORT BRACKET 4
4	25-272-1151-01	8	NUT HEX NYLOC M6
5	55-100-0571-001	1	DIA 7.8 ROUND PVC CABLE GROMMET
6	55-100-0572-001	1	DIA 10.5 ROUND PVC CABLE GROMMET

USED ON	ALL DIMENSIONS IN MILLIMETRES (UNLESS OTHERWISE STATED)	TOLERANCES UNLESS OTHERWISE STATED	MATERIAL	TITLE
SCV-A1-10-ADAC				SCV-CABLE BRACKET ASSEMBLY
DRAWN BY	J.W.			SCV-A170

SCV-A172 ANTI-VIBRATION MOUNT KIT

Parts List			
ITEM	QTY	PART NUMBER	TITLE
1	1	SCV-1025	VIBRATION MOUNTING PLATE
2	4	25-252-1315-27	SCREW HEX HD M8 X 30 LG ST STEEL
3	4	25-262-1417-01	CAP HEAD SCREW M4X20
4	12	25-262-1418-01	CAP HEAD SCREW M4X10
5	32	25-281-3075-27	WASHER PLAIN M4
6	8	25-281-3076-27	WASHER PLAIN M6 STN STL ZINC PLATE & PASS
7	8	25-282-002	WASHER SINGLE COIL M8
8	16	25-282-006-27	M4 S/COIL SPRING WASHER
9	4	55-100-0513-001	ANTI VIBRATION MOUNT
10	1	85-812-450-04	BAG POLYTHENE
11	4	ZV-9667	SCREW HEX HD M8 X 20 LG ST STEEL

NOTES:

1. SCREWS M8x55 LG (ITEM 1), M6 SINGLE COIL WASHER (ITEM 7) & M6 PLAIN WASHER (ITEM 6) TO BE PLACED INTO POLYTHENE BAG (ITEM 10).

2. FIT SCREWS (ITEM 2) & WASHERS (ITEMS 6&7) INTO ANTI-VIBRATION MOUNTS. FINGER TIGHT.

USED ON	ALL DIMENSIONS IN MILLIMETRES (UNLESS OTHERWISE STATED)	TOLERANCES UNLESS OTHERWISE STATED	MATERIAL	TITLE
SCV-A1-10-ADAC				ANTI VIBRATION MOUNT KIT
DRAWN BY	V.M.			SCV-A172

INSTALLATION PROCEDURE

- A. Invert the SCV assembly ensuring the unit is placed on a surface that will not damage or scratch the top of the radome casing.
- B. SCV-A170 cable bracket assembly rests in-between the two connectors as shown below.
- C. The SCV-A172 anti-vibration plate is fitted with four anti-vibration mounts. One of these mounts has longer fasteners that protrude below the plate. These longer fasteners align with the slots in the SCV-A170 cable bracket assembly and are secured using the M4 fasteners, plain and spring washers found in the fitting kit.
TIP: Fit the anti-vibration plate to the cable bracket assembly and loosely tighten the 4 longer fasteners. Align the cable bracket assembly then align the anti-vibration plate with the 4 main fastening holes on the base of the transceiver. The assembly can then be removed and the longer shock mount screws can be fully tightened.
- D. The assembly can be fastened to the SCV using the M8 x 25mm bolts, plain and spring washers provided in the fitting kit.
- E. Tighten the main bolts to a torque of 22Nm (see precautions in section 6.3).

EXAMPLE OF MOUNTING

SCV-A170 cable bracket assembly placed onto an SCV.



SCV-A172 anti-vibration plate showing the four longer mounting fasteners (circled) that align with the A170 cable bracket assembly.



Completed assembly shown prior to the four mounting bolts being fitted.

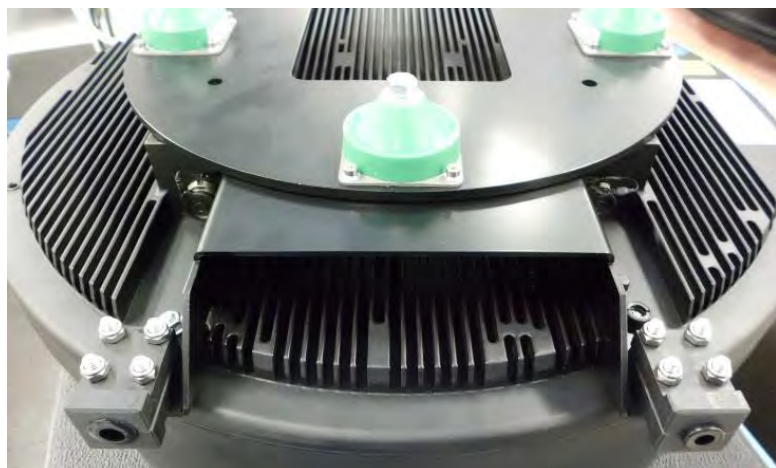

Example of bolt and washer arrangement

6.3 Installation

MOUNTING BOLTS

The radome radar is secured to the mounting plate using four M8 stainless steel bolts and washers supplied in the fitting kit (see previous page for washer arrangements). The mounting bolts supplied in the fitting kit **MUST** be used to fix the SCV/SxV to the mounting platform as detailed in the following table:

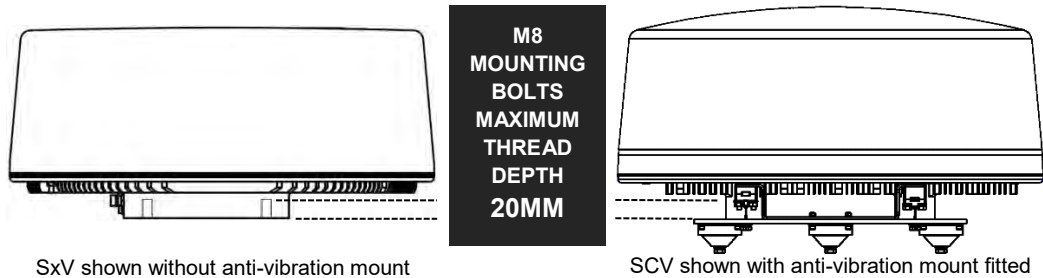

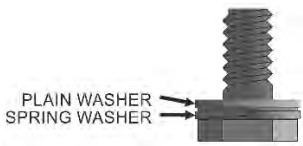
<p>SCV INSTALLATIONS or Installations where the SCV-A170 Cable bracket assembly and SCV-A172 anti-vibration mount are fitted.</p>	<p>M8 x 45mm bolt and washers</p>	 <p>PLAIN WASHER SPRING WASHER</p> <p>Example of bolt and washer arrangement</p>
<p>SxV INSTALLATION or Installations WITHOUT the SCV-A170 Cable bracket assembly and SCV-A172 anti-vibration mount</p>	<p>M8 x 25mm bolt and washers</p>	

Please contact Kelvin Hughes Ltd if alternative fasteners are to be used.

MAXIMUM THREAD DEPTH

The depth of the thread for the M8 fasteners in the radome radar is **20mm maximum** tightened to a torque load of **22Nm** (see illustration above). In general, unless otherwise stated, the absolute minimum engagement depth for fixings is 1.5 x diameter.

IMMERSIBLE BREATHER HEAD



The breather head protects the system against air pressure build up within the radome whilst preventing water ingress. The maintenance free breather is a factory fitted component and **MUST NOT** be painted, pierced, covered or removed.

ANTI-CORROSION PASTE/ GREASE

Lightly grease the threads of the mounting bolts prior to fitting using the tube of grease provided in the fitting kit.

If this is not available, the preferred material for the grease is Molybdenum Disulphide (Kelvin Hughes part number 55-100-0562-001).

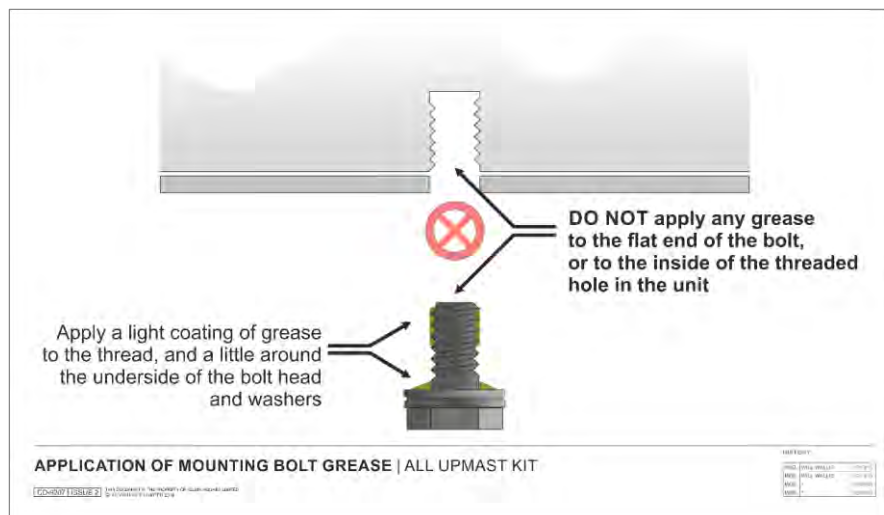

SharpEye™ SCV & SxV X-Band Radome Radar
 Chapter 6: Mechanical installation

6.4 DIMENSIONS: SCV

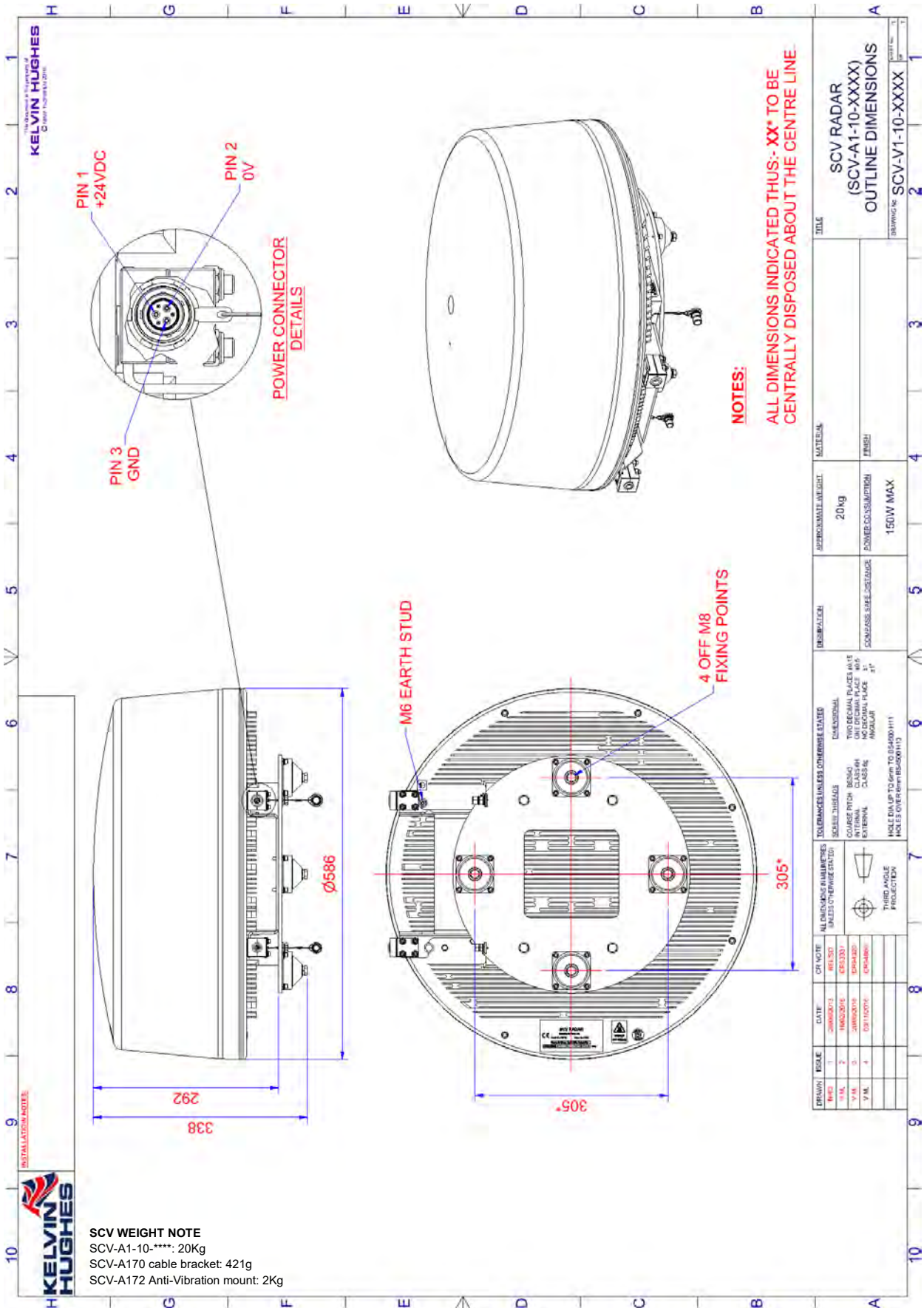

SharpEye™ SCV & SxV X-Band Radome Radar
 Chapter 6: Mechanical installation

6.5 DIMENSIONS: SxV

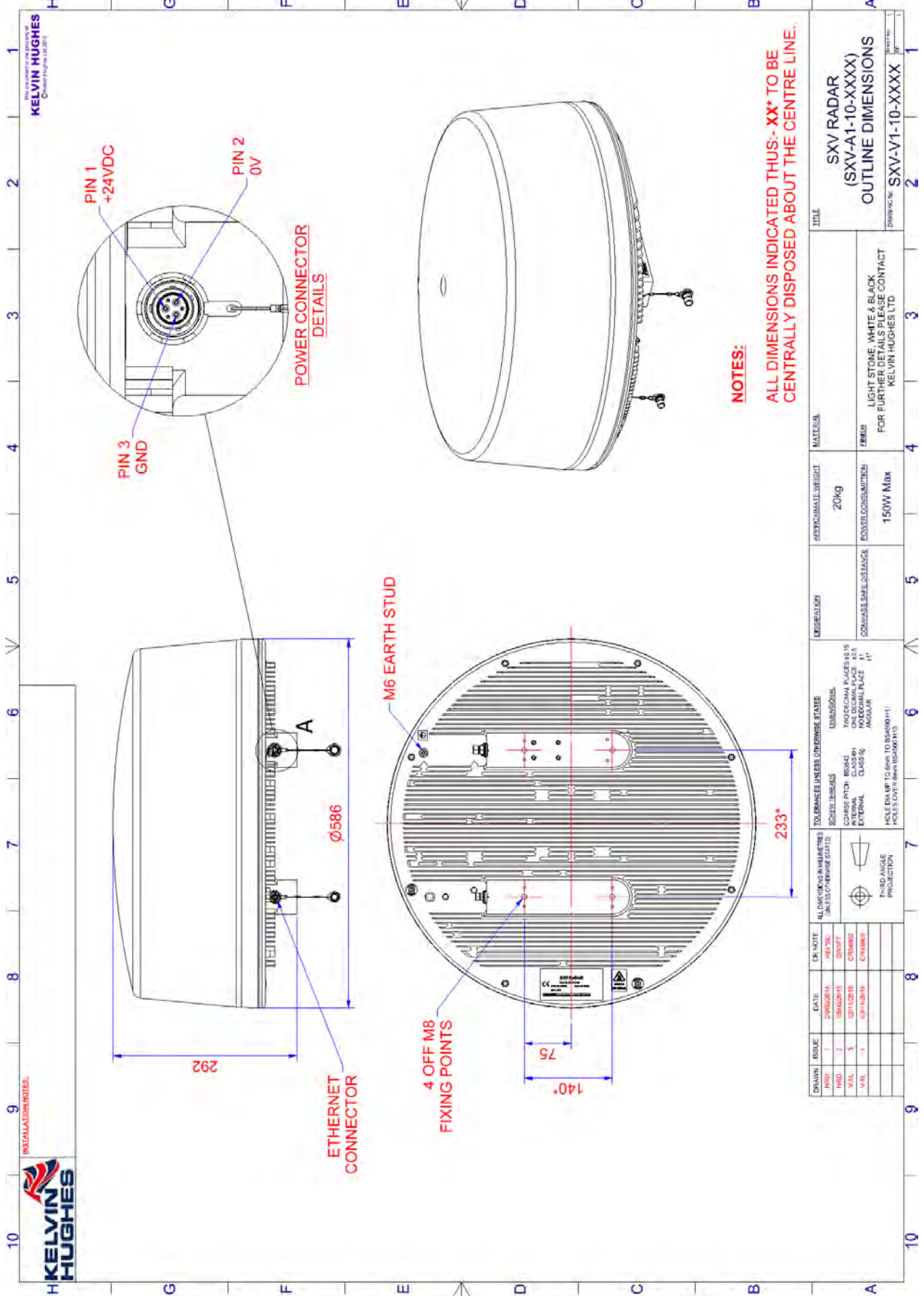

NOTES:
 ALL DIMENSIONS INDICATED THUS:- XX* TO BE CENTRALLY DISPOSED ABOUT THE CENTRE LINE.

DRAWN	ISSUE	DATE	EN-NOTE	ALL DIMENSIONS IN MILLIMETRES UNLESS OTHERWISE STATED	TOLERANCES UNLESS OTHERWISE STATED	DESCRIPTION	APPROXIMATE WEIGHT	MATERIAL	TITLE
PHD	1	20/05/14	REVISED	SQRTZ LINEAR	±0.10	DESCRIPTION	20kg	FIBRE	SXV RADAR (SXV-A1-10-XXXX) OUTLINE DIMENSIONS
PHD	2	20/05/14	REVISED	INTERNAL	±0.10	DESCRIPTION	150W Max	FIBRE	
VAL	3	07/12/15	CHANGED	EXTERNAL	±0.10	DESCRIPTION		FIBRE	LIGHT STONE, WHITE & BLACK FOR FURTHER DETAILS PLEASE CONTACT KELVIN HUGHES LTD
VAL	1	07/12/15	CHANGED	INTERNAL	±0.10	DESCRIPTION		FIBRE	
TOLERANCES UNLESS OTHERWISE STATED SQUARE LINEAR ±0.10 COARSE PITCH ±0.10 INTERNAL ±0.10 EXTERNAL ±0.10 HOLE DIA MP TO EN ISO 28000-11 HOLE DIA TO EN ISO 28000-11									
ALL DIMENSIONS IN MILLIMETRES UNLESS OTHERWISE STATED SQUARE LINEAR ±0.10 COARSE PITCH ±0.10 INTERNAL ±0.10 EXTERNAL ±0.10 HOLE DIA MP TO EN ISO 28000-11 HOLE DIA TO EN ISO 28000-11									

Page intentionally blank

7 Termination

7.1 Cabling and termination

CABLING

- Cabling, terminations and connections are to be made as per the latest version of IEE wiring regulations BS-7671, Requirements for Electrical Installation.
- Cables are to be of correct specification and rating and should be run in suitable cable trays or guides. They should be laid in positions that cannot cause an obstruction or hazard.
- Cable runs must allow for service loops.
- All cables should be secured in position using cable ties placed at regular intervals.
- In order to reduce electromagnetic interference effects, all cables should be routed as directly as possible, consistent with consideration for other equipment.
- Cables should not be installed close to high-power lines such as radio-transmitter lines.
- Crossing of cables should be done at right angles (90°) to minimize magnetic field coupling.
- Cables must be laid and secured in a fashion that does not place undue stress or strain on the cable or the connector. Ensure excessive strain is not applied to the cable or the connectors when connecting and disconnecting the DC power and LAN cables.
- Provision must be made on the mounting platform for securing of the cables.

MINIMUM BEND RADIUS

The minimum bend radius of the cable must be observed when laying the cable. Where a bend radius is not stated, a minimum bend radius of 12 x the cable diameter should be assumed for Kelvin Hughes Ltd supplied cable.



CORRECT

A cable correctly laid taking the minimum bend radius into account.

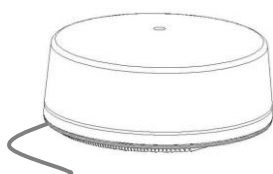

INCORRECT

Cables incorrectly laid with the bend below the minimum bend radius which places strain on the cable and connector.

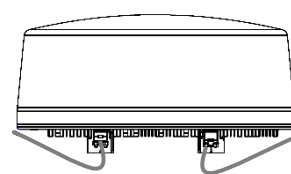

Drawings shown are for reference use only and do not represent a scaled drawing of the minimum bend radius.

CONNECTION/ CONNECTOR NOTES

- Fully isolate all sources of power to the system before mating and de-mating any connectors.
- Installation of external connectors should only be undertaken in dry conditions.
- Connectors should be inspected immediately prior to installation to ensure that pins are not bent, corroded or otherwise damaged and that no contamination, pollution or moisture has entered either mating half. Where required, cleaning should be undertaken carefully, in such a way as not to damage the contacts or insulation. For example to remove contamination and moisture compressed air spray may be used in accordance with manufacturer's and local guidance along with nylon brushes.
- The protective caps on the SCV/ SxV connectors are retained and must be left attached to the system for future use.
- The connector must never be left disconnected and exposed to the elements.
- The pre-terminated connectors are keyed to prevent incorrect connection.
- When fitted ensure each connector is fully inserted and makes a full waterproof seal.
- Ensure the cable restraining method does not strain the connector as this could cause the connector to become damaged.
- Ensure excessive strain is not applied to the cable or the connectors when connecting and disconnecting the DC power and LAN cables.

BULKHEAD AND DECK PENETRATION

Any bulkhead penetrations which are opened must be closed and sealed using appropriate materials thus maintaining existing water or fire proofing precautions.

OVERCURRENT PROTECTION DEVICES

All supplies to the system must be fitted with a suitably rated, clearly labelled overprotection device such as a breaker or a fuse.

CABLE BRACKET ASSEMBLY

The SCV-A170 cable bracket assembly used on SCV systems includes two cable clamps that must be used to restrain the cables as demonstrated opposite.



Example of a cable installed in the cable bracket assembly

CABLE CLAMP BOLTS

Lightly grease the threads of the four bolts prior to final assembly using the tube of grease provided in the fitting kit.

CONNECTOR ACCESS

Depending on the mounting arrangement, access to the two base plate connectors (LAN & DC input) is restricted when the SCV/ SxV is fully bolted to the mounting plate.

In this situation, it is recommended these connections are correctly fitted and secured *before* the main mounting bolts are fully tightened.

AC SUPPLIES

Where a mains powered AC to DC Power supply is to be connected to the system (not Kelvin Hughes standard supply), the unit must be designed in accordance with the requirements of IEC 60950-1:2005. This should include provision of a suitable rated overcurrent protective device and a protective earth connection, made to suitable earth point on the mounting platform.

The power supply should be designed in such a way that under single fault conditions mains voltages cannot be applied to its DC output.

MATING/ DE-MATING

The connectors are a keyed Push-Pull latching connector that can only be inserted in one orientation into the correct mating half.

To remove the connectors pull the collar back with minimal force to release the connector, then pull with minimal force. Correct mating and de-mating of the connector requires very little force. If effort is required when connecting or disconnecting connectors, the wrong technique is being employed.

7.2 DC input

SCV-A167-** Note 1 & Note 2

A pre-terminated cable can be supplied for connecting the DC input to PL1 located on the base of the SCV/ SxV radome radar.



CABLE LENGTH

Standard systems typically use 10 metres of cable however other cable lengths are available as detailed below.

Part No. <small>Note 2</small>	Length (mm)
SCV-A167-05	5000
SCV-A167-10	10000
SCV-A167-15	15000
SCV-A167-20	20000
SCV-A167-25	25000
SCV-A167-30	30000

Any additional cabling required for connecting the system to the DC power, breakers etc. should be of a sufficient gauge to ensure that the minimum voltage required by the SCV/ SxV is maintained under the worst case load conditions (see section 13.3).

CABLE TYPE

LSZH 3x14AWG Screened. Diameter approx. 11mm.

CONNECTOR TYPE

Fischer UltiMate UP01L13 F303S BK1 Z1ZB (SCV/SxV Mating half UR02W13 M303S BK1 E1AB)

DC POWER SOURCE

The SharpEye™ SCV/ SxV series has been designed to run from a +24VDC to +30VDC supply, with +28VDC being used in typical installations.

For longer cable runs higher DC supply voltages are recommended. Please refer to section 13.3 for details and full electrical specifications.

WARNING

The SCV/ SxV must not be connected directly to an unprotected/ un-switched DC power source. Isolate all of DC power to the system before mating or de-mating the connectors.

NOTICE

Connectors should be inspected prior to connection to ensure there are no foreign object or damage to the connector.

Note 1: Where -** is the length of the cable in metres.

Note 2: SCV variant SCV-A1-10-ADAC should be ordered with power cable SCV-A177-** rather than SCV-A167-**.

Please contact Kelvin Hughes Ltd if alternative cable assemblies are required.

Note 3: DC circuit breakers and switches are not supplied.

SharpEye™ SCV & SxV X-Band Radome Radar
Chapter 7: Termination

DC BREAKER

There is no ON/ OFF switch on the SharpEye™ SCV or SxV radome radar. The DC supply to the radome radar must be connected via a suitable rated user accessible DC breaker. See section 13.3 for the breaker rating. ^{Note 3}

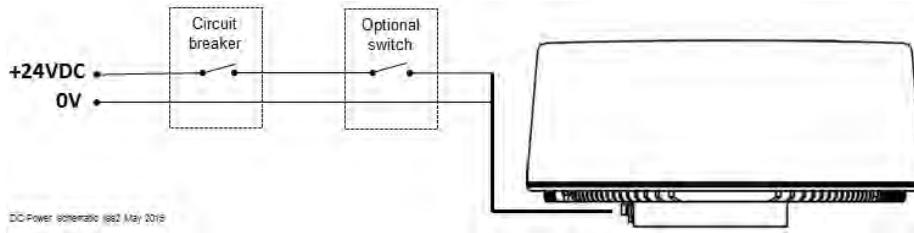

EXAMPLE OF DC POWER CABLE



CONNECTION DETAILS

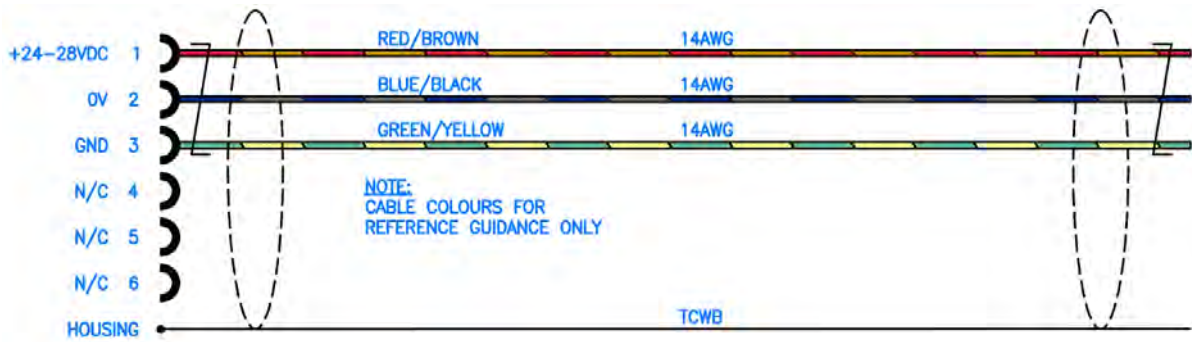

DC CONNECTOR PIN ORIENTATION

Viewed from the back/ soldering side

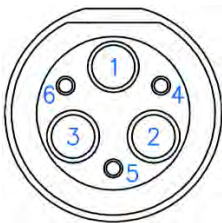

SharpEye™ SCV & SxV X-Band Radome Radar
Chapter 7: Termination

7.3 LAN input

SCV-A168- Note**

A pre-terminated cable is available for connecting the LAN cable to the connector located on the base of the SCV/ SxV radome radar.



CABLE LENGTH

Standard systems typically use 10 metres of cable however other cable lengths are available as detailed below.

Part No.	Length (mm)
SCV-A168-05	5000
SCV-A168-10	10000
SCV-A168-15	15000
SCV-A168-20	20000
SCV-A168-25	25000
SCV-A168-30	30000

CABLE TYPE

LSZH Cat 5e S/FTP. Diameter 8mm approx.

CONNECTOR TYPE

Fischer UltiMate UP01L11 M012S BK1 Z1ZB (SCV/SxV Mating half UR02W11 F012S BK1 E1AB)

EXAMPLE OF LAN CABLE



CONNECTION DETAILS



LAN CONNECTOR PIN ORIENTATIONS

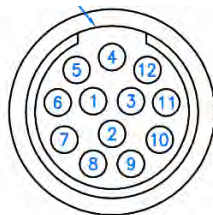

SCV connection
Viewed from the back/ soldering side

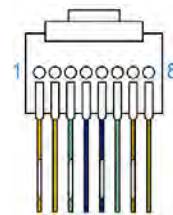

RJ45 connection
viewed from front

Note: Where -** is the length of the cable in metres.

7.4 Ground/ Earth cable

SCV-A145 EARTH BONDING CABLE

The earth strap supplied in the fitting kit **MUST** be used to fix the SCV/SxV to a proven earth point on the mounting platform using the fixings supplied with the unit.

CABLE LENGTH

250mm long.

Other cable lengths are available, Please contact Kelvin Hughes Ltd for further details.

CONNECTION

The SCV/SxV is grounded via the M6 earth stud located on the base of the SCV/SxV which should be connected to a tested/ proven ground point.



For EMC/ interference reasons, Kelvin Hughes Ltd recommend that the earth/ ground connection is always connected to the common platform chassis ground.

NOTICE

The ground/ earth termination **MUST BE MADE** using the SCV-A145 cable supplied in the fitting kit
 Please contact Kelvin Hughes Ltd if alternative grounding arrangements are required.

BATTERY CONNECTION

SxV systems powered by a battery do not require an earth connection.

CABLE DETAILS

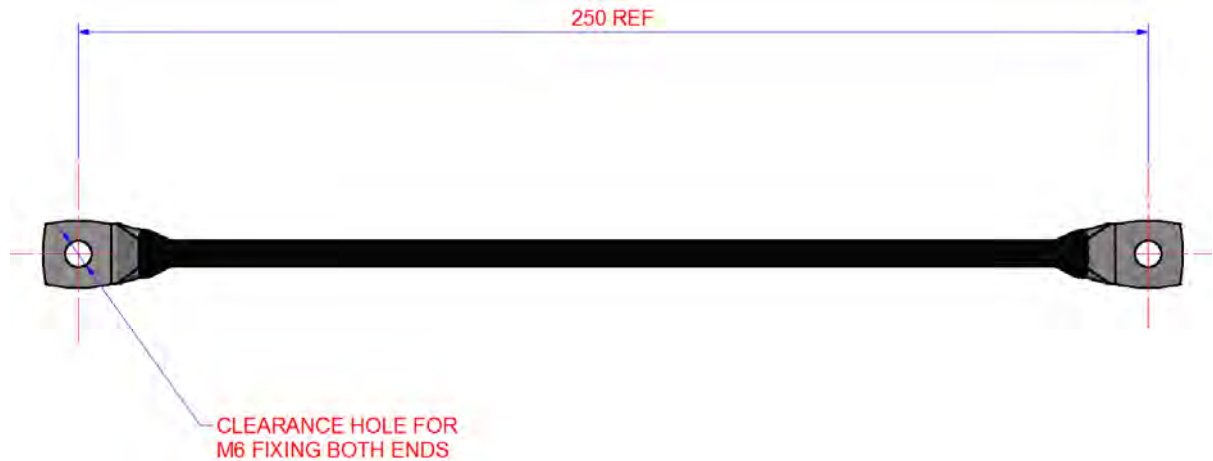

Example of standard SCV-A145 cable

CABLE SPECIFICATION

Cable Length	Conductor CSA (mm ²)	Stud size ref.	Hole Ref. (diameter)	Lug width	Lug thickness	Current rating
250 ^{Note}	15	M6	6.4	15.5	2.2	120A

SharpEye™ SCV & SxV X-Band Radome Radar
Chapter 7: Termination

M6 EARTH STUD ASSEMBLY

The strap and washers should be assembled as shown below.

When the earth strap has been secured, the surfaces should be lightly covered in the anti-corrosion paste supplied as part of the fitting kit. This paste protects the connection against water ingress and corrosion.

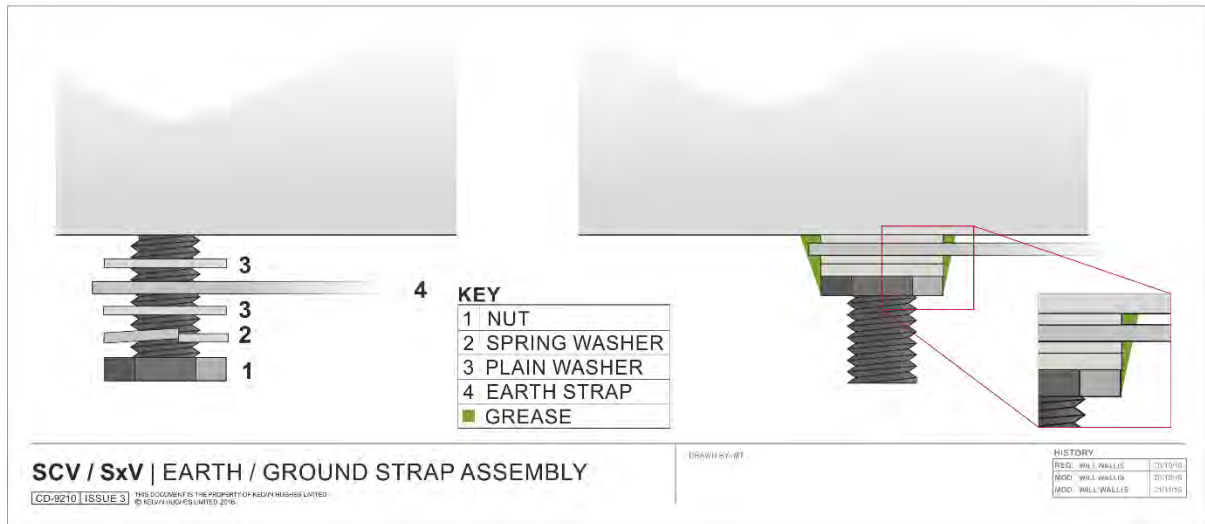

In addition, Denso tape or a suitable self-amalgamating tapes may be used to protect the connection/joint from corrosion.

CONDUCTIVITY TESTING

Once fitted, the earth bonding should be measured to ensure good conductivity is achieved. See Section 11: Planned maintenance for the correct test procedure.

SharpEye™ SCV & SxV X-Band Radome Radar
Chapter 7: Termination

7.5 CONNECTION DIAGRAM

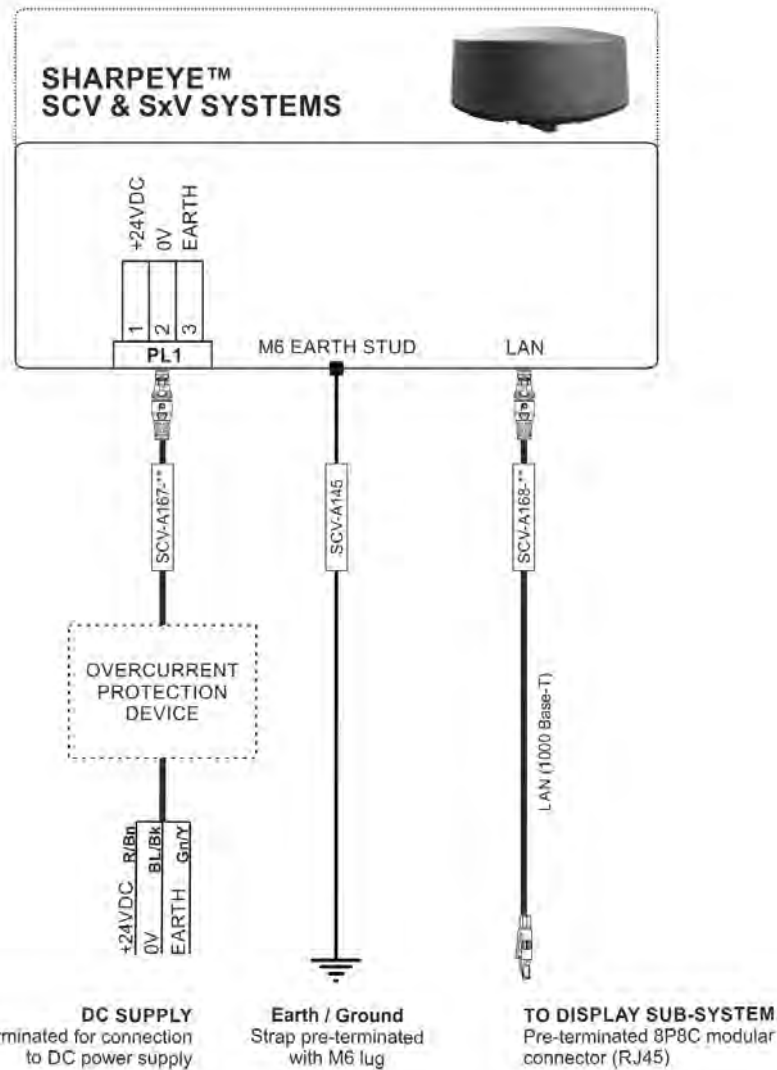

NOTE: WHERE -** IS THE LENGTH OF THE CABLE IN METRES

NOT KELVIN HUGHES SUPPLIED

SharpEye™
SCV & SxV CABLE TERMINATION

CD-8921 | ISSUE 4 | THIS DOCUMENT IS THE PROPERTY OF KELVIN HUGHES LIMITED © KELVIN HUGHES LIMITED 2016

HISTORY

REQ.	WILL WALLIS	20/10/16
MOD.	WILL WALLIS	20/10/16
MOD.	*****	20/10/16
MOD.	*****	20/10/16

CABLE DEATILS

Further details on the cables shown in the above diagram can be found in the following sections of this handbook.

- DC input cable: See section 7.2
- LAN Connector and cable: See section 7.3
- Earth Strap: See section 7.4
- Longer DC power cables: See section 13.3

8 Commissioning

8.1 Overview

THE SCV/ SXV IS SHIPPED PRE-CONFIGURED

In most applications no commissioning is required as the system is configured via the display sub-system. Please contact Kelvin Hughes Ltd where advanced commissioning is required.

COMPUTING EQUIPMENT

Where commissioning of the transceiver is required, it will be necessary to connect a laptop computer to the SCV/ SxV.

Please refer to the anti-virus warnings in the health & safety section located at the beginning of this handbook prior to connecting any computing equipment to the SCV/ SxV.

The procedures noted in this handbook do not detail the configuration of firewall or antivirus software on a laptop computer. Kelvin Hughes can only offer technical assistance with the parameters directly related to the configuration of the SCV/ SxV.

CAUTION

IP ADDRESS

The setting to work/ commissioning web page contains the SCV/ SxV IP addresses. Unless specifically instructed the IP addresses MUST NOT be changed. Incorrect configuration of the IP addresses can render the system un-operational.

IP ADDRESS RECORD

Where an IP address is changed, record the addresses below:

OLD IP address (for reference use)	
NEW IP address	

BEARING ADJUSTMENT/ RANGE ALIGNMENT

Bearing adjustment of the video such as heading adjustment, frequency skew correction and azimuth adjustment due to selected range mode is calibrated using the display sub-system. This cannot be adjusted or commissioned at the SCV/ SxV. Please refer to the system commissioning handbook for the display sub-system for instructions.

SYSTEM INTEGRATION

Additional details on system integration are available upon request. Please contact Kelvin Hughes Ltd for information. Contact details can be found at the end of this publication.

COMMISSIONING SETTINGS

Commissioning settings are stored in non-volatile memory within the unit. The settings cannot be backed up so a manual record of all settings must be made in the relevant section of the handbook.

SharpEye™ SCV & SxV X-Band Radome Radar

Chapter 8: Commissioning

8.2 Commission web page

In most applications it will not be necessary to access this page. Parameters within the web page must only be adjusted when specifically advised by Kelvin Hughes Ltd or as part of a system integration instruction document.

When access to the commission pages is required, connect a laptop computer to the LAN connection of the SCV/ SxV system. The connection can be made using the LAN cable supplied with the equipment (see Computing Equipment in the previous page).

The SCV/ SxV commissioning web page can be accessed by opening a web browser and entering the following IP address: <http://192.168.22.70:8008>

SCV Configuration

Compass Settings

Compass declination: (degrees)

Compass Readings

Module status: OK

Raw magnetic reading: 186.4 degrees

Adjusted reading: 17.5 degrees.

Raw pitch/roll: 0/-1

Adjusted Pitch/roll: -0.2/1.0

Motion Compensation

Using external motion data source (internal is disabled)

NMEA Output parameters

Target IP address:

Target UDP port:

Source UDP port: 0. (0 is auto-assigned) [Change](#)

Enable output stream

GPS Module status: OK

Current GPS Signal Quality: '3' 1, 0, 1

Required NMEA Message categories:

- GGA
- GLL
- GSA
- GSV
- RMC
- VTG
- ZDA
- DTM, GNS, THS, and Others
- HDG (compass)
- XDR (pitch/roll)

IP parameters

IP address:

Subnet mask:

Default gateway:

Video multicast address:

Status multicast address:

NTP server address:

Advanced IP parameters

Master Control TCP port: 6744.

Slave Control TCP port: 6745.

Video source UDP port: 6743.

Video destination UDP port: 6718.

Status source UDP port: 6747.

Status destination UDP port: 6747.

NTP port: 123.

Multicast TTL: 10

Control port mode: Multi Master Single Master

[Change Advanced IP parameters](#)

Asterix parameters

SAC: decimal (0-255)

Timestamp enabled

Blank Video for Blanked Sectors

SIC: decimal (0-255)

Video Amplitude resolution: 4 bits 8 bits 16 bits

Example of SCV/ SxV commissioning web page.

8.3 Compass Settings

INTERNAL COMPASS.

The SCV/ SxV is supplied with an internal compass that can be enabled as part of the system integration. When enabled, NMEA messages are output within the UDP packets.

Where the internal compass is enabled and in use, the compass must be calibrated to eliminate any errors caused by magnetic materials within the installation.

NOTICE
 The following tests will require the platform to be manoeuvred into different positions / directions to calibrate the internal compass.

Set up	<p>With the DC supply to the system switched OFF, connect the SCV to a virus free laptop computer. The connection can be made using the LAN cable supplied with the equipment.</p> <p>Switch ON the DC supply to the system.</p> <p>During the configuration of the system, It is necessary for the GPS to have an unimpeded view of the sky and be free from electromagnetic interference at GPS frequencies.</p>	
Open Web page	<p>On the laptop PC, open an internet browser and enter the following address: 192.168.22.70:8008</p> <div style="display: flex; justify-content: space-between;"> <div style="width: 45%;"> <p>Compass Settings</p> <p><input type="button" value="Start Compass Calibration"/></p> <p>Compass declination: <input type="text" value="-1.0"/> (degrees)</p> <p><input type="button" value="Set compass declination"/></p> </div> <div style="width: 45%;"> <p>Compass Readings</p> <p>Module status: OK</p> <p>Raw magnetic reading: 186.4 degrees</p> <p>Adjusted reading: 17.5 degrees</p> <p>Raw pitch/roll: 0/-1</p> <p>Adjusted Pitch/roll: -0.2/1.0</p> </div> </div>	
Record current values	Record the Compass and GPS Module Status shown on the web page.	<p>Compass:</p> <hr/> <p>GPS:</p>
Start Compass Calibration	<p>Click on the Start Compass Calibration button and follow instructions on the web interface. It will be necessary for the platform to be rotated or manoeuvre in a complete circle, through North, South East and West. The radius of the circle is unimportant.</p>	
Compass Declination	<p>If known, set the Compass Declination.</p> <p>Notes: Magnetic declination or variation is the angle on the horizontal plane between magnetic north and true north. This angle varies depending on position on the Earth's surface, and changes over time. If the position of the vessel changes substantially from the location it was last calibrated in, this process should be repeated.</p> <p>Where the SCV/SxV is connected to a display system and is using a suitably accurate GNSS, Log and Gyro providing regular messages at a suitable rate, it may be preferable to us the check "Using external motion data source" where the SCV/ SxV uses the external data rather than the internal compass. This should be assessed by the service agent performing the procedure, please contact Kelvin Hughes Ltd for further details.</p>	
	<p>Record the Compass Declination value:</p>	

8.4 Blind sector, heading line offset record

To determine the blind arcs where the vessel superstructure may block the transmitted RF radiation, identify a strong target on the display and then manoeuvre the vessel or platform in a clockwise circle.

Note the 'start bearing' where the target is no longer visible and the 'stop bearing' where the target becomes visible again. There may be multiple blind arcs. Use 'Head-up' mode on the display.

Any heading line offsets or blind (mute) sectors that are configured for the system must be recorded on the following diagram.

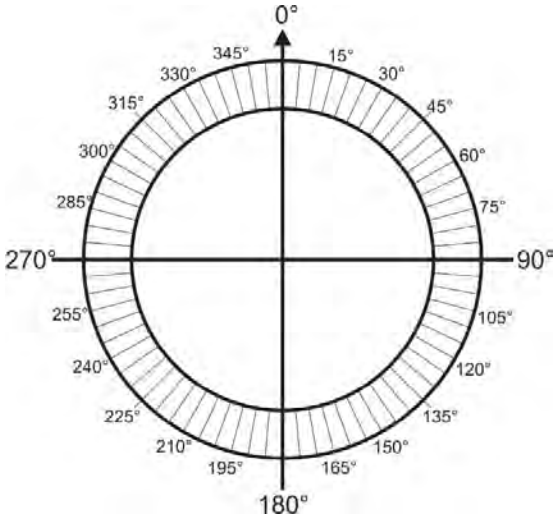
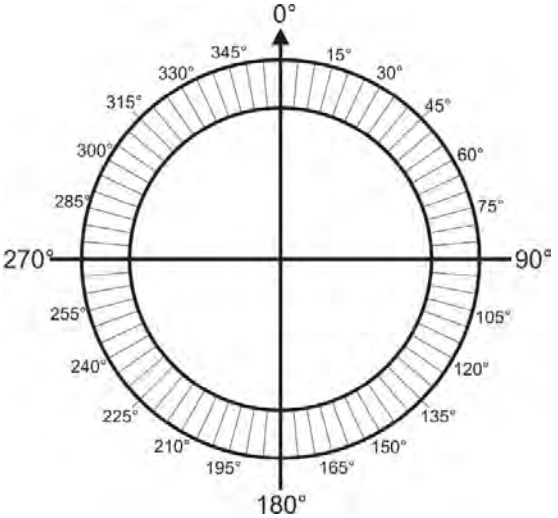
	
<p>Description:</p>	<p>Description:</p>

9 Completion of installation

9.1 Installation checks

On completion of an installation the following tasks must be carried out.

TASK		Confirmed
Fastenings	Ensure that all fastenings are correctly and securely tightened to the correct torque setting (where specified).	<input type="checkbox"/>
Anti-vibration mounts	On SCV systems ensure that the SCV-A172 anti-vibration mount and SCV-A170 cable bracket assembly are correctly fitted.	<input type="checkbox"/>
Connectors	Ensure all connectors are correctly and securely fitted.	<input type="checkbox"/>
Cabling	Check that all cables are safety restrained, cannot present a hazard and that the cables do not place undue strain on connectors.	<input type="checkbox"/>
Ground/ Earth	Test the impedance of the grounding/ earth connection between the SCV/ SxV and the platform ground. For the test procedure, please refer to the Earth bonding and continuity tests detailed in the planned maintenance section (section 11).	<input type="checkbox"/>
Testing	Where possible, confirm the SCV/ SxV is fully operational prior to handing the system over to the customer.	<input type="checkbox"/>
Clear the working area	Ensure that all unused materials such as unused cables, wire cuttings etc. are tidied away and are safely disposed of. All working areas used shall be left clean and tidy.	<input type="checkbox"/>
SCV/ SxV Packing/ transit case	The main packing case (Part No. PP-7226) used to deliver the SCV or SxV must be retained. This case must be re-used if returning a unit to Kelvin Hughes. All other packaging should be disposed of in accordance local regulations.	<input type="checkbox"/>
Warranty card	On completion of an installation the warranty card must be completed and returned to Kelvin Hughes Ltd; postal details are shown on the warranty card. ALL relevant sections of the warranty card check list must be completed. If an inspection on the warranty card checklist is NOT ticked it is assumed that the installation engineer has NOT carried out the inspection. Costs incurred due to attendance to repair incorrect or uninspected installations will be forwarded to the company responsible for the failure to correctly perform the work.	<input type="checkbox"/>

NOTES

Connectors, straps and fixings should be protected against corrosion using either suitable Denso products (or equivalent) or suitably specified halogen free, non-silicone based self-amalgamating tape that is intended for outdoor use (UV & Ozone stabilized) and in the case of SCV system a marine environment. Manufacturer's instructions should be reviewed for suitability prior to application.

Damage to finishes or metalwork should be made good immediately.

Any damage that has occurred, including accidental dropping of the unit, must be reported to Kelvin Hughes Ltd before the unit is installed or operated.

TESTING NOTES

Blanking sectors should be set via the display sub-system to ensure that the SCV/SxV does not transmit into ships superstructure or an object that could potentially generate false radar returns (see section 8.3). Similarly, any Heading Line skew adjustment should be set using the display sub-system.

9.2 Warranty

WARNING

DO NOT DISMANTLE THE SCV/ SXV RADOME RADAR

SharpEye™ SCV and SxV systems are **factory sealed** units that contain no field serviceable, user adjustable or repairable parts. Access to components or sub-assemblies within the system is NOT required during system installation, commissioning, maintenance or operation.

Opening the unit breaks the tamper and waterproof seals. Such action voids the warranty status of the unit. Please refer to Kelvin Hughes Ltd for a full list of warranty terms.

TRANSIT CASE

If the SCV or SxV is to be returned to Kelvin Hughes Ltd or is to be transported for any other reason, the unit must be securely packed in an upright position using the original transit packing case and its foam inserts as supplied with the equipment.

Prior to use, the packing case should be examined to ensure that it is undamaged.

If the transit/ packing case has been lost or is damaged please contact Kelvin Hughes Ltd. The transit packing case part number is PP-7226.

10 Operator instructions

10.1 Switch ON and OFF

Switch ON: There is no ON/ OFF power switch on the SCV or SxV radome radar.

As soon as DC power is applied to the system via the external breaker or an external ON/ OFF power switch, the system enters a 30 second boot-up period during which time the SharpEye™ processor initiates and carries out a number of self-checks. After this time the system is available for use.

Switch OFF: To switch the radome radar OFF, place the system into Standby and isolate the system from the DC supply using the external breaker or external ON/ OFF power switch.

Indicators: There are no power or status indicators on the SCV/ SxV system itself.

10.2 Control

LAN and NETWORK SWITCHING

The SharpEye™ SCV and SxV systems are both controlled via a Gigabit Ethernet LAN from an external command and display system.

- Radar video data (CAT240 ASTERIX), BITE data and system status messages are sent from the radome radar to the command and display system via LAN. Radar data is typically high bandwidth data and as such requires a Gigabit Ethernet network
- Control signals are received by the radome radar via the same Ethernet cable.
- Any switches used with the SCV/ SxV must support Gigabit Ethernet (1000 Base-T) and IGMP snooping.

SCV/SxV OPERATOR CONTROLS

There are no operator controls or user functions located on or within the radome radar itself.

KELVIN HUGHES DISPLAY CONTROL

For Kelvin Hughes systems please refer to the following handbooks:

- MantaDigital™ systems: HBK-4001-1
- Kelvin Hughes Navigation Display: HBK-2300-1
- CxEye integrated mast camera systems: NCD-22590

The operation of third party external command & display systems are not detailed in this handbook. Please refer to the manufacturer's operator handbooks supplied with the equipment for instructions.

10.3 Elevation beamwidth

Due to the beamwidth of the antenna, target detection will be significantly reduced if the SCV/ SxV assembly is tilted by more than 12.5° from horizontal/ flat.

10.4 Performance monitoring

The SharpEye™ transceiver processor fitted within the factory sealed unit constantly monitors the system's performance and will advise operators through warnings and alarms of any errors or performance related issues.

SharpEye™ SCV & SxV X-Band Radome Radar
Chapter 10: Operator instructions

10.5 Operational states

The following tables shows the basic operation states for the SharpEye™ SCV or SxV radome radar

Operational mode	Description
OFF	DC power is OFF.
	<ul style="list-style-type: none"> The system is switched OFF and cannot be operated. No data is sent via LAN.
Switch ON/ Standby	DC power is ON No RUN command is being received.
	<ul style="list-style-type: none"> At initial power up the system enters a 30 second initialisation period. The SharpEye™ processor carries out internal performance checks. After the initialisation period the system enters a standby state waiting for a RUN command via LAN from the external command and display system. The SharpEye™ processor continues to monitor the system performance. System warnings and BITE data are sent via LAN to the external command and display system. If a system critical condition is detected, a warning is sent via LAN to the external command and display system and the system cannot be placed into Run mode.
RUN	DC power is ON. A RUN command has been received.
	<ul style="list-style-type: none"> The system starts transmitting. Radar data is sent to the external command and display system via the LAN. The SharpEye™ processor continues to monitor the system performance. System warnings and BITE data are sent via LAN to the external command and display system. If a system critical condition is detected, a warning is sent via LAN to the external command and display system and the system reverts to standby.
Low Power Mode	DC power is ON. A RUN command has been received.
	<p>Operator selected: When the SCV/ SxV radome radar is connected to a processor/ display option that supports radar radome configuration, Low Power Mode can be selected for counter surveillance or covert operation.</p> <p>Fault mode: Should the radome radar detect an internal fault condition which could lead to early failure of the transceiver, i.e. a high VSWR, then the transceiver switches to a Low Power state which permits low power transmission to continue in the short term.</p> <p>The built in test monitoring also outputs a “Low RF Power” warning message if the RF power output falls below 12 W. The design is “fail-soft” thereby providing graceful degradation in the event of single or multiple transistor failures.</p> <p>As a result of reduced output power, range performance will be reduced and the system may not meet the expected operational detection performance.</p>
Fault Mode	DC power is ON.
	<ul style="list-style-type: none"> A RUN command has been received. The system has detected an internal processor fault condition and cannot be operated. See corrective maintenance for rectification action.

SharpEye™ SCV & SxV X-Band Radome Radar
Chapter 10: Operator instructions

Operational mode <small>Note</small>	<i>Description</i>
Power Modes	<p>Low / High power can be selected.</p> <p>Low power may be used in close waters or in a high clutter environment where a high output power may produce excessive unwanted reflections from buildings, bridges and vessels.</p> <p>The transceiver will utilise the frame pattern for the selected range mode but with the output power reduced from the nominal 80W (49dBm) to approximately 12W (typical) 39.5 to 42.5dBm.</p>
	CAUTION
	<p style="text-align: center;">As a result of reduced output power, range performance will be reduced.</p>
	<p>When low power is selected, a low power status is automatically generated to advise the operator that the system is operating at a reduced output power.</p> <p>Where the SharpEye™ detects a VSWR or a high temperature within the transceiver the system automatically switches to low power mode and generates system alarms.</p>
Available frequencies	<p>9 channels are available at 9.22 to 9.38 GHz in 20MHz steps.</p>
Range Mode	<p>6, 12 and 24NM range modes can be selected</p> <p>These provide continuous video from the SCV/ SxV's minimum range out to the stated range.</p> <p>Each mode utilises slightly different processing and different pulse patterns. It is generally preferable for the operator to use the lowest range mode which provides sufficient range for the task they are trying to achieve.</p> <p>In some instances additional radar modes are available, please contact Kelvin Hughes Ltd for further information.</p>
BIT (Built in Test) status	<p>Depending on the communications interface in use, BIT data may be available indicating the status of the SCV/ SxV.</p> <p>A list of BIT data is available from Kelvin Hughes upon request.</p>

Note: Selection and control of the modes described above is dependent on the display sub-system compatibility with the SCV/ SxV.

Page intentionally blank

11 Planned maintenance

This section provides information on the recommended maintenance tasks for the Kelvin Hughes Ltd SharpEye™ SCV & SxV transceiver systems.

HEALTH AND SAFETY

All Health & Safety warnings noted at the beginning of this handbook must be observed at all times when inspecting the system.

ADVERSE WEATHER CONDITIONS

It is recommended that the mounting bolts inspections are carried out at the earliest safe opportunity after the system has been exposed to severe or adverse weather conditions, high impacts or severe vibrations.

ISOLATE THE SYSTEM

Prior to carrying out any system inspection or maintenance procedure, the system must be fully isolated from the DC supply using the external DC breaker.

DO NOT DISMANTLE THE RADOME

SharpEye™ SCV and SxV systems are factory sealed units that contain no field serviceable or repairable parts. Access to components or sub-assemblies within the system is NOT required during installation, maintenance or operation. Opening the unit breaks tamper and waterproof seals and voids the warranty status of the unit.

WARNING

CASING TEMPERATURE

When the system has been operating in strong sunlight or elevated temperatures, the casing surfaces may be extremely hot.

At ambient temperatures exceeding +50°C, the SCV/ SxV baseplate temperature can exceed +70°C.

MAINTENANCE RECORD

This section has been designed to be printed, completed and retained as a maintenance record.

Please contact Kelvin Hughes Ltd for instructions is one of the tests detailed in the above procedures fails.

MAINTENANCE PROCEDURES

Isolate the system:

Prior to carrying out any maintenance, the system must be fully isolated from the DC supply using the external DC breaker.

Carry out the maintenance tasks:

The required maintenance tasks should be undertaken.

Restore power and test.

On completion of the maintenance tasks, the power should be restored and the system fully tested.

Any damage that is identified as part of an inspection should immediately be reported to Kelvin Hughes Ltd and appropriate action taken to prevent further damage occurring.

SharpEye™ SCV & SxV X-Band Radome Radar
Chapter 11: Planned maintenance

ROUTINE MAINTENANCE SCHEDULE

The scheduled for routine maintenance will vary depending on the application and location of the equipment as indicated below:



ROUTINE PLANNED MAINTENANCE RECORD SHEET		
Task	Description	Passed
Cleaning	Ensure the radome is clean and free from dirt. As necessary Clean the radome with a soft cloth moistened in a mild non-abrasive alcohol free soap solution.	<input type="checkbox"/>
Physical inspection	Ensure that all fasteners retaining the system are tight, are secure and show no signs of damage. <small>Note 1</small>	<input type="checkbox"/>
	Ensure that the DC power and LAN connections are securely connected and restrained.	<input type="checkbox"/>
	The system should be checked to ensure there is no obvious external damage, cracks or splits in the housing or potential fault conditions that could lead to a general failure of any part of the system. <small>Note</small>	<input type="checkbox"/>
Earth bonding and continuity	Ensure that the earth bonding nuts and bolts are tight and free from corrosion. If corrosion is present, clean and re-terminate. <small>Note</small>	<input type="checkbox"/>
	Test the earth bonding conductivity by attaching one lead of the test equipment to earth/ chassis and the other to the M6 earth stud on the radome radar. <small>Note 2</small> Check earth bonding for continuity. The resistance should not exceed 0.1 ohms. If a test fails, investigate the bonding, rectify and retest.	<input type="checkbox"/>
Inspected By	Name print & sign	
Date (dd/mm/yyyy)		

Note 1: Over time, some white discolouration of the fasteners provided in the fitting kit is normal. This is due to the sacrificial zinc plating and not an indication of the stainless steel bolt rusting.

Note 2: Safety ohmmeter, bridge Megger or Multimeter for testing the earth bonding.

SharpEye™ SCV & SxV X-Band Radome Radar
Chapter 11: Planned maintenance

3-MONTHLY PLANNED MAINTENANCE RECORD SHEET				
System	SharpEye™ SCV	<input type="checkbox"/>	SharpEye™ SxV	<input type="checkbox"/>
Serial number				
Inspection date	(dd/ mm/ yyyy)			
Inspected by	<i>Print:</i>	<i>Sign:</i>		
Tools required	Mild non-abrasive alcohol free detergent Soft abrasive free cloth Safety ohmmeter, Bridge Megger or multimeter			
Skill level	Basic electrical training, good understanding of Health & Safety practices			
Inspection time	Less than 30 minutes depending on equipment location and accessibility.			
Task	Description	Pass	Fail	
Cleaning	Clean the radome with a soft cloth moistened in a mild non-abrasive alcohol free soap solution. <i>Cleaning the radome is important as system performance can be degraded if the transmission face becomes obscured by salt deposits or dirt. The radome must never be painted.</i>	<input type="checkbox"/>	<input type="checkbox"/>	
	Ensure that all fasteners retaining the system are tight, secure and show no signs of severe corrosion or damage.	<input type="checkbox"/>	<input type="checkbox"/>	
Physical inspection	Inspect the system including the mounting points and (where fitted) the anti-vibration mounts for <i>any</i> signs of stress damage. Adverse conditions: <i>This inspection should be carried out at the earliest safe opportunity after the system has been exposed to severe or adverse weather conditions, high impacts or severe vibrations.</i>	<input type="checkbox"/>	<input type="checkbox"/>	
	Check that the DC power and LAN cable connections are securely fastened and appear to be watertight.	<input type="checkbox"/>	<input type="checkbox"/>	
	Check all accessible or exposed cables for signs of damage and ensure they are safely secured into/ onto cable trays or trunking.	<input type="checkbox"/>	<input type="checkbox"/>	
	Check that the Immersible breather located on the base of the transceiver is clean and not obscured by dirt. Caution: <i>Do not insert sharp or pointed objects into the immersible breather as this will damage the seal.</i>	<input type="checkbox"/>	<input type="checkbox"/>	
	The system should be checked to ensure there is no obvious external damage, cracks or splits in the housing or potential fault conditions that could lead to a general failure of any part of the system.	<input type="checkbox"/>	<input type="checkbox"/>	
Earth bonding and continuity	Ensure that the earth bonding nuts and bolts are tight and free from corrosion. If corrosion is present, clean and re-terminate	<input type="checkbox"/>	<input type="checkbox"/>	
	Test the earth bonding conductivity by attaching one lead of the test equipment ^{note} to earth/ chassis and the other to the M6 earth stud on the radome radar. Check earth bonding for continuity. The resistance should not exceed 0.1 ohms. If a test fails, investigate the bonding, rectify and retest. Note: Safety ohmmeter, Bridge Megger or Multimeter.	<input type="checkbox"/>	<input type="checkbox"/>	

Page intentionally blank

12 Corrective maintenance

Fault finding the SharpEye™ SCV and SxV radome radar is limited to:

- Resetting the system
- Ensuring that the DC input voltage is within acceptable limits
- Troubleshooting using the procedures noted in this section of the handbook.

There are no external power or status indicators on the radome radar.

DO NOT DISMANTLE THE SCV/ SxV RADOME RADAR

SCV and SxV systems are factory sealed units that contain no field serviceable or repairable parts. Opening the unit breaks tamper and waterproof seals and voids the warranty status of the unit.

12.1 System reset

In the unlikely event of a system freeze, system lock up or an error message, the system may need to be reset as follows:

SWITCH TO STANDBY: Where possible switch the system to standby using the external command and display system.

SWITCH OFF: Using the external breaker or external ON/ OFF power switch, isolate the DC power to the system and leave in an unpowered state for approximately 1 minute. This allows for any residual power in the system to drain away.

SWITCH BACK ON: Using the external breaker or external ON/ OFF power switch restore the DC power to the system and test.

If the fault condition persists please contact Kelvin Hughes Ltd for assistance.

12.2 Repair and return

The SCV/ SxV radome radar is a Line Replacement Unit that contains no field serviceable or repairable parts. The complete sealed radome radar must be returned to Kelvin Hughes for analysis.

In line with our product returns policy, If the SCV or SxV is to be returned to Kelvin Hughes Ltd or is to be transported for any other reason, the unit must be securely packed in an upright position using the original transit packing case and its foam inserts as originally supplied with the equipment.

Prior to use, the packing case should be examined to ensure that it is undamaged. If the transit/ packing case has been lost or it is damaged, please contact Kelvin Hughes Ltd.

12.3 Troubleshooting

<p>Loss of video</p> <p>and/ or</p> <p>Loss of status messages</p>	<p>If video ceases to be displayed and the SCV/ SxV is installed in a position where a person can be within 15m of the antenna, as a precautionary measure the operator should cease transmission immediately and investigate the problem.</p> <p>Transmission can be stopped by switching the SCV/ SxV system OFF. This ensures that if the antenna has ceased rotation under fault conditions in such a position that it is facing a person and further software faults occur, nobody is accidentally irradiated in excess of the safe limits.</p> <p>If the system fails to communicate after the initialisation period, isolate the power to the system and ensure that both the DC and LAN cables are securely connected and free from damage.</p> <p>Check that the DC voltages being supplied to the system are within acceptable limits. If the system randomly resets or is temporarily unavailable, check that the DC input to the system is stable <i>under load conditions</i> and does not drop below the recommended minimum DC input level noted in section 13.3.</p> <p>Standard network diagnostic tools and software may be used to ensure data is being output from the SCV LAN connection. If the system operates on a network, try connecting the SCV directly to the display from the LAN cable or diagnostic tools.</p>
<p>System showing Video and/ or status messages but, interference or poor returns are present on the display sub-system</p>	<p>Ensure that there are no objects in the immediate vicinity of the system that may be blocking or reflecting RF radiation back towards the radome. If this is unavoidable, ensure that a blanking sector has been correctly configured to cover the affected area (please refer to section 4 regarding blanking sectors).</p> <p>It may be necessary to cover the objects with Radar Absorbent Material (RAM) to attenuate unwanted reflections.</p> <p>Where the display software permits:</p> <ol style="list-style-type: none"> 1. Change the SharpEye™ transmission frequency. If the problem disappears it may be being caused by interference from other transmitters in the local vicinity. 2. Change the SharpEye power from High to Low power. Return the system to High power on completion of any tests. 3. Mute the system on each available range mode and see if any interference remains on screen. If a mute feature is not available, set a blanking sector that covers the area of interference or the whole display are (i.e. 360°).
<p>Fault reporting</p>	<p>If a problem persists and cannot be resolved, please contact Kelvin Hughes Ltd with the following details:</p> <ol style="list-style-type: none"> 1. FAULT CONDITION: Describe the condition being experienced, the modes or control commands that cause the issue and any error messages that have been observed. 2. BIT DATA: If the communications interface in use can display BIT data from the SCV/ SxV, please advise the messages being displayed. A full list of BIT data is available from Kelvin Hughes upon request. 3. SCREEN GRABS: Where permissible and where the display software permits, take screen shots of the display showing the affected video. If there is no screen grab facility take a photograph or a short video. Photographs or diagrams of the installation, where permissible, may also prove useful. 4. INTERFERENCE: If the issue relates to an object that cannot be observed on screen, describe the object, its distance from the radar and any other conditions (e.g. metrological) that may have an impact on target detection.

SharpEye™ SCV & SxV X-Band Radome Radar
Chapter 13: Specifications

13 Specifications

13.1 Mechanical specifications

Dimensions	SCV	586mm Ø x 338mm high (includes anti-vibration mounts and cable bracket)
	SxV	586mm Ø x 292mm high
Weights	SCV	SCV-A1-10-****: 20kg approximately SCV-A170 cable bracket: 421g SCV-A172 Anti-Vibration mount: 2Kg
	SxV	20kg approximately
	Packing case	11Kg approximately (packing case part No. PP-7226)
Radome colour	Black as standard but other colours such as white, sand and olive can be obtained by special order	

13.2 Environmental specifications

Operating Temperature	-25°C to +55°C ambient temperature including solar heating Up to 95% relative humidity at +40°C Note: At low temperatures it is recommended the Radome radar is left powered in standby or RUN mode.	
EXTENDED Operating Temperature	-25°C to -40°C	WARNING The radome radar must remain switched ON in standby or RUN mode when exposed to or operating at temperatures between -25°C to -40°C. It is recommended that systems that are switched OFF and exposed to temperatures between -25°C to -40°C are not switched ON or operated until the unit has returned to temperatures above -25°C for 8 hours or more.
Storage Temperature	-40°C to +70°C Up to 95% relative humidity at +40°C	
Storage & Packing	Equipment being stored prior to installation or delivery must be kept in its original packing. When opened or after any inspection all equipment must be repacked in an upright position using the original packing material supplied by Kelvin Hughes Ltd. Shipping clearances and Special Packing Instruction conditions may be void if the equipment is unpacked. <small>Note 1</small>	
Storage Environment	Equipment must be stored in its original packing in a well-ventilated, dry building or warehouse that provides protection from extremes of temperature, the weather, rodent and insect infestation.	
Shelf Life <small>Note 2</small>	If no DC power is applied to the equipment for a long period there is a risk that the performance of large capacity electrolytic capacitors can decline. When leaving equipment unused for a long time, it is recommended that the system is powered up once every two years and is left switched ON in a standby state for a minimum of 5 hours. Where possible and whilst switched ON, the basic functions of the system should be checked to ensure that the system is operational.	

Note 1: Please refer to section 12.2 for details on packing and returning a unit.

Note 2: The long term storage test procedures for equipment are not defined in this document. Please contact Kelvin Hughes for specific instructions on packing, re-packing, powering and testing of systems.

SharpEye™ SCV & SxV X-Band Radome Radar
Chapter 13: Specifications

13.3 Transceiver specifications

DC POWER REQUIREMENTS

DC input	+24VDC DC range: +19.5VDC to 30VDC measured at the unit under maximum load conditions
DC power cable	Standard systems use 10 metre DC power cables. If additional DC cabling is required, the cable must be of a sufficient gauge to ensure that the minimum voltage required by the SCV/ SxV is maintained under the worst case load conditions. The cable must be designed to ensure that the voltage drop along the cable never causes the DC supply measured at the SCV/ SxV power connector to fall below +19.5VDC under maximum load conditions. For cable runs longer than 10m, Kelvin Hughes recommend a DC supply of at least +28VDC and/ or a cable and DC supply that supports sensing lines.
DC Power	150W typical, 250W peak
Breaker/ fuse rating	10A @ 24VDC breaker

SharpEye™ RADOME RADAR

Transmission frequency	X-band transmission with 9 LAN configurable frequencies between 9.22GHz to 9.38GHz in steps of 0.02GHz	
Frequency Bandwidth	20MHz	
PRF	1 – 4.5KHz depending on mode	
Processing	Pulse compression and coherent Doppler processing	
Peak RF power Measured at the output of the SharpEye™ prior to the antenna	High power	Low Power
	50 to 80W (typical) 47 to 50dBm (in normal operation)	12W (typical) 39.5 to 42.5dBm
ERP (Effective Radiated Power)	Peak radiated power (ERP) = 42dBW Mean radiated power (ERP) = 33dBW	
Pulse duty cycle	13% maximum (hardware limited)	
Range scales	6, 12, 24Nm	
Blanking (mute)	Three mute (blinking) and one True.	

ANTENNA

Size	530mm horizontally polarised planar array
Beamwidth	20 to 22° vertical, ≤ 3.9° azimuth Note: Due to the beamwidth of the antenna, target detection will be significantly reduced if the SCV/ SxV assembly is tilted by more than 10° from horizontal/ flat.
Tilt	No tilt 0° with respect to mounting points (horizontal)
Gain	20 – 22dBi
Rotation speed	12RPM or 24RPM dependent of range scale and software installed. Please contact Kelvin Hughes Ltd for further information.

EXTRANAL INTERFACES

LAN connection	<p>The LAN connection provides control (<i>CAT253 ASTERIX format</i>), and radar video (<i>CAT240 ASTERIX format</i>).</p> <p>The specification for the ASTRIX CAT240 video LAN output and protocol is available on request.</p> <p>Please contact Kelvin Hughes for additional details including system integration information.</p> <p>Where required, network switches must support Gigabit Ethernet (1000 Base-T) and IGMP snooping.</p>
----------------	--

INTERNAL SENSOR

Position, heading, pitch and roll data	<p>Position and direction information can be outputted from the SCV/ SxV via the LAN in a UDP message format. The data provided is for reference use only and cannot be used as a primary source of navigation data.</p> <p>GGA, GSA, GSV, RMC, VTG, ZDA, GLL and HDG outputs are available. Pitch and roll data is also available in a XDR format.</p> <p>Sensor data is not enabled by default. Please contact Kelvin Hughes Ltd for details on system integration and the system configuration.</p>
--	--

13.4 Approvals

All Kelvin Hughes Ltd designed equipment is designed and manufactured to Kelvin Hughes' own standards of practice and is also designed to meet the applicable requirements of the following directives:

Vibration & Shock	Designed to meet IEC 60945
Climatic	Designed to meet IEC 60945
Ingress Protection	Protected to IP67 (dust tight and up to 1.0m water depth)
EMC	Designed to meet ETSI EN302248 V1.1.2 (2005-06) and IEC 60945

Page intentionally blank

14 Contact details

Kelvin Hughes Limited
Voltage
6 Mollison Avenue
Enfield
EN3 7XQ
United Kingdom



Phone: +44 (0)1992 805 200

Fax: +44 (0) 1992 805 310

Service	email	service@kelvinhughes.co.uk
	Phone	+44 (0)1992 805 301

Technical Advice	email	technical.advice@kelvinhughes.co.uk
	Phone	+44 (0)1992 805 302

Spares	email	spares@kelvinhughes.co.uk
	Phone	+44 (0)1992 805 301

Internet	Website	www.kelvinhughes.com
-----------------	---------	--



Kelvin Hughes Ltd

Voltage, 6 Mollison Avenue
Enfield, EN3 7QX, United Kingdom

Tel: +44 (0) 1992 805200

Fax: +44(0) 1992 805310

WWW.kelvinhughes.com

SITUATIONAL AWARENESS, THE WORLD OVER