



## Upright Freezer

**Model 21501**

**5.0 cu. ft. Capacity**

### Caution:

Before using your freezer, carefully read this manual and the use and care information inside the freezer door.

### Read This Manual!

It will tell you how to operate and care for your freezer. It also offers tips on how to get the best and lowest cost performance.

If you prefer installing your own parts, use the parts list to find the part number. Do not use the illustration number.

In the space below record the model and serial number of your freezer. Each is printed on the model number plate located in the upper corner of the refrigerator back. Use these numbers when calling for service.

Model No. \_\_\_\_\_ Serial No. \_\_\_\_\_

Date Purchased \_\_\_\_\_

### Manual Contents:

- Warranty
- Installation
- Operation
- Maintenance
- Troubleshooting
- Parts

### Full One-Year Warranty on Freezer

For one year from date of purchase, when this freezer is operated and maintained according to instructions attached to or furnished with the product, Sears will repair this freezer, free of charge, if defective in material or workmanship.

### Full Five-Year Warranty on Sealed Refrigeration System

For five years from the date of purchase, when this freezer is operated and maintained according to instructions attached to or furnished with the product, Sears will repair the sealed system (consisting of refrigerant, connecting tubing, and compressor motor) free of charge, if defective in material or workmanship.

The above warranty coverage applies only to freezers which are used for storage of food for private household purposes.

WARRANTY SERVICE IS AVAILABLE BY CONTACTING THE NEAREST SEARS SERVICE CENTER/DEPARTMENT IN THE UNITED STATES.

### Installation

#### Inspection

When your new freezer is delivered, check thoroughly for shipping damage and missing parts. If you find either, please notify Sears at once.

#### Location is Important

Your new freezer will work best in a dry, ventilated place, where the temperature falls between 65 and 110 F. Extreme temperatures can shorten the freezer's life. Very high temperatures (such as in an unventilated garage in summer) also will make your freezer run more, increasing its operating cost.

Your freezer must be allowed enough space for proper air circulation. This freezer is designed for **FREESTANDING INSTALLATION ONLY** and should not be recessed or built-in. Allow 3 inches of space on each side and rear and 4 inches on the top of the cabinet. This is particularly important in hotter climates.

Pick a spot where the floor will support the weight of the freezer fully loaded. It is best to keep your freezer away from an oven or other heat source. Pick a safe place, indoors, away from flammables such as gasoline.

---

**Sears, Roebuck and Co., Hoffman Estates, IL 60179 U.S.A.**

---

## Leveling the Freezer

To ensure proper door seal and optimum performance, level freezer using the leveling leg located on its bottom front corner.

- Once your freezer is in the desired location, use a carpenter's level and adjust the leveling leg as necessary to make sure the cabinet is level side-to-side.
- Adjust the leg to achieve a 1/4 inch slope from front-to-back (1/2 bubble on a carpenter's level) to provide easy door closure and proper door seal.
- If the rear corners need to be raised, use shims made of wood or other hard materials. Cardboard and other soft materials will not work.

## Electrical Requirements

- 120 Volts, 60 Hz (60 cycles AC), 15 amps
- DO NOT use an extension cord.
- Select an electric wall outlet that cannot be turned off by a switch or pull chain. Be sure that the electric outlet you select does not need a ceiling drop cord.
- Use a fuse or circuit-breaker protected circuit that will not become overloaded when the freezer is installed.

## Electrical Grounding

Your freezer comes with a three-prong plug and must be inserted into a three-prong, grounded wall outlet.

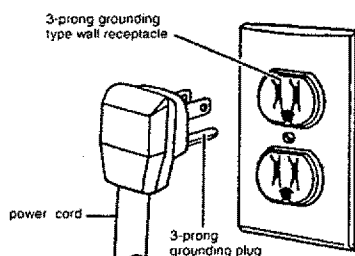

**WARNING:** Unless the grounding method described above is followed, you are not protected against severe or lethal shock in the event of the short circuit of the freezer's wiring or electrical components.

## Operation

### Starting

The freezer temperature can be regulated by adjusting the control. The evaporator forms the storage shelves of the unit which provides even freezing temperatures throughout the freezer. Freezer temperature will vary depending on the quantity of food stored and on the frequency of door openings.

Wait 4 hours before loading the freezer. It takes time to reach storage temperature. During this time the freezer may run constantly.

## Maintenance

### Defrosting



**DANGER:** Electrical Shock Hazard. Disconnect power before defrosting.

You should defrost your freezer when the frost becomes 1/4 inch thick. Further accumulation will reduce operating efficiency. How often you have to defrost depends on the type amount of food you freeze, the temperature and humidity and the number of times you open and close the freezer. The period between defrosting can be extended by scraping frost every so often with a plastic scraper.

### Defrosting Steps

1. Turn the unit OFF.
2. Remove all food and place it in cardboard boxes or wrap it in several thickness of newspaper. This action will keep food safely frozen while you defrost and clean your freezer.
3. The drip tray should be placed at the bottom of the cabinet.
4. Leave the door open and wait for frost to soften. Place pans of hot water on the shelves or use an electric fan blowing into the freezer to speed defrosting. Do not use electric defrost devices as they can damage the plastic parts of your freezer.
5. Remove soften frost with a plastic or wooden scraper, or a cloth or sponge. **CAUTION: NEVER USE SHARP OBJECTS TO REMOVE FROST.** They could puncture freezing coils and severely damage the refrigeration system.
6. Defrost water will accumulate in the drip tray. Discard water from the drip tray.
7. Clean the inside of the freezer. Cleaning instructions are described below and on the permanent use and care label on the inside of the freezer door.
8. Turn the unit back on and place the frozen foods back inside the freezer.

### Cleaning

- Use only mild soapy water to clean door gaskets.
- Turn off the freezer and remove foods. Wash interior liner with a solution of warm water and two table-spoons baking soda per one quart of water. Rinse and wipe clean. DO NOT use soaps, detergents, scouring powder, spray cleaner or the like for the liner. They may create unwanted odors in the freezer.
- Use a vacuum cleaner to clean the condenser (tube and wire attachment) on the back of the freezer.
- Wash the exterior with detergent or soap and water. Rinse well and wipe dry.
- DO NOT use scouring powders or pads. Never use acids, chemical thinner, gasoline, benzene, or the like for cleaning any part of the freezer. Boiling water and benzene may deform and damage plastic parts.

## Loading the Freezer

To prepare food for freezing, use only containers and wrapping materials made especially for freezers. For fast efficient freezing DO NOT freeze more than three pounds of UNFROZEN food per cubic foot capacity of your freezer. For example, if the capacity of your freezer is 10 cubic feet, do not freeze more than 30 pounds of unfrozen food at one time. DO NOT place hot food in the freezer.

## Power Failure

**If electrical power fails and will be off for less than 24 hours:** Keep freezer door closed and food will stay frozen.

**If power will be off for more than 24 hours, do one of the following:**

- Take food to frozen food locker
- Place dry ice in the freezer. First cover food packages with newspaper or cardboard. Then spread dry ice over this covering. Be careful that dry ice is not directly touching the food packages as it could "burn" the food.
- If locker storage space is not available, or you cannot get dry ice, use perishable food immediately.

## When Is It Safe To Refreeze Food?

If food still contains ice-crystals, it may be safe to refreeze it although its quality may suffer slightly. Refrozen food " should be used as soon as possible. If food is completely defrosted but still cold to touch (lower than 40\* F), use it immediately or cook food and then freeze for future use. If there is any question about whether food is good or not, dispose of it.

## Vacation/Moving

If you shut the freezer off for a period of time (more than 24 hours) or are moving the freezer:

Remove all food and unplug freezer.

Clean thoroughly per Cleaning 1 instructions above. Prop door open so air can circulate to prevent odor and mold growth. CAUTION: To help prevent accidents, do not allow small children to have access to the freezer when its door is open.

- Before moving freezer take out all removable shelves, baskets or bins and tape or lock door shut to prevent accidental damage.
- Ship freezer in upright position. Do not lay freezer down.
- Make sure new location can support the weight of the loaded freezer.
- Level freezer at new location to insure proper door seal.

## Food Loss Coverage Limitation

If promptly reported to your nearest Sears Store or Service Center, Sears will reimburse you up to a total of \$100.00 for the value of food, as verified by Sears, lost while stored in the freezer when used for private household purposes, as a result of:

- Defects that occur during the first year following date of purchase
- Failure of the sealed system (including refrigerant, connecting tubing and compressor motor) due to defects that occur during the second through fifth year after purchase.

If freezer is used for other than private household purposes, Sears will not be responsible for any food loss. Food losses resulting from other than the above stated defects, such as: natural spoilage, power interruption, inadequate power, manual disconnect of power supply, fire damage, water damage, theft, etc., are beyond our control and are not covered by Sears.

Some states do not allow the exclusion or limitation of incidental or consequential damages, so the above limitation or exclusion may not apply to you.

This warranty gives you specific rights and you may also have other rights which vary from state to state.

Sears, Roebuck and Co., D/817WA, Hoffman Estates, IL 60179

## Troubleshooting

### My Freezer Is Too Warm...

- Make sure the door is fully closed.
- Level the freezer to ensure proper door seal.
- Clean the condenser coils on the back to improve function.  
Moisture Collects on the Outside...
- Reduce the time the door is open. Frequent door openings in humid conditions will cause this condition.
- Make sure the door seal is tight and level freezer to ensure proper door seal.

### My Freezer is Noisy...

- Make sure the cabinet is resting squarely on the floor on all four corners without touching a wall or other surfaces.
- Make sure the condenser coils on the back are free of lint and dust.
- Some noises, such as the refrigerant gurgling as it passes through tubes and the compressor hum clicking on and off, are normal.

### There Is an Odor In My Freezer...

- Check for spoiled food.
- Clean interior per Cleaning instructions.



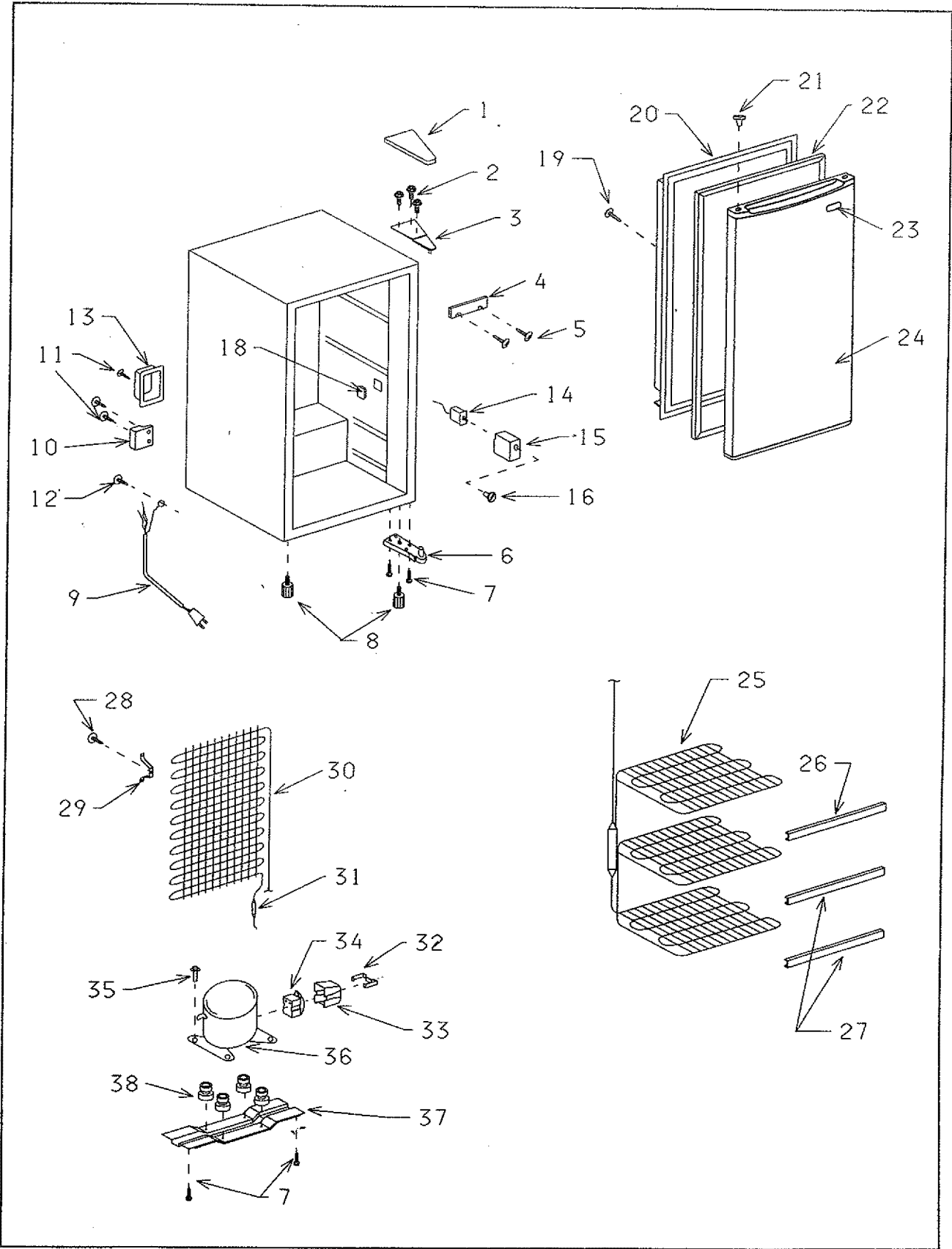

# Get fixed, at your home or ours!

## Your Home

For repair-in your home-of all major brand appliances, lawn and garden equipment, or heating and cooling system, **no matter who made it, no matter who sold it!**

For the replacement parts, accessories and owner's manuals that you need to do-it-yourself.

For Sears professional installation of home appliances and items like garage door openers and water heaters.

**1-800-4-MY-HOME®** (1-800-469-4663)

Call anytime, day or night (U.S.A. and Canada)

[www.sears.com](http://www.sears.com) [www.sears.ca](http://www.sears.ca)

## Our Home

For repair of carry-in items like vacuums, lawn equipment, and electronics, call or go on-line for the location of your nearest **Sears Parts & Repair Center.**

**1-800-488-1222**

Call anytime, day or night (U.S.A. only)

[www.sears.com](http://www.sears.com)

To purchase a protection agreement on a product serviced by Sears:

**1-800-827-6655** (U.S.A.)

**1-800-361-6665** (Canada)

Para pedir servicio de reparación a domicilio, y para ordenar piezas:

**1-888-SU-HOGAR<sup>SM</sup>**

(1-888-784-6427)

Au Canada pour service en français:

**1-888-LE-FOYER<sup>MC</sup>**

[www.sears.ca](http://www.sears.ca)

# SEARS

® Registered Trademark/<sup>TM</sup> Trademark/<sup>SM</sup> Service Mark of Sears, Roebuck and Co.

® Marca Registrada/<sup>TM</sup> Marca de Fábrica/<sup>SM</sup> Marca de Servicio de Sears, Roebuck and Co.

<sup>MC</sup> Marque commerce/<sup>MC</sup> Marque déposée de Sears, Roebuck and Co.