



Kenmore Elite 40-Inch Dual-Fuel Sealed Gas Range

**22-75603** – Stainless

- The best of both cooking worlds—gas on top and electric in the oven!
- True convection cooking with third element in main oven
- 3.7 cu. ft. automatic self-cleaning main oven
- 1.7 cu. ft. standard-clean auxiliary oven
- Three heavy-duty oven racks in main oven plus one standard auxiliary oven rack
- Five sealed gas burners on gas-thru-glass cooktop
- One 14,200 BTU and one 12,000 BTU power burners
- Two 9,500 BTU all-purpose burners
- One 5,000 BTU simmer burner
- Dishwasher-safe, porcelain-coated cast-iron continuous grates with wok stand
- Electronic oven controls with lockout
- Sabbath mode
- Extra large storage drawer

<b>Model</b>	<b>22-75603</b>
Overall	Stainless
Console	Stainless
Knobs	Graphite
Door	Stainless
Handles	Stainless
Sides	Graphite
Surface	Black

Selection	
Stainless	22-75603
Oven Features	
Oven Capacity (cu. ft.)	3.7 (Aux. 1.7)
Cleaning System	Self-Clean Main
Variable Time Self-Cleaning	•
Electronic Oven Controls	•
Control Lockout	Oven
Auto Convection Conversion	•
Slow Cook	•
Add-1-Minute Timer	•
Cook & Hold Warm Oven	•
Delay Start	Cook & Clean
Automatic Oven Shutoff	•
Sabbath Mode†	•
True Convection with Third Element	•
Variable Broiling System	Advanced 400° – 550°
Total Adjustable Oven Racks	3 Heavy-Duty (Aux. 1)
Searing Grill	•
Broiler Pan and Grill	•
Oven Lights	2 (Aux. 1)
Removable Stainless Door	•
Window	X-Large
Oven Interior WxHxD (In.) Main	22 5/8 x 15 3/4 x 17 3/4
Oven Interior WxHxD (In.) Aux.	9 9/16 x 16 x 19 1/2
Cooktop Features	
Burner Type	Sealed
	1 @ 14,200
	1 @ 12,000
Power Burner (BTU)	
All-Purpose Burner (BTU)	2 @ 9,500
Simmer Burner (BTU)	1 @ 5,000
Wok Stand	Included
Grate Styling	Continuous
Porcelain Coated Cast-Iron Grates	•
Dishwasher-Safe Grates	•
Cooktop Surface	Gas-Thru-Glass
Valves (Degree of Turn)	270
General Features	
Drawer	X-Large Storage
Electronic Ignition	•
Power Rating (kW) @ 240V / 208V	4.5 / 3.4
Bake / Broil @ 240V (Watts)	3,000 / 2,750 (Main) 1,500 / 1,500 (Aux.)
Breaker / Copper Wire Size (240V)	40 / 8
Shipping Weight (Approx. Lbs.)	283
Warranty	
1-Year Limited Warranty – Entire Appliance	Parts & Labor
2-5 Year Limited Warranty – Glass Cooktop, Cooktop Elements	Parts

If used for other than private family purposes, warranty applies for only 90 days.

Aux. = Auxiliary

†Sabbath Mode overrides auto oven shutoff

\*LP orifices included; conversion must be done by qualified LP installer

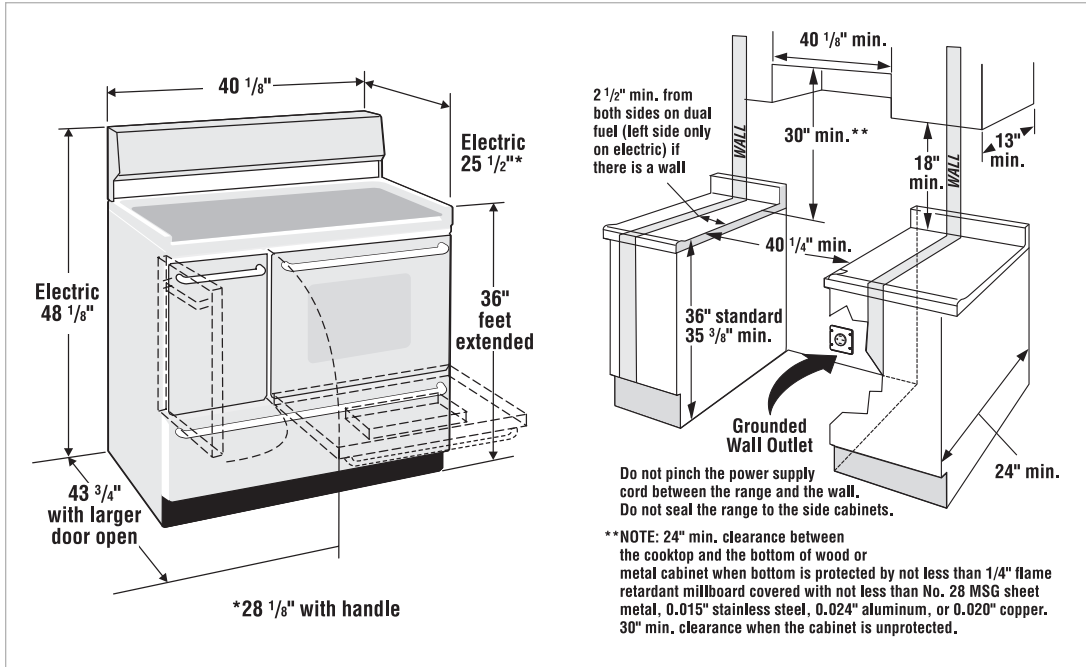

22-49614, 22-49616

Range Cords for Electric Ranges

Order	Wire	Length
22-49614	3	4 ft.
22-49616	3	6 ft.
22-49624*	4	4 ft.
22-49626*	4	6 ft.

\*Complies with 1/1/96 NEC code revision for new construction and remodeling

22-49624, 22-49626

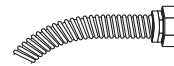
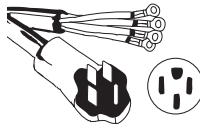

**Gas Connector—Stainless Steel**  
 22-49694 | 60" Length, 1/2" I.D.



All ranges are equipped with an Anti-Tip device. The installation of this device is an important, required step in the installation of the range.