

Use & Care Guide
Manual de Uso y Cuidado
English / Español



System tested and certified by NSF International against NSF/ANSI Standard 42 for the reduction of chlorine taste and odor, and Standard 44 for hardness reduction, efficiency and the reduction of barium and radium 226/228, and certified to NSF/ANSI Standard 372.

Este sistema ha sido probado y certificado por NSF International según la norma NSF/ANSI 42 para la reducción del sabor y el olor a cloro, y la norma 44 para la reducción de la dureza, eficiencia y la reducción del bario y del radio 226/228, y certificado según la norma NSF/ANSI 372.

Model / Modelo No. 625.385200

Kenmore Elite®

Hybrid Water Softener

A water softener and a whole home filter in one

Ablandador Híbrido de Agua

Un ablandador de agua con filtro integrado para toda la casa

Sears Brands Management Corporation
3333 Beverly Road
Hoffman Estates, IL 60179 U.S.A.
www.kenmorewater.com
www.kenmore.com
www.sears.com



P/N 7332880 (Rev. E 11/7/12)

Warranty

WARRANTY ON KENMORE ELITE® HYBRID WATER SOFTENER

ONE YEAR LIMITED WARRANTY ON HYBRID WATER SOFTENER

When installed, operated and maintained according to all instructions supplied with the product, if this Kenmore appliance fails due to a defect in material and workmanship within one year from the date of purchase, call 1-800-4-MY-HOME® to arrange for free repair.

THREE YEAR LIMITED WARRANTY ON ELECTRONIC PARTS

When installed, operated and maintained according to all instructions supplied with the product, if any of the following electronic parts fail due to a defect in material or workmanship, call 1-800-4-MY-HOME® to arrange for free part replacement: Brine Tank Light, Electronic Board, Sensor Housing, Wiring Harness, Transformer, Micro Switch, Drive Motor, Power Cable. After the first year you must pay an initial trip charge.

TEN YEAR LIMITED WARRANTY AGAINST LEAKS

When installed, operated and maintained according to all instructions supplied with the product, if the water softener tank or salt storage drum develops a leak within ten years from the date of purchase, call 1-800-4-MY-HOME® to arrange for free tank or drum replacement. After the first year you must pay an initial trip charge.

All warranty coverage does not include water softener resin or carbon, which are expendable items.

If this appliance is used for other than private family purposes, this warranty applies for only 90 days from the date of purchase.

This warranty covers only defects in material and workmanship. Sears will NOT pay for:

1. A service technician to instruct the user in correct product installation, operation or maintenance.
2. A service technician to clean or maintain this product.
3. Damage to or failure of this product if it is not installed, operated or maintained according to the all instructions supplied with the product.
4. Damage to or failure of this product resulting from accident, abuse, misuse or use for other than its intended purpose.
5. Damage to or failure of this product caused by the use of detergents, cleaners, chemicals or utensils other than those recommended in all instructions supplied with the product.
6. Damage to or failure of parts or systems resulting from unauthorized modifications made to this product.

Disclaimer of implied warranties; limitation of remedies

Customer's sole and exclusive remedy under this limited warranty shall be product repair as provided herein. Implied warranties, including warranties of merchantability or fitness for a particular purpose, are limited to one year or the shortest period allowed by law. Sears shall not be liable for incidental or consequential damages. Some states and provinces do not allow the exclusion or limitation of incidental or consequential damages, or limitation on the duration of implied warranties of merchantability or fitness, so these exclusions or limitations may not apply to you.

This warranty applies only while this appliance is used in the United States or Canada.

This warranty gives you specific legal rights, and you may also have other rights which vary from state to state.

Sears Brands Management Corporation, Hoffman Estates, IL 60179 U.S.A.

Table of Contents

Warranty	2
Safety Guides	3
Specifications & Performance Claims	4-5
Dimensions	5
Packing List	6
Plan Your Installation	6-8
Installation	8-12
Programming the Softener	13-14
Flushing the System	15
Adding Salt to the Storage Tank	15
What Your Hybrid Water Softener Will Do	16
Controller Features	16-20
Care of Your Water Softener	21
Service Information	21-25
Exploded View & Parts List	26-29

Safety Guides

- ▲ Read all steps and guides carefully before installing and using your new water softener. Follow all steps exactly to correctly install. Failure to follow them could cause personal injury or property damage. Reading this manual will also help you to get all the benefits from your water softener.
- ▲ Your Kenmore Elite® Hybrid Water Softener will reduce hardness minerals from water. This is measured in grains per gallon (gpg). It will also remove some clear water iron*. This is measured in parts per million (ppm). See the specifications page for the maximum limit of hardness removal. It will also reduce taste and odor in water, and will reduce barium and radium 226/228 in water (see performance data sheet for details).
- ▲ A water softener will not improve other water problems such as acidity or iron other than clear water iron.
- ▲ Do not attempt to use this product to make safe drinking water from non-potable water sources. Do not use the system on microbiologically unsafe water, or water of unknown quality without adequate disinfection before or after the system.
- ▲ Check with your local public works department for plumbing and sanitation codes. You must follow their guides as you install the system. Follow your local codes if they differ with guides in this manual. In Massachusetts, plumbing code 248-CMR 3.00 and 10.00 shall be adhered to. Consult with a licensed plumber.
- * The capacity to reduce clear water iron is substantiated by Water Quality Association test data.
- ▲ Use only lead-free solder and flux for all sweat-solder connections, as required by federal codes, when installing soldered copper plumbing.
- ▲ Use care when handling the water softener. Do not turn upside down or drop.
- ▲ Avoid installing in direct sunlight. Excessive heat may cause distortion or other damage to non-metallic parts.
- ▲ This water softener works on water pressures of 20 psi (minimum) to 125 psi (maximum). If your house water pressure is over the maximum, install a pressure reducing valve in the water supply pipe to the softener.
- ▲ Temperature of the water supply to the softener must be between 40°F and 120°F. Do not install on hot water.
- ▲ If installing the water softener outdoors, do not locate where it will be exposed to wet weather, direct sunlight or extreme hot or cold temperatures.
- ▲ This softener works on 24 volt, 60 Hz electrical power only, supplied by a direct plug-in transformer (included). Be sure to use the included transformer and plug it into a nominal 120V, 60 cycle household outlet that is properly protected by an overcurrent device such as a circuit breaker or fuse. If transformer is replaced, use only the authorized service, Class II, 24V 10VA transformer.
- ▲ This water softener has a non-metallic valve system. Installing it on metal plumbing will break electrical continuity, which may interrupt grounding for the home. You must restore electrical continuity in your metal plumbing system (See Page 12).



European Directive 2002/96/EC requires all electrical and electronic equipment to be disposed of according to Waste Electrical and Electronic Equipment (WEEE) requirements. This directive or similar laws are in place nationally and can vary from region to region. Please refer to your state and local laws for proper disposal of this equipment.

Specifications & Performance Claims

This model is efficiency rated. The efficiency rating is valid only at the minimum salt dose. The softener has a demand initiated regeneration (D.I.R) feature that complies with specific performance specifications intended to minimize the amount of regenerant brine and water used in its operation.

This softener has a rated softener efficiency of not less than 3,350 grains of total hardness exchange per pound of salt (based on sodium chloride) and shall not deliver more salt than its listed rating or be operated at a sustained maximum service flow rate greater than its listed rating. This softener has been proven to deliver soft water for at least ten continuous minutes at the rated service flow rate. The rated salt efficiency is measured by laboratory tests described in NSF/ANSI Standard 44. These tests represent the maximum possible efficiency that the system can achieve. Operational efficiency is the actual efficiency after the system has been installed. It is typically less than the rated efficiency, due to individual application factors including water hardness, water usage, and other contaminants that reduce a softener's capacity.

While testing was performed under standard laboratory conditions, actual performance of the system may vary based on local water conditions. This system has been tested according to NSF/ANSI Standard 42 for the reduction of chlorine taste and odor. The concentration of the indicated substance in water entering the system was reduced to a concentration less than or equal to the permissible limit for water leaving the system, as specified in NSF/ANSI Standard 42.

SPECIFICATIONS											
	Model No. 625.385200										
Model Code	520										
Rated Softening Capacity (Grains @ Salt Dose)	11,000 @ 2.6 lbs. 24,700 @ 7.8 lbs. 31,100 @ 13.4 lbs.										
Rated Efficiency (Grains/Pound of Salt @ Minimum Salt Dose)	4,230 @ 2.6 lbs.										
Water Used During Regeneration @ Minimum Salt Dose	5.0 gallons / 1,000 grains										
Total Water Used Per Regeneration @ Maximum Salt Dose	54.7 gallons										
Rated Service Flow Rate	8.0 gpm										
Amount of High Capacity Ion Exchange Resin	0.98 cu. ft.										
Pressure Drop at Rated Service Flow	6.5 psig										
Water Supply Max. Hardness	100 gpg										
Water Supply Max. Clear Water Iron	3 ppm*										
Water Pressure Limits (minimum / maximum)	20 - 125 psi										
Water Temperature Limits (minimum / maximum)	40 - 120 °F										
Minimum Water Supply Flow Rate	3 gpm										
Intermittent Flow @ 15 psi	13.7 gpm**										
Maximum Drain Flow Rate	2.0 gpm										
Rated Capacity at Chlorine Concentration*** of:	<table style="margin-left: auto; margin-right: auto; border: none;"> <tr> <td style="padding: 0 10px;">0.50 ppm</td> <td style="padding: 0 10px;">2,280,000 gal.‡</td> </tr> <tr> <td style="padding: 0 10px;">0.75 ppm</td> <td style="padding: 0 10px;">1,520,000 gal.‡</td> </tr> <tr> <td style="padding: 0 10px;">1.0 ppm</td> <td style="padding: 0 10px;">1,140,000 gal.‡</td> </tr> <tr> <td style="padding: 0 10px;">1.5 ppm</td> <td style="padding: 0 10px;">760,000 gal.‡</td> </tr> <tr> <td style="padding: 0 10px;">2.0 ppm</td> <td style="padding: 0 10px;">570,000 gal.</td> </tr> </table>	0.50 ppm	2,280,000 gal.‡	0.75 ppm	1,520,000 gal.‡	1.0 ppm	1,140,000 gal.‡	1.5 ppm	760,000 gal.‡	2.0 ppm	570,000 gal.
0.50 ppm	2,280,000 gal.‡										
0.75 ppm	1,520,000 gal.‡										
1.0 ppm	1,140,000 gal.‡										
1.5 ppm	760,000 gal.‡										
2.0 ppm	570,000 gal.										

* Capacity to reduce clear water iron is substantiated by WQA test data. State of Wisconsin requires additional treatment if water supply contains clear water iron exceeding 5 ppm.

** Intermittent flow rate does not represent the maximum service flow rate used for determining the softener's rated capacity and efficiency. Continuous operation at flow rates greater than the service flow rate may affect capacity and efficiency performance.

*** Typical residential chlorine concentration is 0.5 to 1.0 ppm.

‡ From independent laboratory test data.

This system conforms to NSF/ANSI Standards 42 & 44 for the specific performance claims as verified and substantiated by test data.

Variable Salt Dose: The salt dose is selected by the electronic controls at regeneration time based on the amount needed.

Questions? Call the Kenmore Water Line 1-800-426-9345 or visit www.kenmorewater.com

Specifications & Performance Claims

PERFORMANCE CLAIMS		
Contaminant	Influent Challenge Level	Maximum Allowable Product Water Level
Barium	10 ±10% mg/L	2.0 mg/L
Radium 226/228	25 pCi/L	5 pCi/L
Substance	Influent Challenge Level	Reduction Requirement
Chlorine	2.0 ±10% mg/L	50%

Dimensions

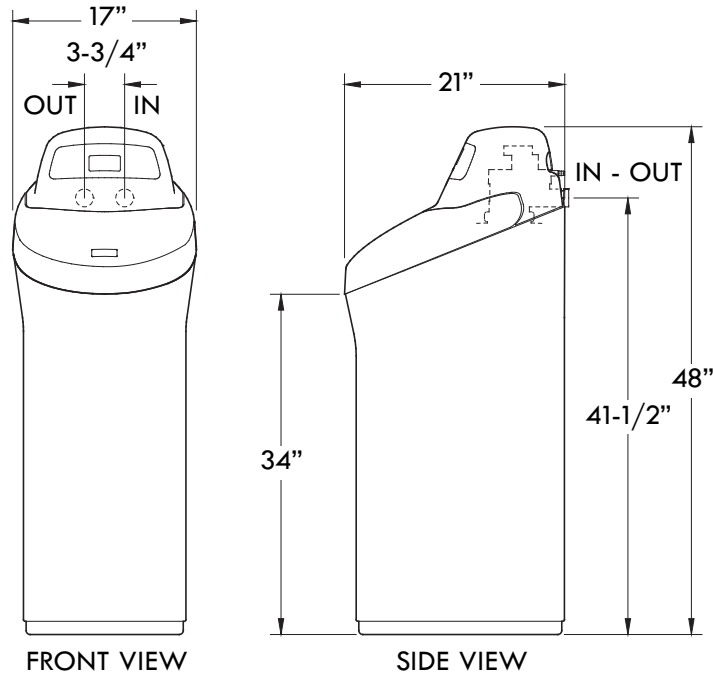

Figure 1

Packing List

The parts required to assemble and install the water softener are included with the unit. Thoroughly check the water softener for possible shipping damage and parts loss. Also inspect and note any damage to the shipping carton.

Remove and discard (or recycle) all packing materials. To avoid loss of small parts, we suggest you keep the small parts in the parts bag until you are ready to use them.

Small Parts

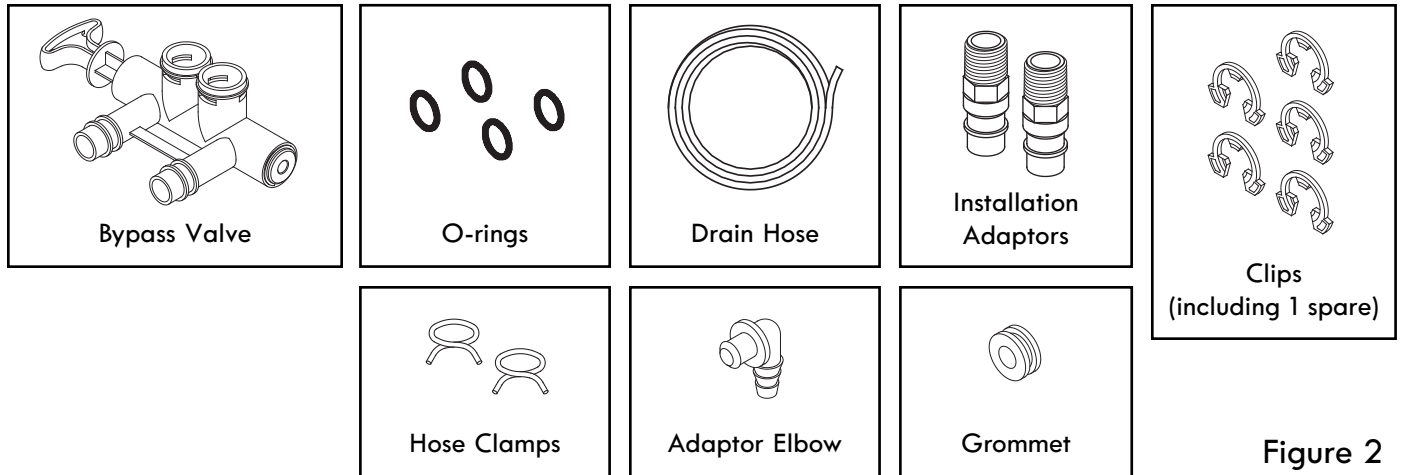
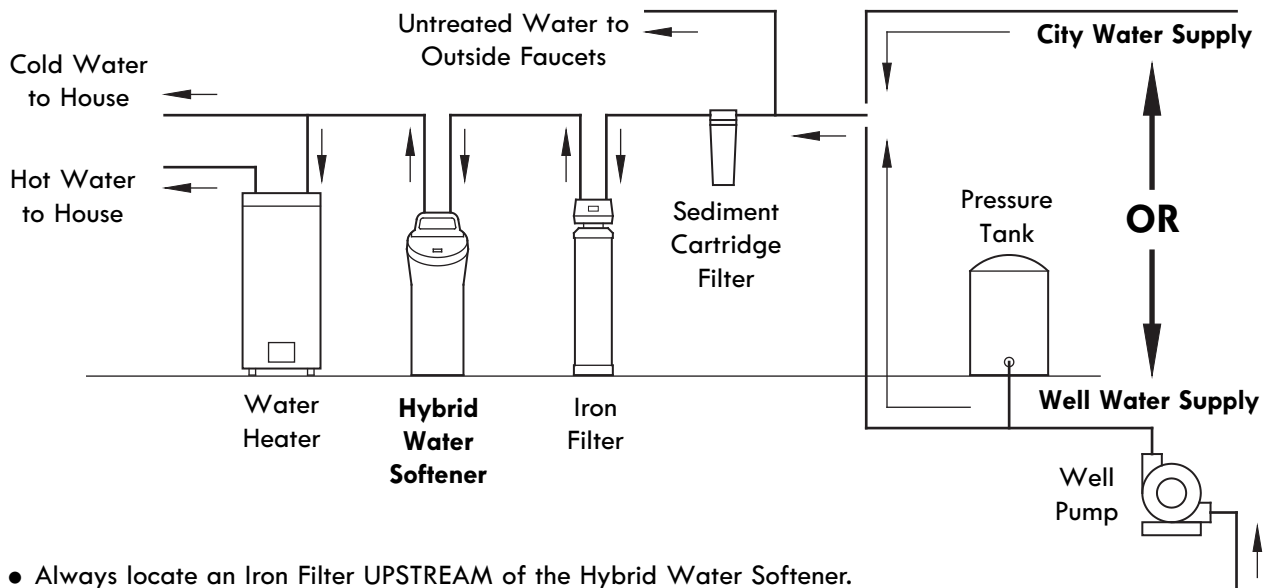

Figure 2

Plan Your Installation

THE PROPER ORDER TO INSTALL WATER TREATMENT EQUIPMENT

(Shows sequence of equipment only - not all items are needed in all applications)



- Always locate an Iron Filter UPSTREAM of the Hybrid Water Softener.

Figure 3

Questions? Call the Kenmore Water Line 1-800-426-9345 or visit www.kenmorewater.com

Plan Your Installation

TYPICAL INSTALLATION

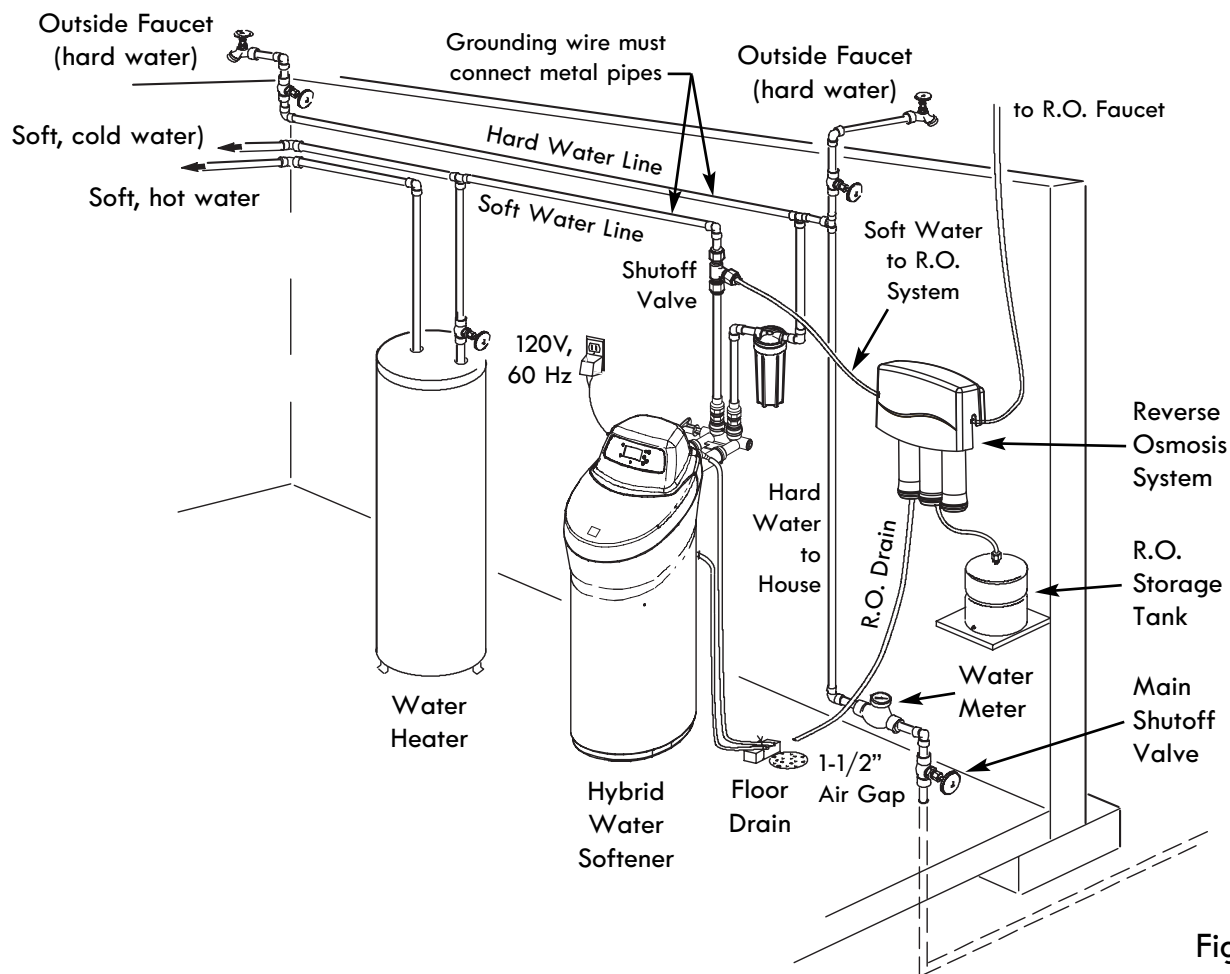

Figure 4

WHERE TO INSTALL THE HYBRID WATER SOFTENER

Review the following points before you choose a place to put your softener:

1. Place as close as possible to, but always downstream from, the pressure tank (well water) or water meter (city water).
2. Place as close as possible to a water drain such as a floor drain, laundry tub, sump or standpipe (See Fig. 4).
3. Connect to the house main water pipe **UPSTREAM OF THE WATER HEATER** (See Fig. 3). The temperature of water going through the softener must not be more than 120°F (49°C). Hot water will damage inner softener parts. To reduce the risk of hot water backup, piping between the softener and water heater should be as long as possible.
4. Keep outside faucets on hard water to save soft water and salt. See Fig. 4.
5. Do not install in a place where the softener could freeze. Damage caused by freezing voids the warranty by Sears Brands Management Corporation.
6. Put the softener in a place where water damage is least likely to occur if it develops a leak. Sears or the manufacturer will not repair or pay for water damage.
7. A grounded, 120V, 60 Hz. electrical outlet is needed near the softener to plug in the transformer (See Fig. 4). Be sure the outlet and transformer are in an inside location, protected from wet weather. Use a continuously "live" outlet, which cannot be accidentally switched off.
8. When installing in an outside location, you must take the steps necessary to assure the softener, installation plumbing, and wiring, are protected from the elements, direct sunlight, contamination, vandalism, etc.

Plan Your Installation

CHECK YOUR WATER PRESSURE BEFORE INSTALLING

For your water softener to work properly, incoming water pressure in your house pipes must be no lower than 20 pounds per square inch (psi). The highest allowable pressure is 125 psi. If pressure is above 125

psi, buy and install a pressure reducing valve in the pipe supplying water to the softener's inlet.

NOTE: If water pressure during the day is 100 psi or more, pressure during the night may go above 125 psi.

Installation

INSTALL SINGLE BYPASS VALVE AND/OR THREADED INSTALLATION ADAPTORS

Complete the following steps to assemble the adaptors and/or the included single bypass valve.

1. Close the shutoff valve on the house main water pipe, near the water meter or pressure tank, to turn off the water.
2. Shut off the gas or electric supply to the water heater.
3. Open the highest and lowest water faucets in your house. This will let water drain from the pipes. Close faucets after water has drained.
4. Remove the top cover. Pull outward on the two tabs to release top cover (see Fig. 5). The salt lid remains attached to the top cover when removed. Set both covers aside so they will not get scratched or broken.

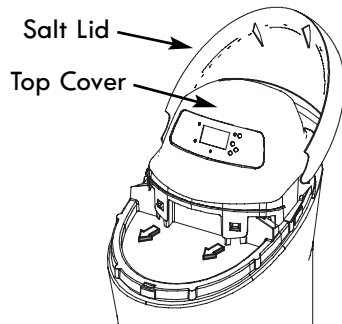

Figure 5

5. Visually check and remove any foreign materials from the valve inlet and outlet ports (see Fig. 6). Carefully remove the two large plastic clips (you will use them). Check to be sure the turbine and support are firmly in place (see Fig. 7).

NOTE: If you will not install the included bypass valve because you will have a 3-valve bypass in your plumbing, skip step 6, but perform step 7.

SINGLE BYPASS VALVE:

6. Lightly coat the o-rings with silicone grease and slide them onto the bypass valve. Push the bypass valve into the softener valve's inlet and outlet ports as far as it will go. Snap the two large holding clips into place, from the top down as shown (see Fig. 8).

CAUTION: Be sure the clips snap firmly into place so the bypass valve will not pull out.

INLET AND OUTLET THREADED ADAPTORS:

7. Lightly coat the o-rings with silicone grease and slide them onto the installation adaptors. Push the adaptors into the valve inlet and outlet ports, or bypass valve ports, as far as they will go. Both adaptors are the same and fit either port. Snap the two large holding clips into place, as shown (see Fig. 8).

CAUTION: Be sure the clips snap firmly into place so the adaptors will not pull out.

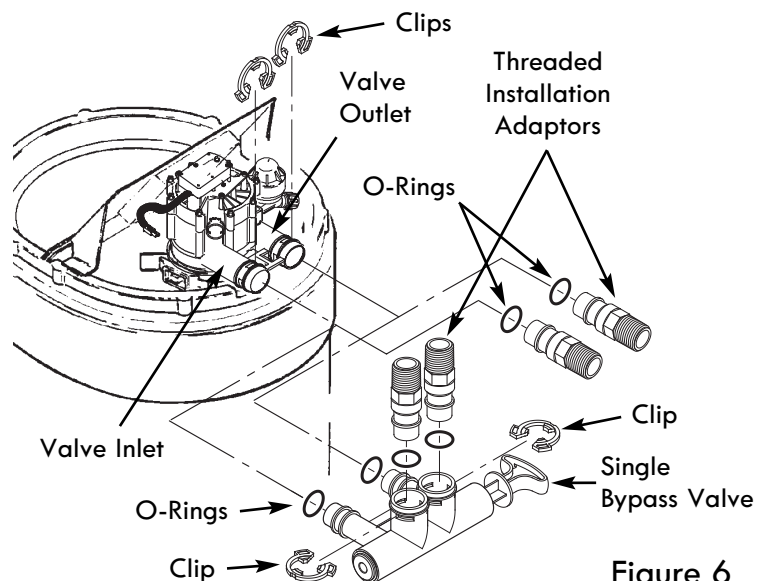

Figure 6

Questions? Call the Kenmore Water Line 1-800-426-9345 or visit www.kenmorewater.com

Installation

INSTALL SINGLE BYPASS VALVE (cont.)

Before installing the bypass valve and/or installation adaptors, make sure that the turbine and support are firmly in place inside the softener valve's outlet port.

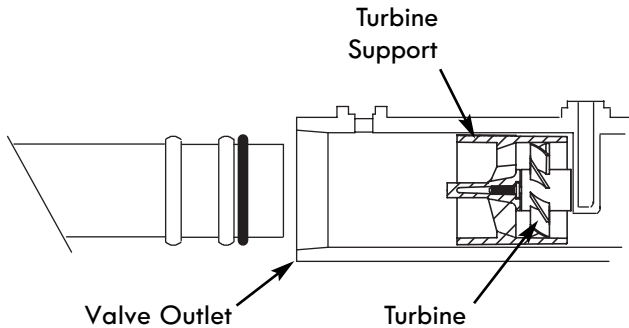

Figure 7

INSTALL HOLDING CLIPS

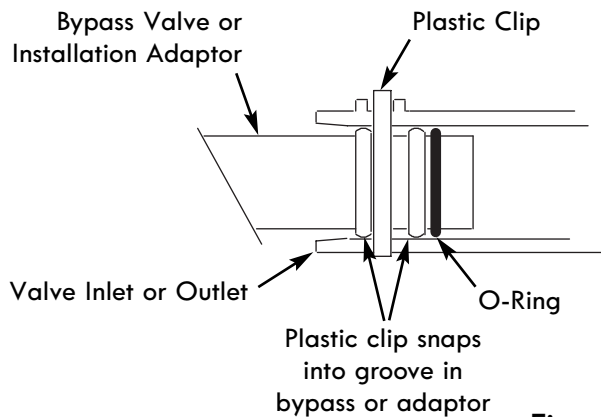

Figure 8

ALTERNATE BYPASS VALVE INSTALLATION

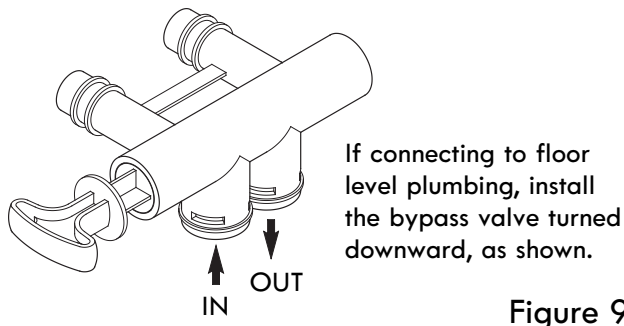

Figure 9

ASSEMBLE INLET AND OUTLET PLUMBING

Measure, cut (thread if needed) and put together all pipe and fittings up to the main water pipe. Make sure that the incoming water supply pipe goes to the valve inlet side.

CAUTION: Never solder fittings while connected to nonmetallic parts. Wait until soldered pipe has cooled before connection. See Fig. 10.

CAUTION: Be careful when putting pipe fittings together. Do not cross thread, and do not over-tighten.

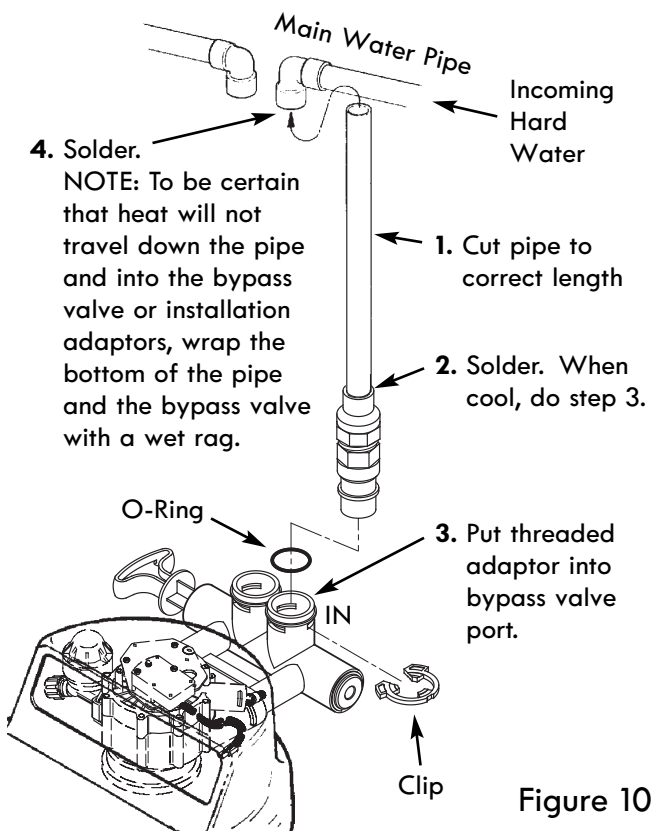

Figure 10

Installation

CONNECT THE VALVE DRAIN HOSE

Take a length of 3/8" inside diameter drain tubing (supplied) and attach one end to the drain fitting (see Fig. 11). Use a tube clamp from the parts bag to hold it in place. Put the other end of the tubing over a floor drain, into a laundry tub, standpipe, or other suitable drain. Check your local codes.

Leave an air gap of about 1-1/2" between the end of the hose and the drain. This gap is needed so you don't get a backflow of sewer water into the softener. Do not put the end of the hose into the drain or connect without the air gap.

Locate and support the hose so it does not kink or have sharp bends. Secure the hose end so water pressure does not cause the hose to "whip". Tie or wire it in place. Do not pinch the hose shut. The softener will not work if this drain hose is pinched, plugged, closed or restricted in any way. Direct drain flow down into drain from drain line as flow could possibly overshoot the drain cover.

Keep the hose lower than the drain fitting. In some homes, to get to a drain you must raise the hose and run it overhead. Do not raise the hose more than 8 feet above the floor.

COPPER DRAIN TUBE: Local plumbing codes may require the use a copper valve drain tube. A copper tube is also best to use if running a drain line overhead.

To adapt a copper drain tube to the softener, purchase a compression fitting (1/4" female pipe threads x 1/2" O.D. tube) and tubing from your local hardware store.

CONNECT SALT TANK OVERFLOW HOSE

1. Locate the rubber grommet, adaptor elbow and tube clamp (see Fig. 11) that are in the parts bag.
2. Push the grommet into the hole in the salt tank wall so that half is inside and half is outside.
3. Push the larger end of the adaptor into the grommet.
4. Push one end of a length of 3/8" I.D. tubing (supplied) onto the tube adaptor, using a tube clamp from the parts bag to hold it in place.
5. Put the other end of the tubing over the floor drain.

IMPORTANT: Overflow water must run down by gravity through the tubing. Do not raise the tubing higher than the adaptor (see Fig. 11).

IMPORTANT: Do not connect this hose to the valve drain hose you just installed (see above). Both drains must have a separate hose.

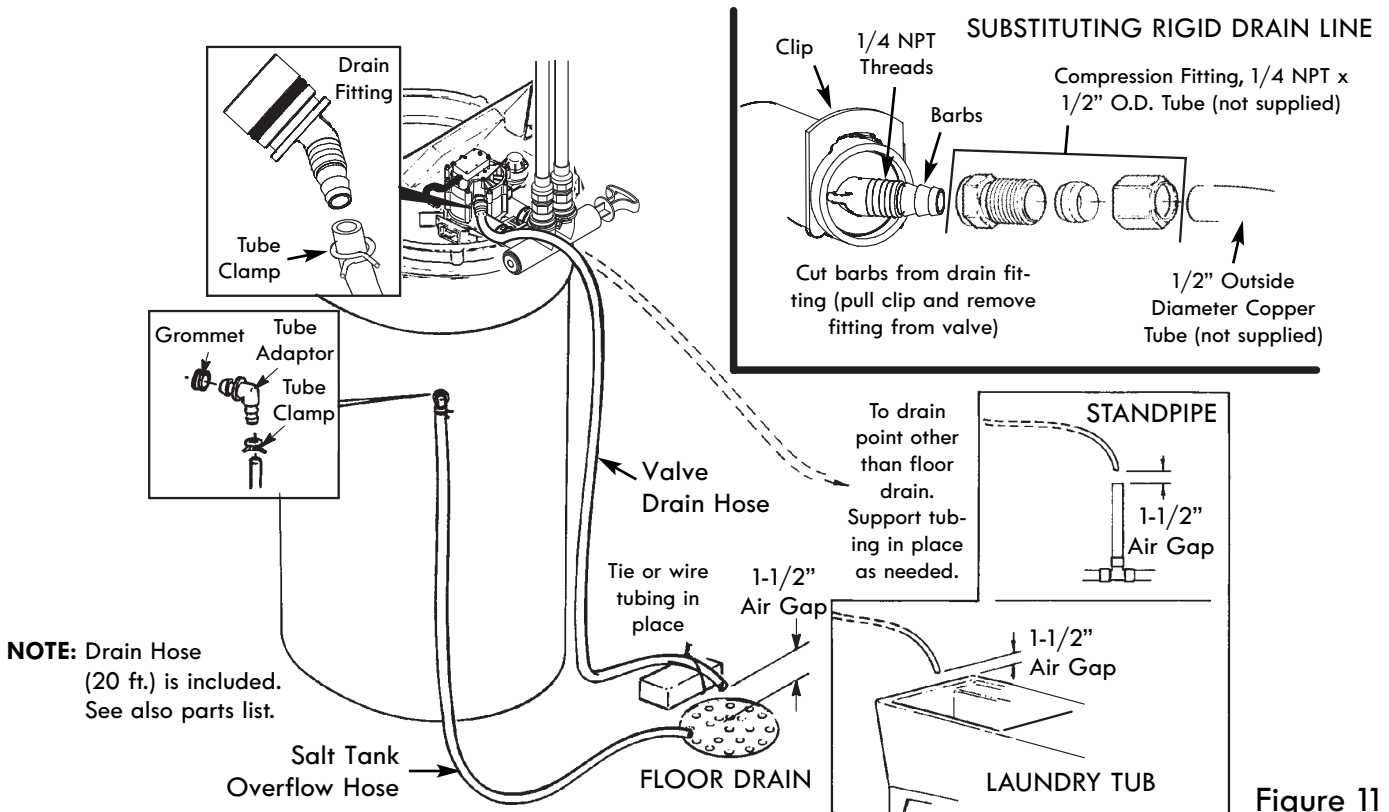

Figure 11

Questions? Call the Kenmore Water Line 1-800-426-9345 or visit www.kenmorewater.com

Installation

METAL PIPE GROUNDING

(parts not included)

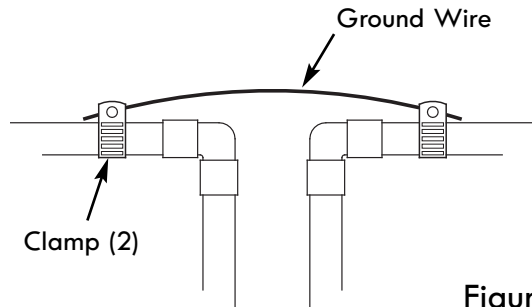

Figure 12

METAL WATER PIPE GROUNDING

IMPORTANT: This water softener has a non-metallic valve system. Installing it on metal plumbing will break electrical continuity, which may interrupt grounding for the home. You must restore electrical continuity in your metal plumbing system.

If you installed a 3-valve bypass system (Fig. 14), electrical continuity will be maintained. If you installed the non-metallic bypass valve (Fig. 13), restore the ground as follows:

Install a #4 copper wire (parts not included) across the removed section of metal water pipe, securely clamping it at both ends (See Fig. 12). Be sure the pipes are clean under the clamps, to assure good contact.

NOTE: If you are installing a sediment filter or other item(s) into the plumbing system, along with the water softener, be sure to restore electrical continuity across all removed metal pipe sections.

INSTALL COVERS

After installing your water softener, put the covers on. Angle the covers so the top cover clips onto the back first, then bring down in front and clip on the tabs inside the rim and lower the salt lid closed (See Fig. 5).

CONNECT TO ELECTRICAL POWER

The softener works on 24 volt, 60 Hz electrical power. The included transformer changes standard 120 volt AC house power to 24 volts. You must plug the water softener's transformer into a grounded, 120 volt outlet only. Be sure the outlet is always "live" so it cannot be switched off by mistake.

NOTE: The electrical outlet you plug the transformer into must be indoors, protected from weather.

RINSE OUT CARBON FINES

Small particles of carbon filtration material are generated during manufacturing and shipping, which will exit the media tank with the first water flow. These carbon "fines" are not harmful, but give the water a gray color and should be rinsed down the drain before any water from the softener is directed to the home's faucets or water heater.

CAUTION: To avoid water or air pressure damage to softener inner parts, and to flush pipe chips or other residue from the water pipes, be sure to do the following steps exactly as instructed.

1. Make sure the softener's valve drain hose is hooked up and the open end directed to a floor drain, laundry tub or other suitable type of drain.
2. The system should be connected to electrical power.
3. Place bypass valve(s) in "bypass" position (see Figures 13 & 14). On a single valve, slide the stem inward to bypass. On a 3-valve bypass, close the inlet and outlet valves and open the bypass valve.
4. Fully open the house main water pipe shutoff valve.
5. Initiate a regeneration by pressing and holding for 3 seconds the REGENERATION button (see Figure 15 on page 13). The valve motor will start running and the valve will advance to the "Fill" position.
6. After you hear the valve motor stop running (valve in "Fill" position), press, but do not hold, the REGENERATION button. The valve will advance to the "Brine" position.
7. After you hear the valve motor stop running (valve in "Brine" position), press, but do not hold, the REGENERATION button. The valve will advance to the "Backwash" position.
8. Once the unit is in backwash, place bypass valve(s) in SERVICE, EXACTLY as follows:
 - a. Single Bypass Valve: Slowly, slide pull the valve stem outward toward service, pausing several times to allow the softener to pressurize gradually.
 - b. 3-Valve Bypass: Fully close the bypass valve and open the outlet valve. Slowly open the inlet valve, pausing several times to allow the softener to pressurize gradually.
9. Let the softener complete the backwash and fast rinse cycles (takes about 20 minutes). When the regeneration ends, the softener's valve returns to the service position.

Installation

LEAK TEST

To check for leaks, complete the following steps:

1. Fully open two nearby cold water faucets downstream from the softener.
2. Observe steady water flow from both open faucets.
3. After about three minutes, open a hot water faucet for about one minute, or until all air is expelled, then close.
4. Close both cold water faucets.
5. Check your plumbing work for leaks, and fix right away if any are found. Be sure to observe previous caution notes.

NOTE: If this procedure is performed on a new softener, water coming from the taps may initially be discolored. This normally occurs the first time water runs through the resin bed. The discolored water is not harmful, and the discoloration will not last more than a few minutes.

RESTART THE WATER HEATER

Turn on the gas (or electric) supply to the water heater and light the pilot.

YOUR PLUMBING INSTALLATION AND ELECTRICAL WORK ARE NOW COMPLETE.

SINGLE BYPASS VALVE

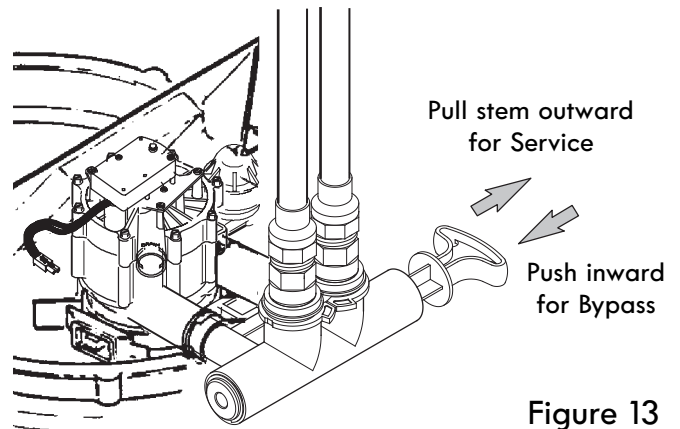

Figure 13

3-VALVE BYPASS

FOR SERVICE
Close bypass valve.
Open inlet & outlet valves.

FOR BYPASS
Open bypass valve.
Close inlet & outlet valves.

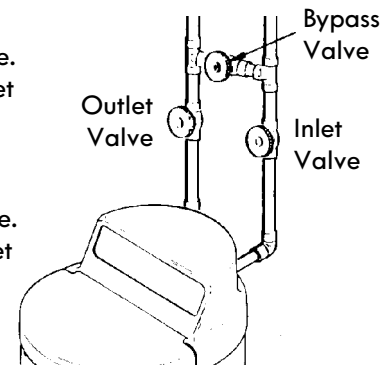

Figure 14

Programming the Softener

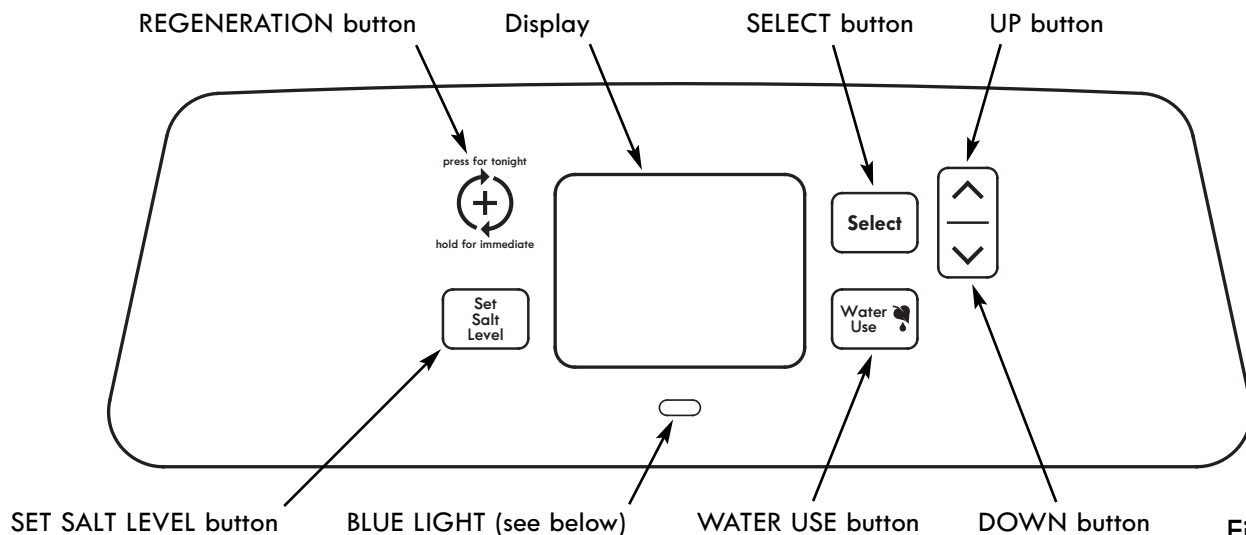

Figure 15

BLUE LIGHT

When the Kenmore Elite® Hybrid Water Softener is connected to electrical power, the blue light on the control panel will be on or flashing, as follows:

- **Blue light flashing rapidly, with “PRESENT TIME” shown in the display and the clock flashing slowly** - The present time needs to be set, either during initial start up or after a long power outage. See “Set Present Time of Day”, at right.
- **Blue light flashing slowly, along with the salt level indicators in the display** - The salt monitor system indicates a low salt level and needs to be set. See “Salt Monitor System” on Page 17.
- **Blue light flashing rapidly, with “Err” shown in the display** - The electronic self-diagnostics have detected a problem. See “Troubleshooting” on Page 22.
- **Blue light on steady (not flashing)** - The system has power applied and does not require any attention.

PROGRAM THE SOFTENER

When the transformer is plugged into the electrical outlet, the model code (520) and a test number (example: J3.0), are briefly shown in the display. Then the words “PRESENT TIME” appear and 12:00 PM begins to flash.

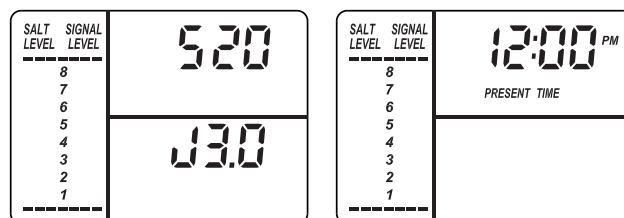

Figure 16

SET PRESENT TIME OF DAY

If the words “PRESENT TIME” do not show in the display, press the SELECT button a few times until they do.

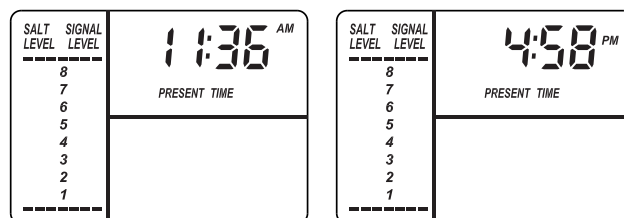

Figure 17

1. Press the Δ UP or ∇ DOWN buttons to set the present time. Up moves the display ahead; down sets the time back. Be sure AM or PM is correct.

NOTE: Press buttons and quickly release to slowly advance the display. Hold the buttons down for fast advance.

2. When the correct time is displayed, press the SELECT button, and the display will change to show the “Hardness” screen.

continued on next page

Programming the Softener

SET WATER HARDNESS NUMBER

If you completed the previous step, the word "HARDNESS" should show in the display. Otherwise, press the SELECT button several times until it does.

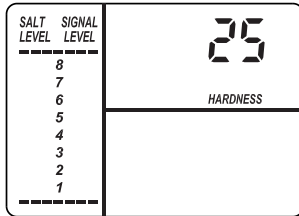

Figure 18

1. Press the \triangle UP or ∇ DOWN buttons to set the hardness of your water supply, in grains per gallon. The default is 25.

NOTE: If your water supply contains iron, compensate for it by adding to the water hardness number. For example, assume your water is 20 gpg hard and contains 2 ppm iron. Add 5 to the hardness number for each 1 ppm of iron. In this example, you would use 30 for your hardness number.

$$\begin{array}{r}
 20 \text{ gpg hardness} \\
 2 \text{ ppm iron} \times 5 = 10 \quad +10 \\
 \text{(times)} \qquad \qquad \qquad 30 \text{ HARDNESS NUMBER}
 \end{array}$$

If your water supply contains iron, it is recommended that you clean your water softener resin bed at least every 6 months. Your local Sears store has Water Softener Cleaner (Part Number 34427) available.

2. When finished setting your water's hardness number, press the SELECT button, and the display will change to show the "Recharge Time" screen.

SET RECHARGE (REGENERATION) START TIME

If you completed the previous step, the words "RECHARGE TIME" should show in the display. Otherwise, press the SELECT button several times until they do.

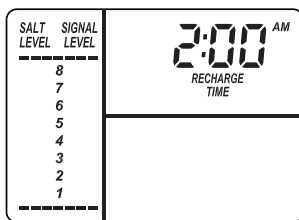

Figure 19

1. The softener's default recharge start time is 2:00 AM. This is normally a time of day when water is not being used in the household. Hard water bypasses the softener if the household draws water during the recharge cycle. If a different recharge start time is desired, press the \triangle UP or ∇ DOWN buttons to change the time, in 1-hour increments. Be sure AM or PM is correct.
2. When the desired recharge start time is displayed, press the SELECT button, and the display will change to show one of the "Salt Type" screens shown below.

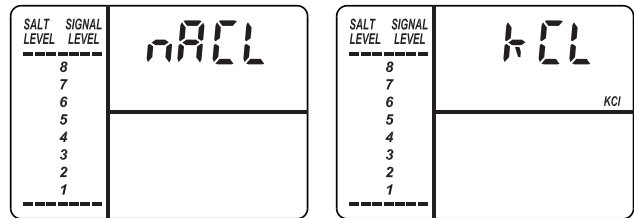

Figure 20

SET SALT TYPE

If you completed the previous step, either "NaCl" (for Sodium Chloride) or "KCl" (for Potassium Chloride) should show in the display. Otherwise, press the SELECT button several times until one of them does.

1. Press the \triangle UP or ∇ DOWN buttons to set the type of salt you will be using in your water softener. The default is NaCl (standard Sodium Chloride water softener salt). If you will be using KCl (Potassium Chloride) instead, be sure to set salt type to KCl. This setting adjusts the regeneration cycle times to compensate for the different rate at which KCl dissolves. See also the following page for more information on salt types.
2. When the correct salt type is displayed, press the SELECT button, and the display will return to the normal run (time of day) screen.

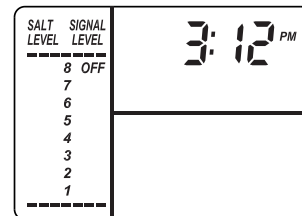

Figure 21

Flushing the System

After all installation steps have been completed:

1. Make sure the bypass valve(s) is in the “service” (open) position.
2. **Start a recharge:** Press the REGENERATION button and hold for 3 seconds, until “RECHARGE”, “Serv” and “Fill” begin to flash in the display. The recharge will take about 2 hours to complete.
3. After the recharge has completed, fully open a cold water faucet, downstream from the softener, and allow 50 gallons of water to pass through the system. This should take at least 20 minutes.
4. Close the faucet.

Your new Sears softener is now softening the water for your household needs. However, your **WATER HEATER is filled with hard water**. To have fully soft water right away, you can drain the water heater so it refills with soft water. If you don't drain the water heater, it will take a few days before you have fully soft water.

NOTE: If this procedure is performed on a new softener, water coming from the taps may initially be discolored. This normally occurs the first time water runs through the resin bed. The discolored water is not harmful, and the discoloration will not last more than a few minutes.

Adding Salt to the Storage Tank

ADDING SALT TO THE STORAGE TANK

You must keep salt in the tank, but it is not necessary to fill it full. Especially in humid areas, it is best to fill the storage tank no more than half full, and to add salt more often. Salt “bridging” occurs more often when conditions are humid.

Use NUGGET or PELLET water softener salt. **DO NOT** use rock salts, as they have dirt and sediments that will stop the softener from working. To maintain optimum performance of your water softener, the salt tank should be cleaned out every 2 to 3 years.

POTASSIUM CHLORIDE (KCl) SALT

If you choose Potassium Chloride (KCl) as a regenerant, following these suggestions will help give you years of maintenance free service.

1. Place only one bag of KCl in your softener at a time (the salt storage tank should contain no more than 60 pounds of KCl at any one time).
2. A softener using KCl should not be placed in areas with temperature fluctuations and high humidity (KCl will harden in these environments and may make the softener inoperable).
3. Check the brine tank and brinewell (black tube in salt storage tank) monthly. If hardening is present, pour small amounts of warm water onto hardened areas until they loosen.

4. Be sure to set “Salt Type” on the controller to “KCl”. This setting adjusts the regeneration cycle times to compensate for the different rate at which KCl dissolves. See “Set Salt Type” on the previous page.

Persons who are on sodium restricted diets should consider the added sodium as part of their overall sodium intake. For example, if your water supply is 15 grains hard, and you drank 3 quarts of softened water you would consume 335 milligrams of sodium. That is equivalent to eating 2-1/2 slices of white bread.

Persons who are concerned about their drinking water should consider a Kenmore reverse osmosis drinking water system that will remove in excess of 90% of the sodium and other drinking water contaminants.

WATER SOFTENING SALT WITH IRON REMOVING ADDITIVES

Some salts have an additive to help the softener handle iron in the water supply. These salts may be used if your water supply has a high iron content. It is recommended to use Sears Water Softener Cleaner (refer to the parts list in back of manual for part number) for periodic treatments to keep your resin bed clean. This is available at your local Sears store.

What Your Hybrid Water Softener Will Do

The Kenmore Elite® Hybrid Water Softener has been designed to include two different types of media, a high quality media that reduces tastes and odors and a high efficiency media to remove hardness minerals.

This Hybrid Water Softener will provide you and your home all the benefits of soft water, while providing whole home chlorine taste and odor reduction and barium and radium 226/228 reduction. You can have fil-

tered water from your kitchen faucet for food preparation and drink, in the bath and shower which will reduce chlorine's aesthetic effect on your skin and hair, and at every bathroom sink for brushing your teeth. There are no filters to change.

Based on NSF-tested rated capacity under NSF/ANSI Standard 42*, the Kenmore Elite® Hybrid Water Softener has an estimated useful life for chlorine taste and odor reduction of over 10 years.

*NSF rated capacity is 570,000 gallons.

Controller Features

EXTRA RECHARGE

Sometimes, a manually initiated recharge (regeneration) may be desired, or needed. Two examples are:

- You have used more water than usual (guests visiting) and you may run out of soft water before the next automatic regeneration.
- You did not add salt to the softener before it ran out. Add salt to the softener before regenerating.

You can start a regeneration immediately, or you can set the controller to regenerate at the next preset recharge time (2:00 AM, or as set).

RECHARGE NOW

Press the REGENERATION button and hold for 3 seconds, until the words "RECHARGE", "Serv" and "Fill" begin to flash in the display. The softener enters the fill cycle of regeneration immediately. This regeneration will take about 2 hours to complete. Then, you will have soft water again.

NOTE: If the "Clean Feature" is set ON, the normal regeneration cycle is preceded by a cleaning backwash and rinse. The words "CLEAN" and "Bkwsh" or "Rinse" flash in the display, along with the minutes of the clean cycle remaining.

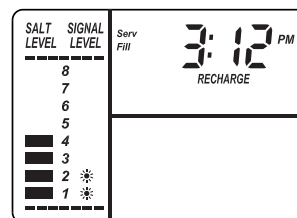

Figure 22

RECHARGE TONIGHT

Press and release (do not hold) the REGENERATION button. "RECHARGE TONIGHT" will begin flashing in the display, and the softener will begin regeneration at the next preset recharge time (2:00 AM, or as set). If you decide to cancel the regeneration before it starts, press and release the REGENERATION button once more. "RECHARGE TONIGHT" will stop flashing in the display.

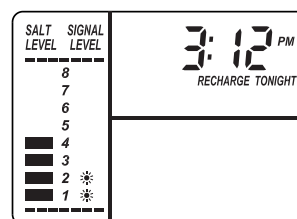

Figure 23

Controller Features

SALT MONITOR SYSTEM

The water softener has a blue light that will flash to remind you to add salt to the storage tank.

NOTE: You must set salt level each time salt is added to the water softener.

NOTE: The salt monitor system estimates salt levels, and accuracy will vary with different salts.

To set this monitor system:

1. Lift the salt lid and level the salt in the storage tank.
2. The yellow salt level decal, on the brinewell inside the tank, has numbers from 0 to 8 (see Fig. 24). Observe the highest number the leveled salt is at, or closest to.

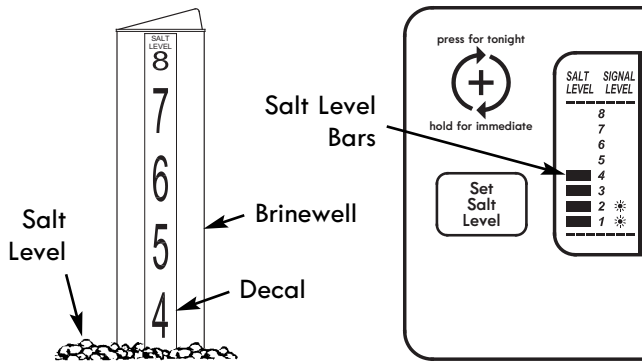

Figure 24

3. Press the SET SALT LEVEL button as many times as necessary to make the salt level bars in the display (see Fig. 24) match the number on the decal. At level 2 or below, the salt level bars, signal level indicators and blue light will flash.
4. If you want to turn the salt monitor off, press the SET SALT LEVEL button past 8, until "OFF" shows in the display next to the number 8.

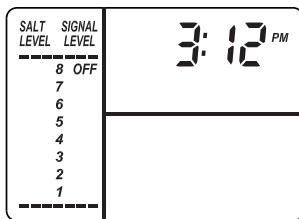
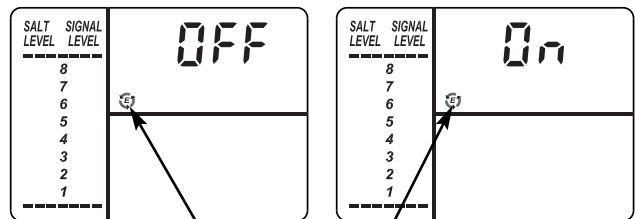

Figure 25

OPTIONAL SETTINGS:

- SALT EFFICIENCY
- CLEAN FEATURE
- CLEAN FEATURE MINUTES
- 97% FEATURE
- 12 / 24 HOUR CLOCK
- GALLONS / LITERS
- MAXIMUM DAYS BETWEEN REGENERATIONS
- BACKWASH & FAST RINSE TIMES

1. To set any of these options, press and hold SELECT for 3 seconds until "000" shows in the display. Then press (do not hold) SELECT again to display one of the "Salt Efficiency" screens shown below.



Efficiency Icon

Figure 26

SALT EFFICIENCY: When this feature is ON, the water softener will operate at salt efficiencies of 4000 grains of hardness per pound of salt or higher. The softener may recharge more often using smaller salt dosage and less water. This softener is shipped with the efficiency feature set OFF. **Installations in the State of California require this setting to be turned ON.** Use the Δ UP or ∇ DOWN buttons to change between OFF and ON.

California Efficiency Requirement

Your Kenmore Water Softener has a "High Efficiency" feature that can be set ON or OFF. This softener is shipped with the efficiency feature set OFF, which will utilize the maximum rated capacity while most often achieving maximum salt efficiencies. When installing this unit in the State of California, you **MUST** turn the efficiency feature ON. The softener may initiate more frequent recharges, but it will operate at 4000 grains per pound of salt or higher.

Controller Features

2. Press SELECT again to display one of the “Clean” screens shown below.

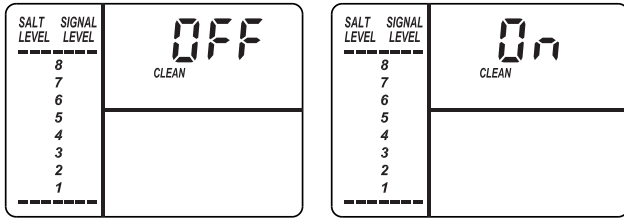

Figure 27

CLEAN: This feature is beneficial on water supplies containing iron and/or high amounts of sediments (sand, silt, dirt, etc.). When set to ON, a backwash and fast rinse cycle will occur first, preceding the normal regeneration sequence. This provides extra cleaning of the resin bed before it is regenerated with the salt brine. To conserve water, if your water supply does not contain iron or sediments, be sure this feature is set to OFF. The default is OFF. Use the Δ UP or ∇ DOWN buttons to change between OFF and ON.

3. Press SELECT again to display the “Clean Time” screen shown below.

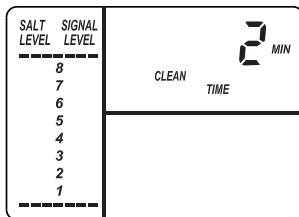

Figure 28

CLEAN FEATURE MINUTES: If you have set the Clean Feature ON, the length of the extra backwash cycle automatically is set to 2 minutes. However, you can adjust this time from 1 to 15 minutes in length. To change this cycle time, use the Δ UP button to increase the time, or the ∇ DOWN button to shorten the time. If no change is desired, continue to next step.

4. Press SELECT again to display the “97%” screen.

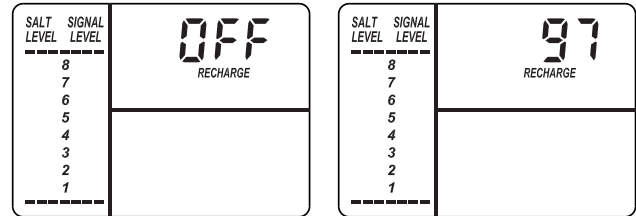

Figure 29

97% FEATURE: The 97% Feature can save salt and water by regenerating when 97% of the softener’s capacity has been used up. With this feature ON, the regeneration can occur at any time (whenever the system has reached 97% of its capacity). The default is OFF. If this feature is desired, turn it on by pressing the Δ UP button.

5. Press SELECT again to display the “12 or 24 hr” screen.

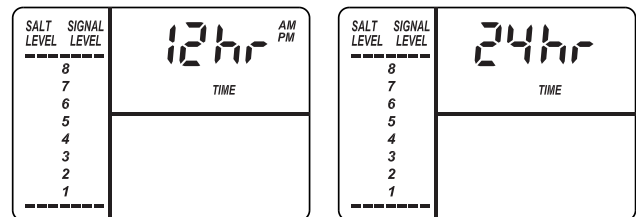

Figure 30

12 OR 24 HOUR CLOCK: All time displays are shown in standard clock time (1 to 12 AM; and 1 to 12 PM) at the 12 hr default setting. If 24 hour time format is desired, set to 24 hr by pressing the Δ UP button.

Controller Features

6. Press SELECT again to display the “Gallons or Liters” screen.

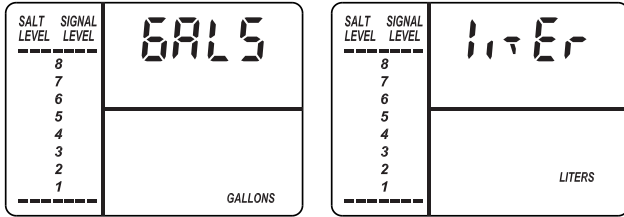

Figure 31

GALLON OR LITER READINGS: Water usage and flow rate displays are shown in gallons at the default setting. If you prefer liters, change this setting from “Gals” to “Liter” by pressing the Δ UP button.

7. Press SELECT again to display the “Recharge Days” screen.

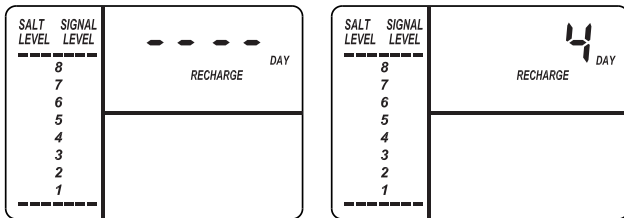

Figure 32

MAXIMUM DAYS BETWEEN REGENERATIONS: The electronic controller automatically determines regeneration frequency. This provides the greatest operating efficiency and, under most conditions this feature will be left in its default mode. However, you can set this feature to force a regeneration every set number of days. You may want to do this if, for example, your water supply contains iron and you want the softener to regenerate at least once every few days to keep the resin bed clean. Use the Δ UP or ∇ DOWN buttons to change the number of days (up to 15). If no change is desired, continue to next step.

8. Press SELECT again to display the “Backwash Time” setting screen.

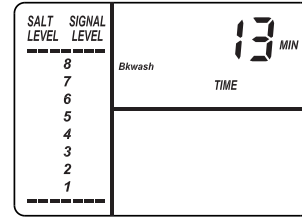

Figure 33

BACKWASH & FAST RINSE TIMES: If you experience salty tasting water after regeneration, you may need to increase the backwash and fast rinse times. The default backwash time is 13 minutes and the default fast rinse time is 6 minutes. However, you may increase or decrease the backwash and fast rinse times, in 1 minute increments.

If you wish to change the backwash time, use the Δ UP or ∇ DOWN buttons to set the backwash time between 1 and 30 minutes. Then press SELECT to display the “Fast Rinse Time” setting screen.

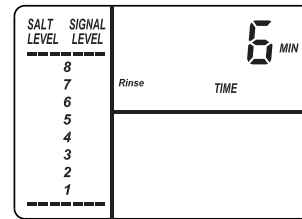

Figure 34

If you wish to change the fast rinse time, use the Δ UP or ∇ DOWN buttons to set the fast rinse time between 1 and 30 minutes.

9. Press SELECT to return to the normal run (time of day) screen.

TANK LIGHT

A light inside the salt storage tank will come on whenever you open the salt lid. A “Tank Light” icon is displayed when this light is on. The light turns off when you close the salt lid. It will also turn off automatically after 15 minutes if the salt lid is left open.

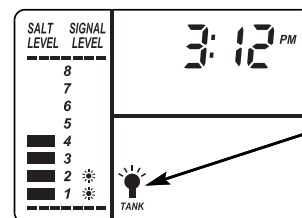

Tank Light Icon

Figure 35

Controller Features

WATER FLOW THROUGH THE SOFTENER

To view the flow rate through the softener in gallons (or liters) per minute, press the WATER USE button. If soft water is in use, the flow rate will be displayed to the nearest tenth of a gallon (or liter). The display will show "0" when all faucets and water using appliances are off.

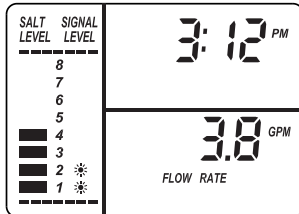

Figure 36

AVERAGE DAILY GALLONS OR LITERS

Press the WATER USE button a second time to display the average number of gallons (or liters) of soft water that the household uses each day. This water usage figure is recalculated daily by the electronic controller. To turn this display off, press the WATER USE button once again.

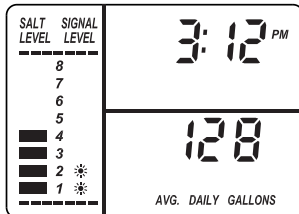

Figure 37

RECHARGE TIME REMAINING & VALVE POSITION INDICATORS

One of the valve position indicators (Serv, Fill, Brine, Bkwh, Rinse) is displayed while the softener is recharging. RECHARGE flashes in the display and, beginning with Brine, the minutes of recharge remaining before return to service appears in place of the present time. When the valve is moving from one cycle to another, both position indicators are flashing.

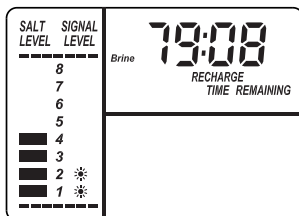

Figure 38

PROGRAM MEMORY

If electrical power to the softener goes off, the time display is blank but the electronic controller keeps the correct time for several hours. When electrical power comes on again, you will have to reset the present time only if the display is flashing. The HARDNESS and RECHARGE TIME never require resetting unless a change is desired. Even if the clock is incorrect after a long power outage, the softener works as it should to keep your water soft, however, regenerations may occur at the wrong time of day until you reset the clock to the correct time of day.

KENMORE'S ULTRA CLEANSING FEATURE

The ultra cleansing feature keeps larger particles of sediment from entering the home's plumbing system. As water passes through the softener, the larger sediment particles are collected in the integrated basket and then rinsed to the drain before each regeneration. The ultra cleansing feature provides added protection for water using appliances by reducing the chance of larger particles entering the various products valves and screens. The "Clean Feature" may be turned ON to provide an extra backwash that will help keep the ultra cleansing screen clean. The default is OFF.

IMPORTANT: The ultra cleansing feature is not intended to replace pretreatment filtration. For problem water applications, additional sediment filtration is recommended.

Sears offers a full line of dedicated sediment filtration products.

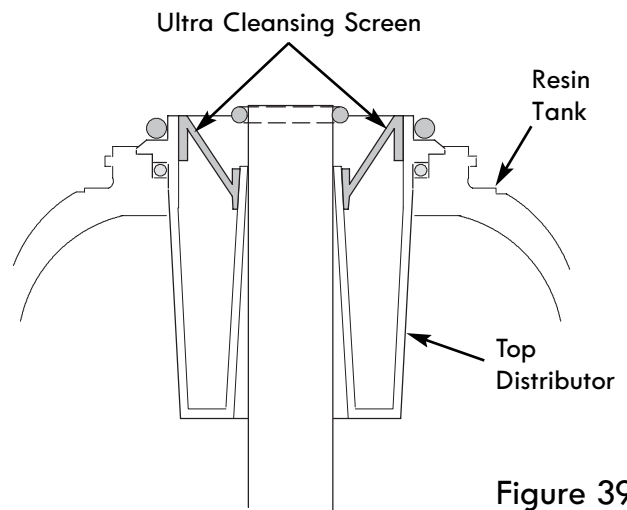

Figure 39

Care of Your Water Softener

SALT BRIDGE

Sometimes, a hard crust or salt "bridge" forms in the brine tank. It is usually caused by high humidity or the wrong kind of salt. When the salt "bridges," an empty space forms between the water and the salt. Then, salt will not dissolve in the water to make brine. Without brine, the resin bed is not recharged and hard water will result.

If the storage tank is full of salt, it is difficult to tell if you have a salt bridge. A bridge may be underneath loose salt. Take a broom handle, or like tool, and hold it next to the water softener. Measure the distance from the floor to the rim of the water softener. Then, gently push the broom handle straight down into the salt. If a hard object is felt before the pencil mark is even with the top, it is most likely a salt bridge. Gently push into the bridge in several places to break it. Do not use any sharp or pointed objects as you may puncture the brine tank. Do not try to break the salt bridge by pounding on the outside of the salt tank. You may damage the tank.

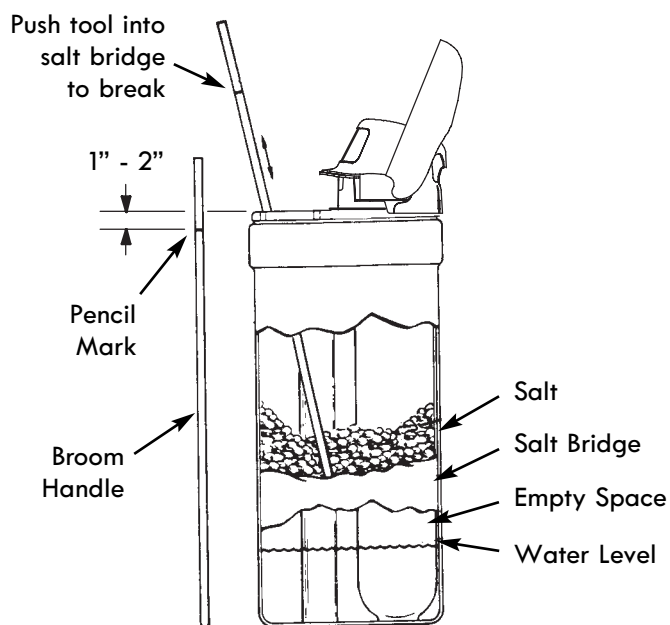

Figure 40

Service Information

ALWAYS MAKE THESE INITIAL CHECKS FIRST

1. Does the time display show the correct time of day?
 - If display is blank, check power source to the softener.
 - If time is flashing, power was off for a long period. The softener resumes normal operation but regenerations occur at the wrong time.
 - If an error code (example: "Err3") shows in the display, go to "Troubleshooting".
2. Are bypass valve(s) fully in service position?
3. Are the inlet and outlet pipes connected to the softener inlet and outlet respectively?
4. Is the softener's transformer plugged into a "live", grounded wall outlet, and the power cable fastened securely to the controller?
5. Is the valve drain hose free of kinks and sharp bends, and not elevated more than 8 ft. above the floor?
6. Is there salt in the storage tank?
7. Is the brine tubing connected? Brine tubing connects to nozzle/venturi and brine valve assembly.
8. Press the SELECT button twice to display the hardness setting. Make sure it is correct for the household's water supply. Perform a hardness test of the untreated incoming water and compare with the hardness setting. Also test a soft water sample to verify if a problem exists. Press the SELECT button several more times to return to present time display.

Service Information

TROUBLESHOOTING

If your water softener does not work properly, make the following easy checks. Often, you will find what is wrong yourself and you won't have to call and wait for service. If you do not find anything wrong while making the checks, and your softener still does not work properly, call your Sears Service Department.

PROBLEM	CAUSE	CORRECTION
No soft water	No salt in the storage tank.	Add salt and then use RECHARGE NOW feature.
No soft water & display is blank	Transformer unplugged at wall outlet, or power cable disconnected from back of electronic board or transformer malfunction.	Check for loss of power and correct. Reprogram electronic control and then use RECHARGE NOW feature.
	Fuse blown, circuit breaker tripped, or circuit switched off (see "Power Outage Memory").	Replace fuse, reset circuit breaker, or switch circuit on, and then use RECHARGE NOW feature.
No soft water & salt level not dropping	Salt storage tank "bridged".	Refer to "Breaking a Salt Bridge".
	Bypass valve(s) in "bypass" position.	Move bypass valve(s) to "service" position.
No soft water & salt storage tank full of water	Dirty, plugged or damaged nozzle & venturi assembly	Take apart, clean and inspect nozzle & venturi (see instruction decal under salt lid).
	Valve drain hose is plugged or restricted.	Hose must not have any kinks, sharp bends or any water flow blockage (See "Valve Drain Requirements").
Intermittent hard water	Incorrect time set.	Check and change time setting.
	Incorrect water hardness set.	Refer to "Set Water Hardness Number" to set correctly.
	Hot water being used when softener is regenerating.	Avoid using hot water while the softener is regenerating, as the water heater will fill with hard water.
	Possible increase in water hardness.	Test untreated water for hardness and iron. Program the water softener accordingly (see "Set Water Hardness Number").
Brine tank flooded	Valve drain hose is plugged or restricted.	Hose must not have any kinks, sharp bends or any water flow blockage (See "Valve Drain Requirements").
	Dirty, plugged or damaged nozzle & venturi assembly.	Take apart, clean and inspect nozzle & venturi (see "Cleaning the Nozzle & Venturi").
Salty tasting water immediately after regeneration	Backwash and fast rinse cycle times are not long enough.	Increase backwash & fast rinse times (see "Back Wash & Fast Rinse Times").
	Valve drain hose is plugged or restricted.	Hose must not have any kinks, sharp bends or any water flow blockage (see "Valve Drain Requirements").
Error code appears (example: "Err3")	Fault in electronic controller or wiring harness connections to position switch, position switch inoperable or motor inoperable.	Unplug power cord. Check all wiring connections to be sure they are secure. Plug in power cord and wait 8 minutes. If error code returns, call Kenmore Water Line.

Questions? Call the Kenmore Water Line 1-800-426-9345 or visit www.kenmorewater.com

Service Information

MANUALLY INITIATED ELECTRONIC DIAGNOSTICS

- To enter diagnostics, press the SELECT button and hold for three seconds. The display will change to show turbine count, valve cycle position, and position switch status (open or closed).

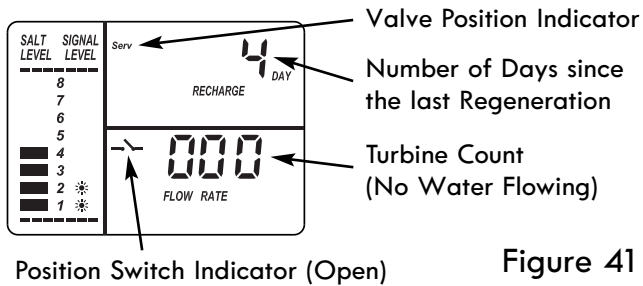

Figure 41

TURBINE OPERATION: If no water is flowing through the softener, the turbine indicator displays three zeros. When water is flowing, a 000 to 140 count repeats for each gallon of water passing through the turbine. To check for positive operation of the turbine if zeros are shown, open a nearby soft water faucet and observe the turbine count. If you don't get a reading in the display with faucet open, pull the sensor housing from the valve outlet port (see Fig. 43). Pass a small magnet back and forth in front of the sensor. You should get a reading in the display. If you get a reading, unhook the inlet and outlet plumbing and check the turbine for binding.

POSITION SWITCH STATUS: With the valve in service, or any of the recharge cycle positions, the position switch indicator will show the switch open. While the valve is rotating from one position to another, the position switch indicator will show the switch closed. There is likely a problem if indications vary from this pattern.

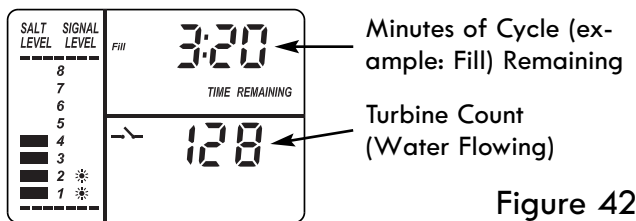

Figure 42

OTHER INFORMATION: While in the diagnostics screen, the following information is available and may be beneficial for various reasons. This information is retained by the electronic controller from the first time electrical power is applied to the unit.

- Press and hold the \triangle UP button to display the number of days this controller has had electrical power applied.

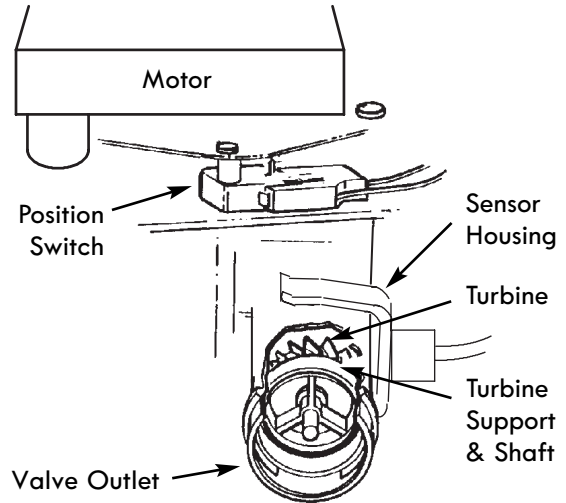

Figure 43

- Press and hold the ∇ DOWN button to display the number of regenerations initiated by this controller since the model code number was entered.

NOTE: If the electronic controller is left in the diagnostic display (or a flashing display when setting times or hardness), the normal time of day display automatically returns if a button has not been pressed for 4 minutes. To return to the diagnostic display, repeat step 1, above.

RESETTING TO FACTORY DEFAULTS

To reset the electronic controller to its factory default for all settings (time, hardness, etc.):

- Press the SELECT button and hold it until the display changes twice to show the flashing model code.
- Press the \triangle UP button to display a flashing "SoS".

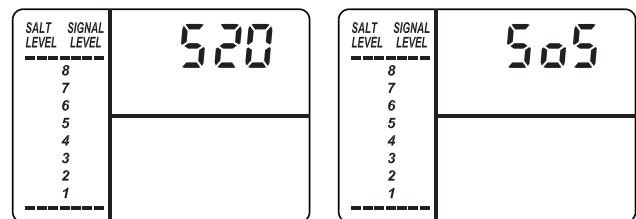

Figure 44

- Press the SELECT button, and the electronic controller will restart.
- Set the present time, hardness, etc., as described on pages 13 & 14.

Service Information

MANUAL ADVANCE REGENERATION CHECK

This check verifies proper operation of the valve motor, brine tank fill, brine draw, regeneration flow rates, and other controller functions. Always make the initial checks first, and perform the manually initiated electronic diagnostics.

NOTE: The display must show a steady time (not flashing). If an error code shows, first press the SELECT button to enter the diagnostic display.

1. Press the REGENERATION button and hold in for 3 seconds. "RECHARGE", "Serv" and "Fill" begin to flash in the display as the softener enters the fill cycle of regeneration.
2. When valve reaches "Fill" position, remove the brinewell cover and, using a flashlight, observe fill water entering the tank.
3. If water does not enter the tank, look for an obstructed nozzle, venturi, fill flow plug, brine tubing, or brine valve riser pipe.
4. After observing fill, press the REGENERATION button to move the softener into brining. A slow flow of water to the drain will begin. Verify brine draw from the brine tank by shining a flashlight into the brinewell and observing a noticeable drop in the liquid level.
5. If the softener does not draw brine:
 - nozzle and/or venturi dirty
 - nozzle and venturi not seated properly on gasket
 - restricted drain (check drain fitting and hose)
 - ineffective nozzle and venturi seal
 - other inner valve problem (rotor seal, rotor & disc, wave washer, etc.)

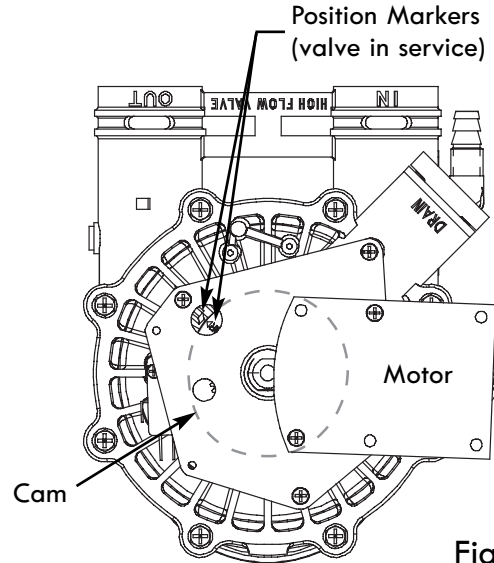

Figure 45

NOTE: If water system pressure is low, an elevated drain hose may cause back pressure, stopping brine draw.

6. Again press REGENERATION to move the softener into backwash. Look for a fast flow of water from the drain hose.
7. An obstructed flow indicates a plugged top distributor, backwash flow plug or drain hose.
8. Press REGENERATION to move the softener into fast rinse. Again look for a fast drain flow. Allow the softener to rinse for a few minutes to flush out any brine that may remain in the resin tank from the brining cycle test.
9. To return the softener to service, press REGENERATION once more.

Service Information

WIRING SCHEMATIC

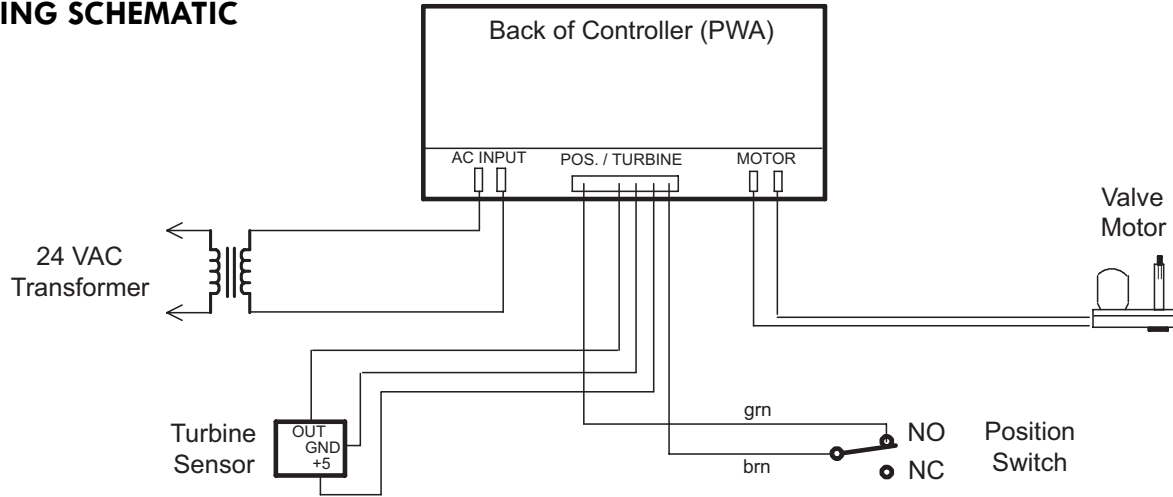
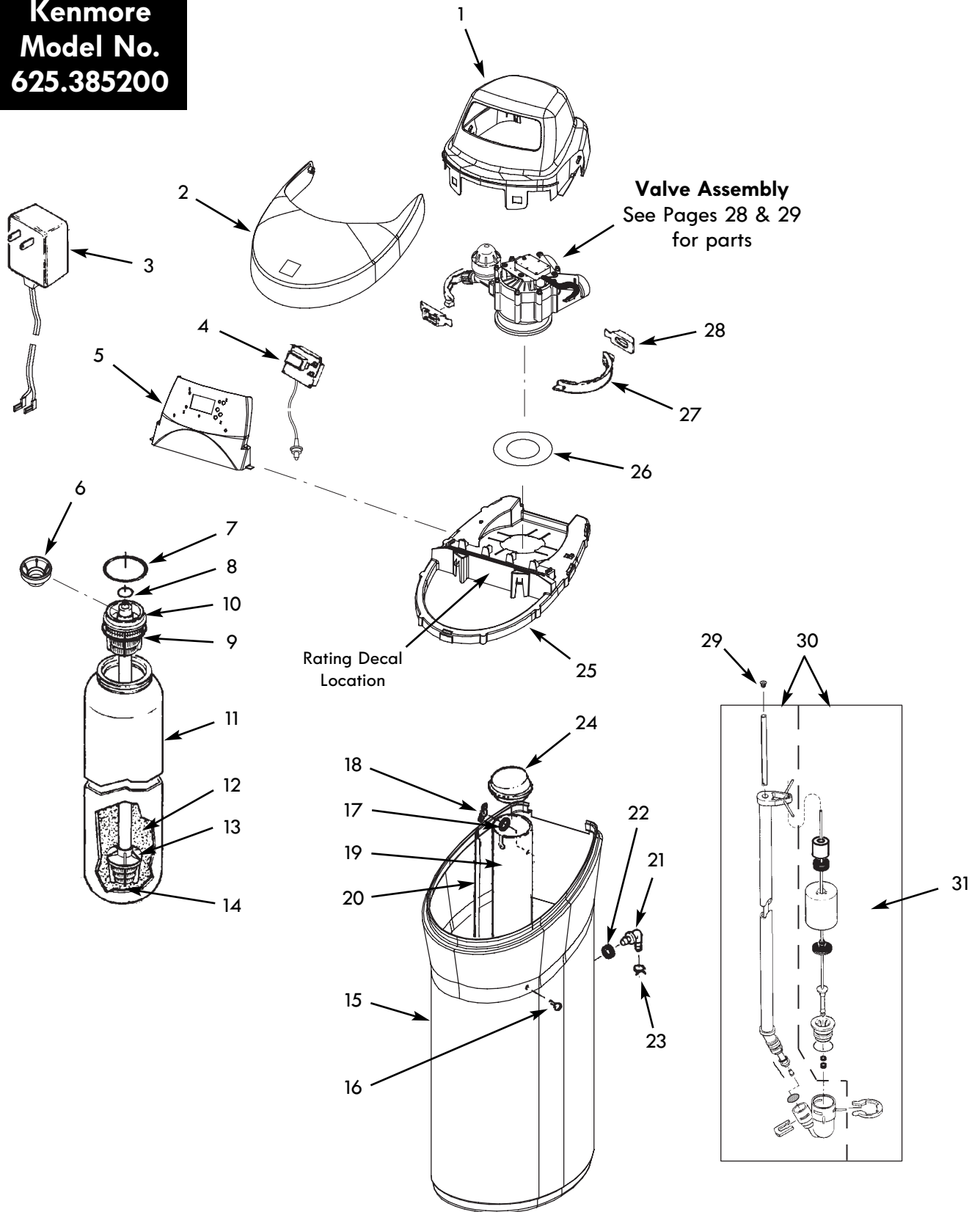

Figure 46

Water Softener Exploded View

**Kenmore
Model No.
625.385200**



Questions? Call the Kenmore Water Line 1-800-426-9345 or visit www.kenmorewater.com

Softener Parts List

Key No.	Part No.	Description
1	7329803	Top Cover
2	7330600	Salt Lid (includes Kenmore badge & instruction decal)
3	7275907	Transformer, 24V, 10VA
4	7329942	Repl. Electronic Controller (PWA)
5	7330626	Faceplate (includes faceplate decal)
6	7265025	Ultra Cleansing Screen
-	7112963	Distributor O-Ring Kit (includes Key Nos. 7-9)
7	↑	O-Ring, 2-7/8" x 3-1/4"
8	↑	O-Ring, 13/16" x 1-1/16"
9	↑	O-Ring, 2-3/4" x 3"
10	7077870	Top Distributor
11	7247996	Repl. Resin Tank, 10" x 40"
12	0502272	Resin
	7175149	Activated Carbon
13	7327584	Repl. Bottom Distributor
14	7124415	Gravel
15	7325508	Salt Storage Tank
-	7327576	Brinewell Mounting Hardware Kit (includes Key Nos. 16-18)
16	↑	Screw, 1/4-20 x 5/8"
17	↑	O-Ring, 1/4" x 1/2"
18	↑	Wing Nut, 1/4-20

Key No.	Part No.	Description
-	7214375	Brinewell Assembly (includes Key Nos. 19 & 20)
19	↑	Brinewell
20	↑	Decal, Salt Level
-	7331258	Overflow Hose Adaptor Kit (includes Key Nos. 21-23)
21	↑	Adaptor Elbow
22	↑	Grommet
23	↑	Hose Clamp
24	7219888	Brinewell Cover
25	7325396	Rim
26	7232446	Vapor Barrier
-	7331177	Tank Neck Clamp Kit (includes 2 ea. of Key Nos. 27 & 28)
27	↑	Clamp Section (2 req.)
28	↑	Retainer Clip (2 req.)
29	7171349	Cone Screen
30	7310202	Brine Valve Assembly
31	7327568	Float, Stem & Guide Assembly
■	3442707	Water Softener Cleaner *
■	7278581	Parts Bag (includes 4 ea. of Key Nos. 70 & 72, 3 ea. of Key No. 71, 2 ea. of Key No. 23, 1 ea. of Key Nos. 21 & 22)
■	7332880	Owner's Manual

■ Not illustrated.

* Not included with water softener.

Valve Assembly Exploded View

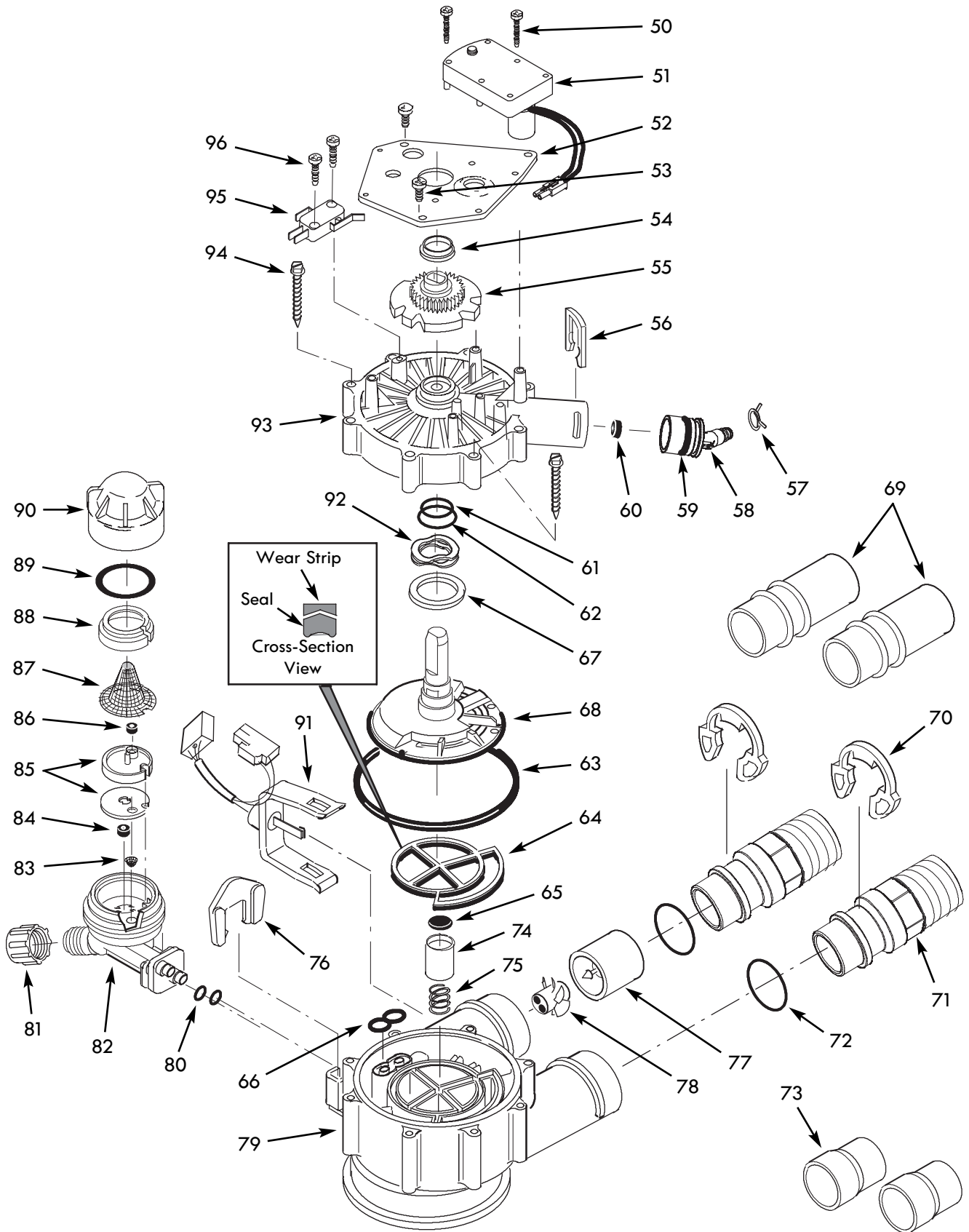

Questions? Call the Kenmore Water Line 1-800-426-9345 or visit www.kenmorewater.com

Valve Parts List

Key No.	Part No.	Description
50	7224087	Screw, #8-32 x 1" (2 req.)
51	7286039	Motor (incl. 2 ea. of Key No. 50)
52	7231393	Motor Plate
53	0900857	Screw, #6-20 x 3/8" (2 req.)
54	7171250	Bearing
55	7283489	Cam & Gear
-	7331169	Drain Hose Adaptor Kit (incl. Key Nos. 56-60)
56	↑	Clip, Drain
57	↑	Hose Clamp
58	↑	Adaptor, Drain Hose
59	↑	O-Ring, 15/16" x 1-3/16"
60	↑	Flow Plug, 2.0 gpm
-	7185487	Seal Kit (includes Key Nos. 61-66)
61	↑	O-Ring, 5/8" x 13/16"
62	↑	O-Ring, 1-1/8" x 1-1/2"
63	↑	O-Ring, 4-1/2" x 4-7/8"
64	↑	Rotor Seal
65	↑	Seal
66	↑	Seal, Nozzle & Venturi
67	7174313	Bearing, Wave Washer
68	7185500	Rotor & Disc
69	7262506	Installation Adaptor Kit, 1", (includes 2 ea. copper tubes, clips & washers) *
70	7089306	Clip (4 req.)
71	7271204	Installation Adaptor, 1" NPT (2 req.)
72	7311127	O-Ring, 1-1/16" x 1-5/16" (4 req.)
73	7232234	Copper Reducer Bushing, 1" to 3/4" (2 req.) *
74	7171187	Plug, Drain Seal

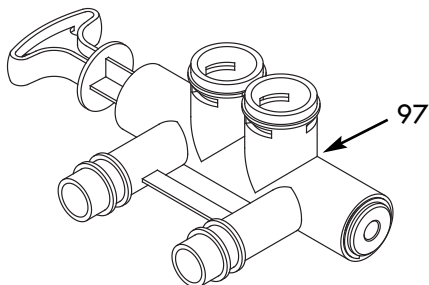

Key No.	Part No.	Description
75	7129889	Spring
76	7081201	Retainer, Nozzle & Venturi
-	7290931	Turbine & Support Assembly (includes 1 ea. of Key Nos. 77, 78 & 2 ea. of Key No. 72)
77	↑	Turbine Support & Shaft
78	↑	Turbine
79	7171145	Valve Body
80	7170319	O-Ring, 1/4" x 3/8" (2 req.)
81	1202600	Nut - Ferrule
-	7253808	Nozzle & Venturi Assembly (includes Key Nos. 82-90)
82	7081104	Housing, Nozzle & Venturi
83	7095030	Cone Screen
84	1148800	Flow Plug, 0.3 gpm
85	7114533	Nozzle & Venturi Gasket Kit
	7204362	Gasket (only)
86	7084607	Flow Plug, 0.15 gpm
87	7146043	Screen
88	7167659	Screen Support
89	7170262	O-Ring, 1-1/8" x 1-3/8"
90	7199729	Cap
91	7309811	Wire Harness (Sensor)
92	7175199	Wave Washer
93	7171161	Valve Cover
94	7172997	Screw, #10-14 x 2-5/8" (8 req.)
95	7305150	Switch
96	7140738	Screw, #4-24 x 3/4" (2 req.)
97	7214383	Bypass Valve Assembly (incl. 2 ea. of Key Nos. 70 & 72)
■	7139999	Drain Tubing, 3/8" I.D. x 20 ft.
■	7123613	Silicone Grease (for O-Rings) *
■	3479901	Adaptor Kit, 1" to 1-1/4" *
■	42-34407	Flexible Connectors, 1" *

■ Not illustrated.

* Not included with water softener.

Notes

State of California
Department of Public Health
Water Treatment Device
Certificate Number
11 - 2088
Date Issued: August 2, 2011

Trademark/Model Designation

Kenmore 625.385200

Replacement Elements

Manufacturer: Sears Brands Management Corporation

The water treatment device(s) listed on this certificate have met the testing requirements pursuant to Section 116830 of the Health and Safety Code for the following health related contaminants:

Microbiological Contaminants and Turbidity

Inorganic/Radiological Contaminants

Barium
Radium 226/228

Organic Contaminants

Rated Service Capacity: n/a

Rated Service Flow: 8 gpm

Conditions of Certification:

Do not use where water is microbiologically unsafe or with water of unknown quality, except that systems certified for cyst reduction may be used on disinfected waters that may contain filterable cysts.



FOR IOWA USE ONLY

All sales in Iowa require the following signature before consummation of sale. These signatures must be retained by seller/renter for 2 years minimum.

Buyer/Renter _____ Date _____

Seller _____ Date _____

Seller's Address _____

Seller's Phone No. _____

Model 625.385200

Get it fixed, at your home or ours!

Your Home

For expert troubleshooting and home solutions advice:



www.managemylife.com

For repair – **in your home** – of **all** major brand appliances, lawn and garden equipment, or heating and cooling systems, **no matter who made it, no matter who sold it!**

For the replacement parts, accessories and owner's manuals that you need to do-it-yourself.

For Sears professional installation of home appliances and items like garage door openers and water heaters.

1-800-4-MY-HOME® (1-800-469-4663)

Call anytime, day or night (U.S.A. and Canada)

www.sears.com www.sears.ca

Our Home

For repair of carry-in items like vacuums, lawn equipment, and electronics, call anytime for the location of your nearest

Sears Parts & Repair Service Center

1-800-488-1222 (U.S.A.)

www.sears.com

1-800-469-4663 (Canada)

www.sears.ca

To purchase a protection agreement on a product serviced by Sears:

1-800-827-6655 (U.S.A.)

1-800-361-6665 (Canada)

Para pedir servicio de reparación a domicilio, y para ordenar piezas:

1-888-SU-HOGAR®

(1-888-784-6427)

www.sears.com

Au Canada pour service en français:

1-800-LE-FOYER^{MC}

(1-800-533-6937)

www.sears.ca

The Sears logo, featuring the word "Sears" in a large, bold, serif font with a stylized 'S'.

© Registered Trademark / TM Trademark of KCD IP, LLC in the United States, or Sears Brands, LLC in other countries

© Marca Registrada / TM Marca de Fábrica de KCD IP, LLC en Estados Unidos, o Sears Brands, LLC en otros países

^{MC} Marque de commerce / ^{MD} Marque déposée de Sears Brands, LLC