

**KENWOOD**

**INSTRUCTION MANUAL**

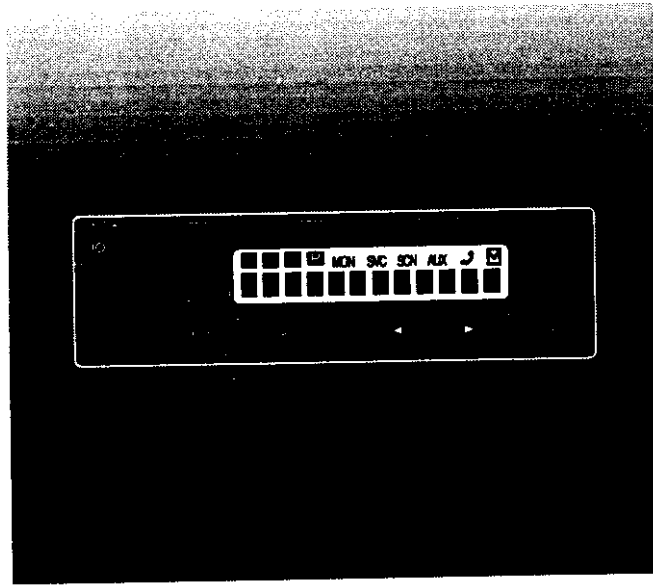

VHF FM TRANSCEIVER

**TK-780**

UHF FM TRANSCEIVER

**TK-880**

**KENWOOD CORPORATION**

© B62-0994-00 (K)  
09 08 07 06 05 04 03 02 01 00

## THANK YOU!

We are grateful you chose **KENWOOD** for your personal mobile applications. We believe this easy-to-use transceiver will provide dependable communications to keep personnel operating at peak efficiency.

**KENWOOD** transceivers incorporate the latest in advanced technology. As a result, we feel strongly that you will be pleased with the quality and features of this product.

## MODELS COVERED BY THIS MANUAL

The models listed below are covered by this manual:

- **TK-780:** VHF FM Transceiver
- **TK-880:** UHF FM Transceiver

One or more of the following statements may be applicable:

### FCC WARNING

*This equipment generates or uses radio frequency energy. Changes or modifications to this equipment may cause harmful interference unless the modifications are expressly approved in the instruction manual. The user could lose the authority to operate this equipment if an unauthorized change or modification is made.*

### INFORMATION TO THE DIGITAL DEVICE USER REQUIRED BY THE FCC

*This equipment has been tested and found to comply with the limits for a Class B digital device, pursuant to Part 15 of the FCC Rules. These limits are designed to provide reasonable protection against harmful interference in a residential installation. This equipment generates, uses and can generate radio frequency energy and, if not installed and used in accordance with the instructions, may cause harmful interference to radio communications. However, there is no guarantee that the interference will not occur in a particular installation. If this equipment does cause harmful interference to radio or television reception, which can be determined by turning the equipment off and on, the user is encouraged to try to correct the interference by one or more of the following measures:*

- Reorient or relocate the receiving antenna.
- Increase the separation between the equipment and receiver.
- Connect the equipment to an outlet on a circuit different from that to which the receiver is connected.
- Consult the dealer for technical assistance.

## NOTICES TO THE USER

- ◆ *GOVERNMENT LAW PROHIBITS THE OPERATION OF UNLICENSED RADIO TRANSMITTERS WITHIN THE TERRITORIES UNDER GOVERNMENT CONTROL.*
- ◆ *ILLEGAL OPERATION IS PUNISHABLE BY FINE OR IMPRISONMENT OR BOTH.*
- ◆ *REFER SERVICE TO QUALIFIED TECHNICIANS ONLY.*

**SAFETY:** It is important that the operator is aware of, and understands, hazards common to the operation of any transceiver.

### **WARNING!**

- ◆ **EXPLOSIVE ATMOSPHERES (GASES, DUST, FUMES, etc.)**  
*Turn OFF your transceiver while taking on fuel or while parked in gasoline service stations. Do not carry spare fuel containers in the trunk of your vehicle if your transceiver is mounted in the trunk area.*
- ◆ **INJURY FROM RADIO FREQUENCY TRANSMISSIONS**  
*Do not operate your transceiver when somebody is either touching the antenna or standing within two to three feet of it, to avoid the possibility of radio frequency burns or related physical injury.*
- ◆ **DYNAMITE BLASTING CAPS**  
*Operating the transceiver within 500 feet of dynamite blasting caps may cause them to explode. Turn OFF your transceiver when in an area where blasting is in progress, or where "TURN OFF TWO-WAY RADIO" signs have been posted. If you are transporting blasting caps in your vehicle, make sure they are carried in a closed metal box with a padded interior. Do not transmit while the caps are being placed into or removed from the container.*

## PRECAUTIONS

Please observe the following precautions to prevent fire, personal injury, and transceiver damage.

- Do not attempt to configure the transceiver while driving; it is too dangerous.
- Do not modify the transceiver for any reason.
- Do not expose the transceiver to long periods of direct sunlight, nor place it near heating appliances.
- Do not place the transceiver in excessively dusty, humid, or wet areas, not on unstable surfaces.
- If an abnormal odor or smoke is detected coming from the transceiver, turn OFF the power immediately. Contact your **KENWOOD** dealer.

## CONTENTS

<b>UNPACKING AND CHECKING EQUIPMENT .....</b>	<b>1</b>
<b>SUPPLIED ACCESSORIES .....</b>	<b>1</b>
<b>PREPARATION .....</b>	<b>2</b>
<b>TOOLS REQUIRED .....</b>	<b>2</b>
<b>POWER CABLE CONNECTION .....</b>	<b>2</b>
<b>INSTALLING THE TRANSCEIVER .....</b>	<b>3</b>
<b>ORIENTATION .....</b>	<b>4</b>
<b>FRONT PANEL AND MICROPHONE .....</b>	<b>4</b>
<b>DISPLAY .....</b>	<b>5</b>
<b>REAR PANEL .....</b>	<b>5</b>
<b>PROGRAMMABLE AUXILIARY FUNCTIONS .....</b>	<b>6</b>
<b>BASIC OPERATIONS .....</b>	<b>8</b>
<b>OPERATION OVERVIEW .....</b>	<b>8</b>
Trunking Format .....	8
Conventional Format .....	8
<b>SWITCHING POWER ON/OFF .....</b>	<b>8</b>
<b>ADJUSTING THE VOLUME .....</b>	<b>8</b>
<b>SELECTING A SYSTEM/ GROUP/ CHANNEL .....</b>	<b>8</b>
<b>TIME-OUT TIMER (TOT) .....</b>	<b>8</b>
<b>HORN ALERT .....</b>	<b>8</b>
<b>TRUNKING FORMAT .....</b>	<b>9</b>
<b>TRUNKED OPERATION .....</b>	<b>9</b>
Placing a Dispatch Call .....	9
Receiving a Dispatch Call .....	9
Placing a Telephone Call .....	9
Receiving a Telephone Call .....	10
<b>CONVENTIONAL OPERATION .....</b>	<b>10</b>
Transmitting .....	10
Receiving .....	10
<b>SYSTEM SCAN .....</b>	<b>10</b>
Scanning Trunked Systems .....	11
Scanning Conventional Systems .....	11
Scan Lockout .....	11
Scan Revert .....	11
<b>GROUP SCAN .....</b>	<b>11</b>
<b>CONVENTIONAL FORMAT .....</b>	<b>12</b>
<b>CONVENTIONAL OPERATION .....</b>	<b>12</b>
Transmitting .....	12
Receiving .....	12
<b>SCAN .....</b>	<b>13</b>
Priority Scan .....	13
<b>2-TONE SIGNALLING .....</b>	<b>13</b>
<b>DTMF (DUAL TONE MULTI FREQUENCY) CALLS .....</b>	<b>14</b>
<b>MAKING A DTMF CALL .....</b>	<b>14</b>
<b>DTMF SIGNALLING .....</b>	<b>15</b>
<b>DBD (DEAD BEAT DISABLE) .....</b>	<b>15</b>
<b>AUDIBLE USER FEEDBACK TONES .....</b>	<b>16</b>

## UNPACKING AND CHECKING EQUIPMENT

*Note: The following unpacking instructions are for use by your **KENWOOD** dealer, an authorized **KENWOOD** service facility, or the factory.*

Carefully unpack the transceiver. We recommend that you identify the items listed in the following table before discarding the packing material. If any items are missing or have been damaged during shipment, file a claim with the carrier immediately.

### SUPPLIED ACCESSORIES

Item	Part Number	Quantity
Microphone and microphone cable	T91-0597-XX	1
Microphone hanger with self-tapping screws	J19-1584-XX	1 set
DC power cable	E30-3339-XX	1
Mounting bracket	J29-0627-XX	1
Speaker jack cap	B09-0235-XX	1
Screw set: <ul style="list-style-type: none"> <li>• Self-tapping screw (4 pieces)</li> <li>• Hex-headed screw with washer (4 pieces)</li> <li>• Spring washer (4 pieces)</li> <li>• Flat washer (4 pieces)</li> </ul>	N99-0395-XX	1
Warranty card (U.S.A./ Canada only)	—	1
Instruction manual	B62-0994-XX	1

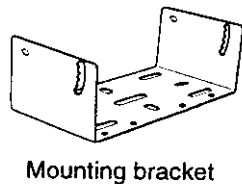
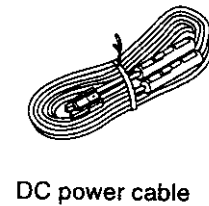
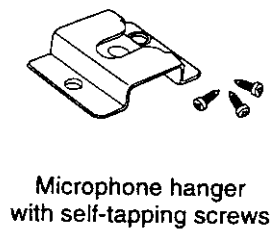
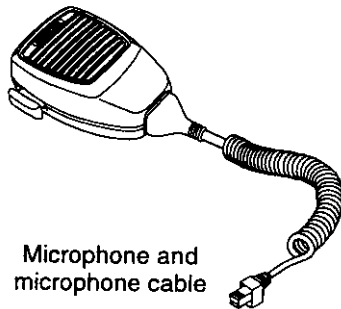

## PREPARATION

**WARNING!** VARIOUS ELECTRONIC EQUIPMENT IN YOUR VEHICLE MAY MALFUNCTION IF THEY ARE NOT PROPERLY PROTECTED FROM THE RADIO FREQUENCY ENERGY WHICH IS PRESENT WHILE TRANSMITTING. ELECTRONIC FUEL INJECTION, ANTI-SKID BRAKING, AND CRUISE CONTROL SYSTEMS ARE TYPICAL EXAMPLES OF EQUIPMENT THAT MAY MALFUNCTION. IF YOUR VEHICLE CONTAINS SUCH EQUIPMENT, CONSULT THE DEALER FOR THE MAKE OF VEHICLE AND ENLIST HIS AID IN DETERMINING IF THEY WILL PERFORM NORMALLY WHILE TRANSMITTING.

**Note:** The following preparation instructions are for use by your **KENWOOD** dealer, an authorized **KENWOOD** service facility, or the factory.

### TOOLS REQUIRED

**Note:** Before installing the transceiver, always check how far the mounting screws will extend below the mounting surface. When drilling mounting holes, be careful not to damage vehicle wiring or parts.

The following tools are required for installing the transceiver:

- 6 mm (1/4 inch) or larger electric drill
- Drill bits (sizes listed below) and circle cutters

Drill Bit Size	Purpose
4.2 mm (5/32 inch)	5 x 16 mm self-tapping screws
3.2 mm (1/8 inch)	4 x 16 mm self-tapping screws

### POWER CABLE CONNECTION

**CAUTION:** THE TRANSCEIVER OPERATES IN 12 V NEGATIVE GROUND SYSTEMS ONLY! CHECK THE BATTERY POLARITY AND VOLTAGE OF THE VEHICLE BEFORE INSTALLING THE TRANSCEIVER.

- 1 Check for an existing hole, conveniently located in the firewall, where the power cable can be passed through.
  - If no hole exists, use a circle cutter to drill the firewall, then install a rubber grommet.
- 2 Run the two power cable leads through the firewall and into the engine compartment, from the passenger compartment.
- 3 Connect the red lead to the positive (+) battery terminal and the black lead to the negative (-) battery terminal.
  - Locate the fuse as close to the battery as possible.
- 4 Recoil and secure the surplus cable with the provided retaining band.
  - Be sure to leave enough slack in the cables so the transceiver can be removed for servicing while keeping the power applied.

## INSTALLING THE TRANSCEIVER

**WARNING!** FOR PASSENGER SAFETY, INSTALL THE TRANSCEIVER SECURELY, USING THE SUPPLIED MOUNTING BRACKET, SO THE TRANSCEIVER WILL NOT BREAK LOOSE IN THE EVENT OF A COLLISION.

- 1 Mark the position of the holes in the dash by using the mounting bracket as a template. Drill the holes, then attach the mounting bracket using the supplied 5 x 16 mm screws.
  - Be sure to mount the transceiver in a location where the controls are within easy reach of the user, and where there is sufficient space at the rear of the transceiver for cable connections.
- 2 Connect the antenna and the supplied power cable to the transceiver.
- 3 Slide the transceiver into the mounting bracket and secure it using the supplied hex-headed screws.
- 4 Mount the microphone hanger, using the supplied 4 x 16 mm screws, in a location where it will be within easy reach of the user.
  - The microphone and microphone cable should be mounted in a place where they will not interfere with the safe operation of the vehicle.
- 5 Connect one plug of the microphone cable to the jack on the base of the microphone, and the other plug to the microphone jack on the front panel of the transceiver. Place the microphone on the hanger.

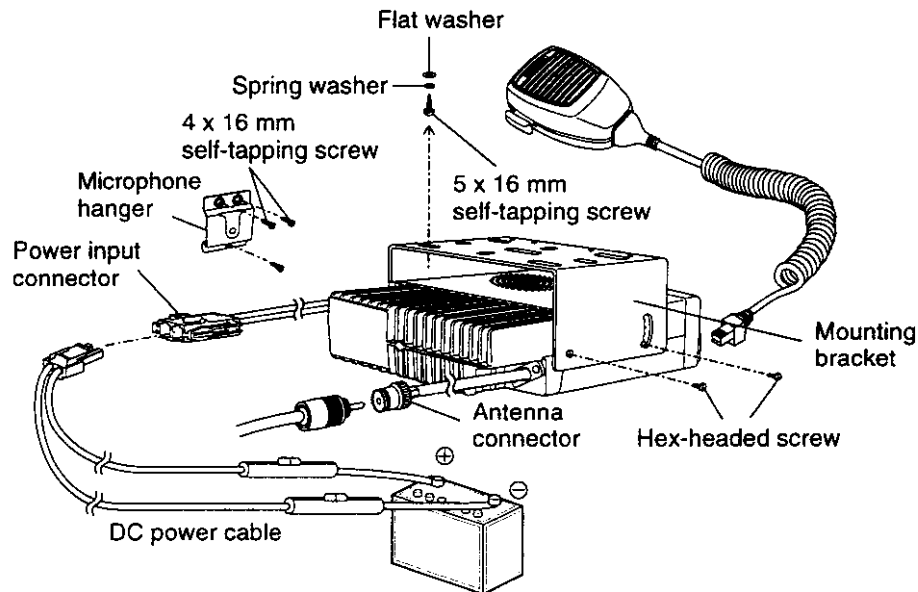

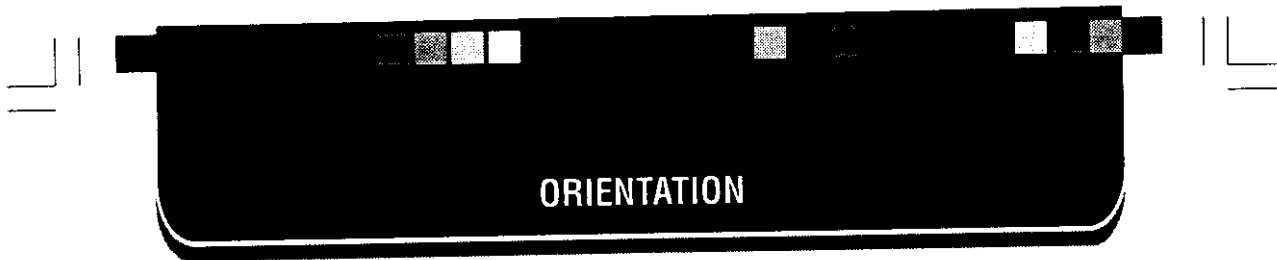

## FRONT PANEL AND MICROPHONE

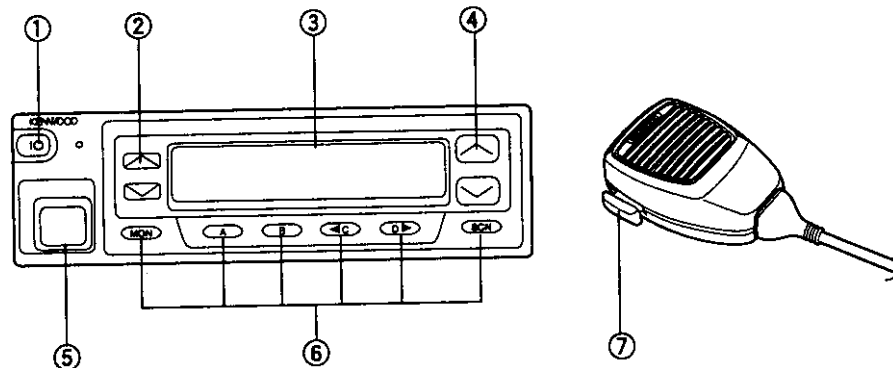

- ① **IO (Power) switch**  
Press to switch the transceiver ON (or OFF).
- ② **^ / v keys**  
Press these keys to activate their programmable auxiliary functions {page 6}.
- ③ **Display**  
See page 5 for more information.
- ④ **^ / v keys**  
Press these keys to activate their programmable auxiliary functions {page 6}.
- ⑤ **Microphone connector**  
Insert the microphone plug into this connector.
- ⑥ **MON, A, B, C, D, and SCN keys**  
Press these keys to activate their programmable auxiliary functions {page 6}.
- ⑦ **PTT switch**  
To transmit, press and hold this switch, then speak into the microphone. Release to receive.



## DISPLAY

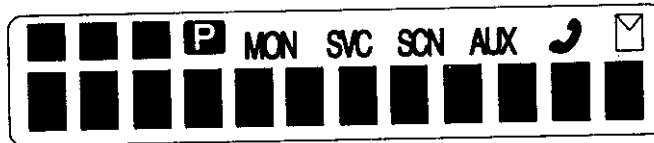

Indicator	Description
■ ■ ■	Displays the system, group, and channel numbers. Also displays various functions which have been programmed by your dealer.
P	Appears when the selected channel is programmed as priority.
MON	Appears when the key programmed as <b>Monitor</b> is pressed.
SVC	This icon is not used on this transceiver.
SCN	Appears when you are using Scan mode.
ALX	Appears when the auxiliary function is activated.
☎	In Trunking Format, appears when the selected group is programmed as telephone IDs. In Conventional Format, appears when you are using the Operator Selectable Tone function.
☑	This icon is not used on this transceiver.
■■■■■■■■■■	Displays the system, group, and channel numbers. Your dealer can program the system, group, and channel names with up to 10 characters, in place of numbers. The left most display is used as a delete indicator (▶) in Trunking Format and an add indicator (▼) in Conventional Format. The right most display is used for the Selective Call (* ) or Scrambler ( _ ) function. The delete/ add indicators show the systems/ channels that are locked/ not locked out of the scanning sequence. Selective Call and Scrambler are optional functions that can be programmed by your dealer.

## REAR PANEL

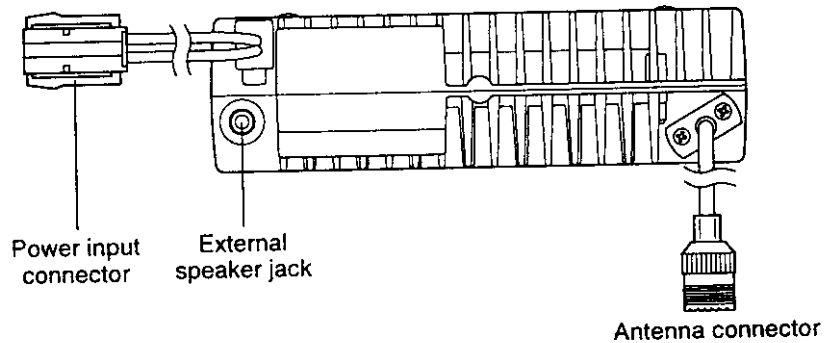

## PROGRAMMABLE AUXILIARY FUNCTIONS

Keys ②, ④, and ⑥ (page 4) can be programmed with the auxiliary functions listed in the following table. The keys can only be programmed with functions, depending on whether you are using Conventional Format or Trunking Format. Please contact your dealer for further details on these functions.

*Note: If "Function" is programmed onto one of the above mentioned keys, the DTMF keypad (keypad models only) can also be used for additional programmable keys.*

Function	Conventional Format	Trunking Format
Auto Tel	No	Yes
AUX A	Yes	Yes
AUX B <sup>1</sup>	Yes	Yes
Channel Down	Yes	No
Channel Up	Yes	No
Connect ID	Yes	Yes
Disconnect ID	Yes	Yes
Display Character	Yes	Yes
Emergency <sup>2</sup>	Yes	Yes
Function	Yes	Yes
Group Down	Yes	Yes
Group Up	Yes	Yes
Home Channel	Yes	No
Home Group	No	Yes
Horn Alert	Yes	Yes
Key Lock	Yes	Yes
Memory (RCL/STO)	Yes	Yes
Memory (RCL)	Yes	Yes
Memory (STO)	Yes	Yes
Monitor A (Monitor Unmute (Momentary))	Yes	Yes
Monitor B (Monitor Unmute (Toggle))	Yes	Yes
Monitor C (Carrier Squelch (Momentary))	Yes	Yes
Monitor D (Carrier Squelch (Toggle))	Yes	Yes
Operator Sel Tone	Yes	No
Public Address	Yes	Yes
Redial	Yes	Yes

Function	Conventional Format	Trunking Format
Scan	Yes	Yes
Scan Del/Add	Yes	Yes
Scan Temporary Delete	No	Yes
System Down	No	Yes
System Up	No	Yes
Scrambler <sup>3</sup>	Yes	Yes
Talk Around	Yes	No
Tel Disconnect	No	Yes
Volume Down	Yes	Yes
Volume Up	Yes	Yes

<sup>1</sup> This function can be selected only when the Scrambler/ ANI board has not been installed.

<sup>2</sup> This function can be used only with a foot switch.

<sup>3</sup> This function can be selected only when the Scrambler board has been installed.

## BASIC OPERATIONS

### OPERATION OVERVIEW

Your dealer can program your transceiver for Trunking or Conventional Format.

#### ■ Trunking Format

This format can handle up to 600 channels in conventional mode, and 32 systems with up to 250 groups in each system in trunking mode. Systems, groups, channels, and their functions are programmed by your dealer.

#### ■ Conventional Format

This format can handle up to 250 groups with 250 channels in each group. The transceiver can be used only in conventional mode. Groups, channels, and their functions are programmed by your dealer.

### SWITCHING POWER ON/OFF

Press the **IO** switch to switch the transceiver ON (or OFF).

### ADJUSTING THE VOLUME

Press the key programmed as **Volume Up** or **Volume Down** to adjust the volume. **Volume Up** increases the volume and **Volume Down** decreases it.

### SELECTING A SYSTEM/ GROUP/ CHANNEL

Select the desired system and group (Trunking Format) using the keys programmed with the **System** and **Group** functions.

Select the desired group and channel (Conventional Format) using the keys programmed with the **Group** and **Channel** functions.

### TIME-OUT TIMER (TOT)

The purpose of the Time-out Timer is to prevent any caller from using a channel for an extended period of time.

If you continuously transmit for a period of time that exceeds the programmed time, the transceiver will stop transmitting and an alert tone will sound. To stop the tone, release the **PTT** switch.

Your dealer can program the TOT time in the range of 15 seconds to 10 minutes.

### HORN ALERT

If Horn Alert has been installed by your dealer, your vehicle horn, or some other type of external alert, will sound when certain calls are received. This is a useful function when you are away from your vehicle.

## TRUNKING FORMAT

### TRUNKED OPERATION

#### ■ Placing a Dispatch Call

- 1 Select the desired system and group using the **System** and **Group** keys.
- 2 Press the **PTT** switch.
- 3 If a tone does not sound, communication is possible; start speaking into the microphone. Release the **PTT** switch to receive.
  - For best sound quality at the receiving station, hold the microphone approximately 1.5 inches (3 - 4 cm) from your mouth.
- 4 When your conversation is finished, return the microphone to its hanger.

#### ■ Receiving a Dispatch Call

- 1 Select the desired system and group using the **System** and **Group** keys. (If the Scan function has been programmed, you can switch it ON or OFF as desired.)
- 2 When you hear the dispatcher's voice, readjust the volume as necessary.

#### ■ Placing a Telephone Call

*Note: You can only make a telephone call if the telephone service is available and you have an optional keypad microphone. Refer to "MAKING A DTMF CALL" on page 14. Consult your dealer for further details.*

- 1 Select the desired system and group using the **System** and **Group** keys.
- 2 Press and hold the **PTT** switch for approximately 1 second to ensure a connection.
  - Confirm that there is a dial tone after releasing the **PTT** switch.
- 3 Dial using the microphone keypad.
  - After dialing, wait for a response from the called party.
- 4 When the called party responds, press the **PTT** switch and speak into the microphone. Release the **PTT** switch to receive.
  - Only one person can speak at a time.
- 5 To end the call, press the # key or the key programmed as **Tel Disconnect**.

## ■ Receiving a Telephone Call

- 1 Select the desired system and group using the **System** and **Group** keys. (If the Scan function has been programmed, you can switch it ON or OFF as desired.)
  - A ringing tone will sound when a call is received.
- 2 Press and hold the **PTT** switch to speak, and release it to listen.
  - Only one person can speak at a time.
- 3 To end the call, press the # key or the key programmed as **Tel Disconnect**.

## CONVENTIONAL OPERATION

### ■ Transmitting

*Note: Before transmitting, monitor the channel to make sure it is not already in use. If the selected group is programmed with QT (Quiet Talk) or DQT (Digital Quiet Talk), remove the microphone from the hook to disable QT or DQT, then listen to the channel to make sure nobody is talking on it. If the selected group is not programmed with QT or DQT, simply listen to the channel to make sure nobody is talking on it. In this case, you need not remove the microphone from the hook.*

- 1 Select the desired system and group using the **System** and **Group** keys.
  - If the channel is busy, wait until it becomes free.
- 2 Press the **PTT** switch and speak into the microphone. Release the **PTT** switch to receive.
  - For best sound quality at the receiving station, hold the microphone approximately 1.5 inches (3 - 4 cm) from your mouth.
- 3 When your conversation is finished, return the microphone to its hanger.

### ■ Receiving

- 1 Select the desired system and group using the **System** and **Group** keys. (If the Scan function has been programmed, you can switch it ON or OFF as desired.)
- 2 When you hear the dispatcher's voice, readjust the volume as necessary.

## SYSTEM SCAN

If the Scan function is programmed, systems can be scanned by pressing the key programmed as **Scan**. When the **Scan** key is pressed, the SCN indicator and "-SCAN-" or the revert system/ group number, appear on the display and scanning starts. The systems not locked out of the scanning sequence are scanned.

When a call is received, scanning stops and the system and group digits appear. Press the **PTT** switch and speak into the microphone to respond to the call. The transceiver will continue scanning after an adjustable time delay if the **PTT** switch is released and no further signal is received.



### ■ Scanning Trunked Systems

When scanning trunked systems, the revert groups and the groups not locked out of the scanning sequence are scanned. See "GROUP SCAN", below.

### ■ Scanning Conventional Systems

When scanning conventional systems, the revert groups and the groups not locked out of the scanning sequence are scanned. See "GROUP SCAN", below.

### ■ Scan Lockout

If a programmable auxiliary key is programmed with **Scan DEL/ADD**, each system can be locked out of the scan sequence manually. The delete indicator (▶) will appear in the display when the selected system is locked out.

### ■ Scan Revert

You can select revert systems and groups using the **System** and **Group** keys.

Three types of Scan Reverts which can be programmed by your dealer are available:

- **Last Called Revert:** The last system/ group received is assigned as the new revert system and group.
- **Last Used Revert:** The last system/ group responded to is assigned as the new revert system and group.
- **Selected:** The last system/ group selected is assigned as the new revert system and group.

## GROUP SCAN

Group Scan is available for both trunked and conventional systems. This feature is useful when more than one group is programmed in a system. Group Scan is set by your dealer on request. It scans the revert groups as well as groups that are allowed to be scanned.

When a call is received, the group indicator shows the group number, and that group becomes the revert group. Simply press the **PTT** switch to respond to the call.

You can also perform Group Scan while using a priority channel. Please contact your dealer for information concerning Priority Scan.

## CONVENTIONAL FORMAT

### CONVENTIONAL OPERATION

#### ■ Transmitting

*Note: Before transmitting, monitor the channel to make sure it is not already in use. If the selected channel is programmed with QT (Quiet Talk) or DQT (Digital Quiet Talk), remove the microphone from the hook to disable QT or DQT, then listen to the channel to make sure nobody is talking on it. If the selected channel is not programmed with QT or DQT, simply listen to the channel to make sure nobody is talking on it; in this case, you need not remove the microphone from the hook.*

- 1 Select the desired group and channel using the **Group** and **Channel** keys.
  - If the channel is busy, wait until it becomes free.
- 2 Press the **PTT** switch and speak into the microphone. Release the **PTT** switch to receive.
  - For best sound quality at the receiving station, hold the microphone approximately 1.5 inches (3 - 4 cm) from your mouth.
- 3 When your conversation is finished, return the microphone to its hanger.

#### ■ Receiving

- 1 Select the desired group and channel using the **Group** and **Channel** keys. (If the Scan function has been programmed, you can switch it ON or OFF as desired.)
- 2 When you hear the dispatcher's voice, readjust the volume as necessary.



## SCAN

If the Scan function is programmed, groups or channels can be scanned by pressing the key programmed as **Scan**. Scan can be used as either Single Scan or Multi Scan. Single Scan monitors only the channels of a single group. Multi Scan monitors all channels of every group. When the **Scan** key is pressed, the SCN indicator and "-SCAN-" or the revert group/ channel number, appear on the display and scanning starts.

When a call is received, scanning stops and the group and channel digits appear. Press the **PTT** switch and speak into the microphone to respond to the call. The transceiver will continue scanning after an adjustable time delay, if the **PTT** switch is released, and no further signal is received.

When the displayed group is not locked out of the scanning sequence, the add indicator (▼) will appear on the display.

### ■ Priority Scan

The priority channel must be programmed in order for Priority Scan to function.

The transceiver will automatically change to the priority channel when a signal is received on it, even if a signal is being received on a normal channel.

The  indicator appears when the displayed channel is the priority channel.

## 2-TONE SIGNALLING

2-Tone Signalling is either activated or deactivated by your dealer.

2-Tone Signalling only opens the squelch when the transceiver receives two tones corresponding to those set up in the transceiver. When the squelch opens, you will be able to hear the caller without any further action.

After a correct 2-Tone signal is received and the squelch opens, pressing the key programmed as **Monitor** will cancel the connection.

If your dealer programmed Transpond for 2-Tone Signalling, your transceiver will automatically send an acknowledgment signal to the station that called you with a correct 2-Tone signal. Transpond does not function when you are called as a Group call.

If your dealer programmed Tone Alert for 2-Tone Signalling, your transceiver will emit a beep when the correct 2-Tone signal is received.

*Note: This transceiver is only capable of decoding 2-Tone Signals. It cannot encode a 2-Tone Signal.*

## DTMF (DUAL TONE MULTI FREQUENCY) CALLS

### MAKING A DTMF CALL

**Note:** To make a DTMF call, you must have an optional microphone with a DTMF keypad. Ask your dealer for more information.

There are two methods of making a DTMF call:

- Manual dialing
- Store and sending

To make a call by dialing manually:

- 1 Press and hold the **PTT** switch.
- 2 Enter the desired digits using the microphone keypad.
  - The corresponding DTMF tones sound each time you press a key.
  - If you release the **PTT** switch, transmit mode will end even if the complete number has not been sent.
  - If your dealer has activated the Keypad Auto PTT function, you need not hold down the **PTT** switch while pressing the keys on the keypad. The DTMF code will be sent automatically when you press a key.

To make a call by storing and sending:

- 1 Enter the desired digits using the microphone keypad.
  - The digits appear on the display as you enter them.
- 2 After entering the complete number, press the **PTT** switch.
  - If you are using the transceiver in a Conventional mode and Format, the DTMF code is transmitted after pressing the **PTT** switch.
  - If you are using the transceiver in a Trunking system, the DTMF code is transmitted after a connection is established. Releasing the **PTT** switch before a connection is established will stop the transmission from occurring.
  - If you are using the transceiver in a RIC (Repeater Inter-Connect) Trunking system, the DTMF code is transmitted after a connection with the telephone system is established. If you press the key programmed as **Auto Tel** instead of the **PTT** switch, the call will automatically connect to the repeater, and the DTMF code will be transmitted.

**Note:**

- ◆ *Store and send must first be activated by your dealer in order for it to function.*
- ◆ *You can only store up to 16 digits before sending. Entering more than 16 digits will cause an error tone to sound.*
- ◆ *In store and sending mode, if you switch the power OFF before sending the number, the number will be cleared from memory.*



## DTMF SIGNALLING

Your dealer can program a group or channel with DTMF signalling. When you receive a call with a code that matches yours, the signalling indicator (:\*) will flash and a tone will sound. Squelch opens and you will hear the call.

Squelch will close when you receive a call with a code that matches your signalling reset code.

When making a call on a group or channel programmed with a DTMF signalling code, the signalling indicator will light and the squelch will open.

If your dealer programmed Transpond for DTMF signalling, your transceiver will automatically send an acknowledgment signal to the station that called you with the correct DTMF code.

## DBD (DEAD BEAT DISABLE)

Depending on how your dealer programs your transceiver, when you receive a call containing a DBD code, either transmit mode or receive and transmit modes will be disabled. When a DBD code is received, a tone will sound.

DBD is cancelled when you receive a call with a DBD cancel code.

## AUDIBLE USER FEEDBACK TONES

The transceiver emits various tones to indicate the transceiver's operating status. Please contact your dealer for further information on these tones.

Tone	Conventional Format	Trunking Format
Alert	Yes	Yes
Busy	Yes	Yes
DBD On	Yes	Yes
DBD Off	No	Yes
Delay	No	Yes
Deny	No	Yes
Free System Ring Back Mode/ System Search Mode	Yes	Yes
Group Call	Yes	Yes
Individual Call	No	Yes
Intercept	Yes	Yes
Key Input Error	Yes	Yes
Key Press [A]	Yes	Yes
Key Press [B]	Yes	Yes
Key Press [C]	Yes	Yes
Password Agreement	Yes	Yes
Power ON	Yes	No
Pre Alert	No	Yes
Proceed	Yes	Yes
PTT Release	No	Yes
Queue	No	Yes
Ringling	Yes	Yes
Roll Over	No	Yes
System Search	No	Yes
System Search End	Yes	Yes
Transpond		