

KENWOOD

INSTRUCTION MANUAL



VHF FM TRANSCEIVER

TK-760G

UHF FM TRANSCEIVER

TK-860G

KENWOOD CORPORATION

© B62-1258-00 (K, M)
09 08 07 06 05 04 03 02 01 00

THANK YOU!

We are grateful you chose **KENWOOD** for your personal mobile applications. We believe this easy-to-use transceiver will provide dependable communications to keep personnel operating at peak efficiency.

KENWOOD transceivers incorporate the latest in advanced technology. As a result, we feel strongly that you will be pleased with the quality and features of this product.

MODELS COVERED BY THIS MANUAL

The models listed below are covered by this manual:

- **TK-760G:** VHF FM Transceiver
- **TK-860G:** UHF FM Transceiver

One or more of the following statements may be applicable:

FCC WARNING

This equipment generates or uses radio frequency energy. Changes or modifications to this equipment may cause harmful interference unless the modifications are expressly approved in the instruction manual. The user could lose the authority to operate this equipment if an unauthorized change or modification is made.

INFORMATION TO THE DIGITAL DEVICE USER REQUIRED BY THE FCC

This equipment has been tested and found to comply with the limits for a Class B digital device, pursuant to Part 15 of the FCC Rules. These limits are designed to provide reasonable protection against harmful interference in a residential installation.

This equipment generates, uses and can generate radio frequency energy and, if not installed and used in accordance with the instructions, may cause harmful interference to radio communications. However, there is no guarantee that the interference will not occur in a particular installation. If this equipment does cause harmful interference to radio or television reception, which can be determined by turning the equipment off and on, the user is encouraged to try to correct the interference by one or more of the following measures:

- *Reorient or relocate the receiving antenna.*
- *Increase the separation between the equipment and receiver.*
- *Connect the equipment to an outlet on a circuit different from that to which the receiver is connected.*
- *Consult the dealer for technical assistance.*

NOTICES TO THE USER

- ◆ *GOVERNMENT LAW PROHIBITS THE OPERATION OF UNLICENSED RADIO TRANSMITTERS WITHIN THE TERRITORIES UNDER GOVERNMENT CONTROL.*
- ◆ *ILLEGAL OPERATION IS PUNISHABLE BY FINE OR IMPRISONMENT OR BOTH.*
- ◆ *REFER SERVICE TO QUALIFIED TECHNICIANS ONLY.*

SAFETY: It is important that the operator is aware of, and understands, hazards common to the operation of any transceiver.

WARNING!

- ◆ **EXPLOSIVE ATMOSPHERES (GASES, DUST, FUMES, etc.)**
Turn OFF your transceiver while taking on fuel or while parked in gasoline service stations. Do not carry spare fuel containers in the trunk of your vehicle if your transceiver is mounted in the trunk area.
- ◆ **INJURY FROM RADIO FREQUENCY TRANSMISSIONS**
Do not operate your transceiver when somebody is either touching the antenna or standing within two to three feet of it, to avoid the possibility of radio frequency burns or related physical injury.
- ◆ **DYNAMITE BLASTING CAPS**
Operating the transceiver within 500 feet of dynamite blasting caps may cause them to explode. Turn OFF your transceiver when in an area where blasting is in progress, or where "TURN OFF TWO-WAY RADIO" signs have been posted. If you are transporting blasting caps in your vehicle, make sure they are carried in a closed metal box with a padded interior. Do not transmit while the caps are being placed into or removed from the container.

PRECAUTIONS

Please observe the following precautions to prevent fire, personal injury, and transceiver damage.

- Do not attempt to configure the transceiver while driving; it is too dangerous.
- Do not modify the transceiver for any reason.
- Do not expose the transceiver to long periods of direct sunlight, nor place it near heating appliances.
- Do not place the transceiver in excessively dusty, humid, or wet areas, not on unstable surfaces.
- If an abnormal odor or smoke is detected coming from the transceiver, turn OFF the power immediately. Contact your **KENWOOD** dealer.

CONTENTS

UNPACKING AND CHECKING EQUIPMENT	
SUPPLIED ACCESSORIES	1
PREPARATION	
TOOLS REQUIRED	2
POWER CABLE CONNECTION	2
INSTALLING THE TRANSCEIVER	3
ORIENTATION	
FRONT PANEL AND MICROPHONE	4
DISPLAY	5
REAR PANEL	5
PROGRAMMABLE AUXILIARY FUNCTIONS	6
PROGRAMMABLE FUNCTIONS	6
BASIC OPERATIONS	
RECEIVING	8
Switching Powr ON/OFF	8
Adjusting the Volume	8
Selecting a Channel	8
CALLING	9
Monitoring the channel	9
Busy Channel Lockout	9
Time-Out Timer	9
ADVANCED OPERATIONS	
SCANNING CHANNELS	9
Priority Scan	9
Channel lockoul	9
TALK-AROUNDI	11
2-TONE SIGNALLING	11
Select and encodeing 2-tone signalling	11
HORN ALERT	12
OPERATOR SELECTABLE TONE	12
PUBLIC ADDRESSSS	12
AUX	12
DTMF (DUAL TONE MULTI FREQUENCY) CALLS	
MAKING A DTMF CALL	13
Auto Dialing.....	13
Manual Dialing	13
Store and Send Dialing	13
DTMF SIGNALLING	14
DBD (DEAD BEAT DISABLE)	14

UNPACKING AND CHECKING EQUIPMENT

Note: The following unpacking instructions are for use by your **KENWOOD** dealer, an authorized **KENWOOD** service facility, or the factory.

Carefully unpack the transceiver. We recommend that you identify the items listed in the following table before discarding the packing material. If any items are missing or have been damaged during shipment, file a claim with the carrier immediately.

SUPPLIED ACCESSORIES

Item	Part Number	Quantity
Microphone and microphone cable	T91-0597-XX	1
Microphone hanger with self-tapping screws	J19-1584-XX	1 set
DC power cable	E30-3339-XX	1
Mounting bracket	J29-0627-XX	1
Speaker jack cap	B09-0235-XX	1
Screw set: <ul style="list-style-type: none"> • Self-tapping screw (4 pieces) • Hex-headed screw with washer (4 pieces) • Spring washer (4 pieces) • Flat washer (4 pieces) 	N99-0395-XX	1
Fuse (10A)	F51-0061-XX	2
Warranty card (U.S.A./ Canada only)	—	1
Instruction manual	B62-1257-XX	1

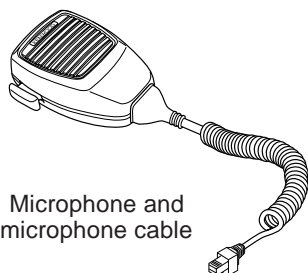

Microphone and microphone cable

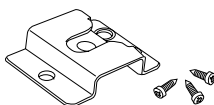

Microphone hanger with self-tapping screws

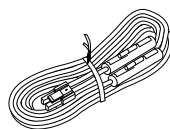

DC power cable

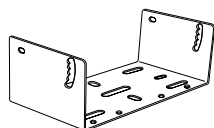

Mounting bracket



Speaker jack cap



Screw set

PREPARATION

WARNING! VARIOUS ELECTRONIC EQUIPMENT IN YOUR VEHICLE MAY MALFUNCTION IF THEY ARE NOT PROPERLY PROTECTED FROM THE RADIO FREQUENCY ENERGY WHICH IS PRESENT WHILE TRANSMITTING. ELECTRONIC FUEL INJECTION, ANTI-SKID BRAKING, AND CRUISE CONTROL SYSTEMS ARE TYPICAL EXAMPLES OF EQUIPMENT THAT MAY MALFUNCTION. IF YOUR VEHICLE CONTAINS SUCH EQUIPMENT, CONSULT THE DEALER FOR THE MAKE OF VEHICLE AND ENLIST HIS AID IN DETERMINING IF THEY WILL PERFORM NORMALLY WHILE TRANSMITTING.

Note: The following preparation instructions are for use by your **KENWOOD** dealer, an authorized **KENWOOD** service facility, or the factory.

TOOLS REQUIRED

Note: Before installing the transceiver, always check how far the mounting screws will extend below the mounting surface. When drilling mounting holes, be careful not to damage vehicle wiring or parts.

The following tools are required for installing the transceiver:

- 6 mm (1/4 inch) or larger electric drill
- Drill bits (sizes listed below) and circle cutters

Drill Bit Size	Purpose
4.2 mm (5/32 inch)	5 x 16 mm self-tapping screws
3.2 mm (1/8 inch)	4 x 16 mm self-tapping screws

POWER CABLE CONNECTION

CAUTION: THE TRANSCEIVER OPERATES IN 12 V NEGATIVE GROUND SYSTEMS ONLY! CHECK THE BATTERY POLARITY AND VOLTAGE OF THE VEHICLE BEFORE INSTALLING THE TRANSCEIVER.

- 1 Check for an existing hole, conveniently located in the firewall, where the power cable can be passed through.
 - If no hole exists, use a circle cutter to drill the firewall, then install a rubber grommet.
- 2 Run the two power cable leads through the firewall and into the engine compartment, from the passenger compartment.
- 3 Connect the red lead to the positive (+) battery terminal and the black lead to the negative (-) battery terminal.
 - Locate the fuse as close to the battery as possible.
- 4 Recoil and secure the surplus cable with the provided retaining band.
 - Be sure to leave enough slack in the cables so the transceiver can be removed for servicing while keeping the power applied.

INSTALLING THE TRANSCEIVER

WARNING! FOR PASSENGER SAFETY, INSTALL THE TRANSCEIVER SECURELY, USING THE SUPPLIED MOUNTING BRACKET, SO THE TRANSCEIVER WILL NOT BREAK LOOSE IN THE EVENT OF A COLLISION.

- 1 Mark the position of the holes in the dash by using the mounting bracket as a template. Drill the holes, then attach the mounting bracket using the supplied 5 x 16 mm screws.
 - Be sure to mount the transceiver in a location where the controls are within easy reach of the user, and where there is sufficient space at the rear of the transceiver for cable connections.
- 2 Connect the antenna and the supplied power cable to the transceiver.
- 3 Slide the transceiver into the mounting bracket and secure it using the supplied hex-headed screws.
- 4 Mount the microphone hanger, using the supplied 4 x 16 mm screws, in a location where it will be within easy reach of the user.
 - The microphone and microphone cable should be mounted in a place where they will not interfere with the safe operation of the vehicle.
- 5 Connect one plug of the microphone cable to the jack on the base of the microphone, and the other plug to the microphone jack on the front panel of the transceiver. Place the microphone on the hanger.

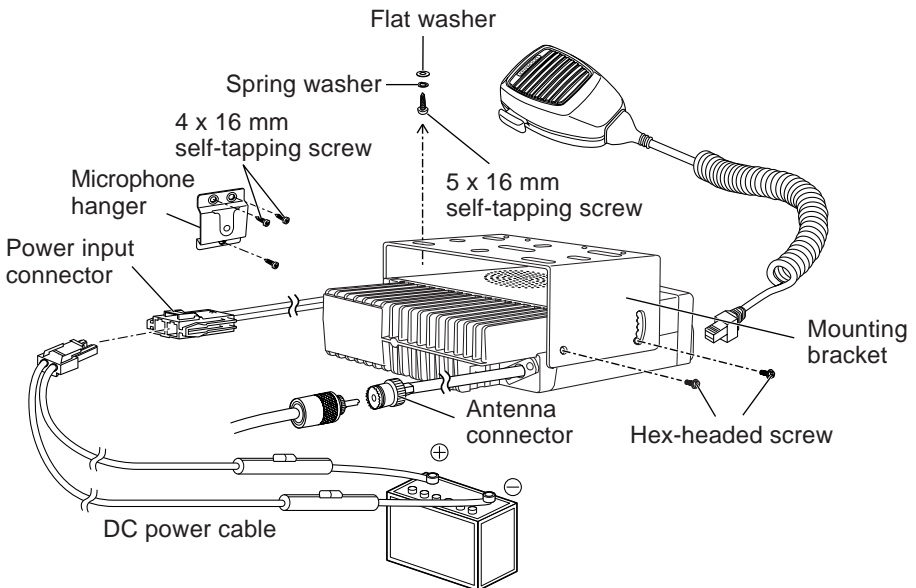

ORIENTATION

FRONT PANEL AND MICROPHONE

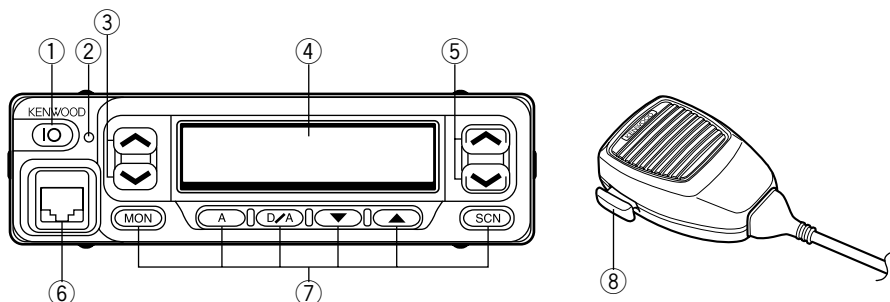

- ① **IO (Power) switch**
Press to switch the transceiver ON (or OFF).
- ② **Status LED**
Red LED indicates that the transceiver is transmitting. Green LED indicates that the transceiver is receiving the signal.
- ③ **^ / v keys**
Press these keys to activate their programmable auxiliary functions {page 7}. Default setting is **VOLUME Up/Down** keys.
- ④ **Display**
See page 5 for more information.
- ⑤ **^ / v keys**
Press these keys to activate their programmable auxiliary functions {page 7}. Default setting is **Channel Up/Down** keys.
- ⑥ **Microphone connector**
Insert the microphone plug into this connector.
- ⑦ **MON, A, D/A, v, ^, and SCN keys**
Press these keys to activate their programmable auxiliary functions {page 7}.
- ⑧ **PTT switch**
To transmit, press and hold this switch, then speak into the microphone. Release to receive.

DISPLAY

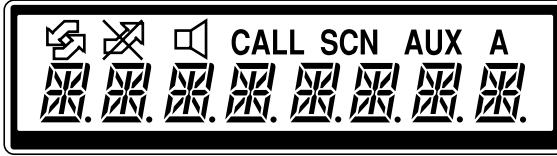

Indicator	Description
	This icon is not used on this transceiver.
	Appears when signals are present on the currently selected channel.
	Appears when the Monitor function is activated.
CALL	Appears when you have called with preprogrammed 2-tone signalling code or DTMF selective call from another party.
SCN	Appears while the transceiver is scanning.
AUX	Appears while AUX port is activated by the user.
A	Appears when the displayed channel is in "Scan list".
	A main display. It displays the channel numbers, group numbers and various status. Your dealer can program the channel names with up to 10 characters, in place of numbers.

REAR PANEL

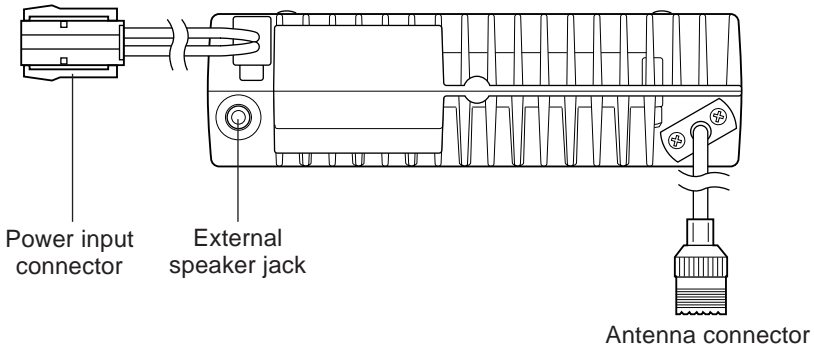

PROGRAMMABLE AUXILIARY FUNCTIONS KEYS

The following keys can be programmed with the auxiliary functions listed in the table on next page.

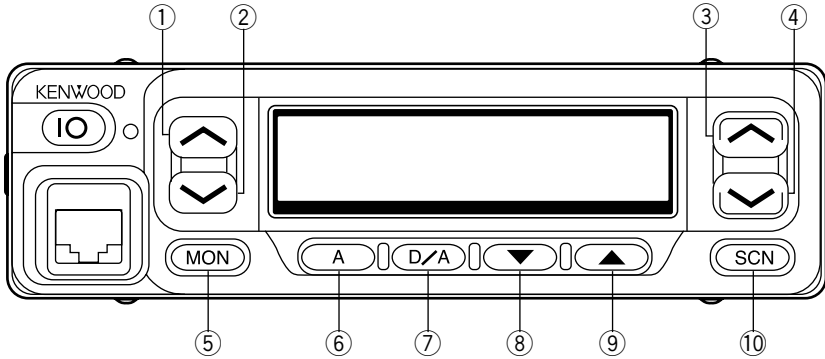

Key Number	Your radio setting	Factory default setting
①		Volume Up
②		Volume Down
③		Channel Up
④		Channel Down
⑤		Monitor A
⑥		---
⑦		---
⑧		---
⑨		---
⑩		---

Note:

- ◆ For your reference, please fill out the form above with the programmed function by your dealer.
- ◆ A list of the programmable functions is available on the next page.

PROGRAMMABLE FUNCTIONS

Short name	Description
AUX	Activate AUX port
Channel Down	Decrease the channel number
Channel Up	Increase the channel number
Display Character	Toggle between channel number display, Group display and alpha-numeric channel name display
Emergency ¹	Activate the emergency mode
Group Down	Decrease group number
Group Up	Increase group number
Home Channel	Return to a preset home channel
Horn Alert	Activate Horn Alert function
Key Lock	Lock all keys except a power key
Monitor A (Monitor Unmute (Momentary))	Monitor the channel while you push this key
Monitor B (Monitor Unmute (Toggle))	Toggle monitor function on and off
Monitor C (Carrier Squelch (Momentary))	Disable QT/DQT/2-tone signalling and open the squelch with the incoming carrier only.
Monitor D (Carrier Squelch (Toggle))	Same as above. Toggles the function on and off
No function	No function
Operator Seletable Tone (K-type only)	Let a user select a tone set from 16 preprogrammed QT/DQT tone pairs
Public Address	Activate Public Address function
Redial	Redial the last number
Scan	Scan the channels as programmed by your dealer
Scan Del/Add	Delete or add the channel from/to the scanning channel list
Talk Around	Force to transmit on the receive frequency
Volume Down	Decrease the volume
Volume Up	Increase the volume
2-Tone Encode Select	Let a user select 1 of 10 preprogrammed 2-tone pairs.

¹ This function can be used only with a foot switch.

BASIC OPERATIONS

RECEIVING

Your dealer may have programmed QT or DQT signalling for the channel that you select. If the channel has been programmed in this way, you will hear transmissions from your group only. Otherwise, you will hear all the transmissions made any stations using the same channel.

■ Switching Power ON/OFF

Press the **IO** switch to switch the transceiver ON (or OFF).

■ Adjusting the Volume

Press the key programmed as **Volume Up** or **Volume Down** to adjust the volume. **Volume Up** increases the volume and **Volume Down** decreases it.

■ Selecting a Channel

Select the desired channel system using the keys programmed with the **Channel Up** and **Down** keys.

***Note:** TK-760G/ TK-860G features 128-channel capacity. In order to manage 128 channels easily, one or more programmed channels can be bundled together as a group.*

*Your dealer may have also programmed **Group Up** and **Down** keys. In this case, please select the desired group and channel number. Please consult your dealer for the details.*

CALLING

■ Monitoring the channel

Press **MON** key (or a key programmed as Monitor) to monitor the channel for a few seconds to confirm that channel is not being used.

After the confirmation, hold the microphone about 3 to 4 cm (1 1/2 inches) from your mouth, press microphone **PTT** , and speak in your normal speaking voice.

Release **PTT** and listen to a response.

■ Busy Channel Lockout

Activated or deactivated by your dealer, this function prevents you from interfering with other stations that may be using a channel. Pressing microphone **PTT** while the selected channel is in use causes your transceiver to generate an audible warning tone. Your transceiver is inhibited in this situation so it will not transmit. Release microphone **PTT** to cancel the alarm and restore the receive mode.

■ Time-Out Timer

The purpose of the time-out timer is to automatically interrupt continuous transmissions after a specified time elapses. Holding down microphone **PTT** for longer than the programmed time causes the transceiver to stop transmitting and generate a warning tone. Releasing microphone **PTT** cancels the warning tone.

ADVANCED OPERATIONS

SCANNING CHANNELS

If the Scan function is enabled, groups or channels can be scanned by pressing the key programmed as Scan. A Scan key can be programmed as either Single Scan or Multi Scan by your dealer.

Single Scan monitors only the channels of a single group. Multi Scan monitors all channels of every group. When the Scan key is pressed, the **SCN** indicator and "SCAN" appear on the display and the scanning starts.

When a call is received on one of scanning channels, scanning stops and the channel information appears on the display. Press **PTT** switch and speak into the microphone to respond to the call. The transceiver will continue scanning after an adjustable time delay, if **PTT** switch is released, and no further signal is received.

■ Priority Scan

Either Fixed priority scan or Selectable priority scan may be programmed by your dealer.

- **Fixed Priority Scan:** The pre-programmed channel is monitored in a certain interval while scanning. When the signal is being received on this priority channel while scanning, you will be transferred to this priority channel.
- **Selectable Priority Scan:** After you select the priority channel using **Channel Up/Down** or **Group Up/Down** keys, press a Scan key, programmed by your dealer. The scanning starts and the selected priority channel is monitored in a certain interval while scanning. When the signal is being received on the selected priority channel while scanning, you will be transferred to this priority channel.

■ Channel lockout

If the channel lockout is enabled by your dealer, you can select channels to add or delete from the scanning channel list. When the displayed channel is not locked out from the scanning, the add indicator **A** (Add) will appear on the display.

1. Using **Channel Up** and **Down** key to select the channel that you wish to add or delete from the scanning list.
2. Press a **Delete/Add** key, programmed by your dealer to add or delete the channel to/from the scanning channel list. If the channel is in the scanning list, **A** (Add) indicator will be lit on the upper right side of the display. **A** (Add) indicator is disappeared from the display, the channel is no longer in the scanning channel list.

TALK-AROUND

Occasionally, a power failure or other cause at the repeater may result in an interruption of service. Your dealer may have provided the Talk-around function for use in such cases. This function allows communication directly with other transceivers without using a repeater. However, even Talk-around may not allow you to contact a station if the distance is too far or there are geographic obstacles in the way.

To enable Talk-around function, press a key, programmed as Talk-around.

"TA" or "T." (depending on the configuration) will be displayed at the left side of LCD display.

Note: When you are in Talk-around mode, all the signalling data, such as QT, DQT, 2-tones are still enabled.

2-TONE SIGNALLING

2-tone signalling is either enabled or disabled by your dealer. 2-tone opens the squelch only when the transceiver receives the preset two sequential tones that have different frequencies.

When the correct tones are received that were programmed by your dealer, the squelch opens, and the caller's voice is monitored.

■ Select and encoding 2-tone signalling

If "2-tone encode select" is programmed by your dealer, you can select 1 of 10 preset 2-tone codes. Then you can send the desired 2-tone to another party.

- 1 Press a key, programmed as 2-tone encode select .
- 2 Select the desired a tone set, using **Channel Up** and **Down** key.
- 3 Press 2-tone encode select key again to set.
- 4 Press **PTT** to send the tone to another party.

HORN ALERT

When a call is received that has correct DTMF codes or 2-tone signalling, Horn Alert causes the vehicle horn or some other external alert to sound. This function notifies you of a received call when you are out of the vehicle.

- 1 To activate the Horn Alert, press the function key programmed as Horn Alert.
- 2 To disable the Horn Alert, press a Horn Alert function key again to return to the normal operation.

OPERATOR SELECTABLE TONE

If this function is enabled by your dealer, you can change the default QT and DQT tone frequencies. You can select 1 of 16 decode/ encode pairs, that is preset by your dealer.

- 1 Use **Channel Up** and **Down** key to select the desired channel
- 2 Press a key, programmed as Operator Selectable Tone.
- 3 Use **Channel Up** and **Down** key to select a desired tone pair.
- 4 Press a key in step 2 again to return to the normal display.

PUBLIC ADDRESS

To use Public Address, the optional PA unit (KAP-1) and external speaker must be installed by your dealer. This function amplifies audio input from the microphone and outputs amplified audio from the external speaker.

- 1 Press the function button programmed by your dealer with this function
- 2 Press **PTT** and speak into the microphone.

***Note:** To adjust the audio output from the external speaker, please use Volume Up and Down keys to get the appropriate sound.*

- 3 To return to the normal operation, press the PA function key again.

AUX

A control port has been provided for an external board, such as a Voice Scrambler. Pressing the function button programmed by your dealer, activates or deactivates the AUX port.

DTMF (DUAL TONE MULTI FREQUENCY) CALLS

MAKING A DTMF CALL

Note: To make a DTMF call, you must have an optional microphone with a DTMF keypad. Ask your dealer for more information.

There are three ways of making a DTMF call:

- Auto dialing
- Manual dialing
- Store and send dialing

■ Auto dialing

- 1 Press * key on DTMF microphone.
- 2 Press one of numeric key, 1~9.
 - Preprogrammed numbers appears on the display.
- 3 Push **PTT** to send the numbers

Note:

- ◆ Maximum length of the proprogrammed number is 16 digits.

■ Manual dialing

- 1 Press and hold the **PTT** switch.
- 2 Enter the desired digits using the microphone keypad.
 - The corresponding DTMF tones sound each time you press a key.
 - If you release the **PTT** switch, transmit mode will end even if the complete number has not been sent.
 - If your dealer has activated the Keypad Auto PTT function, you need not hold down the **PTT** switch while pressing the keys on the keypad. The DTMF code will be sent automatically when you press a key.

■ Store and send dialing

- 1 Enter the desired digits using the microphone keypad.
 - The digits appear on the display as you enter them.
- 2 After entering the complete number, press the **PTT** switch.
 - The DTMF code is transmitted after pressing the **PTT** switch.

Note:

- ◆ Store and send must first be activated by your dealer in order for it to function.
- ◆ You can only store up to 16 digits before sending. Entering more than 16 digits will cause an error tone to sound.
- ◆ In store and sending mode, if you switch the power OFF before sending the number, the number will be cleared from memory.

DTMF SIGNALLING

Your dealer can program a group or channel with DTMF signalling. When you receive a call with a code that matches yours, a tone will sound. Squelch opens and you will hear the call.

Squelch will close when you receive a call with a code that matches your signalling reset code.

When making a call on a group or channel programmed with a DTMF signalling code, the indicator will light and the squelch will open.

If your dealer programmed Transpond for DTMF signalling, your transceiver will automatically send an acknowledgment signal to the station that called you with the correct DTMF code.

DBD (DEAD BEAT DISABLE)

Depending on how your dealer programs your transceiver, when you receive a call containing a DBD code, either transmit mode or receive and transmit modes will be disabled. When a DBD code is received, a tone will sound.

DBD is cancelled when you receive a call with a DBD cancel code.