

INSTRUCTION MANUAL

TK-2170/TK-3170/TK-3173

THANK YOU!

We are grateful you chose **KENWOOD** for your land mobile radio applications. We believe this easy-to-use transceiver will provide dependable communications to keep personnel operating at peak efficiency.

KENWOOD transceivers incorporate the latest in advanced technology. As a result, we feel strongly that you will be pleased with the quality and features of this product.

NOTICES TO THE USER

WARNING:

- GOVERNMENT LAW PROHIBITS THE OPERATION OF UNLICENSED RADIO TRANSMITTERS WITHIN THE TERRITORIES UNDER GOVERNMENT CONTROL.
- ILLEGAL OPERATION IS PUNISHABLE BY FINE OR IMPRISONMENT OR BOTH.
- REFER SERVICE TO QUALIFIED TECHNICIANS ONLY.
- DO NOT OPERATE YOUR TRANSCEIVER IN EXPLOSIVE ATMOSPHERES (GASES, DUST, FUMES, ETC.).
- TURN OFF YOUR TRANSCEIVER WHILE TAKING ON FUEL, OR WHILE PARKED IN GASOLINE SERVICE STATIONS.

SAFETY:

It is important that the operator is aware of and understands hazards common to the operation of any transceiver.

WARNING:

EXPLOSIVE ATMOSPHERES (GASES, DUST, FUMES, etc.)

Turn off your transceiver while taking on fuel, or while parked in gasoline service stations.

One or more of the following statements may be applicable:

FCC WARNING

This equipment generates or uses radio frequency energy. Changes or modifications to this equipment may cause harmful interference unless the modifications are expressly approved in the instruction manual. The user could lose the authority to operate this equipment if an unauthorized change or modification is made.

INFORMATION TO THE DIGITAL DEVICE USER REQUIRED BY THE FCC

This equipment has been tested and found to comply with the limits for a Class B digital device, pursuant to Part 15 of the FCC Rules.

These limits are designed to provide reasonable protection against harmful interference in a residential installation.

This equipment generates, uses and can generate radio frequency energy and, if not installed and used in accordance with the instructions, may cause harmful interference to radio communications.

However, there is no guarantee that the interference will not occur in a particular installation. If this equipment does cause harmful interference to radio or television reception, which can be determined by turning the equipment off and on, the user is encouraged to try to correct the interference by one or more of the following measures:

- Reorient or relocate the receiving antenna.
- Increase the separation between the equipment and receiver.
- Connect the equipment to an outlet on a circuit different from that to which the receiver is connected.
- Consult the dealer for technical assistance.



ATTENTION (U.S.A. Only):

The RBRC Recycle seal found on **KENWOOD** nickel-cadmium (Ni-Cd) battery packs indicates **KENWOOD**'s voluntary participation in an industry program to collect and recycle Ni-Cd batteries after their operating life has expired. The RBRC program is an alternative to disposing Ni-Cd batteries with your regular refuse or in municipal waste streams, which is illegal in some areas.

For information on Ni-Cd battery recycling in your area, call (toll free) 1-800-8-BATTERY (1-800-822-8837). **KENWOOD**'s involvement in this program is part of our commitment to preserve our environment and conserve our natural resources.

UNPACKING AND CHECKING EQUIPMENT

Note:

The following unpacking instructions are for use by your

KENWOOD dealer, an authorized **KENWOOD** service facility, or the factory.

Carefully unpack the transceiver. We recommend that you identify the items listed in the following table before discarding the packing material. If any items are missing or have been damaged during shipment, file a claim with the carrier immediately.

: Accessories

Item	Part Number	Quantity
		K/K3
Instruction Manual	B62 – 1809 - *0	1
Belt Hook	J29 – 0701 - 05	1
Cap	B09 – 0686 - *3	1
Holder	J19 – 5483 - *3	1
Pamphlet	B59 – 2366 - *0	1

Installing/ Removing the Optional Battery Pack

The battery pack is not charged at the factory; charge it before use.

CAUTION:

- DO NOT RECHARGE THE BATTERY PACK IF IT IS ALREADY FULLY CHARGED. DOING SO MAY CAUSE THE LIFE OF THE BATTERY PACK TO SHORTEN OR THE BATTERY PACK MAY BE DAMAGED.
- AFTER RECHARGING THE BATTERY PACK, DISCONNECT IT FROM THE CHARGER. IF THE CHARGER POWER IS RESET (TURNED ON AFTER BEING TURNED OFF), RECHARGING WILL START AGAIN AND THE BATTERY PACK WILL BECOME OVERCHARGED.
- DO NOT SHORT THE BATTERY TERMINALS OR DISPOSE OF THE BATTERY BY FIRE.
- NEVER ATTEMPT TO REMOVE THE CASING FROM THE BATTERY PACK.

1 Match the guides of the battery pack with the corresponding grooves on the upper rear of the transceiver, then firmly press the battery pack t

2 Flip the safety catch into place to prevent accidentally pressing the release latch and removing the battery.

3 To remove the battery pack, lift the safety catch, press the release latch, then pull the battery pack away from the transceiver.

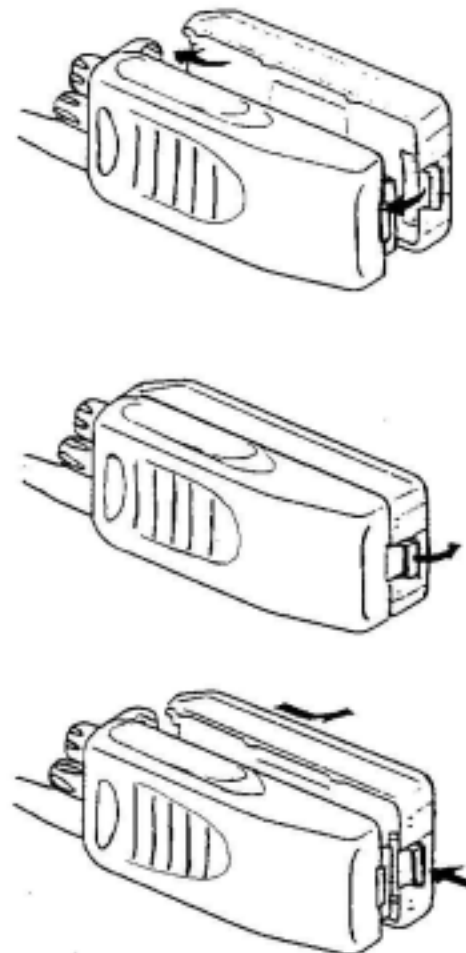

Installing the Antenna

Screw the antenna into the connector on the top of the transceiver by holding the antenna at its base and turning it clockwise until secure.

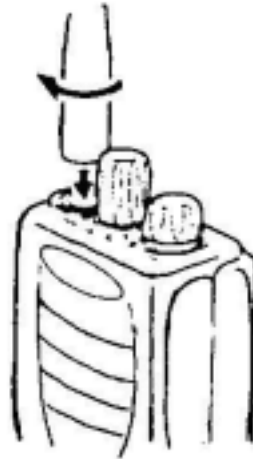

Installing the Belt Clip

1 Remove the two screws from the rear of the transceiver, then remove the small, plastic black covering that was held in place.

2 Insert the belt clip mount into the space on the rear of the transceiver.

3 Using the 2 screws, affix the belt clip in place.

Note: Do not dispose of the plastic black covering.

If you remove the belt clip, replace the covering into the space on the rear of the transceiver.

Either this covering or the belt clip must be in place, otherwise the battery pack may not remain installed properly.

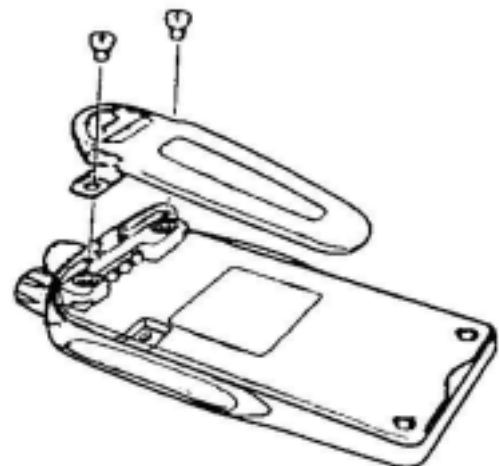
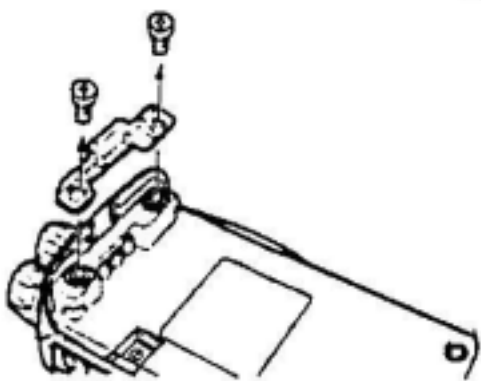

Installing the Cap over the Speaker/Microphone Jacks

If you are not using an optional speaker/ microphone, install the cap over the SP/MIC jacks.

Note:

To keep the transceiver water resistant, you must cover the SP/MIC jacks with the cap or the speaker/microphone connector.

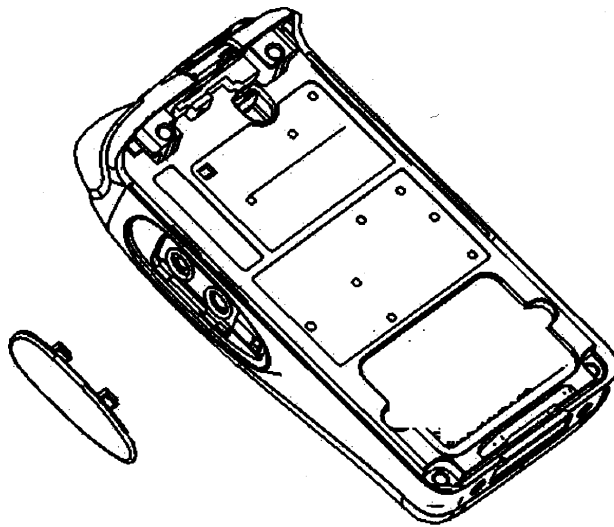

Installing the Optional Speaker/ Microphone

- 1 Insert the guide of the speaker/ microphone plugs into the SP/MIC jacks.
- 2 Insert the speaker/microphone locking Hardware Fixture over the plugs and slide down to lock.

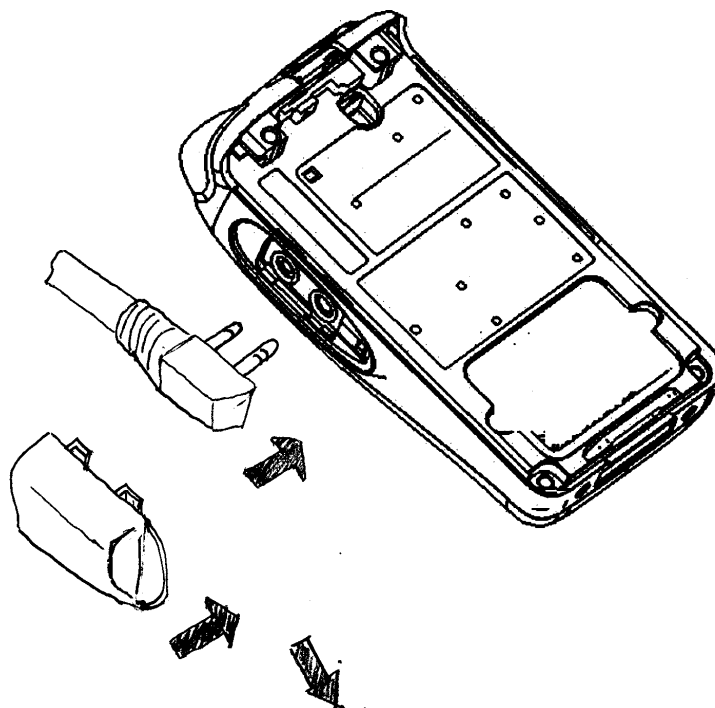

GETTING ACQUAINTED

Knob

NO.	Name	Lock/ Non Lock	Description
1	Power switch/ Volume control	Lock/ Non Lock	Power SW (CCW : Power OFF) Audio Volume adjuster
2	Selector switch	Lock	Programmable default : Zone Up/Down

Switch

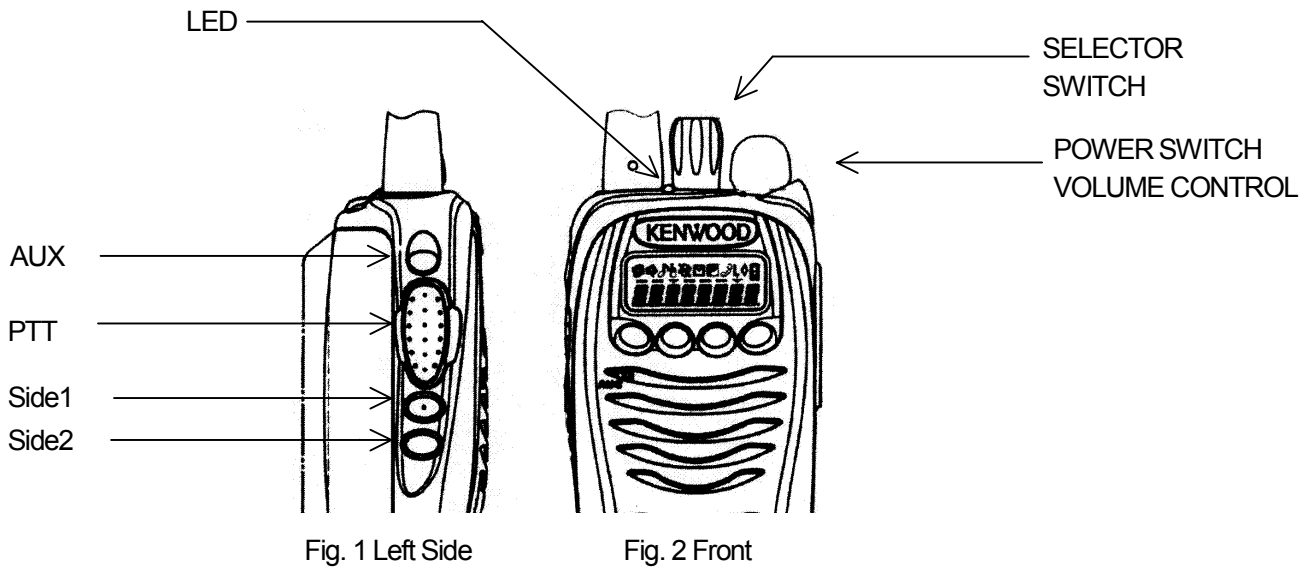

(Left side)

NO.	Name	Lock/ Non Lock	Description
1	PTT	Non Lock	TX ON/OFF
2	Side 1	Non Lock	Programmable default : Squelch Off Momentary
3	Side 2	Non Lock	Programmable default : Lamp
4	AUX(Orange)	Non Lock	Programmable default : No Function

(Front side)

NO.	Name	Lock/ Non Lock	Description
1	S	Non Lock	Programmable default : No Function
2	A	Non Lock	Programmable default : No Function
3	B	Non Lock	Programmable default : CH/GID Down

4	C	Non Lock	Programmable	default : CH/GID Up
---	---	----------	--------------	---------------------

LED

NO.	Name	Description
1	LED	The LED is three colors. Lights green while receiving at user mode. Light red while transmitting, flashes red when the battery power is low while transmitting. Lights orange when individual called.

TERMINAL

SP/MIC jacks

SP/MIC covering for blindfold mode of resin is possible.

NO.	Name	Description	I/O
1	PTT/RXD	PTT input / Serial data input	I
2	MIC	MIC input	I
3	MIC IN	To internal MIC	-
4	OPTDET	Option Detect	I
5	5MS	5V output	O
6	AE	Audio Earth	-
7	TXD	Serial data output	O
8	NC	No Connect	-
9	SPI	To internal SP	-
10	SPO	AF power output	O

Battery Terminal

It's type of spring plate. The minus terminal connect to chassis ground
 It's mounted rear side of radio and mounting instruction is slide method.

OTHER

Rear

A rail and a hook for battery installation.
 Space which affixes name plate, Model name plate
 Screw hole for belt hook installation.

Bottom

Battery release lever

Appearance

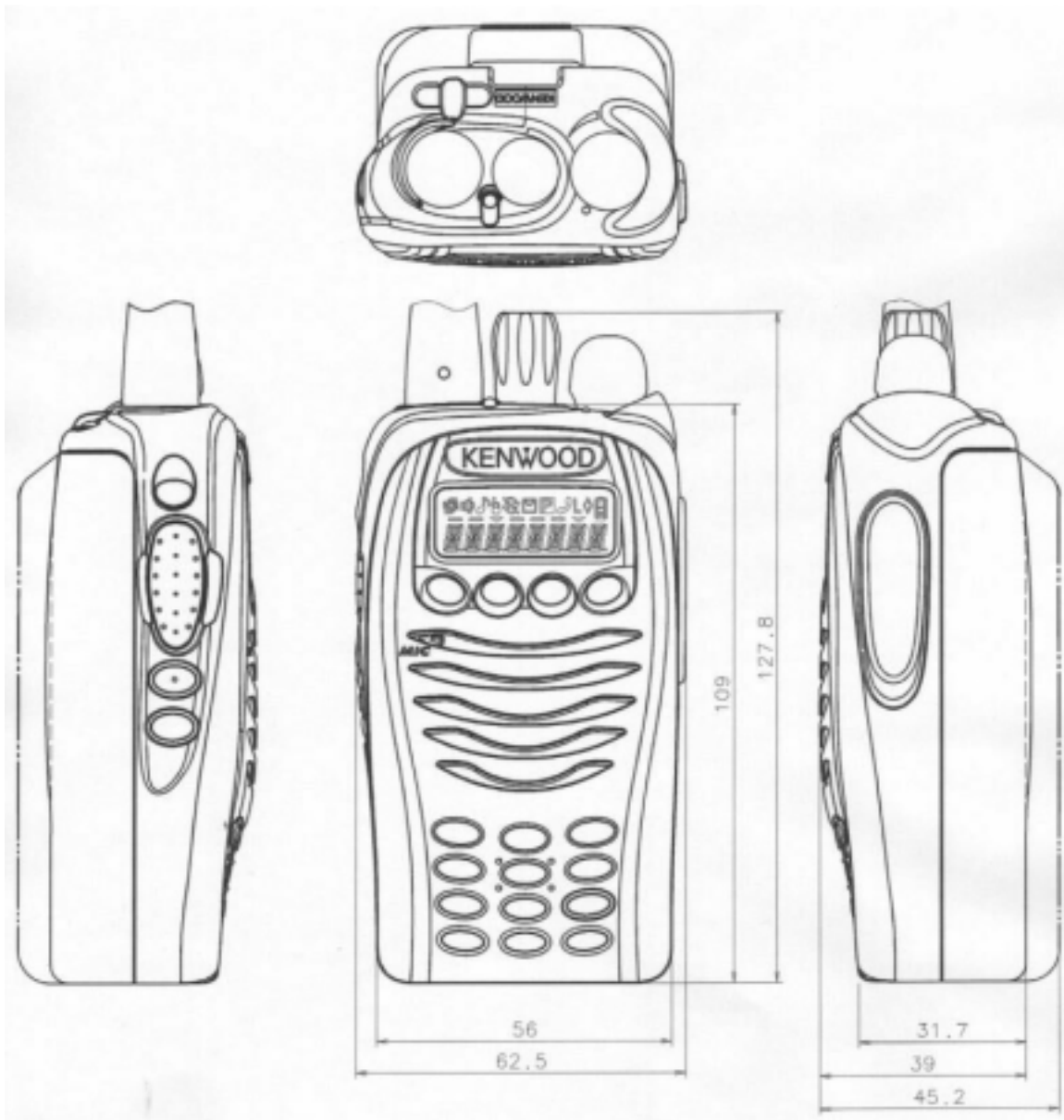

Appearance with KNB-24L

OPERATING BASICS

• **Switching Power ON/OFF**

Turn the **Power** switch/ **Volume** control clockwise to switch the transceiver ON.

Turn the **Power** switch/ **Volume** control counterclockwise to switch the transceiver OFF.

• **Adjusting the Volume**

Rotate the **Power** switch/ **Volume** control to adjust the volume.

• **Selecting a Channel**

Rotate the **Channel selector** to select a channel.

Clockwise increases the channel number and counterclockwise decreases it.

• **Making a Call**

1 Select the desired channel.

2 Press and hold the **Monitor** key (Programmed function 'Monitor') to determine whether or not the current channel is being used.

• If the channel is busy, wait until it becomes free.

3 Press and hold the **PTT** switch, then speak into the microphone in your normal voice.

• For best results, hold the microphone approximately 3 to 4 cm (1 1/2 inches) from your lips.

4 Release the **PTT** switch to receive.

AUXILIARY FEATURES

• **Time-out Timer (TOT)**

The TOT is used to automatically inhibit transmission after a specified time elapse. If the PTT switch is held down for longer than specified time, the transceiver will stop transmitting and a tone will sound. Release the PTT switch, then press it again to continue transmitting.

RADIO FREQUENCY ENERGY SAFETY INFORMATION

This **KENWOOD** transceiver has been evaluated and complies with the standards listed below, in regards to Radio Frequency (RF) energy and electromagnetic energy (EME) generated by the transceiver.

- FCC RF exposure limits for *Occupational Use Only*. RF Exposure limits adopted by the FCC are generally based on recommendations from the National Council on Radiation Protection and Measurements, & the American National Standards Institute.
- FCC OET Bulletin 65 Edition 97-01 Supplement C
- American National Standards Institute (C95.1 – 1992)
- American National Standards Institute (C95.3 – 1992)



This **KENWOOD** transceiver generates RF EME while transmitting. RF EME (Radio Frequency Electric & Magnetic Energy) has the potential to cause slight thermal, or heating effects to any part of your body less than the recommended distance from this radio transmitter's antenna. RF energy exposure is determined primarily by the distance to and the power of the transmitting device. In general, RF exposure is minimized when the lowest possible power is used or transmission time is kept to the minimum required for consistent communications, and the greatest distance possible from the antenna to the body is maintained. The transceiver has been designed for and is classified for *Occupational Use Only*. Occupational/ controlled exposure limits are applicable to situations in which persons are exposed to RF energy as a consequence of their employment, and such persons have been made aware of the potential for exposure and can exercise control over their exposure. This means you can use the transceiver only if you are aware of the potential hazards of operating a transceiver and are familiar in ways to minimize these hazards. This transceiver is not intended for use by the general public in uncontrolled environments. Uncontrolled environment exposure limits are applicable to situations in which the general public may be exposed to RF energy, or in which the persons who are exposed as a consequence of their employment may not be fully aware of the potential for exposure or cannot exercise control over their exposure.

The following list provides you with the information required to ensure that you are aware of RF exposure and of how to operate this transceiver so that the FCC RF exposure limitations are not exceeded.

- While transmitting (holding the **PTT** switch), always keep the antenna and the radio at least 3 cm (1 3/16 inches) from your body or face, as well as from any bystanders.
- Do not transmit for more than 50% of the total transceiver use time; transmitting over 50% of the total use time may exceed the limits in accordance to the FCC RF exposure requirements. Nominal transceiver operation is 5% transmission time, 5% reception time, and 90% stand-by time.
- Use only the specified antenna for this transceiver; this may be either the antenna provided with the transceiver or another antenna authorized by **KENWOOD**.

Use only **KENWOOD** authorized accessories (antennas, battery packs, belt clips, Speaker/ Mics or headsets etc.): When worn on the body, always place the radio in a **KENWOOD** recommended clip or carrying case meant for this product. The use of other than recommended or approved body-worn accessories may result in RF exposure levels which exceed the FCC's occupational/ controlled environment RF exposure limits.



To ensure that your exposure to RF EME is within the FCC limits for occupational use, you must observe and adhere to the above points.

Electromagnetic Interference Compatibility

Electronic devices are susceptible to electromagnetic interference (EMI) if they are not adequately shielded or designed for electromagnetic compatibility. Because this transceiver generates RF energy, it can cause interference to such equipment.

- Turn OFF your transceiver where signs are posted to do so. Hospitals and health care facilities use equipment that is sensitive to electromagnetic radiation.
- Turn OFF your transceiver while on board an aircraft when so instructed. Use of the transceiver must be in accordance with airline regulations and/or crew instructions.