

STEREO POWER AMPLIFIER

# BASIC M1

INSTRUCTION MANUAL

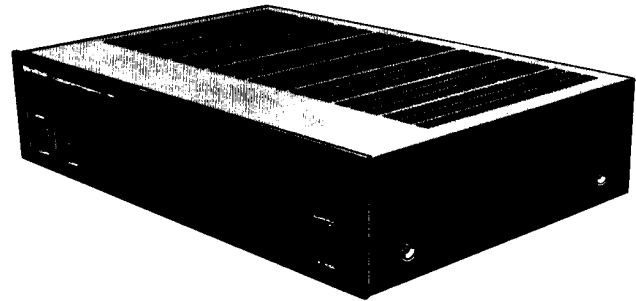

 **KENWOOD**

## Dear audio fan

The purpose of this manual is to acquaint you with the operating features of your new amplifier. You will notice that in every detail of planning, engineering, styling, operating convenience, and adaptability, we have sought to anticipate your needs and desires.

We suggest that you read this manual carefully. Knowing how to set up your amplifier to the best advantage will enhance your listening pleasure right from the start. You will also become aware of the ease with which you can adjust your amplifier to meet your special requirements.

## Contents

Before operation .....	3
System connections .....	4
Controls, indicators and connectors .....	6
In case of difficulty .....	6
Block diagram .....	7
Specifications .....	7

## For your records

Record the serial number, found on the back of the unit, in the spaces designated on the warranty card, and in the space provided below. Refer to the model and serial numbers whenever you call upon your Kenwood dealer for information or service on this product.

Model BASIC M1 Serial number \_\_\_\_\_

## Unpacking

Unpack the unit carefully and make sure that all accessories and cables are put aside so they will not be lost. Examine the unit for any possibility of shipping damage. If your unit is damaged or fails to operate, notify your dealer immediately. If your unit was shipped to you directly, notify the shipping company without delay. Only the consignee (the person or company receiving the unit) can file a claim against the carrier for shipping damage. We recommend that you retain the original carton and packing materials for use should you transport or ship the unit in the future.

## WARNING:

**TO PREVENT FIRE OR SHOCK HAZARD, DO NOT EXPOSE THIS APPLIANCE TO RAIN OR MOISTURE.**

## IMPORTANT!

### U.S.A. and Canada

Units shipped to the U.S.A. and Canada are designed for operation on 120 volts AC only. These units are not equipped with AC Voltage Selector switch and the discussion of such a switch that follows should be disregarded.

### All other countries

Units shipped to countries other than the U.S.A. and Canada are equipped with an AC Voltage Selector switch on the rear panel. Refer to the following paragraph for the proper setting of this switch.

## AC voltage selection

This unit operates on 120 volts or 220 volts AC. The AC Voltage Selector Switch on the rear panel is set to the voltage that prevails in the area to which the unit is shipped. Before connecting the power cord to your AC outlet, make sure that the setting position of this switch matches your line voltage. If not, it must be set to your voltage in accordance with the following direction.

### Note:

Our warranty does not cover damage caused by excessive line voltage due to improper setting of the AC Voltage Selector Switch.

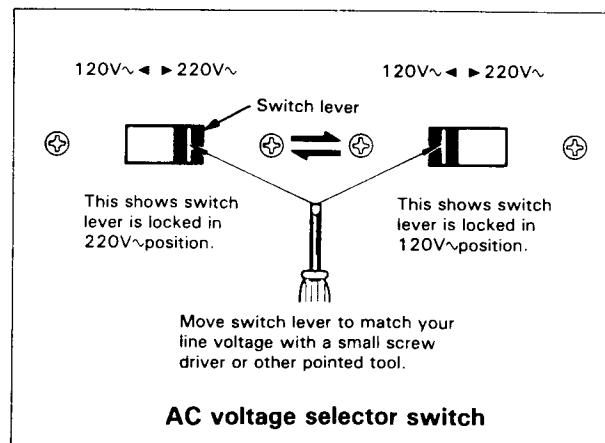

# Before operation

## Notes on installation

Do not place the unit in a place which is exposed to direct sunlight, near a heating appliance, etc.

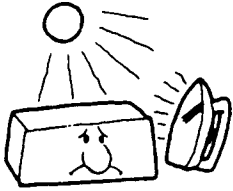

Do not place a vase containing water, makeup, etc. on the unit. Do not use in a humid place.

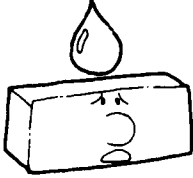

To maintain good ventilation, do not put records or a table-cloth on the unit. Place the unit at least 10 cm away from the walls.



Choose a location that is relatively free from vibration or excessive dust.

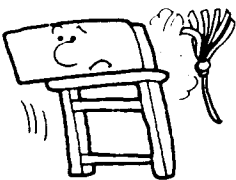

## Safety precautions

Never remove the case. If the internal parts are touched, accidentally, a serious electric shock might occur.

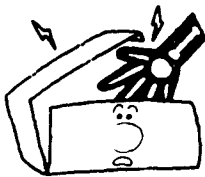

Never touch internal parts.

If a metal object, such as a hair pin or a needle, comes into contact with the power socket on the rear panel, a dangerous electric shock may result. For families with children, never permit children to put anything, especially metal, inside this unit.



Do not connect other audio equipment with a power consumption larger than that specified to the AC outlet on the rear panel. Never connect other electrical appliances, such as an iron or toaster.

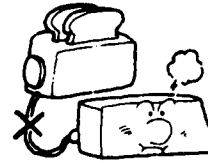

Never connect other electrical appliances.

Touching the power plug when your hands are wet may result in a serious electric shock.

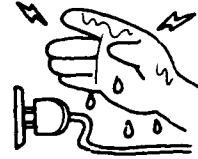

Never touch with wet hands

Never pull, bend or extend the power cord. This could damage the power cord, resulting in a broken cord or short-circuit.



Always grasp the plug.

## In case of abnormal smell

If an abnormal smell or smoke is detected, immediately turn the power OFF and pull out the power cord. Contact your dealer or nearest Kenwood Service Station.

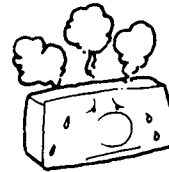

## Thermal protector

This unit employs a thermal protector which automatically shuts off the power if the temperature inside the amplifier becomes unusually high. The protector automatically restores the power when the temperature drops to the normal level and the cause of the unusual temperature rise must be removed before the power is restored. Unusually high temperatures may be caused by continuous driving of low-impedance speaker systems at high power or shorted output circuit.

## Cleaning

Do not use volatile solvents such as alcohol, paint thinner, gasoline, benzene, etc. to clean the cabinet. Use a silicone cloth or a clean dry cloth.

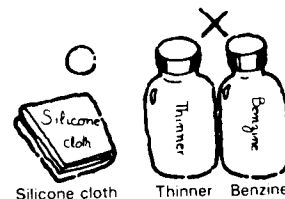

Silicone cloth Thinner Benzene

# System connections

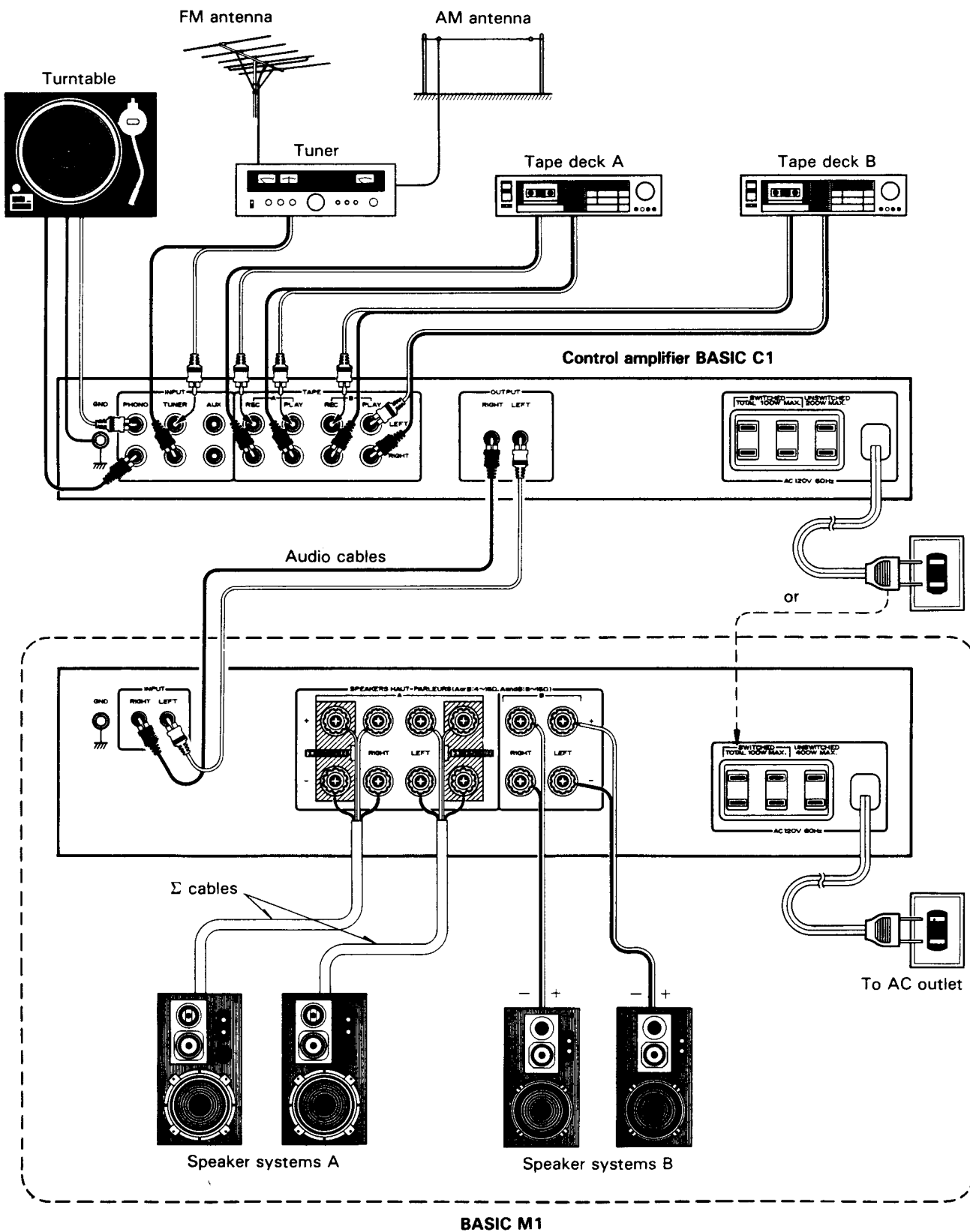

## Speakers

This amplifier has two pairs of speaker terminals, SPEAKERS A and SPEAKERS B.

### Connecting one speaker system

Connect speakers rated at 4 ohms or more to the SPEAKERS A terminals.

Although ordinary speaker cords can be connected to the SPEAKERS A terminals, the  $\Sigma$  drive system will reproduce better sound with the  $\Sigma$  cables connected to the SPEAKERS A terminals.

### Speaker cords

Fig. 1 shows ordinary speaker cords available on the market, which can be used as a  $\Sigma$  cord.

Use these cords to make the  $\Sigma$  drive system connection.

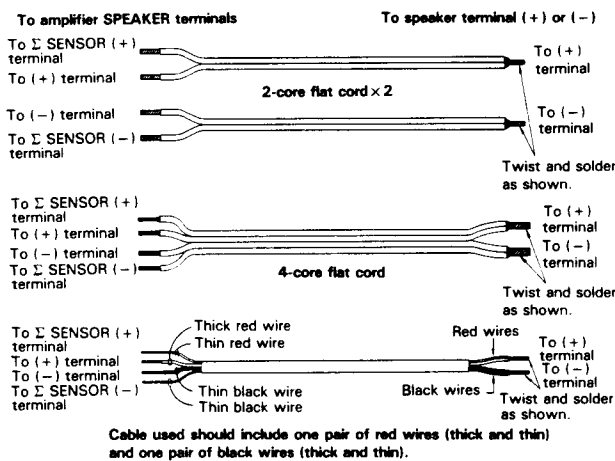

Fig. 1 Substitute cords for  $\Sigma$  Speaker Cables

### Connection with $\Sigma$ Cables ( $\Sigma$ drive system)

Each  $\Sigma$  cable has two red wires and two black wires. Connect as follows: (Fig. 2)

1. The cable to be connected to the left speaker is connected to the LEFT SPEAKERS A terminals and that to be connected to the right speaker is connected to the RIGHT SPEAKERS A terminals.
2. At the speaker end of the cable the thick and thin red wires are twisted together and soldered. This red pair is then connected to the (+) terminal of the speaker. Similarly the thick and thin black wires are twisted together and soldered. This pair connects to the (-) terminal.
3. At the amplifier end of the cable the wires are separated. The thick red and black wires connect to the (+) and (-) SPEAKERS A terminals, respectively. The thin red and black wires connect to the (+) and (-)  $\Sigma$  SENSOR terminals, respectively.
4. Connect the right and left speakers as in Step 3.

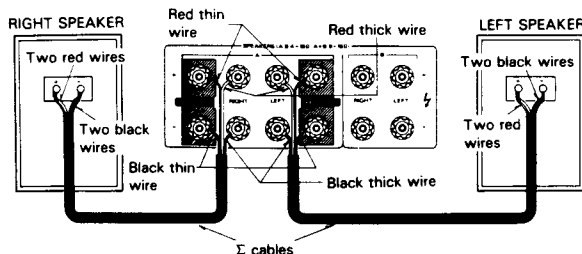

Fig. 2 Connection with  $\Sigma$  cables

### Connecting two speaker systems

To connect an additional pair of speakers, use the B terminals. Each speaker to be connected must be rated at 4 ohms or more. However, when two pairs of speakers A and B are to be driven simultaneously, be sure that each speaker to be connected to the SPEAKERS A and B terminals must be rated at 8 ohms or more.

### Connection with ordinary speaker cords

1. Connect the left speaker to the LEFT SPEAKERS terminals and the right speaker to the RIGHT SPEAKERS terminals (Fig. 3).
2. Be careful that wires do not contact adjacent terminals.
3. Be sure to connect the (+) terminal of the speaker to the (+) terminal of the amplifier.

Never short the (+) and (-) terminals.

Erroneous connection of speakers may result in poor imaging or unnatural sound.

### Note:

If the SPEAKERS A terminals are connected with ordinary cords, connect only inner terminals but not  $\Sigma$  SENSOR (shaded) terminals.

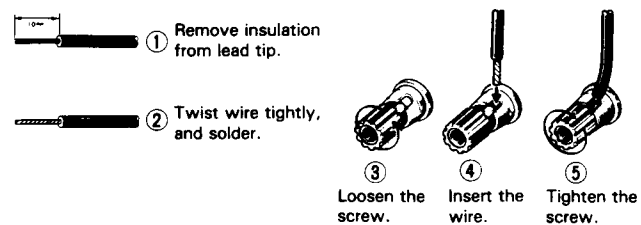

Fig. 3 Connecting speaker cords

### INPUT jacks

Connect these jacks and the OUTPUT jacks of a control amplifier with audio cables equipped with pin plugs on each end.

### Note:

To prevent possible trouble, always disconnect the power plug or turn off the POWER switch before connecting or disconnecting the audio cables.

### AC outlets

The AC outlets on the rear panel may be used to supply power to other components in the system, such as turntables, tape decks, etc. Never connect equipment whose power consumption exceeds the maximum value shown at each outlet.

1. **SWITCHED outlets:** These outlets supply power only when the unit is turned on. The maximum total capacity (both outlets) is 100 watts.
2. **UNSWITCHED outlet:** The outlet provides power when the unit is plugged into an active AC wall outlet, regardless of the setting of the POWER switch. The maximum capacity is 400 watts.

# Controls, indicators and connectors

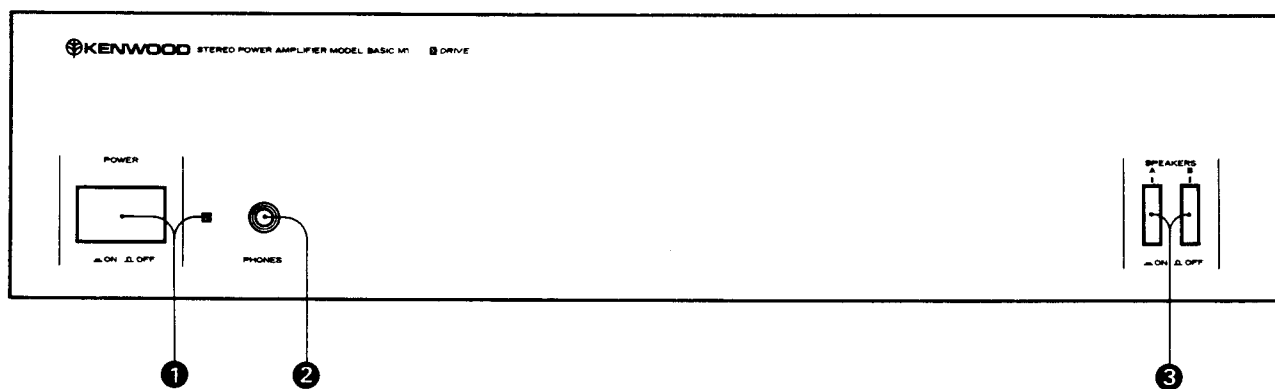

## ① POWER switch/indicator

Press the power switch to turn on the power. To turn the power off, press the switch again to set it to the out position.

## ② PHONES jack

This jack accepts the standard stereo headphone plug. When you wish to listen through headphones alone, set the SPEAKERS pushswitches (A and B) both at the OFF (Out) position.

## ③ SPEAKERS A/B pushswitches

**SPEAKERS A** — Depressing this switch to the ON (In) position will connect the output circuits of the amplifier to the speaker systems connected to the SPEAKERS A terminals on the rear of the unit.

**SPEAKERS B** — Depressing this switch to the ON (In) position will connect the output circuits of the amplifier to the speaker systems connected to the SPEAKERS B terminals on the rear of the unit.

To activate the speakers systems connected to the SPEAKERS A and B terminals, depress both the SPEAKERS A and B switches to the ON (In) position. At this time, the speakers connected to the SPEAKERS A terminals are driven without  $\Sigma$  effect.

## In case of difficulty

If your unit should not perform as expected, consult the table below to see if the problem can be corrected before seeking help from your Kenwood dealer or service representative.

AM, FM, PHONO or Tape playback	Cause	Remedy
Power on but no sound.	a) Power cord not plugged in. b) Poor connection at wall outlet. Power outlet inactive. c) VOLUME control set fully counterclockwise.	a) Check plug contact. b) Check outlet using a lamp or other appliance (outlet may be controlled by a wall switch). c) Check the control amplifier connected.
No sound from left or right.	a) Speaker cords disconnected. b) Speakers switched off. c) No input selector switch is in use.	a) Check speaker connections. b) Check speaker switch. c) Check the control amplifier connected.
Sound from left or right, but not both.	a) Poor speaker connections. b) Defective speaker. c) BALANCE set to one extreme or the other.	a) Check connections at both ends of speaker cord. b) Reverse speakers, if problem stays with speaker have speaker checked. c) Check the control amplifier connected.

# Block diagram

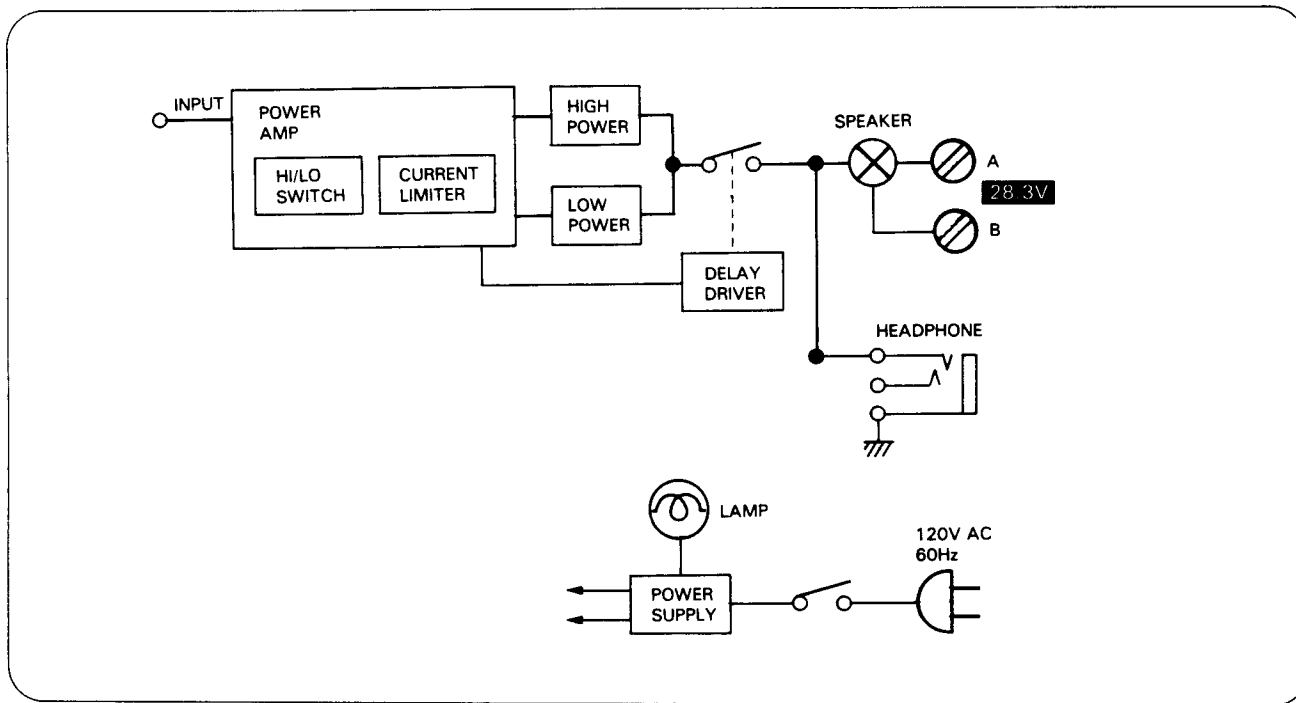

## Specifications

### Power output

105 watts per channel minimum RMS, both channels driven, at 8 ohms from 20 Hz to 20,000 Hz with no more than 0.005% total harmonic distortion.

### Clipping Power

at 8 ohms .....127 watts/ch. (1 kHz)  
at 4 ohms .....160 watts/ch. (1 kHz)

### Clipping Headroom

at 8 ohms .....0.8 dB  
at 4 ohms .....1.6 dB

### Dynamic Power

at 8 ohms .....170 watts/ch. (1 kHz)  
at 4 ohms .....210 watts/ch. (1 kHz)

### Dynamic Headroom

at 8 ohms .....2.1 dB  
at 4 ohms .....2.8 dB

### Total Harmonic Distortion

(20 Hz to 20,000 Hz)

Input to SPEAKER output .....0.005% at rated power into  
8 ohms  
0.005% at 1/2 rated power into  
8 ohms  
0.001% at rated power into  
8 ohms at 1 kHz

### Intermodulation Distortion

(60 Hz:7 kHz = 4:1) .....0.005% at rated power into  
8 ohms  
0.005% at 1 watt into 8 ohms

### Damping Factor

.....More than 1,000 at 100 Hz

### Transient Response

Rise Time .....1.2 $\mu$ s  
Slew Rate ..... $\pm 100$  V/ $\mu$ s

Frequency Response .....1 Hz to 300 kHz, -3 dB

Signal-to-Noise Ratio .....120 dB

(IHF-A Curve)

Speaker Impedance .....Accept 4 ohms to 16 ohms

### Input Sensitivity/Impedance

INPUT .....1 V/47 kohms

### General

Power Consumption .....2A (Rated power at 8 ohms)

A.C. Outlets .....Switched 2, Unswitched 1

Dimensions .....W 440 mm (17-5/16")

H 112 mm (4-27/64")

D 324 mm (12-49/64")

Net Weight .....9.1 kg (20.1 lb)

Gross Weight .....9.9 kg (21.9 lb)

\* Measured pursuant to Federal Trade Commission's Trade Regulation rule on Power Output Claims for Amplifier in U.S.A.

### Note:

Kenwood follows a policy of continuous advancements in developments. For this reason specifications may be changed without notice.