

stage

Using your
KC-Z1 Controller

KENWOOD

Licensing

Manufactured under license from Dolby Laboratories Licensing Corporation. 'Dolby', 'Pro Logic', 'AC-3', and the  symbol are trademarks of Dolby Laboratories Licensing Corporation.

Manufactured under license from Lucasfilm Ltd. US patents 5,043,970; 5,189,703; and 5,222,059. Foreign patents pending. 'THX' is a registered trademark, and 'Re-Equalization', 'Decorrelation', and 'Timbre Matching' are trademarks of Lucasfilm Ltd.

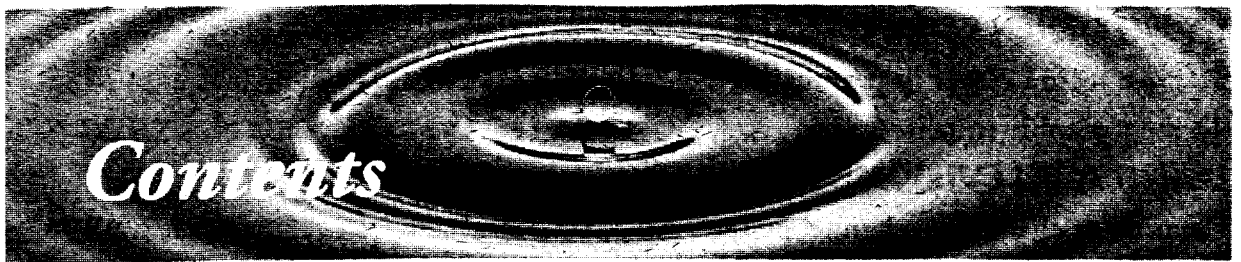

CONTENTS	3
HOW THE STAGE 3 CONTROLLER WORKS	6
The front panel controls	7
ABOUT THE TOUCHPANEL	8
How the TouchPanel sends information	8
Touching a button	8
Using the volume control	8
Using the mute control	9
Using a second set of speakers	9
About battery life	10
About the rechargeable battery	10
USING THE TOUCHPANEL	11
Using the calculator pad	13
Entering numbers	14
Creating a label	14
USING THE TUNER	15
Creating or changing a tuner preset	16
Labeling a tuner preset	17
USING A CD PLAYER	18
If you have a Kenwood SL16 CD player	19
About CD play lists	20
Changing a CD play list	21
Labeling a CD play list	22
USING A TAPE DECK	23
If you have a Kenwood SL16 cassette deck	24
USING A MINI-DISC RECORDER	25
If you have a Kenwood SL16 mini-disc recorder	25

USING OTHER COMPONENTS	26
To use a record player or personal stereo	26
To use a graphic equalizer	26
USING A TELEVISION	27
Creating or changing a channel preset	28
Labeling a channel preset	29
USING A CABLE OR SATELLITE TUNER	30
About presets	31
Using the DSS program guide navigator screen	31
USING A VCR	32
About recording	32
USING A LASERDISC PLAYER	33
Using the laserdisc multi-speed modes	34
USING A DVD PLAYER	35
ADJUSTING SOUND	38
Saving your settings	38
Accessing sound controls	39
About Surround Auto	39
ABOUT THE AUDIO MODES	40
ADDING SOUND PROCESSING	42
Adjusting bass and treble	44
Adjusting DSP Logic	45
Adjusting for quiet listening	46
ADJUSTING SPEAKER DELAY AND LEVEL	47
SELECTING THE AUDIO INPUT TYPE	48
About digital recording	48
RECORDING	49
General instructions for the Recording Studio	49
About the cassette deck recording controls	51
If you have a Kenwood SL16 cassette deck	51
About the Mini-Disc recording controls	52
If you have a Kenwood SL16 mini-disc recorder	52
About the VCR recording controls	53
CREATING SYSTEM PRESETS	54
Creating or changing a system preset	55
Playing a system preset	56
Labeling a system preset	56
Setting a system preset alarm	57

CONTROLLING ACCESSORIES	58
SETTING THE ANALOG INPUT LEVEL	60
RE-CALIBRATING THE TOUCHPANEL	61
TROUBLESHOOTING	62
SPECIFICATIONS	67

How the Stage 3 Controller works

Your new Stage 3 Controller is designed to let you operate all of your entertainment components—your TV, VCR, laserdisc or DVD player, CD player, even automatic curtain-closers and light dimmers if you have them—with one simple instrument: the TouchPanel. Remember that before you can use the TouchPanel to operate these components, they must be connected to the Controller and set up (see *Setting up your Stage 3 Controller* for details).

You also use the TouchPanel to operate the functions of the Stage 3 Controller itself:

- FM/AM radio
- Home theater surround sound options, which includes playing movies in Dolby Surround Pro Logic or Dolby Digital (AC-3)
- Sound processing options, which includes speaker balance and delay, treble and bass adjustments, THX Cinema, and DSP Logic
- System presets and alarms, which allow you to program the Controller to carry out

The front panel controls

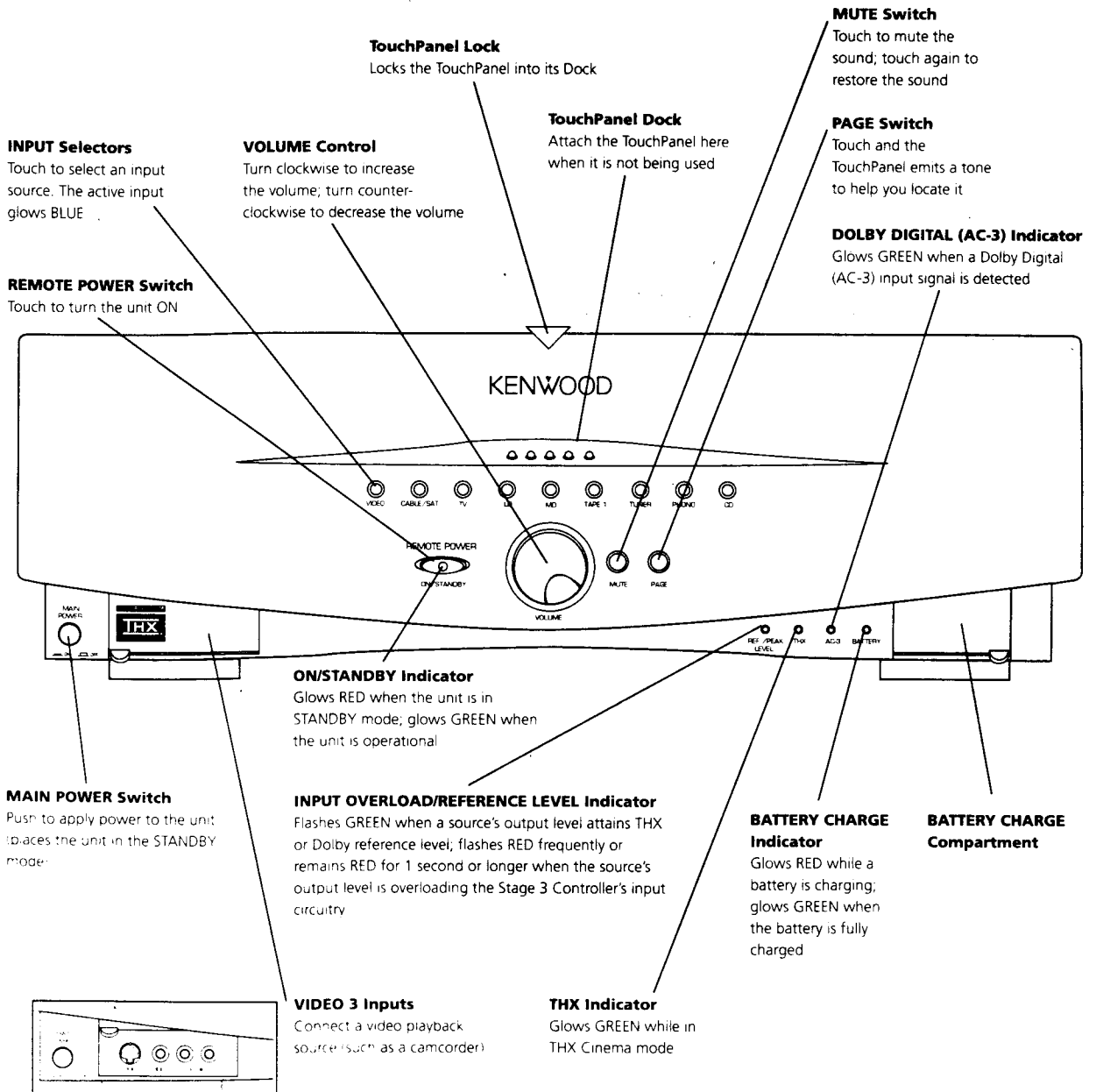

About the TouchPanel

How the TouchPanel sends information

The TouchPanel communicates with the Controller using radio waves, so you can operate the controller from anywhere within approximately 100 feet of it.

Touching a button

When you touch a button, the TouchPanel responds with a chirp sound so you get audible feedback.

Using the volume control

When you use the TouchPanel to change the volume, it displays a volume indicator.

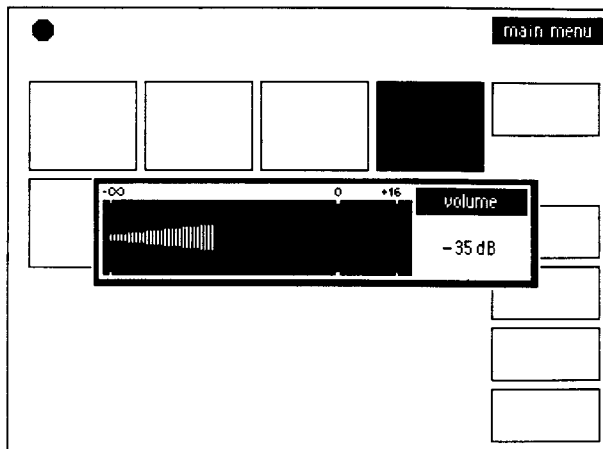

- Each time you push the VOLUME buttons, the volume changes in 1 dB increments. If you hold the button down, the volume changes continually.
- The volume indicator disappears about 2 seconds after you finish adjusting the volume.
- If you change the volume using the knob on the Controller, the volume indicator does not display. However, the next time you change the volume using the TouchPanel, the new volume level will be displayed.
- When you turn the Controller on after it has been powered-down, the volume automatically resets to a low level, no matter what the volume setting was when the Controller was powered-down. This prevents accidental damage to the system and avoids a sudden burst of loud music.

Using the mute control

You can instantly set the volume to zero (mute) by pressing the MUTE button. Pressing it again restores the volume. When the Mute function is activated, the TouchPanel displays this screen:

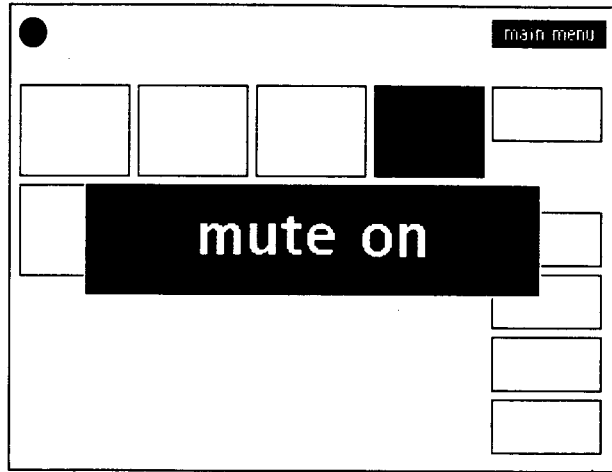

Using a second set of speakers

If you've set up your system to do so, you can use the TouchPanel to control a second set of speakers independently of the main speakers in your system. Touch the REMOTE SPEAKER VOLUME button on the Main Menu. The TouchPanel displays the remote volume indicator.

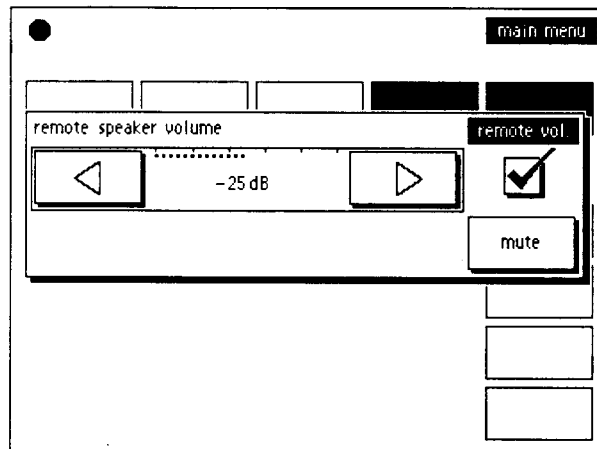

- Each time you push the volume arrow buttons, the volume changes in 1 dB increments. If you hold the button down, the volume changes continually.
- The volume indicator disappears about 2 seconds after you finish adjusting the volume.
- When you turn the Controller on after it has been powered down, the volume automatically resets to a low level, no matter what the volume setting was when the Controller was powered down. This prevents accidental damage to the system and avoids a sudden burst of loud music.

About battery life

Under constant use (with the LCD display constantly lit), a fully-charged battery will last 4 to 5 hours before it needs to be recharged. Under normal use (the LCD display set to shut off a few seconds after it's used), the battery should last much longer. See "Setting the LCD Sleep Time" for instructions on adjusting the TouchPanel to help maximize battery life.

The TouchPanel screen will display the following message when its battery needs recharging:

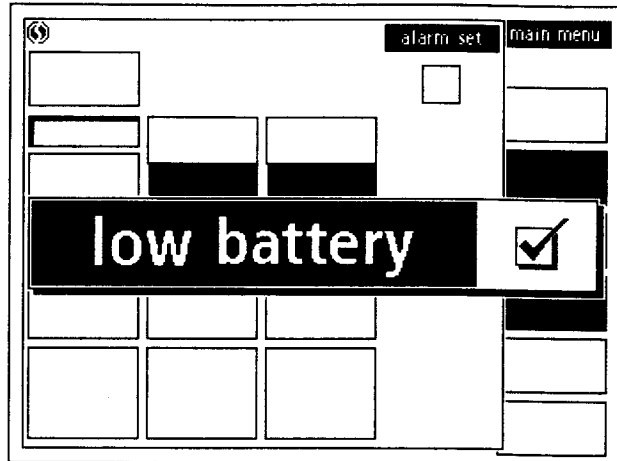

- Exchange the battery with the fully-charged extra battery in the controller's Battery Compartment.
- The batteries can be recharged and reused approximately 250 times. You will know a battery is nearing the end of its life when its use time shortens.
- Only use DURACELL DR-17 batteries.

About the rechargeable batteries

- When batteries need recharging, recharge them as soon as possible. Also, do not expose the batteries to high temperatures. This will help the batteries maintain their charge.
- For more information about batteries, contact Duracell directly at 800-551-2355.

Using the TouchPanel

When you've finished connecting your components and setting them up, the TouchPanel's Main Menu will look something like the screen below.

At any time, to get to the MAIN MENU screen, touch this button:



The main menu

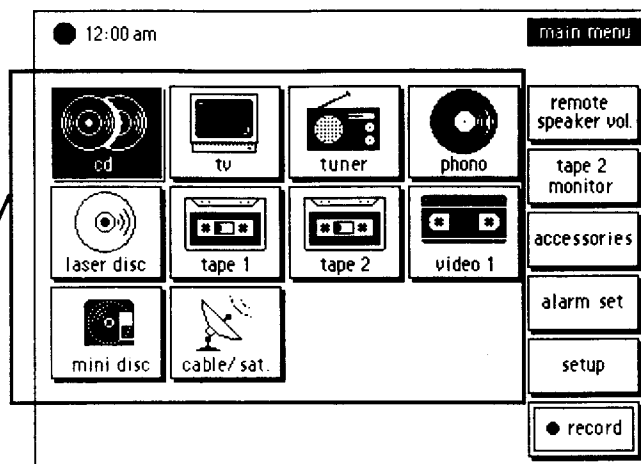

**SELECTION
BUTTONS**
Allow you to
activate or adjust
different functions

COMPONENT BUTTONS

These buttons show you the components you have connected to the Controller, and will look different than this example depending on the components you've installed. Each of these component buttons takes you to a screen you can use to operate the component shown.

About SL16 components

If a function is not available with your Kenwood SL16 component, an icon still displays on the TouchPanel the first time you use it. It will disappear after the TouchPanel communicates with the component.

Other TouchPanel buttons and indicators

No matter which TouchPanel screen you are on, general controls and indicators are available.

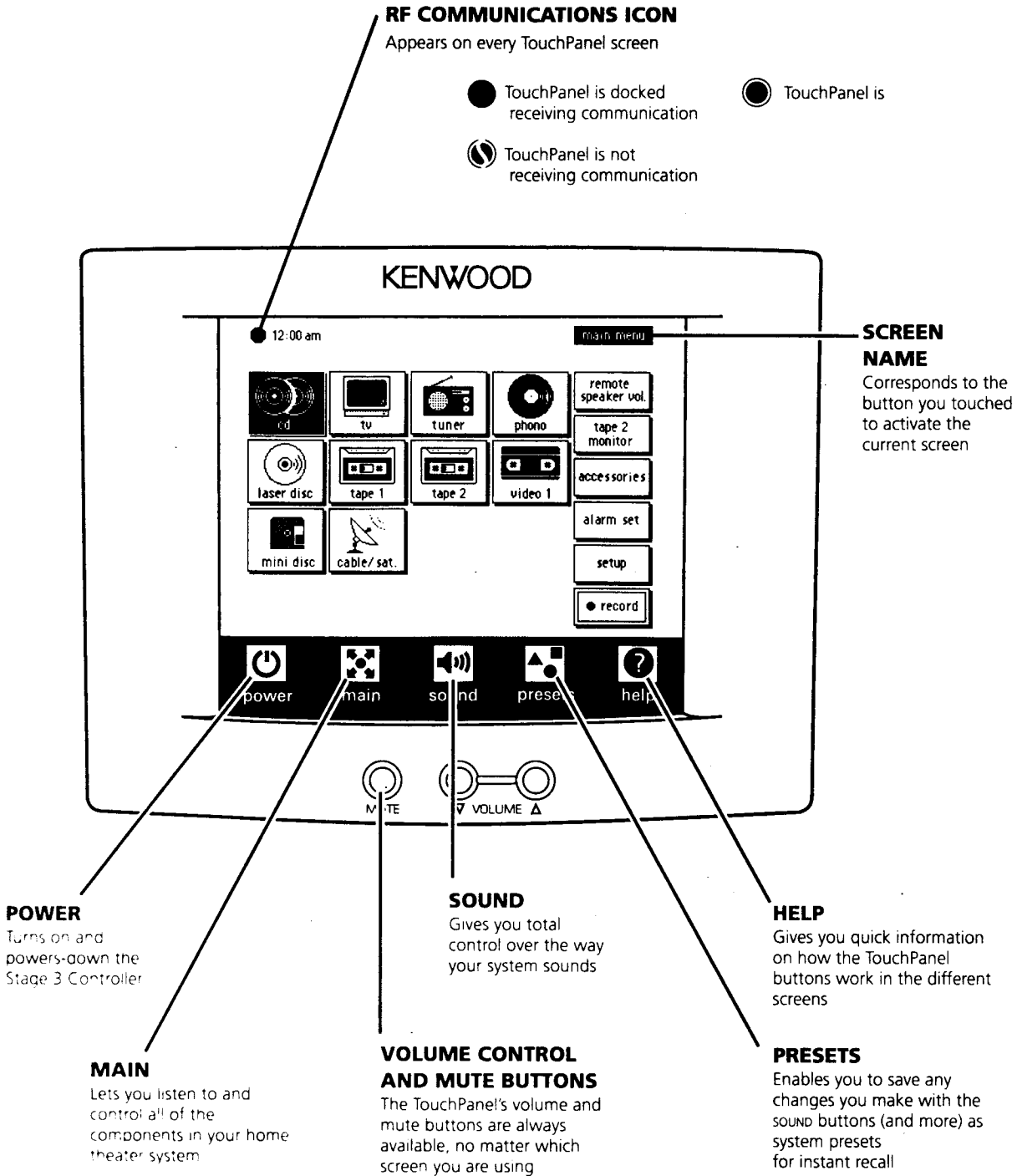

About the auto-off feature

The TouchPanel turns itself off after a period of time if it hasn't been used. This feature saves battery power, and can be adjusted (see *Setting up your KC-Z1 Controller*). To reactivate the TouchPanel, simply touch it again.

Using the calculator pad

Anytime you need to enter a number or create a label, the TouchPanel displays the calculator pad. Here's how to use it.

Entering numbers

- 1 Enter the number using the NUMBER buttons.
- 2 Touch the ENTER button to accept the number.
- 3 Touch the CHECK-MARK to save what you entered. No change is made if you use the CHECK-MARK before the ENTER button.

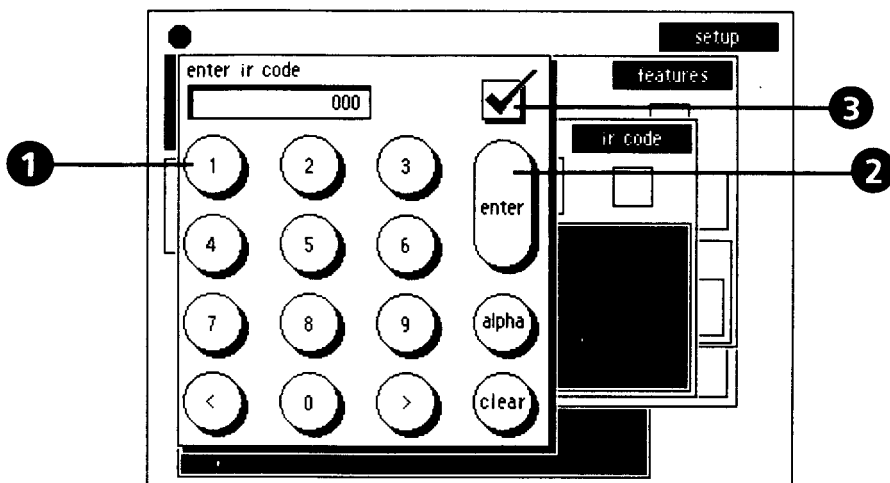

NOTE: The calculator pad in the DVD control screens has additional functions. See *Using a DVD Player* (page 35) for details.

Creating a label

- 1 Touch the ALPHA button on the Calculator Pad.
- 2 Touch the LETTER buttons to enter letters. Touch once for the first letter, twice for the second letter, three times for the third letter. Touch the ARROW FORWARD button to enter the next letter.
- 3 Touch the ENTER button to accept the label.
- 4 Touch the CHECK-MARK to save the label. No change is made if you use the CHECK-MARK before the ENTER button.

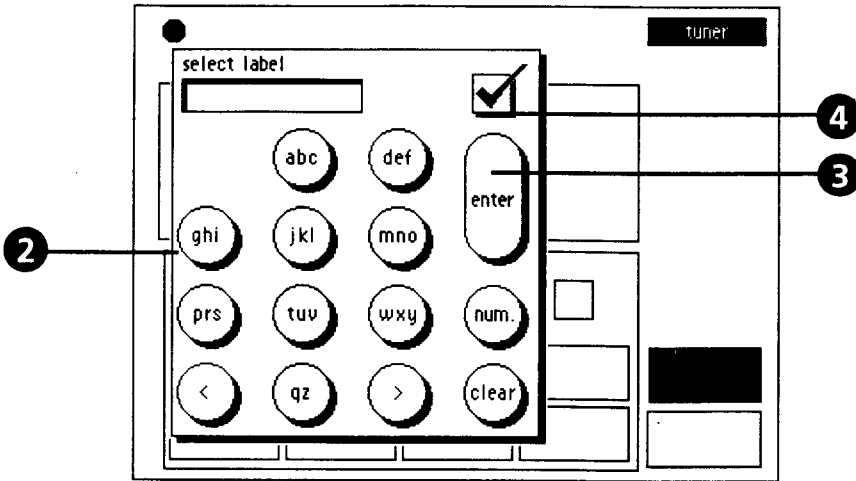

Using the tuner

You can use the Tuner screen to tune and play radio stations, set station presets, and begin recording from a radio station.

To get to the Tuner screen, touch these buttons:

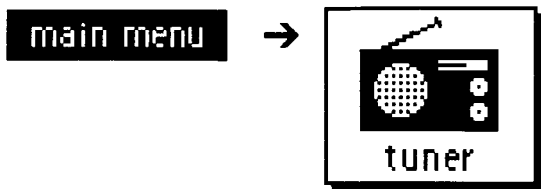

The Tuner screen

tuned stereo Lights whenever a station is tuned in

tuner Lights whenever a signal is being received in stereo

In Manual mode, scans the frequency band. In Auto mode, tunes to the next higher or lower station.

Choose AM or FM

Select stereo or mono FM reception

Fine-tune a station (stations are received in mono)

Automatically tune from one strong station to the next

Select a station with the Calculator Pad

Displays additional presets and the buttons for memorizing and labeling presets

Preset button set to a station

Preset button set to a station and labeled

Preset button that has not been programmed

Starts the Recording Studio to record the currently playing station

The Tuner screen interface includes a central display showing the frequency '91.5 MHz'. Above the display are 'tuned' and 'stereo' indicators. Below the display are buttons for 'mono', 'fm', and 'manual'. At the bottom are buttons for 'stereo', 'am', and 'auto'. A row of preset buttons is at the bottom, including '101.9 fm', 'jazz', '790 talk', and an empty slot. A 'more presets' button and a 'record' button are also present.

Creating or changing a tuner preset

- 1 On the Tuner screen, touch the MORE PRESETS button to display the Select Preset pop-up.
- 2 Tune the frequency you wish to program.
- 3 Touch the MEMORY button. The Stage 3 Controller temporarily memorizes the frequency.
- 4 Touch any TUNER PRESET button. The TouchPanel applies the memorized frequency to that button and changes the label to the frequency number. If you would like to change the label, see 'Labeling a tuner preset' next.
- 5 Repeat steps 2 to 4 for any other stations you want to set.
- 6 When you are done, touch the CHECK-MARK to return to the Tuner screen.

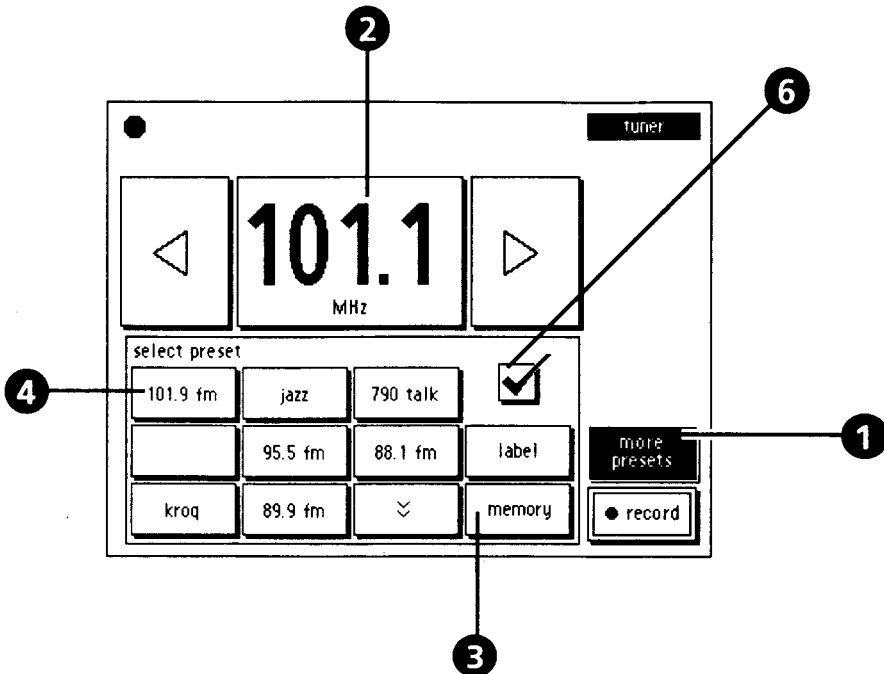

Labeling a tuner preset

- 1 On the Tuner screen, touch the MORE PRESETS button to display the Select Preset pop-up.
- 2 Touch the LABEL button.
- 3 Touch any TUNER PRESET button you've already preset. (Use the arrow buttons to view more presets). The TouchPanel displays the Calculator Pad.
- 4 Use the Calculator Pad to create a label.
- 5 Repeat steps 2 to 4 for any other stations you want to label.
- 6 When you are done, touch the CHECK-MARK to return to the Tuner screen.

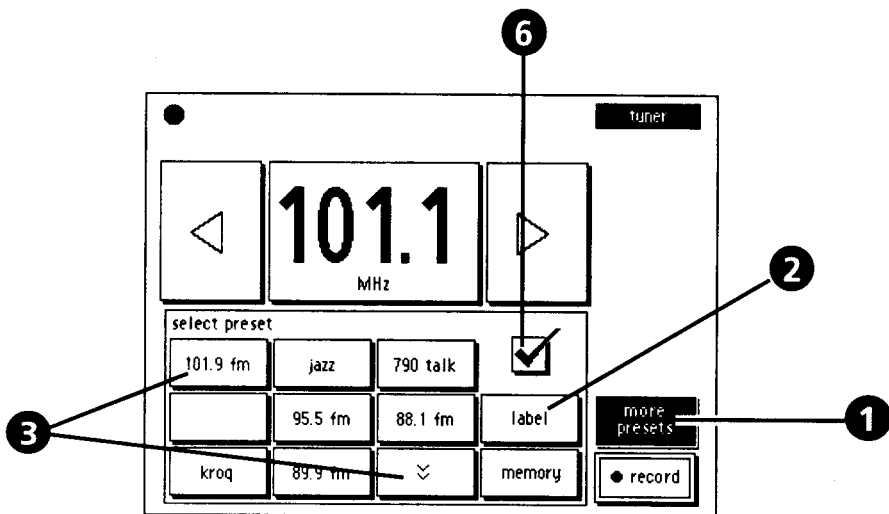

Using a CD player

You can use the CD screen to play CD's, search for specific tracks, and begin recording from a CD.

To get to the CD screen, touch these buttons:

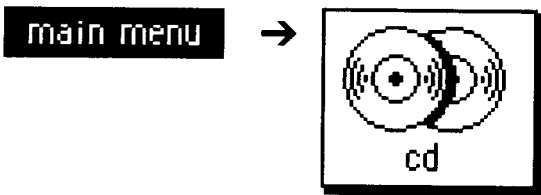

The CD screen

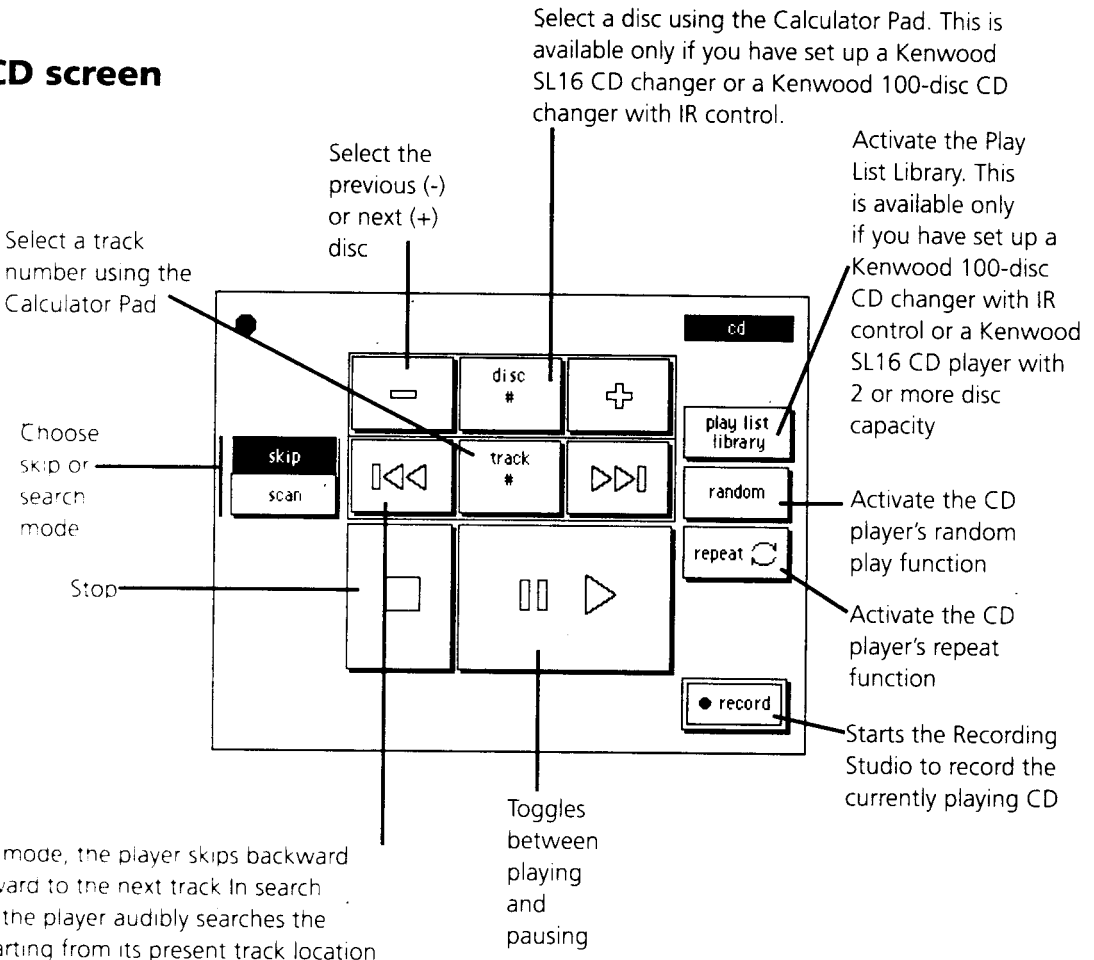

If you have a Kenwood SL16 CD player

Kenwood SL-16 CD players send information back to the TouchPanel. This means you'll see more information displayed if you're using one of these players:

- The TouchPanel's DISC and TRACK buttons will display the currently playing disc and track numbers.
- The TouchPanel will show separate PLAY and PAUSE buttons instead of the combination PLAY/PAUSE button.
- The TouchPanel's STOP, PAUSE, and PLAY buttons will remain dark when they're in use (instead of just momentarily turning dark) to let you know which mode is active.

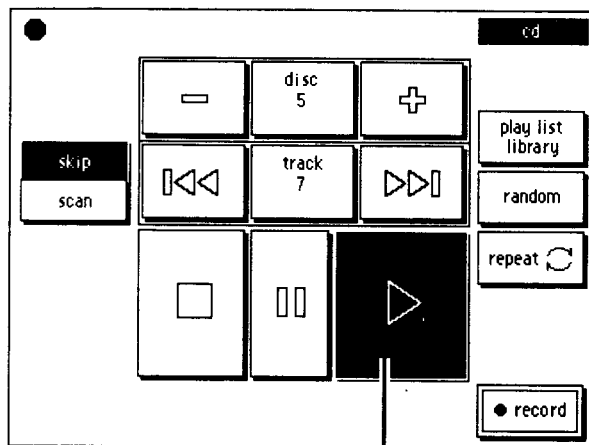

Dark button
shows play
is active

About CD play lists

If you have a Kenwood SL16 CD player that holds 2 or more discs, or a Kenwood 100-disc CD changer with IR control, you can use the TouchPanel to create and play custom combinations of songs. You can create up to 6 different play lists, each with up to 30 different songs, taken from any combination of CDs. If you have set up one of these CD changers and the PLAY LIST LIBRARY icon does not appear on the Kenwood CD control screen, check to be sure that you properly set up the CD player.

To get to the CD Play List pop-up, touch these buttons:



The Play List pop-up

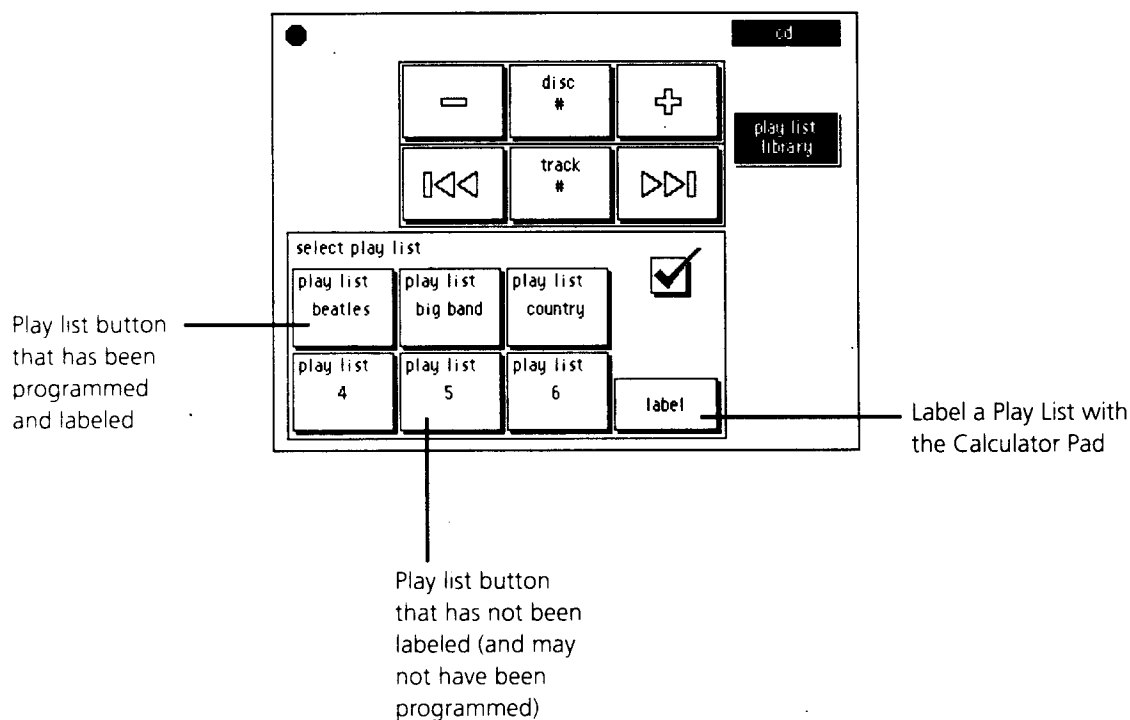

Touch the CHECK-MARK to exit from the Play List pop-up and return to the CD screen.

Creating a CD play list

- 1 On the CD Play List pop-up, touch the button for the Play List you want to create.
- 2 Touch the DISC # button and enter the disc number using the Calculator Pad that appears.
- 3 Touch the TRACK # button and enter the track number using the Calculator Pad that appears.
- 4 Touch the MEMORY button to memorize your disc and track numbers.
- 5 Touch an ENTRY button. The TouchPanel applies the memorized selections to that button and changes the label to show the disc and track numbers.
- 6 Repeat steps 2 to 5 for each track you want to add to the Play List.
- 7 If you want to play the Play List, touch the and PLAY PLAY LIST button.
- 8 When you're done, touch the CHECK MARK to return to the CD screen.

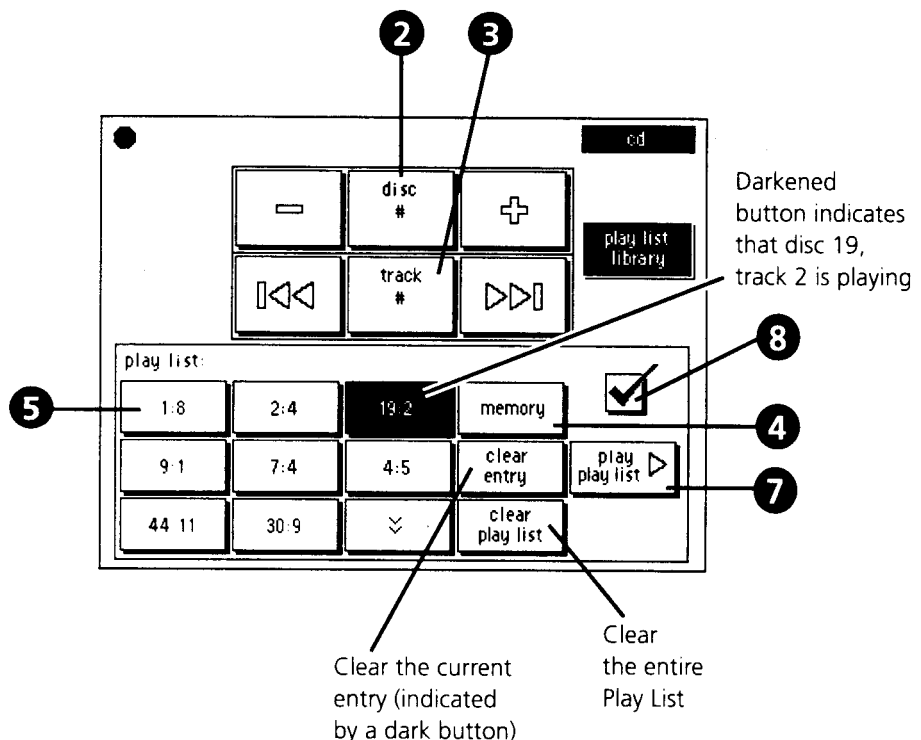

NOTE: Because your CD Player will play the songs as you program them, you may want to turn it off while you create a Play List.

Labeling a CD play list

- 1 On the Select Play List pop-up, touch the LABEL button.
- 2 Touch the PLAY LIST you would like to label. The TouchPanel displays the Calculator Pad.
- 3 Enter a number or name for your Play List with the Calculator Pad. Any combination of letters and numbers is fine, up to 8 characters.
- 4 Touch the ENTER button to accept your label entry.
- 5 Touch the CHECK-MARK on the Calculator Pad. The label is applied to the PLAY LIST button and you are returned to the CD Play List screen.

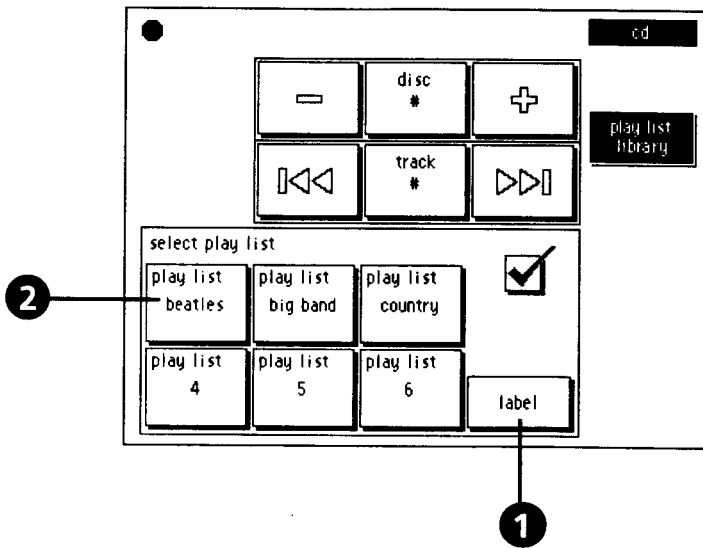

Using a tape deck

You can use the Tape screens (one for each of the up to 2 tape decks you have connected) to play tapes or start recording from a tape.

To get to a Tape screen, touch one of the tape buttons:

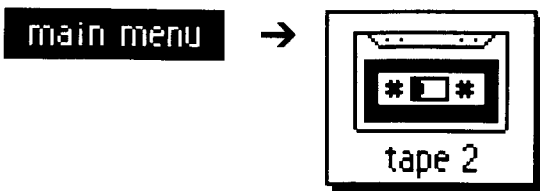

The Tape screen

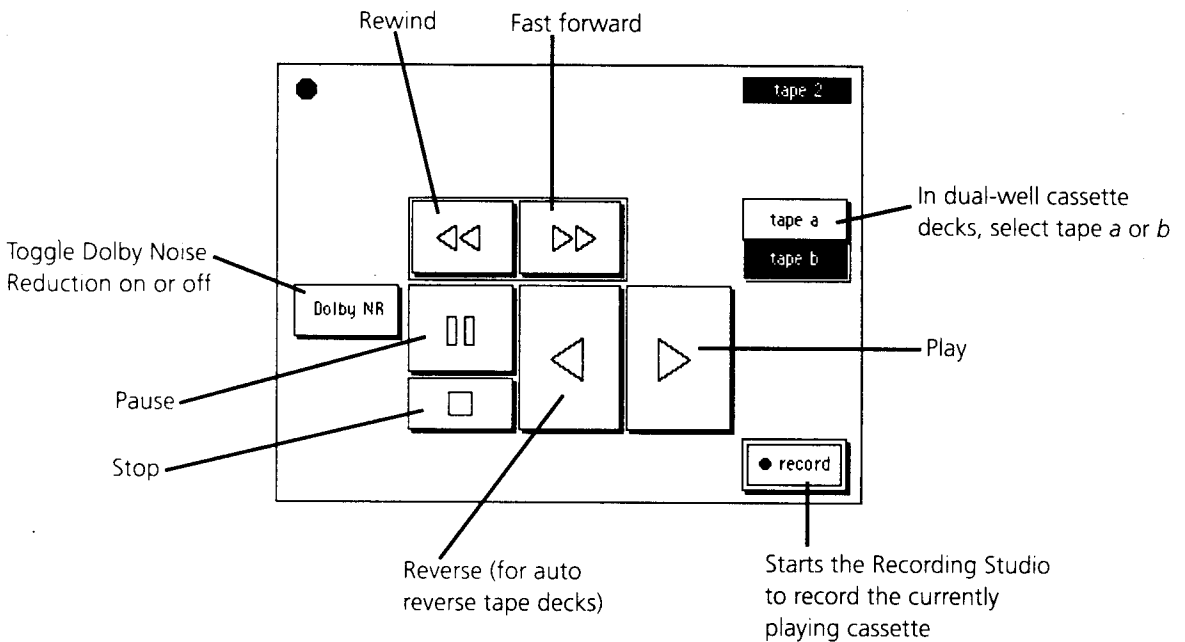

If you have a Kenwood SL16 cassette deck

Kenwood SL16 cassette decks send information back to the TouchPanel. This means you'll have additional controls (on Tape-1 only) if you're using one of these decks.

- The TouchPanel's STOP, PAUSE, PLAY, FAST FORWARD and REVERSE (SKIP and NORMAL mode) buttons will remain darkened when they're in use (instead of just momentarily turning dark), letting you know which mode is currently active.

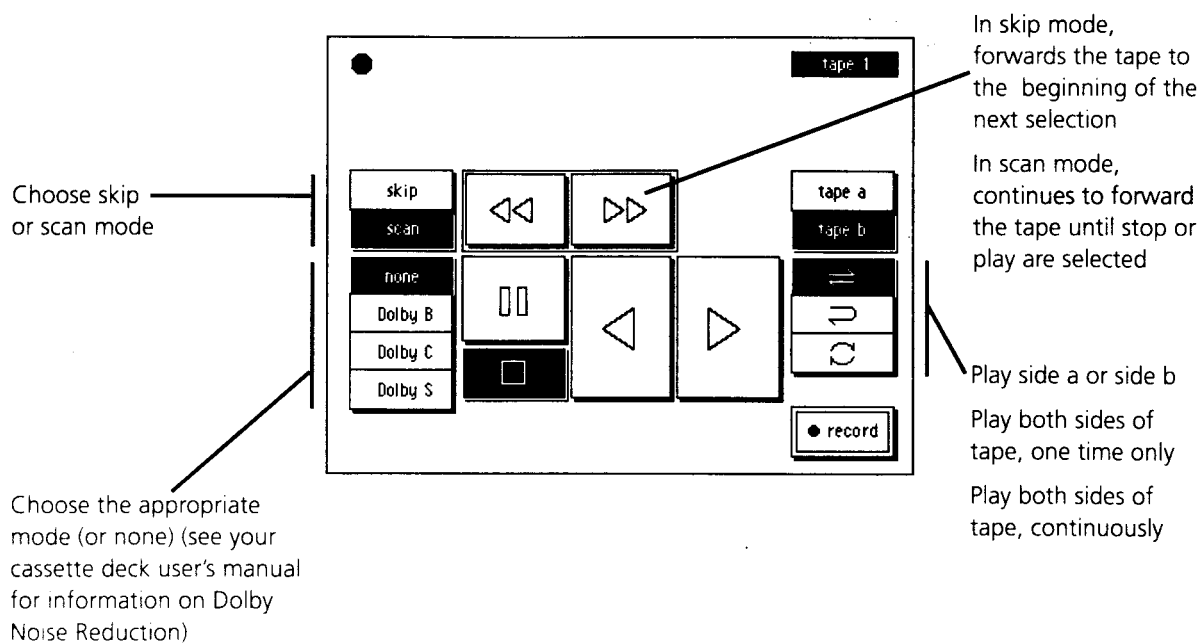

Using a mini-disc recorder

You can use the Mini-Disc screen to play mini-discs, search for specific tracks, or begin recording from a mini-disc.

To get to the Mini-Disc screen, touch these buttons:

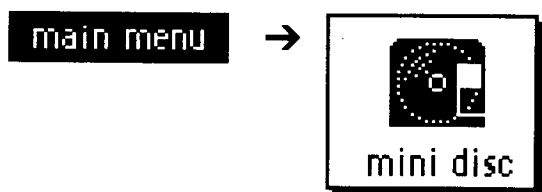

The Mini-Disc screen

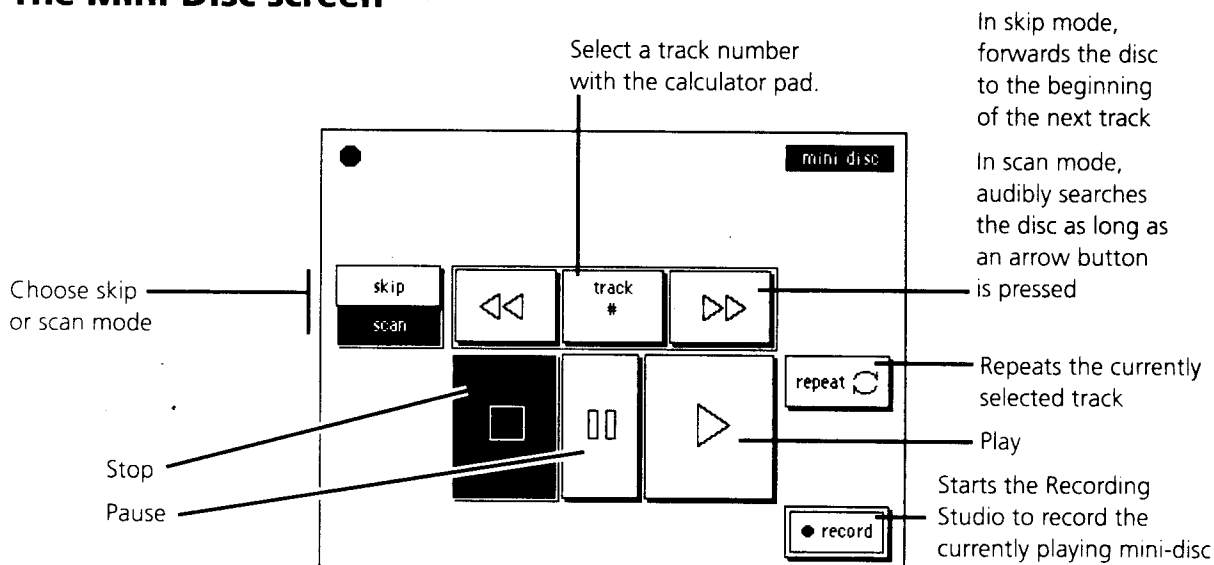

If you have a Kenwood SL16 mini-disc recorder

Kenwood SL16 mini-disc recorders send information back to the TouchPanel. This means you'll see more information displayed if you're using one of these players.

- The TouchPanel's TRACK button will display the currently playing track number.
- The TouchPanel's STOP, PAUSE, PLAY, FAST FORWARD and REVERSE (SKIP and NORMAL mode) buttons will remain darkened when they're in use (instead of just momentarily turning dark), letting you know which mode is currently active.

Using other components

You can use a record player, personal stereo, or graphic equalizer with your system, even though they can't be controlled by the TouchPanel. To set up this type of unit, see *Setting up your KC-Z1 Controller*. Here's how to use such a device once you have it set-up:

To use a record player or personal stereo

- ➊ Turn the component power on.
- ➋ Touch the COMPONENT icon from the MAIN menu.
- ➌ Begin play using the component's controls.
- ➍ Modify sound settings from the Sound menu if you wish.

To use a graphic equalizer

- ➊ Turn the graphic equalizer power on.
- ➋ Use the graphic equalizer's controls according to that component's instructions.

The graphic equalizer will not appear as a component icon on the TouchPanel screen, since it is not a sound-producing component.

Using a television

You can use the TV screen to select TV stations, set up channel presets, and begin recording from a TV station.

To get to the TV screen, touch these buttons:

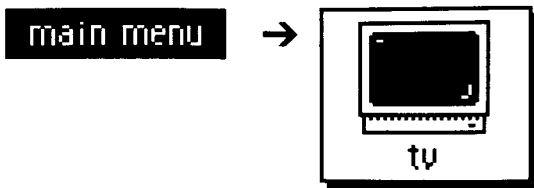

The TV screen

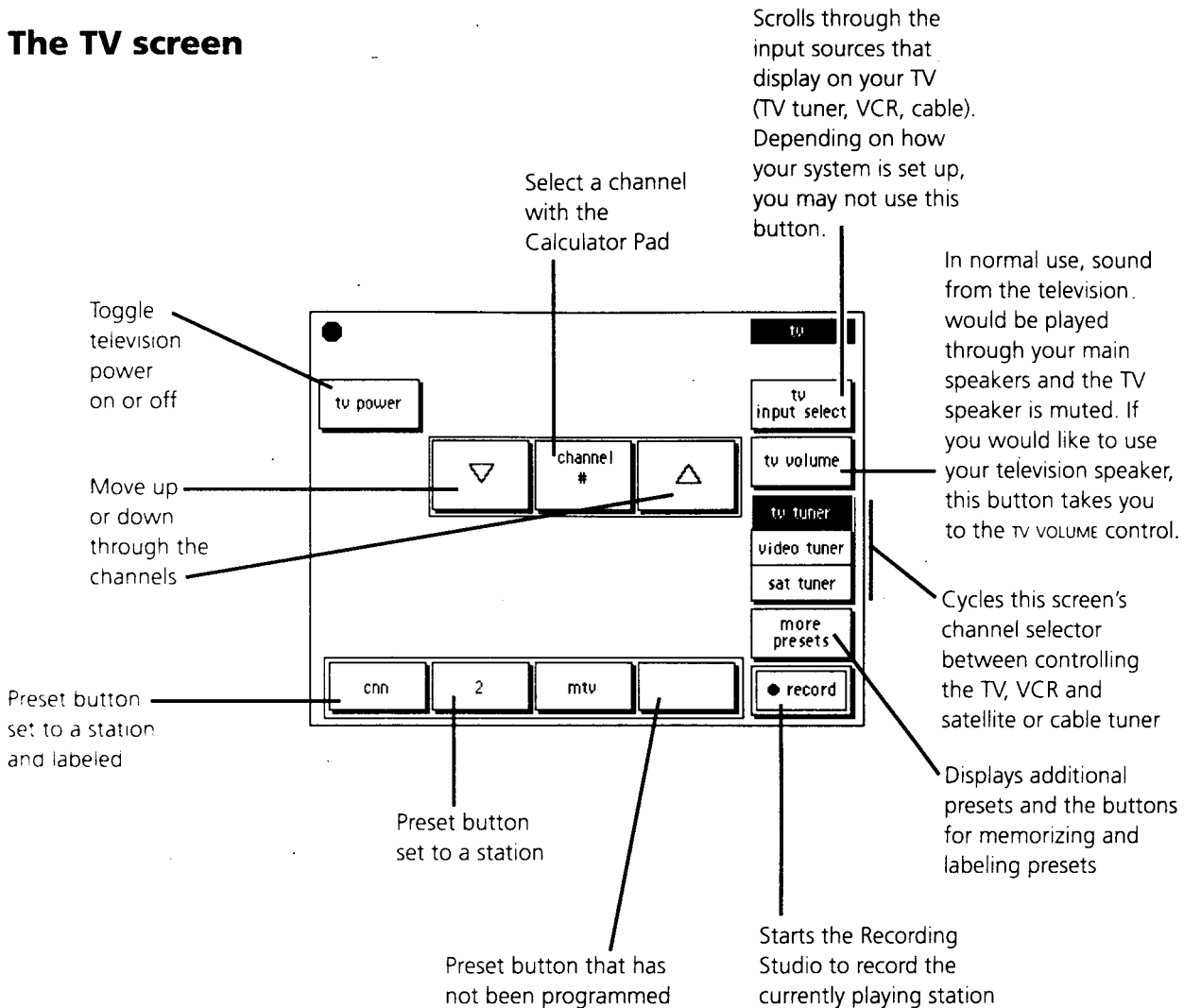

Creating or changing a channel preset

- 1 On the TV screen (on the TouchPanel), touch the MORE PRESETS button.
- 2 Tune the channel you wish to program
- 3 Touch the MEMORY button. The Stage 3 Controller temporarily memorizes the channel.
- 4 Touch any CHANNEL PRESET button. The TouchPanel applies the memorized frequency to that button and changes the label to the channel number.
- 5 When you are done, touch the CHECK-MARK to return to the TV screen.

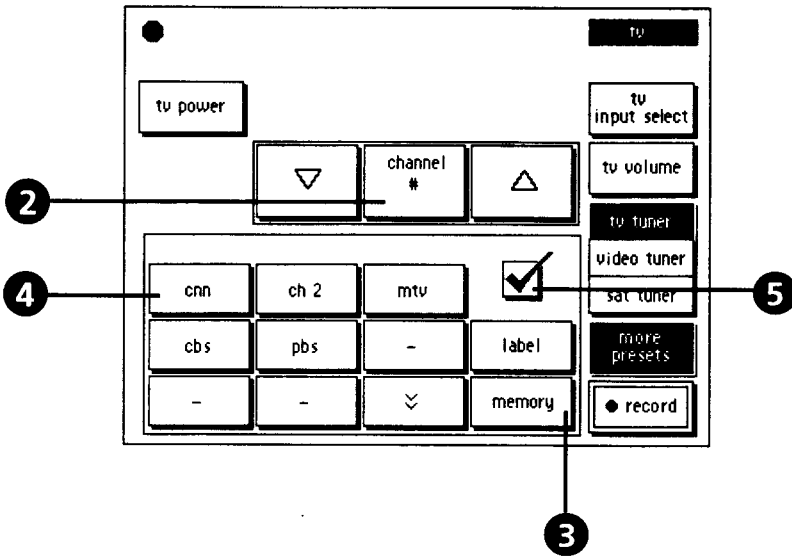

Labeling a channel preset

Instead of the channel number, you can label Preset buttons to display the channel name (such as 'CBS' or 'MTV').

- 1 On the TV screen (on the TouchPanel), touch the MORE PRESETS button.
- 2 Touch the LABEL button.
- 3 Touch any CHANNEL PRESET button. (Use the ARROW buttons to view more Presets). The TouchPanel displays the Calculator Pad.
- 4 Enter the desired label with the Calculator Pad. (any combination of letters or numbers, up to 8 characters long).
- 5 When you are done, touch the check-mark to return to the TV screen.

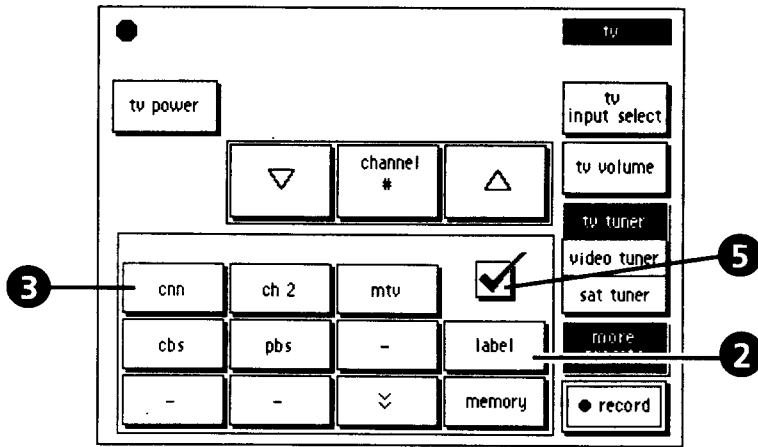

Using a cable or satellite tuner

You can use the cable or satellite screens to select a cable or satellite TV station, set up channel Presets, or begin recording from a cable or satellite tuner.

To get to the CABLE/SATELLITE screen, touch these buttons:

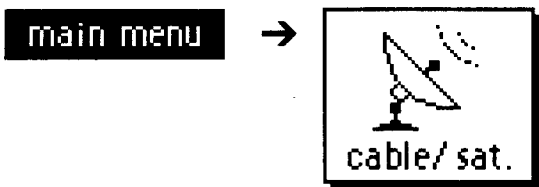

The Satellite screen

The Cable screen is identical.

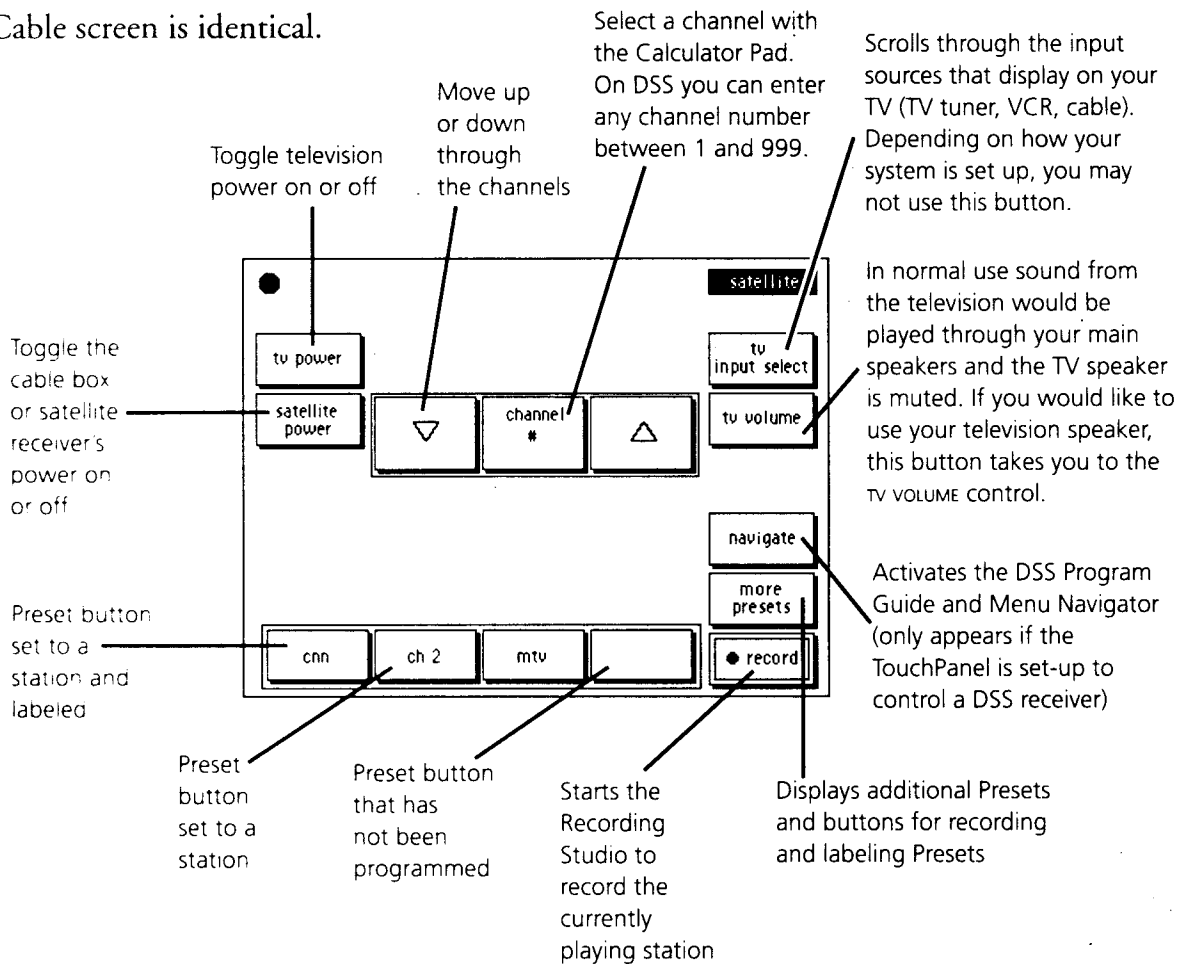

About presets

The channel presets that appear on the cable or satellite screens will be the same ones that you have set for your TV and VCR. To preset stations for your satellite system, use your DSS receiver's Favorite Channel List function or your satellite receiver's Preset Station Setting function.

Using the DSS program guide navigator screen

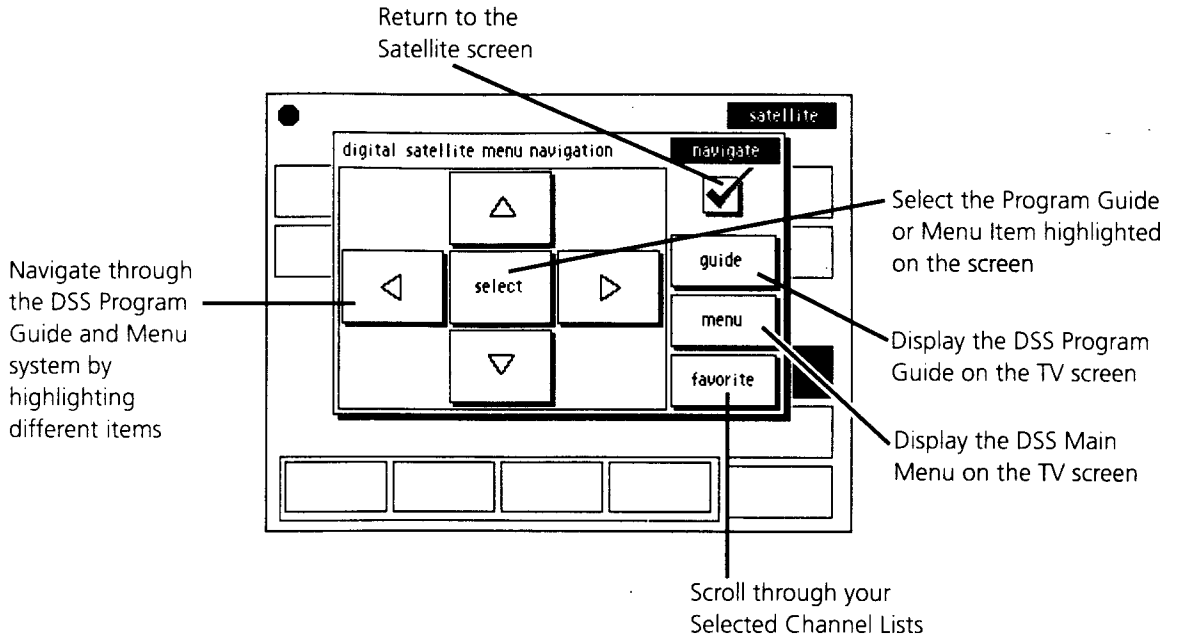

Using a VCR

You can use the Video screens (one for each of the VCRs you have connected) to play tapes or start recording from a tape.

To get to a Video screen, touch one of the video buttons:

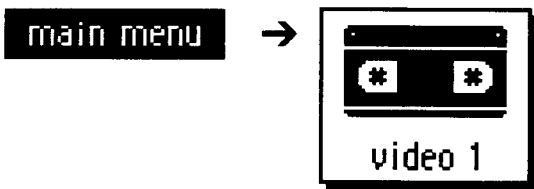

The VCR screen

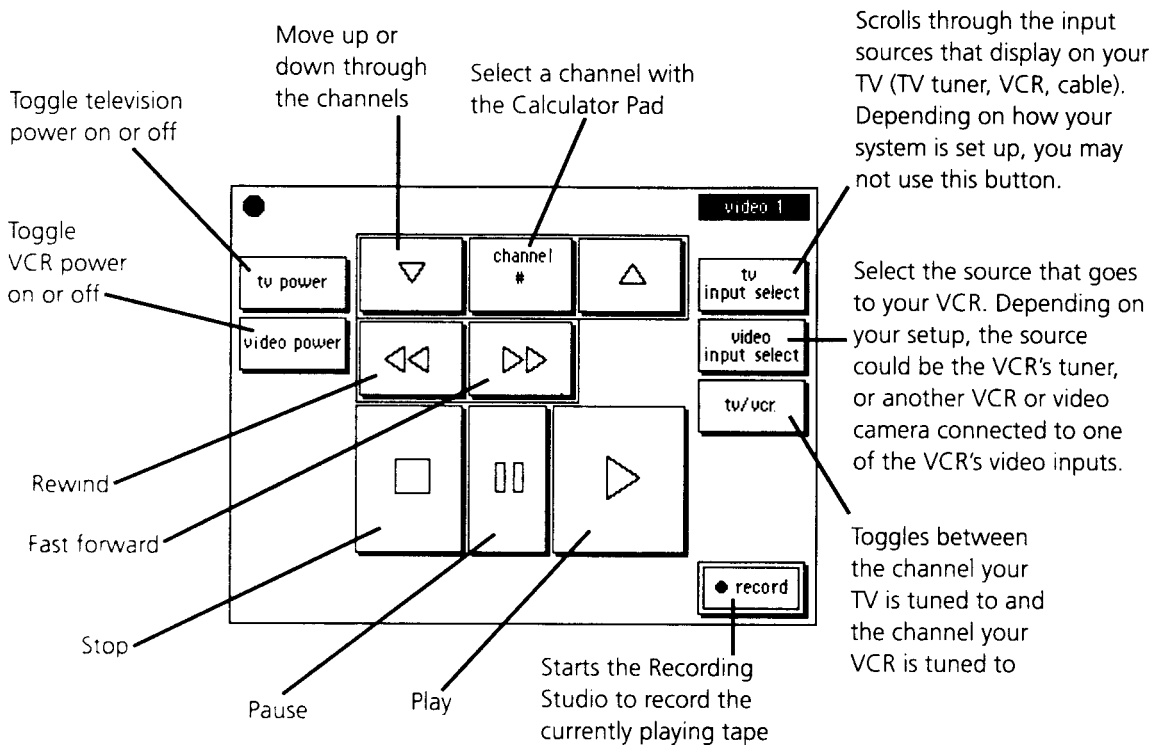

About recording

For instructions on recording to a VCR, see 'Recording' on page 49.

Using a laserdisc player

You can use the Laserdisc screen to play laserdiscs or start recording from a laserdisc.

To get to the Laserdisc screen, touch these buttons:

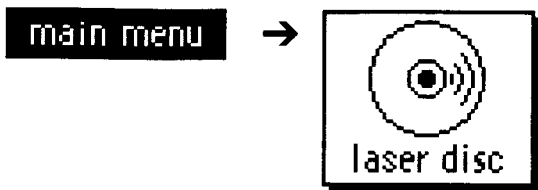

The Laser Disc screen

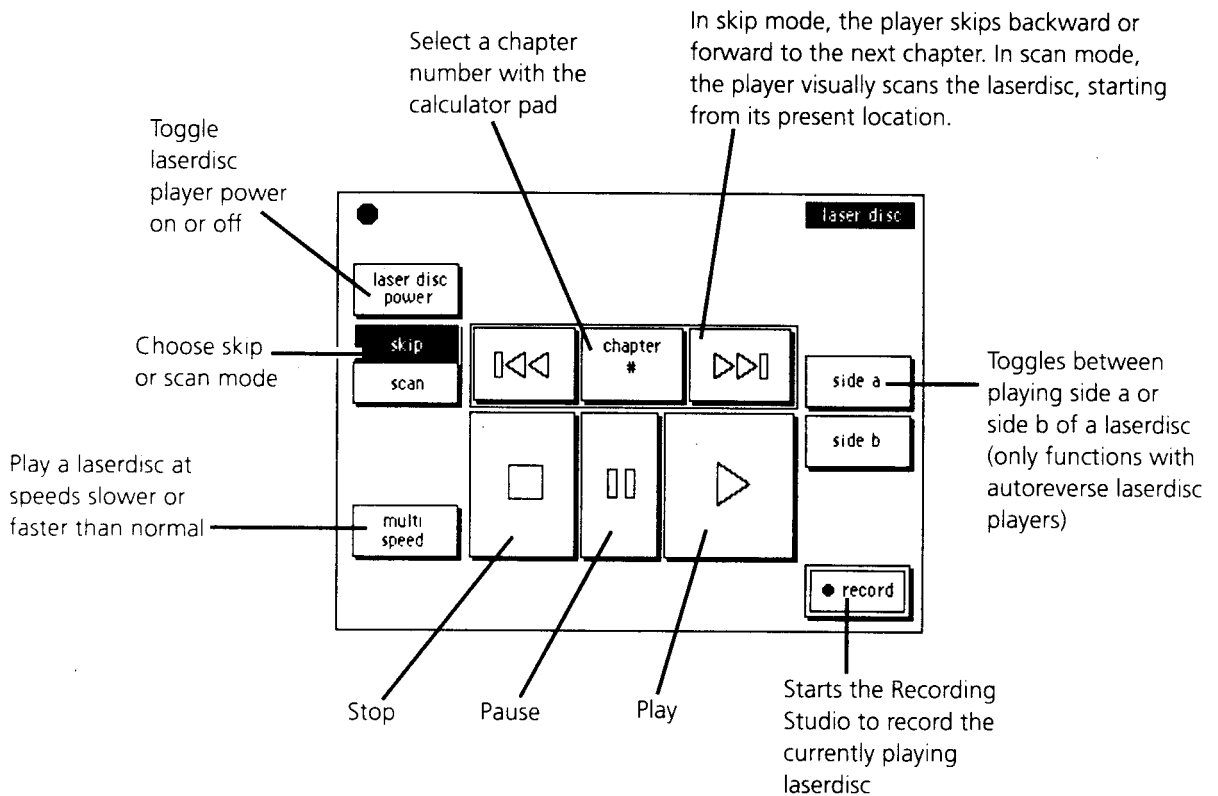

Using the laserdisc multi-speed modes

To use the multi-speed modes, you'll need either a special laser disc (one recorded in the CAV format) or a special laser disc player (one that supports digital special effects).

In the multi-speed mode, the player visually scans the laserdisc, starting from its present location. In frame advance mode, the player skips backward or forward one frame at a time for each touch.

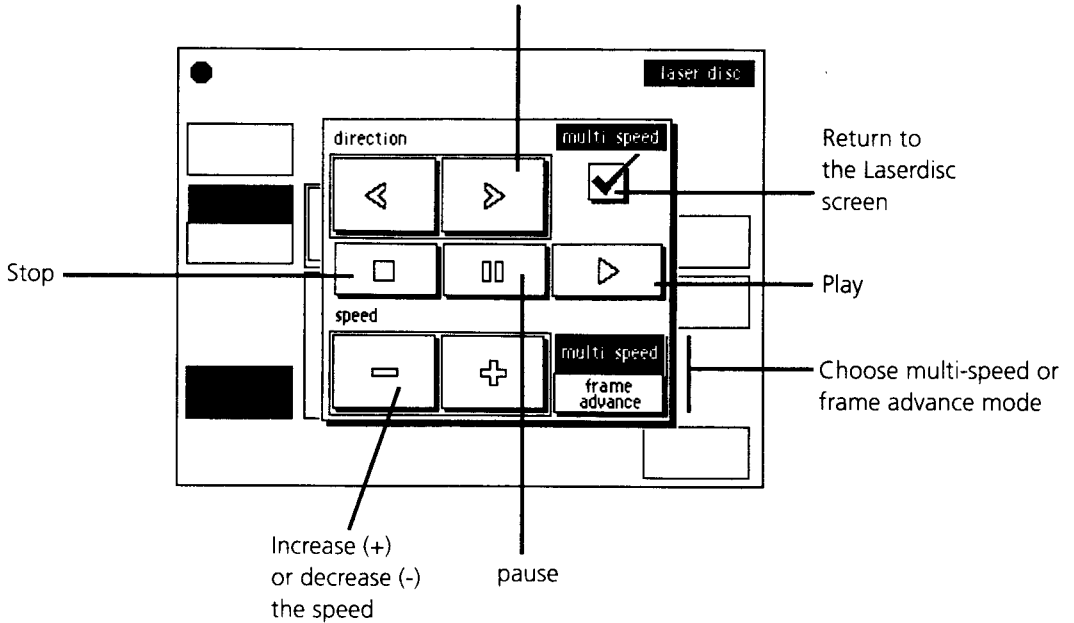

Using a DVD player

You can use the DVD screen to play DVDs or start recording from a DVD.

To get to the DVD screen, touch these buttons:



The DVD screen

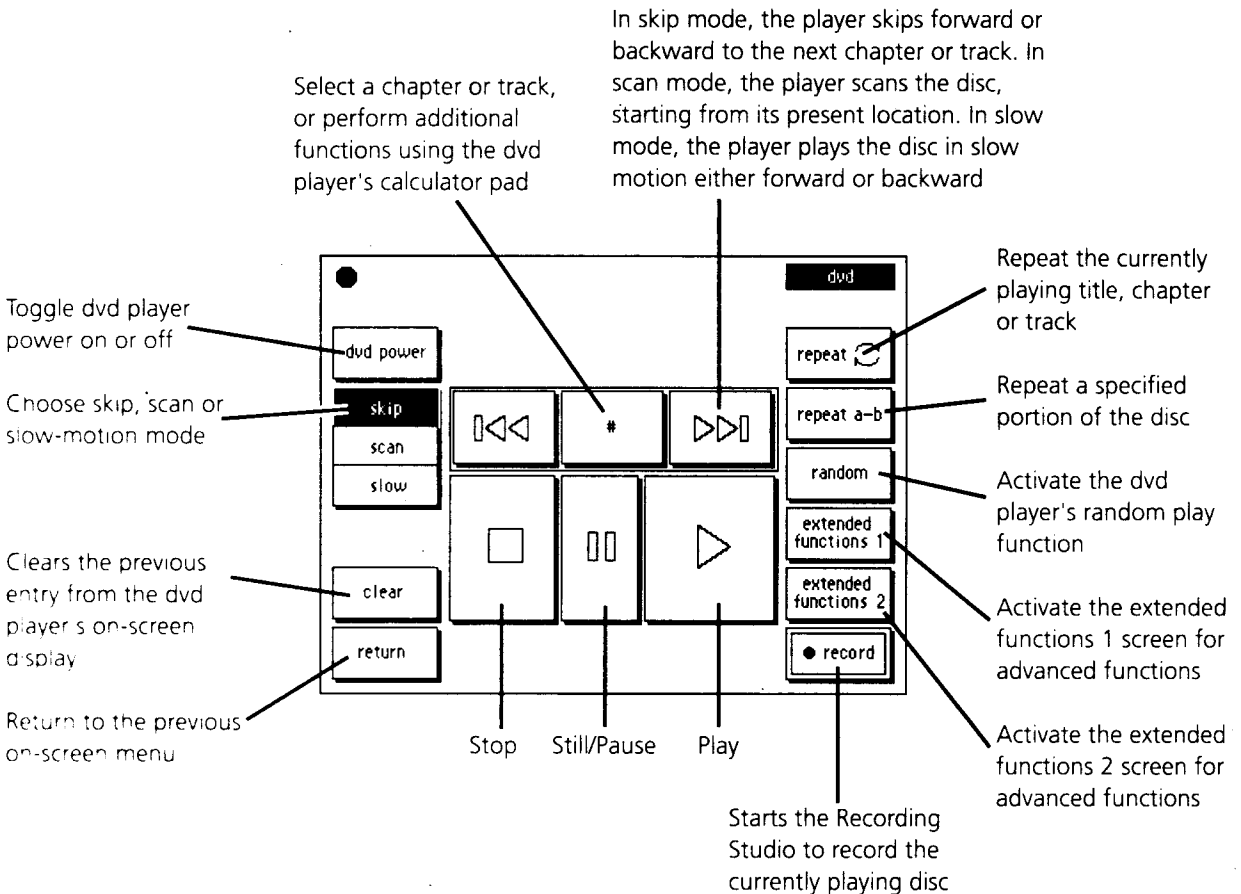

Using a DVD player's advanced features

You can use the TouchPanel to control many of a DVD player's more advanced functions and features.

NOTE: Some of these features may or may not work depending on the particular DVD player you are using and the particular DVD disc you are playing. Check your DVD player's owner's manual and the DVD disc's packaging for further information.

The Extended Functions 1 screen

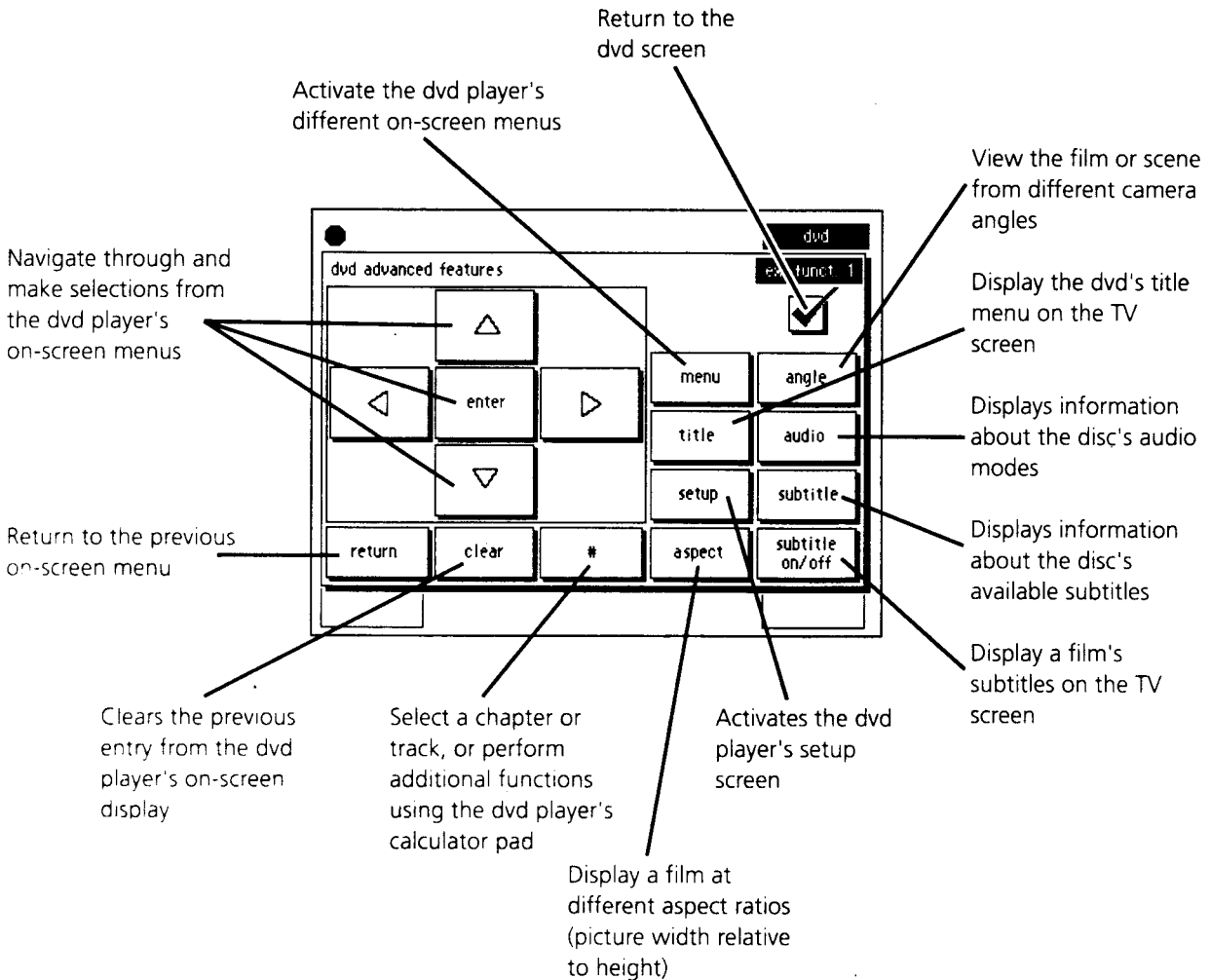

The Extended Functions 2 screen

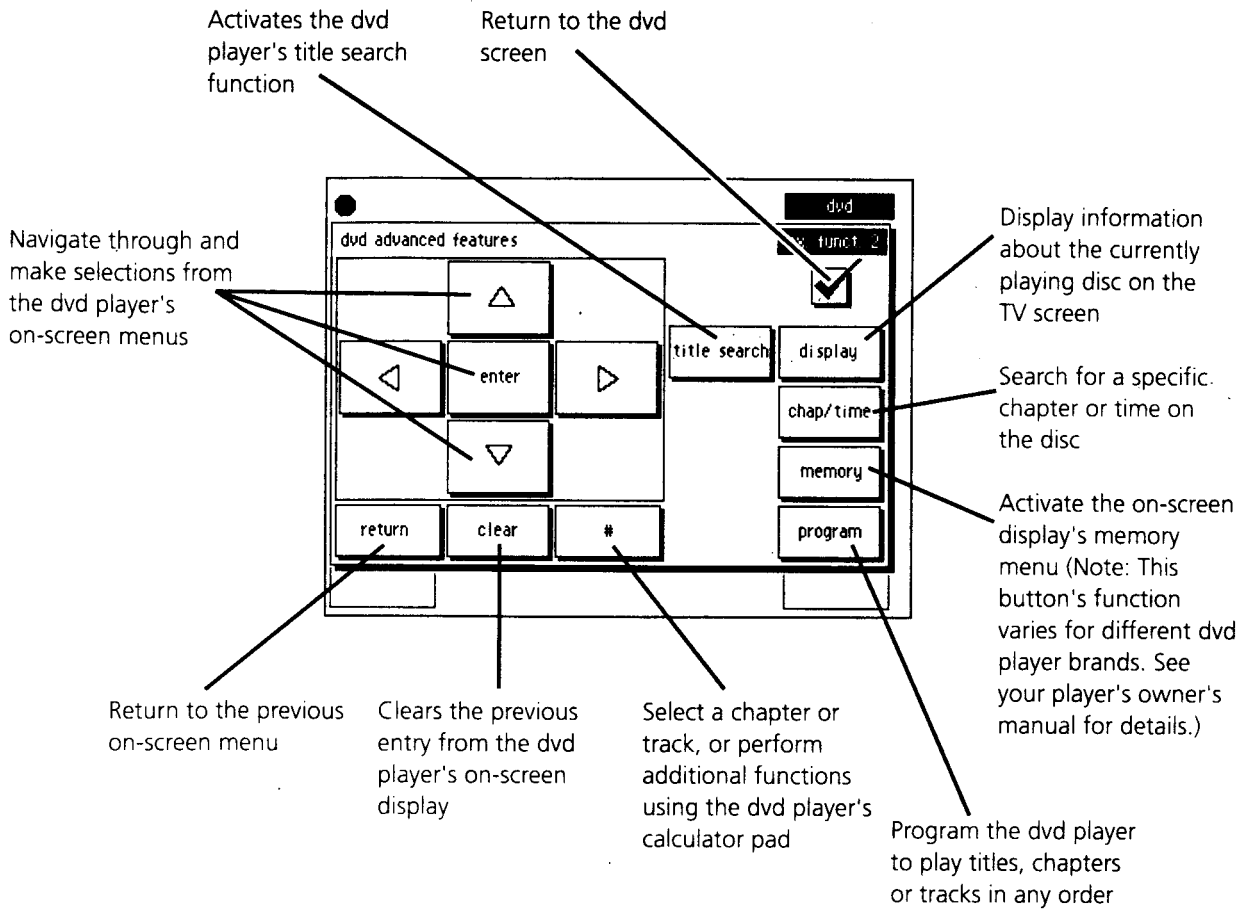

The DVD calculator pad

The calculator pad works a little differently for DVD than it does for other sources. (Most DVD players use the calculator pad to access different features in addition to entering chapter and track numbers.) Check your DVD's user manual for information about using the calculator pad to access different features and functions.

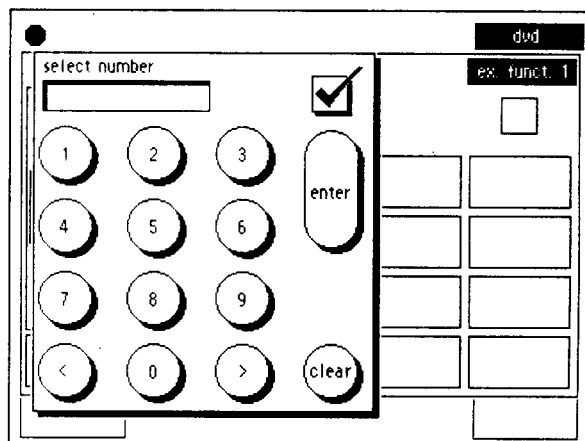

Adjusting sound

To view or change the current settings, touch the **SOUND** button when you're using any component. When you're finished making changes, touching the **CHECK-MARK** will return you to the controls of the component you were using.

From the Sound menu you can:

- Select an audio mode: Source Direct, Stereo, Mono, Dolby 3 Stereo, Dolby Pro Logic, or Dolby Digital (AC-3).
- Add sound processing: THX Cinema (for more accurate film sound) and DSP Logic (for simulated room sound).
- Adjust Bass and Treble.
- Select Midnight mode for quiet listening.
- Control speaker delay and sound level.
- Reset sound settings to their default value.

Saving your settings

Any changes you make from the Sound menu, plus the settings for the current component, can be saved as a System Preset. See the chapter 'Using system presets' later in this booklet.

Accessing sound controls

To get to the Sound screen, touch this button:



The following sound controls are available:

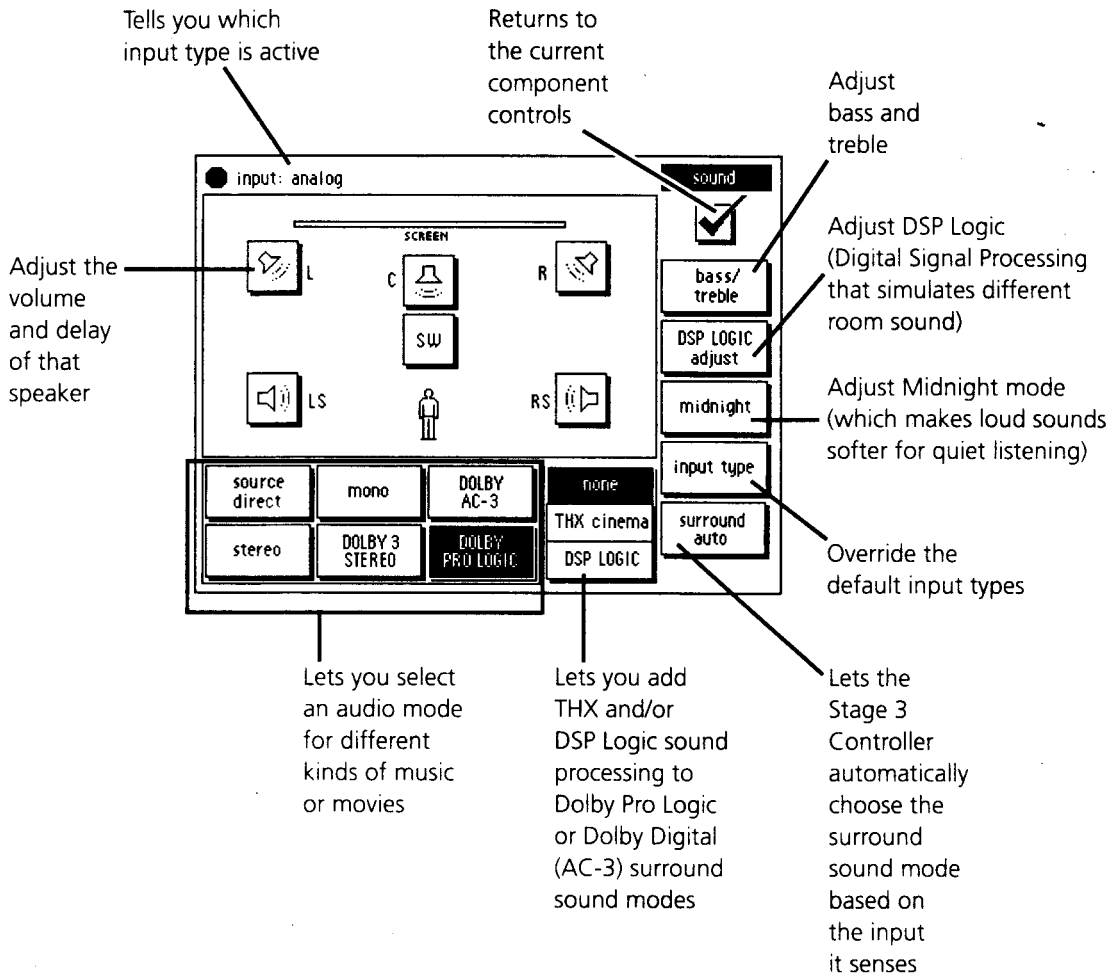

About Surround Auto

If SURROUND AUTO is ON, the Stage3 Controller will automatically choose the best input type from among those that are connected to the active source. The priority is: RF, Digital Coaxial, Digital Optical, Analog.

About the audio modes

You can choose from six audio modes, including three music modes (source direct, mono, and stereo) and three surround-sound modes (Dolby 3 Stereo, Dolby Surround Pro Logic, and Dolby Digital [AC-3]).

When you select an Audio Mode, the TouchPanel uses darkened icons to show you which speakers are producing sound in that mode (if your system includes a subwoofer it will remain active in all audio modes). For example, in Stereo mode, the left and right speaker icons will be darkened, and so will the subwoofer icon if you have a subwoofer installed. In Dolby Digital (AC-3) mode, the left, center, right, surround, and subwoofer speaker icons would be darkened.

Source Direct

Plays the audio source in stereo, bypassing all of the Stage 3 Controller's digital, surround, and tone control circuitry. This allows you to listen to a stereo recording in the purest possible way. (Source Direct operates only with components connected using the Stage 3 Controller's analog inputs).

Stereo

Plays the audio source in stereo using only the left and right speakers and applies any adjustments you've made on the Bass and Treble Menu.

Mono

Plays the audio source in monaural using only the center speaker only. If your system does not have a center speaker, the monaural sound will come through the left and right speakers.

Dolby 3 Stereo

Plays the audio source through the left, center and right speakers. For music, this retains a stereo sound, with improved imaging and definition, especially for multiple listeners. For home theater, this mode is only useful if you are not using surround speakers in your system.

Dolby Pro Logic

Plays the audio source through the left, center, right and surround speakers, using Dolby Pro Logic decoding for surround sound. This is the standard setting for Dolby Surround-encoded video tapes, laser discs, and TV broadcasts.

Dolby Digital (AC-3)

Plays the audio source through the left, center, right and surround speakers, using Dolby Digital (AC-3) decoding for surround sound. This is the setting to be used on DVDs and laser discs or other sources that are labeled 'Dolby Digital (AC-3)'.

Surround Auto

If the input is CD, mini disc, tuner, phono or tape, the Controller automatically selects stereo mode. If the input is TV, laser disc, cable/sattelite or video, the Controller selects Dolby Surround Pro Logic mode. If the source is recorded in Dolby Digital (AC-3), the Controller selects Dolby Digital (AC-3) mode. (You can still select any surround mode manually).

What you can change

The audio modes you can select depend on the speakers you have installed in your system.

If your system has

Left and Right speakers

Left, Center and Right speakers

Left, Right and Surround speakers

Left, Center, Right and Surround speakers

You can select

Source Direct, Stereo, Mono,
Dolby AC-3

Source Direct, Stereo, Mono,
Dolby 3 Stereo, Dolby AC-3

Source Direct, Stereo, Mono,
Dolby Surround Pro Logic, Dolby AC-3

Source Direct, Stereo, Mono, Dolby 3
Stereo, Dolby Surround Pro Logic,
Dolby AC-3

NOTE: Dolby Digital (AC-3) sources will play with any speaker configuration. If your system lacks surround or center speakers, the Stage 3 Controller will blend the information for those channels into the left and right speakers.

Adding sound processing

The Stage 3 Controller offers 3 choices for sound processing: THX Cinema, DSP Logic, and none:

THX Cinema

Because a film's soundtrack is meant to be heard in a large theater with dozens of speakers, movies can sound much different when played in a typical room at home. THX Cinema sound processing is special circuitry developed by Lucasfilm, LTD, that corrects this problem. THX Cinema adjusts tone, compensates for how our ears hear directional sound, and creates a more spacious, enveloping surround-sound environment. The result is sound that matches as closely as possible the sound created by the movie's director and sound technicians.

Keep in mind these points about THX Cinema processing:

- THX Cinema processing can only adjust sound that has already been decoded by a surround-sound decoder, and so it is only available when the Controller is in Dolby Digital (AC-3) or Dolby Surround Pro Logic mode.
- Use THX Cinema processing for films marked Dolby Digital (AC-3), Dolby Surround, or Dolby Stereo (a term used to denote Dolby Surround that you may find on older laserdiscs and videotapes).
- Activating the THX Cinema mode automatically resets the bass and treble controls to their flat settings. Once you activate THX Cinema mode, you can boost or cut the bass and treble settings as you like. When you exit THX Cinema mode, the bass and treble settings will return to the values they were at before you selected THX Cinema.

DSP Logic

Combines the surround sound of Dolby Digital (Dolby AC-3) and Dolby Surround Pro Logic with proprietary Kenwood Digital Signal Processing. This lets you personalize the listening environment to simulate the way films (or music) would sound in different rooms, from the intimate environment of a jazz club to the spaciousness of a large theater.

- You can use DSP Logic processing for any Dolby Digital (AC-3), Dolby Surround or stereo music programs.
- DSP Logic processing is only available in the Dolby Digital (AC-3) and Dolby Surround Pro Logic modes.

For instructions on how to adjust the DSP Logic settings, see 'Adjusting DSP Logic' on page 45.

None

Turns off both THX Cinema and DSP Logic processing.

Adjusting bass and treble

To get to the Bass/Treble Adjust screen, touch these buttons:

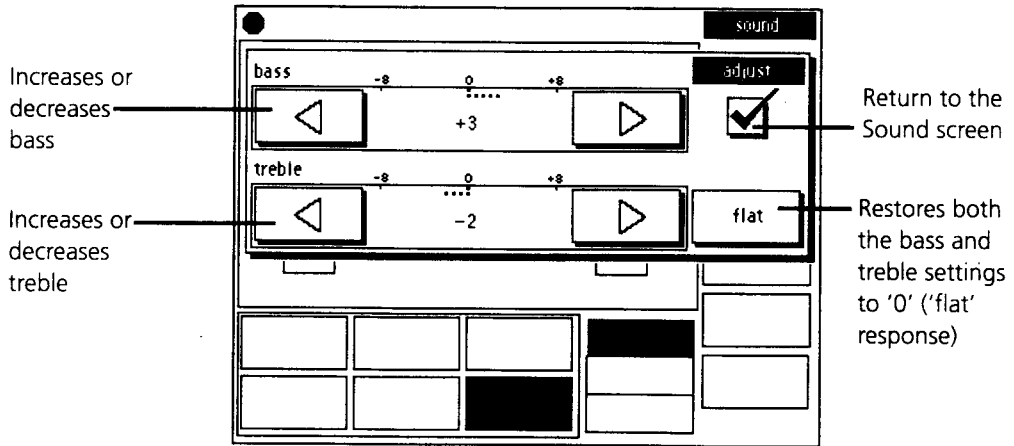

Any changes you make on this screen are erased (and the settings reset to '0') when you:

- Change input sources
- Activate the Surround Auto mode
- Put the Controller in Standby mode (shut-down the system)

You can save changes in bass and treble level as part of a System Preset.

Adjusting DSP Logic

To get to the DSP LOGIC screen, touch these buttons:



- 1 Touch the WALL button. You can select from 3 different wall textures. SOFT makes the simulated walls absorb more sound (such as in a room full of people), while HARD makes them reflect more sound (like a theater that's nearly empty).
- 2 Touch the ROOM SIZE button. You can select from 3 different room sizes. The sizes refer to public spaces, so SMALL might be used to simulate a more intimate club, while LARGE could be used to simulate a large theater.
- 3 Touch the EFFECT LEVEL button. You can change the effect level from 1 (very little effect) to 5 (maximum effect).
- 4 When you are done, touch the CHECK-MARK to return to the Setup screen.

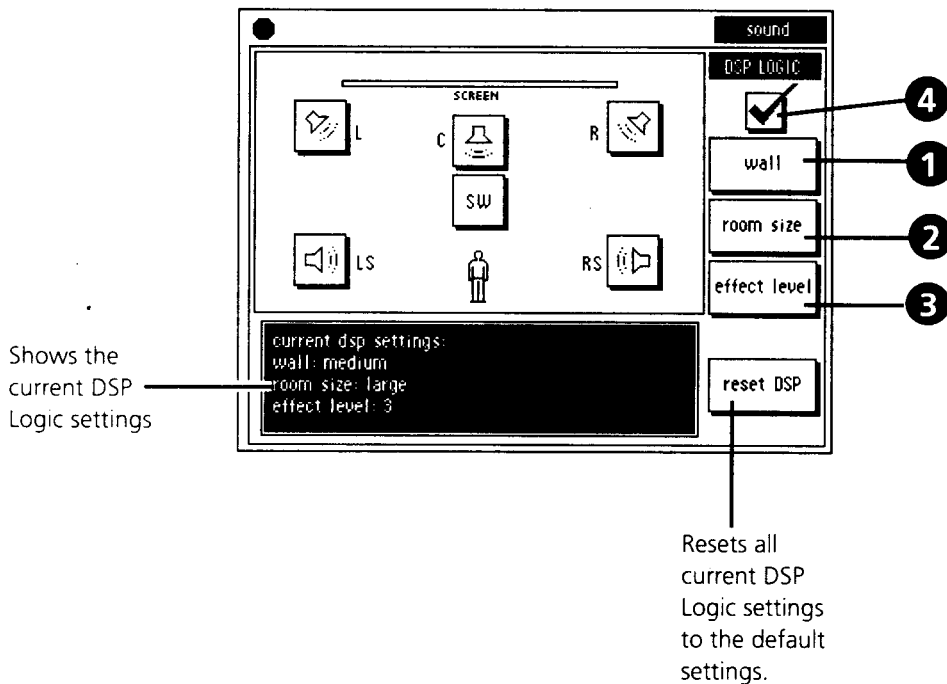

Adjusting for quiet listening

Midnight mode dynamic range compression makes the quiet and loud parts of a movie or music closer to the same level. This lets you turn up the sound so you can hear the quiet parts without being surprised by a loud part.

NOTE: Midnight mode only works with Dolby Digital (AC-3) programs that have been specially encoded.

To get to the Midnight screen, touch these buttons:

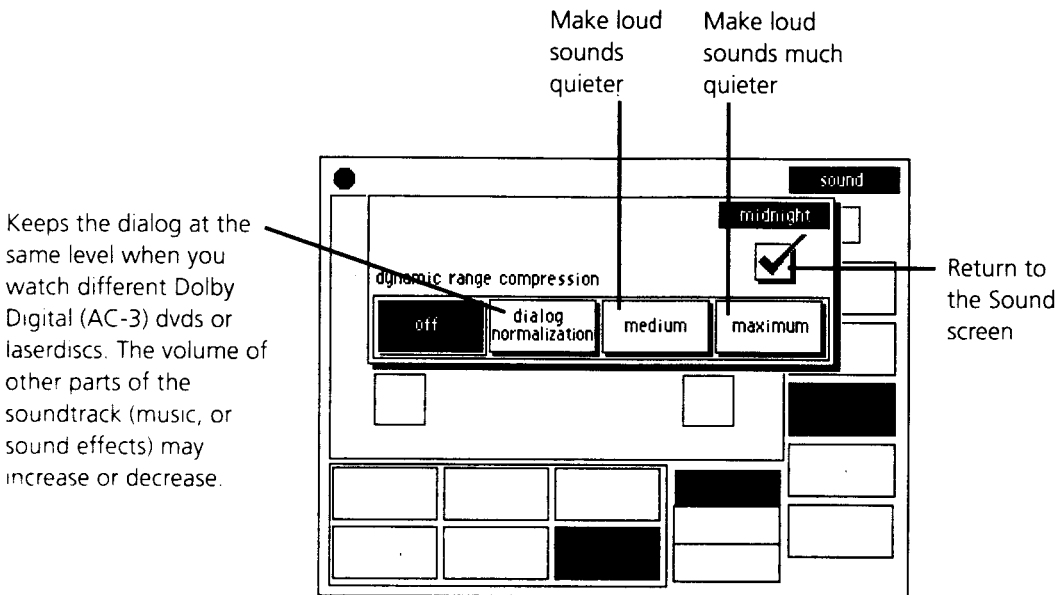

Adjusting speaker delay and level

When you set up your system, you set the default settings for Delay Time by setting the distance between all of your speakers. You can, if you want, change the delay time and level.

To get to the Speaker screen, touch these buttons:



The screenshot shows a screen titled "center speaker settings:" with a "speaker" checkbox checked. It features two sliders: "channel level" (ranging from -12 to +12 dB) and "delay time" (ranging from 0 to 10 ms). Each slider has a "reset" button. Below the sliders are several small square buttons, some of which are highlighted in black. Annotations include: "The speaker you're changing" pointing to the top of the screen; "Each touch changes the speaker level by 1 dB (decibel)" pointing to the left arrow of the channel level slider; "Each touch changes the delay time by 1 ms (millisecond)" pointing to the left arrow of the delay time slider; "Return to the Sound screen" pointing to the speaker checkbox; "Resets the speaker settings to the default settings" pointing to the reset buttons; and "Before you make any changes, the default setting is displayed" pointing to the highlighted buttons at the bottom.

Any changes you make on this screen are erased (and the settings reset to their default settings) when you:

- Change input sources
- Activate the Surround Auto mode
- Put the Controller in Standby Mode (shut-down the system)

You can save changes in speaker level and delay time as part of a System Preset.

Selecting the audio input type

For normal use we suggest that you allow the Stage 3 Controller to select the optimum input type for you using the system's default settings.

If you are an expert user and would like to make input type changes the following input types are available, depending on the connections made to your source components:

- 1 Make sure you have turned off Surround Auto (see page 47).
- 2 If you are not on the Input Type screen, touch these buttons:



- 3 Depending on how you have connected your components, select from the following input types:
 - RF (for laserdisc players with Dolby Digital [AC-3] RF outputs)
 - Digital Coaxial (for CD players, laserdisc players, DVD players, mini disc recorders and satellite receivers with coaxial digital outputs)
 - Digital Optical (for CD players, laserdisc players, DVD players, mini disc recorders and satellite receivers with TOS-link optical digital outputs)
 - Analog (for all components that have standard RCA-type analog outputs).
- 4 Touch the CHECK-MARK to return to the Sound screen.

About Digital Recording

If you have activated the Digital Coaxial or Optical Input for a component, it cannot be used as a source for recording (except to make a digital recording onto a mini disc).

Recording

The Recording Studio function allows you to select a source component to record from, and a destination component to record onto, and lets you control them both from the TouchPanel.

General instructions for the Recording Studio

- 1 To activate the Record Studio, press the RECORD button in the lower right corner of almost any TouchPanel screen. The component you're listening to becomes the source component for the recording. The TouchPanel then displays the Record Studio screen.

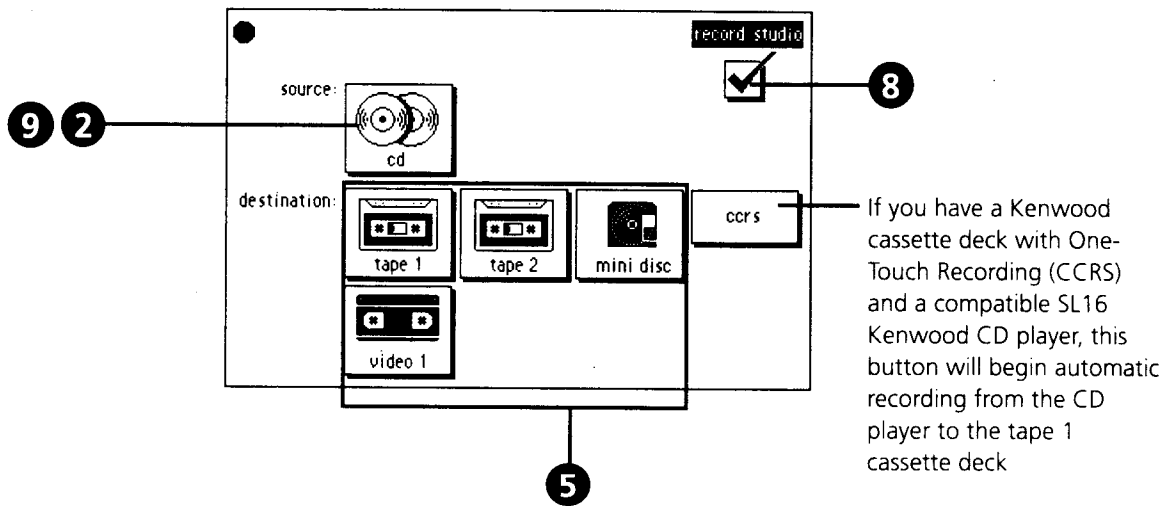

- 2 Touch the SOURCE COMPONENT icon on the Record Studio screen.
- 3 Prepare the source for recording by cueing up the selection you wish to record (the procedure for this will depend upon the specific component you have).
- 4 Touch the RECORD icon in the lower right corner of the source component's screen to return to the Record Studio screen.

- 5 Select the component you want to record onto by touching its destination icon.
- 6 Prepare the recorder for recording (set Dolby Noise Reduction, cue-up the tape, and so on)
- 7 Once the recorder is set up, put it into the RECORD mode (the procedure for this will depend upon the specific component you have).
- 8 Touch the CHECK-MARK key on the component's control screen to return to the Record Studio screen.
- 9 Touch the SOURCE COMPONENT icon.
- 10 Put the Source Component into the PLAY mode.

About the cassette deck recording controls

You can only record from a source component that is connected to the Stage 3 Controller's analog inputs. (See 'Selecting the audio input type' on page 48.)

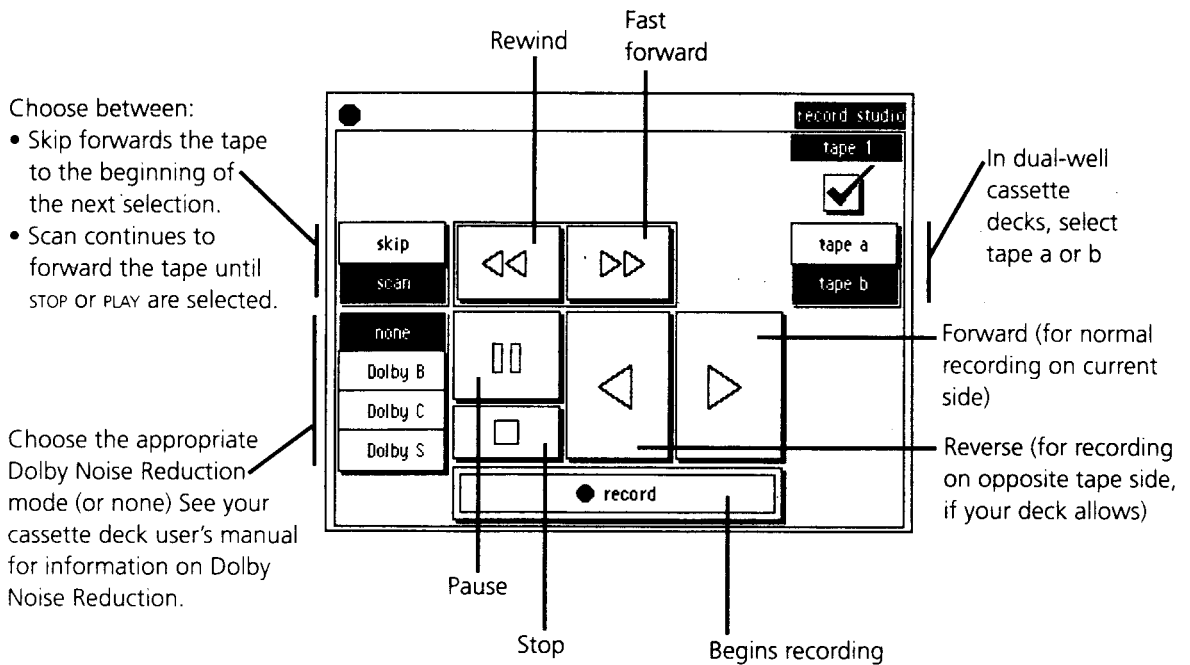

If you have a Kenwood SL16 cassette deck

Kenwood SL16 cassette decks send information back to the TouchPanel. This means you'll see more information displayed if you're using one of these decks:

- The TouchPanel's STOP, PAUSE, PLAY, FAST FORWARD and REVERSE (skip and normal mode) buttons will remain darkened when they're in use (instead of just momentarily turning dark), letting you know which mode is currently active.

About the Mini-Disc recording controls

If the source is connected to the Stage 3 Controller's digital inputs, you can record using the mini-disc recorder's digital inputs. If the source is connected to the Stage 3 Controller's analog inputs, you can record using the mini-disc recorder's analog inputs.

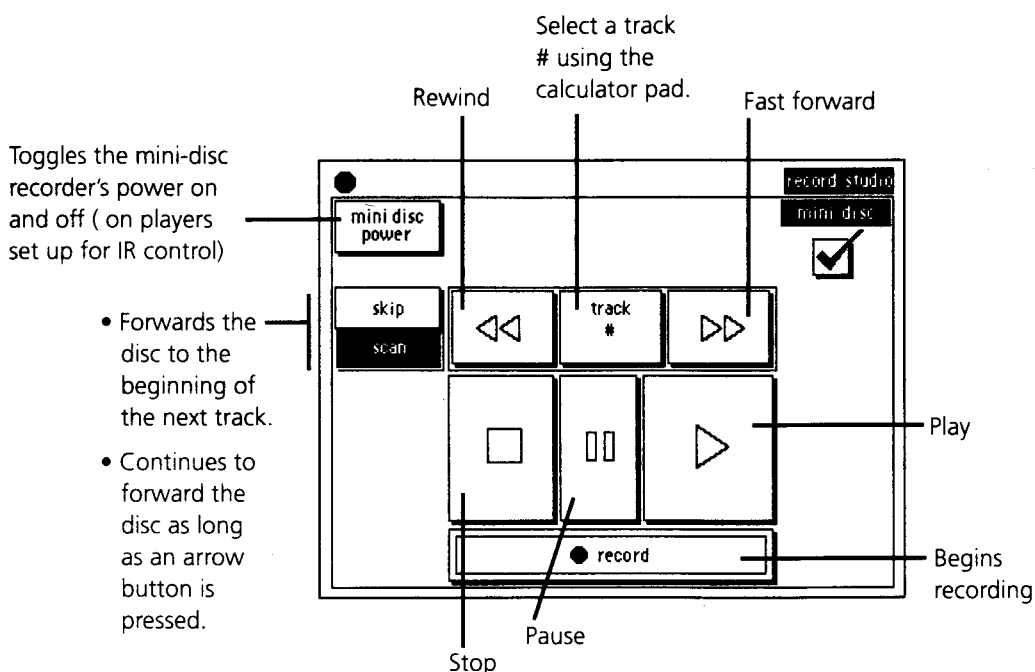

If you have a Kenwood SL16 mini-disc recorder

Kenwood SL16 mini-disc players send information back to the TouchPanel. This means you'll see more information displayed if you're using one of these players.

- The TouchPanel's TRACK button will display the currently playing track number.
- The TouchPanel's STOP, PAUSE, PLAY, FAST FORWARD and REVERSE (SKIP and NORMAL mode) buttons will remain darkened when they're in use (instead of just momentarily turning dark), letting you know which mode is currently active.

About the VCR recording controls

You can record from any source connected to the Stage 3 Controller's analog inputs, or from the VCR's built-in tuner, or from any video components connected directly to the VCR itself (not through the Stage 3 Controller). Two video inputs with record capability are available on the Stage 3 Controller. If both are set-up, each would have its own button on the Recording Studio menu. (See 'General instructions for the recording studio' on page 49.)

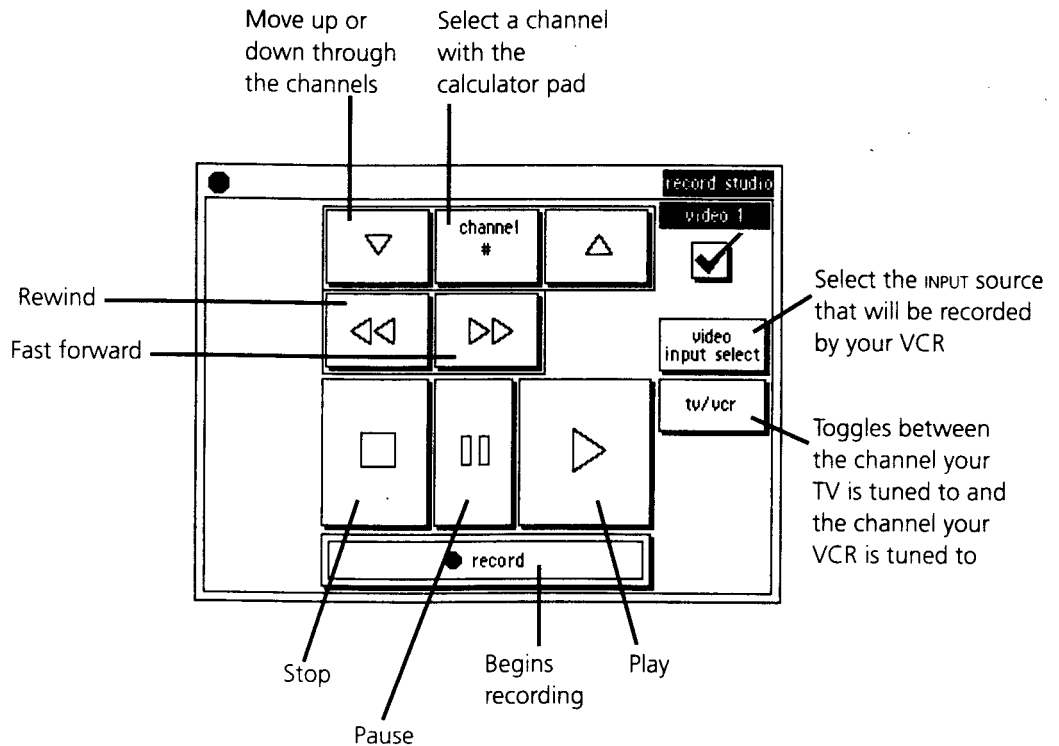

Creating system presets

System presets are a powerful part of the Stage 3 Controller system. Although a System Preset is similar to a radio preset that recalls a single radio station, a System Preset can recall several settings at once, or can even reconfigure your entire system. For example, family members can adjust the system to their taste, save the settings as a preset, and then later restore the settings by touching one button.

You can create and store up to 6 different System Presets.

You can use a Preset to carry out several commands to prepare for a particular listening or viewing experience. A single System Preset can perform all of the following tasks:

- Turn the Stage 3 Controller's power on
- Change the input type
- Change the volume of each speaker
- Change the delay time of each speaker
- Change all of the DSP Logic settings
- Change the Midnight Mode's dynamic range compression settings
- Activate any of the Surround modes (stereo, Dolby Surround Pro Logic, and so on)
- Activate THX Cinema or DSP Logic processing
- Change the bass and treble settings
- Select the Source Input
- If the source component is a VCR, laserdisc player, DVD player, CD player, cassette deck or MD recorder, start the Play mode
- If the source is tuner, change the radio station being received.

The Stage 3 Controller stores all of these settings in memory. When you activate that preset, the controller restores all of these settings. You can create another preset with different settings simply by changing the settings and memorizing another preset.

Creating or changing a system preset

1 To get to the System Presets screen, touch these buttons:

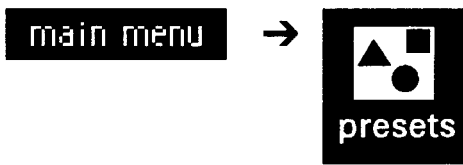

- 2 Select a source component from the Main Menu. If you select video, laserdisc, DVD, CD, tape or MD, it will automatically be put into play when the preset is activated. If you select tuner, the station playing when you memorize the preset will be selected when the preset is activated (even if the station is not a preset).
- 3 Go to the Sound screen and make any changes you wish to save in the preset (for example, treble and bass adjustments, speaker level adjustments, or selecting a surround sound mode such as Dolby Pro Logic).
- 4 Touch the MEMORY button, the Stage 3 Controller memorizes the source component and sound settings.
- 5 Touch a SYSTEM PRESET button to save the preset. If this preset was already programmed, the old preset information will be replaced with your new instructions.
- 6 Touch the CHECK-MARK to return to the Sound screen.

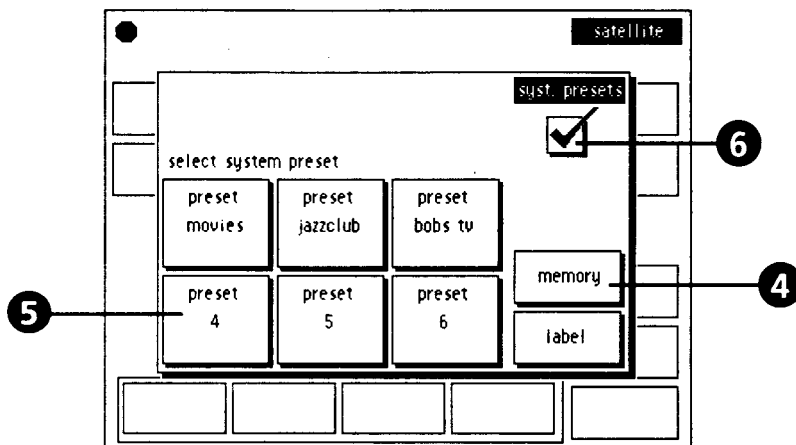

Playing a system preset

You can play a system preset in two different ways:

- Touch the PRESETS MENU button and then touch a PRESET button from the Preset Screen.
- Play the preset automatically by setting a preset alarm (see the chapter 'Setting the Alarm').

NOTE: If you touch a PRESET button after it has been activated, if the active source component is a VCR, laserdisc, DVD, CD, tape or MD, it will be put into the Pause mode.

Labeling a system preset

- 1 On the System Preset screen, touch the LABEL button.
- 2 Touch the system preset you would like to label. The TouchPanel displays the Calculator Pad.
- 3 Enter a number or name for your system preset with the Calculator Pad. Any combination of letters and numbers is fine, up to 8 characters
- 4 Touch the ENTER button to accept your label entry.
- 5 Touch the CHECK-MARK to apply the label and return to the Preset screen.

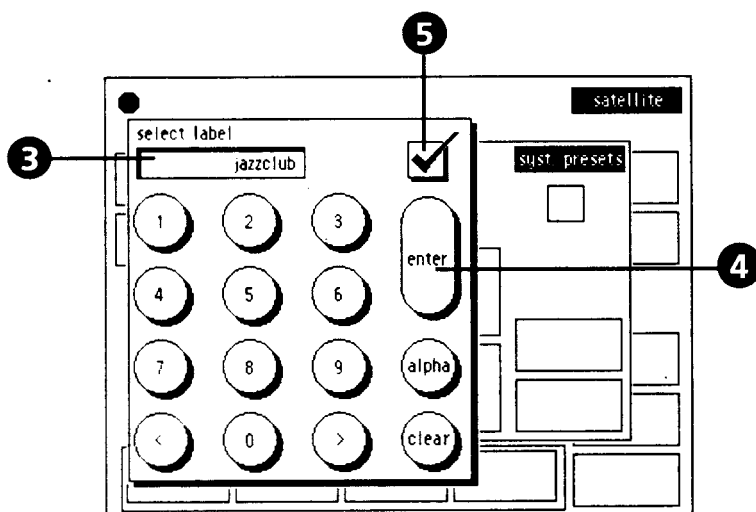

Setting a system preset alarm

You can have the TouchPanel automatically activate a system preset at a specific time every day.

- 1 To get to the the Alarm Set screen, touch these buttons:

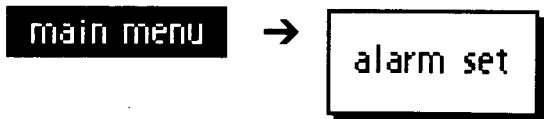

- 2 To set the hour, touch the HOUR button, then use the ARROW buttons to increase or decrease the time.
- 3 To set the minutes, touch the MINUTES button, then use the arrow buttons to increase or decrease the time.
- 4 Select a SYSTEM PRESET button. The System Preset will be activated at the time you set.
- 5 Touch the CHECK-MARK to exit.

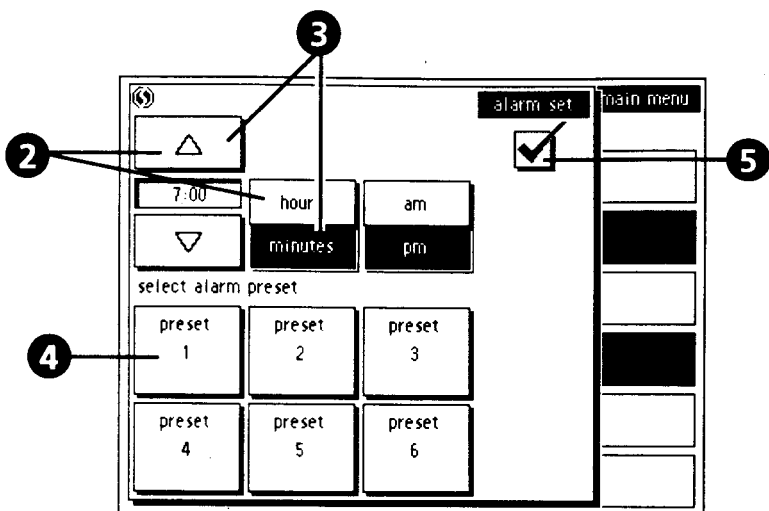

Controlling accessories

The Stage 3 Controller can activate up to 36 non-audio accessories (divided into 6 groups) that can be controlled using home automation equipment (such as the JDS Stargate system) that is capable of learning IR codes. The learned IR codes allow the accessory to be activated using the TouchPanel. (Touching the accessory's button sends its code out through the controller's IR repeater.)

Check the owner's manual for your home automation system for specific information about programming the TouchPanel's accessory IR codes into the home automation system.

To get to the Accessories screen, touch these buttons:

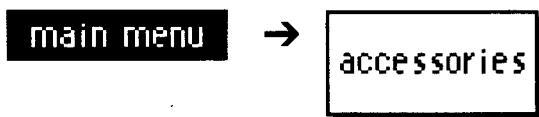

- 1 Touch one of the buttons to get to one of the accessory groups.

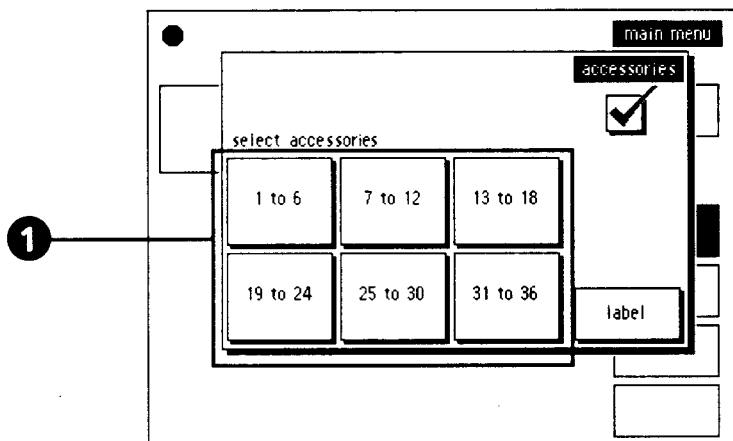

The TouchPanel will display that group's accessories screen:

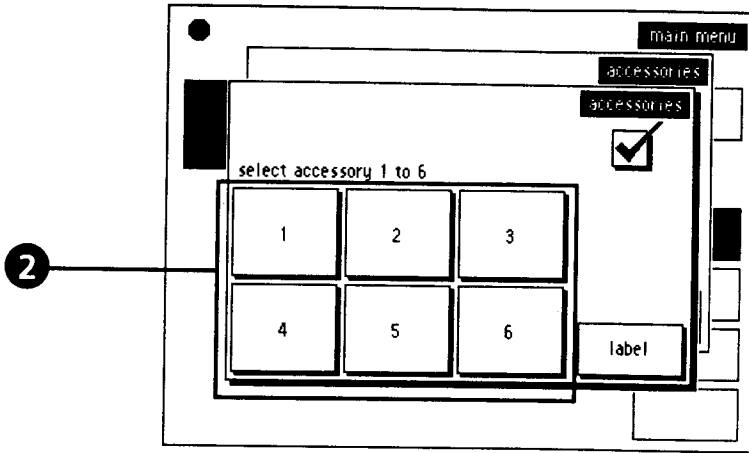

2 Touch one of the individual accessory buttons to activate that accessory.

Grouping and labeling accessories

Combining similar accessories into groups and labeling them can make it easier to operate your home automation system.

For example, home theater accessories, lights and home security accessories can be individually grouped and labeled on the ACCESSORIES screen:

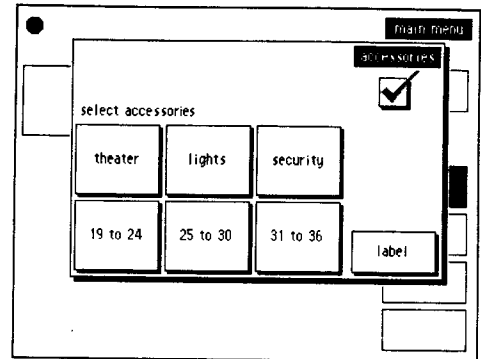

And the individual accessory buttons in each group can be labeled (such as in the THEATER group):

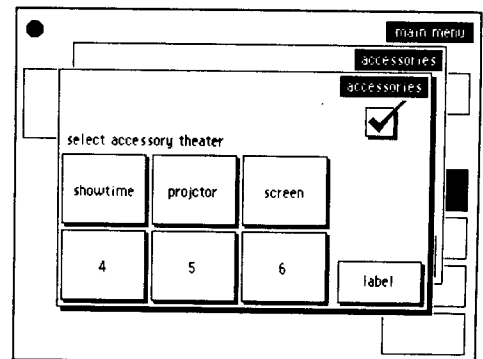

Setting the analog input level

Setting the proper input level eliminates distortion that occurs if an audio component's output level is too high. When this happens, the Input Overload Indicator on the Controller will flash red continually or remain red for 1 second or longer, letting you know you should decrease the input level for this component. (Occasional brief flashing red of the input overload indicator is OK).

If you're listening to a component and see that the Input Overload Indicator is flashing red too much or remaining lit, take these steps:

- 1 To get to the Input Level screen, touch these buttons:

main menu



setup



component



component icon

- 2 Touch the INCREASE ARROW button. Each touch changes the audio level by 2 dB. Adjust the input to the highest level you can without causing the Input Overload Indicator to flash red frequently or remain red for 1 second or longer.
- 3 Touch the CHECK-MARK to return to the Features screen.
- 4 Repeat this process for any component with an audio output that is too high.

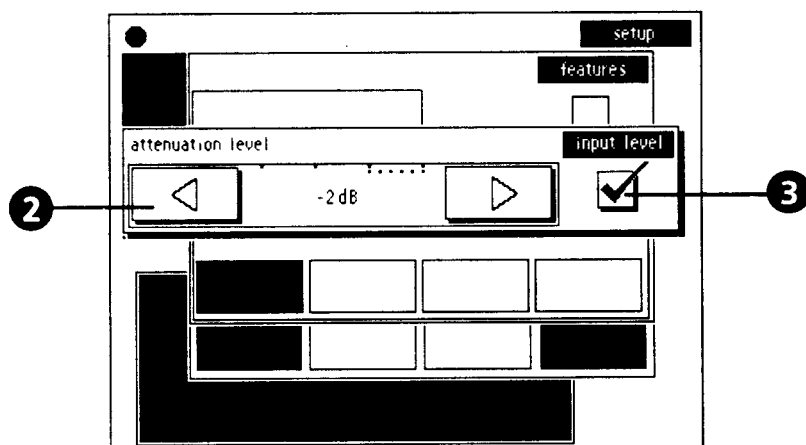

- Check that the individual speaker levels are set properly in the Sound Menu.
- Check that the Tape 2 Monitor has not been activated. (The Tape 2 Monitor icon on the Main Menu will be darkened if the circuit has been activated.)

No sound from one or more of the speakers, or the sound is abnormally low

- Check that all cables are connected properly.
- Check that all of the speakers in the system have been set up properly in the Setup (Sound) Menu (the Setup Sound screen will show a darkened icon for each speaker that has been activated).
- Check that the individual speaker levels are set properly in the Sound Menu.

No sound from the surround speakers and/or center speaker

- Check that either Dolby 3 Stereo, Dolby Pro Logic or Dolby Digital (AC-3) has been selected in the Sound Menu.

Sound only from center speaker when Dolby Pro Logic is selected

- Check that the program is in stereo (mono programs will play only through the center speaker in the Dolby Pro Logic mode).

No sound from the secondary speakers

- Check that the Remote Speaker Volume is properly set.
- Check that the source is connected via the analog inputs.
- Check that the analog input is selected on the Input Type selector.

No sound from certain laserdiscs

- Check that the disc contains a digital soundtrack (the disc's cover will bear a 'digital sound' logo). Some older laserdiscs contain only analog soundtracks. If the disc does not have a digital soundtrack, use the Input Type selector to change the input type to Analog.

No sound output to a video or audio tape deck during recording

- Check that the audio cables have been properly connected.
- Check that the source's Analog Input has been selected in the Sound Menu (digital inputs cannot be recorded from).

No video signal from the source component to the TV or recording VCR

- Check that the video source and TV are connected via the same type of connectors. (S-Video input signals are not sent out via the composite video output connections, and composite video input signals are not sent out via the S-Video output connections).

A hum when you select the PHONO input

- Check that the audio cables are plugged securely into the Phono jacks.
- Check that the turntable is grounded on the rear panel. The ground wire should be connected to the screw labeled 'Signal Gnd'.

With a Dolby Digital (AC-3) program, the loud sounds aren't very loud, and the quiet sounds aren't very quiet

- Check that the Midnight Dynamic Range Compression mode hasn't been activated.

Distortion in subwoofer

- Set Subwoofer Bass Limiter (see *Setting up your KC-Z1 Controller*).

The Bass Limiter is set at -24 and there is still audible distress from the subwoofer when listening at your usual volume levels

- If you're using a powered subwoofer, lower the volume on the subwoofer (or on the subwoofer power amplifier) until the distress disappears.
- Use the TouchPanel's Setup Sound menu and reduce the subwoofer's default channel level until the distress disappears.
- Reduce the TouchPanel Volume Control setting until the distress disappears (this will limit how loud you can listen to your system).
- Purchase a higher-quality subwoofer.

The ON/STANDBY indicator flashes red

- Turn the MAIN POWER switch OFF and ON again.
- Reset the Controller's microprocessor by unplugging the power cord from the AC outlet and plugging it back in with the MAIN POWER switch depressed and while holding-down the REMOTE POWER button. (NOTE: Resetting the Controller's microprocessor clears all of the stored defaults and setup data, returning the Controller and TouchPanel to their factory-shipped condition. You will have to reset the system, component, speaker and DSP Logic settings. See *Setting up your KC-Z1 Controller*.)

The Ref/Peak Level indicator flashes red continually, or stays red for more than 1 second

- Lower the analog input level for the source component you're listening to.
(see 'Setting the analog input level' on page 56)

The Ref/Peak Level indicator flashes green continually, or stays green for more than 1 second

- Do nothing. If the Ref/Peak Level flashes green, the source component output levels are normal, and there is no problem.

You can't receive radio stations

- Check that the station is tuned in properly.
- Check that the antenna is connected properly.

You can't receive a preset station by pressing the corresponding preset button

- Check that the preset station is a receivable frequency.
- Check that the preset memory hasn't been cleared because the power cord was unplugged a long time. If so, preset the station again.

Interference with reception

- Check for interference from electrical appliances by turning them OFF. If the interference goes away, leave the appliances OFF.
- Check for interference from the TV set by turning it OFF. If the interference goes away, leave the TV OFF, or move the antenna away from the TV.
- Check for interference from automobiles by moving the antenna as far away from roads as possible. If the interference goes away, permanently install the antenna away from roads.
- Check if the TouchPanel is set on top of the Controller or close to the antennas, and move it away (the fluorescent screen in the TouchPanel can interfere with AM reception).

You've forgotten your 4-digit security code

- Reset the TouchPanel's microprocessor by pressing the RESET button on its rear panel with a pointed object while holding-down the MUTE button.



Specifications

Preamp section

Total harmonic distortion:

All channels except for Subwoofer channel

0.003% (1 kHz, 1.0 volt)
0.003% (20 Hz to 20 kHz, 1.0 volt)

Subwoofer Channel

0.05% (31.5 Hz, 1.0 volt)

Frequency response

All inputs except for phono input 6 Hz to 100 kHz, +0 dB, -3 dB

Phono RIAA response

20 Hz to 20 kHz, ± 0.5 dB

Signal-to-noise ratio (IHF 1978):

All inputs except for phono input 101 dB

Phono input (MM)

87 dB

Input Sensitivity/impedance

All inputs except for phono input 200 mV/47 k-ohms

Phono input (MM)

2.5 mV/47 k-ohms

Tone Control

Bass ± 10 dB (100 Hz)

Treble ± 10 dB (10 kHz)

Output level/impedance

Surround: All channels except for Subwoofer channel

1.0 volt / 180 ohms (1 kHz, 0.003% THD)

Surround: Subwoofer channel

1.0 volt / 180 ohms (31.5 Hz, 0.003% THD)

Video section

Input level/impedance

Composite Signal: 1.0 volt peak-to-peak / 75 Ω

S-video: Luminance signal 1.0 volt peak-to-peak / 75 Ω

S-video: Chrominance signal 0.286 volt peak-to-peak / 75 Ω

Output level/impedance

Composite Signal: 1.0 volt peak-to-peak / 75 Ω

S-video: Luminance signal 1.0 volt peak-to-peak / 75 Ω

S-video: Chrominance signal 0.286 volt peak-to-peak / 75 Ω

Digital section

Sampling frequency

32 kHz, 44.1 kHz, 48 kHz

Input level/impedance

All inputs: Optical

-15 dBm to -21 dBm, 660 nm \pm 30 nm

All inputs: Coaxial

0.5 volt peak-to-peak / 75 Ω

Output level/impedance

All inputs: Optical

-15 dBm to -21 dBm, 660 nm \pm 30 nm

All inputs: Coaxial

0.5 volt peak-to-peak / 75 Ω

FM tuner section

Tuning frequency range

87.5 to 108 MHz

Useable sensitivity (Mono)

1.2 μ V (75 Ω) / 13.2 dBf

(75 kHz deviation, s/n 30 dB)

50 dB quieting sensitivity (Stereo)

32 μ V (75 Ω) / 41.2 dBf

(75 kHz deviation)

Total harmonic distortion (1 kHz)

Mono

0.6% (65.2 dBf input)

Stereo

0.7% (65.2 dBf input)

Signal-to-noise ratio (1 kHz, 75 kHz DEV.)

Mono

75 dB (65.2 dBf input)

Stereo

68 dB (65.2 dBf input)

Selectivity (\pm 400 kHz)

50 dB

Stereo Separation (1 kHz)

40 dB

Frequency response

30 Hz to 15 kHz, +0.5 dB, -3.0 dB

AM tuner section

Tuning frequency range

530 Hz to 1700 kHz

Useable sensitivity (30% modulation, s/n 20 dB)

16 μ V / (500 μ V/m)

Total harmonic distortion

0.7%

Signal-to-noise ratio (30% modulation, 1 mV input)

45 dB

Selectivity

30 dB

General

Power consumption

90 W

AC outlet (switched)

3 (total 200 W max.)

Dimensions:

Width

17-5/16" (440 mm)

Height

6-1/4" (159 mm)

Depth

17-5/16" (440 mm) without TouchPanel

Weight (net)

26.9 lb (12.2 kg)

Kenwood continually tries to improve its products, so specifications may change without notice.