

KENWOOD

AUDIO VIDEO SURROUND RECEIVER

KR-V8080

KR-V7080

INSTRUCTION MANUAL

KENWOOD CORPORATION

*This manual contains instructions for two models.
Model availability and features (functions) may differ depending on country and
sales area.*

Before applying power

Caution : Read this page carefully to ensure safe operation.

KR-VB080/KR-V7080 (En)

2 Before applying power

Units are designed for operation as follows.

U.S.A. and Canada AC 120 V only
Australia AC 240 V only

Europe and U.K. AC 230 V only
China AC 220 V only
*Other countries AC 110-120/220/230-240 V switchable

*AC voltage selection

The AC voltage selector switch on the rear panel is set to the voltage that prevails in the area to which the unit is shipped. Before connecting the power cord to your AC outlet, make sure that the setting position of this switch matches your line voltage. If not, it must be set to your voltage in accordance with the following direction.

Note:

Our warranty does not cover damage caused by excessive line voltage due to improper setting of the AC voltage selector switch.



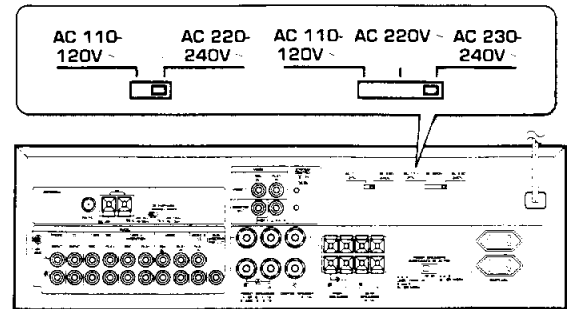

AC voltage selector switch



Move switch lever to match your line voltage with a small screwdriver or other pointed tool.

Safety precautions

WARNING : TO PREVENT FIRE OR ELECTRIC SHOCK, DO NOT EXPOSE THIS APPLIANCE TO RAIN OR MOISTURE.

 	CAUTION RISK OF ELECTRIC SHOCK DO NOT OPEN	CAUTION: TO REDUCE THE RISK OF ELECTRIC SHOCK, DO NOT REMOVE COVER (OR BACK). NO USER-SERVICEABLE PARTS INSIDE, REFER SERVICING TO QUALIFIED SERVICE PERSONNEL.
		THE LIGHTNING FLASH WITH ARROWHEAD SYMBOL, WITHIN AN EQUILATERAL TRIANGLE, IS INTENDED TO ALERT THE USER TO THE PRESENCE OF UNINSULATED "DANGEROUS VOLTAGE" WITHIN THE PRODUCT'S ENCLOSURE THAT MAY BE OF SUFFICIENT MAGNITUDE TO CONSTITUTE A RISK OF ELECTRIC SHOCK TO PERSONS.
		THE EXCLAMATION POINT WITHIN AN EQUILATERAL TRIANGLE IS INTENDED TO ALERT THE USER TO THE PRESENCE OF IMPORTANT OPERATING AND MAINTENANCE (SERVICING) INSTRUCTIONS IN THE LITERATURE ACCOMPANYING THE APPLIANCE.

Unpacking

Unpack the unit carefully and make sure that all accessories are put aside so they will not be lost. Examine the unit for any possibility of shipping damage. If your unit is damaged or fails to operate, notify your dealer immediately. If your unit was shipped to you directly, notify the shipping company without delay. Only the consignee (the person or company receiving the unit) can file a claim against the carrier for shipping damage. We recommend that you retain the original carton and packing materials for use should you transport or ship the unit in the future.

Accessories

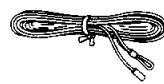
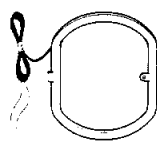
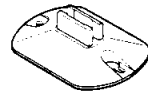
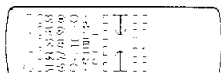
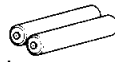
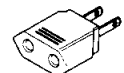
FM indoor antenna (1) 	AM loop antenna (1) 	Loop antenna stand (1) 
Remote control unit (1) 	Batteries (R6/AA) (2) 	* AC plug adaptor (1)  * Use to adapt the plug on the power cord to the shape of the wall outlet. (Accessory only for regions where use is necessary.)

Special features

DOLBY PRO LOGIC & DOLBY 3 STEREO

The surround system reproduces video software programs carrying the  mark with similar acoustic effects to movie theaters.

The DOLBY PRO LOGIC mode controls the audio signals of the Front Left/Right, Center and Rear surround channels using the built-in directivity enhancer circuit to reproduce the feeling of sound motions very realistically.

The DOLBY 3 STEREO mode can reproduce the motions of sound even when only the front and center speakers are used, by providing proper acoustic position using the directivity enhancer circuit.

DSP LOGIC & DSP presence

The DSP LOGIC mode adds presence sound components obtained from the DSP (Digital Signal Processor) to the signals output from the DOLBY PRO LOGIC (Left, Center, Right and Surround channels), allowing movie software programs to be played with a similar feeling of presence to movie theaters in a listening room in home.

The DSP presence mode adds presence sound components obtained from the DSP to the original source signals, allowing music source entertainment with the feeling of presence in an arena, stadium or jazz club in a listening room at home.



MACRO PLAY & PRESET REMOTE CONTROL

Complicated preparations of the video components including the monitor TV are required before playing video software. The convenient MACRO PLAY function is capable of storing the preparatory operation steps of these components in the remote control unit, so that simply pressing the MACRO key allows to prepare the video components making them ready for instant enjoyment. Also, the set-up codes of the video components can be preset in the remote control unit so that it can be used as a preset remote control unit for operating the desired video components.

Contents

Caution : Read the pages marked  carefully to ensure safe operation.

Before applying power

 Before applying power	2
 Safety precautions	2

Special features System connection

.....	3
.....	4
About the system control connections	5
FM DE-EMPHASIS/CHANNEL SPACE switch	8

Controls and indicators

Operation of remote control unit

Playing music

Sound adjustment functions

Recording

Broadcast reception

.....	9
.....	10
.....	12
.....	13
.....	16
.....	17
Receiving broadcast stations	17
Receiving radio stations by specifying its frequency	18
Storing radio stations in memory (Station preset)	19
Receiving a preset station	19
Receiving all preset stations in order	19

Operation of video components

Presence play

.....	20
.....	21
Adjustments for surround play	22
Surround play	24
Adjusting the surround effects (DSP LOGIC and DSP presence modes only)	25

Applied functions of the remote control unit

.....	26
How to preset the set-up codes	26
Remote controlling the video components	27

Automatic operation of several components (MACRO PLAY)

.....	28
Preparation for MACRO PLAY	28
Executing MACRO PLAY	29

Set-up code list

In case of difficulty

Specifications

.....	30
.....	36
.....	38

Connections of Audio and Video components

Make connection as shown below.
When connecting the related system components, refer also to the instruction manuals of the related components.
Do not plug in the power lead until all connections are completed.

Malfunition of microcomputer

If operation is not possible or erroneous display appears even though all connections have been made properly, reset the microcomputer referring to "In case of difficulty".

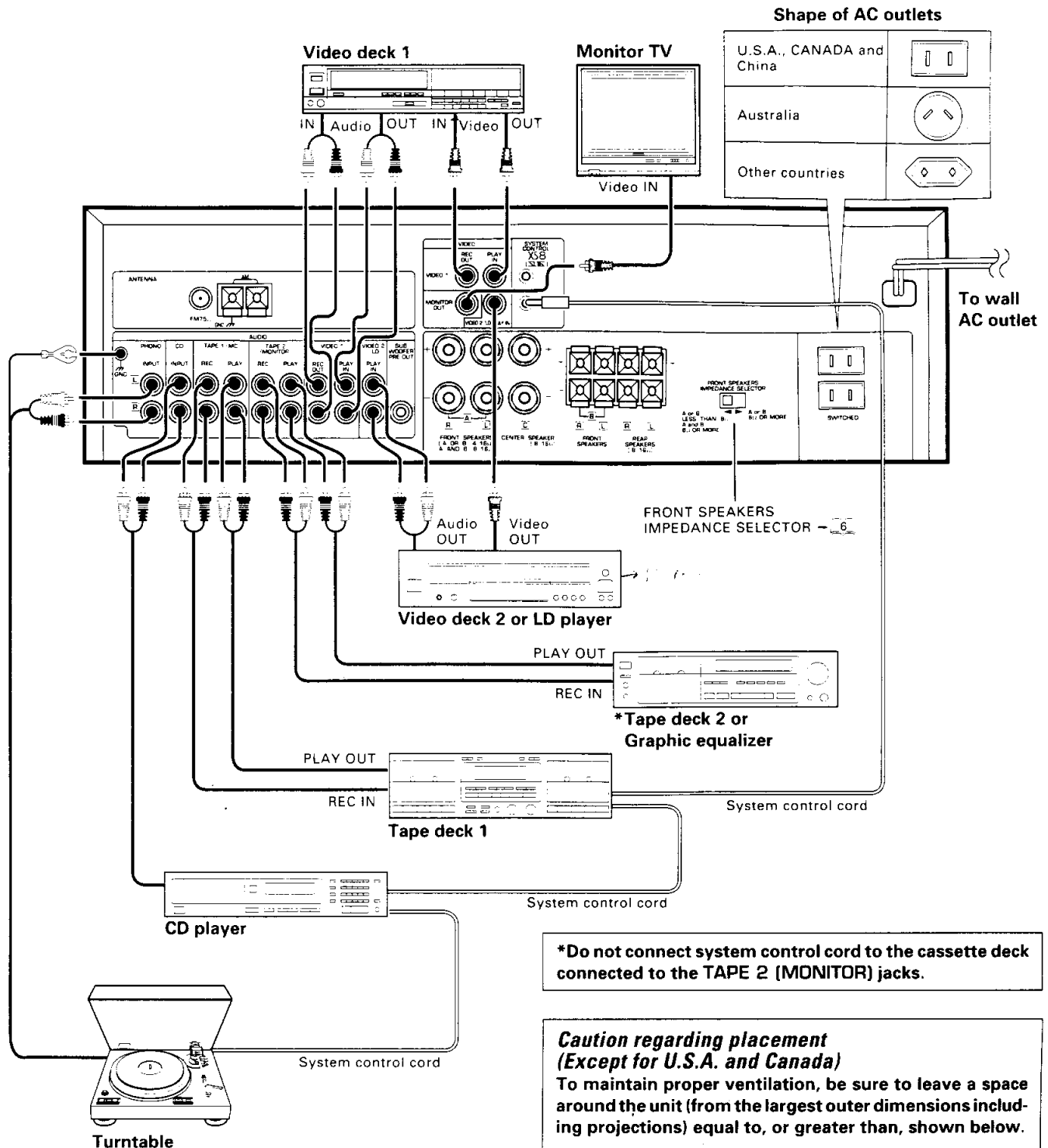

***Do not connect system control cord to the cassette deck connected to the TAPE 2 (MONITOR) jacks.**

Caution regarding placement (Except for U.S.A. and Canada)
To maintain proper ventilation, be sure to leave a space around the unit (from the largest outer dimensions including projections) equal to, or greater than, shown below.

- Left and right panels: 10 cm
- Rear panel: 10 cm
- Top panel: 50 cm

About the system control connections

Connecting system control cords after connecting a KENWOOD audio component system lets you take advantage of convenient system control operations.

There are two KENWOOD system control modes. Make connections according to the groups of terminal symbols shown below.

[XS8] Mode: lets you combine **[XR]**, **[XS]**, and **[XS8]** terminals

[SL16] Mode: for **[SL16]** terminals only

This unit is compatible with both **[XS8]** and **[SL16]** modes. It comes from the factory set to the **[XS8]** mode. To switch to the **[SL16]** mode, follow the instructions in "SWITCHING FROM **[XS8]** TO **[SL16]**" below.

EXAMPLE: **[XS8]** mode connections

The underlined portion represents the setting of the system control mode.

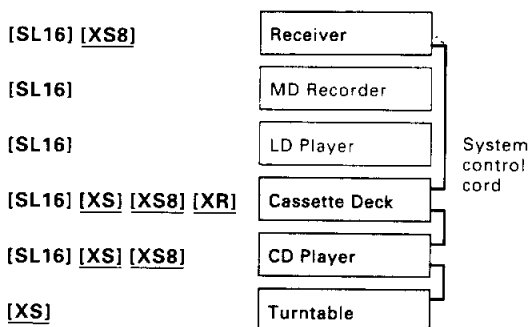

EXAMPLE: **[SL16]** mode connections

The underlined portion represents the setting of the system control mode.

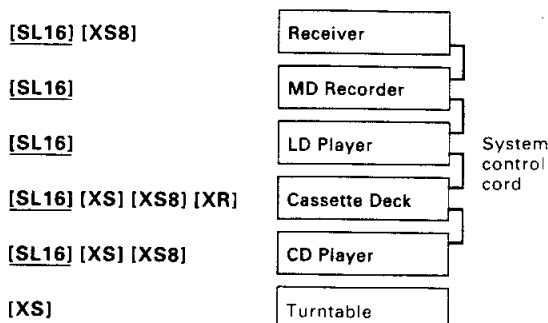

- Some CD players and cassette decks are not compatible with the **[SL16]** system control mode. Be sure to use the **[XS8]** system control mode when making system connections with equipment that is not **[SL16]** compatible.
- Some LD players and MD players are not system control compatible. You cannot make system control connections to this kind of equipment.



1. **[SL16]** equipment cannot be combined with **[XR]**, **[XS]**, and **[XS8]** equipment for system operations. If your equipment consists of this kind of combination, please do not connect any system control cords. Even without system control cords, normal operations can be carried out without affecting performance.
2. Do not connect system control cords to any components other than those specified by KENWOOD. It may cause a malfunction and damage your equipment.
3. Be sure the system control plugs are inserted all the way in to the system control terminals.



ABOUT THE SYSTEM CONTROL OPERATIONS

Remote Control (Except **[SL16]**)

Lets you operate source components with the system remote supplied with this unit.

Automatic Operation (Except **[XR]** equipment)

When you start playback from a source component, the input selector on this unit switches to that component automatically. (Except TAPE 2)

Synchronized Recording (Except **[XR]** equipment)

Lets you synchronize recording with the start of playback when recording from CD, MD, LD, or analog discs.

SWITCHING FROM **[XS8]** TO **[SL16]**

You can easily change the system control mode with the following operation. Do this operation after completing all connections.

Switching to **[SL16]:** Hold down the **AUTO** key and switch the **MAIN POWER** key from **OFF** to **ON**.

Switching back to **[XS8]:** Hold down the **BAND** key and switch the **MAIN POWER** key from **OFF** to **ON**.

- This operation will not affect items stored in the memory.



The system control mode will revert to **[XS8]** if the unit is not turned on for three consecutive days. If you would like to make the unit completely (and permanently) **[SL16]** compatible, please consult your nearest retailer or the Kenwood Marketing Department.



1. Connect all cords firmly. If connections are loose, there could be loss of sound or noise produced.
2. When plugging and unplugging connection cords, be sure to first remove the power cord from the AC outlet. Plugging / unplugging connection cords without removal of the power cord can cause malfunctions or damage to the unit.
3. Do not connect up a power source which is larger than that indicated on the socket at the rear of the unit.
4. If the system control cords or audio cords are not connected properly, the remote control or automatic operation between system components will not work properly.

6 Connection of speakers

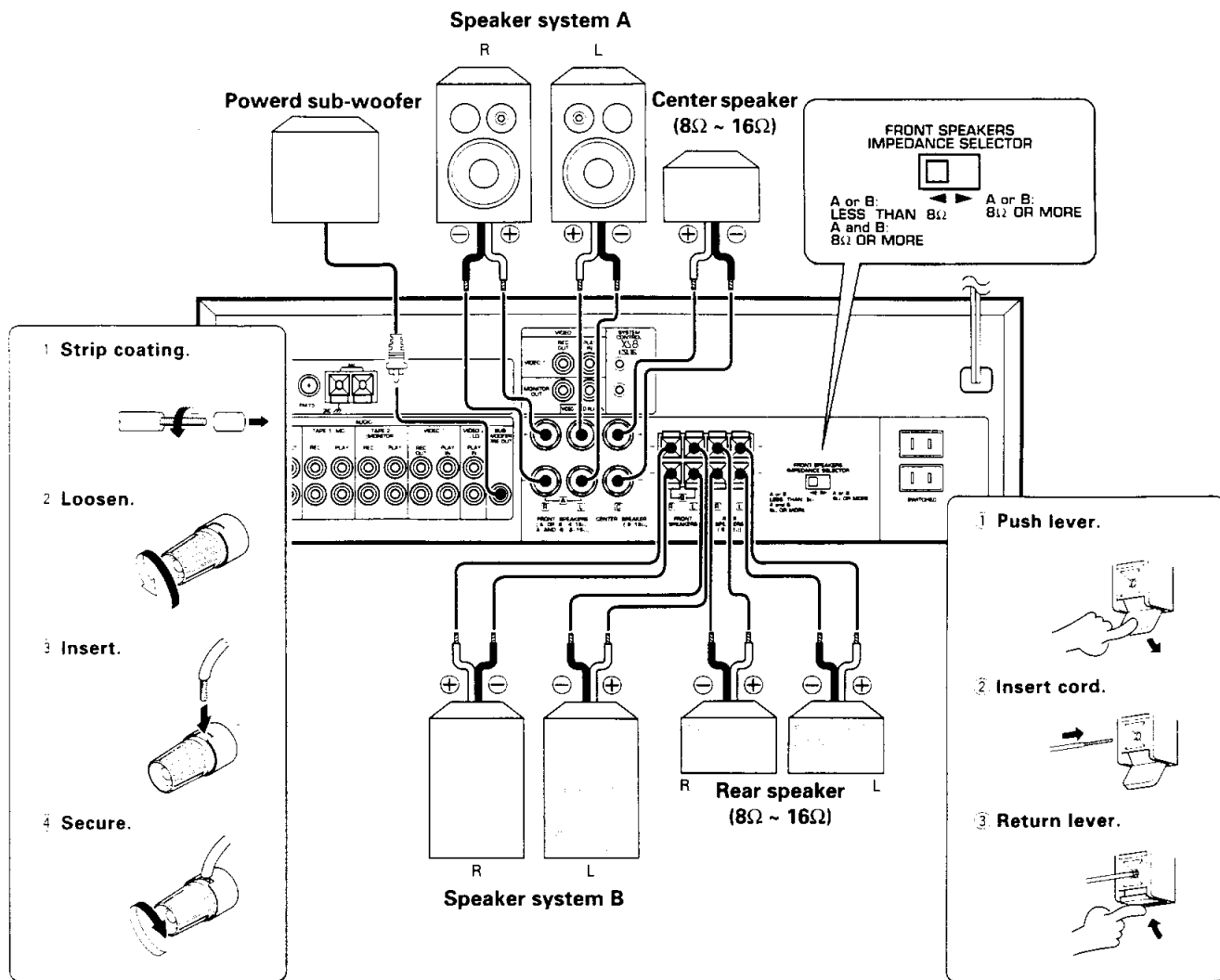

- Never short-circuit the + and - speaker cords.
- If the left and right speakers are connected inversely or if the speaker cords are connected with reversed polarity, the sound becomes unnatural with ambiguous acoustic image positioning. Be sure to connect the speakers and speaker cords correctly.
- Connect a sub woofer if you want to enhance the bass sound.

Setting the speaker IMPEDANCE SELECTOR

CAUTION: TO PREVENT FIRE OR DAMAGE REQUIRING SERVICE, SET THE IMPEDANCE SELECTOR SWITCH AS DESCRIBED BELOW.

When using the speaker A or speaker B separately

Speaker impedance	Selector position
4 Ω, 6 Ω	
8 Ω, 16 Ω	

When using the speaker A and B simultaneously

Speaker impedance	Selector position
8 Ω, 16 Ω	

According to the impedance of the speakers used, set the speaker **IMPEDANCE SELECTOR** on the rear panel as shown in the table.

- When the **IMPEDANCE SELECTOR** switch is set to "**A or B: LESS THAN 8Ω, A and B: 8Ω OR MORE**", it is possible to use the A and B speakers at the same time. Therefore, when using the speakers A and B simultaneously, be sure to set the **IMPEDANCE SELECTOR** switch to the "**A or B: LESS THAN 8Ω, A and B: 8Ω OR MORE**" position.
- During speaker system connection and operation of the speaker **IMPEDANCE SELECTOR**, set the **REMOTE POWER** key to OFF.

Connection of antenna

7

Connection method to each antenna terminal

1 Push lever.

2 Insert cord.

3 Return lever.

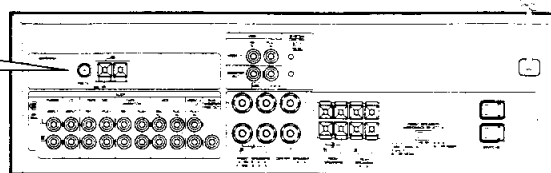
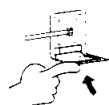
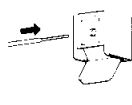
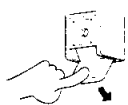

AM loop antenna connection

The supplied antenna is for indoor use. Place it as far as possible from the main system, TV set, speaker cords and power cord, and set it to a direction which provides the best reception.

AM outdoor antenna connection

If the reception is poor when the AM loop antenna is used, distribute a vinyl-coated wire of more than 6 meters outdoors, without disconnecting the loop antenna.

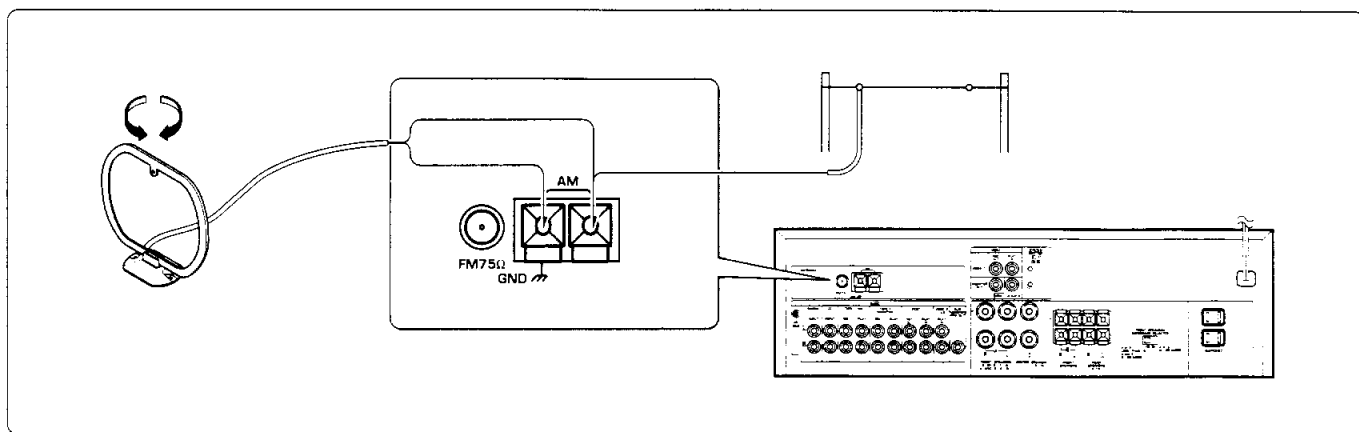

FM indoor antenna connection

The accessory antenna is for temporary indoor use only. For stable signal reception we recommend using an outdoor antenna. Remove the indoor antenna if you connect one outdoors.

FM outdoor antenna connection

Lead the 75 Ω coaxial cable connected to the FM outdoor antenna into the room and connect it to the FM 75 Ω terminal.

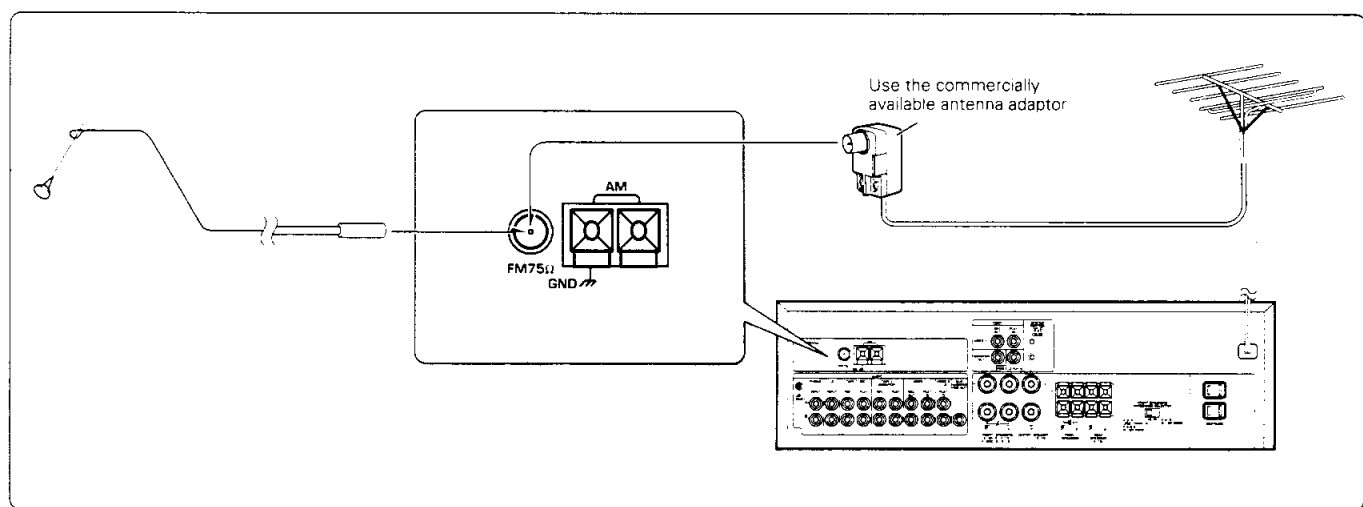

FM DE-EMPHASIS / CHANNEL SPACE switch (Except for U.S.A., Canada and Australia)

The FM DE-EMPHASIS / CHANNEL SPACE switch on the rear panel is set to the correct setting that prevails in the area to which the unit is shipped. However, if the FM DE-EMPHASIS / CHANNEL SPACE setting is not matched to the area where the unit is to be used; for instance, when you moved from area 1 to area 2 or vice versa, desired reception of AM / FM broadcasts is not expected. In this case, change the FM DE-EMPHASIS / CHANNEL SPACE setting in accordance with the area corresponding to the table. The FM DE-EMPHASIS is switched over at the same time.

- When changing the setting of the FM DE-EMPHASIS / CHANNEL SPACE switch, first disconnect the power cord of the amplifier, then reset the channel space switch, connect the power cord again, and turn the power on.

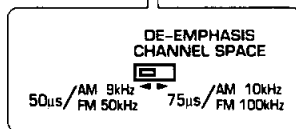
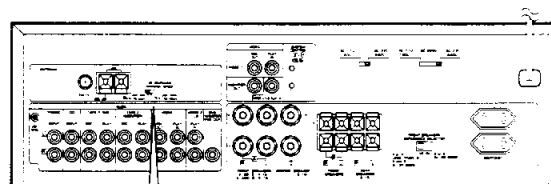

	Area	CHANNEL SPACE freq.	FM DE-EMPHASIS
1	U.S.A., Canada, Hawaii, South American countries	FM: 100kHz AM: 10kHz	75 µs
2	Other countries	FM: 50kHz AM: 9kHz	50 µs

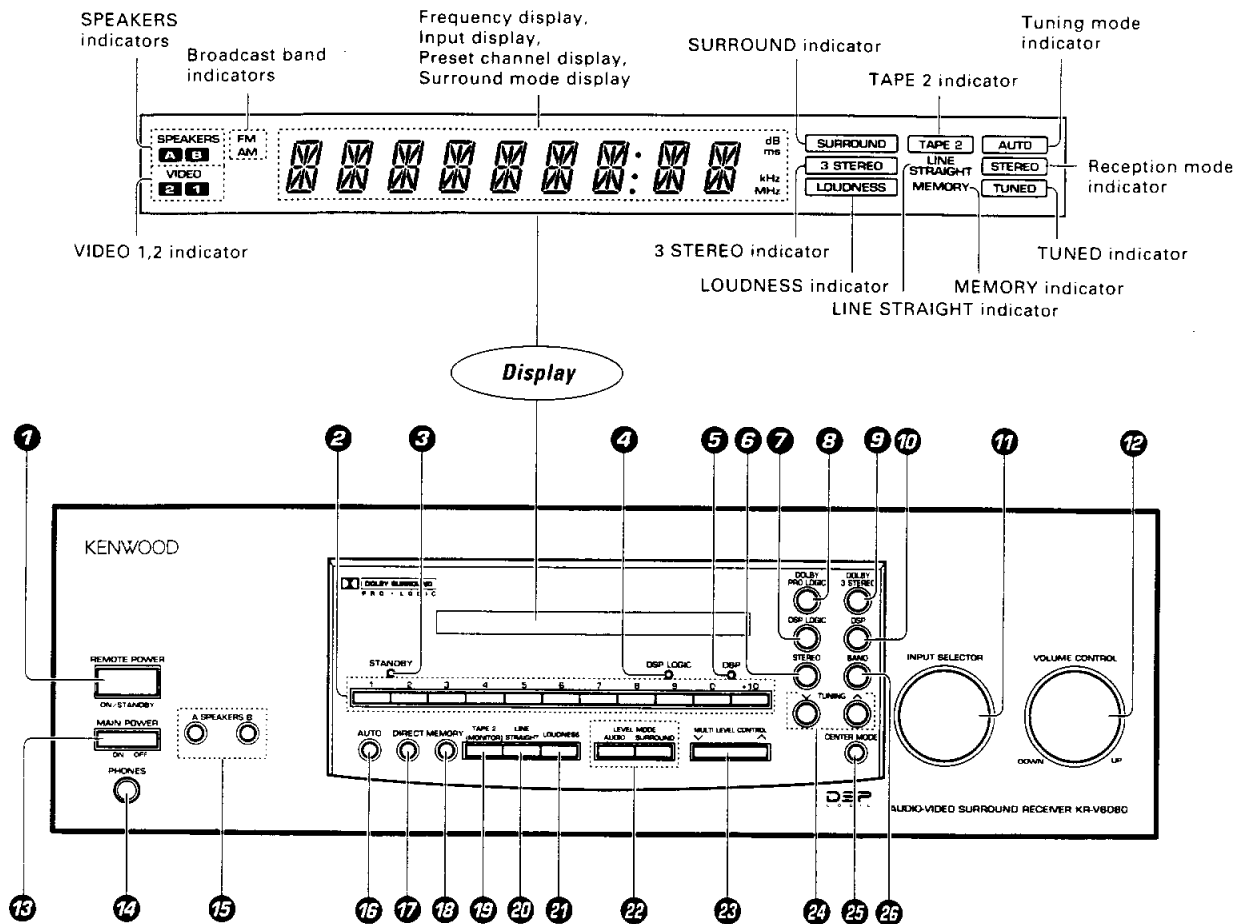

① REMOTE POWER key

Press to switch over the STANDBY/ON modes when the MAIN POWER is ON.

② Numeric keys

③ STANDBY indicator

④ DSP LOGIC indicator

Lights when the DSP LOGIC mode is ON.

⑤ DSP indicator

Lights when the DSP presence mode is ON.

⑥ STEREO key

Press to cancel the surround modes.

⑦ DSP LOGIC key

⑧ DOLBY PRO LOGIC key

⑨ DOLBY 3 STEREO key

⑩ DSP key

⑪ INPUT SELECTOR knob

Turn to select the input sources.

⑫ VOLUME CONTROL knob

⑬ MAIN POWER switch

Press to switch the main power ON/OFF.

⑭ PHONES jack

Used for headphone listening.

⑮ SPEAKERS A/B keys

Press to select the A and/or B speaker systems.

⑯ AUTO key

Press to select the auto tuning mode.

⑰ DIRECT key

Press for direct station tuning based on numerical input.

⑱ MEMORY key

Press to preset a station in the memory.

⑲ TAPE 2(MONITOR) key

Press to monitor the sound being recorded.

⑳ LINE STRAIGHT key

Press to listen to a source with high quality sound.

㉑ LOUDNESS key

Press to enhance low frequencies.

㉒ LEVEL MODE (AUDIO, SURROUND) keys

AUDIO key:

Press when adjusting the tone.

SURROUND key:

Press when adjusting the surround modes.

㉓ MULTI LEVEL CONTROL key

Press to adjust the tone or surround mode setting.

㉔ TUNING keys

Press to tune broadcast stations.

㉕ CENTER MODE key

Press to select the center mode in the DOLBY PRO LOGIC surround mode.

㉖ BAND key

Press to switch the broadcast band.

STANDBY mode of REMOTE POWER key

When the power cord of this system is plugged in to a power outlet and the **MAIN POWER** switch is pressed to ON, the **STANDBY** indicator lights up regardless of the **REMOTE POWER** key setting. This indicates that a small amount of current is being supplied to the unit to back up the memory contents. This mode is referred to as the Standby mode. While the **STANDBY** indicator is lit, the power of the system can also be switched ON/OFF from the remote control unit.

Operation of remote control unit

KR-V8080/KR-V7080 (E/F)

Names of keys and their functions

The remote control unit provided with unit functions in the following two modes so that it can be used to control other KENWOOD system components as well as video components from other manufacturers.

KENWOOD component control mode This mode is used to control the KENWOOD source components including cassette decks and a CD player. (The controlled components must be connected to this unit through system control cords. - 5 -)

Video component control mode This mode allows to control the basic operations of video components from KENWOOD as well as other manufacturers. For details, refer to "Applied functions of the remote control unit". - 29 -
(The set-up codes of these components should be preset to enable their control.)

Some of the keys act in different ways depending on the modes described above. Therefore, be sure to adjust the required mode before pressing these keys.

MACRO key

Press for automatic control of several components (MACRO PLAY).

Controlled component selection keys

Pressing any of these keys initiate the video component control mode. Press one of these keys to select the video component to be remote controlled.

Numeric keys

Used as the numeric keys of the input source component being selected.

Controlled component selection keys

Pressing any of these keys initiate the KENWOOD component control mode. Press one of these keys to select the component to be remote controlled.

ANY keys

Press to adjust the tone or surround mode setting.

LEVEL MODE keys

AUDIO key

Press when adjusting the tone

SURROUND key

Press when adjusting the surround modes.

STEREO key

Press to cancel the surround modes.

SURROUND MODE key

Press to select the surround mode of the receiver unit

Model: RC-R0803 Infrared ray system

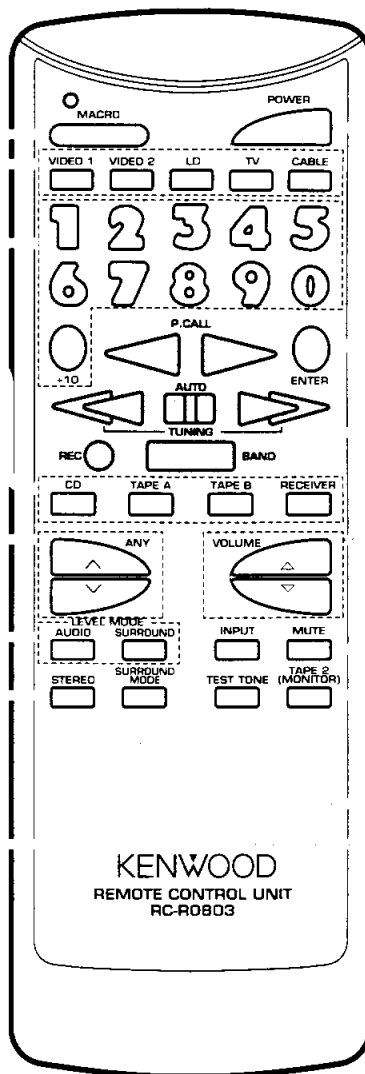

POWER key

Press to switch ON/OFF the power of this unit as well as the KENWOOD components connected to it through system control cords.

ENTER key

Used to preset the set-up codes of video components and in the MACRO PLAY operation.

Refer to the remote control key correspondence table on the next page.

VOLUME keys

Press to adjust the volume.

MUTE key

Press to mute sound temporarily.

TAPE 2(MONITOR) key

Press to monitor the sound being recorded.

TEST TONE key

Press when adjusting the speaker volumes in the surround modes.

INPUT key

Press to select the inputs.

Loading batteries

1 Remove the cover.

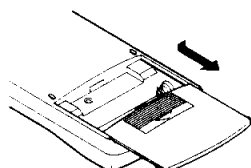

2 Insert batteries.

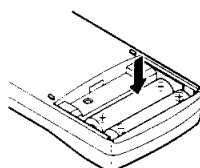

3 Close the cover.

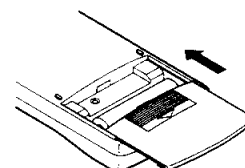









- Insert two AA-size (R6 / SUM-3) batteries as indicated by the polarity marking.

Operation procedure

- 1** Switch ON the power of the main unit.
- 2** Select the component to be remote controlled with one of the controlled component selection keys.
- 3** Refer to the remote control key correspondence table below and press the key for the desired operation.

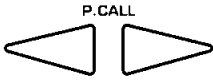
- When two operation keys on the remote control unit are pressed successively, press each key securely reserving an interval of more than 1 second for each press.

Remote control key correspondence table (For KENWOOD component control mode)

Controlled component selection key Operation key	RECEIVER 	CD 	TAPE A 	TAPE B 
 P.CALL	P.CALL keys Recalls preset stations.	▶/ (Play/pause key) (Right key only)	◀, ▶ (Play key)	◀, ▶ (Play key)
 AUTO	AUTO key Press to select the auto tuning mode.	DISC SKIP key Press to select the disc to be played.	 (Pause key)	 (Pause key)
 TUNING	TUNING keys Press to tune broadcast stations.	◀◀, ▶▶ (Skip key)	◀◀, ▶▶ (Fast Forward/Rewind keys)	◀◀, ▶▶ (Fast Forward/Rewind keys)
 REC	—	—	● (Record key)	● (Record key)
 BAND	BAND key Press to switch the broadcast band.	■ (Stop key)	■ (Stop key)	■ (Stop key)

Approximate operating range

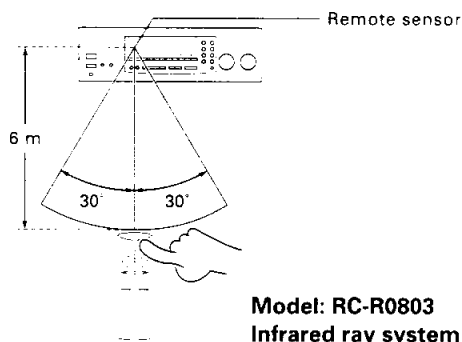

1. The supplied batteries are intended for use in operation checks. Therefore, their lives may be shorter than ordinary batteries.
2. When the remote-controllable distance gets shorter than before, replace both batteries with new ones.
3. Malfunction may occur if direct sunlight or the light of a high-frequency lighting fluorescent lamp enters the remote control light sensor. In such a case, change the system installation position to prevent the malfunction.

Playing music

KR-V8080/KR-V7080 (En)

2

Preparation

- Press the **MAIN POWER** key to ON.

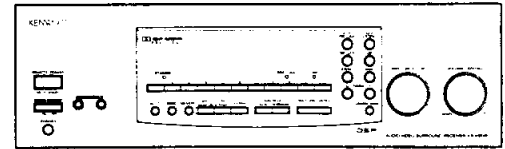
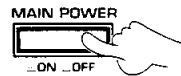

: Keys or controls to be used in this operation

1 Turn the power ON.

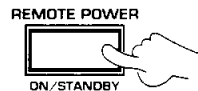
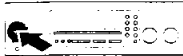

2 Select the **SPEAKERS** key setting.

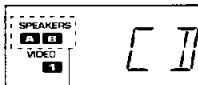
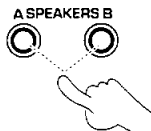

The indicators of the speaker systems to be used should light up.

A, B OFF

Sound is not output from the speakers. Use this setting for listening through headphones, etc.

A ON

Sound is output from the speakers connected to the SPEAKERS A terminals on the rear panel.

B ON

Sound is output from the speakers connected to the SPEAKERS B terminals on the rear panel.

A, B ON

Sound is output from the speakers connected to the SPEAKERS A and B terminals on the rear panel.

- When a surround mode is activated while both SPEAKERS A and B are ON, the SPEAKERS B system is automatically switched off. If the **SPEAKERS B** key is pressed at this time, the SPEAKERS B system is switched ON and the SPEAKERS A system is switched OFF automatically.
- Output to the sub woofer is not turned off even if you turn off both SPEAKER A and B.

3 Select the **input source**.

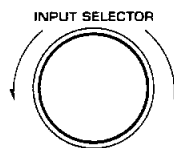
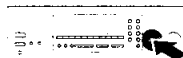

The input sources are switched in the following order:

- 1 **TUNER** (frequency display)
- 2 **PHONO**
- 3 **CD**
- 4 **VIDEO2 (LD)***
- 5 **VIDEO1**
- 6 **TAPE1 (MD)***

The selected source is displayed.

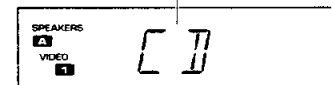

4 Play the selected source.

5 Adjust the volume.

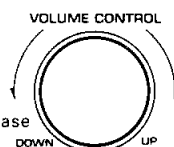
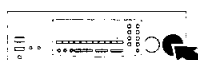

To decrease volume DOWN To increase volume UP

Volume level is displayed.

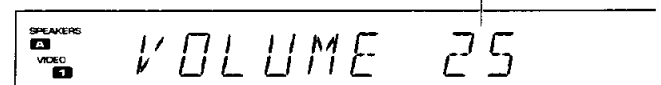

- The sound of input source cannot be listened to while **TAPE 2(MONITOR)** is ON.

Sound adjustment functions



When adjusting the tone or balance using the remote control unit, first press the **RECEIVER** key of the remote control unit before adjusting.

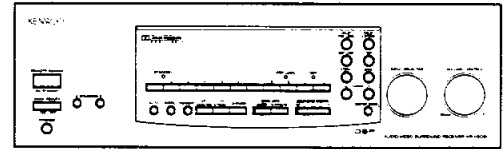
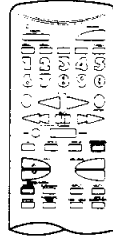

: Keys or controls to be used in this operation

Adjusting the tone

- 1 Select the tone mode to be adjusted. (BASS, TREBLE, SUBWOOFER)

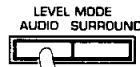

- 2 Adjust the tone.

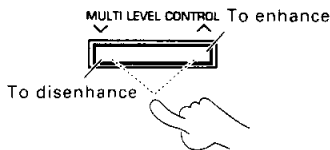
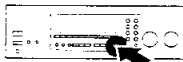

Each press of the key switches the mode as follows:

- 1 **L --- R (BALANCE)**: The mode for adjusting the volume balance between the left and right.
- 2 **BASS (BASS)**: The mode for adjusting the low frequencies.
- 3 **TREBLE (TREBLE)**: The mode for adjusting the high frequencies.
- 4 **SUB-WF (SUBWOOFER)**: The mode for adjusting the very low frequencies.

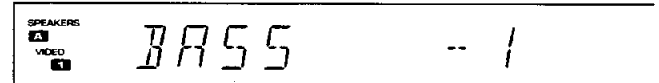

Display when "BASS" is selected.

The displayed value changes.

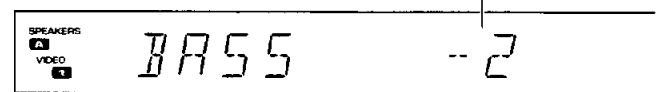

Adjusting the left/right sound balance

- 1 Select "BALANCE".

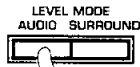
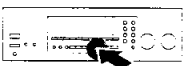

- 2 Adjust the balance.

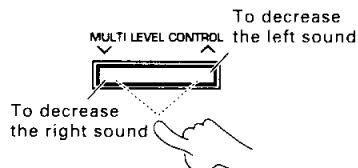

Each press of the key switches the mode as follows:

- 1 **L --- R (BALANCE)**: The mode for adjusting the volume balance between the left and right.
- 2 **BASS (BASS)**: The mode for adjusting the low frequencies.
- 3 **TREBLE (TREBLE)**: The mode for adjusting the high frequencies.
- 4 **SUB-WF (SUBWOOFER)**: The mode for adjusting the very low frequencies.

Indicates the center.

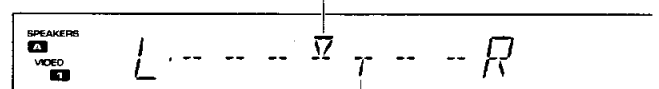

Indicates the balance setting.

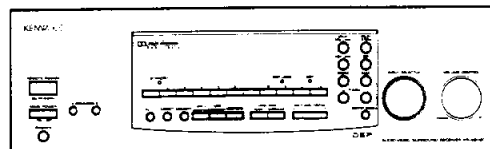
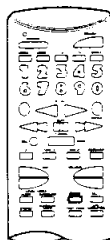

: Keys or controls to be used in this operation

Playback with Line Straight

This feature allows you to enjoy music sources such as CD with an even higher sound quality.

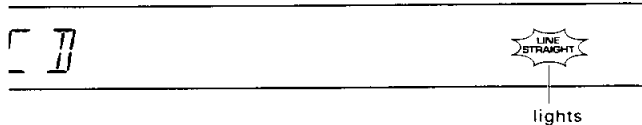
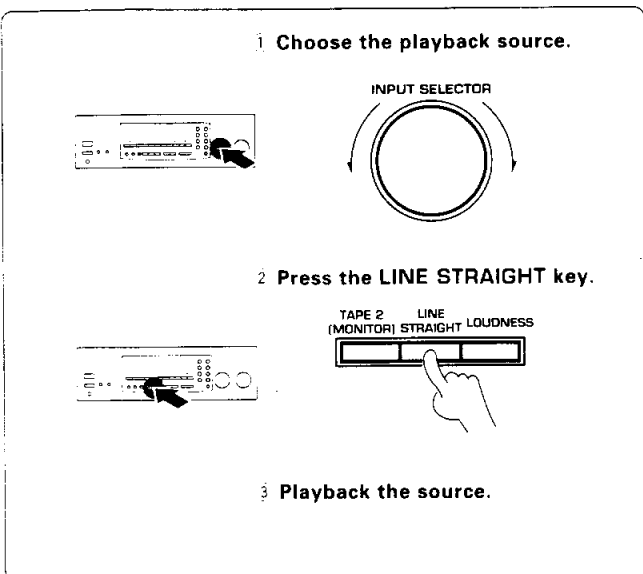

- During LINE STRAIGHT play, the tone control such as BASS and TREBLE adjustments is defeated.
- Pressing keys related to surround sound will cancel line straight playback.

To cancel

Press the LINE STRAIGHT key again.

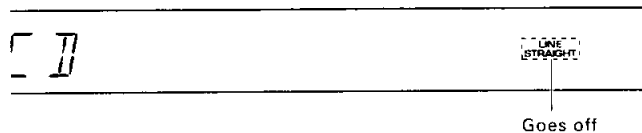

Compensating for low frequencies (LOUDNESS)

The LOUDNESS function is used to compensate for the low frequencies which are less audible during low-volume listening.

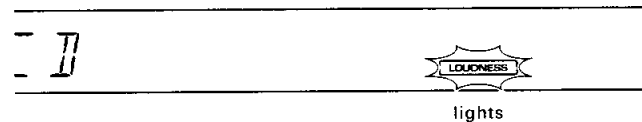
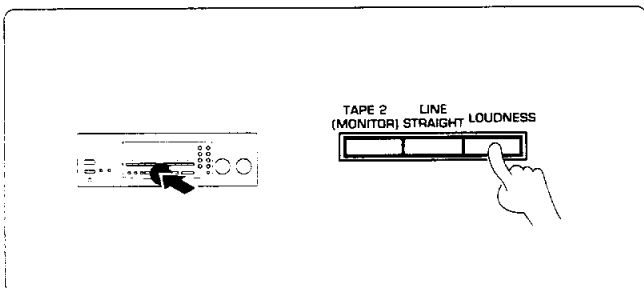

To cancel

Press the LOUDNESS key again.



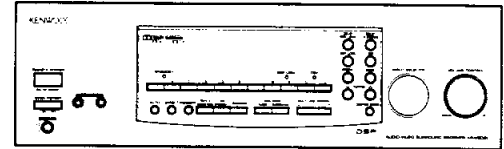
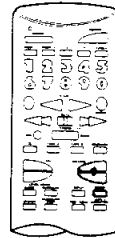

: Keys or controls to be used in this operation

To listen through headphones

- 1 **Set both of the SPEAKERS keys to OFF.**
- 2 **Plug headphones.**
- 3 **Adjust the volume.**

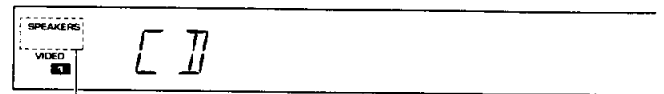

Make sure the light is out.

- Output to the sub woofer is not turned off even if you turn off both SPEAKERS A and B.

To mute sound temporarily

Remote control unit only

MUTE

Press again to return to the original volume.

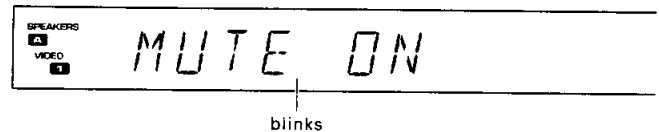

To cancel
 Press the MUTE key again.

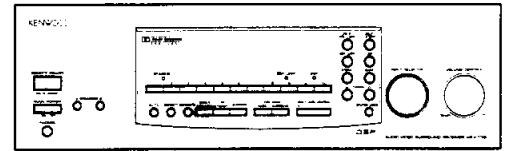
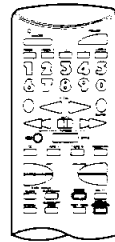

○ : Keys or controls to be used in this operation

To record a music source

- 1 Select the source to be recorded.

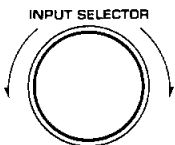

INPUT SELECTOR

Select an input source other than TAPE 1.

- 2 Put the cassette deck in record-pause mode.
- 3 Play the source and start recording.

The input sources are switched in the following order:

- 1 TUNER (frequency display)
- 2 PHONO
- 3 CD
- 4 VIDEO2 (LB)
- 5 VIDEO1
- 6 TAPE1 (MB)

Copying tape (Tape dubbing TAPE 2 → TAPE 1)

- 1 Press the TAPE 2(MONITOR) key.



TAPE 2 (MONITOR) LINE STRAIGHT LOUDNESS

- 2 Select a source other than TAPE 1.

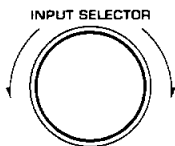

INPUT SELECTOR

- 3 Play cassette deck 2 and start recording on cassette deck 1.

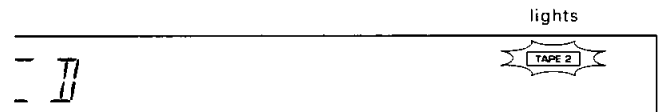

- For copying a tape using a double cassette deck, read the instruction manual of the double cassette deck.

Copying tape (Tape dubbing TAPE 1 → TAPE 2)

- 1 Select TAPE 1 with the INPUT SELECTOR control of the main unit.
- 2 Play the cassette deck connected to the TAPE 1 jacks and start recording of the cassette deck connected to the TAPE 2 jacks.

Regarding TAPE 2 (MONITOR)

A cassette deck or graphic equalizer can be connected to this unit's **TAPE 2 (MONITOR)** terminals. If you connect a graphic equalizer, turn the **TAPE 2 (MONITOR)** key ON. If you connect a 3-head cassette deck, you can monitor the source sound, or the sound being recorded, while recording. Pressing the **TAPE 2 (MONITOR)** key lets you compare the recorded sound and the source sound. Refer to the operating manual for the component you connected for further details.

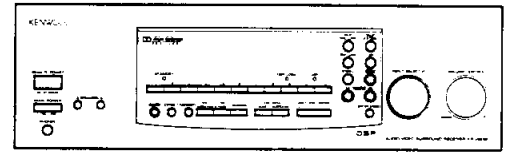
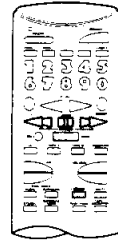

: Keys or controls to be used in this operation

Receiving broadcast stations

1 Select the TUNER input.

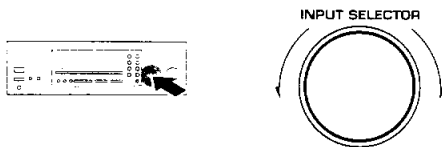

The input sources are switched in the following order:

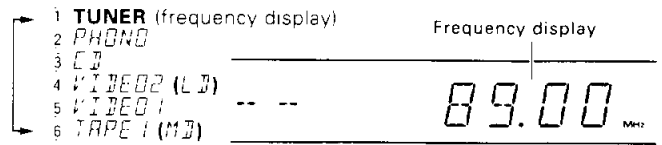

- The last frequency tuned before is displayed.

2 Select the broadcast band.

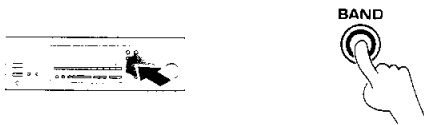

Each press switches the band as follows:

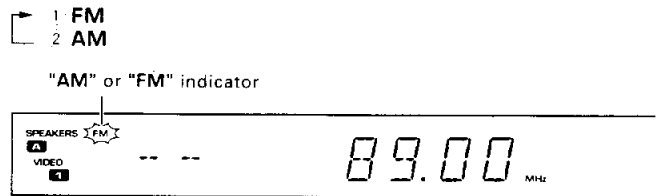

Each press switches the tuning method as follows:

3 Select the tuning method.

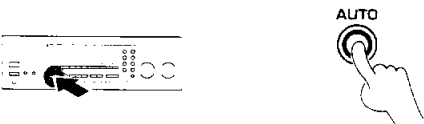

- 1 **AUTO** lit (auto tuning)
- 2 **AUTO** not lit (manual tuning)

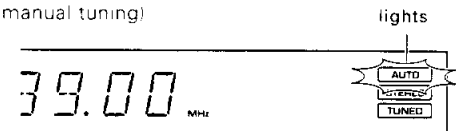

- Usually, set the switch to **AUTO** (auto tuning).

Select manual tuning when noise interferes due to weak radio wave. (The stereo broadcasting is received in monaural during manual tuning.)

4 Select a station.

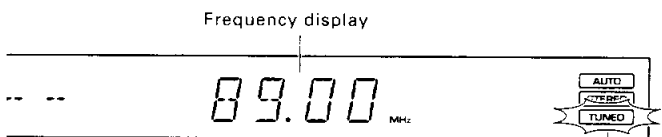
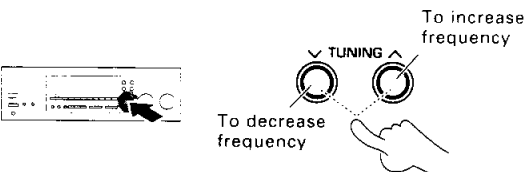

"TUNED" lights up when a station is tuned.

Auto tuning: The next station found is tuned automatically.
Manual tuning: Press repeatedly or hold until a station is tuned.

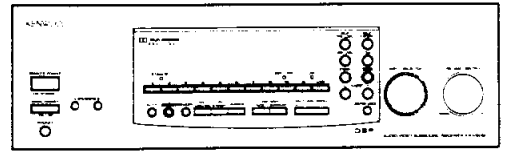
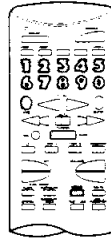

: Keys or controls to be used in this operation

Receiving radio stations by specifying its frequency

1 Select the TUNER input.

2 Select the broadcast band.

3 Specify the frequency.

1 Press the DIRECT key.

2 Enter the frequency of the desired station.

The input sources are switched in the following order:

- 1 TUNER (frequency display)
- 2 PHONO
- 3 CD
- 4 VIDEO2 (LB)
- 5 VIDEO1
- 6 TAPE1 (MD)

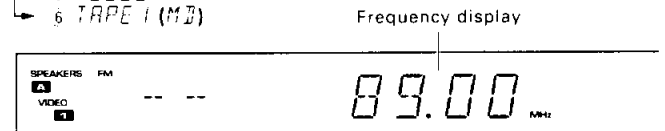

Each press switches the band as follows:

- 1 FM
- 2 AM

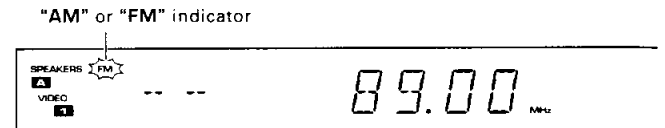

Press the numeric keys according to the frequency to be tuned as shown below

*AM10kHz/FM100kHz territories (U.S.A., Canada, etc.)

AM 810 kHz	[8] [1]	(10 kHz space)
AM 1260 kHz	[1] [2] [6]	(10 kHz space)
FM 90 MHz	[9] [0] [0]	(100 kHz space)
FM 102.5 MHz	[1] [0] [2] [5]	(100 kHz space)

*AM9kHz/FM50kHz territories (other countries)

AM 810 kHz	[8] [1] [0]	(9 kHz space)
AM 1260 kHz	[1] [2] [6] [0]	(9 kHz space)
FM 90 MHz	[9] [0] [0] [0]	(50 kHz space)
FM 102.5 MHz	[1] [0] [2] [5] [0]	(50 kHz space)

*FM DE-EMPHASIS/CHANNEL SPACE switch

"TUNED" lights up when a station is tuned.

• If you make a mistake, the frequency display blinks for a few seconds. In this case, repeat step 3 from the beginning.

Preparation

- Tune the station to be stored in memory. - 17
- Press the **RECEIVER** key of the remote control unit to initiate the receiver control mode.

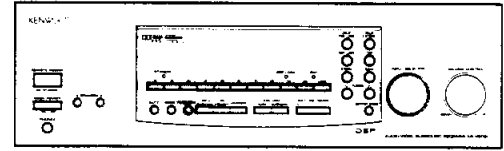
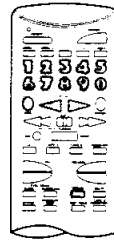

: Keys or controls to be used in this operation

Storing radio stations in memory (Station preset)

1 Press the **MEMORY** key during receiving a station.



MEMORY



Proceed to step 2 within 5 sec.

(If more than 5 sec. have elapsed, press the **MEMORY** key again.)

2 Select one of the preset numbers from 1 to 40.

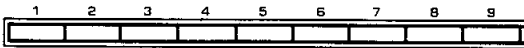

Lights up (for 5 sec.)

Press the numeric keys in the following order.

To store in "15" ... **+10**, **5**

To store in "20" ... **+10**, **+10**, **0**

- Repeat steps 1 and 2 for each of the stations to be stored in memory.
- If a station is stored in a preset number which has already stored a station memory under it, the previous memory is replaced by the new memory content.

Receiving a preset station

1 Select the **TUNER** input with the **INPUT SELECTOR**.



INPUT SELECTOR



2 Press the preset number of the desired station.

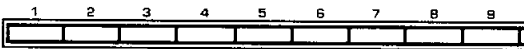

Press the numeric keys in the following order.

To recall "15" ... **+10**, **5**

To recall "20" ... **+10**, **+10**, **0**

- If you make a mistake in entering the figure of 10, press the **+10** key repeatedly until the original display is shown, then enter the correct number.

Preset number stored in memory

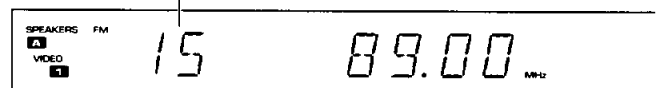

Receiving all preset stations in order



The preset number increases.

P.CALL

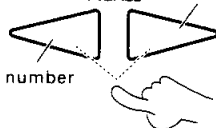

The preset number decreases.

- Every time the key is pressed, the next station in the order of the preset number is received.

When you press **>** key, ... 1 → 2 → 3 38 → 39 → 40

When you press **<** key, ... 1 ← 2 ← 3 38 ← 39 ← 40

If the key is held pressed Preset stations will be received successively for about half a second each.

Operation of video components

KR-V8080/KR-V7080 (En)

For the connections and operations, also read carefully the instruction manuals of the video components.

20

4

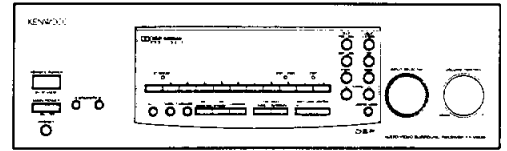
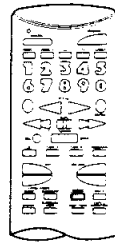

: Keys or controls to be used in this operation

Playback of videotape

1 Turn the power of the monitor TV ON.

2 Select the VIDEO 1 input.



3 Play the video deck.

The input sources are switched in the following order:

- 1 TUNER (frequency display)
- 2 PHONO
- 3 CD
- 4 VIDEO2 (LD)
- 5 VIDEO1
- 6 TAPE1 (MD)

"VIDEO 1" should be displayed.

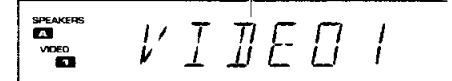

- Select the input to which a video deck is connected.

Recording of video source

1 Connect the video source component to be played.

2 Select the VIDEO 2 input.



3 Play the source component.

4 Start recording on the recording video deck.

- Connect the component to be played to the VIDEO 2 jacks.
- The connectable components include a video deck (playback only), video camera (playback only), LD player or DBS tuner.

The input sources are switched in the following order:

- 1 TUNER (frequency display)
- 2 PHONO
- 3 CD
- 4 VIDEO2 (LD)
- 5 VIDEO1
- 6 TAPE1 (MD)

"VIDEO 2" should be displayed.

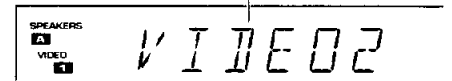

- Start recording with the video deck which is connected to the VIDEO 1 jacks.

Presence play

KR-V8080/KR-V7080 [En]

The surround modes allow you to enjoy the feeling of presence in music. Select the mode according to the source or components played. For the connections of the rear and/or center speakers, refer to "Connection of speakers".

- 6 -

21

DOLBY PRO LOGIC surround mode

Video and LD software programs carrying the  mark contain recording of the same Dolby Surround data as those used in movie theaters.

The DOLBY PRO LOGIC surround mode uses the Dolby Surround data and brings into home a similar sound field with full of presence to movie theatres. To use this mode, connect the rear (and center) speakers.

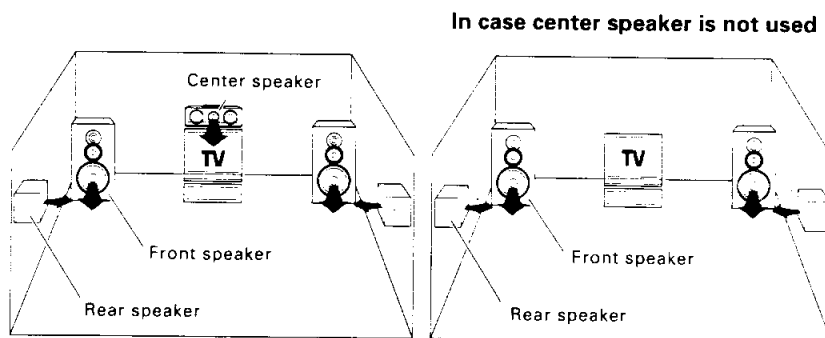

DOLBY 3 STEREO mode

If the left and right speakers are installed apart from each other, the center acoustic image (words, etc.) may vary depending on the listener's position. The DOLBY 3 STEREO mode provides an improved positioning of the center acoustic image regardless of the listening position. To use this mode, connect the center speaker.

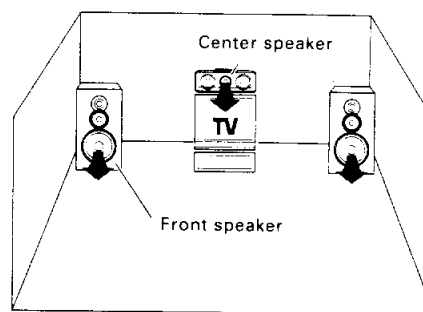

DSP LOGIC mode

DSP LOGIC lets you enjoy the atmosphere of a movie theater in your listening room. By adding the reverberation aspects of a movie theater to the sound from the original music source, you can enjoy the soundscape of either a LARGE or SMALL movie theater. Be sure to connect rear and center speakers when using this mode.

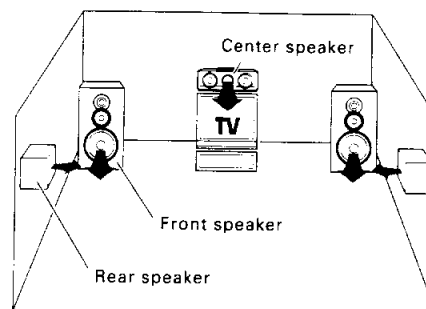

DSP presence mode

This mode provides a live atmosphere to music sources. By adding the reverberation component of one of the three sound fields of this mode, it allows to enjoy three kinds of sound fields (ARENA, JAZZ CLUB, STADIUM) with full of feeling of presence. The sound field can be selected according your liking.

To use this mode, connect the rear speakers.

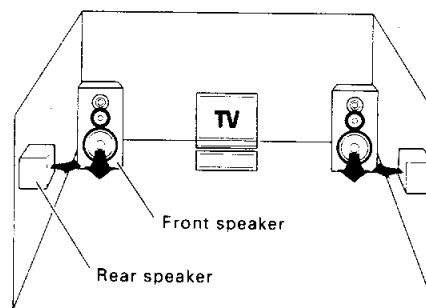

What is DSP?



The DSP stands for Digital Signal Processor. In the DSP presence and DSP LOGIC modes, the reverberation components (elements of sound echoed in various spaces) which determine the feeling of presence are created by digital processing by the DSP without spoiling the sound quality of the original music source.

To improve the feeling of presence in the surround modes, various parameters of each surround mode can be set up according to the speaker system used as well as to the environmental of the listening room. The following procedure let you set the parameters of the surround mode (DOLBY PRO LOGIC, DOLBY 3 STEREO, DSP LOGIC, DSP presence). Once the settings have been done, it is held in memory so re-adjustment is not necessary even after the mode has been changed to other modes (except for the delay time setting).

Recommended speaker installation



It is recommended that the rear speakers are installed straight to the left and right of the listening position or slightly behind, at a height of about 1 meter higher than the listener's ears. Each rear speaker should be installed so that the longer sides are horizontal.

Adjustments for surround play

1 Select the DOLBY PRO LOGIC surround mode.

2 Select the CENTER MODE.

3 Adjust the delay time.

- Calculate the suitable delay time for your listening room.
- Press the RECEIVER key. (Remote control only)
- Select "DELAY".
- Adjust.

How to calculate the proper delay time

Assuming that the distance from the front speaker is A meters and the distance from the rear speakers is B meters

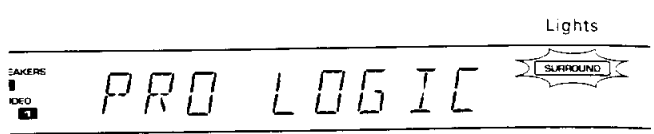

Each press of the **CENTER MODE** key switches the center modes as follows:

- 1 **NORMAL (NORMAL)** : If you use a center speaker.
- 2 **PHANTOM (PHANTOM)** : When the center speaker is not used.

Each press of the key switches the mode as follows:

- 1 **DELAY (DELAY)**
- 2 **CENTER (CENTER)** (Displayed only when "NORMAL" is selected in step 2)
- 3 **REAR (REAR)**

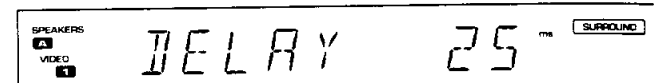

- The delay time can be adjusted in the range from 15 ms to 30 ms, in 5 ms steps.
- This adjustment is also possible with the **MULTI LEVEL CONTROL** key of the main unit.

For the delay time setting of the DSP LOGIC and DSP presence modes, refer to -25-

1 **Use the delay time calculation chart on the right.**
Example: When A = 3 m, B = 3 m, the delay time is 20 ms.

2 **Use the following formula for calculation.**
Delay time = 20 + 3 x (A - B) (Unit: ms)

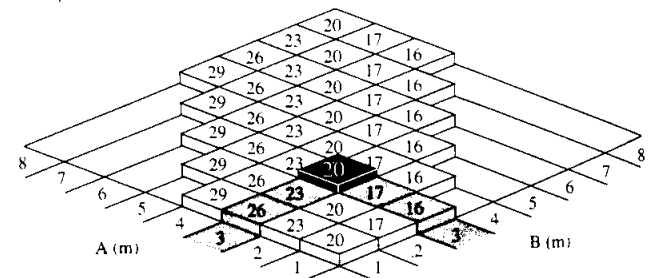

What is delay time?



The sound entering the ears include the direct sound coming from the sound source and the indirect sounds reflected from the walls, floor, ceiling, etc. The indirect sounds are delayed because they travel longer distance required for reflection before they reach the ears. The delay time is the difference in time between the direct sound and indirect sounds.

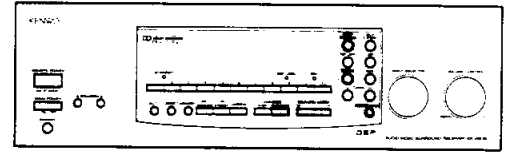
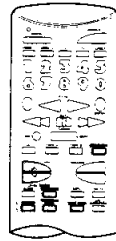

: Keys or controls to be used in this operation

4 Adjust the volume balance.



1 Press the RECEIVER key.
(Remote control only)



2 Generate the test tone.



3 With reference to the front speaker (left, right) volumes, adjust all other speakers to an identical volume level.

(1) While the test tone is output from the desired speaker.

(2) Adjust.

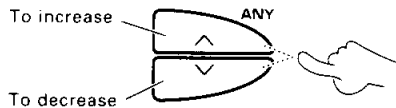

4 Stop the test tone.



• The buzzing test tone moves once every 1.5 seconds.

- TEST L (Front speaker, Left channel)
- TEST E (Center speaker)
(Displayed only when "NORMAL" is selected in step 2)
- TEST R (Front speaker, Right channel)
- TEST S (Rear speaker)

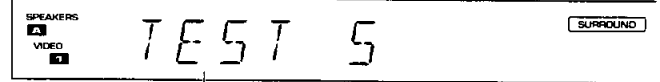

Display when the test tone is output from rear speakers

- Be sure to adjust from your listening position.
- The volume is adjusted in 1dB steps each time you press the ANY (MULTI LEVEL CONTROL) keys.
- The volume levels can be adjusted in the range from -10 dB to +10 dB.
- The ANY keys cannot vary the front speaker (Left, Right) volumes.

To cancel the SURROUND play



Remote control unit



Main unit

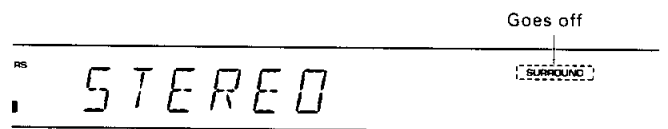

Goes off

When playing videotape (or LD) software carrying the  mark, a sound field with enhanced surround effects can be enjoyed by using the DOLBY PRO LOGIC or DOLBY 3 STEREO mode. Other surround modes can also be used effectively with any kind of source. Be sure to complete "Adjustments for surround play" prior to starting playback in one of these surround modes. - 22

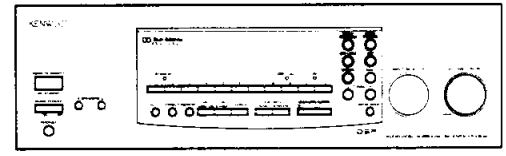
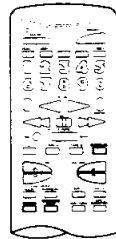



: Keys or controls to be used in this operation



Surround play

1 Select one of the surround modes.

- 1 Press the RECEIVER key. (Remote control only)

- 2 Select the desired surround mode.

- 3 Select the desired sound field. (This step is required only when "DSP LOGIC" or "DSP" is selected in 2. above.)

2 Play a video software program.

3 Adjust the volume.

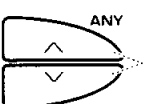
To cancel the SURROUND play

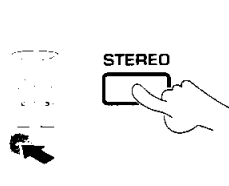

Remote control unit

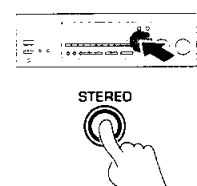

Main unit

Each press of the key switches the modes as follows:

- 1 PRO LOGIC (DOLBY PRO LOGIC)
- 2 3 STEREO (DOLBY 3 STEREO)
- 3 DSP LOGIC (DSP LOGIC)
- 4 DSP (DSP presence)

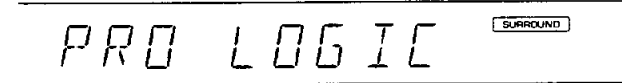

Example when DOLBY PRO LOGIC is selected

For DSP LOGIC mode

- 1 LARGE (LARGE)
Reproduces the presence of a large movie theater.
- 2 SMALL (SMALL)
Reproduces the presence of a relatively small movie theater.

For DSP mode

- 1 ARENA (ARENA)
Reproduces the feeling of sitting in the front row of an arena concert.
- 2 JAZZ CLUB (JAZZ CLUB)
Reproduces crisp cymbal crashes like at a jazz club.
- 3 STADIUM (STADIUM)
Reproduces a feeling of release associated with the near absence of reverberation reflected from the ceiling.

• To change the sound field, repeat step 1 from the beginning.

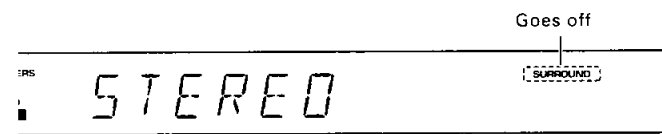

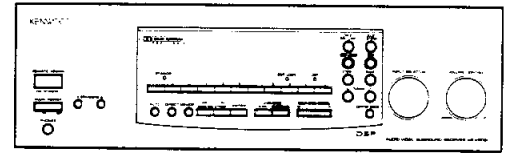
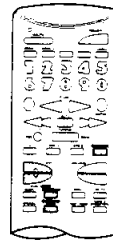

: Keys or controls to be used in this operation

Adjusting the surround effects (DSP LOGIC and DSP presence modes only)

Adjust the delay time.



1 Press the RECEIVER key.
(Remote control only)



2 Select "DSP LOGIC" or "DSP".



3 Select "DELAY".

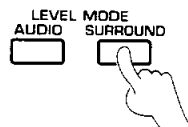

4 Adjust.
(How to calculate the proper delay time → 22.)

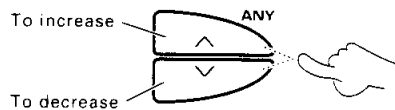

Each press of the key switches the modes as follows:

- 1 PRO LOGIC (DOLBY PRO LOGIC)
- 2 3 STEREO (DOLBY 3 STEREO)
- 3 DSP LOGIC (DSP LOGIC)
- 4 DSP (DSP presence)

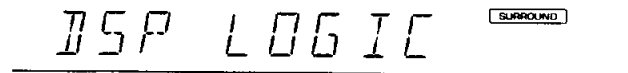

Display when DSP LOGIC mode is selected

Each press of the key switches the mode as follows:

- 1 DELAY (DELAY)
- 2 CENTER (CENTER) (DSP LOGIC only)
- 3 REAR (REAR)

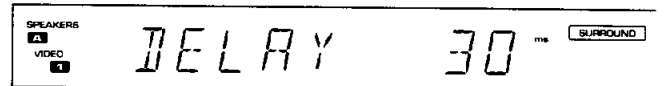

- The delay time can be adjusted in steps to 15, 20, 25, 30, 40 or 50 ms.

Applied functions of the remote control unit

KR-V8080/KR-V7080 (En)

26

The remote control unit provided with this unit is capable of remote controlling the video components (VCR, LD player, monitor TV, etc.) from other manufacturers than KENWOOD as well as KENWOOD components. To make this possible, just preset the set-up code of your video components in the remote control unit.



The set-up codes are designed to be compatible with several models, but there may be some incompatible models. (With some models, only some of the functions can be operated.)

How to preset the set-up codes

1 Find the set-up code of the component to be registered.

Refer to the set-up code list on page 30 and after to find the set-up code of the component to be registered. - 30

Example: To register a VCR made by KENWOOD, 053, 056, 061 or 082

2 Select the component to be registered.

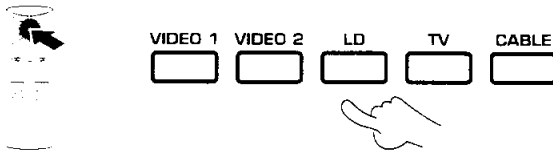

Go to step 3 within 5 sec.

3 Press the ENTER key.



Go to step 4 within 5 sec.

4 Enter the set-up code.

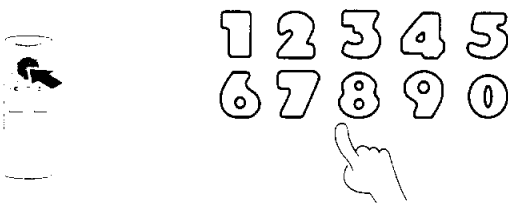

Enter with numeric keys.

Example: [0], [5], [3]

- If you made a mistake entering the set-up code, restart from step 2.



Go to step 5 within 5 sec.

5 Press the ENTER key.



When preset operation has been successful

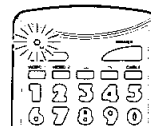

The red indicator blinks twice.

When preset operation has been unsuccessful

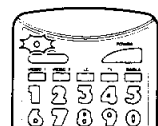

The red indicator lights for a few second and the preset mode is canceled. In this case, restart the procedure from the beginning.

Remote controlling the video components

After having press the set-up codes of your video components, try controlling them from the remote control unit.

- 1** Select the component to be remote controlled with one of the controlled component selection keys.
- 2** Point to the preset component and press the POWER key.
- 3** Refer to the remote control key correspondence table below and press the key for the desired operation.



If the power of the desired component cannot be switched ON, there is a possibility that the optimum set-up code for the component has not been preset. Try pre-setting another set-up code of the same manufacturer.

To turn the power OFF

- 1 Select the source component to be switched OFF.

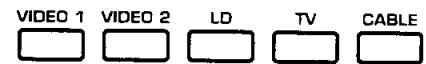

- 2 Press the POWER key.

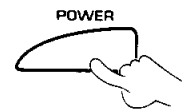

Remote control key correspondence table (For video component control mode)

Controlled component selection key	VIDEO 1 	VIDEO 2 	LD 	TV 	CABLE
POWER 	VCR 1 POWER key	VCR 2 POWER key	LD player POWER key	TV POWER key	CATV POWER key
P.CALL 	(Play key) (Right key only)	(Play key) (Right key only)	(Play key) (Right key only)	TV volume control key	TV volume control key
AUTO 	II (Pause key)	II (Pause key)	II (Pause key)	_____	_____
TUNING 	◀▶, ▶▶ (Fast Forward/ Rewind keys)	◀▶, ▶▶ (Fast Forward/ Rewind keys)	◀▶, ▶▶ (Fast Forward/ Rewind keys)	_____	_____
REC 	● (Record key)	● (Record key)	Open/close key	_____	_____
BAND 	■ (Stop key)	■ (Stop key)	■ (Stop key)	TV muting	TV muting
ANY 	Channel keys	Channel keys	Search keys	Channel keys	Channel keys
LEVEL MODE AUDIO SURROUND (AUDIO key only)	VCR/TV switch key	VCR/TV switch key	_____	VCR/TV switch key	VCR/TV switch key

Automatic operation of several components (MACRO PLAY)

KR-V8080/KR-V7080 (En)

Complicated preparations of the video components including the monitor TV (switching power ON, selecting the channel, etc.) are required before starting visual entertainment. The convenient MACRO PLAY function is capable of storing the preparatory operation steps of these components in the remote control unit, so that simply pressing the MACRO button allows to prepare the video components making them ready for instant enjoyment. (To allow presetting the operation steps of video components, the set-up codes of the components should be preset beforehand. - 26 -)

Preparation for MACRO PLAY

1 Initiate the MACRO setting mode.

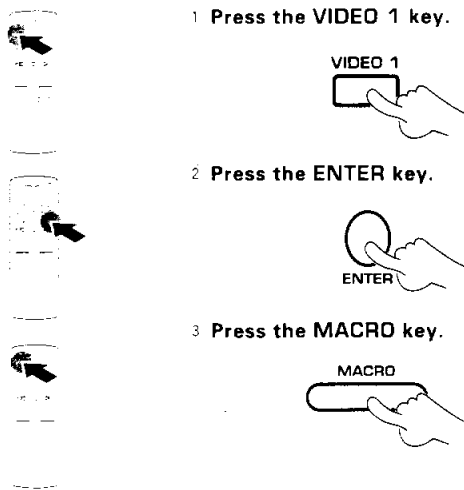

Go to step 2 within 5 sec.

2 Press the keys to be operated in order.

This step sets the preparatory operations for making video components ready. In the following example, the preparations for switching ON the TV and VCR are described.

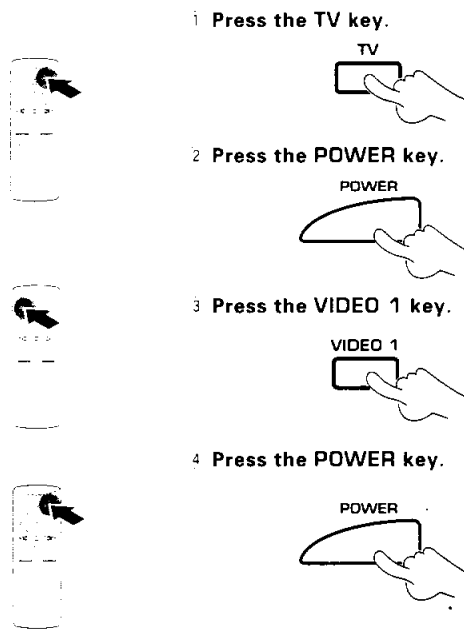

- Up to a total of 13 key operations can be preset. With the example on the left:

1 TV key	1 operation
2 POWER key	1 operation
3 VIDEO 1 key	1 operation
4 POWER key	1 operation
<hr/>	
TOTAL	4 operations.



Press each key within 5 sec. after the previous key.

- The method of selecting a channel of the monitor TV, etc., is variable depending on the type of TV. Check your TV and try with it.

- Pressing the remote's **P.CALL** key (right key only) after step 4, completes the setup preparations for video playback.

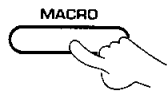
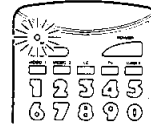
3 Terminate the setting operation.Press the **MACRO** key.**When the MACRO setting operation has been successful****When the MACRO setting has been unsuccessful**

The red indicator blinks twice.

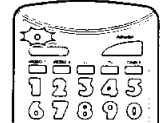
The red indicator lights for a few second and the **MACRO PLAY** mode is canceled. In this case, restart the procedure from the beginning.

Executing **MACRO PLAY**

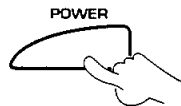
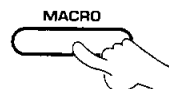
1 Load the video (or audio) software.**2 Switch ON the power of this unit.****3 Execute **MACRO PLAY**.****4 Operate each component as required.**

- Remove video (or audio) software from all other connected components.

- Be sure your video components are turned OFF when you press the **MACRO** key. If they are turned ON when you press the **MACRO** key, they will be turned OFF.

Set-up code list

KR-V8080/KR-V7080 (En)

VCR set-up code

Manufacturer	Set-up code
ADVENTURA	015
AIKO	293
AIWA	015
AKAI	056,064,068,076,257
AMERICAN HIGH	050
ASHA	255
AUDIOVOX	052
BEAUMARK	255
BELL & HOWELL	119
BROKSONIC	136,199,226,310,376
CALIX	052
CANON	050,182
CAPEHART	035
CARVER	096
CCE	087,293
CITIZEN	052,293
COLT	087
CRAIG	052,062,087,255,286
CURTIS MATHES	050,056,075
CYBERNEX	255
DAEWOO	035,060,102,293
DAYTRON	035
DYNATECH	015
ELECTROHOME	052
ELECTROPHONIC	052
EMEREX	047
EMERSON	015,017,052,058,076,136,199, 223,224,226,227,309,310,376
FISHER	062,069,081,119
FUJI	048,050
FUNAI	015
GARRARD	015
GE	050,075,080,217
GO VIDEO	247,294
GOLDSTAR	033,052,053
GRADIENTE	015
HARLEY DAVIDSON	015
HARMAN/KARDON	053,090
HARWOOD	087
HEADQUARTER	061

Manufacturer	Set-up code
HI-Q	062
HITACHI	056,057,080,097,120,181
JENSEN	056
JVC	023,056,082
KENWOOD	053,056,061,082
KLH	087
KODAK	050,052
LLOYD	015
LLOYD'S	223
LOGIK	087
LXI	052
MAGNAVOX	050,054,096,125,164
MAGNIN	255
MARANTZ	050,053,096
MARTA	052
MATSUSHITA	050
MEI	050
MEMOREX	015,050,052,054,061,062,063, 119,255
MGA	058,076
MGN TECHNOLOGY	255
MINOLTA	057,120
MITSUBISHI	058,076,082,090,188,229,257
MOTOROLA	050,063
MTC	015,255
MULTITECH	015,087
NAD	073
NEC	053,055,056,065,082,097
NIKKO	052
NOBLEX	255
OLYMPUS	050,241
OPTIMUS	052,063,073
OPTONICA	077
PANASONIC	050,092,177,240,241
PENNEY	050,052,053,055,057,069,255
PENTAX	057,080,120
PHILCO	050
PHILIPS	050,077,096,125
PILOT	052
PIONEER	073,082

VCR set-up code

Manufacturer	Set-up code
PORTLAND	035
PROTEC	087
PULSAR	054
QUARTER	061
QUARTZ	061
QUASAR	050,092
RADIO SHACK	015,052
RADIX	052
RANDEX	052
RCA	057,075,080,092,120,164,217
REALISTIC	015,050,052,061,062,063, 077,081,119,255
RICOH	049
RUNCO	054
SAMSUNG	060,068,255
SANKY	054,063
SANSUI	056,082,097,286
SANYO	061,062,119,255
SCOTT	058,060,136,199,225,226,227
SEARS	050,052,057,061,062,069,081, 119,120
SHARP	063,077
SHINTOM	087
SHOGUN	255
SHINGER	087
SONY	047,048,049,050
STS	057
SYLVANIA	015,050,058,096,125
SYMPHONIC	015
TATUNG	056
TEAC	015,056
TECHNICS	050,177
TEKNIKA	015,050,052,067
TMK	223,255
TOSHIBA	058,060,081,225,227
TOTEVISION	052,255
UNITECH	255
VECTOR	060
VECTOR RESEARCH	053,055
VIDEO CONCEPTS	055,060,076

Manufacturer	Set-up code
VIDEOSONIC	255
WARDS	015,050,057,062,063,077,087, 164,227,255
XR 1000	015
XR-1000	050,087
YAMAHA	053,056
ZENITH	048,049,054

31

LD set-up code

Manufacturer	Set-up code
AIWA	218
CARVER	079
DENON	187
FUNAI	218
KENWOOD	273
MAGNAVOX	232,256
MARANTZ	079
MITSUBISHI	074
NAD	074
PANASONIC	219
PHILIPS	079
PIONEER	074
QUASAR	219
RCA	366
REALISTIC	218
SHARP	016
SONY	208,216
YAMAHA	232

TV set-up code

Manufacturer	Set-up code
A-MARK	018
ABEX	047
ADMIRAL	108
ADVENTURA	061
AIKO	107
AKAI	045,113
ALARON	231
ALLERON	194,198
AMBASSADOR	192
ANAM	019,195
ANAM NATIONAL	070
AOC	018,034,045,067,152,200
ARCHER	018
AUDIOVOX	018,195
BELCOR	034
BELL & HOWELL	031,169
BRADFORD	195
BROCKWOOD	034
BROKSONIC	018
CANDLE	045,061,071,201
CAPEHART	067
CAPETRONIC	018,045
CARVER	069
CCE	232
CELEBRITY	015
CITIZEN	045,054,061,071,075,107,201, 295
CLAIRTONE	200
CONCERTO	071
CONTEC	173,195,200
CRAIG	195
CROWN	054,195
CURTIS MATHES	045,054,075,169
CXC	195
DAEWOO	034,054,106,107,466
DAYTRON	034,054
DUMONT	032,034
DYNATECH	064
ELECTROBAND	015,200

Manufacturer	Set-up code
EMERSON	034,053,054,169,173,192,193, 194,195,196,197,198,200,251, 285,295,297,478
ENVISION	045
FISHER	169,174
FUJITSU	194
FUNAI	194,195
FUTURETECH	195
GE	036,042,044,062,066,070,150, 189,193,297
GIBRALTER	032,034,045
GOLDSTAR	016,017,034,045,047,054,071, 121,193
GRUNPY	194,195
HALLMARK	193
HARVARD	195
HITACHI	047,053,071,110,112,160,166, 188,242
IMA	195
INFINITY	069
JANEIL	061
JBL	069
JCB	015
JENSEN	065
JVC	051,068,197
KAMP	231
KAWASHO	173,231,323
KAYPANI	067
KENWOOD	034,045
KLOSS	039,061
KMC	121
KTV	045,054,195,198,200,232,295
LOGIK	031
LUXMAN	071
LXI	062,069,163,169,171,193
MAGNAVOX	035,039,043,045,051,069,111, 201,202
MAJESTIC	031
MARANTZ	045,069

TV set-up code

Manufacturer	Set-up code
MATSUI	232
MEGATRON	018,160,193
MEI	200
MEMOREX	031,071,121,165,169,193
MGA	034,045,165,170,193
MIDLAND	032,047,054,062,066,150
MINUTZ	036
MITSUBISHI	034,113,165,170,193
MOTOROLA	070,108
MTC	034,045,064,071,075,106,200
MULTITECH	064,195, 232
NAD	171,181,193
NEC	034,045,051,071,185
NIKKO	045,107,193,332
NTC	107
ONWA	195
OPTIMUS	181
OPTONICA	108,180
ORION	251
PANASONIC	066,069,070,177,265,353
PENNEY	017,018,033,034,036,042,045, 047,054,062,066,075,125,150, 164,171,193
PHILCO	034,035,039,043,045,069,111, 201,202
PHILIPS	069
PILOT	034,045,054
PIONEER	053,181
PORTLAND	034,054,107
PRICECLUB	075
PRISM	066
PROSCAN	062
PROTON	018,046,067,193
PULSAR	032
PULSER	034
QUASAR	066,070,265
RADIO SHACK	034,047,054,180,195
RCA	033,034,044,053,062,105,150, 189

Manufacturer	Set-up code
REALISTIC	034,045,047,054,071,169,180, 193,195
RHAPSODY	198,200,231
RUNCO	032,045
SAMPO	045,047,054,067,115,125
SAMSUNG	034,045,047,054,071,075,125, 193
SAMSUX	054
SANYO	161,169,174
SCIMITSU	034
SCOTCH	193
SCOTT	034,193,194,195,251
SEARS	062,069,071,161,163,164,169, 171,174,186,193,194
SHARP	054,108,180
SHOGUN	034
SIGNATURE	031
SIMPSON	201,202
SONY	015,026,095,126,288
SOUNDESIGN	193,194,195,201
SPECTRICON	018,152
SQUAREVIEW	186
SSS	034,195
STARLITE	195
SUPRE-MACY	061
SUPREME	015
SYLVANIA	035,039,043,045,069,080,111, 201,202
SYMPHONIC	186
TANDY	108
TATUNG	018,064,070
TECHNICS	066,265
TECHWOOD	066,071
TEKNIKA	031,034,054,069,071,075,107, 165,194,195,201,327,337
TERA	046
TMK	071,192,193
TOSHIBA	051,075,164,169,171
TOSONIC	200

TV set-up code

Manufacturer	Set-up code
TOTEVISION	054
ULTRA	406
UNIVERSAL	036,042
VECTOR RESEARCH	045
VICTOR	068
VIDEO CONCEPTS	113
VIDIKRON	069
VIDTECH	034,193
VIKING	061
WARDS	031,034,035,036,042,043,044, 045,069,071,095,111,126,180, 189,193,194,202
YAMAHA	034,045
ZENITH	031,032
ZONDA	018

CABLE set-up code

Manufacturer	Set-up code
ABC	016,018,022,026,028,029,032,062
ANTRONIX	222
ARCHER	054,168,222
CENTURY	168
CITIZEN	168
COLOUR VOICE	040,046
COMBAND	247,248
COMTRONICS	055,075
CONTEC	034
EASTERN	017
ELECTRICORD	093
FOCUS	415
GARRARD	168
GC ELECTRONICS	222
GE	247,248
GEMINI	030,072,085,257
GENERAL INSTRUMENT	026,291
GOLDSTAR	055,159
HAMLIN	024,035,049,274,288
HITACHI	026
HYTEX	022
JASCO	168
JERROLD	018,026,027,029,030,039,062,113,291
MACOM	048
MAGNAVOX	042
MEMOREX	015
MOVIE TIME	078,093,171
NORTHCOAST	329
NSC	078,085,171
OAK	022,034,263
PANASONIC	036,122
PARAGON	015
PHILIPS	040,042,043,044,045,046,168,257,305
PIONEER	038,159,275
POPULAR MECHANICS	415
PULSAR	015

Manufacturer	Set-up code
RCA	036
REALISTIC	222
RECOTON	415
REGAL	035,274,288,294
REGENCY	017
REMBRANDT	026,085
RUNCO	015
SAMSUNG	055,159
SCIENTIFIC ATLANTA	021,023,032,292
SIGNAL	030,055
SIGNATURE	026
SL MARX	055
SPRUCER	036,322
STANDARD COMPONENTS	111
STARCOM	018,030,062,113
STARGATE	030,055
STARQUEST	030
SYLVANIA	016
TANDY	273
TATUNG	112
TEKNIKA	161
TELECATION	236
TELEVIEW	055
TEXSCAN	016,111
TOCOM	027,028,074
TOSHIBA	015
TUSA	030
TV86	078
UNIKA	168,222
UNITED ARTISTS	022
UNITED CABLE	018
UNIVERSAL	054,092,093,168,206,222,337
VIDEOWAY	265
VIDTECH	259
VIEWSTAR	042,075,078,226,273,304
ZENITH	015,069
ZENTEK	415

In case of difficulty

KR-V8080/KR-V7080 (En)

Operation to reset

The microcomputer may fall into malfunction (impossibility to operate, erroneous display, etc.) when the power cord is unplugged while power is ON or due to an external factor. In this case, execute the following procedure to reset the microcomputer and return it to normal condition.

While holding the REMOTE POWER key depressed, press the MAIN POWER key to ON.

- Please note that resetting the microcomputer clears the contents stored in and returns to the condition when it left the factory.

Amplifier

Symptom	Cause	Remedy
Sound is not output.	<ul style="list-style-type: none"> ● The speaker cords are disconnected. ● The VOLUME is set to the minimum position. ● MUTE is ON. (The MUTE ON indicator is blinking) ● The SPEAKERS keys are set to OFF. ● The TAPE 2(MONITOR) key is set to ON. 	<ul style="list-style-type: none"> ● Connect them properly referring to "System connection". - 6 ● Adjust the volume to a proper level. ● Press the MUTE key to OFF. - 15 ● Set the SPEAKERS key(s) to ON. - 12 ● Set the TAPE 2(MONITOR) key to OFF.
The STANDBY indicator blinks and sound is not output.	<ul style="list-style-type: none"> ● Speaker cords are short-circuited. 	<ul style="list-style-type: none"> ● Turn the power off, eliminate the short-circuiting, then turn on the power again. - 6
Sound is not output from one of the speakers.	<ul style="list-style-type: none"> ● The speaker cord is disconnected. ● The BALANCE control is set to an extreme position. 	<ul style="list-style-type: none"> ● Connect it properly referring to "System connection". - 6 ● Adjust the Left/Right balance. - 13
Sound is not output from the rear speaker and/or center speaker, or their sound is very small.	<ul style="list-style-type: none"> ● The rear-speaker cords and/or center speaker cord are disconnected. ● The Surround play mode has not been engaged. ● The REAR VOL. and/or CENTER VOL. controls are set to the minimum level. 	<ul style="list-style-type: none"> ● Connect them properly referring to "System connection". - 6 ● Set the presence mode. - 21 ● Adjust the REAR VOL. and CENTER VOL. controls. - 22
A hum noise is generated when the PHONO input is selected.	<ul style="list-style-type: none"> ● The audio cord from the turntable is not inserted securely into the PHONO jacks. ● The turntable is not grounded. 	<ul style="list-style-type: none"> ● Insert the audio cord plugs securely into the PHONO jacks. ● Connect the grounding wire to the GND terminal on the rear panel.

Tuner

Symptom	Cause	Remedy
Radio stations cannot be received.	<ul style="list-style-type: none"> ● No antenna is connected. ● The broadcast band is not set properly. ● The frequency of the desired station is not tuned. 	<ul style="list-style-type: none"> ● Connect an antenna. - 7 ● Set the broadcast band properly. - 17 ● Tune the frequency of the desired station. - 17
Interference.	<ul style="list-style-type: none"> ● Noise due to ignition noise of an automobile. ● Noise due to an influence from an electric appliance. ● Noise due to a nearby TV set. 	<ul style="list-style-type: none"> ● Install the outdoor antenna away from the road. ● Turn off the power to the appliance. ● Install the system farther away from the TV set.
A station which was preset cannot be received by pressing the corresponding numeric key.	<ul style="list-style-type: none"> ● The preset station belongs to a frequency that cannot be received. ● The preset memory was cleared because the power cord had been unplugged for a long period of time. ● The TUNER input is not selected. 	<ul style="list-style-type: none"> ● Preset a station with a receivable frequency. - 19 ● Preset the station again. - 19 ● Select the TUNER input.



Do not use contact cleaners because it could cause a malfunction. Be specially careful against contact cleaners containing oil, for they may deform the plastic components.

Audio section

Rated power output at the STEREO operation

100 watts per channel minimum RMS, both channels driven at 8 Ω, from 20 Hz to 20,000 Hz with no more than 0.06 % total harmonic distortion. (FTC)

Power output at the SURROUND operation

Front

100 watts per channel minimum RMS, both channels driven, at 8 Ω, 1 kHz with no more than 0.7 % total harmonic distortion. (FTC)

Center

100 watts minimum RMS at 8 Ω, 1 kHz with no more than 0.7 % total harmonic distortion. (FTC)

Rear

30 watts per channel minimum RMS, both channels driven, at 8 Ω, 1 kHz with no more than 0.7 % total harmonic distortion. (FTC)

Total harmonic distortion

0.01 % (1 kHz, 50 W, 8 Ω)

Signal to noise ratio (IHF'66)

PHONO (MM) 75 dB

LINE (CD) 95 dB

Input sensitivity / impedance

PHONO (MM) 2.5 mV / 47 kΩ

CD, TAPE, VIDEO 200 mV / 47 kΩ

Tone controls

BASS ± 8 dB (at 100 Hz)

TREBLE ± 8 dB (at 10 kHz)

LOUDNESS control at - 30 dB VOLUME level

+ 6 dB (100 Hz)

Output level / impedance

Sub woofer preout 1.0 V / 2.2 kΩ

Video section

VIDEO inputs / outputs (Composite) 1 Vp-p / 75 Ω

FM Tuner section

Tuning frequency range 87.5 MHz ~ 108 MHz

Usable sensitivity

MONO 1.2 μV (75 Ω) / 13.2 dBf
(75 kHz dev., S/N 30 dB)

50 dB quieting sensitivity

STEREO 32 μV (75 Ω) / 41.2 dBf
(75 kHz dev.)

Total harmonic distortion (1 kHz)

MONO 0.6 % (65.2 dBf input)

STEREO 0.7 % (65.2 dBf input)

Signal to noise ratio (1 kHz 75 kHz dev.)

MONO 75 dB (65.2 dBf input)

STEREO 68 dB (65.2 dBf input)

Stereo separation

1 kHz 40 dB

Selectivity (IHF ±400 kHz) 50 dB

Frequency response 30 Hz ~ 15 kHz, + 0.5 dB, - 3.0 dB

AM Tuner section

Tuning frequency range 530 kHz ~ 1,700 kHz

Usable sensitivity (30 % mod., S/N 20 dB)

12 μV / (500 μV / m)

Signal to noise ratio (30 % mod., 1 mV input) 48 dB

Total harmonic distortion 0.7 %

Selectivity 30 dB

General

Power consumption 4 A

AC outlet

SWITCHED 2: (total 65 W, 0.54 A max.)

Dimensions W:440 mm (17-5/16")

H:148 mm (5-13/16")

D:389 mm (15-5/16")

Weight (net) 10.2 kg (22.5 lb)



Specifications Other countries

⚠ **Caution** : Read this page carefully to ensure safe operation.

KR-VB080/KR-V7080 (En)

Audio section

Rated power output at the STEREO operation
1 kHz, 10 % THD at 8 Ω 120 W + 120 W
(DIN/IEC) from 63 Hz to 12,500 Hz,
0.7 % T.H.D., at 8 Ω 100 W + 100 W

Power output at the Surround operation
Front (1 kHz, 0.7 % T.H.D. at 8 Ω) ... 100 W + 100 W
Center (1 kHz, 0.7 % T.H.D. at 8 Ω) 100 W
Rear (1 kHz, 0.7 % T.H.D. at 8 Ω) 28 W + 28 W

Front (1 kHz, 10 % T.H.D. at 8 Ω) 120 W + 120 W
Center (1 kHz, 10 % T.H.D. at 8 Ω) 120 W
Rear (1 kHz, 10 % T.H.D. at 8 Ω) 30 W + 30 W

Total harmonic distortion (1 kHz, 8 Ω) 0.02 % at 50 W
Signal to noise ratio (IHF'66)
PHONO (MM) 75 dB
CD 93 dB

Input sensitivity / impedance
PHONO (MM) 2.5 mV / 47 kΩ
CD, TAPE, VIDEO 200 mV / 47 kΩ

Output level / impedance
Sub woofer preout 1.0 V / 2.2 kΩ

Tone controls
BASS ± 8 dB (at 100 Hz)
TREBLE ± 8 dB (at 10 kHz)
LOUDNESS control at - 30 dB VOLUME level
..... + 6 dB (100 Hz)

Video section

VIDEO inputs / outputs (Composite) 1 Vp-p / 75 Ω

FM Tuner section

Tuning frequency range 87.5 MHz ~ 108 MHz

Usable sensitivity
MONO 1.2 μV (75 Ω) / 13.2 dBf
(75 kHz dev., S/N 30 dB)

50 dB quieting sensitivity
STEREO 32 μV (75 Ω) / 41.2 dBf
(75 kHz dev.)

Total harmonic distortion (1 kHz)
MONO 0.6 % (65.2 dBf input)
STEREO 0.7 % (65.2 dBf input)

Signal to noise ratio (1 kHz 75 kHz dev.)
MONO 75 dB (65.2 dBf input)
STEREO 68 dB (65.2 dBf input)

Selectivity (IHF ± 400 kHz) 50 dB
Stereo separation (IHF at 1 kHz) 40 dB
— **Frequency response ... 30 Hz ~ 15 kHz, + 0.5 dB, - 3.0 dB**

AM Tuner section

Tuning frequency range
9 kHz 531 kHz ~ 1,602 kHz
10 kHz 530 kHz ~ 1,610 kHz

Usable sensitivity (30 % mod., S/N 20 dB)
..... 12 μV / (500 μV / m)

Total harmonic distortion 0.7 %
Signal to noise ratio (30 % mod., 1 mV input)
..... 48 dB

Selectivity 30 dB

General

Power consumption 330 W
AC outlet
SWITCHED Australia : 1 (100 W max.)
China : 2 (total 90 W max.)
Other countries : 2 (total 100 W max.)

Dimensions W: 440 mm
H: 148 mm
D: 389 mm

Weight (net) 10.2 kg



KENWOOD follows a policy of continuous advancements in development. For this reason specifications may be changed without notice.

For the U.S.A.

FCC WARNING

This equipment may generate or use radio frequency energy. Changes or modifications to this equipment may cause harmful interference unless the modifications are expressly approved in the instruction manual. The user could lose the authority to operate this equipment if an unauthorized change or modification is made.

NOTE:

This equipment has been tested and found to comply with the limits for a Class B digital device, pursuant to Part 15 of the FCC Rules. These limits are designed to provide reasonable protection against harmful interference in a residential installation. This equipment may cause harmful interference to radio communications, if it is not installed and used in accordance with the instructions. However, there is no guarantee that interference will not occur in a particular installation. If this equipment does cause harmful interference to radio or television reception, which can be determined by turning the equipment off and on, the user is encouraged to try to correct the interference by one or more of the following measures:

- Reorient or relocate the receiving antenna.
- Increase the separation between the equipment and receiver.
- Connect the equipment into an outlet on a circuit different from that to which the receiver is connected.
- Consult the dealer or an experienced radio / TV technician for help.

For the U.S.A.

Note to CATV system installer:

This reminder is provided to call the CATV system installer's attention to Article 820-40 of the NEC that provides guidelines for proper grounding and, in particular, specifies that the cable ground shall be connected to the grounding system of the building, as close to the point of cable entry as practical.

KENWOOD

For your records

Record the serial number, found on the back of the unit, in the spaces designated on the warranty card, and in the space provided below. Refer to the model and serial numbers whenever you call upon your dealer for information or service on this product.

Model _____ Serial Number _____