

Wireless LAN Access Point ***NE-W01E***

Instruction Manual

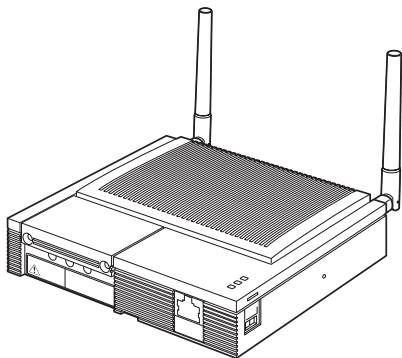

Preface

This manual describes how to install and connect the Wireless LAN Access Point NE-W01E.

To ensure full use of the Wireless LAN Access Point NE-W01E, be sure to thoroughly read this manual, and fully understand the functions of the NE-W01E before use. Store this manual in a safe place so that you can retrieve it whenever necessary.

■ Symbols

This manual uses the following symbols to alert you to important information.



Failure to follow these instructions may lead to death or serious injury.



Failure to follow these instructions may lead to injury.



Failure to follow these instructions may lead to physical damage (product malfunction, etc.).

Important: Provides additional information on precautions and restrictions that must be followed in operation.

Note: Provides additional information on proper operation.

[Tip]

Indicates useful information or information that aids understanding of text descriptions.

 Indicates a reference item or page to be referred to in this manual and a separate manual.

■ Request

- (1) No part of this instruction may be reprinted or reproduced without the prior written permission of KEYENCE CORPORATION.
- (2) The contents of this manual are subject to change without notice.
- (3) Every effort has been made in preparing this document. If, however, you find any unclear points, errors, omissions or other inconsistencies, please feel free to contact us.
- (4) Note that KEYENCE CORPORATION shall not be liable for any influence resulting from operation of the Wireless LAN Access Point NE-W01E regardless of item (3) above.
- (5) We shall replace any missing or incorrectly collated pages.

■ How This Manual Is Organized

This manual briefly describes this product and describes the procedure from installation through to connection. Proceed with work by following the procedure illustrated below.

Dotted lines indicate parts described in this manual.

Before you start to use your NE-W01E

Safety Precautions (page 2)
Operating Environment (page 7)

Check the functions of the NE-W01E.
Features and Functions of the NE-W01E (page 9)
Examples of Networks Built Using the NE-W01E (page 10)



Checks and preparations before you install your NE-W01E

Checking the Contents of the Package (page 12)
Names of Parts (page 13)



Installing your NE-W01E

Installing the NE-W01E (page 15)
Power Connection and Ground (page 21)



Setting up your NE-W01E

Set up your NE-W01E.
For details, refer to the "User's Manual" (PDF).



Maintenance and troubleshooting are described in this manual.
Read these sections if necessary.

Maintenance

Periodic Maintenance and Inspection (page 23)
Precautions When Replacing the Body (page 23)



Troubleshooting

Read this section if you think that your NE-W01E is malfunctioning as a result of a hardware problem.
Troubleshooting (page 23)

Safety Precautions

■ General Precautions

- At startup and during operation, be sure to monitor the functions and performance of the NE-W01E.
- We recommend that you take substantial safety measures to avoid any damage in the event that a problem occurs.
- Do not modify the NE-W01E or use it in any way other than described in the specifications. The functions and performance of products used or modified in this way cannot be assured.
- When the NE-W01E is used in combination with other equipment, functions and performance may be degraded depending on operating conditions, surrounding environment and other factors. Fully take this into consideration before using the NE-W01E in this way.
- Do not subject instruments including peripheral devices to sudden changes in temperature. Doing so might cause condensation which may cause the instrument or device to malfunction.
- Mount the NE-W01E as far away as possible from power lines or high-voltage lines. Noise from power lines and high-voltage lines may cause the NE-W01E to malfunction.
- NE-W01E is not a general purpose equipment suitable for use by the average consumer.
- NE-W01E is not a product safe to use for domestic use.
- NE-W01E has reduced safety features and must only be used under specific environmental conditions.
- NE-W01E has reduced safety features and product must only be used by technically skilled persons.

Do not use the NE-W01E near the following items:

● Medical equipment such as pacemakers

The NE-W01E might cause electrical interference with medical equipment or pacemakers, and endanger human life.

● Microwave ovens and other electronic household items, in-site wireless nodes (requiring a license) for mobile recognition that are used in factory production lines, etc., and specific small-power wireless nodes (not requiring a license)

The NE-W01E might cause electrical interference, resulting in a drop in communications speed, loss of data or diminished transfer distance.

Should radio wave interfere with in-site wireless modes for mobile recognition and specific small-power wireless nodes be generated from the NE-W01E, change the frequency of the NE-W01E to prevent radio wave interference from occurring.

Use cellphones, PHS, TVs or radios as far away as possible from the NE-W01E.

Noise is sometimes generated in voice or video images due to the influence of radio waves generated by wireless LAN products.

DANGER

- *Do not lay cables during lightning. Lightning may cause electric shock.*
- *Do not build a network using this device that may adversely affect human life or damage equipment.*

CAUTION

- *Do not touch the Ethernet ports with a pen, screwdriver or other fine-tipped object. Doing so might scratch or damage the Ethernet ports.*
- *Do not subject this device to impact, or exert more than necessary force when inserting the STP/UTP cables into the Ethernet ports. Doing so might damage the Ethernet ports.*
- *Do not wipe this device with paint thinner or organic solvents. Doing so might damage this device. When wiping this device, use a soft cloth moistened with watered down neutral detergent.*
- *Do not drop this device, bump it or subject it to strong impact. Doing so might damage this device.*

■ Requests

If the NE-W01E is to be used in the following conditions or environments, make sure that the actual operating conditions are well within the published ratings and functional parameters. Take all necessary safety precautions, such as ensuring that operation is fail-safe. Also, consult your agent about the following applications.

- Use under conditions and environment not described in this manual
- Use of the NE-W01E in nuclear power control, railroad facilities, aircraft facilities, vehicles, combustion units, medical instruments, amusement machines, and safety devices
- Use in applications where a major influence to human life and property is anticipated, and where safety in particular is required

■ Precautions for UL Certificate

The NE-W01E complies with the UL standard and has UL/C-UL certificate under the following details.

- Applicable standard UL508 Industrial Control Equipment
 CAN/CSA C22.2 No. 14-M95 Industrial Control
 Equipment
- UL File No. E195940
- UL Category NMTR, NMTR7



<Precautions>

- Be sure to use electrical wire that conform to the following conditions for wiring to the terminal block, and tighten the electrical wire by a tightening torque of 0.7 Nm:

Wire range	AWG14-12
Wire material	Copper only
Wire type	Stranded only
Rated temperature	60°C or more

- After wiring to the terminal block is completed, be sure to close the terminal block cover. Also, never open the terminal block cover when the NE-W01E is turned ON.

Precautions for FCC

The NE-W01E falls under the category of intentional radiowave-emitting devices stipulated in FCC Part 15 subpart C. Keyence Corporation has evaluated compliance with the requirements of FCC Part 15 subpart C, and has confirmed that the NE-W01E satisfies those requirements.

This equipment has been tested and found to comply with the limits for a Class B digital device, pursuant to Part 15 of the FCC Rules. These limits are designed to provide reasonable protection against harmful interference in a residential installation. This equipment generates, uses and can radiate radio frequency energy and, if not installed and used in accordance with the instructions, may cause harmful interference to radio communications. However, there is no guarantee that interference will not occur in a particular installation. If this equipment does cause harmful interference to radio or television reception, which can be determined by turning the equipment off and on, the user is encouraged to try to correct the interference by one or more of the following measures:

- Reorient or relocate the receiving antenna.
- Increase the separation between the equipment and receiver.
- Connect the equipment into an outlet on a circuit different from that to which the receiver is connected.

Consult the dealer or an experienced radio/TV technician for help.

You are cautioned that changes or modifications not expressly approved by the party responsible for compliance could void your authority to operate the equipment.

The NE-W01E cannot be used with a device other than the antenna (provided) mounted. When the NE-W01E is replaced, for example, due to antenna damage, be sure to purchase and mount an antenna exclusively for the NE-W01E.







<RF exposure information>

This device complies with FCC RF radiation exposure limits set forth for an uncontrolled environment. The antenna used for this transmitter must be installed to provide a separation distance of at least 20 cm from all persons and must not be co-located or operating in conjunction with any other antenna or transmitter.

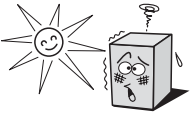
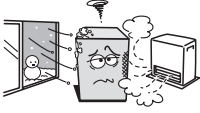
Operating Environment

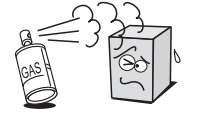
■ Installation location

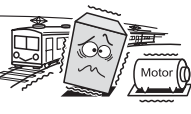
Do not install the NE-W01E in the following locations.

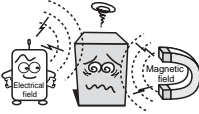
Locations subject to direct sunlight	Locations subject to ambient temperature out of the 0 to +50°C range	Locations subject to ambient humidity out of the 35 to 80%RH range
		
Locations subject to condensation caused by sudden temperature change	Locations subject to corrosive and flammable gases	Locations subject to large amounts of dirt and dust, salt, iron and oil smoke
		
Locations directly subject to vibration and shock	Locations that may be splashed with water, oil or chemical mist	Locations where strong magnetic and electrical fields are generated
		

Note: Install the NE-W01E as far away as possible from locations where radios, etc. are located. Radio waves emitted by the NE-W01E may cause noise to occur on the radio.

■ Installation location precautions

Pay attention to the following points when installing the NE-W01E.

- Do not install the NE-W01E in a location where the ambient temperature exceeds the 0 to +50°C range or the ambient humidity exceeds the 35 to 80%RH range.
- If the ambient temperature exceeds the above range, install a forced air cooling fan or air conditioner to keep the ambient temperature within this range.
- Allow as much space as possible between the NE-W01E and surrounding structures and other components to improve maintainability, operability and ventilation.
- Do not mount the NE-W01E directly above equipment (e.g. heaters, transformers, inverters and equipment with large resistance) that generate lots of heat.

■ Measures for improving noise resistance

- Do not mount the NE-W01E inside industrial control panels in which high-voltage devices are also located.
- Mount the NE-W01E as far away as possible from power lines.
- Mount the NE-W01E as far away as possible when it must be mounted next to devices (e.g. solenoids, choppers, etc.) that generate strong magnetic and electrical fields.
- Do not include the NE-W01E I/O leads in the same ducts as power lines and high-voltage lines. Wire the I/O leads in separate ducts. Noise from power lines and high-voltage lines may cause malfunction on the NE-W01E.
- On the NE-W01E that is provided with an earth terminal and shielded leads, provide a class D earth (maximum resistance of 100 Ohms).

Features and Functions of the NE-W01E

Wireless LAN Access Point NE-W01E is an access point for wireless LAN communications that is compliant with IEEE802.11b.

■ IEEE802.11b compliant

NE-W01E is compliant with the IEEE802.11b standard , and is capable of high-speed wireless communications of 11 Mbps (logical value).

■ Wiring by cables is no longer required, allowing the configuration of a wireless network.

Wiring by conventional network cables is no longer required. This allows you to install PCs and other wireless LAN devices as you like.

■ Integrated security functions

Data is encrypted by the WEP (Wired Equivalent Privacy) function to protect valuable data. (64-bit WEP and 128-bit WEP modes are supported.)

Examples of Networks Built Using NE-W01E

A wireless LAN network can be built by combining NE-W01E with Wireless LAN Station NE-W11E. Wireless LANs operate in two communications modes: infrastructure mode and ad-hoc mode. When NE-W01E is combined with these products to build a network, configure the network in the infrastructure mode.

Note: The NE-W01E cannot be used in networks configured in the ad-hoc mode.

■ Example of a network built in the infrastructure mode

In relatively large-scale networks where the user wants to add on a wireless LAN network to an existing wired LAN network or access the Internet from a wireless LAN network, access points are used to configure a network in the infrastructure mode.

● Example 1

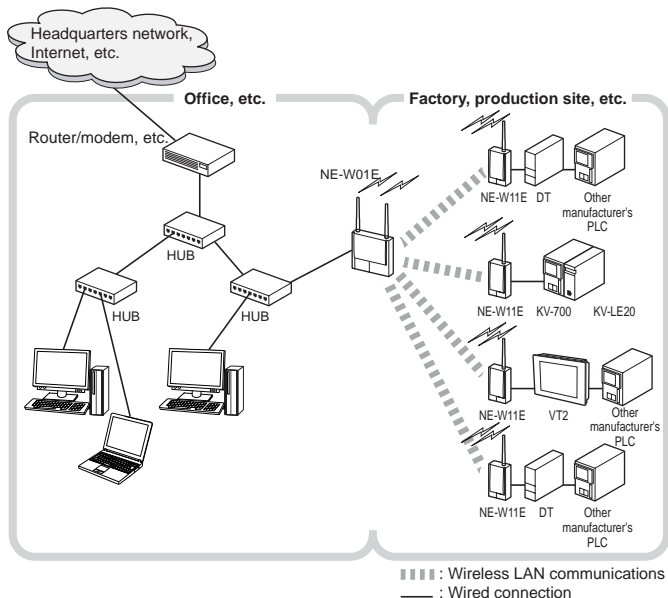

● Example 2

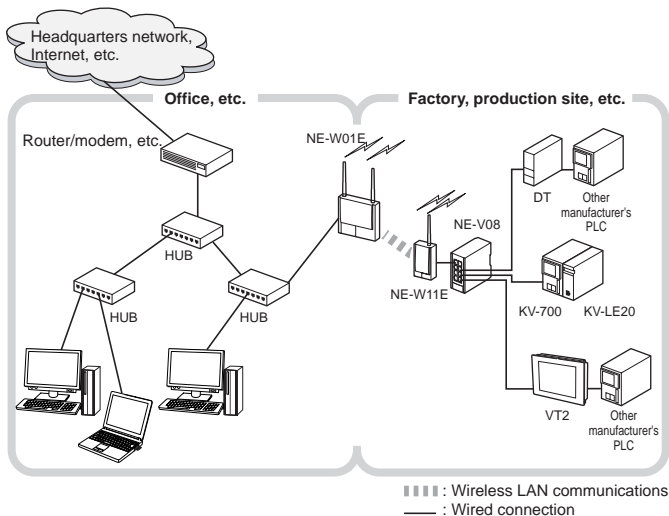

Checking the Contents of the Package

The package contains the following items. Before you start using the NE-W01E, make sure that the package contains everything that it is supposed to contain.

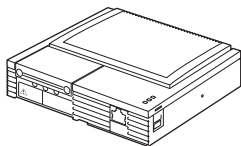

NE-W01E body

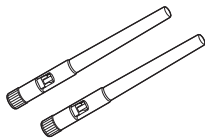

Antennas (2 pcs)

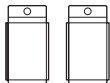

Magnets
(2 pcs, mounted on body)



Magnet mounting screws
(2 pcs, mounted on body)



Wall-mounting screws
(3 pcs)

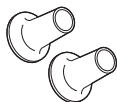

Rubber caps (2 pcs)

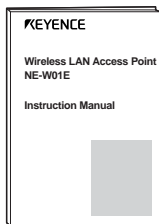

Instruction Manual (this manual)

Every effort has been made preparing this package. If, however, some of the parts are defective or broken, contact our dealer.

Names of Parts

■ Front view

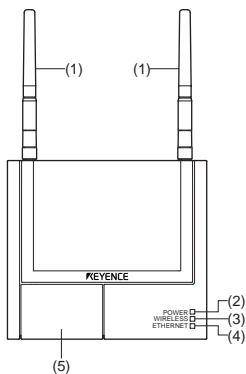

■ Rear view

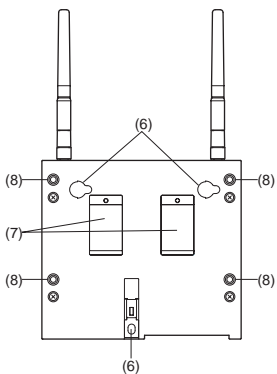



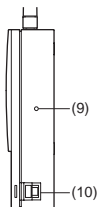

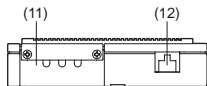

■ Side view



■ Bottom view



Name	Description
(1) Antenna	Antenna (2 pcs)
(2) POWER LED (green)	This LED lights (green) when the unit is energized.
(3) WIRELESS LED (green)	<p>This LED indicates the state of wireless LAN communications.</p> <p>Lit: The wireless LAN link is established.</p> <p>Blinking: Communications is in progress.</p> <p>Out: The wireless LAN link is not established.</p>
(4) ETHERNET LED (green)	<p>This LED indicates the state of the Ethernet port.</p> <p>Lit: The link with the destination device is established.</p> <p>Blinking: Data communications is in progress.</p> <p>Out: Either the cable is not connected, or the link is not connected.</p>
(5) Power supply terminal block cover	<p>This cover protects the power supply terminal block.</p> <p>( "How to open the power supply terminal block cover" page 21)</p>
(6) Wall-mounting screw holes	<p>These three holes are for hooking the wall-mounting screws after the screws have been fixed on the wall when the body is to be wall-mounted.</p> <p>( "Installing the NE-W01E" page 15)</p>
(7) Magnet	<p>This magnet is for fastening the body in place.</p> <p>( "Installing the NE-W01E" page 15)</p>
(8) M3 mounting screws	<p>These 4 holes are used for fastening the body in place with the M3 screws.</p> <p>( "Installing the NE-W01E" page 15)</p>
(9) Initialize switch	<p>This switch is used to return setting values to their defaults (factory settings).</p> <p> "Defaults (factory settings)" (page 26)</p>
(10) Straight/cross selector switch	<p>This switch is for selecting straight or cross connections.</p> <p> : Straight</p> <p>X: Cross</p>
(11) Power terminal block	<p>This terminal block is for 100 to 240 VAC input power.</p> <p>( "Power terminal diagram" page 21)</p>
(12) Ethernet port	This is a 10Base-T (MDI/MDI-X procedure selection) Ethernet port.

Installing the NE-W01E

■ Installation location

- Read "Safety Precautions" (☞ page 2) in this manual, and check the precautions when using the NE-W01E.
- Read "Operating Environment" (☞ page 7) in this manual, and check the precautions regarding the installation location. The NE-W01E uses radio waves. So, sometimes normal communications is no longer possible in some operating environments.
- Make sure that the NE-W01E is not installed too far away from other wireless LAN devices, and that there are no obstacles (metal, concrete walls, etc.) in between these wireless LAN devices. Transmission speed and transfer distance fluctuate considerably depending on the ambient environment.
- Install the NE-W01E in locations where there is a clear path between the NE-W01E and other wireless LAN devices. We recommend installing the Wireless LAN Station NE-W11E within a radius of 20 m of the NE-W01E at their center as shown in the figure below.

(The standard distance for indoor communications is roughly 40 m.)

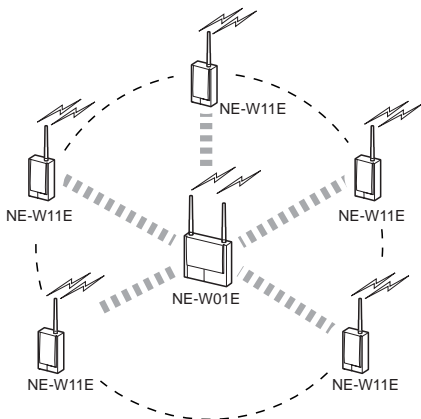

- * We recommend limiting the number of devices connected to the NE-W01E to eight devices.

● Distance between surrounding areas

Be sure to allow at least 30 mm of space between the NE-W01E and other devices or surrounding walls when installing the NE-W01E.

■ Attaching the antennas

1 Attach the rubber caps onto the antennas (provided).

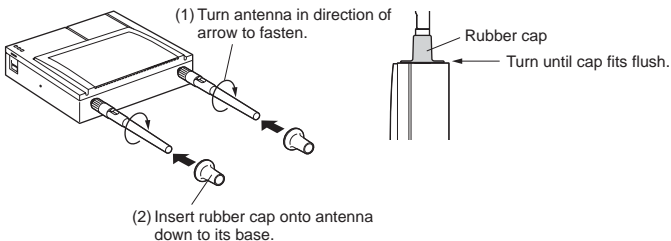

2 Adjust the orientation of the antennas.

Adjust the orientation of the antennas of each wireless LAN device so that the antennas are parallel with each other. To adjust the orientation, turn the antennas in the clockwise direction.

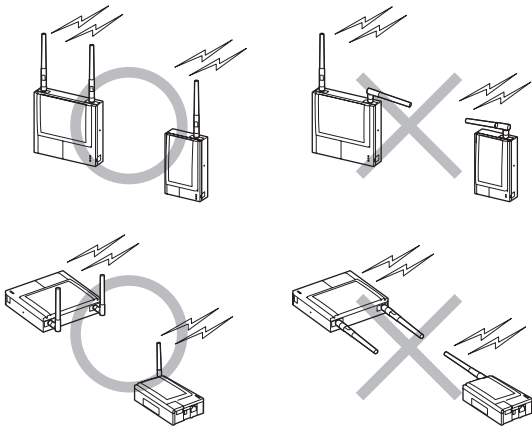

■ Installing the NE-W01E

The NE-W01E can be installed on flat surfaces such as desktops, on vertical surfaces such as walls, and on ceilings. Select the mounting method according to the environment where you will be using NE-W01E:

- Magnet mount
- Screw mount
- Wall mount

● Magnet mount

Mount the NE-W01E by the magnets on the back of the NE-W01E. This mounting method is advantageous as it allows the NE-W01E to be fastened on horizontal surfaces such as desktops, and vertical and slanted surfaces, and moved as you like.

⚠ CAUTION

- *When mounting the NE-W01E by the magnets, avoid using the NE-W01E at locations subject to lots of vibration.*
- *Do not attach the magnets near products such as floppy disks that are likely to be affected by magnetism.*
- *Sliding the body while it is attached to a steel desk or control panel by the magnets may scratch painted surfaces.*

● Screw mount

1 Unscrew the magnets on the rear of the NE-W01E body.

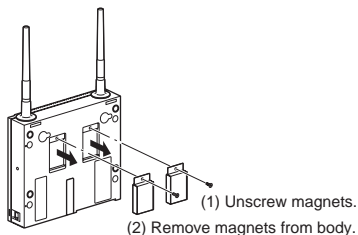

Note: When re-attaching the magnets after you have removed them from the NE-W01E body, tighten the screws that hold the magnets in place with a torque of 0.4 Nm {4 kgf•cm}.

- 2** Check the positions of the four screw holes, and drill holes for screw fastening at the location (panel, etc.) where the NE-W01E body is to be installed.

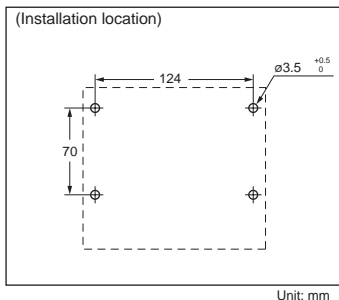

- 3** Align the position of the screw-fastening holes with the rear of the NE-W01E body, and fasten the four locations with the screws.

Tighten the screws with a torque of 0.4 Nm {4 kgf•cm}.

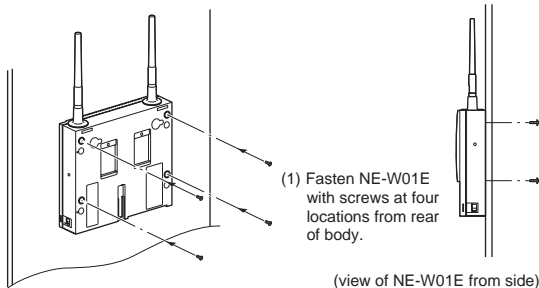

CAUTION

The depth of the screws provided with the NE-W01E is 5 mm. Use screws of a length that takes into consideration the thickness of the installation location (panel, etc.). Long screws might damage the NE-W01E body.

● Wall mount

- 1 Remove the magnets on the rear of the NE-W01E body. Slide the wall-mounting fixture downwards.

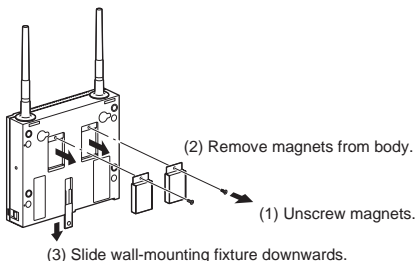

Note: When re-attaching the magnets after you have removed them from the NE-W01E body, tighten the screws that hold the magnets in place with a torque of 0.4 Nm {4 kgf•cm}.

- 2 Attach two of the wall-mounting screws (provided) at the location (wall, etc.) where the NE-W01E is to be installed.

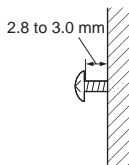
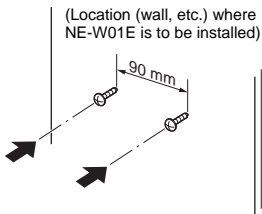

(view of NE-W01E from side)

- 3** Align and hook the screw holes on the rear of the NE-W01E body onto the screws on the wall. Slide the body slightly to the right to prevent it from falling from the wall.

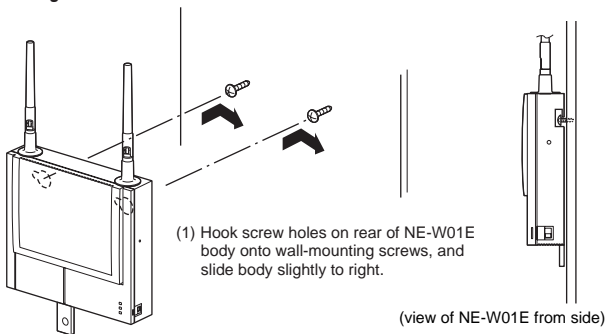

- 4** Attach the remaining wall-mounting screws in the holes of the wall-mounting fixture, and fasten the body firmly against the wall.

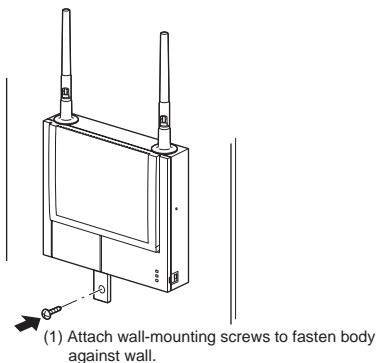

Power Connection and Ground

■ How to open the power supply terminal block cover

The power terminal block on the NE-W01E is protected by a cover. When connecting the power supply, open this cover by the following procedure.

- 1 Use a screwdriver to loosen the two screws fastening the cover.
- 2 Slide the cover in the direction of the arrow, and open the cover upwards as it is.

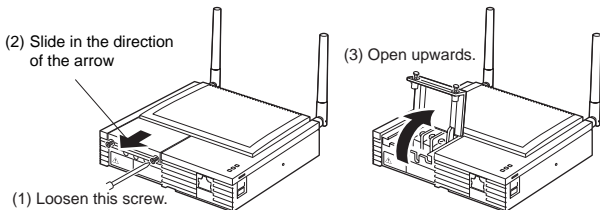

⚠ CAUTION

Be sure to close the power terminal block cover before you start to use the NE-W01E. The procedure for closing the cover is opposite that for opening the cover.

Tighten the screws on the power terminal block cover with a torque of 0.2 Nm {2 kgf•cm}.

■ Power terminal diagram

The power terminal is located inside the power terminal block when the cover is opened. The NE-W01E is not provided with a power switch. Note that the NE-W01E starts to operate when power is supplied to the power terminal block.

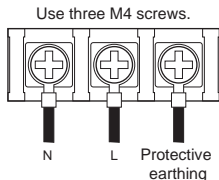

● Terminal specifications

Item	Description
Wire size	AWG14-12
Tightening torque	0.7 Nm (7 kgf•cm)
Wire material	Copper
Wire type	Stranded
Rated lead temperature	+60°C

⚠ DANGER

Do not remove the power terminal with the NE-W01E power ON. Doing so might cause electric shock.

■ When using crimped terminals

Use crimped terminals that conform to the following shapes and dimension.



NE-W01E
a: 8 mm max.

■ Wiring

Connect the 100 to 240 VAC (10% power supply to the power supply input terminal as follows:

100 to 240 VAC $\pm 10\%$ (50/60 Hz)



■ Grounding precautions

The following describes the precautions to follow when grounding the NE-W01E.

- Provide an exclusive ground of class D earth (maximum resistance of 100 Ohms) when grounding the shielded lead on the earth terminal.
- If an exclusive ground cannot be obtained, share the ground with another device.

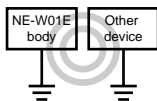

Class D earth
Max. resistance of 100 Ω

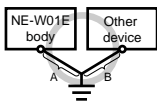

A=B
Class D earth
Max. resistance of 100 Ω

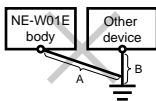

A > B
A < B

- Use a grounding cable having a nominal cross-sectional area of 2 mm² or more.
- Keep the grounding point as close as possible to the NE-W01E, and keep the ground lead as short as possible.
- If the ground lead must be extended, use thick insulating lead, and pass the lead through a duct before grounding.
- If grounding appears to make the NE-W01E malfunction, separate the ground lead from the shielded lead of the protective ground terminal.

Periodic Maintenance and Inspection

■ Maintenance

- Inspect the NE-W01E once every six months to one year. Inspect the NE-W01E at shorter inspection periods if it is used in extremely high-temperature and/or high-humidity or dusty environments.
- If you cannot remove dirt or dust on the NE-W01E by wiping with a soft, dry cloth, wipe with a firmly wrung cloth moistened with watered down neutral detergent.
- If rubber, vinyl products or adhesive tape are left attached to the NE-W01E for a long period of time, the NE-W01E may become stained. Remove any of these during cleaning if attached to the NE-W01E.

Inspection Item		Inspection Standard
Power supply	Voltage fluctuations on power terminal	Voltage fluctuation must be within the allowable range. 100 to 240 VAC \pm 10% (50/60 Hz)
Ambient environment conditions	Ambient temperature	Must be within the operating ambient temperature range. 0 to +50°C
	Ambient humidity	Must be within the operating ambient humidity range. Max. 80%RH
	Dust, dirt, etc.	Dirt or dust is not allowed to accumulate.
Mounting conditions	State of LAN cables	The connector must be completely inserted and must not be loose.
	LAN cable connections	The LAN cable must free from abnormalities such as broken leads.
	Loose screws	The power terminal block, antenna and mounting screws must not be loose.

Precautions When Replacing the Body

Pay attention to the following points when replacing the body:

- Turn the power OFF before you replace the body.
- After replacing the body, check the new body for any abnormalities.
- If a nonconformity necessitates that the body be repaired, send the body back to your Keyence agent attached with a sheet of paper described the circumstances in which the nonconformity occurred in as much detail as possible.

Troubleshooting

● The POWER LED does not light.

- Make sure that the power terminal is connected correctly to the power supply terminal block.
- Swap the power supply with a different power supply and check again.

● The ETHERNET LED does not light.

- Make sure that the cables are firmly inserted.
- Try switching the straight/cross selector switch to see if the ETHERNET LED lights.
- Make sure that the devices that are connected to the Ethernet port are ON.
- Make sure that the cable connected to the Ethernet port is a cable of the correct type.
- Check the cables for any breaks using a cable tester or similar device.

Specifications

■ General specifications

Item	NE-W01E			
Power supply voltage	100 to 240 VAC \pm 10% (50/60 Hz)			
Current consumption	10 VA max.			
Overvoltage category	II			
Ground	Class D earth (max. resistance of 100 Ω)			
Operating ambient temperature	0 to +50°C (freezing not allowed)			
Storage temperature	-20 to +70°C			
Operating ambient humidity	35 to 80%RH (condensation not allowed)			
Storage humidity	35 to 80%RH (condensation not allowed)			
Pollution degree	2			
Withstand voltage	1500 VAC for 1 minute (across power supply terminal and I/O terminals, and across all external terminals and case)			
Insulating resistance	5 M Ω or more (across power supply terminal and I/O terminals, and across all external terminals and case by 500 VDC megger)			
Vibration resistance	Frequency	Acceleration	Amplitude	Number of sweeps
	10 to 57 Hz	—	0.075 mm	10 times in each of X, Y and Z directions (for 80 minutes)
	57 to 150 Hz	9.8 m/s ²	—	
Ambient atmosphere	Excessive dirt, dust or corrosive gas not allowed			
Weight	Approx. 470 g			
Applicable standards	CE, UL, FCC, Wireless Telegraphy Act			

■ Functional and performance specifications

Item	NE-W01E
Power input	By terminal block (L, N, F.G.)
Communications port	Wired: 10Base-T (MDI/MDI-X procedure selection)* Wireless: IEEE802.11b
Antenna	2 (diversity antenna)
Reset switch	For initializing setting values
Structure	Magnet mount Screw mount Wall mount

* STP/UTP (Category 3 or higher) compatible

■ Wireless LAN specifications

Item	NE-W01E
Data transmission rate	1/2/5.5/11 Mbps (automatically selected)
Network standard	IEEE802.11b
Frequency band	2.4 GHz
Network architecture	Infrastructure mode
Transmission system	DS-SS (Direct Sequence Spread Spectrum)
Modulation system	DBPSK (at 1 Mbps) DQPSK (at 2 Mbps) CCK (at 5.5/11 Mbps)
Number of connection channels	11
Transmission distance*1	Open areas: Approx. 200 m Indoors: Approx. 40 m
Encryption	WEP 64/128 bit
MAC address filtering	Max. 16 units can be registered.
Max. number of connections	200 units (stations)*2

*1 Transmission distance is a logical value. The actual transmission distance varies according to the environment you are operating in.

*2 Eight or less units is recommended.

■ Ethernet port I/O specifications

Pin assignment table (Ethernet)



RJ-45 modular connector

* View from outside of NE-W01E

Pin No.	MDI	MDI-X
1	TD+	RD+
2	TD-	RD-
3	RD+	TD+
4	-	-
5	-	-
6	RD-	TD-
7	-	-
8	-	-

RD: Receive data TD: Send data

Item	NE-W01E
Compliant standard	IEEE802.3
Baud rate	10 Mbps
Transmission medium	STP/UTP (Category 3 or higher)

■ Defaults (factory settings)

These are the settings that are set on the NE-W01E before it is shipped from the factory.

Item	Setting Value
Unit name	NE-W01E
Password	None
IP setting mode	Fixed
IP address	192.168.0.13
Subnet mask	255.255.255.0
Gateway address	0.0.0.0
ESSID	KeyenceWLAN
Channel	1
Encryption (WEP)	OFF

■ MAC addresses

A "MAC address" is a unique address that is assigned to each individual device, and comprises six bytes or 48 bits. MAC addresses cannot be changed by the user as they are programmed to the NE-W01E. The MAC address programmed to the NE-W01E is written on the product label on the side of the body.

External Dimensions

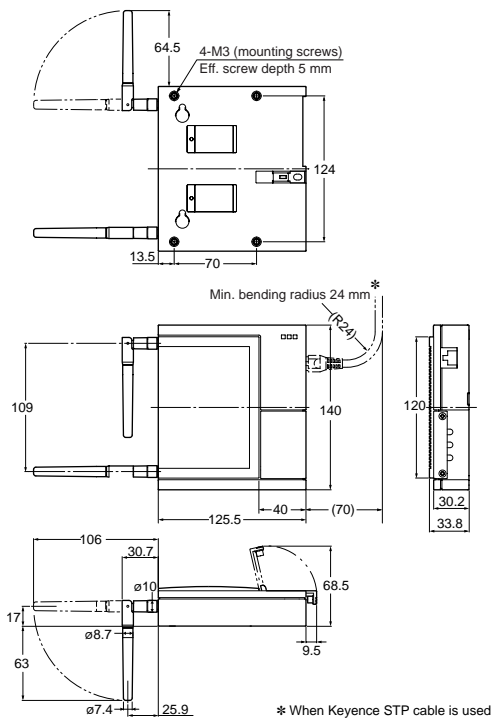

■ Expanded view when rubber caps are attached

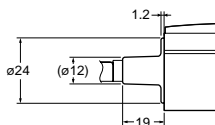

Unit: mm

■ Magnet mounting diagram

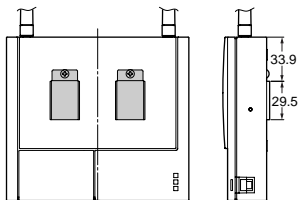
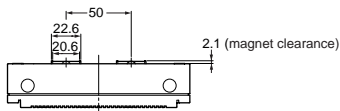

(front perspective)

■ Wall mounting diagram

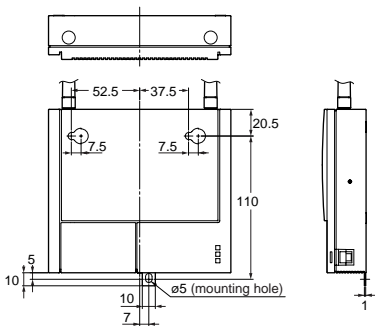

(front perspective)

Warranty

1. Warranty Period

The warranty period for this product shall be one year from the date of purchase at the specified location.

2. Scope of Warranty

(1) If a malfunction due the liability on the part of KEYENCE CORPORATION arises during the above warranty period, this product shall be repaired free of charge. However, instances that fall under the following categories shall be excluded from the scope of warranty:

- (1) Malfunctions due to inappropriate conditions, environment, handling, and method of use other than described in the operation manual, user's manual, and other separately exchanged specifications, etc.
- (2) Malfunctions due to a cause other than a KEYENCE CORPORATION product such as a customer's device or software design
- (3) Malfunctions due to remodeling and repair other than KEYENCE CORPORATION
- (4) Malfunctions recognized as being preventable if consumables listed in the operation manual and user's manual, for example, are maintained and replaced correctly
- (5) Malfunctions due to unforeseen causes in scientific and technical standards before shipment
- (6) Other malfunctions due to fire, earthquake, water damage, and other disasters, and external factors such as abnormal power voltage that are not the liability of KEYENCE CORPORATION

(2) (1) above shall be set as the restriction for the scope of warranty, and secondary damages (damage to devices, mechanical loss, profit due to defects, etc.) on the part of the customer due to malfunction of a KEYENCE CORPORATION product and any other damages whatsoever shall be outside the scope of warranty.

3. Scope of Application of This Product

KEYENCE CORPORATION products are designed and manufactured as general-purpose equipment for general industrial applications. Use in applications such as nuclear power generation, aircraft, railways, and medical equipment, for example, where excessive influence is expected on human life and property shall be outside of the scope of application of this product. Note, however, that use of this product in applications where the user has understood the specifications of this product after prior consultation with KEYENCE CORPORATION shall be within the scope of application of this product. (Even in this instance, the scope of application of this warranty shall be the same as described above.)

KEYENCE

KEYENCE CORPORATION

1-3-14, Higashi-Nakajima, Higashi-Yodogawa-ku,
Osaka, 533-8555, Japan

PHONE: +81-6-6379-2211 FAX: +81-6-6379-2131