

EN IMPORTANT: Keep these instructions. DO NOT DISCARD.

Caution:

Please read these carefully before using:

1. Only adults should install and replace batteries.
2. Rechargeable batteries are only to be charged under adult supervision.
3. Rechargeable batteries are to be removed from the toy before being charged.
4. Non-rechargeable batteries are not to be recharged.
5. If the device has not used for a long time, remove the batteries.
6. Do not mix old and new batteries.
7. Do not mix alkaline, standard (carbon zinc) or rechargeable (nickel cadmium) batteries.
8. Exhausted batteries are to be removed from the toy.
9. The supply terminals are not to be short-circuited.
10. Only batteries of the same or equivalent type as recommended are to be used.
11. Batteries are to be inserted with the correct polarity.
12. Do not dispose of batteries in fire, batteries may explode or leak.
13. Batteries may explode or leak if misused.

FR Important: Conserver ces instructions. NE PAS LES ELIMINER.

Attention:

Lisez attentivement cette notice d'utilisation avant utilisation:

1. Les piles devraient être remplacées par un adulte exclusivement.
2. Les batteries rechargeables ne doivent être rechargées que par les adultes.
3. Les batteries rechargeables doivent être retirées du jouet avant d'être rechargées.
4. Les Piles Non Rechargeables Ne Peuvent Etre Rechargees.
5. Ou Des Piles Neuves Avec Des Piles Usagees. Retirez Les Piles En Cas De Non-Utilisation Prolongee Du Jouet.
6. Ne pas mélanger piles usagées et piles neuves.
7. Ne pas mélanger piles alcalines, standard (zinc carbone) ou rechargeables (cadmium-nickel).
8. Enlever Les Piles Usees Du Jouet.
9. Ne Pas Court-Circuiter Les Poles De Courant.
10. N'utiliser que des piles du type recommandé ou équivalent. Installer les piles en respectant les polarités.
11. Installer les piles en respectant la polarité comme indiqué.
12. Ne jetez pas les piles au feu car elles peuvent exploser ou fuir.
13. Les piles peuvent exploser ou fuir si elles ne sont pas utilisées correctement.

IT IMPORTANTE: Conservare queste istruzioni. NON ELIMINARLE.

Attenzione:

1. Affidare la sostituzione di batterie esclusivamente a personale adulto.
2. Le batterie ricaricabili devono essere ricaricate esclusivamente sotto la supervisione di un adulto.
3. Rimuovere le batterie dal giocattolo prima del caricamento.
4. Le batterie non ricaricabili non possono essere ricaricate.
5. Se non si usa il dispositivo per diverso tempo, togliere le batterie.
6. Non mischiare batterie vecchie con batterie nuove.
7. Non mischiare batterie alcaline, standard (zinc-carbonio) con batterie ricaricabili (nichel-cadmio).
8. Le batterie scariche devono essere tolte dall'unità.
9. Il terminale di alimentazione non deve essere cortocircuitato.
10. Si consiglia l'uso di pile uguali o di tipo equivalente.
11. Le pile vanno inserite osservando la polarità corretta.
12. Non gettare le batterie nel fuoco, poiché possono esplodere o rilasciare sostanze chimiche.
13. Se non sono utilizzate correttamente, le batterie possono esplodere o rilasciare sostanze chimiche.

ES IMPORTANTE: Guardar estas instrucciones. NO TIRAR.

Precaución:

Por favor, lea estas instrucciones detenidamente antes de usar este product:

1. Las pilas deben ser reemplazadas por adultos solamente.
2. Las pilas recargables solo deben cargarse bajo supervisión adulta.
3. Las pilas recargables deben retirarse del juguete antes de cargarlas.
4. No recargar a las pilas no recargables.
5. Si no se va a utilizar el juguete durante mucho tiempo, sacar las pilas.
6. No mezcle pilas nuevas con viejas.
7. No mezcle pilas alcalinas, estándar (carbon zinc) o recargables (nickel cadmium).
8. Sacar las pilas gastadas del juguete.
9. No circuitar el terminal de alimentación.
10. Usar solo las pilas recomendadas o equivalentes.
11. Las pilas deben insertarse respetando la polaridad correcta.
12. No arrojar las pilas al fuego ya que hay peligro de explosión o de fuga de las pilas.
13. Las pilas pueden estallar o tener fugas si no se usan correctamente.

RU ВАЖНО: Сохраните данные инструкции. НЕ ВЫБРАСЫВАТЬ.

Внимание!

Перед использованием внимательно прочтите данные инструкции:

1. Установка и замена батареек должна производиться только взрослыми.
2. Аккумуляторные батареи следует заряжать только под присмотром взрослых.
3. Перед зарядкой аккумуляторные батареи необходимо извлечь из игрушки.
4. Не перезаряжайте батарейки.
5. Если устройство не используется в течение длительного времени, удалите батарейки.
6. Не используйте одновременно старые и новые батарейки.
7. Не используйте одновременно щелочные, стандартные (углеродно-цинковые) или аккумуляторные (никель-кадмиевые) батарейки.
8. Разряженные батарейки необходимо извлекать из игрушки.
9. Замыкание на короткое время питания недопустимо.
10. Рекомендуется использовать только батарейки одного типа и напряжения.
11. При установке батареек необходимо соблюдать полярность.
12. Не подвергайте батарейки воздействию огня, они могут взорваться или протечь.
13. При неправильном использовании батареек они могут взорваться или протечь.

WARNING: Changes or modifications to this unit not expressly approved by the party responsible for compliance could void the user's authority to operate the equipment.

NOTE: This equipment has been tested and found to comply with the limits for a Class B digital device, pursuant to Part 15 of the FCC Rules. These limits are designed to provide reasonable protection against harmful interference in a residential installation. This equipment generates, uses and can radiate radio frequency energy and, if not installed and used in accordance with the instructions, may cause harmful interference to radio communications. However, there is no guarantee that interference will not occur in a particular installation. If this equipment does cause harmful interference to radio or television reception, which can be determined by turning the equipment off and on, the user is encouraged to try to correct the interference by one or more of the following measures:

- Reorient or relocate the receiving antenna.
- Increase the separation between the equipment and receiver.
- Connect the equipment into an outlet on a circuit different from that to which the receiver is connected.
- Consult the dealer or an experienced radio/TV technician for help.

This device complies with Part 15 of FCC Rules. Operation is subject to the following two conditions: (1) This device may not cause harmful interference, and (2) this device must accept any interference received, including interference that may cause undesired operation.

BATTERIES:

- Vehicle requires 5-AA alkaline batteries (not included)
- Controller requires 1-9V alkaline battery (not included)

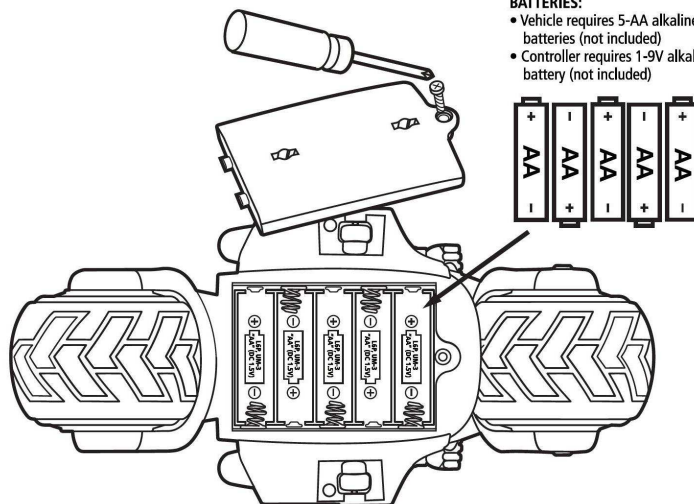

To get the vehicle start working, turn both power switch to "ON" position at the same time.

Trouble Shooting Tips

- If the vehicle is not moving, turn the On/Off switch of the controller and vehicle to "OFF" position.
- Powering down 10 seconds for reset purpose.
- Turn both power switch to "ON" position again to play.

Proof of Purchase

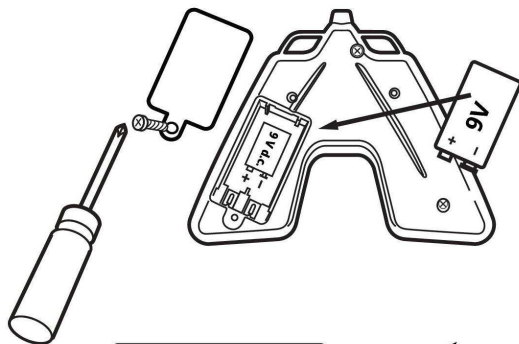

Kawasaki, Ninja® are trademarks licensed by Kawasaki Motors Corp., U.S.A., which does not manufacture or distribute this product. Consumer inquiries should be directed to Kid Galaxy, 150 Dow Street, Manchester, NH 03101 U.S.A.



MADE IN CHINA
©2016 Kid Galaxy, Inc.
All Rights Reserved

Kid Galaxy, Inc.
150 Dow St.
Manchester, NH 03101
USA



1-800-816-1135

Visit our website! www.kidgalaxy.com

Conforms to the safety requirements of ASTM F963 and FCC regulations.

Conforms to the safety requirements of EN71.