

How to operate the SUV & Plane

SUV

1. Turn the switch located at the bottom of the vehicle to the **ON** position.
2. Turn the switch located on the hand set to the **ON** position.
3. Refer to the illustrations to operate the truck.

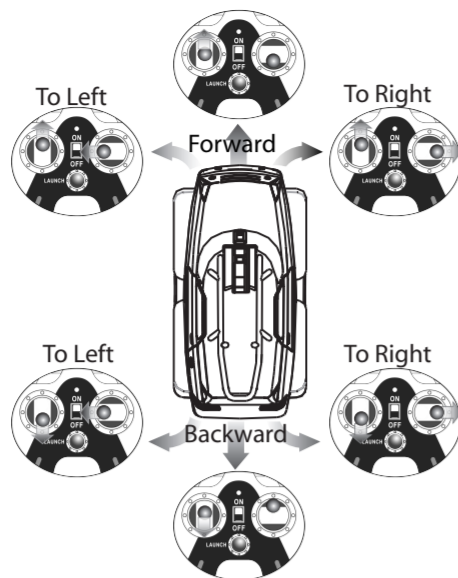

Plane

1. Press the launching rod into the SUV and flip up the hook.
2. Place the hook of the launcher into the square opening located on the bottom of the plane. Lower the tail of the plane onto the roof until it makes contact with the contact plate.
3. Turn the switch located on the hand set to the **ON** position.
4. Drive the SUV 15 to 22 seconds to charge the plane. **The plane cannot be launched if it is not fully charged**
5. Press on the **RED** button located on the hand set to launch the plane.
6. The plane flies better if launching against the wind.

Note:

Be sure to fly the plane in a grassy, wide-open area free of trees, overhead wires and other obstructions. This will ensure soft landings, and will thus help extend the life of your plane. If your plane gets caught in a tree or other object, NEVER climb up to get it yourself. Call an adult for help

-2-

Press the launching rod backward

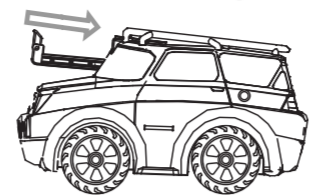

Flip up the hook

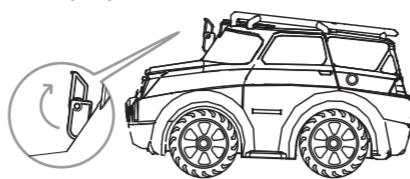

Contact point for charging



Hook of launcher must be placed into the square opening on the bottom of the plane

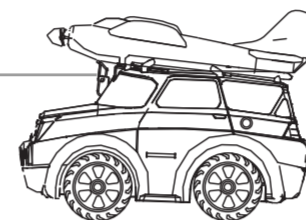
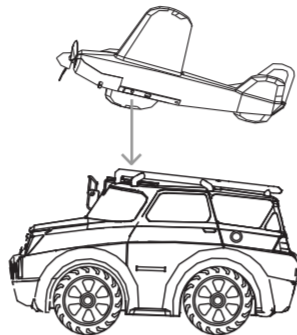

Charging time

0" 15~22sec

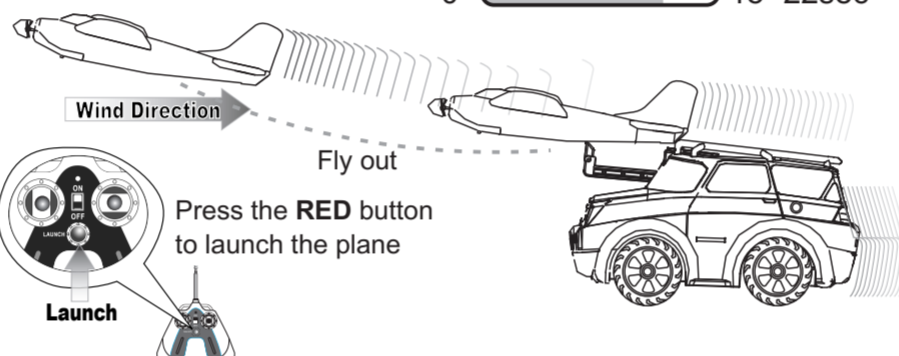

-3-

Flying Tips

The plane performs best & with the longest flying time when it flies in a pattern with big left turning circle. In case the plane does not follow this flying pattern, trim the plane with the label(s) included per instructions.

Notes:

- Apply one label at a time.
 - Using bigger size label for sharper turning.
 - The more labels (or bigger size label) you applied the sharper turning pattern you will get.
- A. If plane does not fly with a left turning pattern, apply label(s) at the tip of the left wing (see illustration #1)
 - B. If plane flies with a sharp left turning pattern, apply label(s) at the tip of the right wing (see illustration #2)
 - C. If plane does not climb up, apply the small size label(s) on both stabilizers horizontally (see illustration #3). The more labels you used the bigger climbing angle you will have. The plane will fly in a wavy (up & down) pattern if too many labels are used.

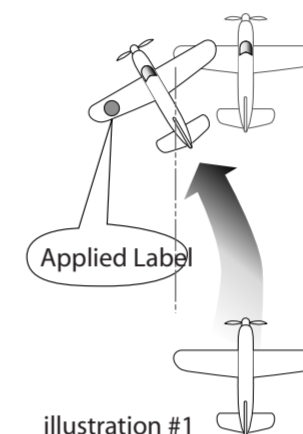

illustration #1

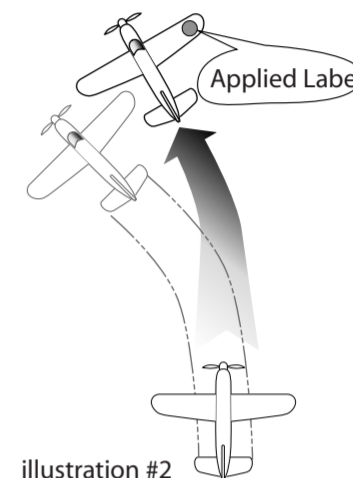

illustration #2

-4-

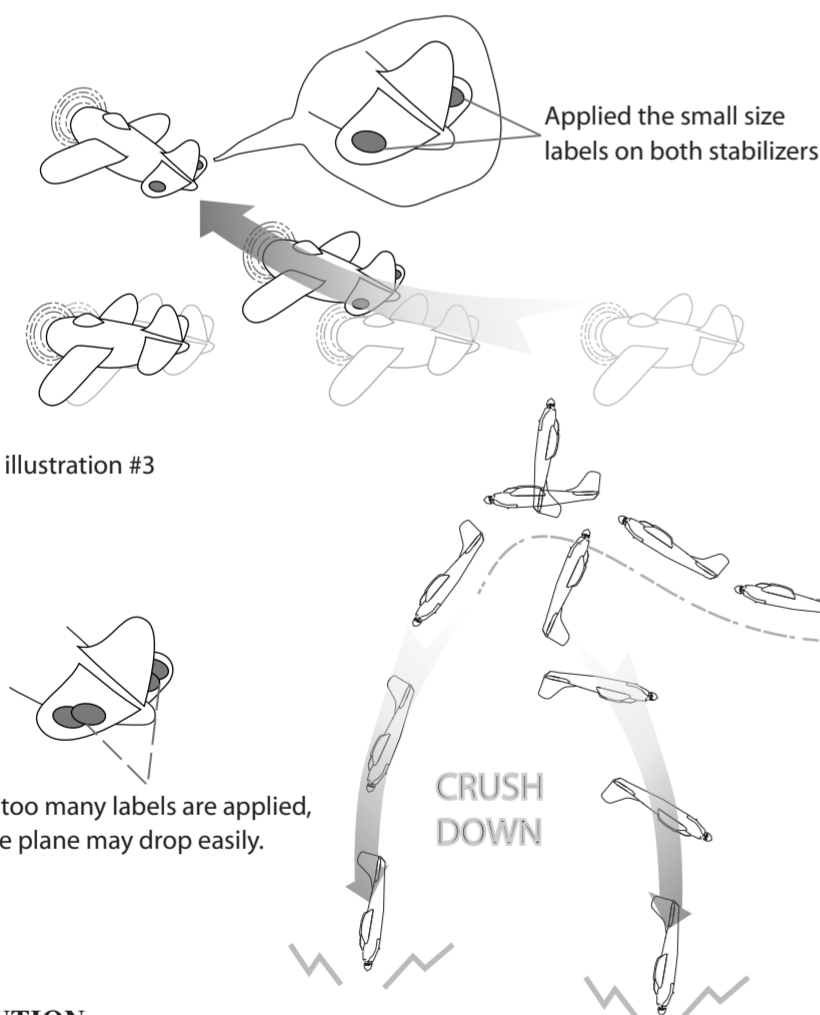

illustration #3

CAUTION:

Plane contains a rechargeable cell. If fluid leaks from plane, avoid contact with eyes and dispose of plane.

ONLY USE CHARGER SUPPLIED WITH DRV.

DO NOT USE ANY OTHER SOURCE TO CHARGE THE PLANE.

-5-

Warning: Changes or modifications to this unit not expressly approved by operator the party responsible for compliance could void the user authority to the equipment.

NOTE: This equipment has been tested and found to comply with the limits for a Class B digital device, pursuant to Part 15 of the FCC Rules. These limits are designed to provide reasonable protection against harmful interference in a residential installation. This equipment generates uses and can radiate radio frequency energy and, if not installed and used in accordance with the instructions, may cause harmful interference to radio communications. However, there is no guarantee that interference will not occur in a particular installation. If this equipment does cause harmful interference to radio or television reception, which can be determined by turning the equipment off and on, the user is encouraged to try to correct the interference by one or more of the following measures:

- Reorient or relocate the receiving antenna.
 - Increase the separation between the equipment and receiver.
 - Connect the equipment into an outlet on a circuit different from that to which the receiver is connected.
 - Consult the dealer or an experienced radio/TV technician for help.
- Helpful Hints**
- Use fresh batteries. The use of weak batteries may cause your vehicle to have slow response times.
 - Do not mix old and new batteries.
 - Do not mix alkaline, standard (Carbon-Zinc) or rechargeable (Ni-Cd) batteries.
 - Your vehicles will not run if the batteries are installed incorrectly, please refer to the illustration located inside the battery compartment.
 - Sometimes the vehicle is driven beyond the radio signal range causing loss of control. Range in your vehicle is approximately 30' to 50'.
 - Running times may vary, alkaline batteries generally last between 25 to 40 minutes.
 - Sometimes loss vehicle control is due to being in an area near interfering sources. CB radios, microwave transmitters, cordless telephones, wireless communications, security systems, high voltage transformer or even certain buildings can cause interference.
 - Avoid driving in damp or wet areas.

Toll Free Kid Galaxy Hot Line:800-816-1135



WARNING:
CHOKING HAZARD - Small parts
Not for children under 8 years.

-6-

SUV & Plane User Manual

Introduction

DRV SUV & Plane is a unique radio controlled vehicle. With a single radio control handset you can control the vehicle and launch the plane. Double the fun. Double the adventure.

Operating Instructions

SUV

1. Unscrew the battery cover on the bottom of the truck with a Philips screw driver.
2. Install 4 AA alkaline batteries with polarities as shown inside the battery compartment.
3. Replace the battery cover and replace the screw.

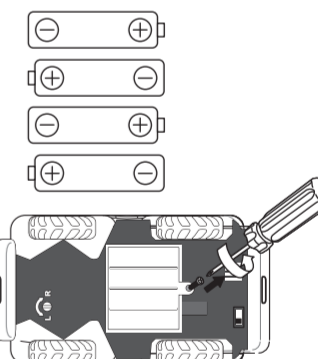

Note: It is strongly NOT recommend using rechargeable battery for SUV as plane CANNOT BE FULLY CHARGED.

Handset

1. Unscrew the battery cover on the bottom of the handset with a Philips screw driver.
2. Install a 9v battery with polarities as shown inside the battery compartment.
3. Replace the battery cover and replace the screw.

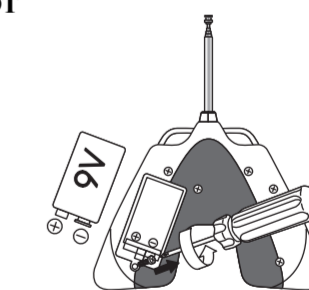

Operation Tips

If your vehicle pulls to the right or left while driving forward, you can adjust the steering with the calibrator.

The calibrator is located on the bottom of the vehicle.

Make slight adjustments until you have the correct forward motion.

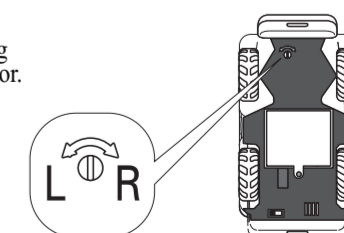

-1-