



www.kinyo.com

Federal Communication Commission Interference Statement

This equipment has been tested and found to comply with the limits for a Class B digital device, pursuant to Part 15 of the FCC Rules. These limits are designed to provide reasonable protection against harmful interference in a residential installation. This equipment generates, uses and can radiate radio frequency energy and, if not installed and used in accordance with the instructions, may cause harmful interference to radio communications. However, there is no guarantee that interference will not occur in a particular installation. If this equipment does cause harmful interference to radio or television reception, which can be determined by turning the equipment off and on, the user is encouraged to try to correct the interference by one of the following measures:

- Reorient or relocate the receiving antenna.
- Increase the separation between the equipment and receiver.
- Connect the equipment into an outlet on a circuit different from that to which the receiver is connected.

• Consult the dealer or an experienced radio/TV technician for help.
FCC Caution: Any changes or modifications not expressly approved by the party responsible for compliance could void the user's authority to operate this equipment.

This device complies with Part 15 of the FCC Rules. Operation is subject to the following two conditions: (1) This device may not cause harmful interference, and (2) this device must accept any interference received, including interference that may cause undesired operation.

IMPORTANT NOTE:

FCC Radiation Exposure Statement:
This equipment complies with FCC radiation exposure limits set forth for an uncontrolled environment. This equipment should be installed and operated with minimum distance 20cm between the radiator & your body.

12564100

ARTDio®

BT-138

**2.0 PORTABLE BLUETOOTH® STEREO SPEAKER
with Built-in Microphone**

User's Guide
Guide d'utilisateur
Guía de Usuario

Bedienungsanleitung
Guida di utente
Guia do usuário

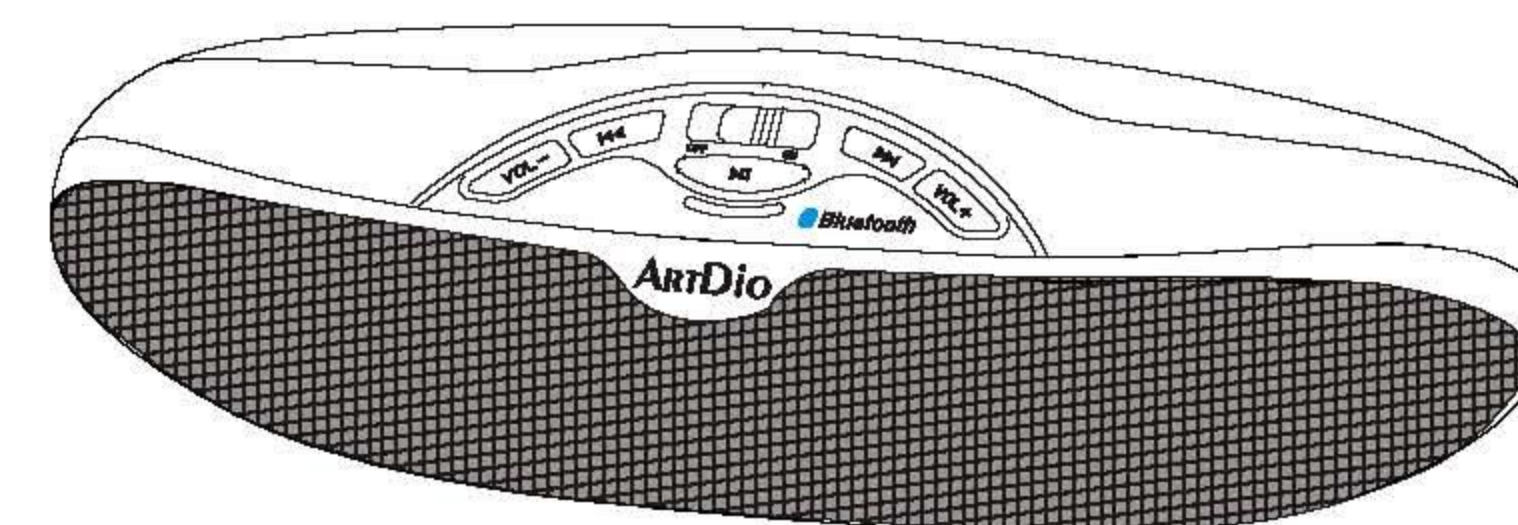

Please read and understand all safety instruction before use.

The Bluetooth® word mark and logos are owned by the Bluetooth SIG, Inc. and any use of such marks by Kinyo Company is under license.

Lire attentivement les instructions avant toute utilisation ou réglage
Le terme et logo "BLUETOOTH" sont la propriété de Bluetooth SIG Inc.
Leurs utilisations est sous licence détenues par Kinyo Co Ltd

IMPORTANT SAFETY INSTRUCTIONS

Please read and understand all safety instructions before use.

- Read these instructions.
- Keep these instructions.
- Heed all warnings.
- Do not use this apparatus near water.
- Clean only with dry cloth.
- Do not block any ventilation openings. Install in accordance with the manufacturer's instructions.
- Do not push objects into apparatus vents or slots because fire or electric shock hazards could result.
- Maintain a minimum distance of at least 6 inches around apparatus for sufficient ventilation
- Ventilation should not be impeded by covering the ventilation openings with items such as newspapers, table cloth, curtains, etc.
- No naked (open) flame sources, such as lighted candles, should be placed on or near apparatus.
- Place apparatus in a stable location so it will not fall causing product damage or bodily harm.
- Do not install near any heat sources such as radiators, heat registers, stoves, or other apparatus (including amplifiers) that produce heat.
- Do not defeat the safety purpose of the polarized plug. A polarized plug has two blades with one wider than the other. The wide blade is provided for your safety. If the provided plug does not fit into your outlet, consult an electrician for replacement of the obsolete outlet.
- Operate the apparatus only from the low level audio line output jack of the computer or of an audio device.
- Protect the power cord from being walked on or pinched particularly at plugs, convenience receptacles, and the point where they exit from the apparatus.
- Only use attachments/ accessories specified by the manufacturer.
- Unplug this apparatus during lightning storms or when unused for long periods of time.
- Refer all servicing to qualified service personnel. Servicing is required when the apparatus has been damaged in any way, such as power-supply cord or plug is damaged liquid has been spilled or objects have fallen into the apparatus, the apparatus has been exposed to rain or moisture, does not operate normally, or has been dropped.
- The apparatus shall be disconnected from the mains by placing the power/standby switch in the standby position and unplugging the power cord of the apparatus from the AC mains receptacle.
- The socket-outlet shall be installed near the equipment and shall be easily accessible.



CAUTION TO REDUCE THE RISK OF ELECTRIC SHOCK, DO NOT REMOVE COVER OR BACK. NO USER-SERVICEABLE PARTS INSIDE. REFER SERVICING TO QUALIFIED SERVICE PERSONNEL.

WARNING TO REDUCE THE RISK OF FIRE OR ELECTRIC SHOCK, DO NOT EXPOSE THIS APPLIANCE TO RAIN OR MOISTURE. CAUTION PILOT LAMP SOLDERED IN PLACE. TO REDUCE THE RISK OF ELECTRIC SHOCK, REFER TO QUALIFIED SERVICE PERSONNEL.

ENVIRONMENTAL PROTECTION RECOMMENDATION
At the end of its working life, this product should not be disposed of with standard household waste, but rather dropped off at a collection point for the disposal of Waste Electrical and Electronic Equipment (WEEE) for recycling.
This is confirmed by the symbol found on the product, user manual or packaging.



The exclamation point within an equilateral triangle is intended to alert the user to the presence of important operating and maintenance (servicing) instructions in the literature accompanying the appliance.



The lightning flash with arrowhead symbol with an equilateral triangle is intended to alert the user to the presence of uninsulated dangerous voltage within the product's enclosure that may be of sufficient magnitude to constitute a risk of electric shock to persons.

Is herewith confirmed to comply with the requirements set out in the Council Directive on the Approximation of the Laws of the Member States relating to Electromagnetic Compatibility (2004/108/EC), Low-voltage Directive (2006/95/EC) and the Amendment Directive (93/68/EEC), the procedures given in European Council Directive 99/5/EC and 2004/108/EC. The equipment was passed. The test was performed according to the following European standards:

ETSI EN 301 489-17 V1.2.1: 2002
ETSI EN 300 328 V1.7.1: 2006
EN60950-1:2006

INTRODUCTION

Artdio's BT-138, is a 2.0 *Bluetooth* Stereo Speaker, supports *Bluetooth* A2DP¹, AVRCP², Headset and Hands-free profiles. The system is capable of streaming music from mobile phones, MP3 players, portable media players, PDA's, computers and other audio devices with *Bluetooth* A2DP enabled. This system operates wirelessly from audio sources up to 33 feet (10 meters) away open space. The built-in microphone, enables to easily answer phone calls hands-free through the system. The system also comes with an auxiliary input that will connect all line in audio sources.

- 1) The playback and its plug-in *Bluetooth* adapter/transmitter/device needs to support A2DP (Advanced Audio Distribution Profile).
- 2) The playback and its plug-in *Bluetooth* adapter/transmitter/device needs support AVRCP (Audio/Video Remote Control Profile).

PRODUCT OVERVIEW

Top

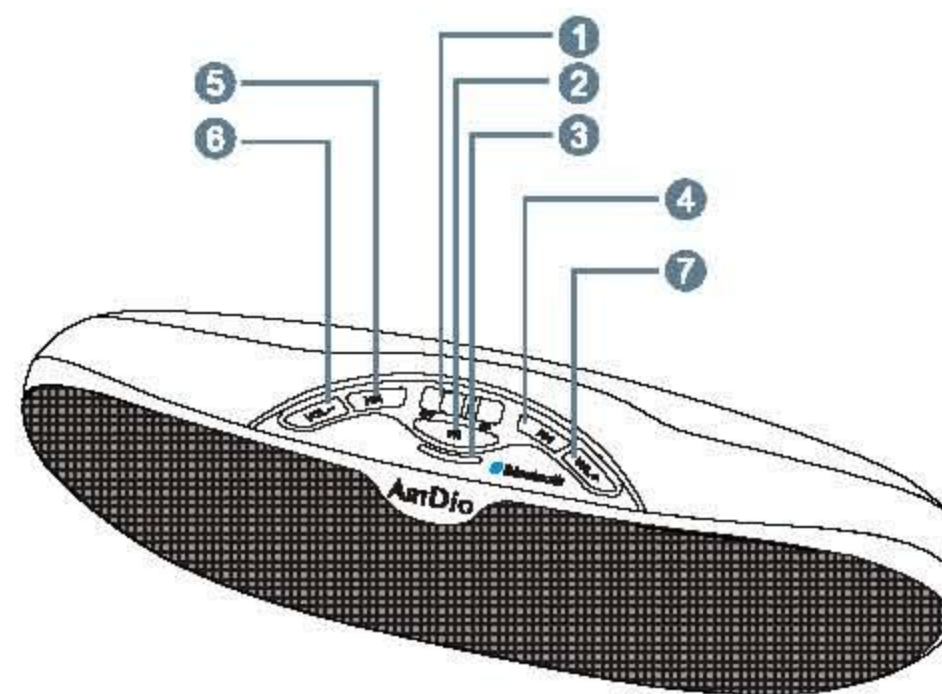

Bottom

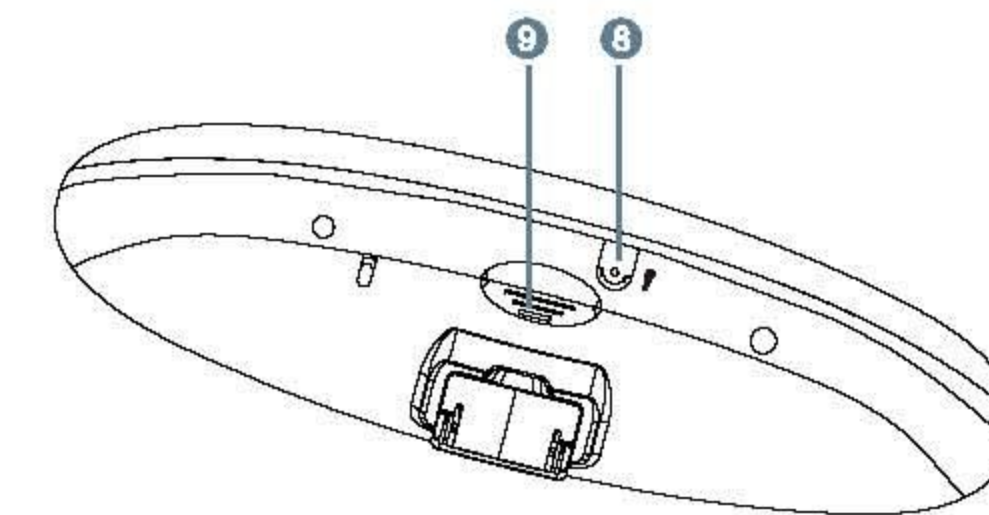

Rear

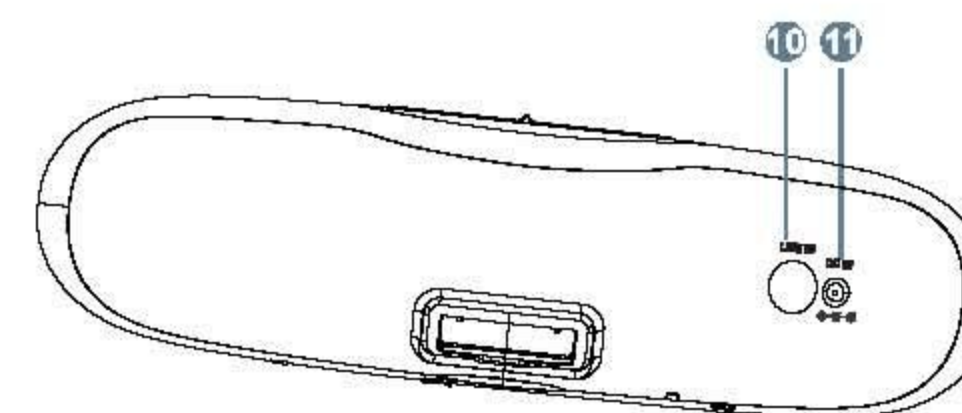

Inside the Compartment

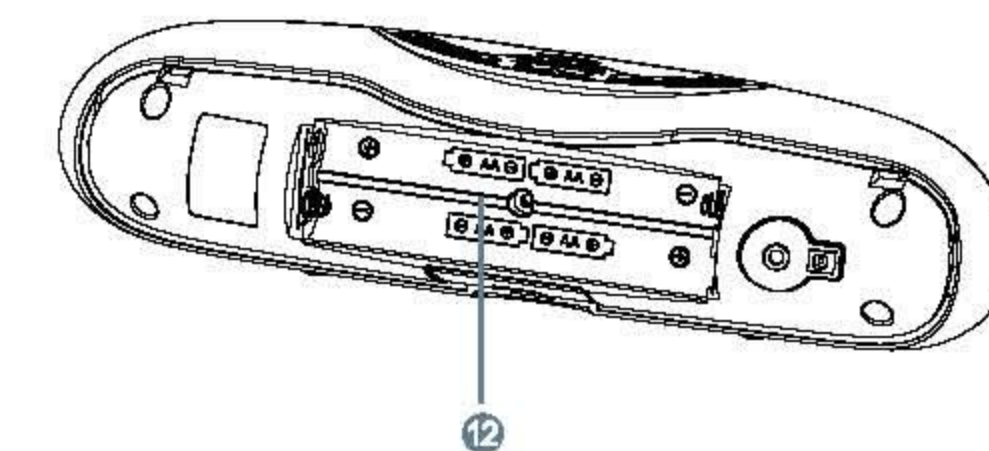

① Power ON/OFF Switch

a) **ON:** Slide switch to ON to turn on the system. This will initiate *Bluetooth* pairing process automatically.

b) **OFF:** Slide switch to OFF to turn off the system

② PAIRING/ PLAY/PAUSE/CALL (only during *Bluetooth* operation)

a) **PAIRING:** Initiate the pairing mode from the speaker to the *Bluetooth* enabled device by pressing and holding the Pairing button "⏏" for three seconds. The *Bluetooth* LED will flash blue light three times. Release the button and the *Bluetooth* LED will then flash blue and red lights alternately to indicate that the speaker is in *Bluetooth* pairing mode. Please see detailed pairing instructions on PAGE 4.

Note: If the pairing process cannot be completed within 90 seconds, the blue and red *Bluetooth* LED will stop flashing and the *Bluetooth* pairing process will automatically terminate. Please repeat the pairing instructions to pair up the *Bluetooth* speaker with the *Bluetooth* enabled device.

b) **PLAY/PAUSE:** Press "⏏" button to play the selection, press again to pause.

c) **ANSWERING/ ENDING CALL:** To answer a call on your *Bluetooth* device (when connected to the *Bluetooth* speaker) press "⏏" button to answer the call. Press the button again to end the call.

③ BLUETOOTH PAIRING LED Indicator/Low Battery Indicator:

a) **BLUETOOTH PAIRING LED Indicator:**

The *Bluetooth* LED will flash blue and red light alternately to indicate that the *Bluetooth* speaker enters pairing mode. When the *Bluetooth* device has successfully paired and connected with the *Bluetooth* speaker. The *Bluetooth* LED will flash blue light constantly. If the *Bluetooth* connection is disconnected, the blue LED will flash three times to indicate the *Bluetooth* signal is disconnected.

b) **Low Battery Indicator:** Red LED Indicator will flash when battery is low. (only during *Bluetooth* operation)

④ **⏪: PREVIOUS:** Press to play the previous selection. (only during *Bluetooth* operation)

⑤ **⏩: NEXT:** Press to play the next selection. (only during *Bluetooth* operation)

⑥ **VOL-:** Press to decrease the volume.

⑦ **VOL+:** Press to increase the volume.

⑧ **📞:** The Built-in Microphone is located on the bottom of the system.

Note: Make sure your *Bluetooth* enabled device is connected with the *Bluetooth* speaker. When the phone rings on your *Bluetooth* enabled device press the pairing "⏏" button to answer the call. You will be able to talk hands-free through the microphone. Press the pairing "⏏" button again to end the call.

⑨ **Open here to remove compartment cover.**

⑩ **LINE IN:** To connect to alternate audio source, insert one end of the 3.5mm stereo input cable to LINE IN jack. Insert the other end to an audio source.

⑪ **DC IN:** Plug AC adapter (included) into a wall outlet. Connect the other end to the "DC IN" jack.

⑫ **Battery Compartment.**

POWER SOURCE

Use ONE of the following options to power the speaker:

AC Power (Wall Outlet)

1. Plug AC adapter into a wall outlet. Connect other end to the "DC IN" jack on back of the system.

DC Power (Batteries)

1. Install 4 AAA batteries (not included) into the battery compartment on the back of the system. Make sure the batteries are installed as illustrated.
2. When the battery power is low, the *Bluetooth* LED will flash red light indicating it is time to replace batteries. (only during *Bluetooth* operation). Do not mix different or new and used batteries.

PAIRING WITH BLUETOOTH ENABLED DEVICES

You need to pair the system with your *Bluetooth* device before using.

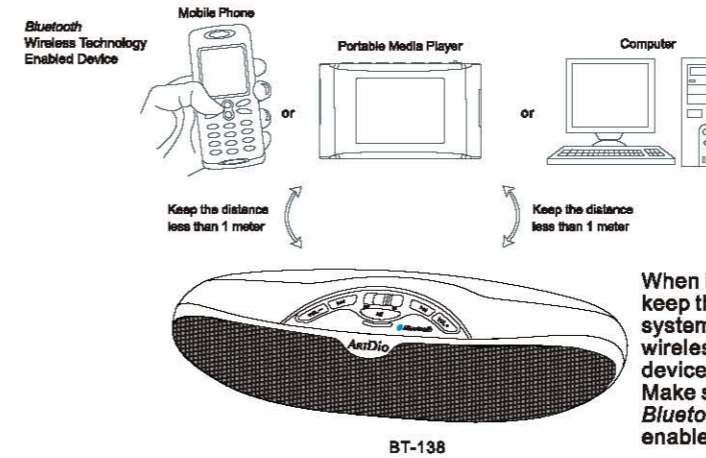

Pairing is the process of associating your speaker with *Bluetooth* enabled devices. Pairing establishes a permanent security link between all devices using *Bluetooth* wireless technology. You will be prompted to enter a PIN (personal identification number) to establish the initial pairing. After the pairing is successful, you will not have to re-enter it again. The device remembers the PIN and will automatically connect to the speaker.

The following pairing instructions describe the pairing process between the speaker and a typical *Bluetooth* audio source. The pairing process may be different for your *Bluetooth* enabled devices. If you have problems pairing, please refer to the user's guide of your specific device for detailed pairing instructions.

PAIRING WITH ANY BLUETOOTH A2DP ENABLED DEVICES

1. Turn on the *Bluetooth* speaker by sliding POWER ON/OFF switch to "ON". This will automatically initiate the *Bluetooth* pairing process.
2. The *Bluetooth* pairing LED will flash blue light three times then flashes blue and red light alternately. This indicates that the *Bluetooth* speaker is in the pairing mode.
3. Turn on the *Bluetooth* settings on your *Bluetooth* enabled device. Then perform a search for *Bluetooth* devices in range.
4. Your *Bluetooth* enabled device will display a new device named "ARTDIO" on the *Bluetooth* Device List.
5. Select "ARTDIO" from the *Bluetooth* Device List.
6. You are prompted to enter a PIN. Enter the default PIN of "0000."
7. When the *Bluetooth* LED flashes blue light constantly, it indicates that the pairing process has been completed successfully. Your computer and the *Bluetooth* speaker are now connected through *Bluetooth* wireless technology.
8. The screen on your *Bluetooth* enabled device should display a *Bluetooth* (Ⓜ) or audio icon (🔊 / 🎧) to indicate *Bluetooth* connection.

NOTE: If the pairing process cannot be completed within 90 seconds, the blue and red *Bluetooth* LED stops flashing and the *Bluetooth* pairing process will automatically terminate. Please repeat the pairing instructions to pair up the speaker with the *Bluetooth* enabled device.

9. Select music on your *Bluetooth* device to play wirelessly through your BT-138 speaker system. Refer to the user's guide of your *Bluetooth* enabled device for more detailed instructions.

PAIRING WITH BLUETOOTH ENABLED COMPUTER

1. Start the *Bluetooth* application on your computer, then perform a search for *Bluetooth* enabled devices in range.
2. Turn on the *Bluetooth* speaker by sliding POWER ON/OFF switch to "ON". This will automatically initiate the *Bluetooth* pairing process.
3. The *Bluetooth* pairing LED will flash blue light three times then flashes blue and red light alternately. This indicates that the *Bluetooth* speaker is in the pairing mode.
4. Your computer should now display a new device named "ARTDIO" on the *Bluetooth* Device List.
5. Select "ARTDIO" from the *Bluetooth* Device List.
6. You are prompted to enter a PIN, enter the default PIN of "0000."
7. When the *Bluetooth* LED flashes blue light constantly, it indicates the pairing process has been completed successfully. Your computer and the *Bluetooth* speaker are now connected through *Bluetooth* wireless technology.

NOTE: If the pairing process cannot be completed within 90 seconds, the blue and red *Bluetooth* LED stops flashing and the *Bluetooth* pairing process will automatically terminate. Please repeat the pairing instructions to pair up the speaker with the *Bluetooth* enabled device.

8. Select music on your computer to play wirelessly through your BT-138 speaker system. Refer to the user's guide of your *Bluetooth* application for more detailed instructions.

PAIRING WITH A COMPUTER WITH A BLUETOOTH USB ADAPTER

1. For all computers that are not *Bluetooth* enabled, plug in the *Bluetooth* USB Adapter into a USB port on your computer. Install the software if required (refer to the user's guide for detailed instructions for software installation)
2. Start the *Bluetooth* application on your computer. Perform a search for *Bluetooth* devices in range.
3. Turn on the *Bluetooth* speaker by sliding POWER ON/OFF switch to "ON". This will automatically initiate the *Bluetooth* pairing process.
4. The *Bluetooth* pairing LED will flash blue light three times then flashes blue and red light alternately. This indicates that the *Bluetooth* speaker is in the pairing mode.
5. Your computer should now display a new device named "ARTDIO" on the *Bluetooth* Device List.
6. Select "ARTDIO" from the *Bluetooth* Device List.
7. You are prompted to enter a PIN. Enter the default PIN of "0000."
8. When the *Bluetooth* Pairing LED flashes blue light constantly, it indicates that the pairing process has been completed successfully. Your computer and the *Bluetooth* speaker are now connected through *Bluetooth* wireless technology.

NOTE: If the pairing process cannot be completed within 90 seconds, the blue and red *Bluetooth* LED stops flashing and the *Bluetooth* pairing process will automatically terminate. Please repeat the pairing instructions to pair up the speaker with the *Bluetooth* enabled device.

9. Select music on your computer to play wirelessly through your BT-138 speaker system. Refer to the user's guide of your *Bluetooth* USB adapter for more detailed instructions.

USING YOUR BLUETOOTH SPEAKER

Using Your *Bluetooth* Speaker for Wireless Music

1. Select music from your *Bluetooth* enabled device and play wirelessly through the speaker.
2. Press VOL+ or VOL- to adjust the volume.
3. Press ◀ or ▶ to play previous or next selection.

Using Your *Bluetooth* Speaker for Hands-free Call

1. If the phone rings from your *Bluetooth* enabled device, press the "▶" button to answer the phone. Enjoy your conversation hands-free through built-in microphone.
2. End the call by pressing the "▶" button again.
3. Music will resume after the call.

CONNECTING TO OTHER AUDIO SOURCES

The speaker system has an auxiliary input that can connect to alternate audio sources such as iPod, MP3 players, CD players, laptop, computers etc.

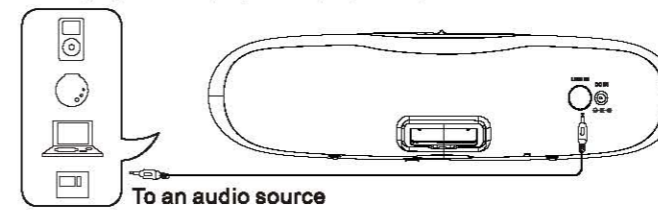

1. Be sure to disconnect all *Bluetooth* wireless connections. Press and hold the Pairing button "▶" for 3 seconds. The Pairing LED will flash blue light three times to indicate the *Bluetooth* wireless is disconnected.
2. The *Bluetooth* wireless connection will be terminated when the system is connected to other audio sources.
3. Insert one end of the 3.5mm stereo input cable into the "LINE IN" jack on the back of the system and insert the other end of the cable to your audio source. (iPod, PSP™, MP3 player, portable CD players, computer, etc.)
4. Turn on the audio source and play music.
5. Press VOL+ or VOL- to adjust the volume.

SPECIFICATIONS

- 4 Watts Total RMS
- Pre-Amplified & Magnetically Shielded
- 2 Watts per Channel
- 2 x 1 1/2" Full Range NdFeB Drivers
- Frequency Response: 120Hz~20kHz
- Signal Input: *Bluetooth*, 3.5mm Stereo
- Built-in *Bluetooth* Receiver
- Digital Signal Processing
- Built-in Microphone
- Amplified By Class D IC
- Functions: Power, Volume Controls, Pairing/Play/Pause/Talk, Previous, Next
- LED Indicators: Power Indicator, *Bluetooth*/ Low Battery Indicator
- Power Source: AC / DC Adapter (DC 6V 1A), Battery (4 x AA 1.5V)
- Unit Dimensions: W238mm x H60mm x D70mm

Specifications for *Bluetooth*:

- *Bluetooth* v1.2 Compliant
- *Bluetooth* Radio class 2
- 2.4GHz-2.4835GHz ISM Bandwidth
- Supports *Bluetooth* A2DP, AVRCP, Headset and Hands-free Profiles
- UP to 33 Feet Operating Range (open space)
- Security Supports Pairing, Encryption Authentication
- No software installation is needed

ACCESSORIES



AA Batteries 1.5V x 4

AC/DC Adapter x 1

3.5mm Stereo Input Cable x 1

User's Guide x 1